



(19) **United States**  
(12) **Patent Application Publication**  
**Fennell**

(10) **Pub. No.: US 2016/0317071 A1**  
(43) **Pub. Date: Nov. 3, 2016**

(54) **METHOD AND APPARATUS FOR PROVIDING DYNAMIC MULTI-STAGE SIGNAL AMPLIFICATION IN A MEDICAL DEVICE**

continuation of application No. 12/849,004, filed on Aug. 2, 2010, now Pat. No. 7,948,369, which is a continuation of application No. 12/102,836, filed on Apr. 14, 2008, now Pat. No. 7,768,387.

(71) Applicant: **Abbott Diabetes Care Inc.**, Alameda, CA (US)

(60) Provisional application No. 60/911,866, filed on Apr. 14, 2007.

(72) Inventor: **Martin J. Fennell**, Concord, CA (US)

**Publication Classification**

(73) Assignee: **Abbott Diabetes Care Inc.**, Alameda, CA (US)

(51) **Int. Cl.**  
*A61B 5/145* (2006.01)  
*A61B 5/1486* (2006.01)  
*A61M 5/172* (2006.01)  
*A61B 5/00* (2006.01)

(21) Appl. No.: **15/209,741**

(22) Filed: **Jul. 13, 2016**

(52) **U.S. Cl.**  
CPC ..... *A61B 5/14532* (2013.01); *A61B 5/7225* (2013.01); *A61B 5/0004* (2013.01); *A61B 5/002* (2013.01); *A61B 5/14546* (2013.01); *A61B 5/14865* (2013.01); *A61B 5/7246* (2013.01); *A61B 5/7475* (2013.01); *A61M 5/1723* (2013.01); *A61B 2560/0209* (2013.01); *A61B 2560/0252* (2013.01); *A61B 2560/045* (2013.01)

**Related U.S. Application Data**

(63) Continuation of application No. 14/596,759, filed on Jan. 14, 2015, now Pat. No. 9,402,584, which is a continuation of application No. 14/188,659, filed on Feb. 24, 2014, now Pat. No. 8,937,540, which is a continuation of application No. 13/867,948, filed on Apr. 22, 2013, now Pat. No. 8,698,615, which is a continuation of application No. 13/437,894, filed on Apr. 2, 2012, now Pat. No. 8,427,298, which is a continuation of application No. 13/114,029, filed on May 23, 2011, now Pat. No. 8,149,103, which is a

(57) **ABSTRACT**

Methods and apparatus for providing multi-stage signal amplification in a medical telemetry system are provided.

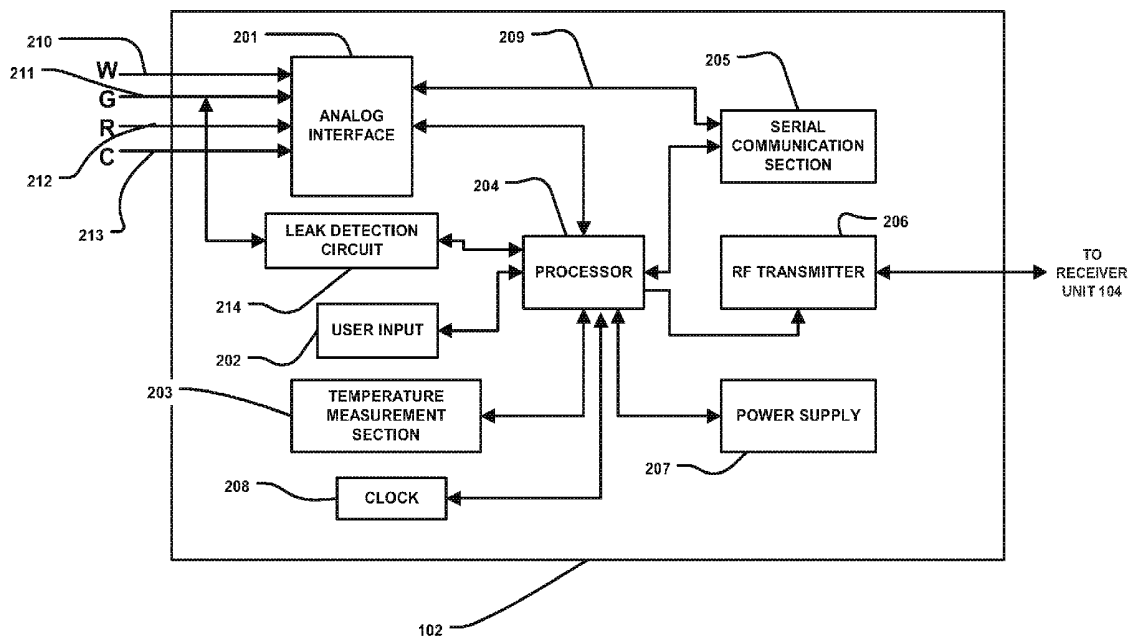

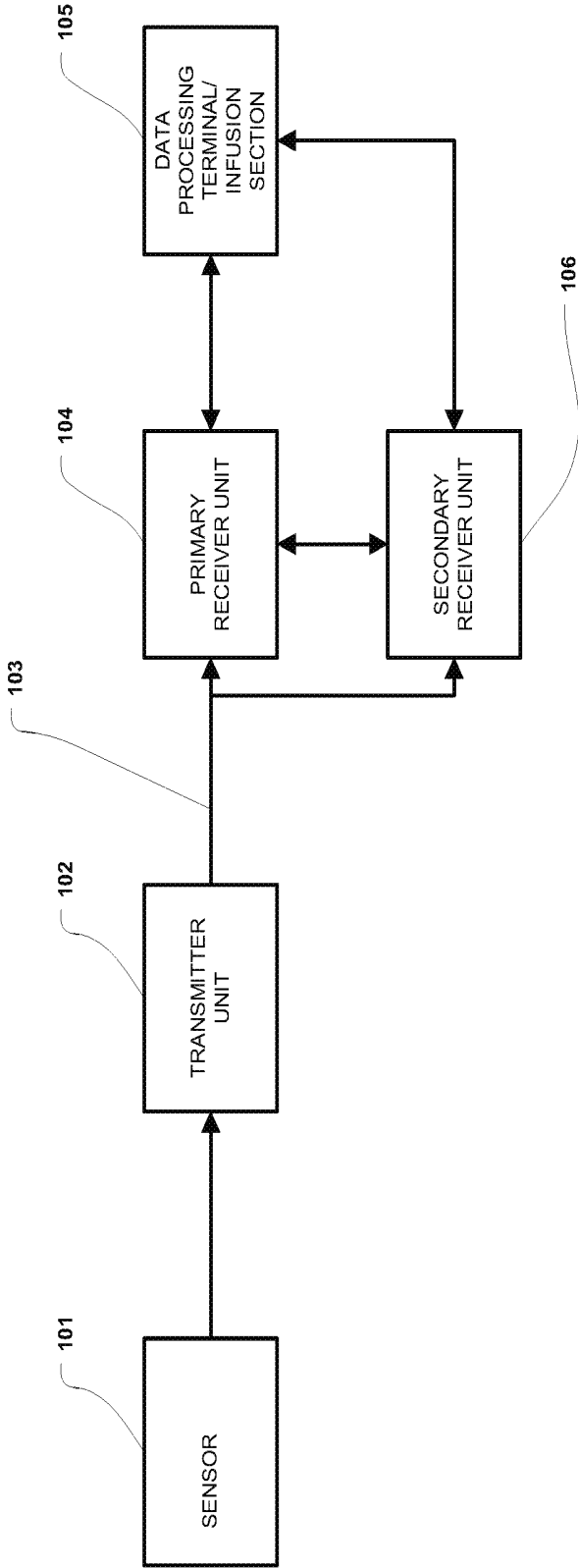

100

FIGURE 1

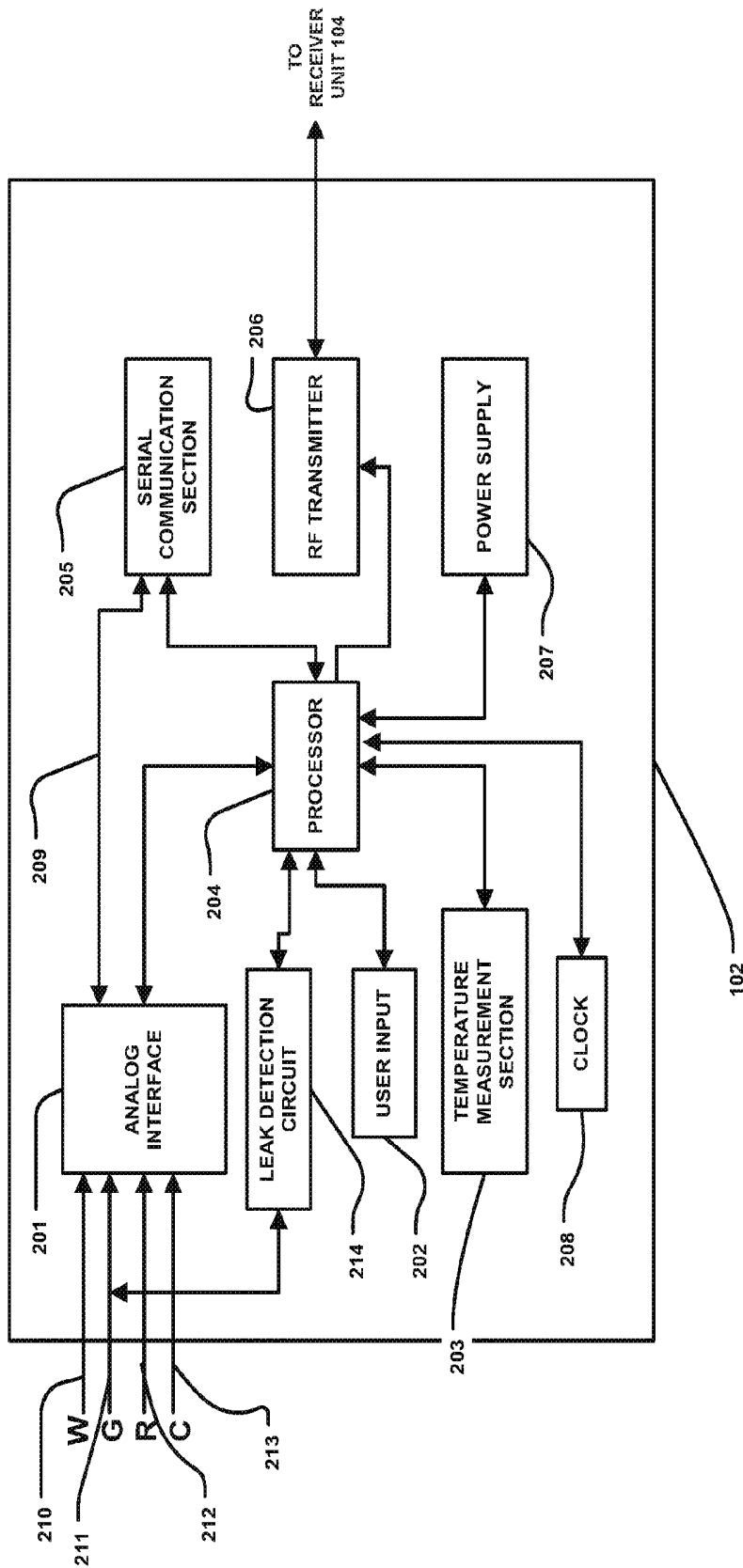

FIGURE 2

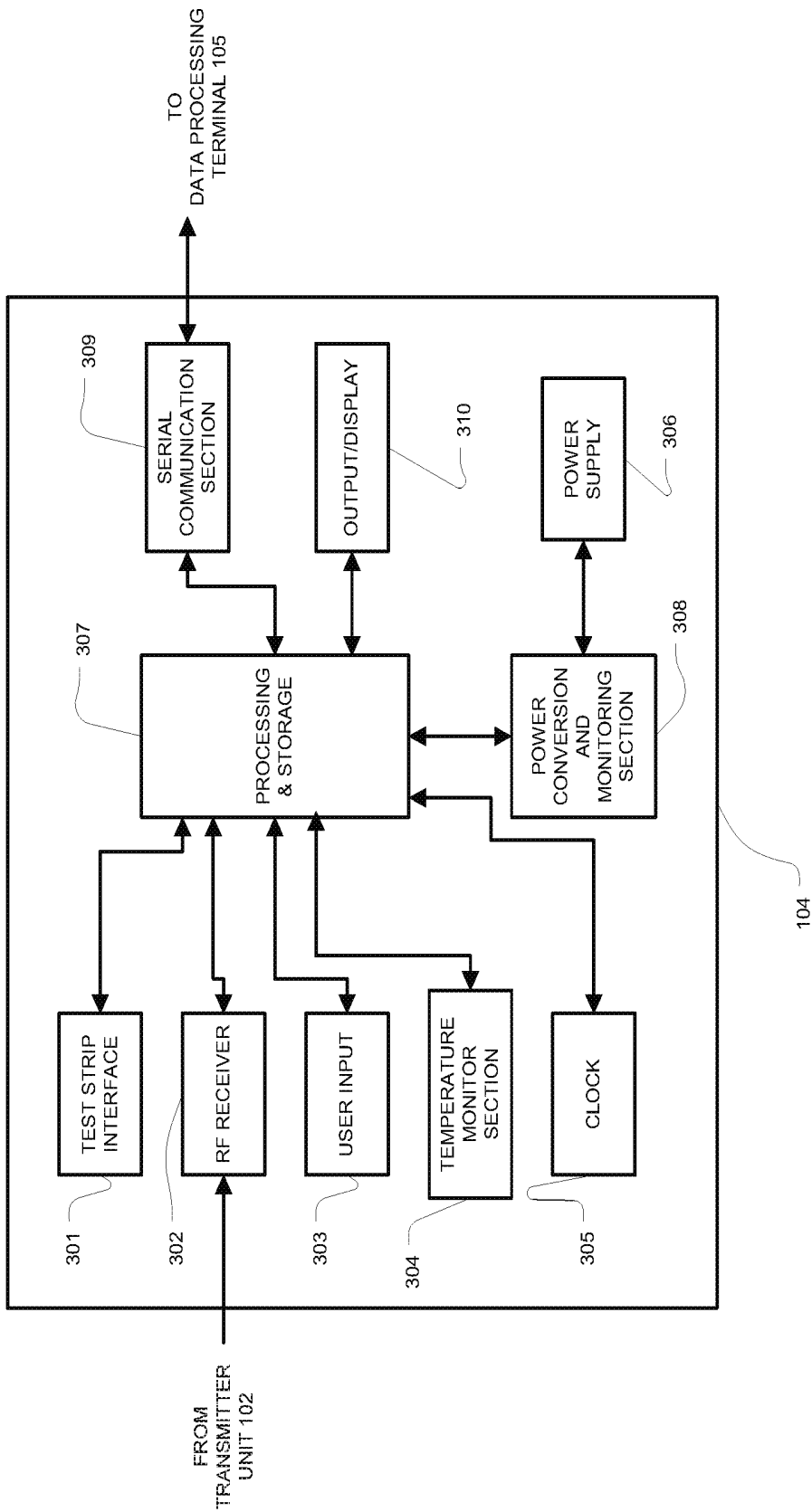

FIGURE 3

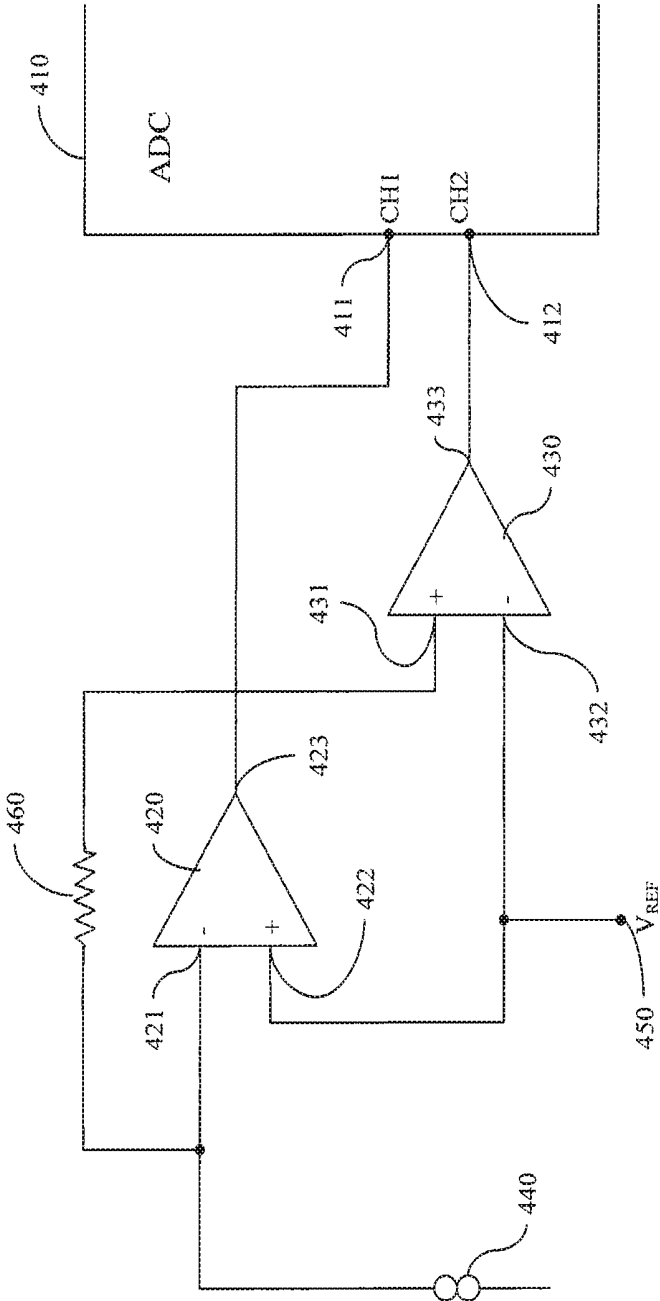

FIGURE 4

**METHOD AND APPARATUS FOR  
PROVIDING DYNAMIC MULTI-STAGE  
SIGNAL AMPLIFICATION IN A MEDICAL  
DEVICE**

RELATED APPLICATIONS

[0001] The present application is a continuation of U.S. patent application Ser. No. 14/596,759 filed Jan. 14, 2015, which is a continuation of U.S. patent application Ser. No. 14/188,659 filed Feb. 24, 2014, now U.S. Pat. No. 8,937,540, which is a continuation of U.S. patent application Ser. No. 13/867,948 filed Apr. 22, 2013, now U.S. Pat. No. 8,698,615, which is a continuation of U.S. patent application Ser. No. 13/437,894 filed Apr. 2, 2012, now U.S. Pat. No. 8,427,298, which is a continuation of U.S. patent application Ser. No. 13/114,029 filed May 23, 2011, now U.S. Pat. No. 8,149,103, which is a continuation of U.S. patent application Ser. No. 12/849,004 filed Aug. 2, 2010, now U.S. Pat. No. 7,948,369, which is a continuation of U.S. patent application Ser. No. 12/102,836 filed Apr. 14, 2008, now U.S. Pat. No. 7,768,387, which claims priority under §35 U.S.C. 119(e) to U.S. Provisional Application No. 60/911,866 filed Apr. 14, 2007, entitled "Method and Apparatus for Providing Dynamic Multi-Stage Signal Amplification in a Medical Device", the disclosures of each of which are incorporated herein by reference for all purposes.

BACKGROUND

[0002] Analyte (e.g., glucose) monitoring systems including continuous and discrete monitoring systems generally include a small, lightweight battery powered and microprocessor controlled system which is configured to detect signals proportional to the corresponding measured glucose levels using an electrometer, and RF signals to transmit the collected data. One aspect of certain analyte monitoring systems include a transcutaneous or subcutaneous analyte sensor configuration which is, for example, partially mounted on the skin of a subject whose analyte level is to be monitored. The sensor cell may use a two or three-electrode (work, reference and counter electrodes) configuration driven by a controlled potential (potentiostat) analog circuit connected through a contact system.

[0003] The analyte sensor may be configured so that a portion thereof is placed under the skin of the patient so as to detect the analyte levels of the patient, and another portion of segment of the analyte sensor that is in communication with the transmitter unit. The transmitter unit is configured to transmit the analyte levels detected by the sensor over a wireless communication link such as an RF (radio frequency) communication link to a receiver/monitor unit. The receiver/monitor unit performs data analysis, among others on the received analyte levels to generate information pertaining to the monitored analyte levels. To provide flexibility in analyte sensor manufacturing and/or design, among others, tolerance of a larger range of the analyte sensor sensitivities for processing by the transmitter unit is desirable.

[0004] In view of the foregoing, it would be desirable to have a method and apparatus for providing a dynamic multi-stage amplification of signals for use in medical telemetry systems such as, for example, analyte monitoring systems.

SUMMARY OF THE INVENTION

[0005] In one embodiment, an apparatus including a first amplifier having at least one input terminal and an output terminal, the at least one input terminal coupled to a signal source, the output terminal configured to provide a first output signal, a second amplifier having at least one input terminal and an output terminal, the at least one input terminal coupled to the output terminal of the first amplifier, the output terminal of the second amplifier configured to provide a second output signal, a processor operatively coupled to receive the first output signal and the second output signal, where the first output signal is a predetermined ratio of the second output signal, and further, where the first output signal and the second output signal are associated with a monitored analyte level of a user is disclosed.

[0006] These and other objects, features and advantages of the present invention will become more fully apparent from the following detailed description of the embodiments, the appended claims and the accompanying drawings.

BRIEF DESCRIPTION OF THE DRAWINGS

[0007] FIG. 1 illustrates a block diagram of a data monitoring and management system for practicing one or more embodiments of the present invention;

[0008] FIG. 2 is a block diagram of the transmitter unit of the data monitoring and management system shown in FIG. 1 in accordance with one embodiment of the present invention;

[0009] FIG. 3 is a block diagram of the receiver/monitor unit of the data monitoring and management system shown in FIG. 1 in accordance with one embodiment of the present invention; and

[0010] FIG. 4 is a schematic of the dynamic multi-stage signal amplification in the transmitter unit of the data monitoring and management system shown in FIG. 1 in accordance with one embodiment of the present invention.

DETAILED DESCRIPTION

[0011] As described in further detail below, in accordance with the various embodiments of the present invention, there is provided a method and apparatus for providing dynamic multi-stage signal amplification for use in a medical telemetry system. In particular, within the scope of the present invention, there are provided method and apparatus for a multi-stage signal amplifier configuration in the analog interface of the data transmitter unit in the data processing and management system.

[0012] FIG. 1 illustrates a data monitoring and management system such as, for example, analyte (e.g., glucose) monitoring system 100 in accordance with one embodiment of the present invention. The subject invention is further described primarily with respect to a glucose monitoring system for convenience and such description is in no way intended to limit the scope of the invention. It is to be understood that the analyte monitoring system may be configured to monitor a variety of analytes, e.g., lactate, and the like.

[0013] Analytes that may be monitored include, for example, acetyl choline, amylase, bilirubin, cholesterol, chorionic gonadotropin, creatine kinase (e.g., CK-MB), creatine, DNA, fructosamine, glucose, glutamine, growth hormones, hormones, ketones, lactate, peroxide, prostate-spe-

cific antigen, prothrombin, RNA, thyroid stimulating hormone, and troponin. The concentration of drugs, such as, for example, antibiotics (e.g., gentamicin, vancomycin, and the like), digitoxin, digoxin, drugs of abuse, theophylline, and warfarin, may also be monitored.

[0014] The analyte monitoring system 100 includes a sensor 101, a transmitter unit 102 coupled to the sensor 101, and a primary receiver unit 104 which is configured to communicate with the transmitter unit 102 via a communication link 103. The primary receiver unit 104 may be further configured to transmit data to a data processing terminal 105 for evaluating the data received by the primary receiver unit 104. Moreover, the data processing terminal in one embodiment may be configured to receive data directly from the transmitter unit 102 via a communication link which may optionally be configured for bi-directional communication.

[0015] Also shown in FIG. 1 is a secondary receiver unit 106 which is operatively coupled to the communication link and configured to receive data transmitted from the transmitter unit 102. Moreover, as shown in the Figure, the secondary receiver unit 106 is configured to communicate with the primary receiver unit 104 as well as the data processing terminal 105. Indeed, the secondary receiver unit 106 may be configured for bi-directional wireless communication with each of the primary receiver unit 104 and the data processing terminal 105. As discussed in further detail below, in one embodiment of the present invention, the secondary receiver unit 106 may be configured to include a limited number of functions and features as compared with the primary receiver unit 104. As such, the secondary receiver unit 106 may be configured substantially in a smaller compact housing or embodied in a device such as a wrist watch, for example. Alternatively, the secondary receiver unit 106 may be configured with the same or substantially similar functionality as the primary receiver unit 104, and may be configured to be used in conjunction with a docking cradle unit for placement by bedside, for night time monitoring, and/or bi-directional communication device.

[0016] Only one sensor 101, transmitter unit 102, communication link 103, and data processing terminal 105 are shown in the embodiment of the analyte monitoring system 100 illustrated in FIG. 1. However, it will be appreciated by one of ordinary skill in the art that the analyte monitoring system 100 may include one or more sensor 101, transmitter unit 102, communication link 103, and data processing terminal 105. Moreover, within the scope of the present invention, the analyte monitoring system 100 may be a continuous monitoring system, or semi-continuous, or a discrete monitoring system. In a multi-component environment, each device is configured to be uniquely identified by each of the other devices in the system so that communication conflict is readily resolved between the various components within the analyte monitoring system 100.

[0017] In one embodiment of the present invention, the sensor 101 is physically positioned in or on the body of a user whose analyte level is being monitored. The sensor 101 may be configured to continuously sample the analyte level of the user and convert the sampled analyte level into a corresponding data signal for transmission by the transmitter unit 102. In one embodiment, the transmitter unit 102 is coupled to the sensor 101 so that both devices are positioned on the user's body, with at least a portion of the analyte

sensor 101 positioned transcutaneously under the skin layer of the user. The transmitter unit 102 performs data processing such as filtering and encoding on data signals, each of which corresponds to a sampled analyte level of the user, for transmission to the primary receiver unit 104 via the communication link 103.

[0018] In one embodiment, the analyte monitoring system 100 is configured as a one-way RF communication path from the transmitter unit 102 to the primary receiver unit 104. In such embodiment, the transmitter unit 102 transmits the sampled data signals received from the sensor 101 without acknowledgement from the primary receiver unit 104 that the transmitted sampled data signals have been received. For example, the transmitter unit 102 may be configured to transmit the encoded sampled data signals at a fixed rate (e.g., at one minute intervals) after the completion of the initial power on procedure. Likewise, the primary receiver unit 104 may be configured to detect such transmitted encoded sampled data signals at predetermined time intervals. Alternatively, the analyte monitoring system 100 may be configured with a bi-directional RF (or otherwise) communication between the transmitter unit 102 and the primary receiver unit 104.

[0019] Additionally, in one aspect, the primary receiver unit 104 may include two sections. The first section is an analog interface section that is configured to communicate with the transmitter unit 102 via the communication link 103. In one embodiment, the analog interface section may include an RF receiver and an antenna for receiving and amplifying the data signals from the transmitter unit 102, which are thereafter, demodulated with a local oscillator and filtered through a band-pass filter. The second section of the primary receiver unit 104 is a data processing section which is configured to process the data signals received from the transmitter unit 102 such as by performing data decoding, error detection and correction, data clock generation, and data bit recovery.

[0020] In operation, upon completing the power-on procedure, the primary receiver unit 104 is configured to detect the presence of the transmitter unit 102 within its range based on, for example, the strength of the detected data signals received from the transmitter unit 102 or a predetermined transmitter identification information. Upon successful synchronization with the corresponding transmitter unit 102, the primary receiver unit 104 is configured to begin receiving from the transmitter unit 102 data signals corresponding to the user's detected analyte level. More specifically, the primary receiver unit 104 in one embodiment is configured to perform synchronized time hopping with the corresponding synchronized transmitter unit 102 via the communication link 103 to obtain the user's detected analyte level.

[0021] Referring again to FIG. 1, the data processing terminal 105 may include a personal computer, a portable computer such as a laptop or a handheld device (e.g., personal digital assistants (PDAs)), and the like, each of which may be configured for data communication with the receiver via a wired or a wireless connection. Additionally, the data processing terminal 105 may further be connected to a data network (not shown) for storing, retrieving and updating data corresponding to the detected analyte level of the user.

[0022] Within the scope of the present invention, the data processing terminal 105 may include an infusion device

such as an insulin infusion pump or the like, which may be configured to administer insulin to patients, and which may be configured to communicate with the receiver unit 104 for receiving, among others, the measured analyte level. Alternatively, the receiver unit 104 may be configured to integrate an infusion device therein so that the receiver unit 104 is configured to administer insulin therapy to patients, for example, for administering and modifying basal profiles, as well as for determining appropriate boluses for administration based on, among others, the detected analyte levels received from the transmitter unit 102.

[0023] Additionally, the transmitter unit 102, the primary receiver unit 104 and the data processing terminal 105 may each be configured for bi-directional wireless communication such that each of the transmitter unit 102, the primary receiver unit 104 and the data processing terminal 105 may be configured to communicate (that is, transmit data to and receive data from) with each other via the wireless communication link. More specifically, the data processing terminal 105 may in one embodiment be configured to receive data directly from the transmitter unit 102 via the communication link, where the communication link, as described above, may be configured for bi-directional communication.

[0024] In this embodiment, the data processing terminal 105 which may include an insulin pump, may be configured to receive the analyte signals from the transmitter unit 102, and thus, incorporate the functions of the receiver unit 104 including data processing for managing the patient's insulin therapy and analyte monitoring. In one embodiment, the communication link 103 may include one or more of an RF communication protocol, an infrared communication protocol, a Bluetooth® enabled communication protocol, an 802.11x wireless communication protocol, or an equivalent wireless communication protocol which would allow secure, wireless communication of several units (for example, per HIPAA requirements) while avoiding potential data collision and interference.

[0025] FIG. 2 is a block diagram of the transmitter of the data monitoring and detection system shown in FIG. 1 in accordance with one embodiment of the present invention. Referring to the Figure, the transmitter unit 102 in one embodiment includes an analog interface 201 configured to communicate with the sensor 101 (FIG. 1), a user input 202, and a temperature detection section 203, each of which is operatively coupled to a transmitter processor 204 such as a central processing unit (CPU). As can be seen from FIG. 2, there are provided four contacts, three of which are electrodes—work electrode (W) 210, guard contact (G) 211, reference electrode (R) 212, and counter electrode (C) 213, each operatively coupled to the analog interface 201 of the transmitter unit 102 for connection to the sensor 101 (FIG. 1). In one embodiment, each of the work electrode (W) 210, guard contact (G) 211, reference electrode (R) 212, and counter electrode (C) 213 may be made using a conductive material that is either printed or etched, for example, such as carbon which may be printed, or metal foil (e.g., gold) which may be etched. Moreover, in a further aspect, the electrode layers may be disposed in a stacked configuration where, each of the working electrode 210, the reference electrode 212 and the counter electrode 213 may be disposed on a substrate layer with one or more dielectric layers disposed therebetween such that at least a portion of each of the electrodes are positioned on top of one another in a stacked or layered configuration.

[0026] Further shown in FIG. 2 are a transmitter serial communication section 205 and an RF transmitter 206, each of which is also operatively coupled to the transmitter processor 204. Moreover, a power supply 207 such as a battery is also provided in the transmitter unit 102 to provide the necessary power for the transmitter unit 102. Additionally, as can be seen from the Figure, clock 208 is provided to, among others, supply real time information to the transmitter processor 204.

[0027] In one embodiment, a unidirectional input path is established from the sensor 101 (FIG. 1) and/or manufacturing and testing equipment to the analog interface 201 of the transmitter unit 102, while a unidirectional output is established from the output of the RF transmitter 206 of the transmitter unit 102 for transmission to the primary receiver unit 104. In this manner, a data path is shown in FIG. 2 between the aforementioned unidirectional input and output via a dedicated link 209 from the analog interface 201 to serial communication section 205, thereafter to the processor 204, and then to the RF transmitter 206. As such, in one embodiment, via the data path described above, the transmitter unit 102 is configured to transmit to the primary receiver unit 104 (FIG. 1), via the communication link 103 (FIG. 1), processed and encoded data signals received from the sensor 101 (FIG. 1). Additionally, the unidirectional communication data path between the analog interface 201 and the RF transmitter 206 discussed above allows for the configuration of the transmitter unit 102 for operation upon completion of the manufacturing process as well as for direct communication for diagnostic and testing purposes.

[0028] As discussed above, the transmitter processor 204 is configured to transmit control signals to the various sections of the transmitter unit 102 during the operation of the transmitter unit 102. In one embodiment, the transmitter processor 204 also includes a memory (not shown) for storing data such as the identification information for the transmitter unit 102, as well as the data signals received from the sensor 101. The stored information may be retrieved and processed for transmission to the primary receiver unit 104 under the control of the transmitter processor 204. Furthermore, the power supply 207 may include a commercially available battery.

[0029] The transmitter unit 102 is also configured such that the power supply section 207 is capable of providing power to the transmitter for a minimum of about three months of continuous operation after having been stored for about eighteen months in a low-power (non-operating) mode. In one embodiment, this may be achieved by the transmitter processor 204 operating in low power modes in the non-operating state, for example, drawing no more than approximately 1  $\mu$ A of current. Indeed, in one embodiment, the final step during the manufacturing process of the transmitter unit 102 may place the transmitter unit 102 in the lower power, non-operating state (i.e., post-manufacture sleep mode). In this manner, the shelf life of the transmitter unit 102 may be significantly improved. Moreover, as shown in FIG. 2, while the power supply unit 207 is shown as coupled to the processor 204, and as such, the processor 204 is configured to provide control of the power supply unit 207, it should be noted that within the scope of the present invention, the power supply unit 207 is configured to provide the necessary power to each of the components of the transmitter unit 102 shown in FIG. 2.

[0030] Referring back to FIG. 2, the power supply section 207 of the transmitter unit 102 in one embodiment may include a rechargeable battery unit that may be recharged by a separate power supply recharging unit (for example, provided in the receiver unit 104) so that the transmitter unit 102 may be powered for a longer period of usage time. Moreover, in one embodiment, the transmitter unit 102 may be configured without a battery in the power supply section 207, in which case the transmitter unit 102 may be configured to receive power from an external power supply source (for example, a battery) as discussed in further detail below.

[0031] Referring yet again to FIG. 2, the temperature detection section 203 of the transmitter unit 102 is configured to monitor the temperature of the skin near the sensor insertion site. The temperature reading is used to adjust the analyte readings obtained from the analog interface 201. The RF transmitter 206 of the transmitter unit 102 may be configured for operation in the frequency band of 315 MHz to 322 MHz, for example, in the United States. Further, in one embodiment, the RF transmitter 206 is configured to modulate the carrier frequency by performing Frequency Shift Keying and Manchester encoding. In one embodiment, the data transmission rate is 19,200 symbols per second, with a minimum transmission range for communication with the primary receiver unit 104.

[0032] Referring yet again to FIG. 2, also shown is a leak detection circuit 214 coupled to the guard contact (G) 211 and the processor 204 in the transmitter unit 102 of the data monitoring and management system 100. The leak detection circuit 214 in accordance with one embodiment of the present invention may be configured to detect leakage current in the sensor 101 to determine whether the measured sensor data are corrupt or whether the measured data from the sensor 101 is accurate.

[0033] Additional detailed description of the continuous analyte monitoring system, its various components including the functional descriptions of the transmitter are provided in U.S. Pat. No. 6,175,752 issued Jan. 16, 2001 entitled "Analyte Monitoring Device and Methods of Use", and in U.S. patent application Ser. No. 10/745,878 filed Dec. 26, 2003, now U.S. Pat. No. 7,811,231, entitled "Continuous Glucose Monitoring System and Methods of Use", each assigned to the Assignee of the present application, the disclosure of each of which are incorporated herein by reference for all purposes.

[0034] FIG. 3 is a block diagram of the receiver/monitor unit of the data monitoring and management system shown in FIG. 1 in accordance with one embodiment of the present invention. Referring to FIG. 3, the primary receiver unit 104 includes a blood glucose test strip interface 301, an RF receiver 302, an input 303, a temperature detection section 304, and a clock 305, each of which is operatively coupled to a receiver processor 307. As can be further seen from the Figure, the primary receiver unit 104 also includes a power supply 306 operatively coupled to a power conversion and monitoring section 308. Further, the power conversion and monitoring section 308 is also coupled to the receiver processor 307. Moreover, also shown are a receiver serial communication section 309, and an output 310, each operatively coupled to the receiver processor 307.

[0035] In one embodiment, the test strip interface 301 includes a glucose level testing portion to receive a manual insertion of a glucose test strip, and thereby determine and display the glucose level of the test strip on the output 310

of the primary receiver unit 104. This manual testing of glucose can be used to calibrate sensor 101. The RF receiver 302 is configured to communicate, via the communication link 103 (FIG. 1) with the RF transmitter 206 of the transmitter unit 102, to receive encoded data signals from the transmitter unit 102 for, among others, signal mixing, demodulation, and other data processing. The input 303 of the primary receiver unit 104 is configured to allow the user to enter information into the primary receiver unit 104 as needed. In one aspect, the input 303 may include one or more keys of a keypad, a touch-sensitive screen, or a voice-activated input command unit. The temperature detection section 304 is configured to provide temperature information of the primary receiver unit 104 to the receiver processor 307, while the clock 305 provides, among others, real time information to the receiver processor 307.

[0036] Each of the various components of the primary receiver unit 104 shown in FIG. 3 is powered by the power supply 306 which, in one embodiment, includes a battery. Furthermore, the power conversion and monitoring section 308 is configured to monitor the power usage by the various components in the primary receiver unit 104 for effective power management and to alert the user, for example, in the event of power usage which renders the primary receiver unit 104 in sub-optimal operating conditions. An example of such sub-optimal operating condition may include, for example, operating the vibration output mode (as discussed below) for a period of time thus substantially draining the power supply 306 while the processor 307 (thus, the primary receiver unit 104) is turned on. Moreover, the power conversion and monitoring section 308 may additionally be configured to include a reverse polarity protection circuit such as a field effect transistor (FET) configured as a battery activated switch.

[0037] The serial communication section 309 in the primary receiver unit 104 is configured to provide a bi-directional communication path from the testing and/or manufacturing equipment for, among others, initialization, testing, and configuration of the primary receiver unit 104. Serial communication section 309 can also be used to upload data to a computer, such as time-stamped blood glucose data. The communication link with an external device (not shown) can be made, for example, by cable, infrared (IR) or RF link. The output 310 of the primary receiver unit 104 is configured to provide, among others, a graphical user interface (GUI) such as a liquid crystal display (LCD) for displaying information. Additionally, the output 310 may also include an integrated speaker for outputting audible signals as well as to provide vibration output as commonly found in handheld electronic devices, such as mobile telephones presently available. In a further embodiment, the primary receiver unit 104 also includes an electro-luminescent lamp configured to provide backlighting to the output 310 for output visual display in dark ambient surroundings.

[0038] Referring back to FIG. 3, the primary receiver unit 104 in one embodiment may also include a storage section such as a programmable, non-volatile memory device as part of the processor 307, or provided separately in the primary receiver unit 104, operatively coupled to the processor 307. The processor 307 is further configured to perform Manchester decoding as well as error detection and correction upon the encoded data signals received from the transmitter unit 102 via the communication link 103.

[0039] In a further embodiment, the one or more of the transmitter unit 102, the primary receiver unit 104, secondary receiver unit 106, or the data processing terminal/infusion section 105 may be configured to receive the blood glucose value wirelessly over a communication link from, for example, a glucose meter. In still a further embodiment, the user or patient manipulating or using the analyte monitoring system 100 (FIG. 1) may manually input the blood glucose value using, for example, a user interface (for example, a keyboard, keypad, and the like) incorporated in the one or more of the transmitter unit 102, the primary receiver unit 104, secondary receiver unit 106, or the data processing terminal/infusion section 105.

[0040] FIG. 4 is a schematic of the dynamic multi-stage signal amplification in the transmitter unit of the data monitoring and management system shown in FIG. 1 in accordance with one embodiment of the present invention. Referring to FIG. 4, there is provided in one embodiment a transimpedance amplifier 420 whose output terminal 423 is coupled to a first input terminal 411 of the analog to digital converter (ADC) 410 in the analog interface 201 (FIG. 2) of the transmitter unit 102. Further shown in FIG. 4, the monitored analyte sensor signal from the sensor 101 is provided to an inverting input terminal 421 of the transimpedance amplifier 420. The sensor signal in FIG. 4 is shown as a signal source 440. Furthermore, a noninverting input terminal 422 of the transimpedance amplifier 420 is provided with a reference voltage signal from a reference signal source  $V_{ref}$  450. In one embodiment, the reference voltage signal may be approximately 1.012 volts. However, based upon the component tolerance, and design configuration, other suitable reference voltage signals may be used.

[0041] In one aspect, based on the input analyte sensor signal from the signal source 440 and the reference signal  $V_{ref}$  450, the transimpedance amplifier 420 may be in one embodiment configured to convert the received current signal representing the monitored or detected analyte level, and to convert the current signal to a corresponding voltage signal which is provided to the output terminal 423 of the transimpedance amplifier 420. Further, as shown in FIG. 4 the monitored analyte voltage signal from the output terminal 423 of the transimpedance amplifier 420 is provided to the first input terminal 411 (Channel 1) of the ADC 410.

[0042] Referring again to FIG. 4, a second amplifier 430 is provided in one embodiment whose noninverting input terminal 431 is coupled to the output terminal 423 of the transimpedance amplifier 420 to receive the output voltage signal corresponding to the monitored analyte level, while an inverting input terminal 432 of the second amplifier 430 is coupled in one embodiment to the reference signal  $V_{ref}$  source 450. Moreover, output terminal 433 of the second amplifier is coupled in one embodiment to a second input terminal 412 (Channel 2) of the ADC 410. In operation, the second amplifier 430 may be configured to step up the output signal of the transimpedance amplifier 410 by a predetermined factor (for example, a factor of 2), and to provide the stepped up signal to the analog to digital converter (ADC) 410.

[0043] Referring back to FIG. 4, the analog to digital converter (ADC) 410 of the analog interface 201 (FIG. 2) of the transmitter unit 102 (FIG. 1) in one embodiment may be configured to detect signals at both the first and second input terminals or channels 411, 412, and based on one or more predetermined process or routine, the voltage signal at one

of the first or the second input terminals or channels 411, 412 is used by the ADC 410 for further processing as corresponding to the monitored analyte level from the sensor 101 (FIG. 1). That is, in one embodiment, depending upon the signal resolution corresponding to the analyte level monitored, the ADC 410 may be configured to select one of the output signals from the transimpedance amplifier 420 or the second amplifier 430 for further processing.

[0044] For example, when the signal received at the second input terminal 412 of the ADC 410 exceeds a predetermined threshold value, the input signal at the first input terminal 411 may be used. More specifically, in one embodiment, the ADC 410 may be configured to process the signals at the second input terminal 412 (Channel 2) since it has a higher resolution compared to the signal at the first input terminal 411 received from the transimpedance amplifier 420. When the signal received at the second input terminal 412 exceeds a predetermined threshold level (for example, based on the tolerance level of the analog to digital converter (ADC) 410), the voltage signal received at the first input terminal 411 from the transimpedance amplifier 420 may be used to convert to a corresponding digital signal representing the monitored analyte level detected by the sensor 101 (FIG. 1).

[0045] Referring back to FIG. 4, in one embodiment, the analog to digital converter (ADC) 410 may include a 12 bit A/D converter configured to support up to approximately 4,096 bits or ADC counts. In this case, in one embodiment, when the signal at the second input terminal 412 of the ADC 410 approaches approximately 4,000 bits or ADC counts, for example, the processor 204 (FIG. 2) of the transmitter unit 102 may be configured to switch from the second input terminal 412 to the first input terminal 411, to use the output signal from the transimpedance amplifier 420. In this manner, in one embodiment, the processor 204 of the transmitter unit 102 may be configured to monitor the signal levels at the two input terminals 411, 412 of the ADC 410, and when the signal level or ADC count associated with the output signal from the second amplifier 430 provided at the second input terminal 412 of the ADC 410 exceeds the predetermined threshold (for example, 4,000 bits or ADC count), the processor 204 may be configured to switch over to the output signal of the transimpedance amplifier 410 provided on the first input terminal 411 of the ADC 410 for further processing.

[0046] In the manner described above, the dynamic multi-stage amplifier configuration in one embodiment may be configured to support variations in the analyte sensor sensitivities due to, for example, manufacturing variations, among others, while maintaining an acceptable or desirable sensor signal resolution. For example, in one embodiment, high sensitivity sensors may be configured for use with the full scale or range (for example, up to approximately 150 nA corresponding to the supported approximately 500 mg/dL glucose level) associated with the transimpedance amplifier 420 output signal provided to the first input terminal 411 (Channel 1) of the analog to digital converter (ADC) 410, while low sensitivity sensors may be associated with the second amplifier 430 output signal (for example, full scale current signal level of approximately 75 nA corresponding to the supported approximately 500 mg/dL glucose level) provided to the second input terminal 412 (Channel 2) of the analog to digital converter (ADC) 410.

[0047] For example, as discussed above, in one embodiment, the processor 204 of the transmitter unit 102 may be configured to monitor the signals at the two input terminals 411, 412 of the ADC 410, and determine, that if the received signal level does not have sufficient resolution to convert to the desired resolution of the digital signal (for example, 12 bits for the ADC 410) corresponding to the monitored analyte level associated with the sensor 101, the processor 204 may be configured to dynamically toggle or switch from using the voltage signal received from one of the two input terminals 411, 412, to using the voltage signal from the other one of the two input terminals 411, 412 to provide a dynamic range of tolerance level for the sensor sensitivities.

[0048] Accordingly, an apparatus in one embodiment includes a first amplifier having at least one input terminal and an output terminal, the at least one input terminal coupled to a signal source, the output terminal configured to provide a first output signal, a second amplifier having at least one input terminal and an output terminal, the at least one input terminal coupled to the output terminal of the first amplifier, the output terminal of the second amplifier configured to provide a second output signal, a processor operatively coupled to receive the first output signal and the second output signal, where the first output signal is a predetermined ratio of the second output signal, and further, where the first output signal and the second output signal are associated with a monitored analyte level of a user.

[0049] In one aspect, the first amplifier may include a transimpedance amplifier.

[0050] The monitored analyte level may include glucose level.

[0051] Also, the at least one input terminal of the first amplifier may include an inverting input terminal, and, also may include a reference signal source coupled to a noninverting input terminal of the first amplifier.

[0052] In a further aspect, the second amplifier may include a gain of approximately two.

[0053] In still another aspect, the first output signal may be associated with a signal level from the signal source.

[0054] The apparatus may also include an analog to digital converter coupled to the output terminals of the first and second amplifiers, where the analog to digital (A/D) converter may include a 12 bit A/D converter.

[0055] The apparatus in another embodiment may include a processor operatively coupled to the A/D converter for processing the one or more signals received at the one or more first amplifier output terminal and the second amplifier output terminal.

[0056] Moreover, the processor may be configured to compare the one or more signals received at the one or more first amplifier output terminal and the second amplifier output terminal to a predetermined threshold value, which, in one embodiment may include approximately 4,000 bits (or analog to digital converter (ADC) counts).

[0057] Still further, the processor may be configured to process a signal associated with one of the one or more signals received at the one or more first amplifier output terminal and the second amplifier output terminal when another signal associated with the other one of the one or

more signals received at the one or more first amplifier output terminal and the second amplifier output terminal exceeds the predetermined threshold value.

[0058] A method in accordance with another embodiment includes receiving a first signal having a first signal resolution and associated with a monitored analyte level of a user, receiving a second signal having a second signal resolution and associated with the monitored analyte level of the user, comparing the received first signal to a predetermined threshold level, and processing one of the received first or second signals based on the comparing step.

[0059] When the received first signal does not exceed the predetermined threshold level, further including processing the first signal. On the other hand, when the received first signal exceeds the predetermined threshold level, further including processing the second signal.

[0060] A data processing device in accordance with still another embodiment includes a multi stage amplifier unit configured to receive a signal and to generate a plurality of amplifier unit output signals each corresponding to a monitored analyte level of a patient, an analog to digital (A/D) conversion unit operatively coupled to the multi-stage amplifier unit configured to digitally convert the plurality of amplifier unit output signals, and a processor unit operatively coupled to the A/D conversion unit, the processor unit configured to process one of the plurality of digitally converted amplifier unit output signals.

[0061] The device in another aspect may include a data communication unit operatively coupled to the processor unit, and configured to transmit the digitally converted and processed amplifier unit output signal.

[0062] The data communication unit may include an RF transmitter for wireless data transmission to a remote device such as, for example, a data receiver unit, data processing terminal, an infusion device or the like configured for RF communication.

[0063] Various other modifications and alterations in the structure and method of operation of this invention will be apparent to those skilled in the art without departing from the scope and spirit of the invention. Although the invention has been described in connection with specific preferred embodiments, it should be understood that the invention as claimed should not be unduly limited to such specific embodiments. It is intended that the following claims define the scope of the present invention and that structures and methods within the scope of these claims and their equivalents be covered thereby.

What is claimed is:

1. A method of processing signals from an analyte sensor, comprising:

coupling a first amplifier to a second amplifier and a signal source;

comparing signals at an output terminal of the second amplifier to a predetermined threshold value; and

processing a signal associated with the signals at the second amplifier output terminal when another signal at the second amplifier output terminal exceeds the predetermined threshold value.

\* \* \* \* \*

专利名称(译)	用于在医疗设备中提供动态多级信号放大的方法和装置		
公开(公告)号	<a href="#">US20160317071A1</a>	公开(公告)日	2016-11-03
申请号	US15/209741	申请日	2016-07-13
[标]申请(专利权)人(译)	雅培糖尿病护理公司		
申请(专利权)人(译)	雅培糖尿病INC.		
当前申请(专利权)人(译)	雅培糖尿病INC.		
[标]发明人	FENNELL MARTIN J		
发明人	FENNELL, MARTIN J.		
IPC分类号	A61B5/145 A61B5/1486 A61M5/172 A61B5/00		
CPC分类号	A61B5/14532 A61B5/7225 A61B5/0004 A61B5/002 A61B5/14546 A61B2560/045 A61B5/7246 A61B5/7475 A61M5/1723 A61B2560/0209 A61B2560/0252 A61B5/14865		
优先权	60/911866 2007-04-14 US		
其他公开文献	US9743866		
外部链接	<a href="#">Espacenet</a> <a href="#">USPTO</a>		

摘要(译)

提供了用于在医疗遥测系统中提供多级信号放大的方法和装置。

