



(19) **United States**

(12) **Patent Application Publication**
Monfre

(10) **Pub. No.: US 2019/0015023 A1**
(43) **Pub. Date: Jan. 17, 2019**

(54) **MEDICAL MONITORING DEVICE FOR HARMONIZING PHYSIOLOGICAL MEASUREMENTS**

(52) **U.S. Cl.**
CPC *A61B 5/14532* (2013.01); *A61B 5/0075* (2013.01); *A61B 5/7203* (2013.01); *A61B 5/0295* (2013.01); *A61B 5/7278* (2013.01); *A61B 2560/0223* (2013.01); *A61B 5/0205* (2013.01)

(71) Applicant: **Cercacor Laboratories, Inc.**, Irvine, CA (US)

(72) Inventor: **Stephen Leonard Monfre**, Lawrenceville, NJ (US)

(57) **ABSTRACT**

(21) Appl. No.: **16/034,743**

(22) Filed: **Jul. 13, 2018**

Systems, methods, apparatuses, and medical devices for harmonizing data from a plurality of non-invasive sensors are described. A physiological parameter can be determined by harmonizing data between two or more different types of non-invasive physiological sensors interrogating the same or proximate measurement sites. Data from one or more first non-invasive sensors can be utilized to identify one or more variables that are useful in one or more calculations associated with data from one or more second non-invasive sensors. Data from one or more first non-invasive sensors can be utilized to calibrate one or more second non-invasive sensors. Non-invasive sensors can include, but are not limited to, an optical coherence tomography (OCT) sensor, a bio-impedance sensor, a tissue dielectric constant sensor, a plethysmograph sensor, or a Raman spectrometer.

Related U.S. Application Data

(60) Provisional application No. 62/532,273, filed on Jul. 13, 2017, provisional application No. 62/667,983, filed on May 7, 2018.

Publication Classification

(51) **Int. Cl.**
A61B 5/145 (2006.01)
A61B 5/00 (2006.01)
A61B 5/0205 (2006.01)

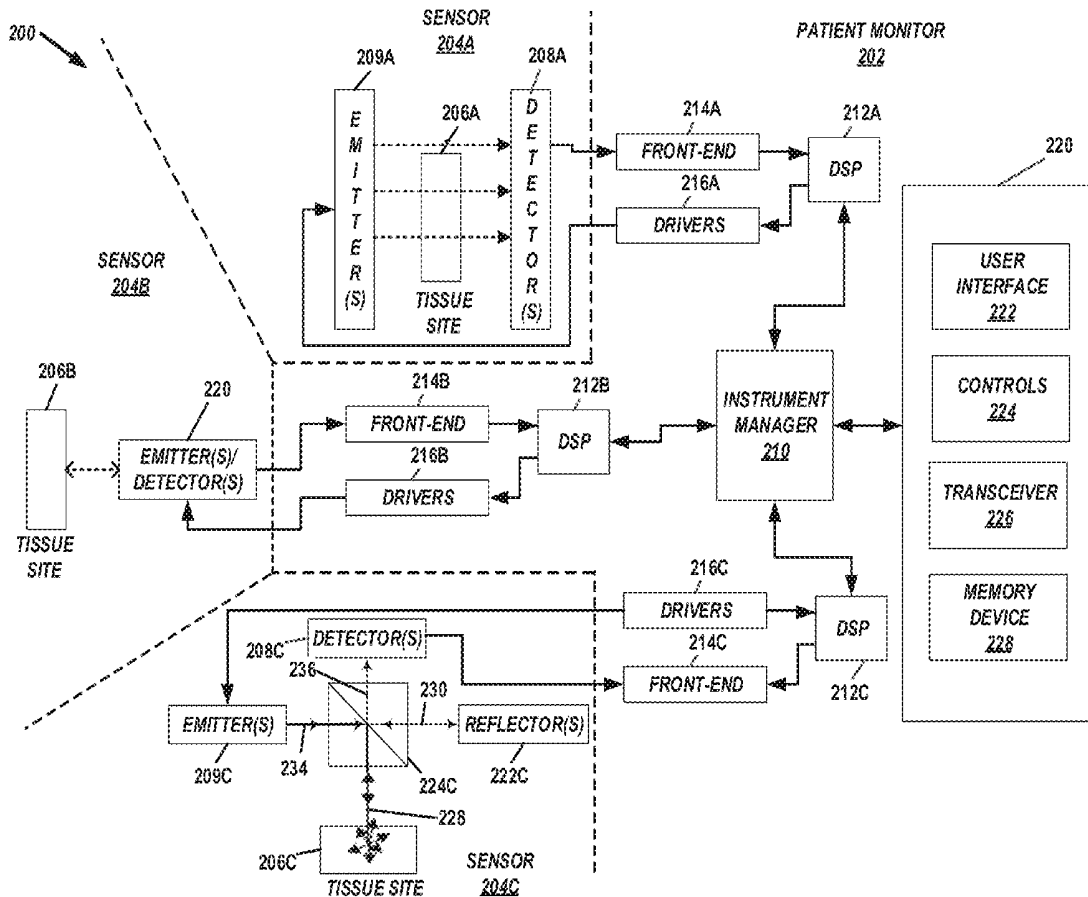

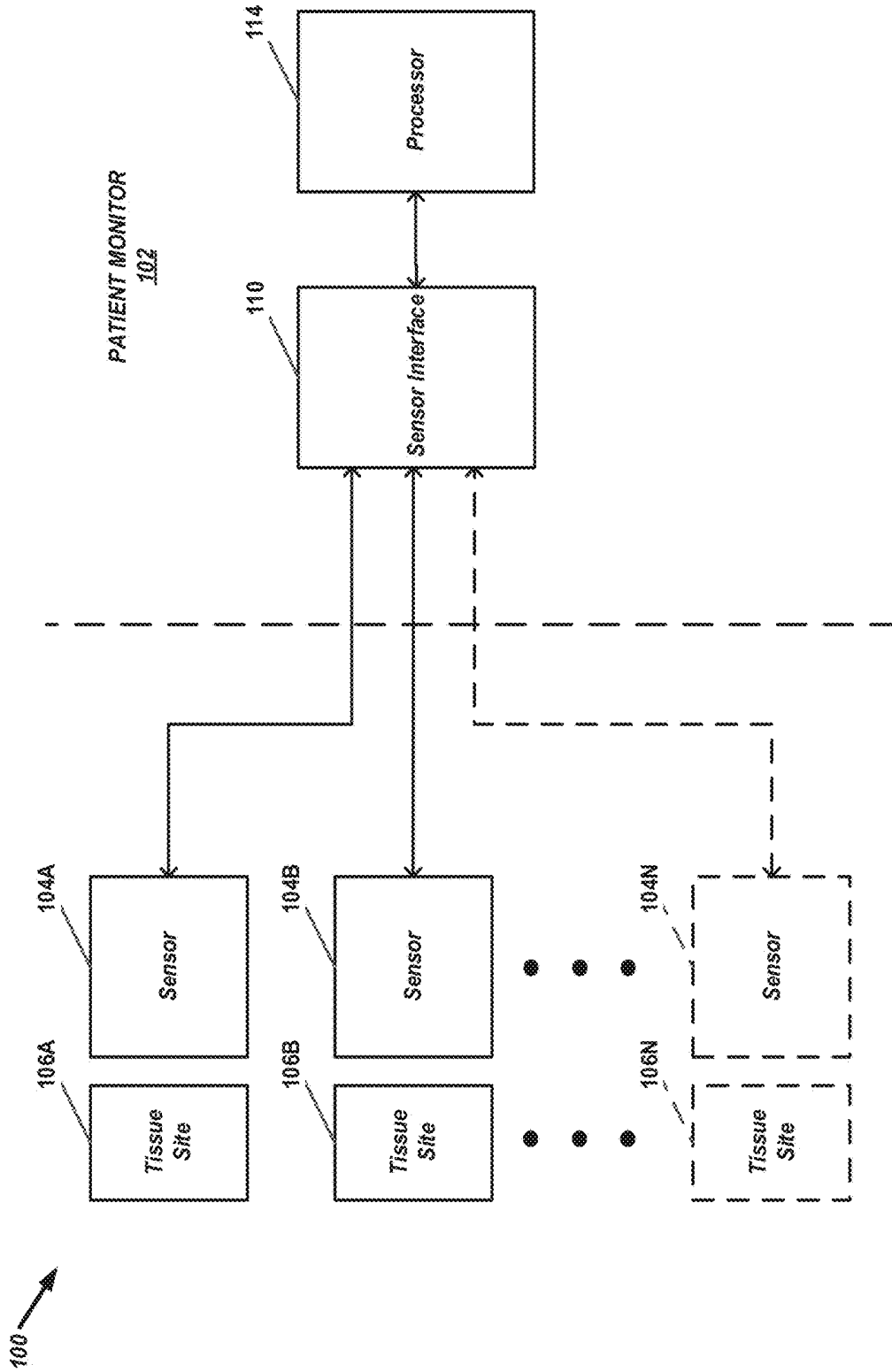

FIG. 1

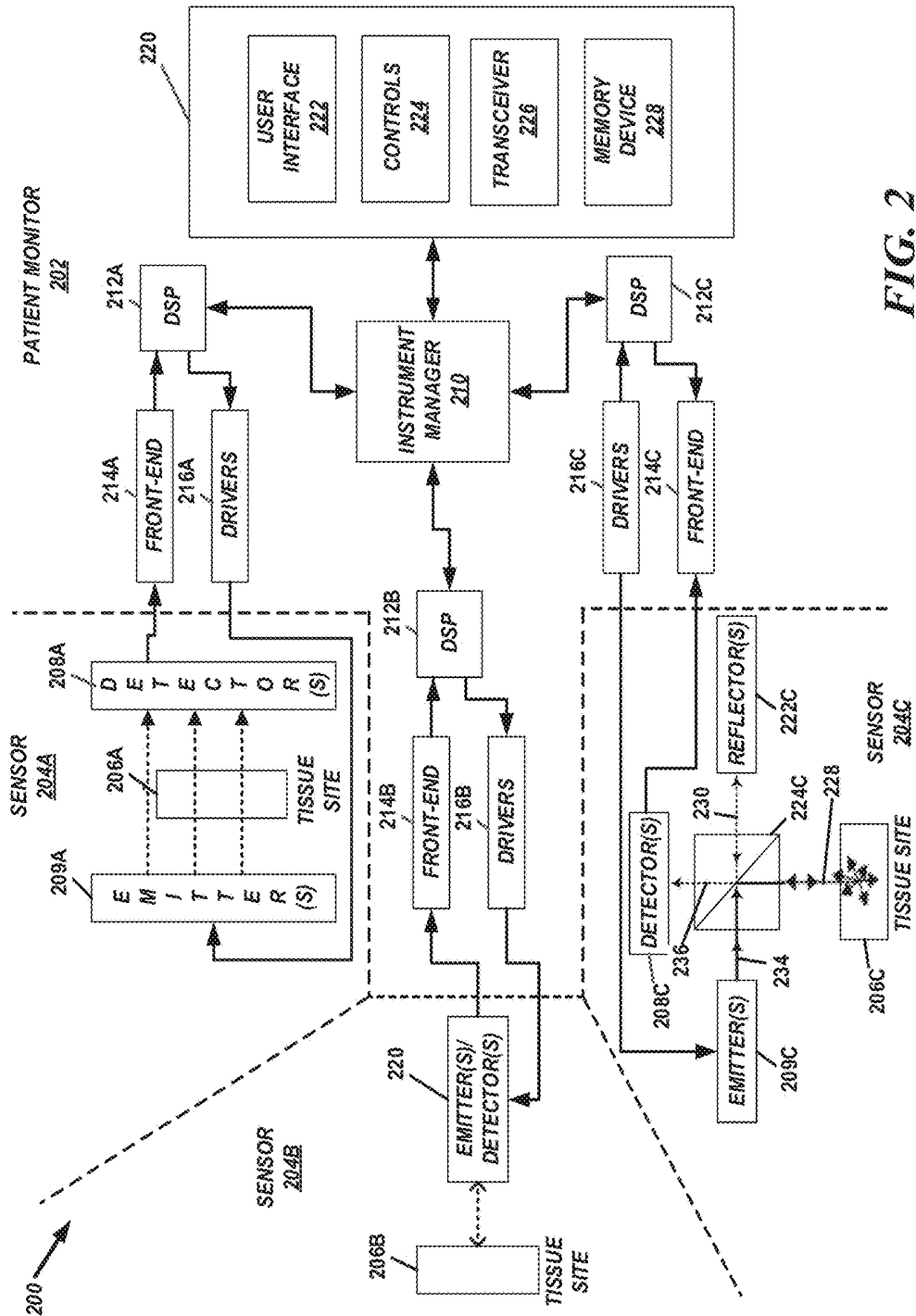

FIG. 2

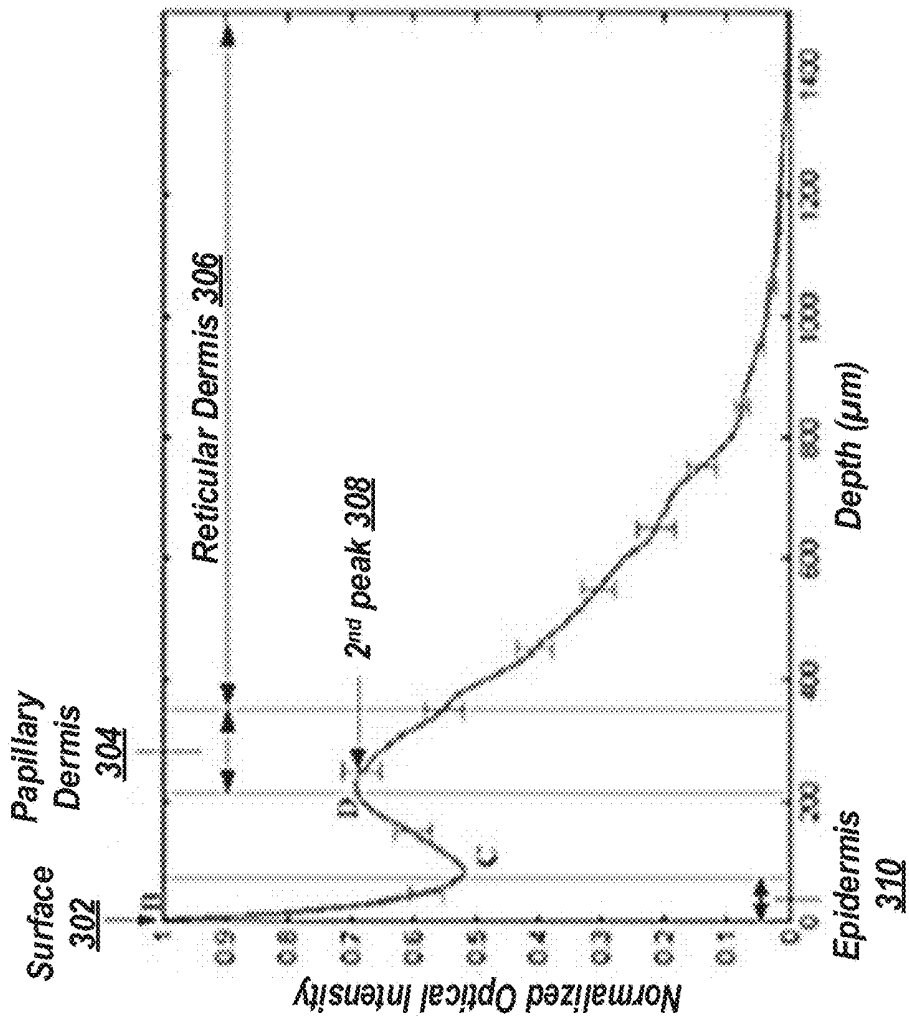

Fig. 3B

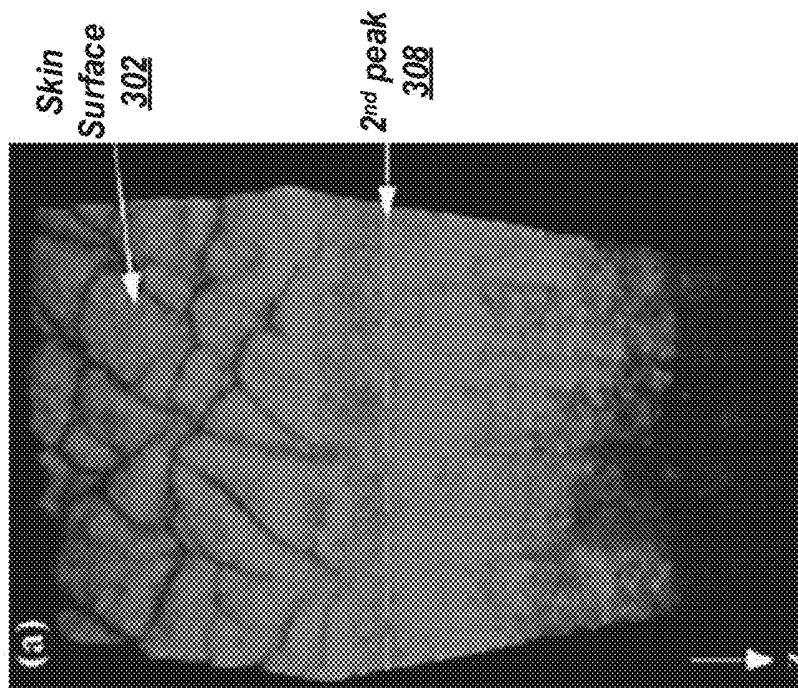

Fig. 3A

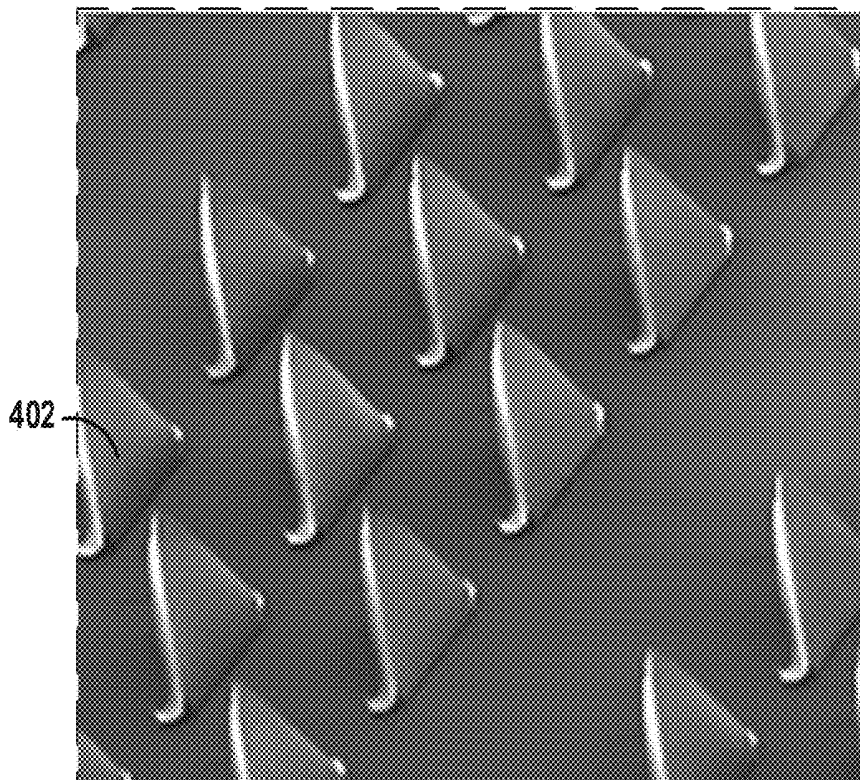

FIG. 4

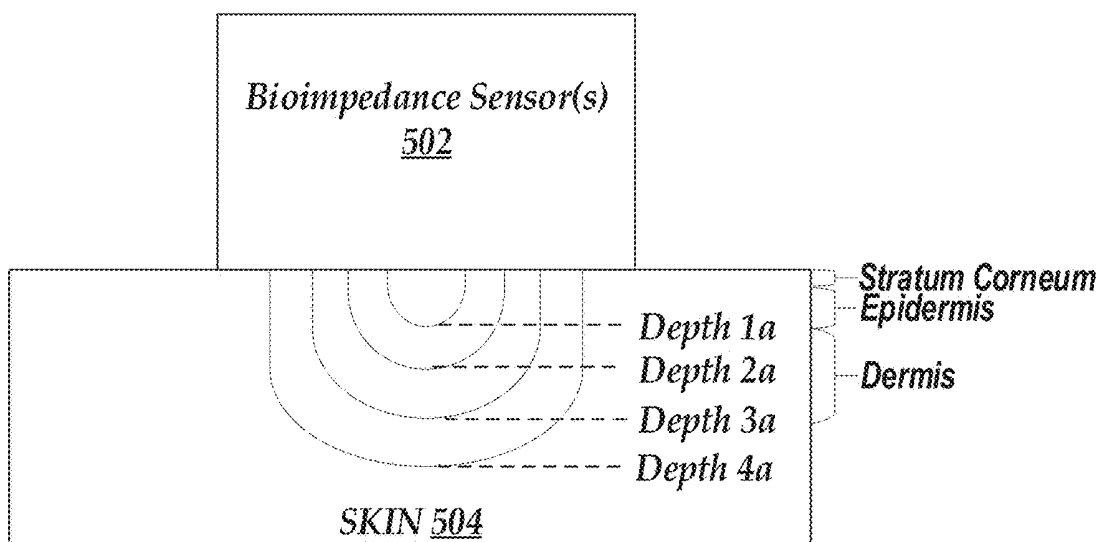

FIG. 5

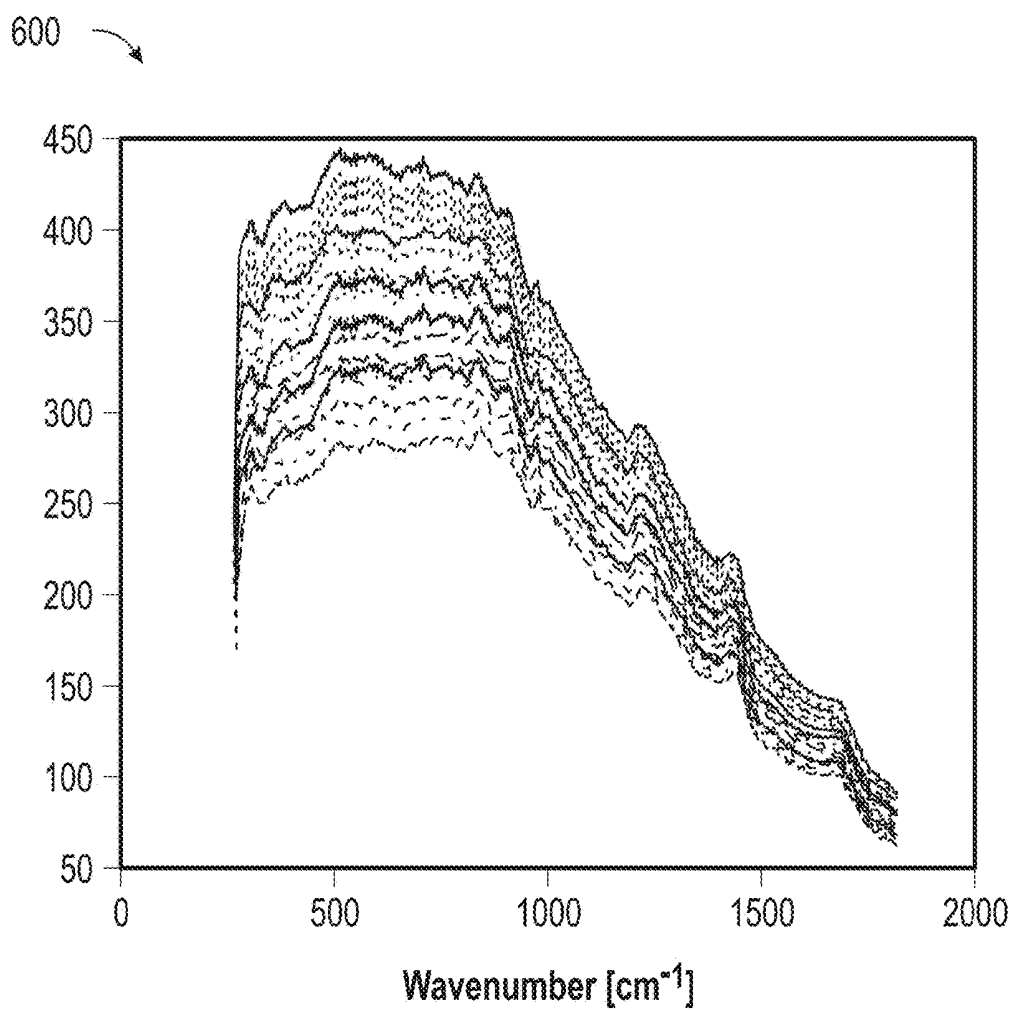

FIG. 6

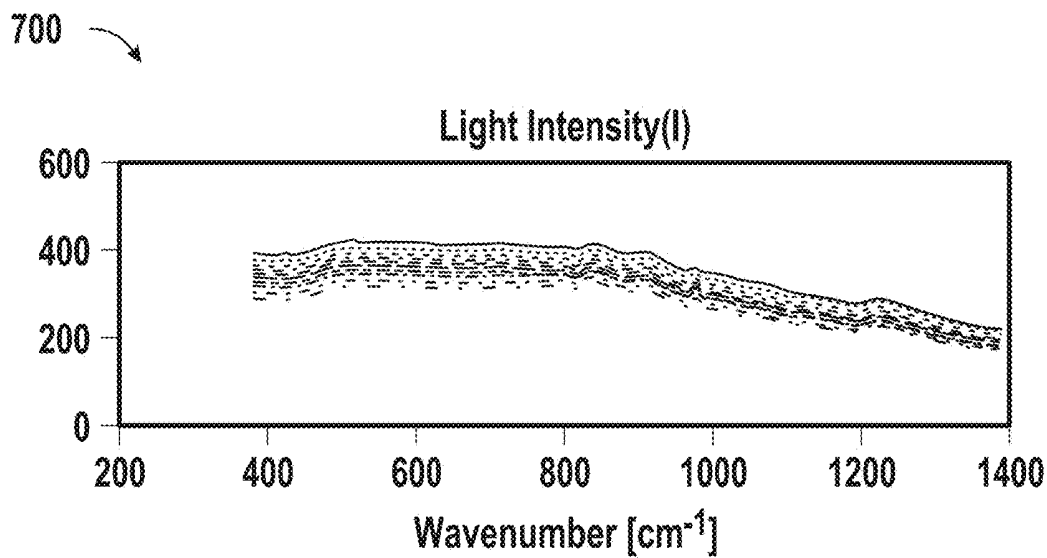

FIG. 7

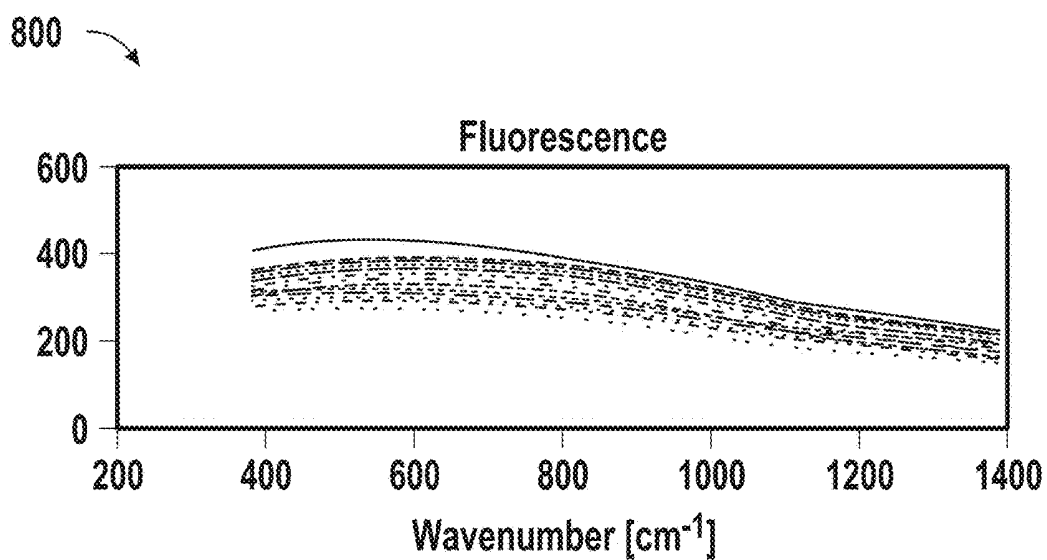

FIG. 8

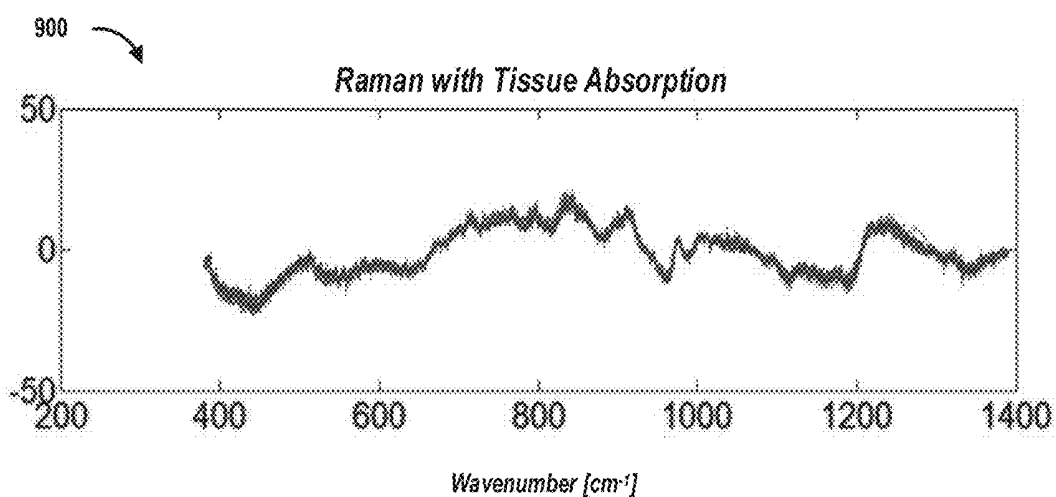

FIG. 9

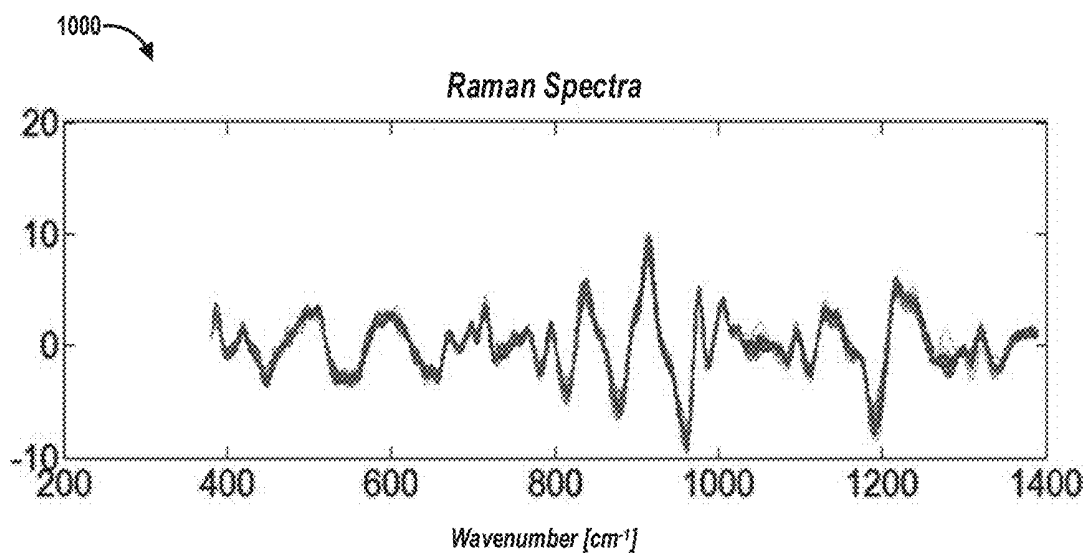

FIG. 10

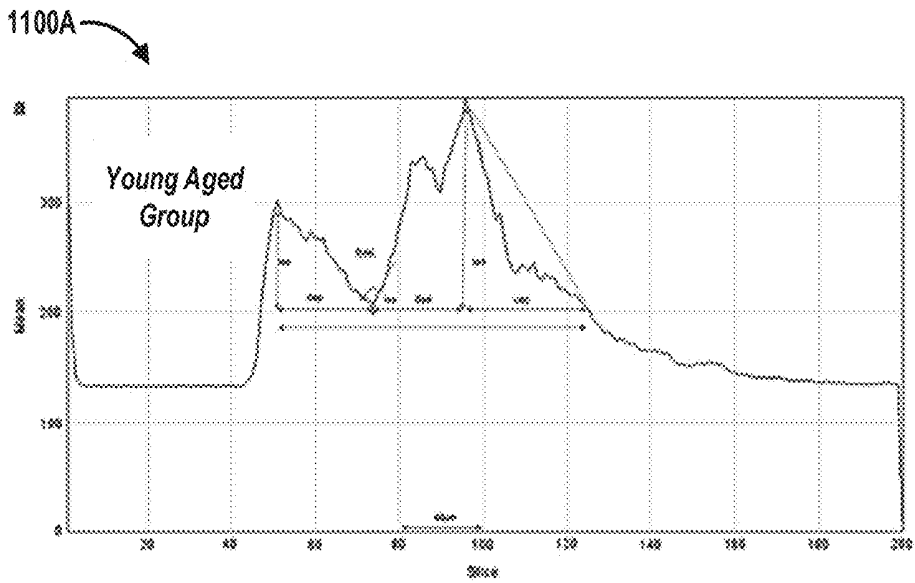

FIG. 11A

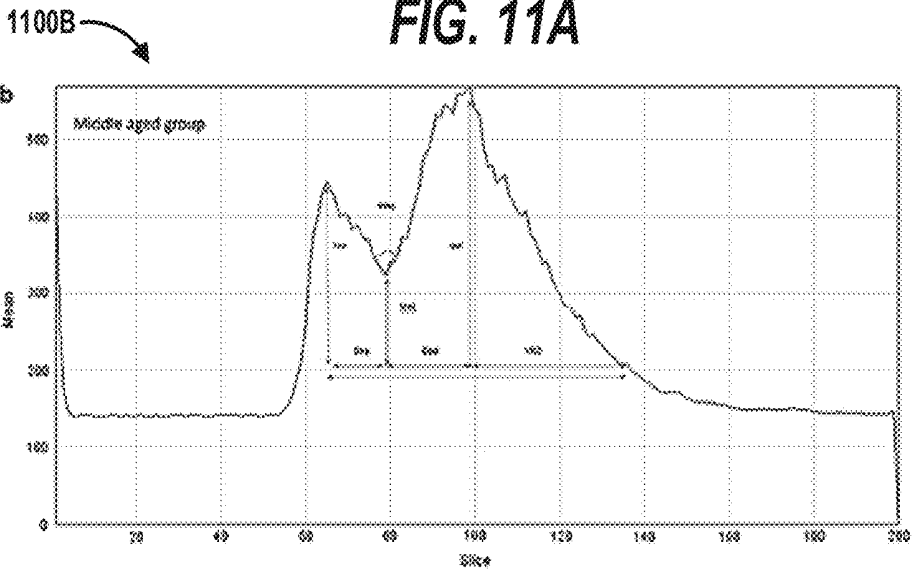

FIG. 11B

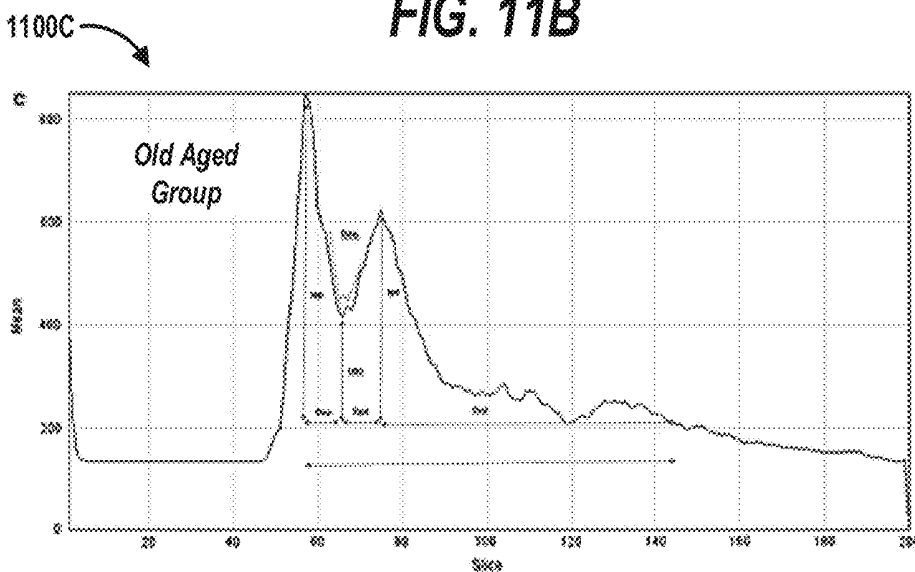

FIG. 11C

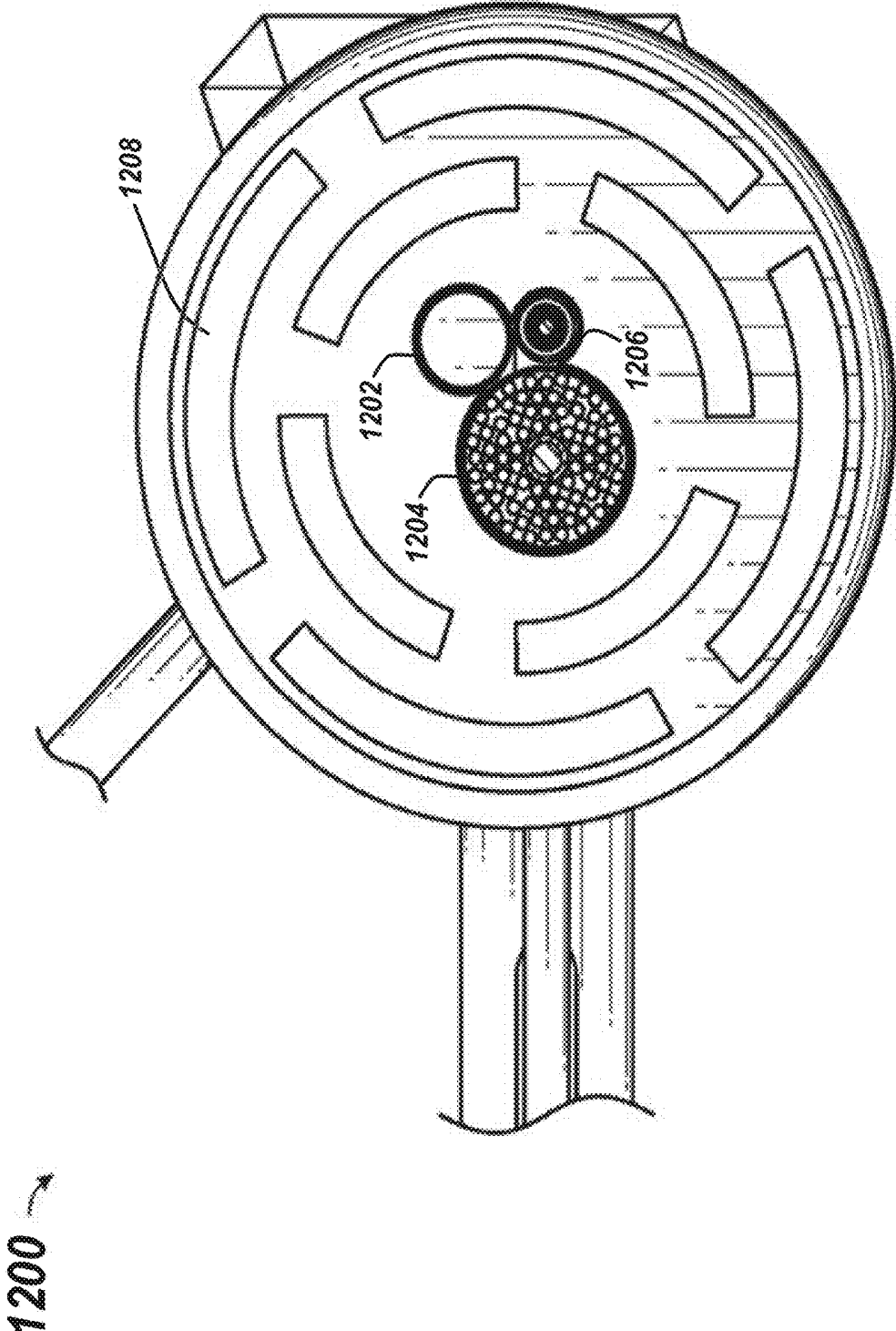

FIG. 12A

1200 →

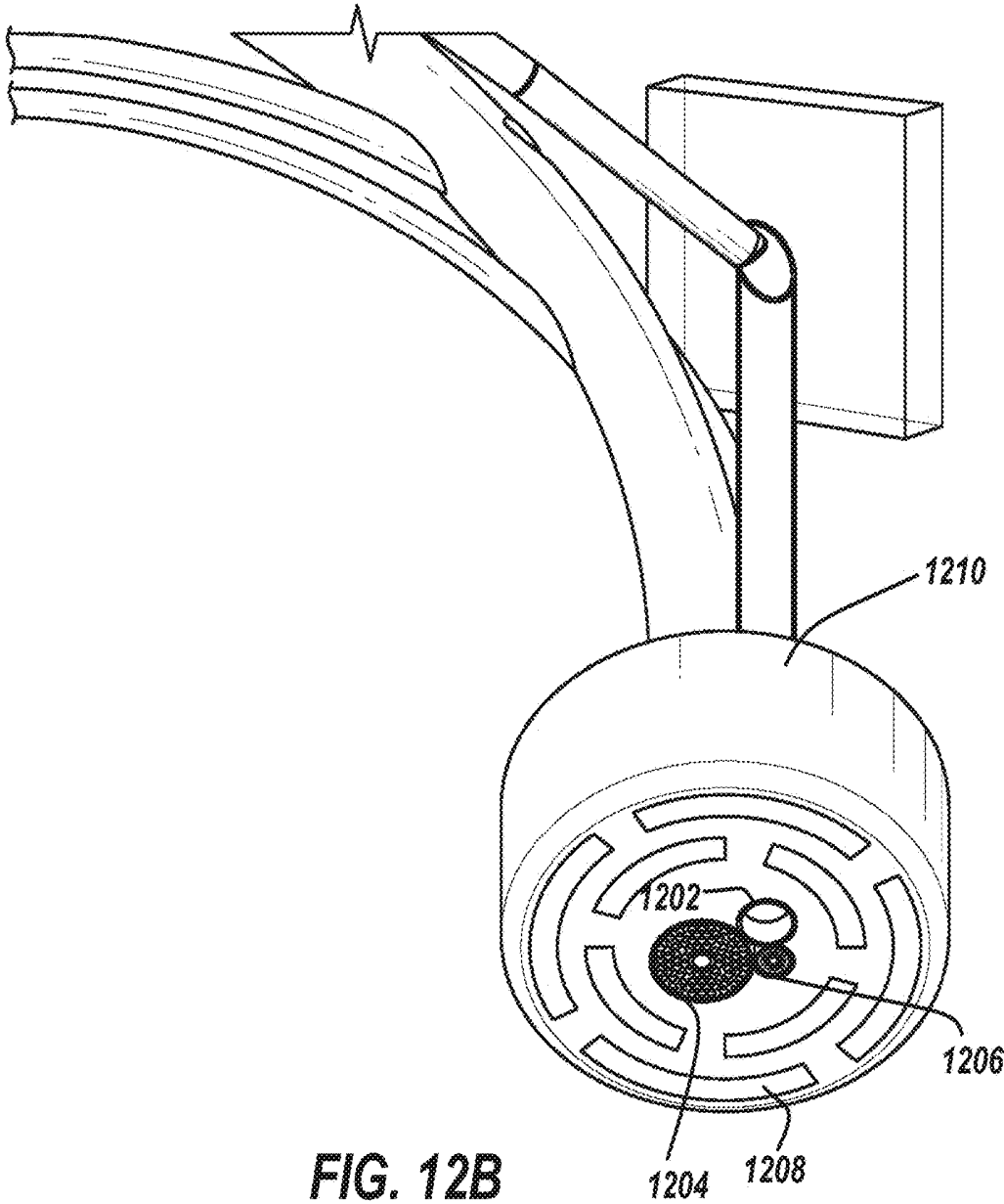

FIG. 12B

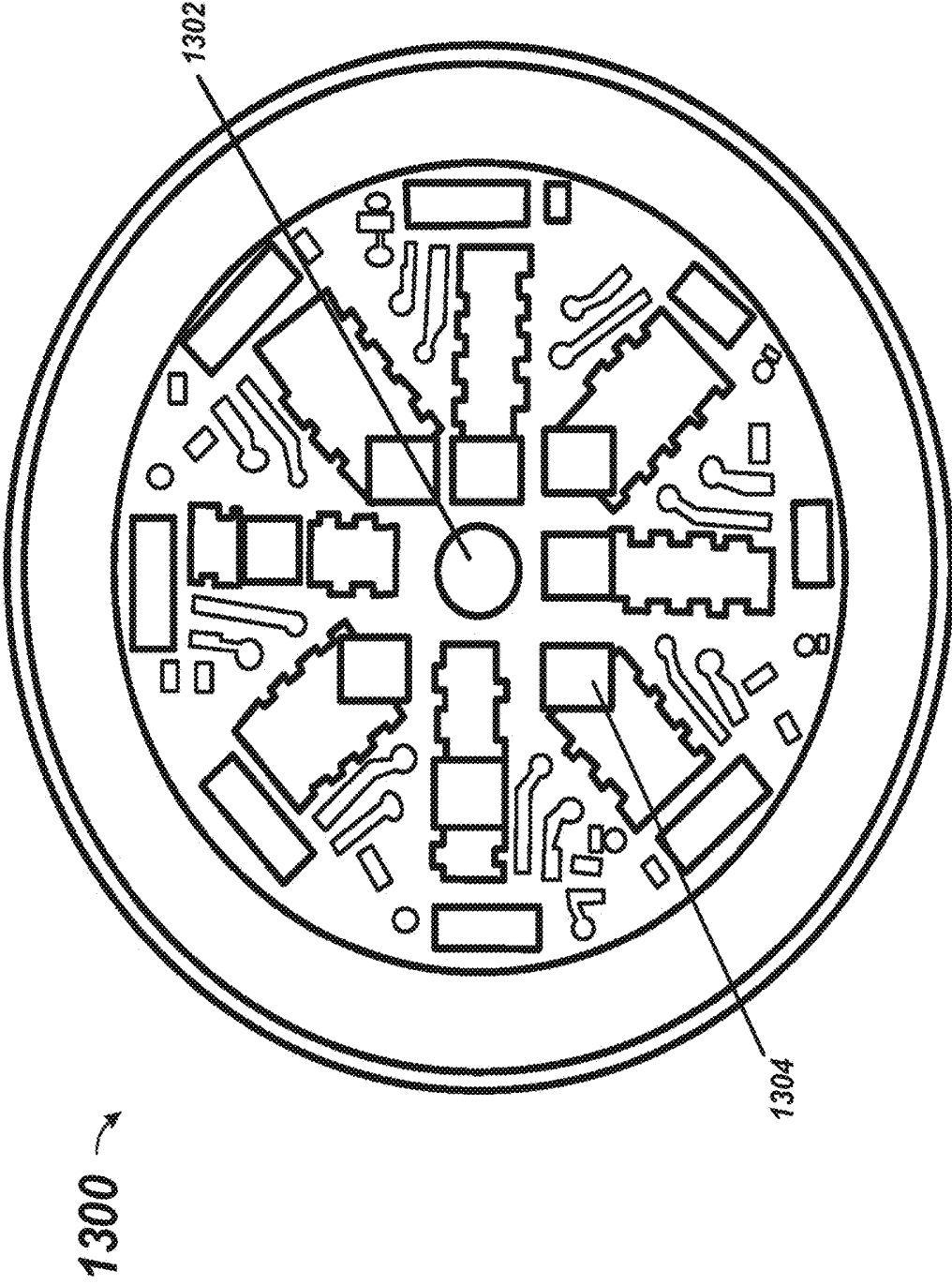

FIG. 13

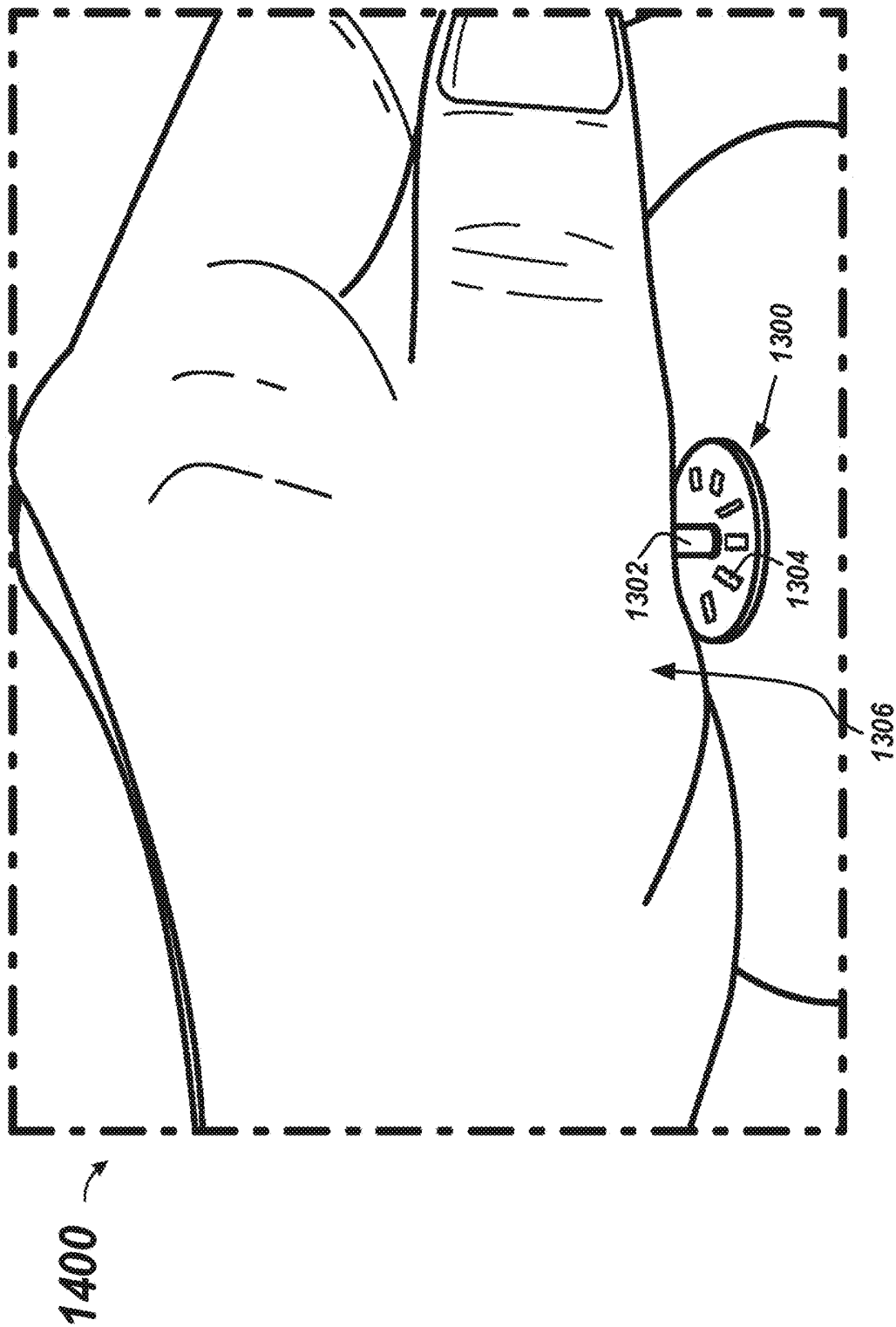

FIG. 14

1500 →

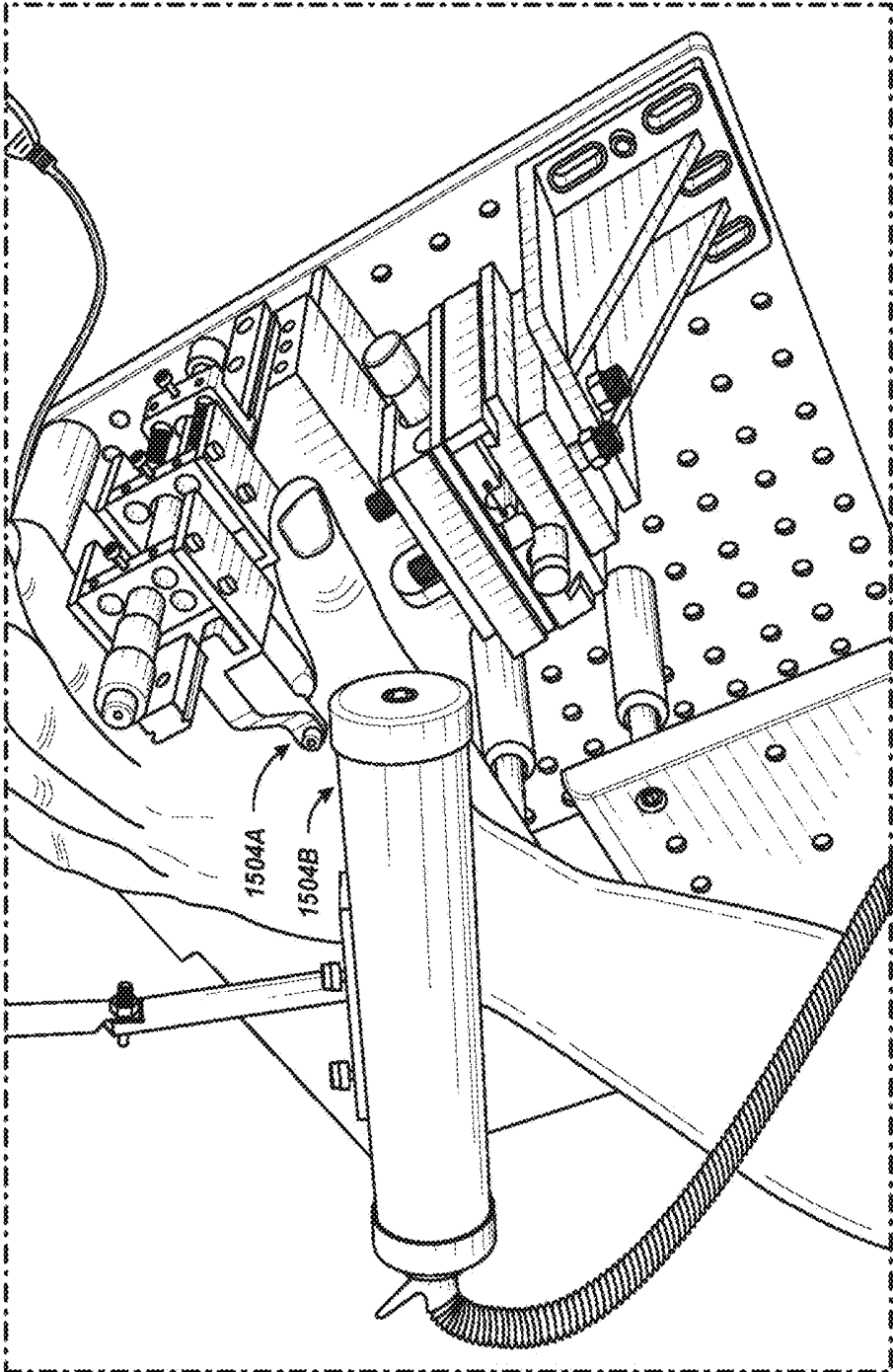
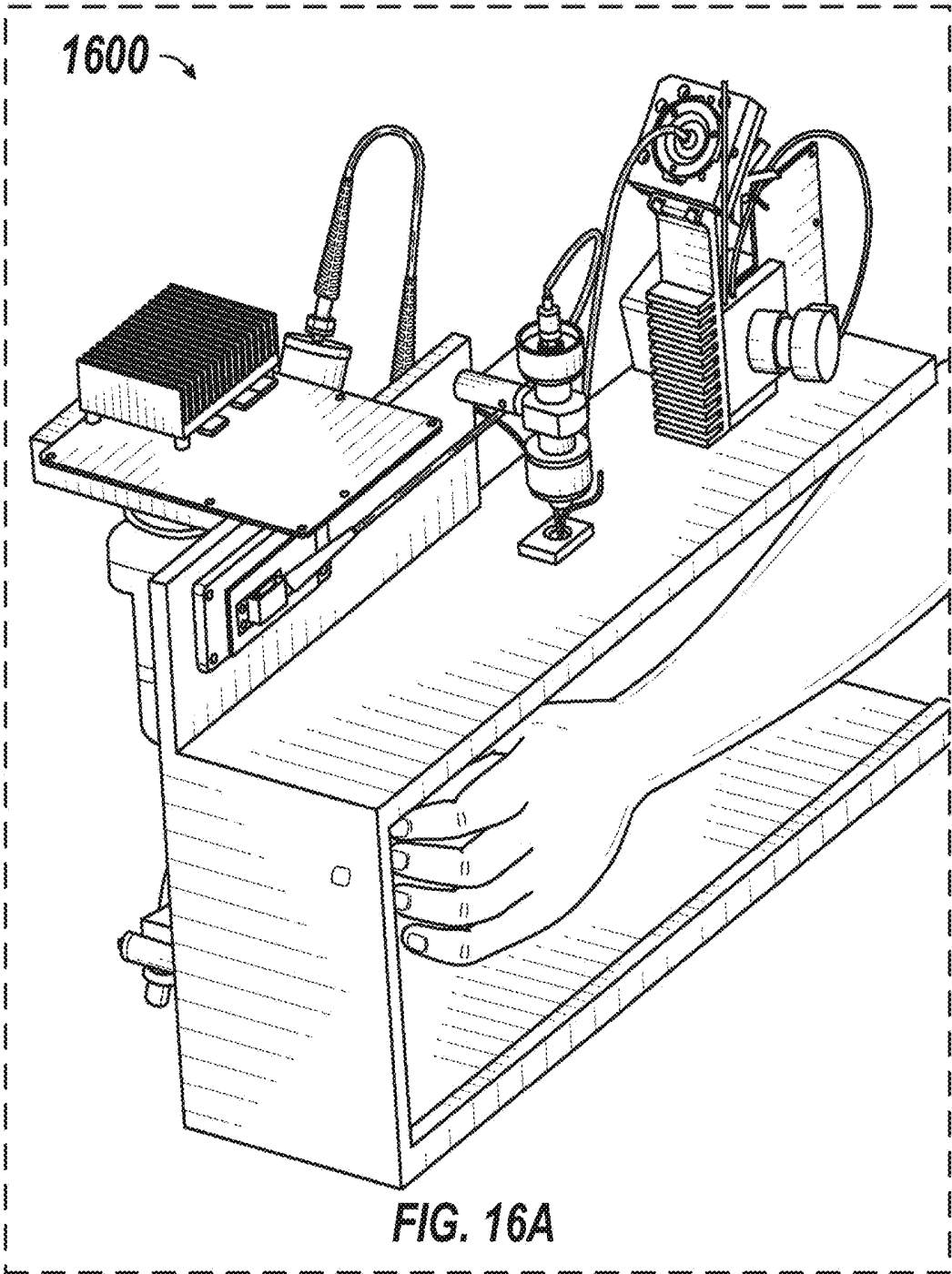
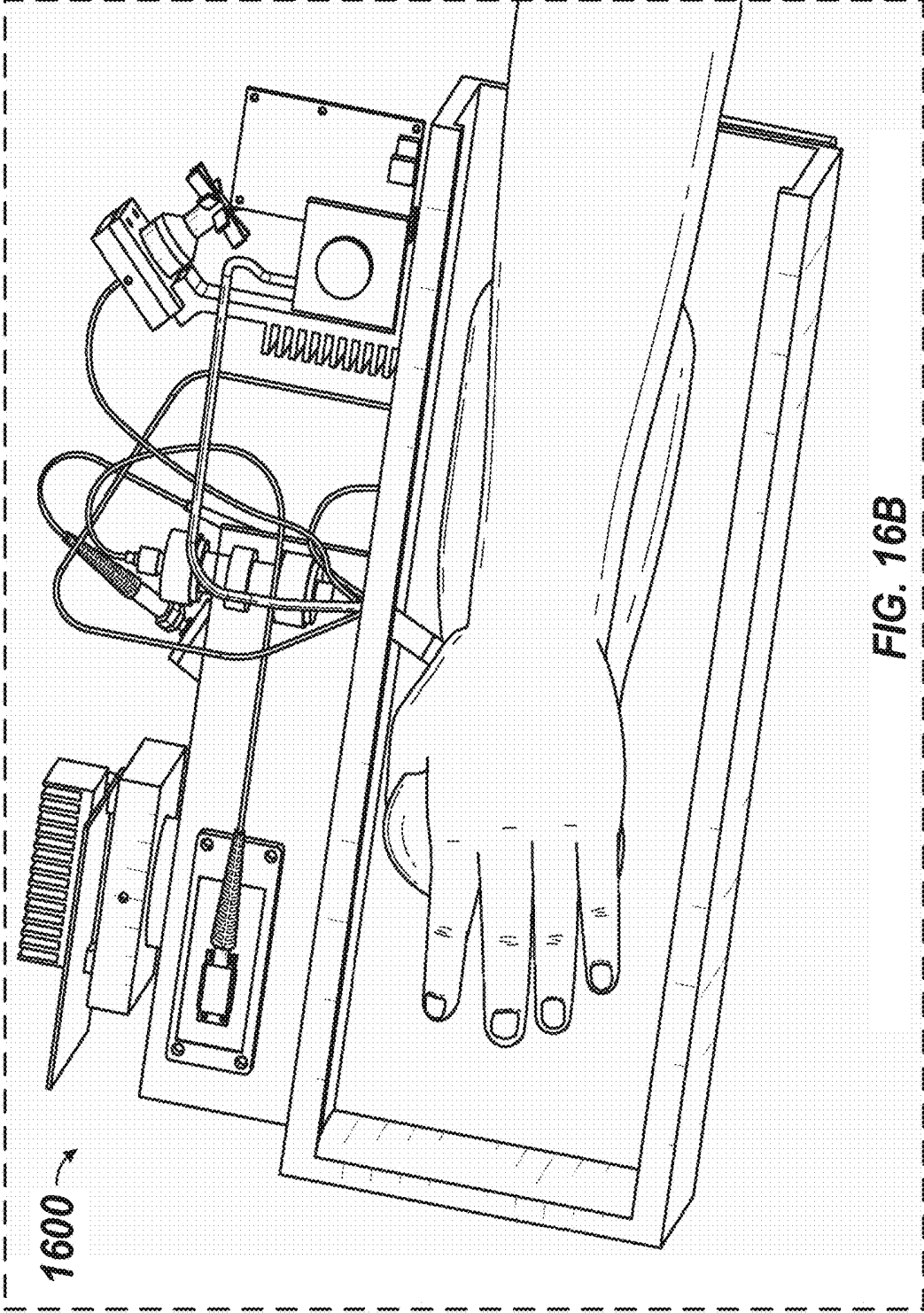

FIG. 15





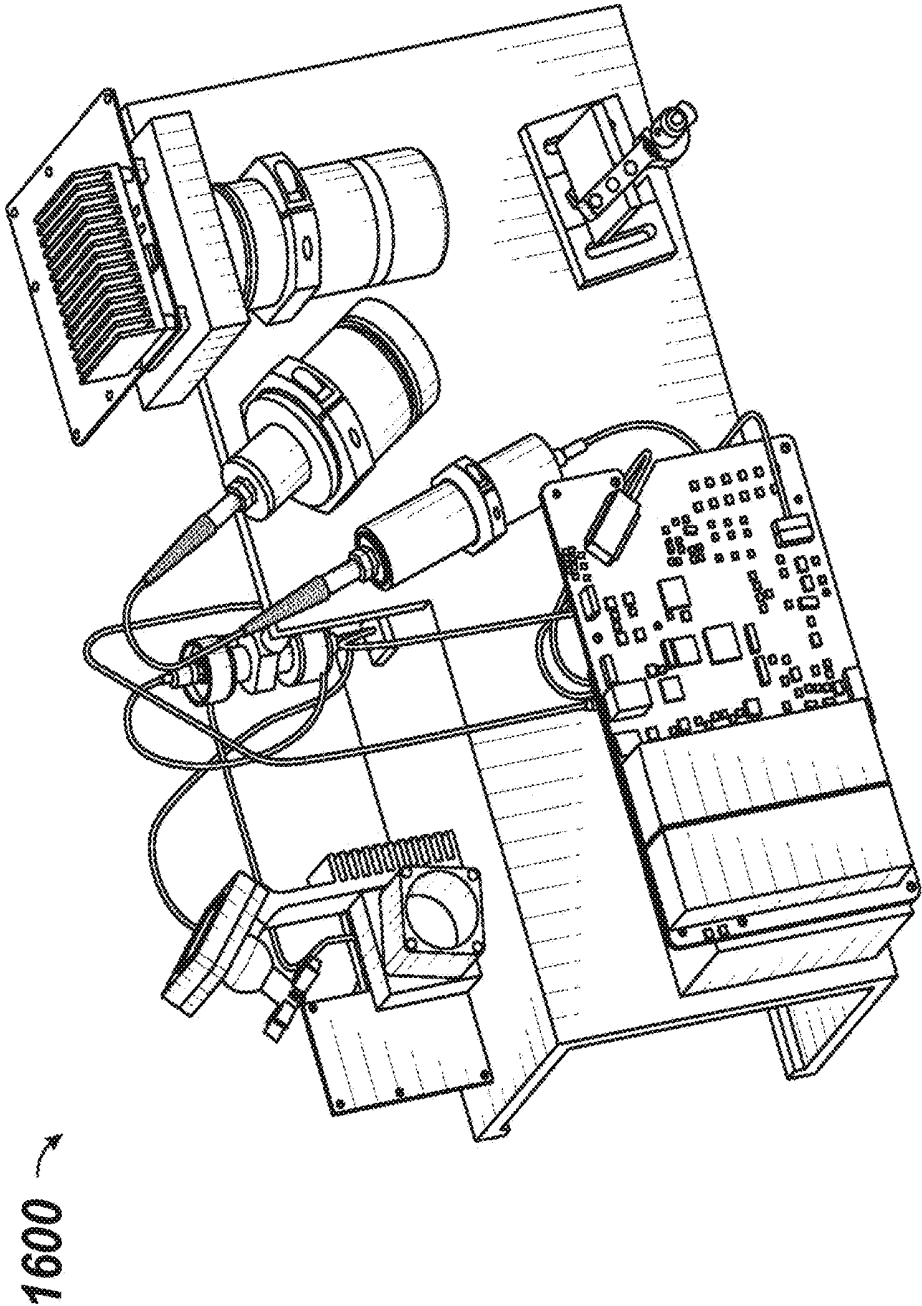

FIG. 16C

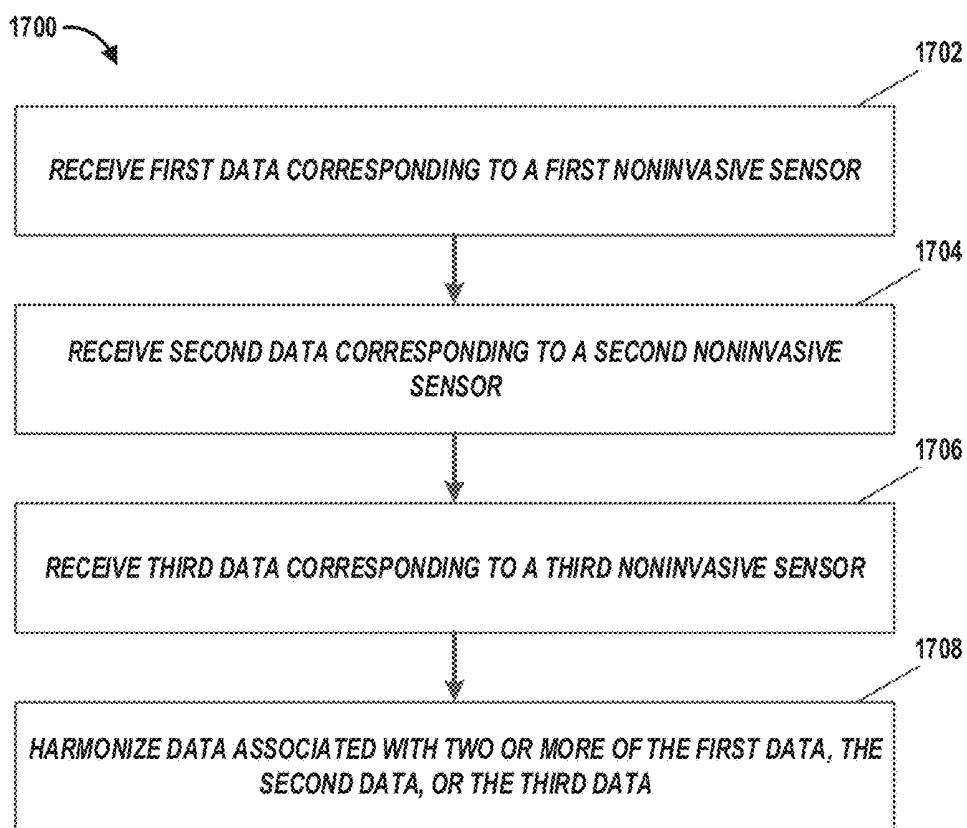

FIG. 17

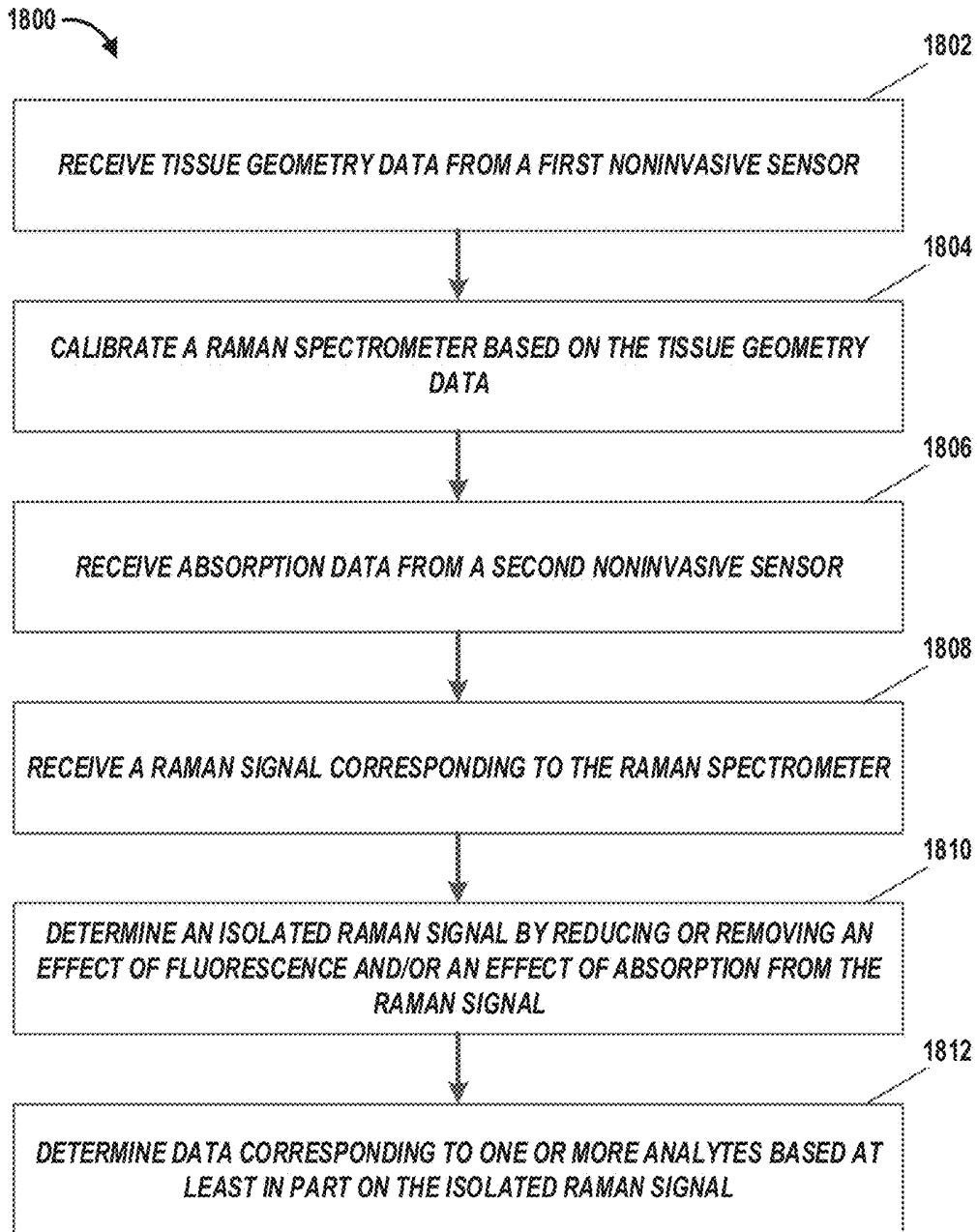

FIG. 18

MEDICAL MONITORING DEVICE FOR HARMONIZING PHYSIOLOGICAL MEASUREMENTS

CROSS-REFERENCE TO RELATED APPLICATIONS

[0001] The present application claims priority benefit to U.S. Provisional Application No. 62/532,273, entitled “MEDICAL MONITORING DEVICE FOR COORDINATING PHYSIOLOGICAL MEASUREMENTS,” filed Jul. 13, 2017, and U.S. Provisional Application No. 62/667,983, entitled “MEDICAL MONITORING DEVICE FOR HARMONIZING PHYSIOLOGICAL MEASUREMENTS,” filed May 7, 2018, each of which is hereby incorporated herein by reference in its entirety.

TECHNICAL FIELD

[0002] The present disclosure relates to blood glucose determination in biological tissues. Specifically, this disclosure relates to systems, methods, and apparatuses for harmonizing data from a plurality of non-invasive sensors to estimate blood glucose levels.

BACKGROUND

[0003] Monitoring of blood glucose (blood sugar) concentration levels has long been critical to the treatment of diabetes in humans. Current blood glucose monitors involve a chemical reaction between blood serum and a test strip, requiring an invasive extraction of blood via a lancet or pinprick. Small handheld monitors have been developed to enable a patient to perform this procedure anywhere, at any time. But the inconvenience of this procedure—specifically the blood extraction and the use and disposition of test strips—has led to a low level of compliance. Such low compliance can lead to serious medical complications. Thus, a non-invasive method for monitoring blood glucose is needed.

SUMMARY

[0004] The present disclosure describes example systems, methods, apparatuses, and medical devices for harmonizing data from a plurality of non-invasive sensors. In general, a physiological parameter can be determined by harmonizing data between two or more different types of non-invasive physiological sensors interrogating the same or proximate measurement sites. In some cases, data from one or more first non-invasive sensors can be utilized to identify one or more variables that are useful in one or more calculations associated with data from one or more second non-invasive sensors. In some cases, data from one or more first non-invasive sensors can be utilized to calibrate one or more second non-invasive sensors. Non-invasive sensors can include, but are not limited to, an optical coherence tomography (OCT) sensor, a bio-impedance sensor, a tissue dielectric constant sensor, a plethysmography sensor, or a Raman spectrometer.

[0005] For purposes of summarizing the disclosure, certain aspects, advantages and novel features are discussed herein. It is to be understood that not necessarily all such aspects, advantages or features will be embodied in any particular embodiment of the invention and an artisan would recognize from the disclosure herein a myriad of combinations of such aspects, advantages or features.

BRIEF DESCRIPTION OF THE DRAWINGS

[0006] The following drawings and the associated descriptions are provided to illustrate embodiments of the present disclosure and do not limit the scope of the claims.

[0007] FIG. 1 illustrates an example patient monitoring system that includes a plurality of physiological sensors.

[0008] FIG. 2 illustrates a block diagram of an example patient monitoring system.

[0009] FIG. 3A illustrates an example 3D OCT image obtained from a volar side of forearm skin.

[0010] FIG. 3B illustrates an example one-dimensional distribution of light intensity versus depth graph obtained by averaging scans of the image of FIG. 3A.

[0011] FIG. 4 illustrates example micro-invasive elements of a bioimpedance sensor.

[0012] FIG. 5 illustrates an example bioimpedance sensor.

[0013] FIG. 6 shows a graph illustrating various example light intensity signals acquired at a patient’s wrist.

[0014] FIG. 7 illustrates a scaled view of the various example light intensity signals of FIG. 6.

[0015] FIG. 8 illustrates an approximation of an intensity of the fluorescence portion of the light intensity signals of FIG. 7.

[0016] FIG. 9 illustrates an approximation of an intensity of the isolated Raman with tissue absorption signals of FIG. 7.

[0017] FIG. 10 illustrates an approximation of an intensity of the isolated Raman with tissue absorption signals of FIG. 7.

[0018] FIGS. 11A-11C illustrate optical scattering differences in skin geometries among various age groups.

[0019] FIGS. 12A-12B illustrate an example sensor fusion apparatus configured with multiple sensing capabilities that interrogation of the same or a sufficiently proximate tissue site.

[0020] FIG. 13 illustrates an example reflectance sensor or probe.

[0021] FIG. 14 illustrates an environment that shows a hand of a user interacting with the example reflectance sensor of FIG. 13.

[0022] FIG. 15 illustrates an example physiological monitoring system.

[0023] FIGS. 16A-16C illustrate an example physiological monitoring apparatus.

[0024] FIG. 17 illustrates a flow diagram illustrative of an example routine for harmonizing data from a plurality of non-invasive sensors.

[0025] FIG. 18 illustrates a flow diagram illustrative of an example routine for harmonizing data from a plurality of non-invasive sensors.

[0026] While the foregoing “Brief Description of the Drawings” references generally various embodiments of the disclosure, an artisan will recognize from the disclosure herein that such embodiments are not mutually exclusive. Rather, the artisan would recognize a myriad of combinations of some or all of such embodiments.

DETAILED DESCRIPTION

[0027] Overview

[0028] Many non-invasive techniques for determining blood glucose have significant shortcomings, such as low accuracy (for example, less accuracy than invasive home monitors) and insufficient specificity of glucose concentra-

tion measurement. Accordingly, there is a need for an improved method to non-invasively monitor glucose. Systems and methods disclosed herein address various challenges related to non-invasively determining a patient's blood glucose level by harmonizing data from multiple non-invasive sensors. Each of the non-invasive sensors can interrogate the same or a similar tissue site of a patient, and variables identified using one or more sensors can be utilized to improve data from one or more other sensors. Using these data harmonization techniques, a glucose concentration measurement can be obtained.

[0029] In many instances, a single non-invasive sensor may lack the functionality to measure each of the parameters required for an accurate determination of an analyte concentration. As a result, many physiological monitoring techniques include estimations, such as those based on common assumptions, to compensate for the lack of known data. However, due to the sensitivity of analyte measurements, these estimations can result in inaccurate or unreliable determinations.

[0030] For example, Beer's Law (also known as the Beer-Lambert Law) relates the attenuation of light to properties of a material. In particular, Beer's law states that absorbance of a material is proportional to the concentrations of the attenuating species in the material sample. The relationship between these parameters is expressed in Equation 1 below:

$$A = \epsilon * b * c \quad (\text{Equation 1})$$

where A is the absorbance of the material at a given wavelength of light, ϵ is the molar absorptivity or extinction coefficient ($\text{L mol}^{-1} \text{cm}^{-1}$), unique to each molecule and varying with wavelength, b is the length of the light path through the material (cm), and c is the concentration of an analyte of interest (mol L^{-1}).

[0031] In many cases, the length of the light path through the material (sometimes referred to as the path length) is estimated. For example, a generic finger may be associated with a first estimated path length value, while a generic nose may be associated with a second path length value. However, every person has a unique tissue geometry, which can include, but is not limited to, unique skin structure or skin thickness. Furthermore, because tissue is not uniform throughout a person's body, even tissue sites that are close in proximity, such as two different measurements sites on a patient's finger, can have a different tissue geometry. As noted above, a specific tissue geometry of a particular tissue site can affect the path length value. Accordingly, a non-invasive physiological sensor can be configured to obtain skin geometry data, which can be utilized to calculate a path length associated with a tissue site. In addition or alternatively, the skin geometry data can be utilized to calibrate one or more sensors (for example, select a focal depth of Raman spectrometer), which can result in more accurate analytes measurements, such as blood glucose concentration measurements.

[0032] An optical coherence tomography, or OCT, sensor can be utilized to obtain tissue geometry information. OCT is an optical imaging technique using light waves that produce high-resolution imagery of biological tissue. OCT creates its images by interferometrically scanning in depth a linear succession of spots, and measuring backscattered light at different depths in each successive spot. The OCT data can be processed to present an image of the linear cross section. OCT data can be processed to determine tissue

geometry information, such as skin geometry. For example, the OCT data can provide data regarding a thickness of one or more skin layers, such as the epidermis, the dermoepidermal junction, or the dermis.

[0033] In addition or alternatively, OCT data can be utilized to determine whether successive OCT measurements have occurred in the same or a different location. For example, one reason data harmonization between sensors is available relates to the specific optical profile of a particular tissue site. That is, a particular tissue site retains its specific optical profile, and a different measurement location may have a different optical profile. Thus, in many cases, to maintain data harmonization capabilities, each of the sensors should interrogate the same or a substantially proximate tissue site. One problem associated with interrogating the same or a substantially proximate tissue site relates to the subsequent placement of a sensor after it has been removed from the patient. To solve these and other problems, tissue geometry information associated with OCT data can be utilized to determine whether a later one of successive OCT measurements is taken at the same tissue site as a previous one of the successive OCT measurements.

[0034] A bio-impedance or tissue dielectric constant sensor can be utilized to obtain tissue geometry information. For example, bio-impedance or tissue dielectric constant data can provide information relating to one or more skin layers, a hydration of one or more skin layers, or a cellular structure of the tissue.

[0035] Raman spectroscopy has exhibited promise with respect to blood glucose detection, for example, due to its capability to gain information about the molecular constitution non-invasively. For example, features such as peaks of the Raman spectra are considered the Raman "fingerprints" of analytes such as glucose. Accordingly, using an isolated or semi-isolated Raman signal, the system can identify physiological data, such as information regarding a patient's blood glucose level.

[0036] For various reasons, it has been challenging to isolate a pure Raman signal from a signal obtained from a Raman spectrometer. For example, emission of fluorescence in tissue often overwhelms any signal collected from the Raman spectrometer, thereby hiding Raman features. In addition, attenuation of the signal due to absorption can further affect prediction of analytes using the collected signal. Furthermore, varying tissue geometries at tissue sites increases a difficulty in selecting a focal depth of the Raman spectrometer that will optimize a resolution of the Raman signal.

[0037] Systems and methods disclosed herein address one or more of these or other challenges by utilizing data associated with one or more sensors to calibrate or improve an accuracy of one or more other sensors. For example, a value for path length can be obtained from skin geometry data, which can improve a pulse oximetry sensor such as a near infrared (NIR), reflectance, or transmittance sensor. As another example, the present disclosure addresses various challenges related to leveraging the Raman scattering signatures for prediction of glucose by harmonizing data from a plurality of non-invasive physiological sensors. For instance, a focal depth of the Raman spectrometer can be selected based on tissue geometry data, which can improve the Raman spectrometer, and possibly increase an accuracy of a blood glucose measurement. Similarly, using data from one or more sensor, the Raman signal can be isolated by

reducing or removing an effect of Fluorescence on a collected signal, or removing an effect of attenuation of the signal due to absorption.

System Overview

[0038] FIG. 1 illustrates an example patient monitoring system 100 that includes a patient monitor 102, a first sensor 104A, and a second sensor 104B. In addition, the patient monitoring system 100 can include one or more other sensors 104N. Sensors 104A, 104B, and 104N can interrogate tissue sites 106A, 106B, and 106N, respectively, of a patient. In some cases, tissue sites 106A, 106B, and 106N can be the same or substantially proximate tissue sites, while in other cases one or more of the tissue sites 106A, 106B, or 106N can be different. Sensor data from the sensors 104A, 104B, or 104N can be utilized to determine one or more physiological parameters or patient vitals. For example, the patient monitor 102 can receive a signal from the one or more of the sensors 104A, 104B, or 104N and can determine, based on the received signal(s), one or more physiological parameters or one or more measurements that can be used to determine a physiological parameter.

[0039] The sensors 104A, 104B, and 104N can each be the same type of sensors, or one or more of the sensors 104A, 104B, and 104N can be different from each other. For example, the sensors 104A, 104B, and 104N can include, but are not limited to, any combination of an optical coherence tomography (OCT) device, a spectrometer (for example, a Raman spectrometer), a plethysmograph sensor such as a pulse oximetry device (for example, a near infrared (NIR), reflectance and/or transmittance device), a pressure sensor, an electrocardiogram sensor, a bioimpedance sensor, or acoustic sensor, among other sensors.

[0040] Two or more of the sensors 104A, 104B, or 104N can be configured to interrogate the same tissue site. For example, two or more of the sensor sensors 104A, 104B, or 104N can be positioned proximate each other such that they can interrogate the same tissue, such as a finger, a thumb, a thenar space, a hand, a wrist, a forearm, a nose, a limb, a head, an ear, a neck, an upper body, or a lower body. In addition or alternatively, two or more of the sensors 104A, 104B, or 104N can be configured to interrogate different tissue sites.

[0041] In some cases, one or more of the sensors 104A, 104B, or 104N can be integrated into an apparatus, such as an apparatus that is wearable by a user. For example, one or more of the sensors 104A, 104B, or 104N can be integrated into a glove that when worn by a user allows the sensor(s) to interrogate one or more tissue sites. Similarly, one or more of the sensors 104A, 104B, or 104N can be incorporated in or attached to various other apparatuses, including, but not limited to, a sock, a shirt, a sleeve, a cuff, a bracelet, a glove, or the like.

[0042] In some cases, data from a single sensor 104A, 104B, or 104N does not provide enough reliable information to determine certain physiological parameters. For example, a number of factors can affect an accuracy of sensor data including, but not limited to, patient movement, sensor placement, interference, the type of sensor being used, the expansion and contraction of the patient's vascular system, assumptions made during calculations, skin temperature, pressure, or the like. In addition or alternatively, the deter-

mination of some physiological parameters (for example, glucose concentration) may require more information than a single sensor can provide.

[0043] To solve this and other problems, the patient monitor 102 (or one or more of the sensors) can harmonize or compare data from two or more sensors, which can allow for a determination of more accurate or reliable data, or can allow for a determination of one or more additional physiological parameters, such as blood glucose concentration.

[0044] As one example, the patient monitor 102 receives a first signal from a first sensor 104A, the first signal corresponding to an interrogation of the first tissue site 106A by the first sensor 104A. Further, the patient monitor 102 receives a second signal from a second sensor 104B, the second signal corresponding to an interrogation of the second tissue site 106B by the second sensor 104B. Based on the first signal, the patient monitor 102 can make adjustments to modify the second sensor or the second measurement to improve the accuracy or reliability of the second sensor or the second measurement. For instance, adjustments can include, but are not limited to, adjusting an intensity, power, position, or timing of the second sensor 104b or adjusting values corresponding to the measurement of the second physiological parameter. For example, the patient monitor 102 can modify the second measurement or calculations for a physiological parameter (for example, introduce an offset, adjust assumed or estimated values, filter a signal, etc.) to account for information from the first sensor. In addition or alternatively, the patient monitor can adjust a confidence value associated with the first, second, or another measurement.

[0045] As described above, based at least in part on the first and second signals, the patient monitor 102 can determine a physiological parameter. The physiological parameter can be a value which may not be independently determinable from data from either of the first sensor or the second sensor alone. For example, data from the first sensor can be utilized to determine a path length, data from the second sensor can be utilized to determine an absorbance, and the physiological parameter can include a concentration of an analyte, such as glucose. As another example, data from the first sensor can be utilized to determine a path length or absorbance, the second sensor can correspond to a Raman spectrometer, and the physiological parameter can include a concentration of an analyte, such as glucose.

[0046] The patient monitor 102 can include a digital signal processor (DSP) that receives the signals generated by the one or more sensors 104A, 104B, or 104N (for example, through a front-end unit) and determines parameters, for example, those indicative of the physiological condition of the patient, using the received signals. The patient monitor 102 can, for example, determine physiological parameters corresponding to the patient, such as an amount of light absorbed, transmitted through, or reflected at a tissue site, path length (for example, distance that light travels through the material), concentration of an analyte, bioimpedance, tissue dielectric constant, pulse rate (PR), pulse pressure variation (PPV), pleth variability index (PVI®), stroke volume (SV), stroke volume variation (SVV), peripheral capillary oxygen saturation (SpO₂), mean arterial pressure (MAP), central venous pressure (CVP), pulse pressure (PP), perfusion index (PI), total hemoglobin (SpHb®), carboxyhemoglobin (SpCO®), methemoglobin (SpMet®), oxygen content (SpOC®), or acoustic respiration rate (RRa®),

among other parameters. In some aspects, the patient monitor **102** can derive or use one or more relationships (for instance, a set of linear equations) from two or more of the determined parameters. The patient monitor **102** can utilize the one or more relationships to determine the patient's glucose levels, systemic vascular resistance (SVR), CO, or arterial blood pressure (BP), among other parameters.

[0047] The patient monitor **102** can further compare or analyze one or more of the determined parameters (for instance, at least two of the determined parameters or one determined parameter and a previous or model parameter) to adjust how a parameter is measured or calculated to make the measured parameter more accurate or reliable, to adjust a sensor to make the measured parameter more accurate or reliable, to calculate, derive or determine an accuracy or a confidence value of a measured parameter, to isolate a parameter, or to determine another parameter based on the one or more parameters. The sensors, in addition to or alternatively than the patient monitor, can coordinate with each other to coordinate data or adjust calculations to enhance an accuracy or reliability of measurements. In addition or alternatively, the patient monitor **102** can use the data to increase an accuracy of one or more calculations, calculate a previously unknown or estimated physiological parameter, calibrate data, or compensate for various circumstances that might otherwise result in inaccurate or unreliable data.

Additional Implementations

[0048] The patient monitor **102** can be connected to one or more (for instance, three, four, five, or six) sensors, such as the sensors **104A**, **104B**, or **104N**, that are detecting from a patient and use the signals received from the sensors to determine one or more physiological parameters including, but not limited to, glucose, SpO₂, PPR, PVI® (for instance, via a palm, thumb or finger plethysmography sensor), SV, MAP, CVP, PP, or PI (for instance, via a palm, thumb or finger plethysmography sensor), among other parameters such as those described herein.

[0049] Moreover, the patient monitor **102** can utilize any of the techniques described herein to determine whether any measurement described herein (using any of the sensors described herein) is valid. The patient monitor **102** can be configured to show (for example, on a display) information about a valid or invalid measurement, activate an indicator light (such as an LED), trigger an alarm, adjust one or more sensors or parameters (for instance, based on a received sensor signal), or display any data.

[0050] The patient monitor **102** can wirelessly or using wires receive, via an input of the patient monitor **102**, a signal from one of the sensors **104A**, **104B**, or **104N**. The received signal may take various forms, such as a voltage, a current, or charge. An operational amplifier (op-amp) of the patient monitor **102** can increase the amplitude, as well as transform the signal, such as from a current to a voltage. An anti-aliasing filter (AAF) of the patient monitor **102** can then process of the output signal from the op-amp to restrict a bandwidth of the output signal from the op-amp to approximately or completely satisfy the sampling theorem over a band of interest. An analog-to-digital convertor (ADC) of the patient monitor **102** can convert the output signal from the AAF from analog to digital. The output signal from the ADC can then be sampled by a first processor of the patient monitor **102** at a relatively high speed. The result of the

sampling can next be downsampled by a second processor of the patient monitor **102**, which may be the same or different from the first processor, before waveform analysis may be performed by a DSP.

[0051] FIG. 2 illustrates a block diagram of an example patient monitoring system **200**, which can be an embodiment of the patient monitoring system **100**. The patient monitoring system **200** can include a patient monitor **202**, a first non-invasive physiological sensor **204A**, a second non-invasive physiological sensor **204B**, or a third non-invasive physiological sensor **204C**. Furthermore, it should be noted that fewer, additional, or different sensors may be included in patient monitoring system **200**.

[0052] The sensors **204A**, **204B**, or **204C** can respectively detect from tissue sites **206A**, **206B**, and **206C** of a patient. Each of the sensor can measure from the same or a similar tissue site. For example, sensor **204A** can take a measurement and sensor **204B** can take a subsequent measurement on the same tissue or at the same location. This may allow the system to more easily harmonize the data from the sensors or use data from one sensor to improve data or calculation based on another sensor. The tissue sites **206A**, **206B**, and **206C** can be different. As a non-limiting example, tissue site **206A** can include a thenar space of a patient's hand, and tissue sites **206B**, **206C** include a thumb of the patient, such as a base of the thumb. It should be noted, however, that fewer, more or different sensors can be include in system **200**.

[0053] The DSP **212A** can communicate via drivers **216A** with the plethysmography sensor **204A** and receive via a front-end **214A** one or more light intensity signals indicative of one or more physiological parameters of the patient or one or more measurements that can be used to determine one or more physiological parameters. For example, a signal can be indicative of an intensity of light reflected, refracted, scattered, absorbed, or transmitted at a tissue site. The drivers **216A** can convert digital control signals into analog drive signals capable of driving emitters **209A** to illuminate the tissue site **206A**. For example, the light emitted by emitters **209A** can have an infrared (IR), near infrared (NIR), red, ultra-violet (UV), visible, or other wavelength. The detector (s) **208A** can, in turn, generate one or more composite analog light intensity signals responsive to light detected by the detector(s) **208A** after attenuation, reflection, refraction, scattering, absorption, etc. at the tissue site **206A**. The emitter(s) **209A** or detector(s) **208A** include a fiber-optic component for illumination and collection, respectively. For example, the emitter(s) **209A** can be positioned on a tissue site **206A** (for example, on top, on the bottom, on the side, etc.) and the detector(s) **208A** can be positioned on an opposite portion of the tissue site **206A**.

[0054] The front-end **214A** can convert the one or more composite analog light intensity signals from the detector(s) **208A** into digital data and input the digital data into the DSP **212A**. The digital data from the front-end **216A** can correspond to at least one of a plurality of physiological parameters as described herein. For example, the digital data from the front-end **216A** can be representative of a change in the absorption of particular wavelengths of light as a function of the changes in the tissue site **206A** resulting from pulsing blood.

[0055] The DSP **212A** can include one or more data or signal processors configured to execute one or more programs for determining physiological parameters from input

data. The DSP 212A can perform operations that include calculating or outputting one or more physiological measures, such as absorbance, path length, PVI® and other parameters described herein. The operations performed by the DSP 212A can be implemented in software, firmware or other form of code or instructions, or logic or other hardware, or a combination of the above.

[0056] The instrument manager 210 can communicate with one or more input or output devices 220. The one or more input or output devices 220 can include a user interface 222, controls 224, a transceiver 226, and a memory device 228.

[0057] The user interface 222 can include a numerical or graphical display that provides readouts of measures or parameters, trends and bar graphs of measures or parameters, visual indications of measures or parameters, visual indicators like LEDs of various colors that signify measurement magnitude, or device management interfaces, which can be generated by LEDs, LCDs, or CRTs, for example. The user interface 222 can include an audible output device that provides readouts or audible indications of measures or parameters. The user interface 222 can include one or more input devices like a keypad, touch screen, pointing device, voice recognition device, and computer that can be used to supply control or configuration data, such as initialization settings, from the user interface 222 to the instrument manager 210. In some implementations, the user interface 222 can be an interface for devices as well as users.

[0058] The controls 224 can be outputs to medical equipment, such as drug administration devices, ventilators, or fluid IVs, so as to control the amount of administered drugs, ventilator settings, or the amount of infused fluids. The patient monitor 202 can use the controls 224 to automatically treat the patient (for instance, provide fluid to the patient, provide medication to the patient, turn on a fan to cool the patient, or adjust a temperature of a room to heat or cool the patient) in response to determining that the patient may benefit from treatment.

[0059] The transceiver 226 via an antenna can transmit information about operation of the patient monitor 202 to an electronic device or receive control or configuration data for operating the patient monitor 202. The transceiver can, for example, communicate via a computer network or intermediary device or directly with the electronic device using electromagnetic radiation.

[0060] The memory device 228 can be used to store information about operation of the patient monitor 202. This information can, for example, include readouts of measures or parameters, trends and bar graphs of measures or parameters, visual indications or indicators.

[0061] The DSP 212B can receive via a front-end 214B one or more light intensity signals indicative of one or more physiological parameters of the patient. The drivers 216B can convert digital control signals into analog drive signals capable of driving emitters/detectors 220 to illuminate the tissue site 206B. For example, the light emitted by emitters/detectors 220 can be infrared (IR), near infrared (NIR), red, ultra-violet (UV), visible, or other wavelength. The emitters/detectors 220 can, in turn, generate one or more composite analog light intensity signals responsive to light detected by the emitters/detectors 220 light is reflected, refracted, scattered, absorbed, or attenuated at a tissue site 206B. The emitters/detectors 220 include a fiber-optic bundle that has

illumination and detection fibers. In addition, for example, as described with respect to FIG. 1, the emitters/detectors 220 can be separate.

[0062] The front-end 214B can convert the one or more composite analog light intensity signals from the emitters/detectors 220 into digital data and input the digital data into the DSP 212B. The digital data from the front-end 214B can correspond to at least one of a plurality of physiological parameters, as described herein. The digital data from the front-end 214B can be representative of a change in the absorption/reflection of particular wavelengths of light as a function of the changes in the tissue site 206B resulting from pulsing blood.

[0063] The DSP 212B can include one or more data or signal processors configured to execute one or more programs for determining physiological parameters from input data. The operations performed by the DSP 212B can be implemented in software, firmware or other form of code or instructions, or logic or other hardware, or a combination of the above.

[0064] Sensor 204C includes a detector 208C, a light source 209C, a beam splitter 224C, and a reflector 222C. The light source 209C can emit light having an approximately equal wavelength, a spectrum of wavelengths, or a few different wavelengths, for example, two. For example, the wavelengths can be selected based on the absorption spectrum.

[0065] As illustrated, light beams from the light source 209C are split using the beam splitter 224C into reference arm light beams 230 and sample arm light beams 228. After the light beams 234 are split, the reference arm light beams 230 travel down the reference arm to interact with the reflector 222C, and the sample arm light beams 228 travel down the sample arm to interact with the tissue 206C, for example, from the base of a patient's thumb.

[0066] The tissue site 206C can absorb, reflect, scatter, or refract the sample arm light beams 228. Some of the sample arm light beams 228 are reflected back to the beam splitter 224C. The beam splitter 224C can direct at least some of the reflected sample arm light beams 228 to the detector 208C.

[0067] The light beams traveling down the reference arm interact with a reflector 222C and are reflected back to the beam splitter 224C. Similar to the reflected sample arm light beams 228, the reflected reference arm light beams 230 are also directed to the detector 208C by the beam splitter 224C. Reflected signals from the sample arm and reference arm and are presented to photodetector 208C for measurement.

[0068] The tissue volume with which the light interacts (referred to as the interaction volume) can be determined by the spot size of the imaging optics (surface area) and the coherence length of the light (depth). Thus, the reference arm can determine the depth within the interaction volume from which scattered light is measured. The patient monitor 200 uses the detected signals obtained from the interference of the reflected sample arm light beams 228 and the reflected reference arm light beams 230 to calculate tissue geometry data, such as a skin geometry of one or more skin layers.

[0069] Although not illustrated in FIG. 2, imaging optics can also be used to focus the sample arm light beams 228 prior to interacting with the tissue site 206C. Furthermore, the end of the sample arm and imaging optics can be placed in close proximity to the tissue site 206C. The reference arm and reflector 222 are configured such that appropriate wave-

length and polarization selected such that the appropriate depth of the tissue is measured.

[0070] The DSP 212C can receive via a front-end 214C one or more signals indicative of one or more physiological parameters of the patient, such as path length. The drivers 216C can convert digital control signals into analog drive signals capable of driving emitters 209C to illuminate the tissue site 206C. The detectors 208C can, in turn, generate one or more composite analog signals responsive to light detected by the detectors 208C.

[0071] The front-end 214C can convert the one or more composite analog signals from the detectors 208C into digital data and input the digital data into the DSP 212C. The digital data from the front-end 216C can correspond to at least one of a plurality of physiological parameters, as described herein. The DSP 212C can include one or more data or signal processors configured to execute one or more programs for determining physiological parameters from input data. The operations performed by the DSP 212C can be implemented in software, firmware or other form of code or instructions, or logic or other hardware, or a combination of the above.

[0072] One or more of the components relating to signal acquisition or processing (for example, front end 214A, 214B, 214C, drivers 216A, 216B, 216C, DSP 212A, 212B, 212C, etc.) can be incorporated into one or more connecting cables, the sensors themselves, or are otherwise closer to the sensor sites. As such, the patient monitor 202 can include primarily the input or output devices 220 and the instrument manager 210, (if appropriate). In addition, some of the components are illustrated as separate units but can be combined. For instance, front end 214A, 214B, 214C can be combined into one or more front ends, drivers 216A, 216B, 216C, can be combined into one or more drives, DSP 212A, 212B, 212C can be combined into one or more DSPs, etc. By reducing the number of components included in the patient monitor 102, 202, the monitor can be smaller in size or more portable, which can be more convenient for home or "spot check" use.

[0073] Although not illustrated in FIG. 1 or 2 patient monitors 102, 202, or cables connecting the patient monitors to the sensors can further include one or more outputs that supply the signal(s) from one or more of the sensors to one or more other electronic devices for further processing. As one example, the signal(s) from one or more of the sensors can be output in parallel by one or more of the sensors or the cables that couple the one or more sensors to the patient monitor 102, 202. In another example, the patient monitors 102, 202 can include one or more outputs for outputting copy(ies) of the signal(s) from one or more of the sensors. The copy(ies) of the signal(s) can also be adjusted relative to the original(s) with filtering, scaling, or other changing prior to being provided to the one or more other electric devices.

Optical Coherence Tomography

[0074] Optical coherence tomography, or OCT, is an optical imaging technique using light waves that produces high-resolution imagery of biological tissue. OCT creates its images by focusing a beam of light into a medium and interferometrically scanning the depth of a linear succession of spots and measuring the absorption and/or the scattering of the light at different depths in each successive spot. In

some cases, the data can be processed to present an image of the linear cross section of the medium scanned.

[0075] A light source can output a beam of light having a broad spectrum of wavelengths. The beam of light can be collimated and pass a beam splitter such that a portion of the beam of light is directed towards the tissue and a portion of the beam of light is directed toward a reference arm. The light can be either polarized or non-polarized. A polarizer located on one edge of the beam splitter can polarize the light linearly, elliptically, or circularly, as desired. The path length of the reference arm can be changed based on the desired measurement depth into the tissue. The wavelength can be centered at, for example, 1310 nm with a 50 nm bandwidth. In other cases, the wavelength can be 1060 nm with a 70 nm bandwidth. The light source can be selected to have a center wavelength anywhere between 400 nm and 1700 nm with a bandwidth of up to 150 nm. It is understood that different light sources with different bandwidths can be chosen to optimize penetration depth into the tissue and optimize the depth resolution of sensitivity to skin structures. The reflected light from the tissue can be collected using a converging lens and be directed back through the beam splitter to a photodetector where it is recombined with a portion of the reference arm beam to form an interference pattern. A processor can use the signals from the photodetector to render an image of the tissue.

[0076] OCT can provide a non-invasive method for identifying one or more characteristics of a tissue's structure. For example, OCT data (which can be referred to as tissue geometry data) can include an indication of a boundary between the main skin layers, such as the epidermis (outermost layer of the skin), the dermis (layer beneath the epidermis), or the hypodermis (layer directly below the dermis and serves to connect the skin to the underlying fibrous tissue of the bones or muscles). The epidermis is further divided into five, separate layers (Stratum Corneum, Stratum Lucidum, Stratum *Granulosum*, Stratum *Spinosum*, and Stratum Basale) and the dermis is divided into two, separate layers (the papillary dermis and the reticular dermis). In some cases, OCT data can provide an indication of a boundary between any of these layers. In addition or alternatively, OCT data can include an indication of a thickness of any of the epidermis, dermis, or hypodermis, or their individual layers.

[0077] For example, FIG. 3A illustrates an example 3D OCT image obtained from a volar side of forearm skin, and FIG. 3B illustrates an example one-dimensional distribution of light intensity vs. depth obtained by averaging Amplitude scans (A-scans) in the reconstructed OCT 3D image of FIG. 3A. The slope of the line of FIG. 3B is indicative of index of refraction of tissue. A difference in the index of refraction, or a difference in slope, can indicate a new skin or tissue layer because each layer may have a different index of refraction. As illustrated, the first peak 302 corresponds to the skin surface 302, and the second peak 308 corresponds to the dermoepidermal junction, which is the area of tissue that joins the epidermis 310 and the dermis layers (for example, the papillary dermis 304) of the skin. Accordingly, using OCT data, the system 200 can determine a thickness of one or more of various skin layers such as, but not limited to, the epidermis 310, the dermoepidermal junction, the papillary dermis 304, the reticular dermis 306, or the like.

[0078] In some cases, OCT data can provide an indication that an OCT sensor is interrogating an unfavorable tissue

site. An unfavorable tissue site can include any tissue site that might provide distorted or inaccurate OCT data (relative to desired OCT data), such as tissue sites that include at least a portion of a hair follicle, a pore, a bone, a finger- or toe-nail, a pimple, a mole, a scar, a blister, a callous, debris, other skin imperfection, or the like.

[0079] A particular tissue site can retain its specific optical profile over time, and that optical profile can be different from another tissue site. Accordingly, to maintain data harmonization capabilities, it can be advantageous for sensors to interrogate the same or a substantially proximate tissue site. One problem associated with interrogating the same or a substantially proximate tissue site relates to the subsequent placement of a sensor after it has been removed from the patient or when it is shifted in some way from its original positioning. For example, a subsequent OCT measurement or set of measurements can occur minutes, hours, days, weeks, or some other period of time after the first measurement, and it can be unreasonable to require a patient to wear or interact with the OCT sensor for the duration of that period of time. Nonetheless, even though the OCT sensor has been separated from the patient or shifted from its original position, it can be advantageous for the subsequent OCT measurement(s) to occur at the same location as the first measurement. For example, as described herein, a first tissue site may have a different tissue structure, density, depth, hydration, analyte concentration, or the like than a second, different tissue site. Thus, if the OCT sensor is placed at the same location for each measurement, then previous calculations, determinations, or the like can be utilized, which can simplify any calibrations or corrections to sensor data, among other things.

[0080] To solve these and other problems, tissue geometry information associated with OCT data can be utilized to determine whether a subsequent placement of the OCT sensor allows the OCT sensor to interrogate the tissue site corresponding to the tissue site of the first OCT measurement(s). For example, a processor can compare the first tissue geometry data associated with the first OCT measurement(s) with the subsequent tissue geometry data associated with the subsequent OCT measurement(s). If the subsequent tissue geometry data does not correspond to the first tissue geometry data, then the processor can cause one or more actions to occur. For example, the processor can cause an output to indicate that the subsequent tissue geometry data does not correspond to the first tissue geometry data. In other words, the processor can cause an output to indicate that the subsequent placement of the OCT sensor is incorrect, or is different from the first OCT sensor placement, or the processor can cause an output to indicate a probe-off condition. In addition or alternatively, the processor can cause the OCT sensor to be re-positioned. For example, based on the comparison, the processor can suggest a new placement of the OCT sensor, which may more closely correspond to the first placement of the OCT sensor. In addition or alternatively, the processor can control a motorized component to re-position to the OCT sensor such that it more closely corresponds to the first placement of the OCT sensor. Still, in some implementations, the processor can calibrate other sensors based on the subsequent tissue geometry data, rather than the first tissue geometry data.

[0081] Alternatively, if the subsequent tissue geometry data does correspond to the first tissue geometry data, then the processor can cause one or more other actions to occur.

For example, the processor can cause an output to indicate that the subsequent tissue geometry data does correspond to the first tissue geometry data. In other words, the processor can cause an output to indicate that the subsequent placement of the OCT sensor is correct, as compared to the first placement of the OCT sensor. In addition or alternatively, the processor can calibrate other sensors based on the first tissue geometry data or the subsequent tissue geometry data.

Bioelectrical Impedance (Bioimpedance)

[0082] Impedance can be characterized as a physical variable describing the resistance characteristics acting on an electric current. Bioelectrical impedance is based on the principle that tissues or fluids of a patient have different impedances, that is, opposition to the flow of the electric current, which in turn may be dependent on variables such as water and electrolyte content, to name a few. Using a bioelectrical impedance, analysis can be performed to examine electrical, capacitive, or resistive characteristics of tissue to provide information on a noninvasive basis.

[0083] Mathematically, bioelectrical impedance can be represented as a complex number including a real component (resistance) and an imaginary dimension (reactance). For example, the bioelectrical impedance can be calculated using the following equation below:

$$Z=R+jX=|Z|e^{j\theta} \quad (\text{Equation 2})$$

where R is resistance, X is reactance, |Z| is amplitude, and θ is phase.

[0084] A number of physiological characteristics or parameters can be calculated or estimated using determined bioelectrical impedance characteristics, such as water content, body cell mass (BCM), extra cellular mass (ECM), extracellular fluid (ECF), extracellular water (ECW), fat-free mass (FFM), fat mass (FM), total body water (TBW), electrolyte composition, cell membrane mass, cell membrane function and the like.

[0085] Biological tissues can have complex electrical impedance which is dependent, for instance, on the frequency of the electrical applied field or tissue cellular structure. Therefore, the electrical impedance of tissue is a function of its structure and it can be used to differentiate or determine characteristics of one or more layers to tissue.

[0086] The system can include a bioimpedance sensor configured to apply an electrical signal to the tissue, which can include one or more of various voltages, currents, frequencies (for example, 1 kHz to 2.5 GHz), or fields. In some cases, the path length of the signal can vary based on the applied electrical signal. For example, low frequency signals may primarily reflect the extracellular environment, while high frequency signals may reflect both the intra- and extracellular environment. In addition, the bioimpedance sensor can be configured to measure characteristics of the applied electrical signal as it passes (or after it has passed) through tissue. For example, the bioimpedance sensor can measure a voltage, current, frequency, magnetic field, etc., which can be indicative of a voltage difference across tissue or a biological impedance of a tissue, to name a few.

[0087] One or more properties of skin may disturb or disrupt bioimpedance measurements. For example, the stratum corneum can limit bioimpedance measurements. Accordingly, as illustrated in FIG. 4, the bioimpedance sensor can include a micro-invasive element 402 that is configured to penetrate the stratum corneum layer. For

example, the bioimpedance sensor can include spikes or other elements that penetrate approximately 10-20 μm deep.

[0088] FIG. 5 illustrates an example bioimpedance sensor 502. The sensor 502 can include multiple channels of spiked regions configured to penetrate the skin. As shown, spacing between the channels can allow for shallow and deep penetration, such that the bioimpedance sensor 502 can measure impedance at various depths, such as Depths 1a, 2a, 2b, 3a, or 4a.

[0089] Using information from the bioelectric sensor(s) 502, the system 200 can determine information about the tissue geometry. For example, based on bioelectric sensor data, the system can determine a cellular structure of the tissue, which may affect various physiological parameters, such as path length or absorption. In addition, based on bioelectric sensor data, the system can determine information related to hydration of the skin or tissue. For example, water content can be directly related to skin thickness. As described herein, in some cases, the system can select a focal depth of the Raman spectrometer based at least in part on tissue geometry data.

Tissue Dielectric Constant

[0090] In addition or alternatively to bioimpedance or OCT, the system can utilize one or more tissue dielectric constant sensors to determine various tissue geometries or tissue information, including, but not limited to a dielectric constant of tissue. For example, the system 200 can include a plurality of probes for different measuring depths, such as 0.5 mm, 1.5 mm, 2.5 mm, and 5 mm effective depths, and the system can determine a dielectric value at each of the different depths. In addition or alternatively, the system 200 can include one or more probes that are each configured to measure at different depths, such as 0.5 mm, 1.5 mm, 2.5 mm, and 5 mm effective depths, and the system can determine a dielectric value at each of the different depths. The dielectric value can correlate with water content, which can be tied to tissue structure.

[0091] Accordingly, the tissue dielectric constant can provide information which can be combined with other sensor information (for example, OCT, bioimpedance, reflectance or transmission measurements, Raman measurements) to determine more accurate physiological measurements, such as blood glucose levels. For example, the bioimpedance or tissue dielectric constant data can provide information that correlates with local tissue hydration, or can provide information about different skin layers or cellular structure information. Furthermore, bioimpedance or tissue dielectric constant sensors can provide real-time measurements that can provide information about physiological “noise” within the tissue, which can be used to calibrate other measurements or calculations. As described herein, in some cases, the system can select a focal depth of the Raman spectrometer based at least in part on tissue geometry data.

Raman Spectroscopy

[0092] The Raman effect is a light-scattering phenomenon that can provide insight as to one or more characteristics of an analyte in a sample. When light irradiates a tissue, a fraction of the light is scattered, meaning it emerges in directions other than that of the incident (incoming) beam. Most of this scattered light, generally referred to as Rayleigh scattering, emerges at the original frequency (f_0) and wave-

length of the incident beam. A small portion of the scattered light, however, emerges at some shifted frequency (f_s) that is different from, and usually lower than, the original frequency (f_0) and has wavelengths different from that of the incident light. The process leading to this small portion of the scattered light is termed the Raman effect or Raman scattering.

[0093] Raman scattering can occur with a change in vibrational or rotational energy of a molecule. Accordingly, the Raman spectra can contain information about the specific chemical substance in the irradiated tissue. For example, Raman scattering yields a set of characteristic peaks in a spectrum, which is a “fingerprint” of a specific chemical substance. Therefore, Raman has high specificity in glucose measurements.

[0094] Raman spectroscopy has exhibited promise with respect to blood glucose detection, for example, due to its capability to gain information about the molecular constitution non-invasively. For example, features (such as peaks) of the Raman spectra are considered the Raman “fingerprints” of analytes, such as glucose. Accordingly, using an isolated or semi-isolated Raman signal, the system can identify physiological data, such as information regarding a patient’s blood glucose level. However, for various reasons, it has been challenging to isolate a pure Raman signal from a signal obtained from a Raman spectrometer.

[0095] The signal collected through Raman spectroscopy is based at least in part on the collection optics and the focal distance/depth of the optics into the tissue. In some cases, the system can use data from one or more sensors to select an appropriate focal depth. For example, a focal depth can be selected that may provide a high or the highest resolution of the Raman or collected signal. In addition or alternatively, a focal depth can be selected that will allow the Raman spectrometer to focus on a particular location of the tissue, such as the capillary beds. For example, OCT, bioelectrical impedance, or tissue dielectric constant measurements may provide tissue geometry data (for example, structural and functional information) that can be used to select a focal depth into the tissue. For example, the selection can be based at least in part on a water content of a portion of the tissue, a thickness of one or more skin layers, or a particular location of tissue, such as the capillary beds.

[0096] Although complex, an approximation of a measurement obtained from a Raman spectrometer can be determined using one or more of the following equations:

$$I_1 = I_0 e^{-A_1} \quad (\text{Equation 3})$$

$$R_0 = R_A I_1 \quad (\text{Equation 4})$$

$$F_0 = \Phi I_1 \quad (\text{Equation 5})$$

$$I_2 = \Sigma((R_0 + F_0) e^{-A_2}) \quad (\text{Equation 6})$$

where I_0 is an intensity of excitation light, I_1 is an intensity of scattered light, A_1 is a first interrogation volume, R_A represents Raman activity, R_0 is an intensity Raman scattering at a specific wavelength of light, F_0 is an intensity of Fluorescence at the specific wavelength of light, Φ represents quantum efficiency, A_2 represents a second interrogation volume, and I_2 is an intensity of measured light. From these relationships, it can be seen that the intensity of measured light (I_2) is dependent on the intensity of Raman scattering (R_0), the intensity of Fluorescence (F_0), or the second interrogation volume (A_2), among other things. Due to the

nature of the Raman spectroscopy, the intensity of Raman scattering (R_0) is often of very low intensity. In various aspects, the system can reduce or remove an effect of Fluorescence or absorption on the measured signal, thereby isolating or improving the Raman signal (R_0).

Fluorescence

[0097] A challenge in the implementation of Raman spectroscopy to obtain physiological data is the emission of fluorescence. Accordingly, if fluorescence is generated, it often overwhelms the Raman signal, effectively hiding the Raman features. Thus, in some cases, it can be advantageous to isolate the Raman signal.

[0098] FIG. 6 shows a graph 600 illustrating various example light intensity signals acquired at a patient's wrist. In this example, the y-axis corresponds to arbitrary intensity units, while the x-axis corresponds to a wavenumber shift (in cm^{-1}). Because the Raman signal is dependent on the excitation wavelength, it can be convenient to use wavenumber to indicate the change of wavelength compared to excitation wavelength. Wavelength change is also photo energy change that is often described by wavenumber change in the frequency domain, because wavenumber is used to describe wavelength in the frequency domain. Wavelength can convert to wavenumbers by dividing one centimeter by wavelength.

[0099] As described herein, the light intensity signal acquired from a Raman spectrometer is influenced by the emission of fluorescence. For example, fluorescence is often much more intense than Raman scattering, and fluorescence can overwhelm or mask a Raman measurement in the light intensity signal. This can be seen in each of the signals of the graph 600. For example, the overall shape of each signal of the graph 600 is attributable to the fluorescence, while the subtle oscillations of each signal are attributable to Raman. Because the fluorescence tends to mask the Raman spectrum, it can be desirable to remove or reduce an effect of the fluorescence on the light intensity signal.

[0100] Various techniques for removing or reducing an effect of the fluorescence on the light intensity signal are known, including, but not limited to, confocal configuration, photobleaching, chemical bleaching, deployment of laser excitation at longer wavelengths, filtering with respect to pixel frequency (or wavenumber frequency), signal decomposition by various forms of component subtraction from a priori information, photobleaching curve fitting to subtract away an approximated fluorescence signal, frequency offset Raman methods, spatial offset Raman methods, or the like.

[0101] For example, irradiating tissue with intense laser light for a long period of time (sometimes referred to as photobleaching) can reduce a level of fluorescence emission in the light intensity signal, thus increasing the signal to noise (S/N) ratio of a Raman measurement. That is because the fluorescence signal of skin will decrease over time (experiencing an exponential decay) as a source is continually shining, while a Raman signal will not change. By looking at the exponential decay (in time) of photobleaching, the system can obtain a fluorescence approximation by curve fitting.

[0102] As another example, a system can use a first excitation wavelength to characterize the fluorescence, and then can subtract the fluorescence from a signal of a second excitation wavelength to isolate the Raman. For example, a location of peaks of the fluorescence emission are indepen-

dent of excitation wavelength, whereas a location of peaks and compactness of emission of Raman spectra are dependent on excitation wavelength. Using this information, the system can remove or reduce an effect of fluorescence emission in the light intensity signal. Fluorescence can also be removed by taking sequential measurements of the tissue over time. For example, the fluorescence signal can be isolated by the change of the measured spectrum overtime.

[0103] FIG. 7 illustrates a scaled view of the various example light intensity signals of FIG. 6. As described herein with respect to FIG. 6, the light intensity signals are influenced by, among other things, fluorescence, Raman scattering, and tissue absorption. For example, the light intensity signals can include a significant fluorescence baseline.

[0104] FIG. 8 illustrates an approximation of an intensity of the fluorescence portion 800 of the light intensity signals 700 of FIG. 7. This approximation of fluorescence can be determined using various techniques, such as those described herein. The system can utilize photobleaching curve fitting to subtract away an approximated fluorescence signal. For example, over time, the Raman signal (R_0) will remain constant while the fluorescence F_0 will experience an exponential decay. By looking at the exponential decay (in time) of photobleaching, the system can obtain a fluorescence approximation by curve fitting.

[0105] FIG. 9 illustrates an approximation of an intensity of the isolated Raman with tissue absorption signals of FIG. 7. In this example, at least some of the effect of fluorescence (for example, illustrated in FIG. 8) has been removed or reduced. Accordingly, the graph 700 of FIG. 7 can be approximately equal to the Raman and tissue absorption portion (for example, the $\Sigma(R_0 e^{-A_2})$ portion of Equation 6) of the light intensity signals of FIG. 6. As can be seen from a comparison of FIGS. 7 and 9, the presence of fluorescence in the light intensity signals 700 can mask many of the Raman features, such as the peaks, valleys, amplitude, compaction, and the like. By removing or reducing the presence of fluorescence in the light intensity signals 700, the system can isolate the Raman signal.

[0106] FIG. 10 illustrates an approximation of an intensity of the isolated Raman with tissue absorption signals of FIG. 7. In this example, the signal of graph 900 of FIG. 9 has been filtered to reduce or remove at least some of a remaining effect of fluorescence. For example, the system can filter the signal using a band pass or high pass filter.

Absorption

[0107] Another challenge in the implementation of Raman spectroscopy to obtain physiological data is the attenuation of the signal due to absorption. In some cases, the Raman signal can be isolated or improved by reducing or removing an effect of absorption on the measured signal. For example, sensor data from one or more sensors, such as a near infrared (NIR), reflectance, transmittance, or pulse oximetry sensor, can be utilized to determine absorption, which can be removed from one or more other measurements, such as a Raman measurement.

[0108] An effect of the tissue absorption (for example, the e^{-A} portion of Equation 6) may be removed or reduced in various ways. For example, the absorption data, transmission data, reflectance data, or the like may be determined using data from one or more sensors, such as, but not limited to, a near infrared (NIR), reflectance, transmittance, or pulse

oximetry sensor. Based on the sensor data, a processor can further process the signal (for example, signal **900** or **1000**) to reduce or subtract an effect of the attenuation of the signal due to absorption.

Tissue Geometry

[0109] Tissue geometry can vary greatly between individuals. For example, skin structure or skin thickness can vary across races, ages, or the like. Even individuals having similar demographics can have different skin geometries. FIGS. **11A-11C** illustrate optical scattering differences in skin geometries among various age groups. FIG. **11A** corresponds to 20-39 year olds, FIG. **11B** corresponds to 40-59 year-olds, and FIG. **11C** corresponds to 60-79 year-olds. In these examples, the x-axis corresponds to a compaction of the skin and is measured from 0 to 200 units, where one unit is 3 μm , and the y-axis corresponds to brightness (for example, backscattered intensity) of the skin and is measured from 0 to 800 AU (absorbance units). As evidenced by these graphs **1100A**, **1100B**, **1100C**, the general skin structure or thickness is not constant throughout the population.

[0110] Tissue geometry can be can also vary greatly between tissue sites of a particular individual. For example, each of a finger, a thumb, a thenar space of a hand, a wrist, a forearm, a nose, an ear, a neck, or other tissue site can have a different skin geometry. Even tissue sites that are in close proximity, such an upper part of a finger and a lower part of a finger, can have a different skin geometry.

Example Sensor Fusion Apparatus

[0111] A patient monitoring system such as systems **100** or **200** can include multiple noninvasive sensors. At least one sensor can be configured to provide tissue geometry information, and the system can utilize tissue geometry data to calibrate one or more other sensors or otherwise improve data obtained by the one or more other sensors. Techniques for utilizing sensor data to improve or calibrate another sensor can be referred to as data harmonization or sensor fusion.

[0112] As described herein, data acquired by a sensor can be a function of, or at least affected by, the tissue geometry of the particular tissue site that the sensor is interrogating. For example, tissues having a different geometry can result in a different optical profile. Consequently, data obtained from a first sensor at a first tissue site might not be useful for calibrating or improving a sensor that is interrogating a second, different tissue site. Accordingly, to accurately or reliably harmonize data between sensors, it can be helpful for each of the multiple sensors to acquire data associated with the same or a similar tissue site. In other words, it can be advantageous for each of the multiple sensors to interrogate the same or a sufficiently proximate tissue site so that a variable or other information determined using data from one sensor can be used to improve one or more others sensors. The present disclosure can provide for an apparatus configured allow multiple sensors to interrogate the same or a sufficiently proximate tissue site.

[0113] FIGS. **12A-12B** illustrate an example sensor fusion apparatus **1200** configured with multiple sensing capabilities for interrogation of the same or a sufficiently proximate tissue site. As shown, the apparatus **1200** can include an

OCT sensor or lens **1202**, a Raman spectrometer **1204**, a pulse oximetry sensor **1206**, and a bioimpedance sensor **1208**.

[0114] As illustrated in FIG. **12B**, the apparatus **1200** can include a cylindrical housing **1210**. In the illustrated example, the sensor side of the apparatus **1200** can be positioned on or proximate to a tissue site of a patient, and one or more of the an OCT sensor **1202**, a Raman spectrometer **1204**, a pulse oximetry sensor **1206**, and a bioimpedance sensor **1208** can be configured to interrogate the same or a sufficiently proximate tissue site. Although at least some of the sensors are illustrated as being configured to obtain data via reflectance technologies, in some cases one or more sensors are configured to obtain data via transmittance or other technologies.

Example Reflectance Sensor

[0115] FIG. **13** illustrates an example reflectance plethysmography sensor or probe **1300**. The reflectance sensor or probe **1300** includes a light source **1302** at its center and seven detector channels **1304** surrounding the light source **1302**. The light source **1302** and emit light to illuminate a tissue site, and one or more of the channels **1304** can detect the light after it interacts with the tissue site. In some cases, the one or more of the channels **1304** can generate a composite analog light intensity signal responsive to the detected light. In some cases, light source **1302** or the channels **1304** can include a fiber-optic component for illumination or collection. For example, the light source **1302** can include a fiber bundle.

[0116] FIG. **14** illustrates an environment **1400** that shows a hand of a user interacting with the example reflectance sensor **1300** of FIG. **13**. The reflectance sensor **1300** can be configured to interact with one or more of the various tissue sites described herein. For example, as illustrated, the reflectance sensor **1300** can be positioned to interrogate at a metacarpal bone **1306**. The metacarpal bone **1306** forms the intermediate part of the skeletal hand located between the phalanges of the fingers and the carpal bones of the wrist which forms the connection to the forearm.

Example Patient Monitoring

[0117] FIG. **15** illustrates an example physiological monitoring system **1500**, which can be an embodiment of the patient monitoring system **100** or **200**. As illustrated in FIG. **15**, the system **1500** can include a first sensor **1504A** and a second sensor **1504B**. In some implementations, the first sensor **1504A**, the second sensor **1504B**, or another sensor can be integrated into an apparatus, such as a wearable apparatus like a glove, a sock, an armband, a headband, a chest strap, etc.

[0118] The first sensor **1504A** can be similar to sensor **204A**, as described herein with respect to FIG. **2**. For example, the sensor **1504A** can include an emitter and detector. The emitter can emit light (for example, of an infrared or near-infrared wavelength) to illuminate a tissue site of a patient. In this example, the tissue site corresponds to a thenar space of the patient's hand. However, other tissue sites are contemplated. As the light interacts with (for example, passes through) the thenar space of the hand, some light may be absorbed, reflected, refracted, or the like. The detector can receive or generate a signal responsive to the light detected by the detector after it interacts with the thenar

space of the hand. The signal generated by the detector can be received by a processor (not shown), which can determine one or more various physiological parameters, such as an absorbance of the tissue based at least in part on the received signal.

[0119] The second sensor 1504B can be similar to sensor 204C, as described herein with respect to FIG. 2. For example, the second sensor 1504B can include a light source and a detector. The emitter can emit light (for example, of an infrared or near-infrared wavelength) to illuminate a tissue site of a patient. As the light interacts with (for example, reflects off) the thenar space of the hand, some light may be absorbed, transmitted through, reflected, refracted, or the like. The detector can receive or generate a signal responsive to the light detected by the detector after it interacts with the hand. The signal generated by the detector can be received by a processor (not shown), which can determine one or more various physiological parameters, such as a transmittance of the tissue based at least in part on the received signal.

[0120] FIGS. 16A-16C illustrate an example physiological monitoring apparatus 1600. As illustrated, a user can place his or her arm in the apparatus 1600, such that two or more sensors of the apparatus 1600 can interrogate tissue of the arm. The two or more sensors can correspond to any of the sensors described herein. For example, the two or more sensors can interrogate the same or a different tissue site of the arm. In some cases, the apparatus 1600 can be miniaturized and integrated into a wearable apparatus, such as a glove, a sock, an armband, a headband, a chest strap, etc.

Example Data Harmonization

[0121] FIG. 17 illustrates a flow diagram illustrative of an example routine for harmonizing data from a plurality of non-invasive sensors. One skilled in the relevant art will appreciate that the elements outlined for routine 1700 may be implemented by one or many computing devices/components, such as in hardware, with a front end component, with a sensor interface, or with a processor, such as one or more processors housed in a patient monitor, one or more remote processors, one or more processors housed in the sensors, etc. Accordingly, although routine 1700 has been logically associated as being generally performed by a processor, the following illustrative embodiments should not be construed as limiting.

[0122] At block 1702, a processor can receive data from one or more first noninvasive sensors. The one or more first noninvasive sensors can include an optical coherence tomography (OCT) sensor. As described herein, the OCT sensor can provide a non-invasive method for identifying one or more characteristics of a tissue's structure. The data received by the processor from the OCT sensor can include OCT data, which can be referred to as tissue geometry data.

[0123] In addition or alternatively, the one or more first noninvasive sensors can include a bioimpedance sensor or a tissue dielectric constant sensor. As described herein, the bioimpedance sensor or tissue dielectric constant sensor can provide a non-invasive method for identifying one or more characteristics of a tissue's structure. The data received by the processor from the bioimpedance sensor or tissue dielectric constant sensor can include bioimpedance data, which can include tissue geometry data, hydration data, or the like.

[0124] At block 1704, a processor can receive data from one or more second noninvasive sensors. The one or more

second noninvasive sensors can include a pulse oximetry sensor, such as a reflectance or transmission sensor. As described herein, the pulse oximetry sensor can provide a non-invasive method for identifying or more of various physiological parameters.

[0125] At block 1706, a processor can receive data from one or more third noninvasive sensors. The one or more second noninvasive sensors can include a Raman spectrometer. As described herein, the Raman spectrometer can provide a non-invasive method for identifying or more of various physiological parameters.

[0126] At block 1708, the processor can harmonize the data received from two or more of the non-invasive sensors. By harmonizing the data from two or more non-invasive sensors, the system may be able to compensate for circumstances that might otherwise result in inaccurate or unreliable data. For example, using skin geometry information (for example, skin thickness), the processor can weight or prioritize longer or shorter path length detectors. In addition or alternatively, the various sensor data, such as skin geometry information, can allow the processor compensate for sensor or probe placement. For example, a location, coupling, or pressure can be compensated by the processor by adjusting path length, which can be determined from the various sensor data, such as skin geometry information. Similarly, the processor can utilize the various sensor data, such as skin geometry information, to detect drift or motion at the tissue site.

[0127] As a non-limiting example, the data received at block 1702 from the OCT sensor, the bioelectrical impedance sensor, or the tissue dielectric constant sensor can include tissue geometry information. Based at least in part on the tissue geometry data, the processor can determine a path length corresponding to a tissue site interrogated by the one or more first noninvasive sensors. In some cases, the determined path length can be utilized with the pulse oximetry sensor to determine a concentration of an analyte, such as blood glucose. For example, based on the data received at block 1704 from the one or more second noninvasive sensors, the processor can determine an absorbance corresponding to a tissue site interrogated by the one or more second noninvasive sensors. Using one or more relationships derived from Beer's law (Equation 1), the concentration, c , of one or more analytes can be determined using the absorbance, A , determined from the pulse oximetry sensor data, and the path length, b , determined from the tissue geometry data.

[0128] As another non-limiting example, the processor can utilize the tissue geometry data to select a focal depth or focal length, wavelength, refractive index, or other parameter associated with the Raman spectrometer. For example, the tissue geometry data can provide an indication of a particular location of tissue, such as the capillary beds. The processor can select a focal depth or focal length of the Raman spectrometer such that the Raman spectrometer can focus on this particular location. As a result, the processor can determine a more accurate indication of glucose concentration from the Raman signal.

[0129] As another non-limiting example, the processor can utilize the pulse oximetry data to filter data received from a Raman Spectrometer to isolate a Raman Spectra. For example, as described herein, a direct measurement of glucose can be determined based on features of the isolated

Raman signal. Using the pulse oximetry data, the processor can filter out an effect of absorbance on the Raman Spectra.

[0130] In addition or alternatively, using the various sensor data, the processor can create calibrations for one or more individuals. For example, although skin geometry may vary between individuals, one or more groups of individuals may have similar skin geometries, which can allow for more accurate physiological parameter estimations of for individuals in those groups. For example, using the various sensor data, such as the skin geometry, Raman, or NIR data, the processor can determine calibrations for different groups, such as different skin populations, different ages, or the like.

[0131] The various blocks of process 1700 described herein can be implemented in a variety of orders, and that the system can implement one or more of the blocks concurrently or change the order, as desired. For example, the system 100 can concurrently receive any of the sensor data, or receive the sensor data in any order. Similarly, the system can make one or more calculations or determinations in any order, such as before or after receiving data from one or more sensors.

[0132] It will be understood that any of the first, second, or third sensors can interrogate the same or a different tissue site. Furthermore, it will be understood that fewer, more, or different blocks can be used as part of the routine 1700. Likewise, fewer, more, or different sensors can be used by the system. For example, the routine 1700 can include blocks for receiving data associated with additional non-invasive sensors or determining various other physiological parameters. Furthermore, the routine 1700 can include causing a display to display one or more of various indications of the any other the sensor data, calculations, or determinations.

[0133] FIG. 18 illustrates a flow diagram illustrative of an example routine for harmonizing data from a plurality of non-invasive sensors. One skilled in the relevant art will appreciate that the elements outlined for routine 1800 may be implemented by one or many computing devices/components, such as in hardware, with a front end component, with a sensor interface, or with a processor, such as one or more processors housed in a patient monitor, one or more remote processors, one or more processors housed in the sensors, etc. Accordingly, although routine 1800 has been logically associated as being generally performed by a processor, the following illustrative embodiments should not be construed as limiting.

[0134] At block 1802, the process 1800 can receive tissue geometry data from a first noninvasive sensor. As described herein, the first non-invasive sensor can include a combination of one or more of an OCT sensor, a bioimpedance sensor, a tissue dielectric constant sensor, or any other sensor configured to measure or determine tissue geometry data. The tissue geometry data can include various information corresponding to the skin, fluids, bones, or the like. For example, tissue geometry data can include, but is not limited to, a thickness of one or more skin layers (for example, the epidermis, the dermoepidermal junction, the papillary dermis, the reticular dermis, etc.), cellular structure information, a water content of a portion of the tissue, etc.

[0135] At block 1804, the process 1800 can calibrate a Raman Spectrometer based at least in part on the tissue geometry data received at block 1802. For example, the tissue geometry data can provide insight about the tissue

site, which can allow the process 1800 to optimize one or more settings of the Raman spectrometer. For example, based at least in part on the tissue geometry data, the process 1800 can select a focal depth or focal length, wavelength, refractive index, or other parameter associated with the Raman spectrometer. By adjusting one or more settings or positioning of the Raman spectrometer based on the tissue geometry data, the process can enhance a signal received by the Raman spectrometer. For example, the new settings can increase the collection efficiency, the resolution, the signal-to-noise ratio, or the like of the Raman signal.

[0136] At block 1806, the process 1800 can receive absorption, transmission, reflectance, or other data from a second noninvasive sensor. As described herein, the second non-invasive sensor can include one or more of a pulse oximetry sensor, a reflectance sensor, a transmittance sensor, or another sensor from which absorption, transmission, reflectance, or other tissue related data can be determined. In some cases, the second noninvasive sensor can include a light source configured to emit light and a detector and configured to detect light. Depending on the type of sensors, the detected can be configured to detect light after having it has passed through, reflected, refracted, or scattered at a tissue site of a patient. In some cases, the tissue site corresponding to the second sensor (for example, the tissue site at which the second sensor takes a measurement) is the same tissue site (or within a close proximity) as the tissue site of the second sensor. For example, the first and second sensors can be configured to interrogate the tissue site at different periods of time. However, in some cases, the first and second sensors can be configured to interrogate different tissue sites.

[0137] At 1808, the process 1800 can receive a Raman signal corresponding to the Raman spectrometer. As described herein, the light intensity signal acquired from a Raman spectrometer is influenced by the emission of fluorescence.

[0138] At block 1810, the process 1800 can determine an isolated Raman signal by reducing or removing an effect of fluorescence or an effect of absorption from the Raman signal received at block 1808. As described herein, fluorescence can overwhelm or mask a Raman measurement in the light intensity signal. As such, the process 1800 can use one or more techniques described herein to reduce or remove an effect of the fluorescence on the Raman signal. In addition or alternatively, the process 1800 can reduce or remove an effect of absorption on the Raman signal. For example, using the absorption data acquired at block 1806, the process 1800 can filter, subtract, reduce, or remove an effect of absorption on the Raman signal. By reducing or removing an effect of fluorescence or an effect of absorption from the Raman signal, the process 1800 can determine an isolated (or semi-isolated) Raman signal.

[0139] At block 1812, the process 1800 can determine data corresponding to one or more analytes based at least in part on the isolated Raman signal. For example, features of the Raman spectra (such as peaks, valleys, concentrations, etc.) can correspond to analytes such as glucose. Accordingly, using the isolated or semi-isolated Raman signal, the system can identify physiological data, such as information regarding a patient's blood glucose level. Thus, the process 1800 can harmonize data from various non-invasive sensors to non-invasively determine a patient's blood glucose level, or other analyte.

[0140] It will be understood that the various blocks of process **1800** described herein can be implemented in a variety of orders, and that the system can implement one or more of the blocks concurrently or change the order, as desired. Furthermore, it will be understood that fewer, more, or different blocks can be used as part of the routine **1800**. For example, fewer, more, or different sensors can be used by the system. Furthermore, the routine **1800** can include blocks for receiving data associated with additional non-invasive sensors or determining various other physiological parameters. Furthermore, the routine **1800** can include displaying one or more of various indications of the any other the sensor data, calculations, or determinations.

Further Examples

[0141] Various example features can be found in the following clauses, which can be implemented together with any combination of the features described above:

[0142] Clause 1: A physiological monitoring system configured to determine a physiological parameter by harmonizing data between two or more different types of non-invasive physiological sensors interrogating the same or proximate measurement sites, the physiological monitoring system comprising:

[0143] a first non-invasive sensing device of a first type configured to interrogate a tissue site of a patient and generate a first signal indicative of first physiological data associated with the tissue site;

[0144] a second non-invasive sensing device of a second type that is different from the first type configured to interrogate the tissue site of the patient and generate a second signal indicative of second physiological data associated with the tissue site; and

[0145] one or more processors in communication with the first and second non-invasive sensing devices, the one or more processors configured to:

[0146] receive the first signal indicative of the first physiological data;

[0147] receive the second signal indicative of the second physiological data; and

[0148] determine a physiological parameter based at least in part on the first and second signals.

[0149] Clause 2: The system of Clause 1, wherein the first non-invasive sensing device comprises one or more of an optical coherence tomography (OCT) sensor, a bioimpedance sensor, or a tissue dielectric constant sensor.

[0150] Clause 3: The system of any of the previous clauses, wherein the first physiological data comprises tissue geometry data corresponding to the tissue site.

[0151] Clause 4: The system of any of the previous clauses, wherein tissue geometry data comprises at least one of data corresponding to one or more of a thickness of one or more layers of skin of the tissue site, cellular structure information associated with the tissue site, or a water content associated with the tissue site.

[0152] Clause 5: The system of any of the previous clauses, wherein the first non-invasive sensing device comprises a plethysmography sensor.

[0153] Clause 6: The system of any of the previous clauses, wherein the plethysmography sensor comprises one or more of a pulse oximetry sensor, a transmission plethysmography sensor, or a reflectance plethysmography sensor.

[0154] Clause 7: The system of any of the previous clauses, wherein the plethysmography sensor comprises:

[0155] at least one emitter configured to emit light, and

[0156] at least one detector configured to:

[0157] detect the light after interaction with the tissue site, and

[0158] generate the second signal responsive to the detected light.

[0159] Clause 8: The system of any of the previous clauses, wherein the first non-invasive sensing device and the second non-invasive sensing device are configured to simultaneously interrogate the tissue site.

[0160] Clause 9: The system of any of the previous clauses, wherein the first non-invasive sensing device and the second non-invasive sensing device are configured to interrogate the tissue site at distinct and different time periods.

[0161] Clause 10: The system of any of the previous clauses, wherein the second non-invasive sensing device comprises a Raman spectrometer.

[0162] Clause 11: The system of any of the previous clauses, wherein the second physiological data corresponds to Raman spectra associated with the tissue site.

[0163] Clause 12: The system of any of the previous clauses, wherein the one or more processors are further configured to determine an isolated Raman signal by reducing or removing at least one of an effect of fluorescence or an effect of absorption from the second signal.

[0164] Clause 13: The system of any of the previous clauses, wherein the one or more processors are further configured to determine the isolated Raman signal based at least in part on the first signal.

[0165] Clause 14: The system of any of the previous clauses, wherein the one or more processors are further configured to determine a path length associated with the tissue site based at least in part on the first signal, wherein the determination of the physiological parameter is based at least in part on the determined path length.

[0166] Clause 15: The system of any of the previous clauses, wherein the one or more processors are further configured to determine an absorption of light of the tissue site based at least in part on the second signal, wherein the determination of the physiological parameter is based at least in part on the determined absorption of light.

[0167] Clause 16: The system of any of the previous clauses, wherein physiological parameter comprises a concentration of one or more analytes.

[0168] Clause 17: The system of any of the previous clauses, wherein physiological parameter comprises a blood glucose concentration associated with the tissue site.

[0169] Clause 18: The system of any of the previous clauses, wherein one or more processors are further configured to calibrate the second non-invasive sensing device based at least in part on the first signal.

[0170] Clause 19: The system of any of the previous clauses, wherein second non-invasive sensing device comprises a Raman spectrometer, wherein to calibrate the Raman spectrometer, the one or more processors are configured to select at least one of a focal depth, a focal length, a wavelength, or a refractive index, associated with the Raman spectrometer.

[0171] Clause 20: The system of any of the previous clauses, wherein the tissue site comprises a thenar space of a hand.

[0172] Clause 21: The system of any of the previous clauses, wherein the tissue site comprises an area associated with a metacarpal bone.

[0173] Clause 22: A method for determining a physiological parameter by harmonizing data between two or more different types of non-invasive physiological sensors interrogating the same or proximate measurement sites, the method comprising:

[0174] receiving a first signal from a first non-invasive sensing device of a first type, wherein the first non-invasive sensing device is configured to interrogate a tissue site of a patient and generate the first signal, wherein the first signal is indicative of first physiological data associated with the tissue site;

[0175] receiving a second signal from a second non-invasive sensing device of a second type that is different from the first type, wherein the second non-invasive sensing device is configured to interrogate the tissue site of the patient and generate the second signal, wherein the second signal is indicative of second physiological data associated with the tissue site; and/or determining a physiological parameter based at least in part on the first and second signals.

[0176] Clause 23: The method of Clause 22, wherein the first non-invasive sensing device comprises one or more of an optical coherence tomography (OCT) sensor, a bioimpedance sensor, or a tissue dielectric constant sensor.

[0177] Clause 24: The method of any of Clauses 22 or 23, wherein the first physiological data comprises tissue geometry data corresponding to the tissue site.

[0178] Clause 25: The method of any of Clauses 22-24, wherein tissue geometry data comprises at least one of data corresponding to one or more of a thickness of one or more layers of skin of the tissue site, cellular structure information associated with the tissue site, or a water content associated with the tissue site.

[0179] Clause 26: The method of Clauses 22-25, wherein the first non-invasive sensing device comprises a plethysmography sensor.

[0180] Clause 27: The method of Clauses 22-26, wherein the plethysmography sensor comprises one or more of a pulse oximetry sensor, a transmission plethysmography sensor, or a reflectance plethysmography sensor.

[0181] Clause 28: The method of Clauses 22-27, wherein the plethysmography sensor comprises:

[0182] at least one emitter configured to emit light, and

[0183] at least one detector configured to:

[0184] detect the light after interaction with the tissue site, and

[0185] generate the second signal responsive to the detected light.

[0186] Clause 29: The method of Clauses 22-28, wherein the first non-invasive sensing device and the second non-invasive sensing device are configured to simultaneously interrogate the tissue site.

[0187] Clause 30: The method of Clauses 22-29, wherein the first non-invasive sensing device and the second non-invasive sensing device are configured to interrogate the tissue site at distinct and different time periods.

[0188] Clause 31: The method of Clauses 22-30, wherein the second non-invasive sensing device comprises a Raman spectrometer.

[0189] Clause 32: The method of Clauses 22-31, wherein the second physiological data corresponds to Raman spectra associated with the tissue site.

[0190] Clause 33: The method of Clauses 22-32, further comprising determining an isolated Raman signal by reducing or removing at least one of an effect of fluorescence or an effect of absorption from the second signal.

[0191] Clause 34: The method of Clauses 22-33, wherein said determining the isolated Raman signal is based at least in part on the first signal.

[0192] Clause 35: The method of Clauses 22-34, further comprising determining a path length associated with the tissue site based at least in part on the first signal, wherein said determining the physiological parameter is based at least in part on the determined path length.

[0193] Clause 36: The method of Clauses 22-35, further comprising determining an absorption of light of the tissue site based at least in part on the second signal, wherein said determining the physiological parameter is based at least in part on the determined absorption of light.

[0194] Clause 37: The method of Clauses 22-36, wherein physiological parameter comprises a concentration of one or more analytes.

[0195] Clause 38: The method of Clauses 22-37, wherein physiological parameter comprises a blood glucose concentration associated with the tissue site.

[0196] Clause 39: The method of Clauses 22-38, further comprising calibrating the second non-invasive sensing device based at least in part on the first signal.

[0197] Clause 40: The method of Clauses 22-39, wherein second non-invasive sensing device comprises a Raman spectrometer, the method further comprising calibrating the Raman spectrometer by selecting at least one of a focal depth, a focal length, a wavelength, or a refractive index, associated with the Raman spectrometer.

[0198] Clause 41: The method of Clauses 22-40, wherein the tissue site comprises a thenar space of a hand.

[0199] Clause 42: The method of Clauses 22-41, wherein the tissue site comprises an area associated with a metacarpal bone.

[0200] Clause 43: A physiological monitoring device comprising any of the features of any of the previous clauses.

Terminology

[0201] The term “and/or” herein has its broadest least limiting meaning which is the disclosure includes A alone, B alone, both A and B together, or A or B alternatively, but does not require both A and B or require one of A or one of B. As used herein, the phrase “at least one of” A, B, “and” C should be construed to mean a logical A or B or C, using a non-exclusive logical or.

[0202] The following description is merely illustrative in nature and is in no way intended to limit the disclosure, its application, or uses. For purposes of clarity, the same reference numbers will be used in the drawings to identify similar elements. It should be understood that steps within a method may be executed in different order without altering the principles of the present disclosure.

[0203] Features, materials, characteristics, or groups described in conjunction with a particular aspect, embodiment, or example are to be understood to be applicable to any other aspect, embodiment or example described herein unless incompatible therewith. All of the features disclosed in this specification (including any accompanying claims,

abstract and drawings), or all of the steps of any method or process so disclosed, may be combined in any combination, except combinations where at least some of such features or steps are mutually exclusive. The protection is not restricted to the details of any foregoing embodiments. The protection extends to any novel one, or any novel combination, of the features disclosed in this specification (including any accompanying claims, abstract and drawings), or to any novel one, or any novel combination, of the steps of any method or process so disclosed.

[0204] While certain embodiments have been described, these embodiments have been presented by way of example only, and are not intended to limit the scope of protection. Indeed, the novel methods and systems described herein may be embodied in a variety of other forms. Furthermore, various omissions, substitutions and changes in the form of the methods and systems described herein may be made. Those skilled in the art will appreciate that in some embodiments, the actual steps taken in the processes illustrated or disclosed may differ from those shown in the figures. Depending on the embodiment, certain of the steps described above may be removed, others may be added. For example, the actual steps or order of steps taken in the disclosed processes may differ from those shown in the figures. Depending on the embodiment, certain of the steps described above may be removed, others may be added. For instance, the various components illustrated in the figures may be implemented as software or firmware on a processor, controller, ASIC, FPGA, or dedicated hardware. Hardware components, such as processors, ASICs, FPGAs, and the like, can include logic circuitry. Furthermore, the features and attributes of the specific embodiments disclosed above may be combined in different ways to form additional embodiments, all of which fall within the scope of the present disclosure.

[0205] User interface screens illustrated and described herein can include additional or alternative components. These components can include menus, lists, buttons, text boxes, labels, radio buttons, scroll bars, sliders, checkboxes, combo boxes, status bars, dialog boxes, windows, and the like. User interface screens can include additional or alternative information. Components can be arranged, grouped, displayed in any suitable order.

[0206] Although the present disclosure includes certain embodiments, examples and applications, it will be understood by those skilled in the art that the present disclosure extends beyond the specifically disclosed embodiments to other alternative embodiments or uses and obvious modifications and equivalents thereof, including embodiments which do not provide all of the features and advantages set forth herein. Accordingly, the scope of the present disclosure is not intended to be limited by the specific disclosures of preferred embodiments herein, and may be defined by claims as presented herein or as presented in the future.

[0207] Conditional language, such as “can,” “could,” “might,” or “may,” unless specifically stated otherwise, or otherwise understood within the context as used, is generally intended to convey that certain embodiments include, while other embodiments do not include, certain features, elements, or steps. Thus, such conditional language is not generally intended to imply that features, elements, or steps are in any way required for one or more embodiments or that one or more embodiments necessarily include logic for deciding, with or without user input or prompting, whether

these features, elements, or steps are included or are to be performed in any particular embodiment. The terms “comprising,” “including,” “having,” and the like are synonymous and are used inclusively, in an open-ended fashion, and do not exclude additional elements, features, acts, operations, and so forth. Also, the term “or” is used in its inclusive sense (and not in its exclusive sense) so that when used, for example, to connect a list of elements, the term “or” means one, some, or all of the elements in the list. Further, the term “each,” as used herein, in addition to having its ordinary meaning, can mean any subset of a set of elements to which the term “each” is applied.

[0208] Conjunctive language such as the phrase “at least one of X, Y, and Z,” unless specifically stated otherwise, is otherwise understood with the context as used in general to convey that an item, term, etc. may be either X, Y, or Z. Thus, such conjunctive language is not generally intended to imply that certain embodiments require the presence of at least one of X, at least one of Y, and at least one of Z.

[0209] Language of degree used herein, such as the terms “approximately,” “about,” “generally,” and “substantially” as used herein represent a value, amount, or characteristic close to the stated value, amount, or characteristic that still performs a desired function or achieves a desired result. For example, the terms “approximately,” “about,” “generally,” and “substantially” may refer to an amount that is within less than 10% of, within less than 5% of, within less than 1% of, within less than 0.1% of, and within less than 0.01% of the stated amount. As another example, in certain embodiments, the terms “generally parallel” and “substantially parallel” refer to a value, amount, or characteristic that departs from exactly parallel by less than or equal to 15 degrees, 10 degrees, 5 degrees, 3 degrees, 1 degree, or 0.1 degree.

[0210] The scope of the present disclosure is not intended to be limited by the specific disclosures of preferred embodiments in this section or elsewhere in this specification, and may be defined by claims as presented in this section or elsewhere in this specification or as presented in the future. The language of the claims is to be interpreted broadly based on the language employed in the claims and not limited to the examples described in the present specification or during the prosecution of the application, which examples are to be construed as non-exclusive.

What is claimed is:

1. A physiological monitoring system configured to determine a physiological parameter by harmonizing data between two or more different types of non-invasive physiological sensors interrogating the same or proximate measurement sites, the physiological monitoring system comprising:

a first non-invasive sensing device of a first type configured to interrogate a tissue site of a patient and generate a first signal indicative of first physiological data associated with the tissue site;

a second non-invasive sensing device of a second type that is different from the first type configured to interrogate the tissue site of the patient and generate a second signal indicative of second physiological data associated with the tissue site; and

one or more processors in communication with the first and second non-invasive sensing devices, the one or more processors configured to:

receive the first signal indicative of the first physiological data;

- receive the second signal indicative of the second physiological data; and
determine a physiological parameter based at least in part on the first and second signals.
2. The system of claim 1, wherein the first non-invasive sensing device comprises one or more of an optical coherence tomography (OCT) sensor, a bioimpedance sensor, or a tissue dielectric constant sensor, wherein the first physiological data comprises tissue geometry data corresponding to the tissue site.
3. The system of claim 2, wherein tissue geometry data comprises at least one of data corresponding to one or more of a thickness of one or more layers of skin of the tissue site, cellular structure information associated with the tissue site, or a water content associated with the tissue site.
4. The system of claim 1, wherein the first non-invasive sensing device comprises a plethysmography sensor, wherein the plethysmography sensor comprises one or more of a pulse oximetry sensor, a transmission plethysmography sensor, or a reflectance plethysmography sensor.
5. The system of claim 1, wherein the first non-invasive sensing device and the second non-invasive sensing device are configured to simultaneously interrogate the tissue site.
6. The system of claim 1, wherein the first non-invasive sensing device and the second non-invasive sensing device are configured to interrogate the tissue site at distinct and different time periods.
7. The system of claim 1, wherein the second non-invasive sensing device comprises a Raman spectrometer, wherein the second physiological data corresponds to Raman spectra associated with the tissue site.
8. The system of claim 7, wherein the one or more processors are further configured to determine an isolated Raman signal by reducing or removing at least one of an effect of fluorescence or an effect of absorption from the second signal.
9. The system of claim 1, wherein the one or more processors are further configured to determine a path length associated with the tissue site based at least in part on the first signal, wherein the determination of the physiological parameter is based at least in part on the determined path length.
10. The system of claim 1, wherein the one or more processors are further configured to determine an absorption of light of the tissue site based at least in part on the second signal, wherein the determination of the physiological parameter is based at least in part on the determined absorption of light.
11. The system of claim 1, wherein physiological parameter comprises a blood glucose concentration associated with the tissue site.
12. The system of claim 16, wherein second non-invasive sensing device comprises a Raman spectrometer, wherein one or more processors are further configured to calibrate the second non-invasive sensing device based at least in part

on the first signal, wherein to calibrate the Raman spectrometer, the one or more processors are configured to select at least one of a focal depth, a focal length, a wavelength, or a refractive index, associated with the Raman spectrometer.

13. A method for determining a physiological parameter by harmonizing data between two or more different types of non-invasive physiological sensors interrogating the same or proximate measurement sites, the method comprising:

receiving a first signal from a first non-invasive sensing device of a first type, wherein the first non-invasive sensing device is configured to interrogate a tissue site of a patient and generate the first signal, wherein the first signal is indicative of first physiological data associated with the tissue site;

receiving a second signal from a second non-invasive sensing device of a second type that is different from the first type, wherein the second non-invasive sensing device is configured to interrogate the tissue site of the patient and generate the second signal, wherein the second signal is indicative of second physiological data associated with the tissue site;

determining a physiological parameter based at least in part on the first and second signals.

14. The method of claim 13, wherein the first non-invasive sensing device comprises one or more of an optical coherence tomography (OCT) sensor, a bioimpedance sensor, or a tissue dielectric constant sensor, wherein the first physiological data comprises tissue geometry data corresponding to the tissue site.

15. The method of claim 13, wherein the first non-invasive sensing device comprises a plethysmography sensor, wherein the plethysmography sensor comprises one or more of a pulse oximetry sensor, a transmission plethysmography sensor, or a reflectance plethysmography sensor.

16. The method of claim 13, wherein the first non-invasive sensing device and the second non-invasive sensing device are configured to simultaneously interrogate the tissue site.

17. The method of claim 13, wherein the second non-invasive sensing device comprises a Raman spectrometer.

18. The method of claim 13, further comprising determining an isolated Raman signal by reducing or removing at least one of an effect of fluorescence or an effect of absorption from the second signal.

19. The method of claim 13, further comprising determining a path length associated with the tissue site based at least in part on the first signal, wherein said determining the physiological parameter is based at least in part on the determined path length.

20. The method of claim 13, further comprising determining an absorption of light of the tissue site based at least in part on the second signal, wherein said determining the physiological parameter is based at least in part on the determined absorption of light.

* * * * *

专利名称(译)	用于协调生理测量的医疗监控设备		
公开(公告)号	US20190015023A1	公开(公告)日	2019-01-17
申请号	US16/034743	申请日	2018-07-13
[标]申请(专利权)人(译)	CERCACOR LAB		
申请(专利权)人(译)	CERCACOR LABORATORIES, INC.		
当前申请(专利权)人(译)	CERCACOR LABORATORIES, INC.		
[标]发明人	MONFRE STEPHEN LEONARD		
发明人	MONFRE, STEPHEN LEONARD		
IPC分类号	A61B5/145 A61B5/00 A61B5/0205		
CPC分类号	A61B5/14532 A61B2576/02 A61B5/7203 A61B5/0205 A61B5/7278 A61B2560/0223 A61B5/0295 A61B5/0261 A61B5/14551 A61B5/0066 A61B5/0531 A61B5/1075 A61B5/1079 A61B5/443 A61B5/0075 A61B5/442		
优先权	62/532273 2017-07-13 US 62/667983 2018-05-07 US		
外部链接	Espacenet USPTO		

摘要(译)

描述了用于协调来自多个非侵入式传感器的数据的系统，方法，装置和医疗设备。可以通过在询问相同或接近的测量位置的两种或更多种不同类型的非侵入性生理传感器之间协调数据来确定生理参数。来自一个或多个第一非侵入式传感器的数据可用于识别在与来自一个或多个第二非侵入式传感器的数据相关联的一个或多个计算中有用的一个或多个变量。来自一个或多个第一非侵入式传感器的数据可用于校准一个或多个第二非侵入式传感器。非侵入式传感器可包括但不限于光学相干断层扫描(OCT)传感器，生物阻抗传感器，组织介电常数传感器，体积描记器传感器或拉曼光谱仪。

