



US009750442B2

(12) **United States Patent**  
**Olsen**

(10) **Patent No.:** **US 9,750,442 B2**  
(45) **Date of Patent:** **Sep. 5, 2017**

- (54) **PHYSIOLOGICAL STATUS MONITOR**
- (71) Applicant: **Masimo Corporation**, Irvine, CA (US)
- (72) Inventor: **Gregory A. Olsen**, Trabuco Canyon, CA (US)
- (73) Assignee: **Masimo Corporation**, Irvine, CA (US)
- (\* ) Notice: Subject to any disclaimer, the term of this patent is extended or adjusted under 35 U.S.C. 154(b) by 50 days.
- (21) Appl. No.: **14/203,524**
- (22) Filed: **Mar. 10, 2014**

5,041,187 A	8/1991	Hink et al.
5,069,213 A	12/1991	Polczynski
5,163,438 A	11/1992	Gordon et al.
5,319,355 A	6/1994	Russek
5,337,744 A	8/1994	Branigan
5,341,805 A	8/1994	Stavridi et al.
D353,195 S	12/1994	Savage et al.
D353,196 S	12/1994	Savage et al.
5,377,676 A	1/1995	Vari et al.
D359,546 S	6/1995	Savage et al.
5,431,170 A	7/1995	Mathews
D361,840 S	8/1995	Savage et al.
D362,063 S	9/1995	Savage et al.
5,452,717 A	9/1995	Branigan et al.
D363,120 S	10/1995	Savage et al.
5,456,252 A	10/1995	Vari et al.
5,479,934 A	1/1996	Imran

(Continued)

(65) **Prior Publication Data**  
US 2015/0051462 A1 Feb. 19, 2015

**OTHER PUBLICATIONS**

US 8,845,543, 09/2014, Diab et al. (withdrawn)  
(Continued)

**Related U.S. Application Data**

(60) Provisional application No. 61/775,568, filed on Mar. 9, 2013.

*Primary Examiner* — Kumar Patel  
*Assistant Examiner* — Richard M Russell  
(74) *Attorney, Agent, or Firm* — Knobbe Martens Olson & Bear, LLP

- (51) **Int. Cl.**  
*A61B 5/145* (2006.01)  
*A61B 5/00* (2006.01)
- (52) **U.S. Cl.**  
CPC ..... *A61B 5/14542* (2013.01); *A61B 5/743* (2013.01); *A61B 5/7275* (2013.01); *A61B 5/746* (2013.01)

(57) **ABSTRACT**

A physiological status monitor has a monitor and an inter-connected sensor that generates a sensor signal. The monitor computes physiological parameters responsive to the sensor signal and displays physiological parameters accordingly. In an embodiment, the monitor displays physiological parameter information across multiple patients in a cumulative pie chart format so that a caregiver can quickly discern and readily identify patients in need of immediate medical attention.

(58) **Field of Classification Search**  
None  
See application file for complete search history.

(56) **References Cited**  
U.S. PATENT DOCUMENTS

- 4,960,128 A 10/1990 Gordon et al.
- 4,964,408 A 10/1990 Hink et al.

**3 Claims, 8 Drawing Sheets**

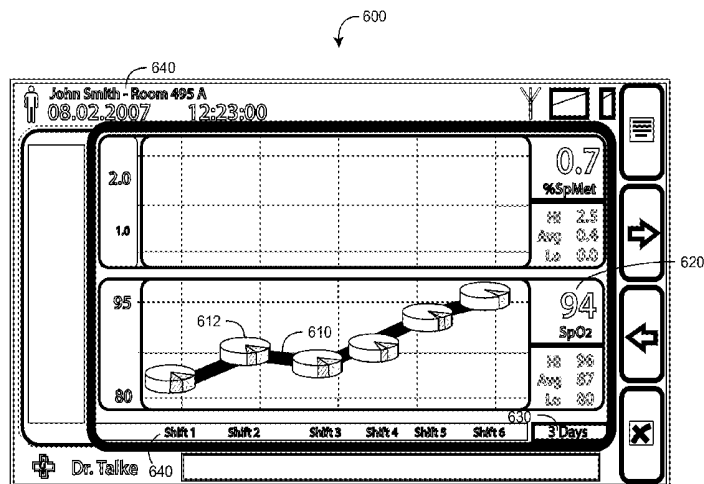

(56)

## References Cited

## U.S. PATENT DOCUMENTS

5,482,036	A	1/1996	Diab et al.	6,397,091	B2	5/2002	Diab et al.
5,490,505	A	2/1996	Diab et al.	6,430,437	B1	8/2002	Marro
5,494,043	A	2/1996	O'Sullivan et al.	6,430,525	B1	8/2002	Weber et al.
5,533,511	A	7/1996	Kaspari et al.	6,463,311	B1	10/2002	Diab
5,534,851	A	7/1996	Russek	6,470,199	B1	10/2002	Kopotic et al.
5,561,275	A	10/1996	Savage et al.	6,501,975	B2	12/2002	Diab et al.
5,562,002	A	10/1996	Lalin	6,505,059	B1	1/2003	Kollias et al.
5,590,649	A	1/1997	Caro et al.	6,515,273	B2	2/2003	Al-Ali
5,602,924	A	2/1997	Durand et al.	6,519,487	B1	2/2003	Parker
5,632,272	A	5/1997	Diab et al.	6,525,386	B1	2/2003	Mills et al.
5,638,816	A	6/1997	Kiani-Azarbayjany et al.	6,526,300	B1	2/2003	Kiani et al.
5,638,818	A	6/1997	Diab et al.	6,541,756	B2	4/2003	Schulz et al.
5,645,440	A	7/1997	Tobler et al.	6,542,764	B1	4/2003	Al-Ali et al.
5,685,299	A	11/1997	Diab et al.	6,580,086	B1	6/2003	Schulz et al.
D393,830	S	4/1998	Tobler et al.	6,584,336	B1	6/2003	Ali et al.
5,743,262	A	4/1998	Lepper, Jr. et al.	6,595,316	B2	7/2003	Cybulski et al.
5,758,644	A	6/1998	Diab et al.	6,597,932	B2	7/2003	Tian et al.
5,760,910	A	6/1998	Lepper, Jr. et al.	6,597,933	B2	7/2003	Kiani et al.
5,769,785	A	6/1998	Diab et al.	6,606,511	B1	8/2003	Ali et al.
5,782,757	A	7/1998	Diab et al.	6,632,181	B2	10/2003	Flaherty et al.
5,785,659	A	7/1998	Caro et al.	6,639,668	B1	10/2003	Trepagnier
5,791,347	A	8/1998	Flaherty et al.	6,640,116	B2	10/2003	Diab
5,810,734	A	9/1998	Caro et al.	6,643,530	B2	11/2003	Diab et al.
5,823,950	A	10/1998	Diab et al.	6,650,917	B2	11/2003	Diab et al.
5,830,131	A	11/1998	Caro et al.	6,654,624	B2	11/2003	Diab et al.
5,833,618	A	11/1998	Caro et al.	6,658,276	B2	12/2003	Kiani et al.
5,860,919	A	1/1999	Kiani-Azarbayjany et al.	6,661,161	B1	12/2003	Lanzo et al.
5,890,929	A	4/1999	Mills et al.	6,671,531	B2	12/2003	Al-Ali et al.
5,904,654	A	5/1999	Wohlmann et al.	6,678,543	B2	1/2004	Diab et al.
5,919,134	A	7/1999	Diab	6,684,090	B2	1/2004	Ali et al.
5,934,925	A	8/1999	Tobler et al.	6,684,091	B2	1/2004	Parker
5,940,182	A	8/1999	Lepper, Jr. et al.	6,697,656	B1	2/2004	Al-Ali
5,995,855	A	11/1999	Kiani et al.	6,697,657	B1	2/2004	Shehada et al.
5,997,343	A	12/1999	Mills et al.	6,697,658	B2	2/2004	Al-Ali
6,002,952	A	12/1999	Diab et al.	RE38,476	E	3/2004	Diab et al.
6,011,986	A	1/2000	Diab et al.	6,699,194	B1	3/2004	Diab et al.
6,027,452	A	2/2000	Flaherty et al.	6,714,804	B2	3/2004	Al-Ali et al.
6,036,642	A	3/2000	Diab et al.	RE38,492	E	4/2004	Diab et al.
6,045,509	A	4/2000	Caro et al.	6,721,582	B2	4/2004	Trepagnier et al.
6,067,462	A	5/2000	Diab et al.	6,721,585	B1	4/2004	Parker
6,081,735	A	6/2000	Diab et al.	6,725,075	B2	4/2004	Al-Ali
6,088,607	A	7/2000	Diab et al.	6,728,560	B2	4/2004	Kollias et al.
6,110,522	A	8/2000	Lepper, Jr. et al.	6,735,459	B2	5/2004	Parker
6,124,597	A	9/2000	Shehada	6,745,060	B2	6/2004	Diab et al.
6,128,521	A	10/2000	Marro et al.	6,760,607	B2	7/2004	Al-Ali
6,129,675	A	10/2000	Jay	6,770,028	B1	8/2004	Ali et al.
6,144,868	A	11/2000	Parker	6,771,994	B2	8/2004	Kiani et al.
6,151,516	A	11/2000	Kiani-Azarbayjany et al.	6,792,300	B1	9/2004	Diab et al.
6,152,754	A	11/2000	Gerhardt et al.	6,813,511	B2	11/2004	Diab et al.
6,157,850	A	12/2000	Diab et al.	6,816,741	B2	11/2004	Diab
6,165,005	A	12/2000	Mills et al.	6,822,564	B2	11/2004	Al-Ali
6,184,521	B1	2/2001	Coffin, IV et al.	6,826,419	B2	11/2004	Diab et al.
6,206,830	B1	3/2001	Diab et al.	6,830,711	B2	12/2004	Mills et al.
6,229,856	B1	5/2001	Diab et al.	6,850,787	B2	2/2005	Weber et al.
6,232,609	B1	5/2001	Snyder et al.	6,850,788	B2	2/2005	Al-Ali
6,236,872	B1	5/2001	Diab et al.	6,852,083	B2	2/2005	Caro et al.
6,241,683	B1	6/2001	Macklem et al.	6,861,639	B2	3/2005	Al-Ali
6,253,097	B1	6/2001	Aronow et al.	6,898,452	B2	5/2005	Al-Ali et al.
6,256,523	B1	7/2001	Diab et al.	6,920,345	B2	7/2005	Al-Ali et al.
6,263,222	B1	7/2001	Diab et al.	6,931,268	B1	8/2005	Kiani-Azarbayjany et al.
6,278,522	B1	8/2001	Lepper, Jr. et al.	6,934,570	B2	8/2005	Kiani et al.
6,280,213	B1	8/2001	Tobler et al.	6,939,305	B2	9/2005	Flaherty et al.
6,285,896	B1	9/2001	Tobler et al.	6,943,348	B1	9/2005	Coffin, IV
6,301,493	B1	10/2001	Marro et al.	6,950,687	B2	9/2005	Al-Ali
6,317,627	B1	11/2001	Ennen et al.	6,961,598	B2	11/2005	Diab
6,321,100	B1	11/2001	Parker	6,970,792	B1	11/2005	Diab
6,325,761	B1	12/2001	Jay	6,979,812	B2	12/2005	Al-Ali
6,334,065	B1	12/2001	Al-Ali et al.	6,985,764	B2	1/2006	Mason et al.
6,343,224	B1	1/2002	Parker	6,993,371	B2	1/2006	Kiani et al.
6,349,228	B1	2/2002	Kiani et al.	6,996,427	B2	2/2006	Ali et al.
6,360,114	B1	3/2002	Diab et al.	6,999,904	B2	2/2006	Weber et al.
6,368,283	B1	4/2002	Xu et al.	7,003,338	B2	2/2006	Weber et al.
6,371,921	B1	4/2002	Caro et al.	7,003,339	B2	2/2006	Diab et al.
6,377,829	B1	4/2002	Al-Ali	7,015,451	B2	3/2006	Dalke et al.
6,388,240	B2	5/2002	Schulz et al.	7,024,233	B2	4/2006	Ali et al.
				7,027,849	B2	4/2006	Al-Ali
				7,030,749	B2	4/2006	Al-Ali
				7,039,449	B2	5/2006	Al-Ali
				7,041,060	B2	5/2006	Flaherty et al.

(56)

## References Cited

## U.S. PATENT DOCUMENTS

7,044,918 B2	5/2006	Diab	RE41,317 E	5/2010	Parker
7,067,893 B2	6/2006	Mills et al.	7,729,733 B2	6/2010	Al-Ali et al.
7,096,052 B2	8/2006	Mason et al.	7,734,320 B2	6/2010	Al-Ali
7,096,054 B2	8/2006	Abdul-Hafiz et al.	7,761,127 B2	7/2010	Al-Ali et al.
7,132,641 B2	11/2006	Schulz et al.	7,761,128 B2	7/2010	Al-Ali et al.
7,142,901 B2	11/2006	Kiani et al.	7,764,982 B2	7/2010	Dalke et al.
7,149,561 B2	12/2006	Diab	D621,516 S	8/2010	Kiani et al.
7,186,966 B2	3/2007	Al-Ali	7,791,155 B2	9/2010	Diab
7,190,261 B2	3/2007	Al-Ali	7,801,581 B2	9/2010	Diab
7,215,984 B2	5/2007	Diab	7,822,452 B2	10/2010	Schurman et al.
7,215,986 B2	5/2007	Diab	RE41,912 E	11/2010	Parker
7,221,971 B2	5/2007	Diab	7,844,313 B2	11/2010	Kiani et al.
7,225,006 B2	5/2007	Al-Ali et al.	7,844,314 B2	11/2010	Al-Ali
7,225,007 B2	5/2007	Al-Ali	7,844,315 B2	11/2010	Al-Ali
RE39,672 E	6/2007	Shehada et al.	7,865,222 B2	1/2011	Weber et al.
7,239,905 B2	7/2007	Kiani-Azarbayjany et al.	7,873,497 B2	1/2011	Weber et al.
7,245,953 B1	7/2007	Parker	7,880,606 B2	2/2011	Al-Ali
7,254,429 B2	8/2007	Schurman et al.	7,880,626 B2	2/2011	Al-Ali et al.
7,254,431 B2	8/2007	Al-Ali	7,891,355 B2	2/2011	Al-Ali et al.
7,254,433 B2	8/2007	Diab et al.	7,894,868 B2	2/2011	Al-Ali et al.
7,254,434 B2	8/2007	Schulz et al.	7,899,507 B2	3/2011	Al-Ali et al.
7,272,425 B2	9/2007	Al-Ali	7,899,518 B2	3/2011	Trepagnier et al.
7,274,955 B2	9/2007	Kiani et al.	7,904,132 B2	3/2011	Weber et al.
D554,263 S	10/2007	Al-Ali	7,909,772 B2	3/2011	Popov et al.
7,280,858 B2	10/2007	Al-Ali et al.	7,910,875 B2	3/2011	Al-Ali
7,289,835 B2	10/2007	Mansfield et al.	7,919,713 B2	4/2011	Al-Ali et al.
7,292,883 B2	11/2007	De Felice et al.	7,937,128 B2	5/2011	Al-Ali
7,295,866 B2	11/2007	Al-Ali	7,937,129 B2	5/2011	Mason et al.
7,328,053 B1	2/2008	Diab et al.	7,937,130 B2	5/2011	Diab et al.
7,332,784 B2	2/2008	Mills et al.	7,941,199 B2	5/2011	Kiani
7,340,287 B2	3/2008	Mason et al.	7,951,086 B2	5/2011	Flaherty et al.
7,341,559 B2	3/2008	Schulz et al.	7,957,780 B2	6/2011	Lamego et al.
7,343,186 B2	3/2008	Lamego et al.	7,962,188 B2	6/2011	Kiani et al.
D566,282 S	4/2008	Al-Ali et al.	7,962,190 B1	6/2011	Diab et al.
7,355,512 B1	4/2008	Al-Ali	7,976,472 B2	7/2011	Kiani
7,356,365 B2	4/2008	Schurman	7,988,637 B2	8/2011	Diab
7,371,981 B2	5/2008	Abdul-Hafiz	7,990,382 B2	8/2011	Kiani
7,373,193 B2	5/2008	Al-Ali et al.	7,991,446 B2	8/2011	Ali et al.
7,373,194 B2	5/2008	Weber et al.	8,000,761 B2	8/2011	Al-Ali
7,376,453 B1	5/2008	Diab et al.	8,008,088 B2	8/2011	Bellott et al.
7,377,794 B2	5/2008	Al-Ali et al.	RE42,753 E	9/2011	Kiani-Azarbayjany et al.
7,377,899 B2	5/2008	Weber et al.	8,019,400 B2	9/2011	Diab et al.
7,383,070 B2	6/2008	Diab et al.	8,028,701 B2	10/2011	Al-Ali et al.
7,415,297 B2	8/2008	Al-Ali et al.	8,029,765 B2	10/2011	Bellott et al.
7,428,432 B2	9/2008	Ali et al.	8,036,727 B2	10/2011	Schurman et al.
7,438,683 B2	10/2008	Al-Ali et al.	8,036,728 B2	10/2011	Diab et al.
7,440,787 B2	10/2008	Diab	8,046,040 B2	10/2011	Ali et al.
7,454,240 B2	11/2008	Diab et al.	8,046,041 B2	10/2011	Diab et al.
7,467,002 B2	12/2008	Weber et al.	8,046,042 B2	10/2011	Diab et al.
7,469,157 B2	12/2008	Diab et al.	8,048,040 B2	11/2011	Kiani
7,471,969 B2	12/2008	Diab et al.	8,050,728 B2	11/2011	Al-Ali et al.
7,471,971 B2	12/2008	Diab et al.	RE43,169 E	2/2012	Parker
7,483,729 B2	1/2009	Al-Ali et al.	8,118,620 B2	2/2012	Al-Ali et al.
7,483,730 B2	1/2009	Diab et al.	8,126,528 B2	2/2012	Diab et al.
7,489,958 B2	2/2009	Diab et al.	8,128,572 B2	3/2012	Diab et al.
7,496,391 B2	2/2009	Diab et al.	8,130,105 B2	3/2012	Al-Ali et al.
7,496,393 B2	2/2009	Diab et al.	8,145,287 B2	3/2012	Diab et al.
D587,657 S	3/2009	Al-Ali et al.	8,150,487 B2	4/2012	Diab et al.
7,499,741 B2	3/2009	Diab et al.	8,175,672 B2	5/2012	Parker
7,499,835 B2	3/2009	Weber et al.	8,180,420 B2	5/2012	Diab et al.
7,500,950 B2	3/2009	Al-Ali et al.	8,182,443 B1	5/2012	Kiani
7,509,154 B2	3/2009	Diab et al.	8,185,180 B2	5/2012	Diab et al.
7,509,494 B2	3/2009	Al-Ali	8,190,223 B2	5/2012	Al-Ali et al.
7,510,849 B2	3/2009	Schurman et al.	8,190,227 B2	5/2012	Diab et al.
7,526,328 B2	4/2009	Diab et al.	8,203,438 B2	6/2012	Kiani et al.
7,530,942 B1	5/2009	Diab	8,203,704 B2	6/2012	Merritt et al.
7,530,949 B2	5/2009	Al Ali et al.	8,204,566 B2	6/2012	Schurman et al.
7,530,955 B2	5/2009	Diab et al.	8,219,172 B2	7/2012	Schurman et al.
7,563,110 B2	7/2009	Al-Ali et al.	8,224,411 B2	7/2012	Al-Ali et al.
7,596,398 B2	9/2009	Al-Ali et al.	8,228,181 B2	7/2012	Al-Ali
7,618,375 B2	11/2009	Flaherty	8,229,533 B2	7/2012	Diab et al.
D606,659 S	12/2009	Kiani et al.	8,233,955 B2	7/2012	Al-Ali et al.
7,647,083 B2	1/2010	Al-Ali et al.	8,244,325 B2	8/2012	Al-Ali et al.
D609,193 S	2/2010	Al-Ali et al.	8,255,026 B1	8/2012	Al-Ali
D614,305 S	4/2010	Al-Ali et al.	8,255,027 B2	8/2012	Al-Ali et al.
			8,255,028 B2	8/2012	Al-Ali et al.
			8,260,577 B2	9/2012	Weber et al.
			8,265,723 B1	9/2012	McHale et al.
			8,274,360 B2	9/2012	Sampath et al.

(56)

## References Cited

## U.S. PATENT DOCUMENTS

8,301,217	B2	10/2012	Al-Ali et al.	8,700,112	B2	4/2014	Kiani
8,306,596	B2	11/2012	Schurman et al.	8,702,627	B2	4/2014	Telfort et al.
8,310,336	B2	11/2012	Muhsin et al.	8,706,179	B2	4/2014	Parker
8,315,683	B2	11/2012	Al-Ali et al.	8,712,494	B1	4/2014	MacNeish, III et al.
RE43,860	E	12/2012	Parker	8,715,206	B2	5/2014	Telfort et al.
8,337,403	B2	12/2012	Al-Ali et al.	8,718,735	B2	5/2014	Lamego et al.
8,346,330	B2	1/2013	Lamego	8,718,737	B2	5/2014	Diab et al.
8,353,842	B2	1/2013	Al-Ali et al.	8,718,738	B2	5/2014	Blank et al.
8,355,766	B2	1/2013	Macneish, III et al.	8,720,249	B2	5/2014	Al-Ali
8,359,080	B2	1/2013	Diab et al.	8,721,541	B2	5/2014	Al-Ali et al.
8,364,223	B2	1/2013	Al-Ali et al.	8,721,542	B2	5/2014	Al-Ali et al.
8,364,226	B2	1/2013	Diab et al.	8,723,677	B1	5/2014	Kiani
8,374,665	B2	2/2013	Lamego	8,740,792	B1	6/2014	Kiani et al.
8,385,995	B2	2/2013	Al-Ali et al.	8,754,776	B2	6/2014	Poeze et al.
8,385,996	B2	2/2013	Smith et al.	8,755,535	B2	6/2014	Telfort et al.
8,388,353	B2	3/2013	Kiani et al.	8,755,856	B2	6/2014	Diab et al.
8,399,822	B2	3/2013	Al-Ali	8,755,872	B1	6/2014	Marinow
8,401,602	B2	3/2013	Kiani	8,761,850	B2	6/2014	Lamego
8,405,608	B2	3/2013	Al-Ali et al.	8,764,671	B2	7/2014	Kiani
8,414,499	B2	4/2013	Al-Ali et al.	8,768,423	B2	7/2014	Shakespeare et al.
8,418,524	B2	4/2013	Al-Ali	8,771,204	B2	7/2014	Telfort et al.
8,423,106	B2	4/2013	Lamego et al.	8,777,634	B2	7/2014	Kiani et al.
8,428,967	B2	4/2013	Olsen et al.	8,781,543	B2	7/2014	Diab et al.
8,430,817	B1	4/2013	Al-Ali et al.	8,781,544	B2	7/2014	Al-Ali et al.
8,437,825	B2	5/2013	Dalvi et al.	8,781,549	B2	7/2014	Al-Ali et al.
8,455,290	B2	6/2013	Siskavich	8,788,003	B2	7/2014	Schurman et al.
8,457,703	B2	6/2013	Al-Ali	8,790,268	B2	7/2014	Al-Ali
8,457,707	B2	6/2013	Kiani	8,801,613	B2	8/2014	Al-Ali et al.
8,463,349	B2	6/2013	Diab et al.	8,821,397	B2	9/2014	Al-Ali et al.
8,466,286	B2	6/2013	Bellott et al.	8,821,415	B2	9/2014	Al-Ali et al.
8,471,713	B2	6/2013	Poeze et al.	8,830,449	B1	9/2014	Lamego et al.
8,473,020	B2	6/2013	Kiani et al.	8,831,700	B2	9/2014	Schurman et al.
8,483,787	B2	7/2013	Al-Ali et al.	8,840,549	B2	9/2014	Al-Ali et al.
8,489,364	B2	7/2013	Weber et al.	8,847,740	B2	9/2014	Kiani et al.
8,498,684	B2	7/2013	Weber et al.	8,849,365	B2	9/2014	Smith et al.
8,504,128	B2	8/2013	Blank et al.	8,852,094	B2	10/2014	Al-Ali et al.
8,509,867	B2	8/2013	Workman et al.	8,852,994	B2	10/2014	Wojtczuk et al.
8,515,509	B2	8/2013	Bruinsma et al.	8,868,147	B2	10/2014	Stippick et al.
8,523,781	B2	9/2013	Al-Ali	8,868,150	B2	10/2014	Al-Ali et al.
8,529,301	B2	9/2013	Al-Ali et al.	8,870,792	B2	10/2014	Al-Ali et al.
8,532,727	B2	9/2013	Ali et al.	8,886,271	B2	11/2014	Kiani et al.
8,532,728	B2	9/2013	Diab et al.	8,888,539	B2	11/2014	Al-Ali et al.
D692,145	S	10/2013	Al-Ali et al.	8,888,708	B2	11/2014	Diab et al.
8,547,209	B2	10/2013	Kiani et al.	8,892,180	B2	11/2014	Weber et al.
8,548,548	B2	10/2013	Al-Ali	8,897,847	B2	11/2014	Al-Ali
8,548,549	B2	10/2013	Schurman et al.	8,909,310	B2	12/2014	Lamego et al.
8,548,550	B2	10/2013	Al-Ali et al.	8,911,377	B2	12/2014	Al-Ali
8,560,032	B2	10/2013	Al-Ali et al.	8,912,909	B2	12/2014	Al-Ali et al.
8,560,034	B1	10/2013	Diab et al.	8,920,317	B2	12/2014	Al-Ali et al.
8,570,167	B2	10/2013	Al-Ali	8,921,699	B2	12/2014	Al-Ali et al.
8,570,503	B2	10/2013	Vo et al.	8,922,382	B2	12/2014	Al-Ali et al.
8,571,617	B2	10/2013	Reichgott et al.	8,929,964	B2	1/2015	Al-Ali et al.
8,571,618	B1	10/2013	Lamego et al.	8,942,777	B2	1/2015	Diab et al.
8,571,619	B2	10/2013	Al-Ali et al.	8,948,834	B2	2/2015	Diab et al.
8,577,431	B2	11/2013	Lamego et al.	8,948,835	B2	2/2015	Diab
8,581,732	B2	11/2013	Al-Ali et al.	8,965,471	B2	2/2015	Lamego
8,584,345	B2	11/2013	Al-Ali et al.	8,983,564	B2	3/2015	Al-Ali
8,588,880	B2	11/2013	Abdul-Hafiz et al.	8,989,831	B2	3/2015	Al-Ali et al.
8,600,467	B2	12/2013	Al-Ali et al.	8,996,085	B2	3/2015	Kiani et al.
8,606,342	B2	12/2013	Diab	8,998,809	B2	4/2015	Kiani
8,626,255	B2	1/2014	Al-Ali et al.	9,028,429	B2	5/2015	Telfort et al.
8,630,691	B2	1/2014	Lamego et al.	9,037,207	B2	5/2015	Al-Ali et al.
8,634,889	B2	1/2014	Al-Ali et al.	9,060,721	B2	6/2015	Reichgott et al.
8,641,631	B2	2/2014	Sierra et al.	9,066,666	B2	6/2015	Kiani
8,652,060	B2	2/2014	Al-Ali	9,066,680	B1	6/2015	Al-Ali et al.
8,663,107	B2	3/2014	Kiani	9,072,474	B2	7/2015	Al-Ali et al.
8,666,468	B1	3/2014	Al-Ali	9,078,560	B2	7/2015	Schurman et al.
8,667,967	B2	3/2014	Al-Ali et al.	9,084,569	B2	7/2015	Weber et al.
8,670,811	B2	3/2014	O'Reilly	9,095,316	B2	8/2015	Welch et al.
8,670,814	B2	3/2014	Diab et al.	9,106,038	B2	8/2015	Telfort et al.
8,676,286	B2	3/2014	Weber et al.	9,107,625	B2	8/2015	Telfort et al.
8,682,407	B2	3/2014	Al-Ali	9,107,626	B2	8/2015	Al-Ali et al.
RE44,823	E	4/2014	Parker	9,113,831	B2	8/2015	Al-Ali
RE44,875	E	4/2014	Kiani et al.	9,113,832	B2	8/2015	Al-Ali
8,690,799	B2	4/2014	Telfort et al.	9,119,595	B2	9/2015	Lamego
				9,131,881	B2	9/2015	Diab et al.
				9,131,882	B2	9/2015	Al-Ali et al.
				9,131,883	B2	9/2015	Al-Ali
				9,131,917	B2	9/2015	Telfort et al.

(56)

References Cited

U.S. PATENT DOCUMENTS

9,138,180 B1	9/2015	Coverston et al.	2013/0023775 A1	1/2013	Lamego et al.	
9,138,182 B2	9/2015	Al-Ali et al.	2013/0041591 A1	2/2013	Lamego	
9,138,192 B2	9/2015	Weber et al.	2013/0045685 A1	2/2013	Kiani	
9,142,117 B2	9/2015	Muhsin et al.	2013/0046204 A1	2/2013	Lamego et al.	
9,153,112 B1	10/2015	Kiani et al.	2013/0060147 A1	3/2013	Welch et al.	
9,153,121 B2	10/2015	Kiani et al.	2013/0096405 A1	4/2013	Garfio	
9,161,696 B2	10/2015	Al-Ali et al.	2013/0096936 A1	4/2013	Sampath et al.	
9,161,713 B2	10/2015	Al-Ali et al.	2013/0109935 A1	5/2013	Al-Ali et al.	
9,167,995 B2	10/2015	Lamego et al.	2013/0162433 A1	6/2013	Muhsin et al.	
9,176,141 B2	11/2015	Al-Ali et al.	2013/0190581 A1	7/2013	Al-Ali et al.	
9,186,102 B2	11/2015	Bruinsma et al.	2013/0197328 A1	8/2013	Diab et al.	
9,192,312 B2	11/2015	Al-Ali	2013/0211214 A1 *	8/2013	Olsen .....	A61B 5/742
9,192,329 B2	11/2015	Al-Ali	2013/0218596 A1 *	8/2013	Gome .....	600/316 G06Q 10/06 705/3
9,192,351 B1	11/2015	Telfort et al.	2013/0243021 A1	9/2013	Siskavich	
9,195,385 B2	11/2015	Al-Ali et al.	2013/0253334 A1	9/2013	Al-Ali et al.	
9,211,072 B2	12/2015	Kiani	2013/0274571 A1	10/2013	Diab et al.	
9,211,095 B1	12/2015	Al-Ali	2013/0296672 A1	11/2013	O'Neil et al.	
9,218,454 B2	12/2015	Kiani et al.	2013/0317370 A1	11/2013	Dalvi et al.	
9,226,696 B2	1/2016	Kiani	2013/0324808 A1	12/2013	Al-Ali et al.	
9,241,662 B2	1/2016	Al-Ali et al.	2013/0331670 A1	12/2013	Kiani	
9,245,668 B1	1/2016	Vo et al.	2013/0338461 A1	12/2013	Lamego et al.	
9,259,185 B2	2/2016	Abdul-Hafiz et al.	2014/0012100 A1	1/2014	Al-Ali et al.	
9,267,572 B2	2/2016	Barker et al.	2014/0025306 A1	1/2014	Weber et al.	
9,277,880 B2	3/2016	Poeze et al.	2014/0034353 A1	2/2014	Al-Ali et al.	
9,289,167 B2	3/2016	Diab et al.	2014/0051953 A1	2/2014	Lamego et al.	
9,295,421 B2	3/2016	Kiani et al.	2014/0058230 A1	2/2014	Abdul-Hafiz et al.	
9,307,928 B1	4/2016	Al-Ali et al.	2014/0066783 A1	3/2014	Kiani et al.	
9,323,894 B2	4/2016	Kiani	2014/0077956 A1	3/2014	Sampath et al.	
D755,392 S	5/2016	Hwang et al.	2014/0081100 A1	3/2014	Muhsin et al.	
9,326,712 B1	5/2016	Kiani	2014/0081175 A1	3/2014	Telfort	
9,333,316 B2	5/2016	Kiani	2014/0094667 A1	4/2014	Schurman et al.	
9,339,220 B2	5/2016	Lamego et al.	2014/0100434 A1	4/2014	Diab et al.	
9,341,565 B2	5/2016	Lamego et al.	2014/0114199 A1	4/2014	Lamego et al.	
9,351,673 B2	5/2016	Diab et al.	2014/0120564 A1	5/2014	Workman et al.	
9,351,675 B2	5/2016	Al-Ali et al.	2014/0121482 A1	5/2014	Merritt et al.	
9,364,181 B2	6/2016	Kiani et al.	2014/0121483 A1	5/2014	Kiani	
9,368,671 B2	6/2016	Wojtczuk et al.	2014/0127137 A1	5/2014	Bellott et al.	
9,370,325 B2	6/2016	Al-Ali et al.	2014/0128696 A1	5/2014	Al-Ali	
9,370,326 B2	6/2016	McHale et al.	2014/0128699 A1	5/2014	Al-Ali et al.	
9,370,335 B2	6/2016	Al-Ali et al.	2014/0129702 A1	5/2014	Lamego et al.	
9,375,185 B2	6/2016	Ali et al.	2014/0135588 A1	5/2014	Al-Ali et al.	
9,386,953 B2	7/2016	Al-Ali	2014/0142401 A1	5/2014	Al-Ali et al.	
9,386,961 B2	7/2016	Al-Ali et al.	2014/0142402 A1	5/2014	Al-Ali et al.	
9,392,945 B2	7/2016	Al-Ali et al.	2014/0163344 A1	6/2014	Al-Ali	
9,397,448 B2	7/2016	Al-Ali et al.	2014/0163402 A1	6/2014	Lamego et al.	
2006/0200009 A1 *	9/2006	Wekell et al. ....	2014/0166076 A1	6/2014	Kiani et al.	
2006/0282475 A1 *	12/2006	Suermondt ..... G06F 17/30286	2014/0171763 A1	6/2014	Diab	
2009/0247984 A1	10/2009	Lamego et al.	2014/0180038 A1	6/2014	Kiani	
2009/0275844 A1	11/2009	Al-Ali	2014/0180154 A1	6/2014	Sierra et al.	
2010/0004518 A1	1/2010	Vo et al.	2014/0194709 A1	7/2014	Al-Ali et al.	
2010/0030040 A1	2/2010	Poeze et al.	2014/0194711 A1	7/2014	Al-Ali	
2010/0179394 A1 *	7/2010	Sohn .....	2014/0194766 A1	7/2014	Al-Ali et al.	
		A61B 5/00	2014/0206963 A1	7/2014	Al-Ali	
		600/301	2014/0213864 A1	7/2014	Abdul-Hafiz et al.	
2010/0261979 A1	10/2010	Kiani	2014/0243627 A1	8/2014	Diab et al.	
2011/0001605 A1	1/2011	Kiani et al.	2014/0266790 A1	9/2014	Al-Ali et al.	
2011/0077968 A1 *	3/2011	Kelly .....	2014/0275808 A1	9/2014	Poeze et al.	
		G06F 19/345	2014/0275835 A1	9/2014	Lamego et al.	
		705/3	2014/0275871 A1	9/2014	Lamego et al.	
2011/0082711 A1	4/2011	Poeze et al.	2014/0275872 A1	9/2014	Merritt et al.	
2011/0105854 A1	5/2011	Kiani et al.	2014/0275881 A1	9/2014	Lamego et al.	
2011/0208015 A1	8/2011	Welch et al.	2014/0288400 A1	9/2014	Diab et al.	
2011/0213212 A1	9/2011	Al-Ali	2014/0296664 A1	10/2014	Bruinsma et al.	
2011/0230733 A1	9/2011	Al-Ali	2014/0303520 A1	10/2014	Telfort et al.	
2011/0237911 A1	9/2011	Lamego et al.	2014/0309506 A1	10/2014	Lamego et al.	
2012/0059267 A1	3/2012	Lamego et al.	2014/0316228 A1	10/2014	Blank et al.	
2012/0116175 A1	5/2012	Al-Ali et al.	2014/0323825 A1	10/2014	Al-Ali et al.	
2012/0179006 A1	7/2012	Jansen et al.	2014/0330092 A1	11/2014	Al-Ali et al.	
2012/0209082 A1	8/2012	Al-Ali	2014/0330098 A1	11/2014	Merritt et al.	
2012/0209084 A1	8/2012	Olsen et al.	2014/0330099 A1	11/2014	Al-Ali et al.	
2012/0227739 A1	9/2012	Kiani	2014/0333440 A1	11/2014	Kiani	
2012/0283524 A1	11/2012	Kiani et al.	2014/0336481 A1	11/2014	Shakespeare et al.	
2012/0296178 A1	11/2012	Lamego et al.	2014/0343436 A1	11/2014	Kiani	
2012/0304110 A1 *	11/2012	Chmiel .....	2015/0018650 A1	1/2015	Al-Ali et al.	
		G06F 3/0481	2015/0351697 A1	12/2015	Weber et al.	
		715/784	2015/0351704 A1	12/2015	Kiani et al.	
2012/0319816 A1	12/2012	Al-Ali	2015/0359429 A1	12/2015	Al-Ali et al.	
2012/0330112 A1	12/2012	Lamego et al.				

(56)

**References Cited**

## U.S. PATENT DOCUMENTS

2015/0366472 A1 12/2015 Kiani  
 2015/0366507 A1 12/2015 Blank  
 2015/0374298 A1 12/2015 Al-Ali et al.  
 2015/0380875 A1 12/2015 Coverston et al.  
 2016/0000362 A1 1/2016 Diab et al.  
 2016/0007930 A1 1/2016 Weber et al.  
 2016/0029932 A1 2/2016 Al-Ali  
 2016/0029933 A1 2/2016 Al-Ali et al.  
 2016/0045118 A1 2/2016 Kiani  
 2016/0051205 A1 2/2016 Al-Ali et al.  
 2016/0058338 A1 3/2016 Schurman et al.  
 2016/0058347 A1 3/2016 Reichgott et al.  
 2016/0066823 A1 3/2016 Al-Ali et al.  
 2016/0066824 A1 3/2016 Al-Ali et al.  
 2016/0066879 A1 3/2016 Telfort et al.  
 2016/0072429 A1 3/2016 Kiani et al.  
 2016/0073967 A1 3/2016 Lamego et al.  
 2016/0081552 A1 3/2016 Wojtczuk et al.  
 2016/0095543 A1 4/2016 Telfort et al.

2016/0095548 A1 4/2016 Al-Ali et al.  
 2016/0103598 A1 4/2016 Al-Ali et al.  
 2016/0113527 A1 4/2016 Al-Ali  
 2016/0143548 A1 5/2016 Al-Ali  
 2016/0166183 A1 6/2016 Poeze et al.  
 2016/0166188 A1 6/2016 Bruinsma et al.  
 2016/0166210 A1 6/2016 Al-Ali  
 2016/0192869 A1 7/2016 Kiani et al.  
 2016/0196388 A1 7/2016 Lamego  
 2016/0197436 A1 7/2016 Barker et al.  
 2016/0213281 A1 7/2016 Eckerbom et al.

## OTHER PUBLICATIONS

Lorincz, Konrad, et al. "Sensor Networks for Emergency Response: Challenges and Opportunities." *Pervasive Computing*, IEEE 3.4 (2004): 16-23.\*  
 Gao, Tia, et al. "Wireless Medical Sensor Networks in Emergency Response: Implementation and Pilot Results." *Technologies for Homeland Security*, 2008 IEEE Conference on. IEEE, 2008.\*

\* cited by examiner

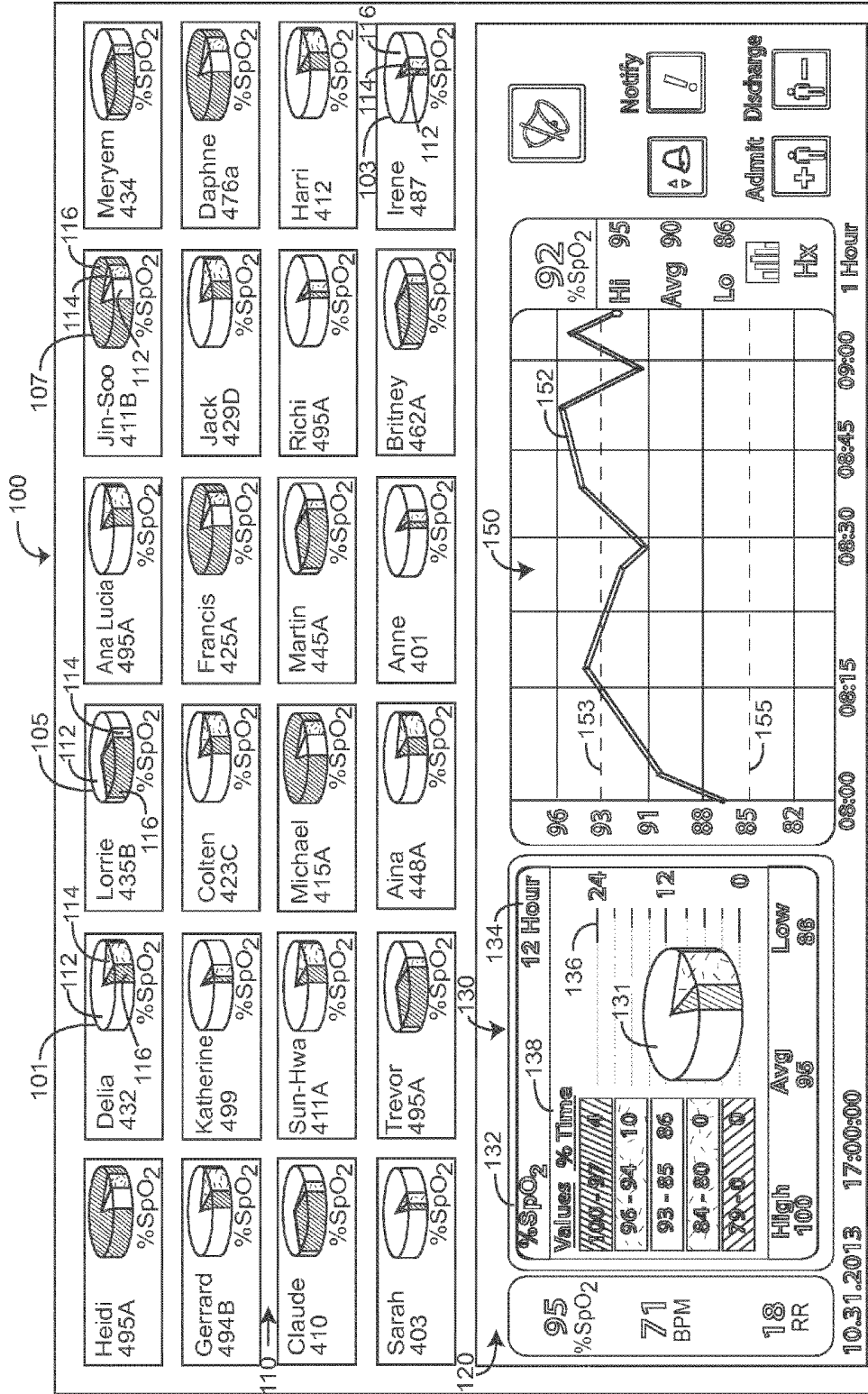

FIG. 1

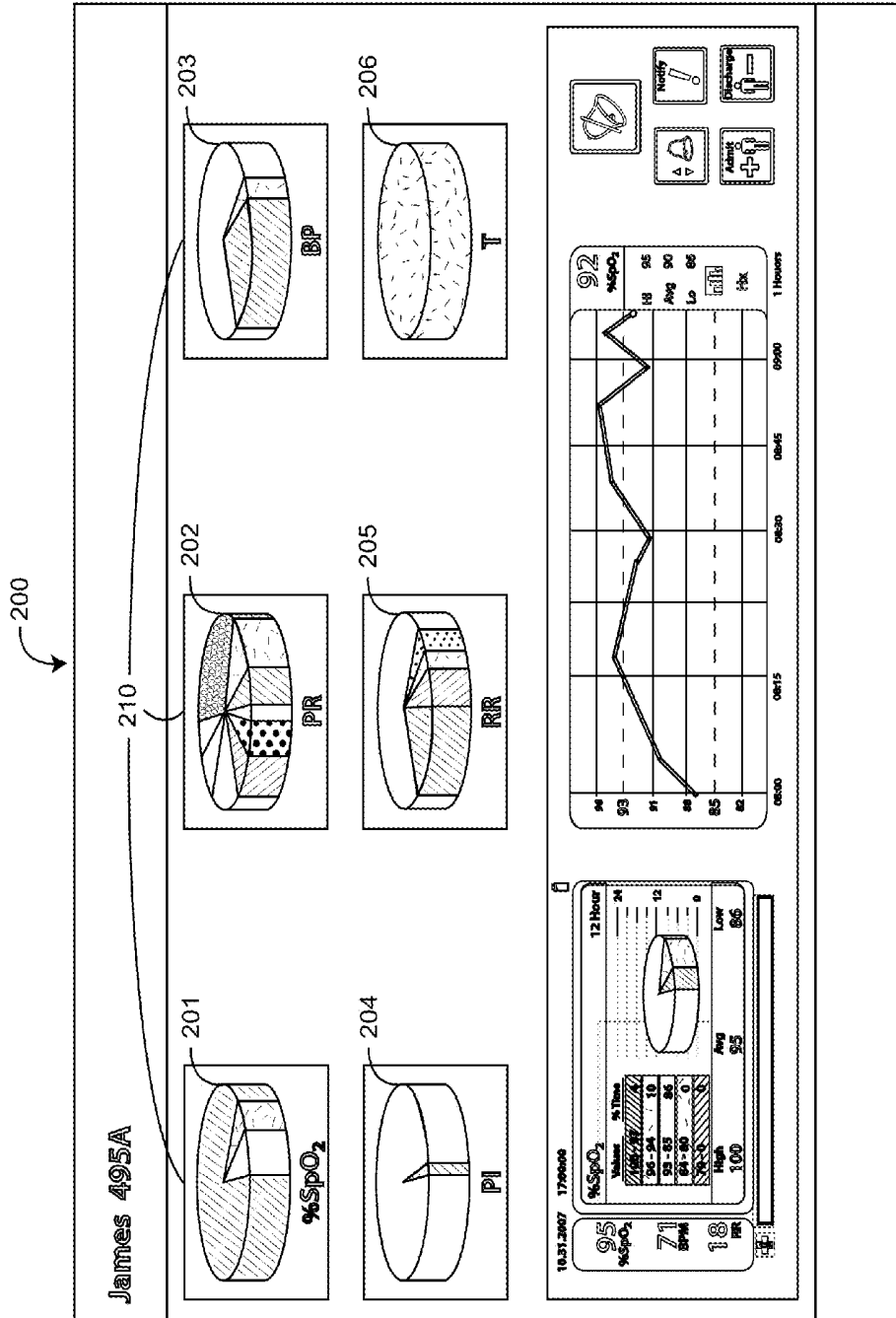

FIG. 2

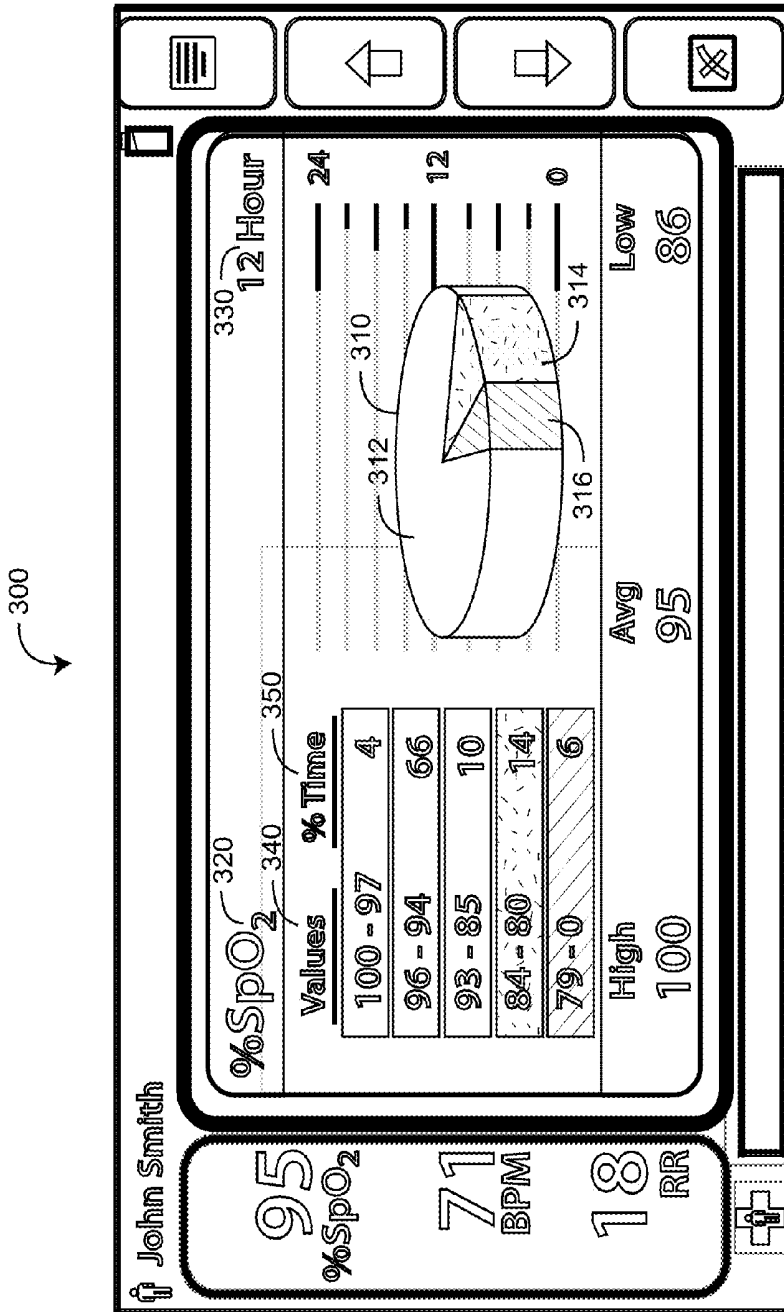

FIG. 3

301

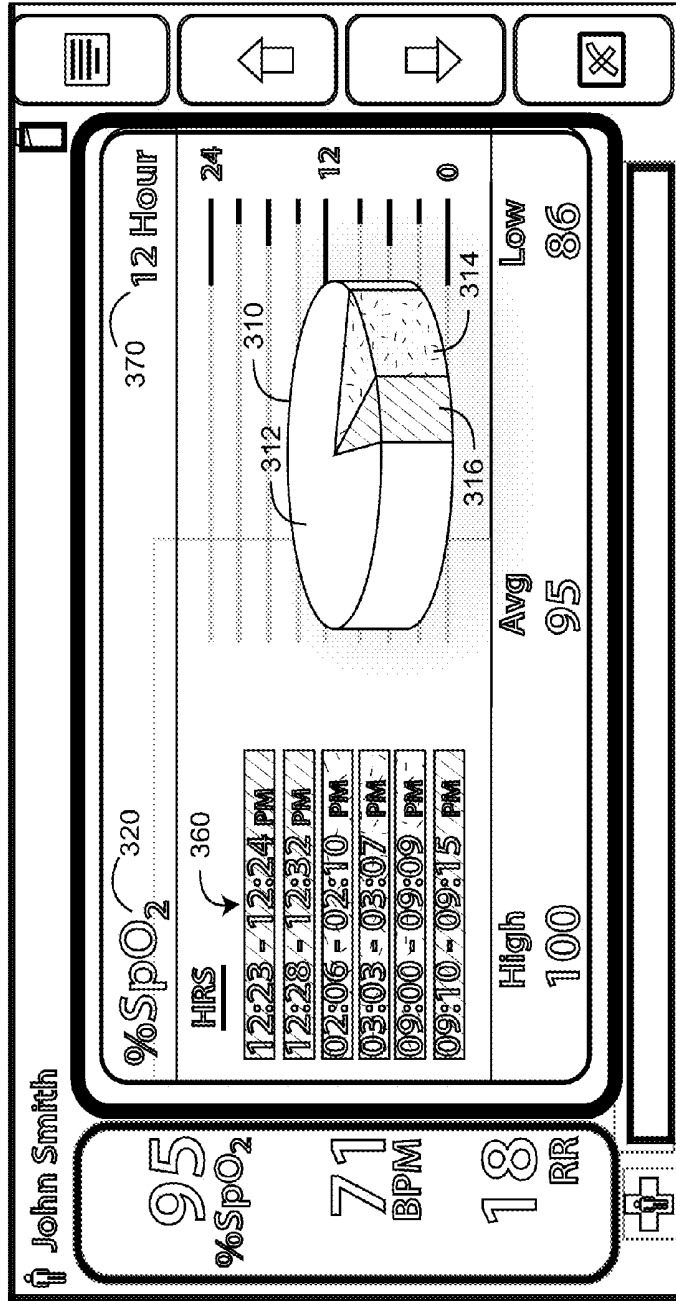

FIG. 4

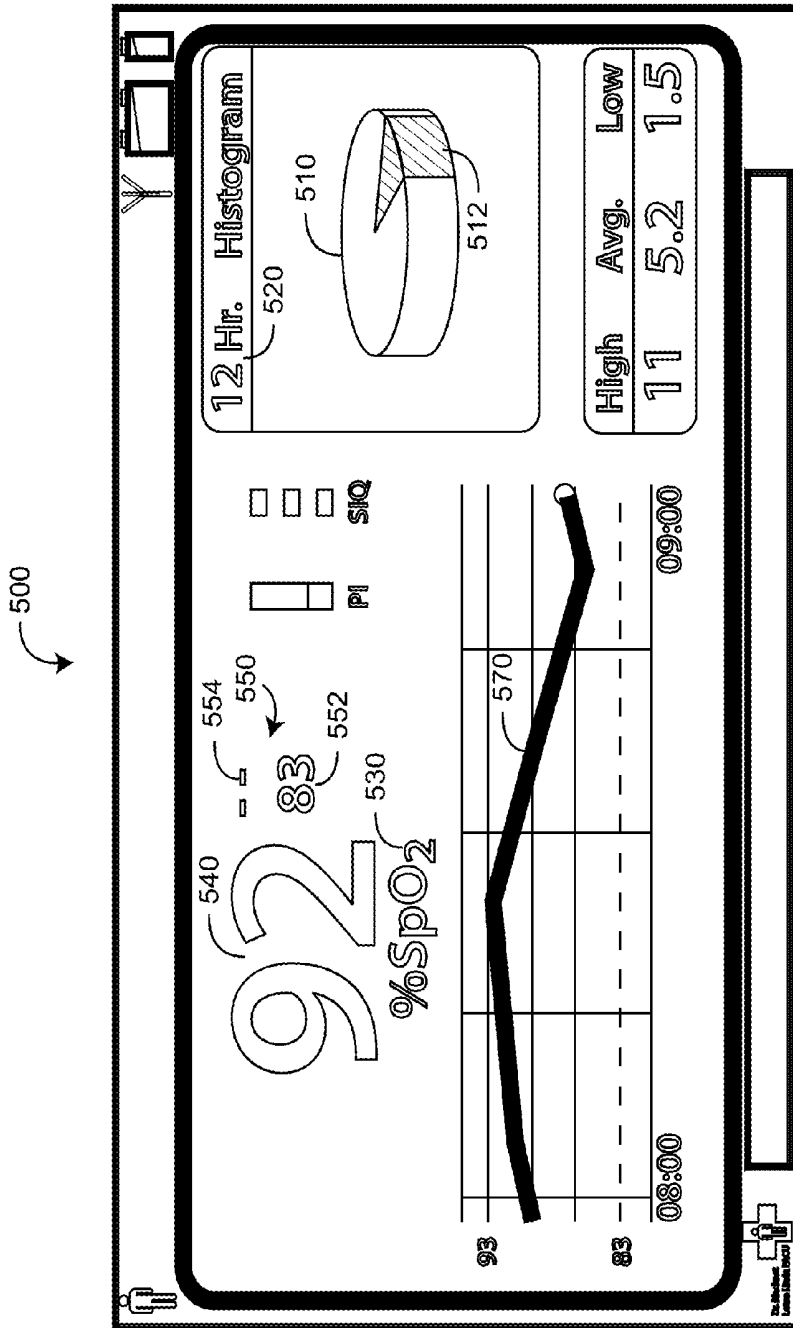

FIG. 5

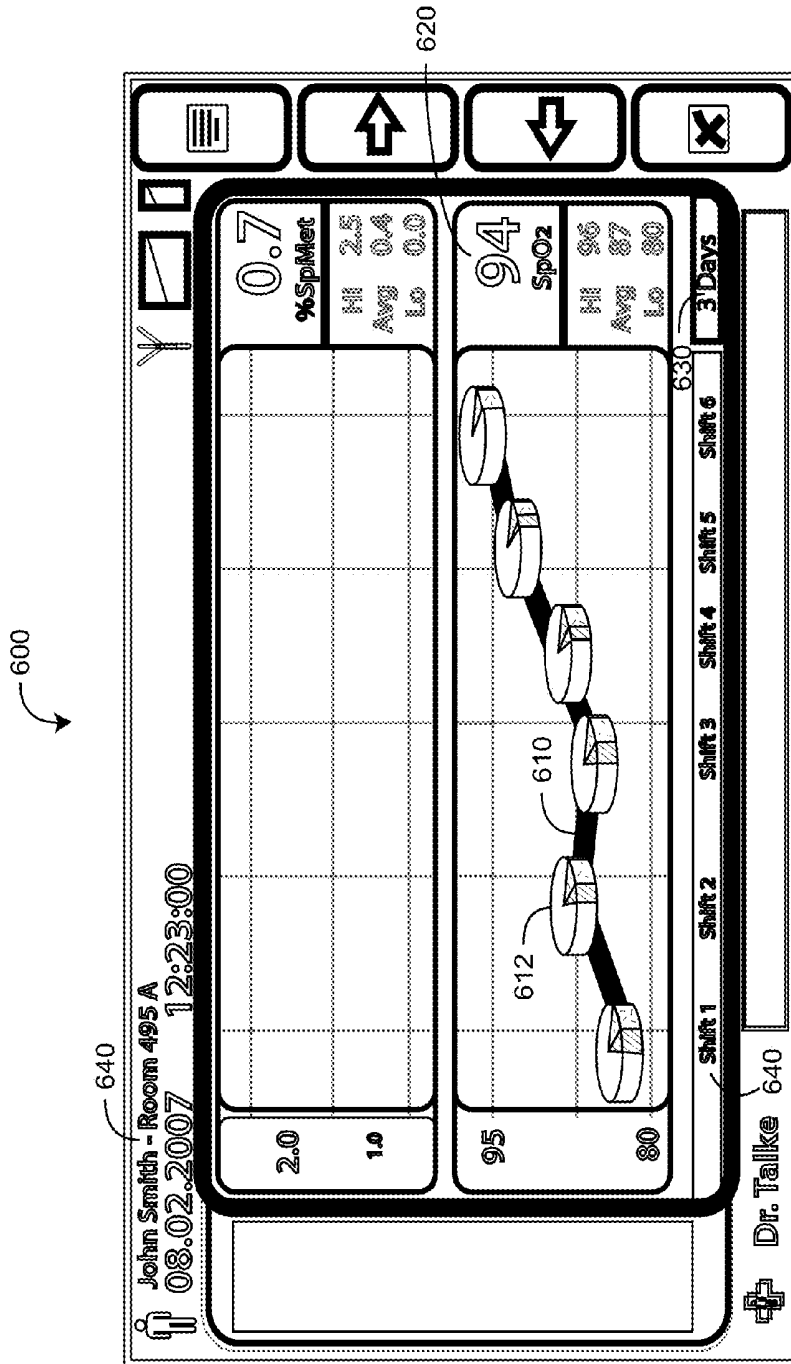

FIG. 6

700

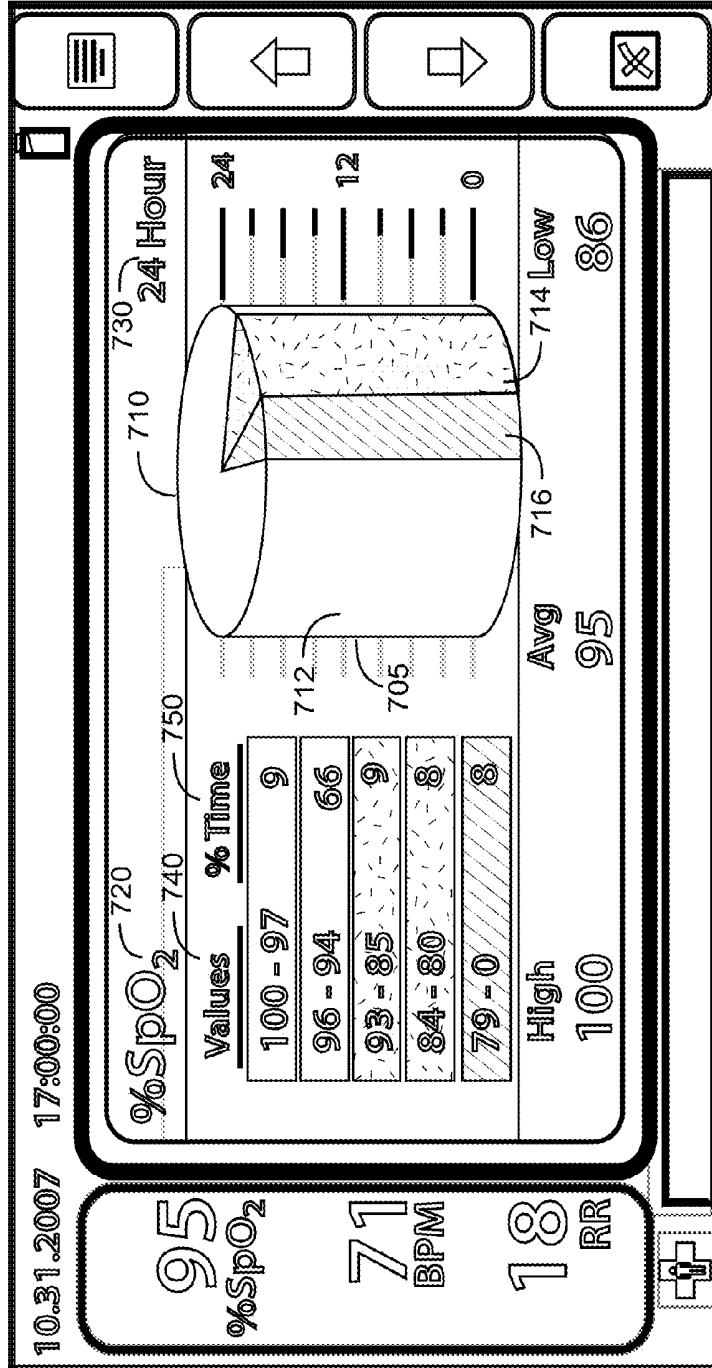
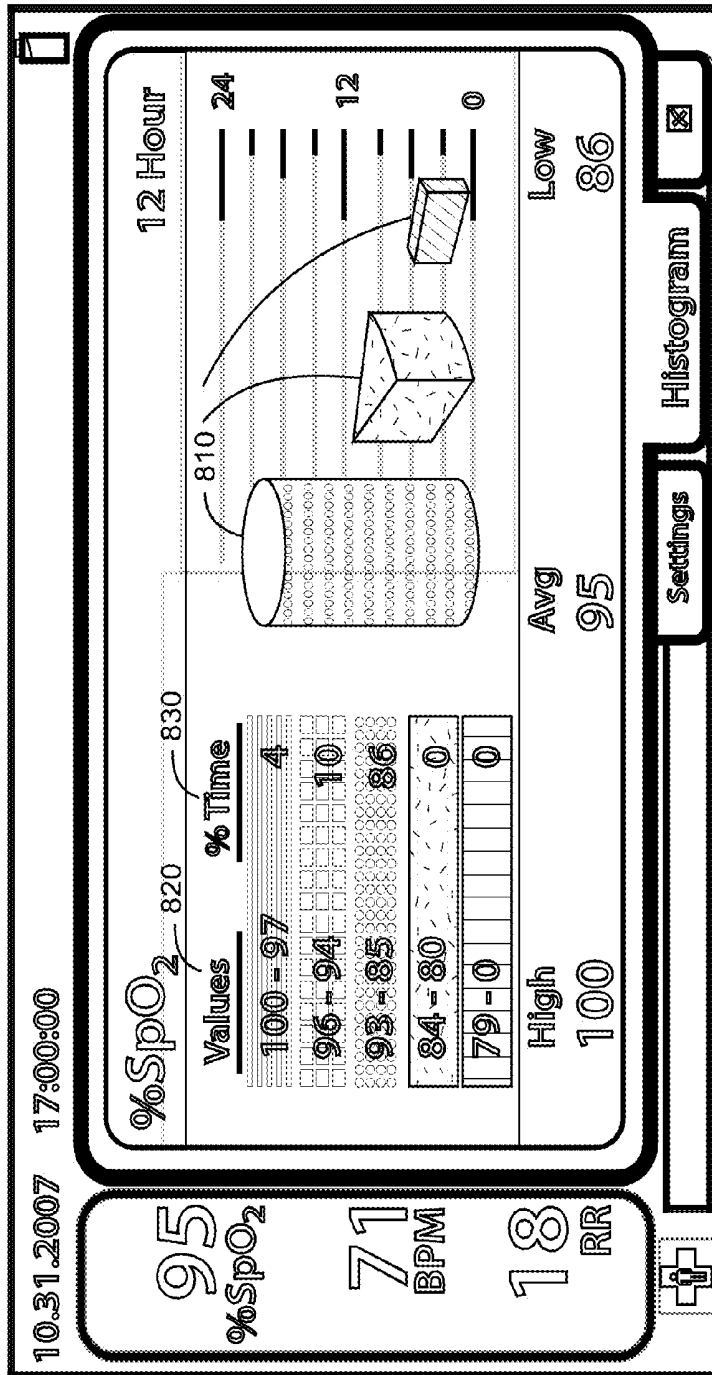

FIG. 7



800

FIG. 8

**PHYSIOLOGICAL STATUS MONITOR**PRIORITY CLAIM TO RELATED  
PROVISIONAL APPLICATION

The present application claims priority benefit under 35 U.S.C. §119(e) to U.S. Provisional Patent Application Ser. No. 61/775,568 filed Mar. 9, 2013, titled Physiological Status Monitor. The above-cited provisional patent application is hereby incorporated in its entirety by reference herein.

## BACKGROUND OF THE INVENTION

Pulse oximetry is a widely accepted noninvasive procedure for measuring the oxygen saturation level of arterial blood, an indicator of a person's oxygen supply. A typical pulse oximetry system utilizes an optical sensor attached to a fingertip to measure the relative volume of oxygenated hemoglobin in pulsatile arterial blood flowing within the fingertip. Oxygen saturation (SpO<sub>2</sub>), pulse rate and a plethysmograph waveform, which is a visualization of pulsatile blood flow over time, are displayed on a monitor accordingly.

Conventional pulse oximetry assumes that arterial blood is the only pulsatile blood flow in the measurement site. During patient motion, venous blood also moves, which causes errors in conventional pulse oximetry. Advanced pulse oximetry processes the venous blood signal so as to report true arterial oxygen saturation and pulse rate under conditions of patient movement. Advanced pulse oximetry also functions under conditions of low perfusion (small signal amplitude), intense ambient light (artificial or sunlight) and electrosurgical instrument interference, which are scenarios where conventional pulse oximetry tends to fail.

Advanced pulse oximetry is described in at least U.S. Pat. Nos. 6,770,028; 6,658,276; 6,157,850; 6,002,952; 5,769,785 and 5,758,644, which are assigned to Masimo Corporation ("Masimo") of Irvine, Calif. and are incorporated in their entirety by reference herein. Corresponding low noise optical sensors are disclosed in at least U.S. Pat. Nos. 6,985,764; 6,813,511; 6,792,300; 6,256,523; 6,088,607; 5,782,757 and 5,638,818, which are also assigned to Masimo and are also incorporated in their entirety by reference herein. Advanced pulse oximetry systems including Masimo SET® low noise optical sensors and read through motion pulse oximetry monitors for measuring SpO<sub>2</sub>, pulse rate (PR) and perfusion index (PI) are available from Masimo. Optical sensors include any of Masimo LNOP®, LNCS®, SofTouch™ and Blue™ adhesive or reusable sensors. Pulse oximetry monitors include any of Masimo Rad-8®, Rad-5®, Rad®-5v or SatShare® monitors.

Advanced blood parameter measurement systems are described in at least U.S. Pat. No. 7,647,083, filed Mar. 1, 2006, titled Multiple Wavelength Sensor Equalization; U.S. Pat. No. 7,729,733, filed Mar. 1, 2006, titled Configurable Physiological Measurement System; U.S. Pat. Pub. No. 2006/0211925, filed Mar. 1, 2006, titled Physiological Parameter Confidence Measure and U.S. Pat. Pub. No. 2006/0238358, filed Mar. 1, 2006, titled Noninvasive Multi-Parameter Patient Monitor, all assigned to Cercacor Laboratories, Inc., Irvine, Calif. (Cercacor) and all incorporated in their entirety by reference herein. Advanced blood parameter measurement systems include Masimo Rainbow® SET, which provides measurements in addition to SpO<sub>2</sub>, such as total hemoglobin (SpHb™), oxygen content (SpOC™), methemoglobin (SpMet®), carboxyhemoglobin (SpCO®)

and PVI®. Advanced blood parameter sensors include Masimo Rainbow® adhesive, ReSposable™ and reusable sensors. Advanced blood parameter monitors include Masimo Radical-7™, Rad-87™ and Rad-57™, Pronto-7® and Pronto® monitors, all available from Masimo. Such advanced pulse oximeters, low noise sensors and advanced blood parameter systems have gained rapid acceptance in a wide variety of medical applications, including surgical wards, intensive care and neonatal units, general wards, home care, physical training, and virtually all types of monitoring scenarios.

## SUMMARY OF THE INVENTION

Advantageously, a physiological status monitor provides information that allows a medical practitioner to visually discern patient condition at a glance. In an embodiment, a colored historical pie chart for a critical parameter, such as oxygen saturation, can be displayed for multiple patients. In another embodiment, multiple historical pie charts are displayed, depicting various parameters for a single patient so as to allow assessment of real time data and duration of time spent in various ranges. In particular, colored historical pie charts reflect visual representations of parameter histograms. Furthermore, colored pie charts may also represent alarm histories or medical personnel shifts.

One aspect of a physiological status monitor displays historical physical information of patients side by side, visually compares the information and identifies patients in need of immediate medical attention. In various embodiments, the display divides the information into medical conditions including a normal condition and a serious condition and distinguishes the conditions with indicators. Comparing may comprise viewing the indicators and discerning a serious condition with an indicator representing a particular serious condition. Identifying may comprise determining a patient having a high percentage of a serious condition indicator as the one in need of immediate medical attention. A particular condition may be oxygen saturation status. Distinguishing may comprise assigning colors to the conditions or assigning objects to the conditions.

Another aspect of a physiological status monitor is a monitor having an interconnected sensor. The sensor transmits optical radiation into a tissue site and generates a sensor signal responsive to the optical radiation after attenuation by pulsatile blood flow within the tissue site. The monitor computes a physiological parameter responsive to the sensor signal and utilizes a display to show the physiological parameter on screen. In an embodiment, the physiological status monitor comprises a monitor that determines a physiological parameter in response to an optical sensor signal derived from patients, a display incorporated with the monitor so as to present the physiological parameter, objects representing historical information regarding the physiological parameter over patients and a preferred screen presenting the objects side by side on the display for viewing by a caregiver so that the caregiver can visually discern and readily identify patients in need of immediate medical attention.

In various embodiments, the objects are colored pie charts. Each of the pie charts have zones representing different medical conditions, wherein the zones are assigned colors to make a visual distinction. The physiological parameter is oxygen saturation. The colors comprise a green color indicating a normal condition, an orange color indicating an abnormal condition and a red color indicating a serious condition, wherein a patient corresponding to one of

the pie charts having the most percentage of the red color is in need of a immediate medical attention. The objects are different shapes, wherein the shapes are filled in lines, dots, circle and square patterns to make a distinction for a color blind user.

As used herein the term "display" is used to denote how a monitor screen appears on a physical monitor device. The term "monitor" is used as shorthand for a monitor screen and its associated appearance to someone viewing a physical monitor.

#### BRIEF DESCRIPTION OF THE DRAWINGS

FIG. 1 is an illustration of a multiple-patient and a selected-patient physiological status monitor displaying a critical parameter, such as oxygen saturation, over time;

FIG. 2 is an illustration of a single-patient physiological status monitor displaying multiple parameters, such as oxygen saturation, pulse rate, blood pressure, perfusion index, respiration rate and temperature over time;

FIG. 3 is an illustration of a single-patient, single-parameter physiological status monitor displaying a parameter over time, where the pie chart colors correspond to assigned ranges for the parameter;

FIG. 4 is an illustration of a single-patient, single-parameter physiological status monitor displaying time intervals that correspond to pie chart segments;

FIG. 5 is an illustration of a single-patient, multiple-parameter physiological monitor displaying parameter alarm limits;

FIG. 6 is an illustration of a single-patient, single-parameter physiological status monitor displaying parameter trends having integrated pie-chart summaries at specific time intervals;

FIG. 7 is an illustration of a single-patient, single-parameter physiological status monitor displaying a pie-chart having a height that represents the total monitored time interval and pie slices that each represent the percentage of time a parameter is within the specified value range; and

FIG. 8 is an illustration of single-patient, single-parameter physiological status monitor displaying iconic patterns utilized in lieu of colors, such as for a color blind user, a monochromatic display or high contrast display applications.

#### DETAILED DESCRIPTION OF THE PREFERRED EMBODIMENTS

FIG. 1 illustrates a physiological status monitor 100 having a multiple-patient display 110 and a selected-patient display 120 of a critical parameter, such as oxygen saturation, over time. Historical information of a critical parameter over a duration of time is advantageously displayed for multiple patients simultaneously so as to allow a caregiver to visually discern and readily identify one or more patients in need of immediate medical attention. Advantageously, multiple colored historical pie charts 110 are advantageously utilized to represent the historical information. In an embodiment, each pie chart 110 has zones 112, 114, 116 representing the percentage of time a parameter has been measured in a particular range of values. Each zone 112, 114, 116 is assigned a different color indicating a different medical condition so that a relative comparison is made by simply viewing the size of a particular slice. For example, a pie chart 110 having a large red slice may indicate the corresponding patient has been experiencing difficulties and is in need of immediate medical attention.

As shown in FIG. 1, the exemplar parameter depicted in the pie charts 110 is oxygen saturation (SpO<sub>2</sub>). In other embodiments, the display 100 may depict any of various alternative parameters, such as those described above and with respect to FIG. 2, below. In an embodiment, each pie chart 110 has a first zone 112 assigned to a safe green color indicating a normal oxygen saturation condition, a second zone 114 assigned to an orange color indicating an abnormal oxygen saturation condition and a third zone 116 assigned to a warning red color indicating a serious oxygen saturation condition. A normal patient condition is advantageously identified when the first zone 112 (green) is the largest slice of a pie chart, with the second zone 114 (orange) and the third zone 116 (red) being significantly smaller slices, such as shown with respect to pie charts 101 and 103. That is, patients represented by the pie charts 101, 103 are in a normal condition over most of a specified time period, such as 12 hours.

Also shown in FIG. 1, an abnormal, but not serious, patient condition is advantageously identified when the third zone 116 (red) occupies a significant portion, but less than half, of a pie chart and the other zones 112, 114 combined occupy more than half of the pie chart. An example is pie chart 105, which a caregiver can readily identify at a glance as a patient needing an immediate medical assessment and further care.

Further shown in FIG. 1, a serious patient condition is advantageously identified when the third zone 116 (red) occupies most of the pie chart, and the other two zones 112, 114 combined occupy less of the pie chart than the third zone 116. As example is pie chart 107, which a caregiver can readily identify at a glance as a patient in distress and in need of emergency medical attention.

Additionally shown in FIG. 1, a selected-patient display 120 has a pie chart 130 mini screen and a graph 150 mini screen that provide more details regarding a selected patient than are available from the multiple patient display 110. In particular, the pie chart 130 mini screen shows details of a particular pie chart 131 including the critical parameter 132, a duration of time 134, a histogram 136 and range categories 138. The range categories 138 have predetermined value ranges and corresponding percentages of time that the selected parameter 132 spent in each range. Each range 138 is assigned to a color corresponding to that in the pie chart 130. The percentages of time spent in each range 138 over the specified time duration 134 is automatically tracked and displayed. In this manner, the details of one pie chart 131 can be viewed with respect to parameter ranges 138 that each color represents. For example, a green color in the pie chart 131 represents an SpO<sub>2</sub> range of 93-85, and the patient spent 86% of time spent in this range. An orange color represents an SpO<sub>2</sub> range of 96-94 and 84-80 and the patient spent 10% and 0% of the time in those ranges, respectively. A red color represents an SpO<sub>2</sub> range of 100-97 and 79-0 and the patient spent 4% and 0% of the time in those ranges, respectively.

Also shown in FIG. 1, the selected-patient display 120 has a graph mini-screen 150 showing further details of the pie chart 131. The graph mini-screen 150 has a graph 152 showing parameter values versus time over a period, an upper alarm limit 153 and a lower alarm limit 155. Thus, the specific times in an alarm state are illustrated.

FIG. 2 illustrates a single-patient physiological status monitor 200 displaying multiple parameters, such as oxygen saturation, pulse rate, blood pressure, perfusion index, respiration rate and temperature over time. Advantageously, the display 200 allows a caregiver to view multiple parameter histories side-by side in a visually-rich format. In this

manner, a caregiver can readily identify a patient having a serious medical condition or one incapable of adapting to a constantly changing medical environment. In particular, multiple-colored historical pie charts **210** are advantageously utilized to represent multiple parameters over time. Each colored pie chart **210** corresponds to a parameter and is a visual representation of the percentage of time spent in predetermined parameter ranges. Each range is assigned to a different color so that a serious medical condition can be rapidly discerned by simply comparing the multiplicity of the colors across the pie charts **210**. Specifically, pie charts **210** that have a rainbow of colors indicate physiological variability, which is a normal condition depending on the parameter. Pie charts **210** having only a single color, or just a few colors, indicate a patient that may not be adapting to their environment, which may indicate an abnormal condition depending on the parameter.

As shown in FIG. 2, the display **200** has multiple-colored pie charts **210** representing parameters over time. In this embodiment, a SpO<sub>2</sub> pie chart **201**, a pulse rate (PR) pie chart **202**, a blood pressure (BP) pie chart **203**, a perfusion index (PI) pie chart **204**, a respiration rate (RR) pie chart **205** and a temperature (T) pie chart **206** are shown. The PR pie chart **202** has a rainbow of colors showing that the patient's pulse rate is constantly varying over time and indicating the patient is adapting to a varying environment in this respect. The T pie chart **206** has only a single color showing the patient's temperature is constant. The pie charts SpO<sub>2</sub> **201**, BP **203**, PI **204** and RR **205** each has moderate color changes in between a rainbow style and a single color showing the measured parameters SpO<sub>2</sub>, BP, PI and RR are varying somewhat, but are not constantly varying over the monitored time duration. By viewing the color variety in pie charts **201-206**, the patient's condition may be determined as moderately good. Advantageously, the display of multiple parameters over time as colored pie charts may allow a ready determination of a patient's condition based upon color variability. If all or most of the pie charts **210** have a single color, the patient may have a serious condition in need of immediate medical attention.

FIGS. 3-4 illustrate a single-patient, single-parameter physiological status monitor **300, 301** displaying a parameter over time, where the pie chart colors correspond to assigned ranges for the parameter. The displays **300, 301** track a single parameter **320** for a single patient over a period of time and includes a pie chart **310**, a parameter indicator **320** and time duration **330**. The pie chart **310** has different zones **312, 314, 316** representing ranges of parameter values **340**. Each zone **312, 314, 316** is assigned a different color so as to be easily viewed by a user. The parameter indicator **320** indicates the particular parameter depicted in the charts, such as SpO<sub>2</sub>, HbCO, HbMet, Hbt, Hct, PI or PVI, to name a few.

As shown in FIG. 3, the single-patient, single parameter monitor **300, 301** has parameter value ranges **340** (FIG. 3) and the associated percentage of time **350** (FIG. 3) the parameter **320** spends in each range **340**. Each of the ranges **340** is assigned a corresponding color in the pie chart **310**. In this manner, the details of each zone (color) can be viewed. For example, a green zone **312** indicates a normal condition, i.e. SpO<sub>2</sub> in the range of 85-100%, an orange zone **314** indicates an abnormal condition, i.e. SpO<sub>2</sub> in the range of 84-80%, and a red zone **316** indicates a serious condition, i.e. SpO<sub>2</sub> below 79%.

As shown in FIG. 4, an alternative display **301** shows sequential time intervals **360** in the two unsafe zones **314, 316** of the pie chart **310**. These unsafe intervals **360** are

shown sequentially. When scrolled down, the display **360** shows all of the intervals in the two unsafe zones **314, 316** until reaching the total duration of time. The intervals **360** have colors corresponding to the colors in the two unsafe zones **314, 316** so as to provide the details of specific times spent in the unsafe zones. In another embodiment, the display **301** shows the longest intervals in the dangerous zone **316** of the pie chart **310**. By repeatedly clicking on the intervals, smaller intervals in the dangerous zone **316** are shown. In yet another embodiment, the display **301** shows intervals sequentially in all zones **312, 314, 316** of the pie chart **301**. The totality of intervals are shown by scrolling down the display **360** until the time duration **370** is displayed.

FIG. 5 illustrates a single-patient, multiple-parameter physiological monitor **500** displaying parameter alarm limits. The display **500** has a pie chart **510**, an indicator of duration of time **520**, a parameter value **540** and alarm limits **550**. The pie chart **510** has a zone **512** assigned in a distinct color, red, for example, representing a percentage of time in alarm during the duration of time. The alarm limits **550** are displayed next to the actual parameter value **540** having a lower limit **552** and an upper limit **554**. An alarm is activated when the limits **552, 554** are exceeded.

Also shown in FIG. 5, the display **500** has a graph **570** showing the parameter values versus time during the duration of time and thus the specific times in alarm are shown. By repeatedly clicking the graph **570**, the rest of the times can be shown until the end of the recorded time duration is reached. For example, FIG. 5 shows the lower limit **552** is **83** and no upper limit **554**. Because the graph **570** does not exceed the lower limit **83** between 8:00 to 9:00, no alarm is activated during this period of time. By clicking the graph **570**, other values and times in alarm will be shown until reaching the duration of 12 hours.

FIG. 6 illustrates a single-patient, single-parameter physiological status monitor **600** displaying parameter trends having integrated pie-chart summaries at specific time intervals. The display **600** has a trend line **610** with integrated pie-chart summaries **612** at specific time intervals. The display **600** also has a parameter indicator **620**, a duration of time **630** and a shift timeline **640**. The parameter indicator **620** corresponds to the trend line **610** and pie chart summaries **612**. The duration of time **630** is the duration of the trend line **610**. The trend line **610** has a plurality of pie charts **612** indicating a patient's parameter levels for each of the shifts over the shift duration. This trend line **610** advantageously provides an overview of each staff shift with respect to difficulty or success in patient management. In particular, the trend line **610** indicates acceptable levels of patient condition during each staff shift. This provides hospital or a medical institution feedback of medical care efficacy. For example, the monitor **600** advantageously provides information regarding which shift is maintaining the better patient management and which staff members are maintaining better patient management.

As shown in FIG. 6 as an example, six shifts and associated pie charts are displayed **600**. Shift 3 had difficulty with this patient. However, the patient improved over his three day stay across the different shifts.

FIG. 7 illustrates a single-patient, single-parameter physiological status monitor **700** has a pie chart **710**, a parameter indicator **720** and a duration of time indicator **730**. The pie-chart **710** has a height **705** that represents the total monitored time interval and pie slices **712, 714, 716** that each represent the percentage of time **750** a parameter is within the specified value range **740**. The pie chart **710** is a

histogram over a duration of time **730**, such as 24 hours. The pie chart **710** has different zones **712**, **714**, **716** indicating percentage of time **750** spent in each of the different value ranges **740**. Each zone **712**, **714**, **716** is assigned to a different color so as to be easily viewed by a user to determine, at a glance, an overview of a patient's condition over a time interval.

For example, in the pie chart **710**, a safe green color **712** indicates a normal condition occurring 75% of the time. An orange color **714** indicates an abnormal condition occurring 17% of the time. A red color **716** indicates a dangerous condition occurring 8% of the time. Accordingly, the details of the pie chart **710** are viewed in the range chart **740**, **750** showing 9% of time spent in a SpO<sub>2</sub> range of 100-97, 66% of time spent in a range of 96-94, 9% in a range of 93-95, 8% in a range 84-80 and 8% in a range of 79-0.

FIG. **8** illustrates a single-patient, single-parameter physiological status monitor **800** displaying iconic patterns utilized in lieu of colors, such as for a color blind user, a monochromatic display or a high contrast display. The display **800** has different shapes **810** representing percentages of time in each condition instead of a pie chart. Further, each shape **810** has lines, dots, circle patterns to distinguish each other rather than different colors assigned in a pie chart. Accordingly, value ranges **820** and percentages of time **830** have corresponding lines, dots, circle and square patterns, instead of different colors, assigned to each range.

A physiological status monitor has been disclosed in detail in connection with various embodiments. These embodiments are disclosed by way of examples only and are not to limit the scope of the claims that follow. One of ordinary skill in art will appreciate many variations and modifications.

What is claimed is:

1. A physiological status monitor responsive to an interconnected sensor, the sensor generates a sensor signal responsive to a physiological phenomenon and a display presents a measured physiological parameter responsive to the phenomenon, the physiological status monitor comprising:

a monitor configured to determine a physiological parameter in response to a sensor signal derived from a patient;

a single screen display incorporated with the monitor so as to display a summary screen corresponding to the physiological parameter;

a plurality of objects representing historical information regarding the physiological parameter for each of a plurality of patients;

the summary screen comprising the plurality of objects on the single screen display,

wherein each of the plurality of objects comprise a pie chart including:

a first zone representing a first combined amount of time the physiological parameter is within a first range of values over a monitored time period; and

a second zone representing a second combined amount of time the physiological parameter is within a second range of values different than the first range of values over the monitored time period, and wherein a ratio of a first display portion associated with the first zone to a second display portion associated with the second zone in each of the plurality of objects is based at least in part on the first combined amount of time, the second combined amount of time, and the monitored time period;

the single screen display further configured to display a selected patient screen simultaneously with the summary screen, the selected patient screen including patient visualization of a selected patient from the plurality of patients,

the patient visualization comprising:

a first axis corresponding to a time scale, said time scale divided into a plurality of time periods;

a second axis correspond to a physiological parameter scale;

a first plot representing a trend of the physiological parameter of the selected patient as with respect to the first axis and the second axis;

a second plot representing an alarm limit corresponding to the physiological parameter;

for each of the plurality of time periods:

a time period pie chart representing a time summary of physiological parameter of the selected patient for the respective plurality of time periods, wherein the time period pie chart is integrated with the first plot and wherein the time period pie charts are connected by a line,

wherein the physiological parameter is oxygen saturation; and

the single screen display is further configured to display a multiple parameter screen for the selected patient, the multiple parameter screen comprising:

a perfusion index pie chart configured to display historical values of perfusion index of the selected patient over a plurality of perfusion index ranges, each of the plurality of perfusion index ranges including different colors; and

a pulse rate pie chart configured to display historical values of pulse rate of the selected patient over a plurality of pulse rate ranges, each of the plurality of pulse rate ranges including different colors.

2. The physiological status monitor according to claim 1, wherein the first display portion comprises a first color and the second display portion comprises a second color different from the first color.

3. The physiological status monitor according to claim 1, wherein the monitored time period comprises 12 hours.

\* \* \* \* \*

专利名称(译)	生理状态监测		
公开(公告)号	<a href="#">US9750442</a>	公开(公告)日	2017-09-05
申请号	US14/203524	申请日	2014-03-10
[标]申请(专利权)人(译)	梅西莫股份有限公司		
申请(专利权)人(译)	Masimo公司		
当前申请(专利权)人(译)	Masimo公司		
[标]发明人	OLSEN GREGORY A		
发明人	OLSEN, GREGORY A.		
IPC分类号	A61B5/145 A61B5/00		
CPC分类号	A61B5/14542 A61B5/743 A61B5/7275 A61B5/746		
优先权	61/775568 2013-03-09 US		
其他公开文献	US20150051462A1		
外部链接	<a href="#">Espacenet</a> <a href="#">USPTO</a>		

摘要(译)

生理状态监视器具有监视器和互连传感器，其产生传感器信号。监视器响应于传感器信号计算生理参数并相应地显示生理参数。在一个实施例中，监视器以累积饼图格式显示多个患者的生理参数信息，使得护理人员可以快速辨别并容易地识别需要立即就医的患者。

