



US 20180153426A1

(19) **United States**

(12) **Patent Application Publication**
Thakur et al.

(10) **Pub. No.: US 2018/0153426 A1**
(43) **Pub. Date: Jun. 7, 2018**

(54) **REPRESENTATION AND IDENTIFICATION OF ACTIVITY PATTERNS DURING ELECTRO-PHYSIOLOGY MAPPING USING VECTOR FIELDS**

A61B 5/042 (2006.01)
A61B 5/044 (2006.01)
A61B 5/0452 (2006.01)
A61B 5/00 (2006.01)
G06K 9/00 (2006.01)
A61B 18/14 (2006.01)
A61B 18/00 (2006.01)

(71) Applicant: **Boston Scientific Scimed Inc.**, Maple Grove, MN (US)

(72) Inventors: **Pramodsingh H. Thakur**, Woodbury, MN (US); **Shibaji Shome**, Arden Hills, MN (US); **Shantha Arcot-Krishnamurthy**, Sammamish, WA (US); **Allan C. Shuros**, St. Paul, MN (US); **Barun Maskara**, Princeton Jct, NJ (US); **Sunipa Saha**, Shoreview, MN (US)

(52) **U.S. Cl.**
CPC . *A61B 5/04011* (2013.01); *A61B 2018/00577* (2013.01); *A61B 5/0422* (2013.01); *A61B 5/044* (2013.01); *A61B 5/04525* (2013.01); *A61B 5/7246* (2013.01); *A61B 5/7221* (2013.01); *G06K 9/00496* (2013.01); *A61B 5/04012* (2013.01); *A61B 5/6852* (2013.01); *A61B 5/6858* (2013.01); *A61B 5/6859* (2013.01); *A61B 5/7203* (2013.01); *A61B 18/1492* (2013.01); *A61B 2018/00357* (2013.01); *A61B 5/04023* (2013.01)

(21) Appl. No.: **15/890,110**

(22) Filed: **Feb. 6, 2018**

Related U.S. Application Data

(63) Continuation of application No. 14/120,369, filed on May 14, 2014, now Pat. No. 9,918,649.
(60) Provisional application No. 61/823,386, filed on May 14, 2013.

Publication Classification

(51) **Int. Cl.**
A61B 5/04 (2006.01)
A61B 5/0402 (2006.01)

(57) **ABSTRACT**

A method and system for mapping an anatomical structure includes sensing activation signals of intrinsic physiological activity with a plurality of mapping electrodes disposed in or near the anatomical structure, each of the plurality of mapping electrodes having an electrode location. A vector field map which represents a direction of propagation of the activation signals at each electrode location is generated to identify a signature pattern and a location in the vector field map according to at least one vector field template. A target location of the identified signature pattern is identified according to a corresponding electrode location.

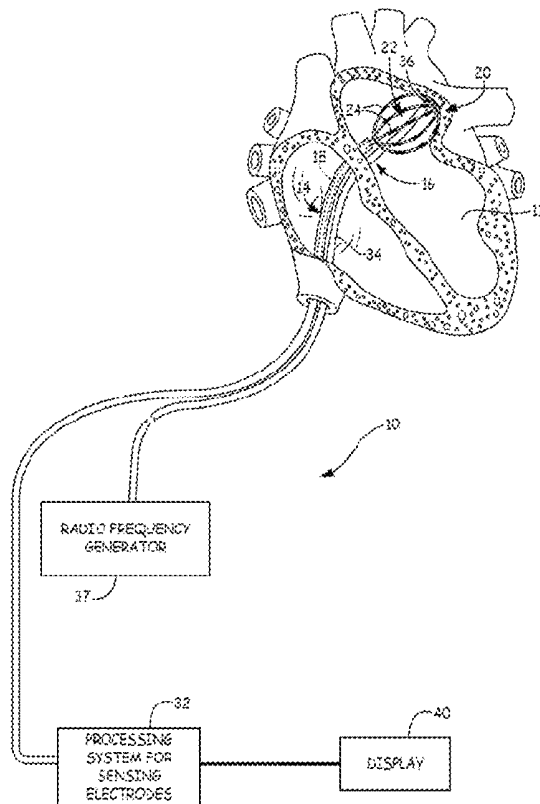
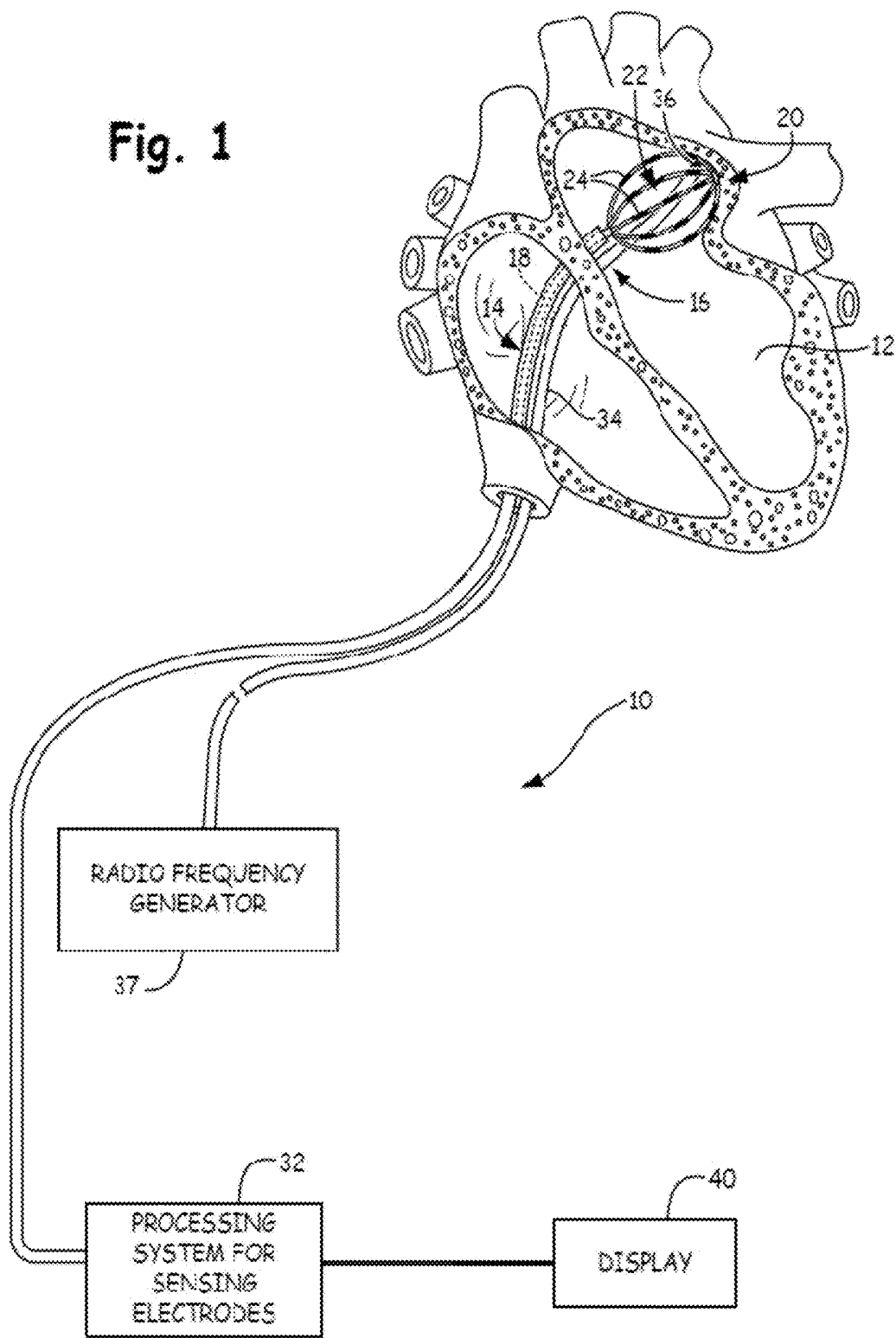

Fig. 1



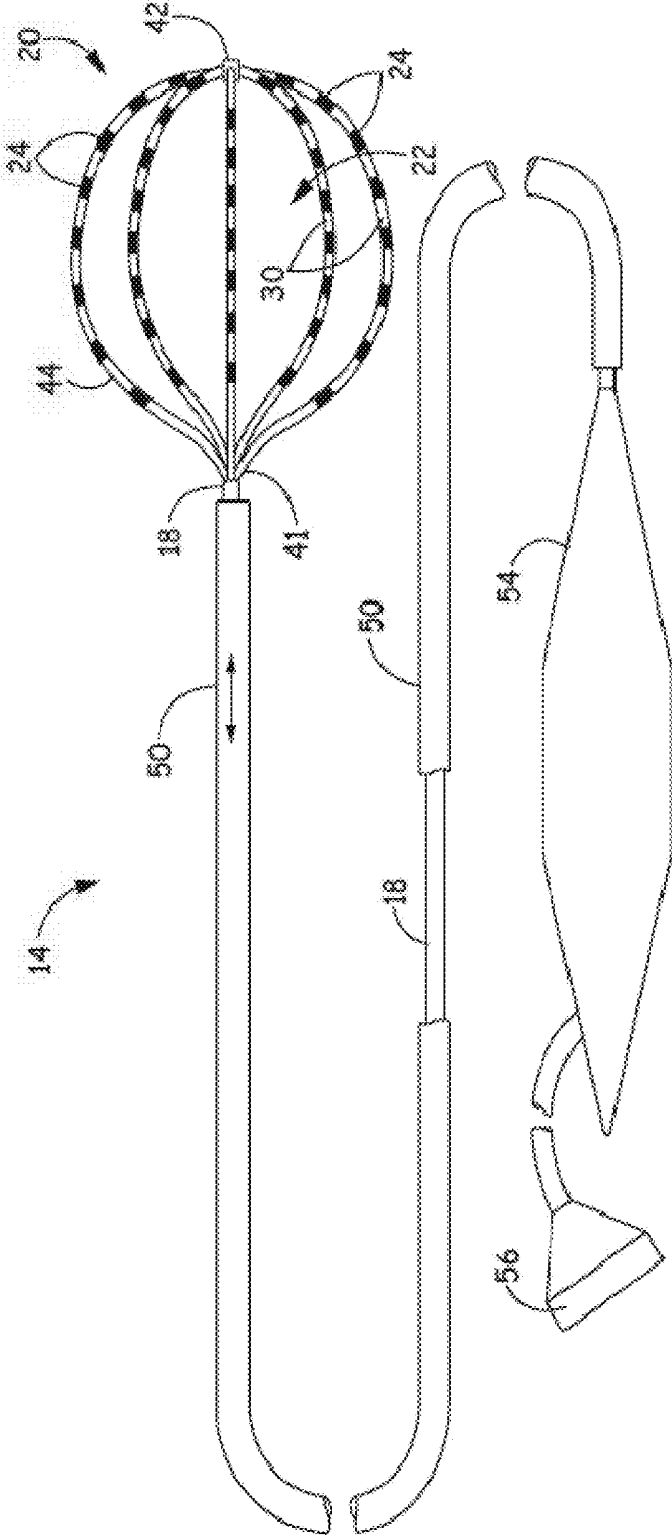

FIG. 2

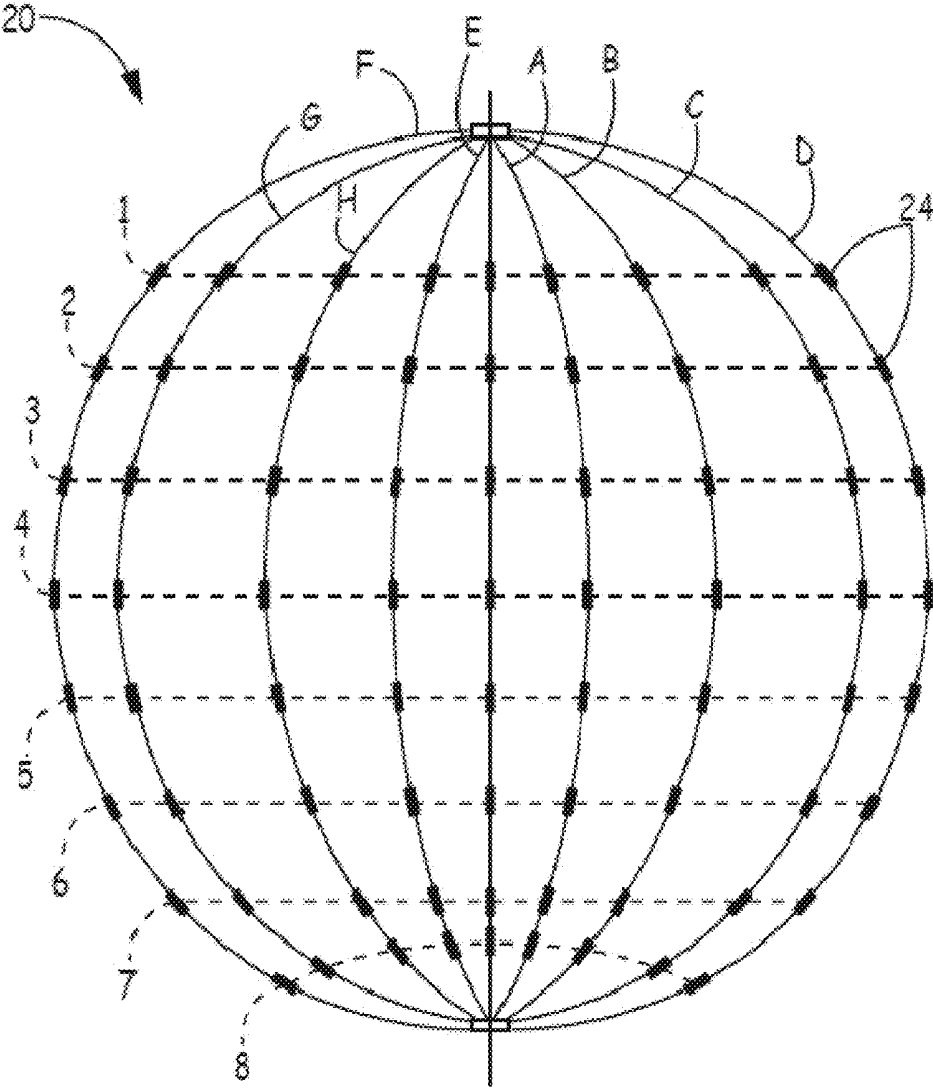

FIG. 3

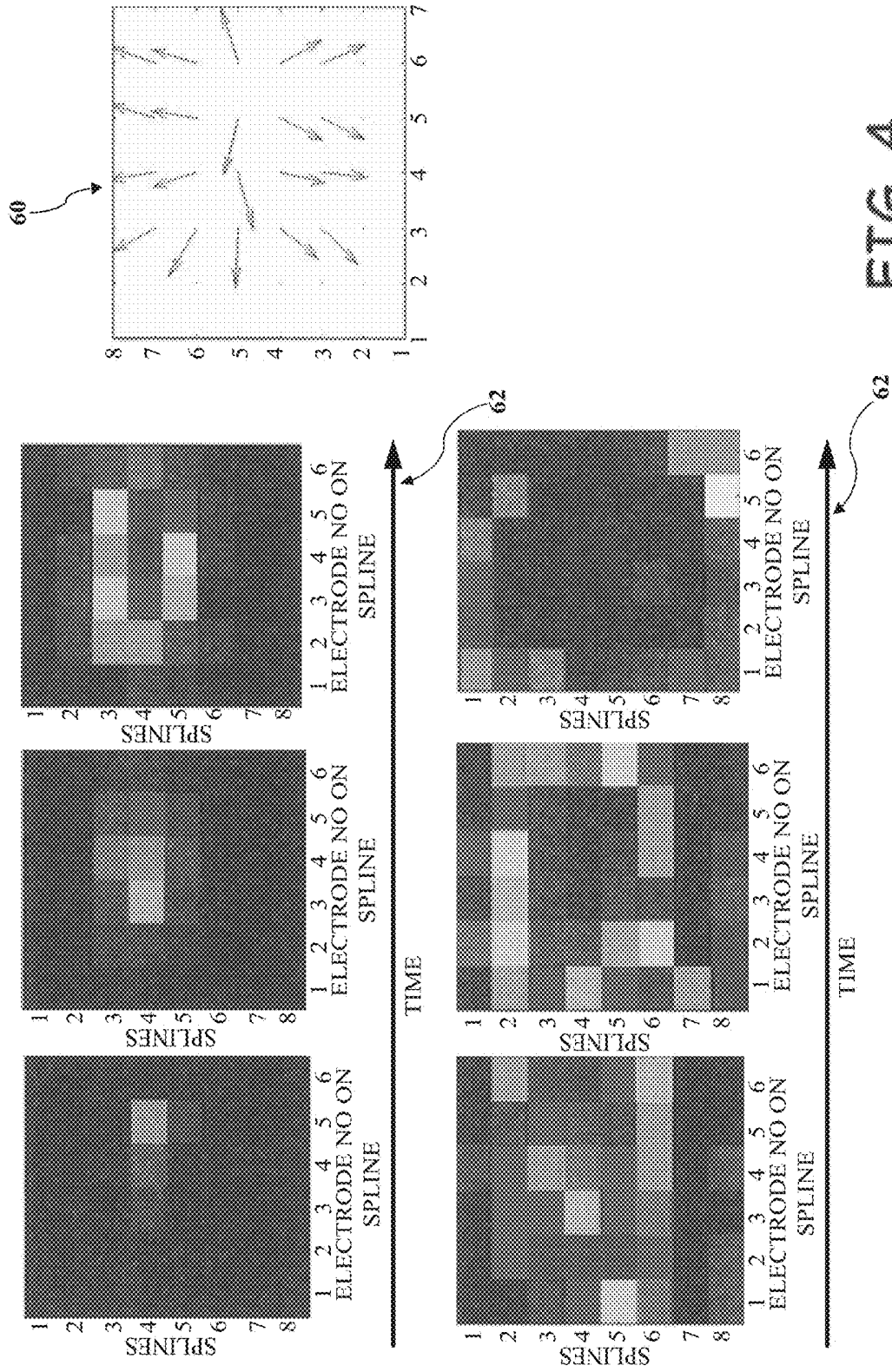
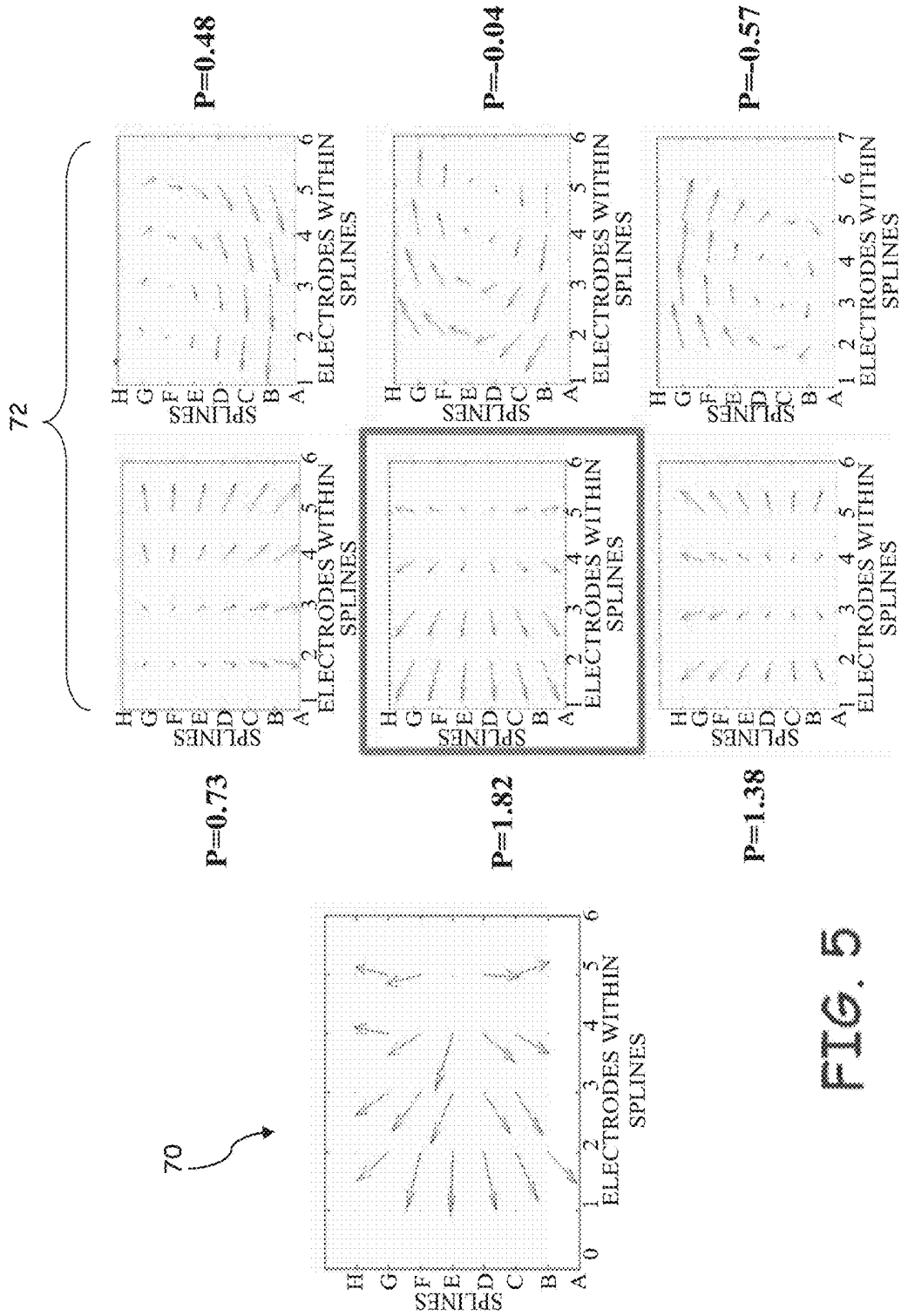

FIG. 4



**REPRESENTATION AND IDENTIFICATION
OF ACTIVITY PATTERNS DURING
ELECTRO-PHYSIOLOGY MAPPING USING
VECTOR FIELDS**

**CROSS-REFERENCE TO RELATED
APPLICATION**

[0001] This application is a continuation of U.S. application Ser. No. 14/120,369, filed May 14, 2014, which claims priority to Provisional Application No. 61/823,386, filed May 14, 2013, which is herein incorporated by reference in its entirety.

TECHNICAL FIELD

[0002] The present disclosure relates to cardiac mapping systems. More specifically, the present disclosure relates to a cardiac mapping system configured to display persistent data visualization during an electrophysiological study.

BACKGROUND

[0003] Diagnosing and treating heart rhythm disorders often involves the introduction of a catheter having a plurality of sensors/probes into a cardiac chamber through the surrounding vasculature. The sensors detect electric activity of the heart at sensor locations in the heart. The electric activity is generally processed into electrogram signals that represent signal propagation through cardiac tissue at the sensor locations.

[0004] Systems can be configured to display the electrical signals detected in the cardiac chamber as an activation map based on voltages detected. These activation maps may require interpolation of the detected voltages to get a finer scale of visualization across multiple electrodes of, for example, a basket catheter adapted for electrophysiological sensing. Furthermore, the decreased range of voltage signals can make automated pattern matching and classification challenging. Robust and reliable visualization of activation signals is paramount to identify accurate therapy targets during mapping. Therefore, it may be beneficial to provide a vector field pattern matching to identify aberrant electrical signals.

SUMMARY

[0005] In Example 1, a method for mapping an anatomical structure, the method includes sensing activation signals of intrinsic physiological activity with a plurality of mapping electrodes disposed in or near the anatomical structure, each of the plurality of mapping electrodes having an electrode location, generating a vector field map which represents a direction of propagation of the activation signals at each electrode location, identifying a signature pattern and a location in the vector field map according to at least one vector field template.

[0006] In Example 2, the method according to Example 1, wherein generating the vector field map further includes determining a vector of propagation at each electrode which represents a direction of propagation of the sensed activation signal with respect to at least one adjacent electrode.

[0007] In Example 3, the method according to either of Example 1 and 2, wherein generating the vector field map further includes determining a reliability index for each sensed activation signal at an electrode location according to at least one of a contact between the corresponding electrode

and the anatomical structure and a level of noise in the sensed activation signals, and scaling each vector of the vector field map according to the corresponding reliability index.

[0008] In Example 4, the method according to any one of Examples 1-3, wherein identifying the signature pattern further includes receiving a template bank which includes a plurality of vector field templates, each vector field template having a unique signature pattern, comparing the vector field map with each vector field template of the template bank, and identifying the signature pattern that most closely matches the generated vector field map according to a similarity index.

[0009] In Example 5, the method according to any one of Examples 1-4, wherein each unique signature pattern of the template bank includes at least one of a divergent pattern representing focal activity having a foci location and a curled pattern representing rotor activity having a core location.

[0010] In Example 6, the method according to any one of Examples 1-5, wherein comparing the vector field further includes determining a reliability index for each sensed activation signal at an electrode location according to at least one of a contact between the corresponding electrode and the anatomical structure and a level noise in the sensed activation signal, selecting one or more vectors of the vector field map which meet a preselected threshold based on the determined reliability index, and comparing only the one or more selected vectors with the corresponding vectors within each vector field template of the template bank.

[0011] In Example 7, the method according to Example 1, further includes displaying at least one of the generated vector field map and the identified target location.

[0012] In Example 8, a method for mapping cardiac tissue includes sensing activation signals of cardiac activity with a plurality of mapping electrodes disposed in or near the anatomical structure, each of the plurality of mapping electrodes having an electrode location, generating a vector field map which represents a direction of propagation of the activation signals at each electrode location and identifying a signature pattern and a location in the vector field map according to at least one vector field template.

[0013] In Example 9, the method according to Example 8, wherein generating the vector field map further includes determining a vector at each electrode which represents a direction of propagation of the sensed activation signal with respect to at least one adjacent electrode.

[0014] In Example 10, the method according to either of Examples 8-9, wherein generating the vector field map further includes determining a reliability index for each sensed activation signal at an electrode location based on at least one of a contact between the corresponding electrode and adjacent cardiac tissue and a level of noise in the sensed activation signal, and scaling each vector of the vector field map according to the corresponding reliability index.

[0015] In Example 11, the method according to any one of Examples 8-10, wherein identifying the signature pattern further includes receiving a template bank which includes a plurality of vector field templates, each vector field template having a unique signature pattern comparing the vector field map with each vector field template of the template bank, and identifying the signature pattern that most closely matches the generated vector field map according to a similarity index.

[0016] In Example 12, the method according to any one of Examples 8-11, wherein each unique signature pattern of the template bank includes at least one of a divergent pattern representing focal activity having a foci location and a curled pattern representing rotor activity having a core location.

[0017] In Example 13, the method according to any one of Examples 8-12, wherein comparing the vector field further includes determining a reliability index for each sensed activation signal at an electrode location according to a contact between the corresponding electrode and the anatomical structure selecting one or more vectors of the vector field map which meet a preselected threshold based on the determine reliability index, and compare only the one or more selected vectors with the corresponding vectors within each vector field template of the template bank.

[0018] In Example 14, a catheter system includes a plurality of mapping electrodes configured to detect activation signals of intrinsic cardiac activity, each of the plurality of mapping electrodes having an electrode location, and a mapping processor associated with the plurality of mapping electrodes, the mapping processor configured to record the detected activation signals and associate one of the plurality of mapping electrodes with each recorded activation signal, the mapping processor further configured to generate a vector field map which represents a direction of propagation of the activation signals at each electrode location, and identify a signature pattern and a location in the vector field map according to at least one vector field template.

[0019] In Example 15, the catheter system according to Example 14, wherein to generate the vector field map the processing system is further configured to determine a vector of propagation at each electrode which represents a direction of propagation of the sensed activation signal with respect to at least one adjacent electrode.

[0020] In Example 16, the catheter system according to either of Examples 14 and 15, wherein to generate the vector field map the processing system is further configured to determine a reliability index for each sensed activation signal at an electrode location according to at least one of a contact between the corresponding electrode and the anatomical structure and a level of noise in the sensed activation signal, and scale each vector of the vector field map according to the corresponding reliability index.

[0021] In Example 17, the catheter system according to any of Examples 14-16, wherein to identify the signature pattern the processing system is further configured to access a template bank which includes a plurality of vector field templates, each vector field template having a unique signature pattern, compare the vector field map with each vector field template of the template bank, and identify the signature pattern most closely matching the generated vector field map according to a similarity index.

[0022] In Example 18, the catheter system according to any one of Examples 14-17, wherein each unique signature pattern of the template bank includes at least one of a divergent pattern representing focal activity having a foci location and a curled pattern representing rotor activity having a core location.

[0023] In Example 19, the catheter system according to any one of Examples 14-18, wherein to compare the vector field the processing system is further configured to determine a reliability index for each sensed activation signal at an electrode location according to at least one of a contact

between the corresponding electrode and the anatomical structure and a level of noise in the sensed activation signal, select one or more vectors of the vector field map which meet a preselected threshold based on the determine reliability index, and compare only the one or more selected vectors with the corresponding vectors within each vector field template of the template bank.

[0024] In Example 20, the catheter system according to Example 14, further includes a display device for displaying at least one of the generated vector field map and the identified target location.

[0025] While multiple embodiments are disclosed, still other embodiments of the present invention will become apparent to those skilled in the art from the following detailed description, which shows and describes illustrative embodiments of the invention. Accordingly, the drawings and detailed description are to be regarded as illustrative in nature and not restrictive.

BRIEF DESCRIPTION OF THE DRAWINGS

[0026] FIG. 1 is a schematic view of an embodiment of a system for accessing a targeted tissue region in the body for diagnostic and therapeutic purposes.

[0027] FIG. 2 is a schematic view of an embodiment of a mapping catheter having a basket functional element carrying structure for use in association with the system of FIG. 1.

[0028] FIG. 3 is a schematic side view of an embodiment of the basket functional element including a plurality of mapping electrodes.

[0029] FIG. 4 illustrates a series of consecutive activation maps and a corresponding vector field map generated therefrom.

[0030] FIG. 5 illustrates a generated vector field map and a plurality of vector field templates employed by the processing system of FIG. 1.

[0031] While the invention is amenable to various modifications and alternative forms, specific embodiments have been shown by way of example in the drawings and are described in detail below. The intention, however, is not to limit the invention to the particular embodiments described. On the contrary, the invention is intended to cover all modifications, equivalents, and alternatives falling within the scope of the invention as defined by the appended claims.

DETAILED DESCRIPTION

[0032] FIG. 1 is a schematic view of a system 10 for accessing a targeted tissue region in the body for diagnostic or therapeutic purposes. FIG. 1 generally shows the system 10 deployed in the left atrium of the heart. Alternatively, system 10 can be deployed in other regions of the heart, such as the left ventricle, right atrium, or right ventricle. While the illustrated embodiment shows the system 10 being used for ablating myocardial tissue, the system 10 (and the methods described herein) may alternatively be configured for use in other tissue ablation applications, such as procedures for ablating tissue in the prostate, brain, gall bladder, uterus, and other regions of the body, including in systems that are not necessarily catheter-based.

[0033] The system 10 includes a mapping probe 14 and an ablation probe 16. In FIG. 1, each is separately introduced into the selected heart region 12 through a vein or artery

(e.g., the femoral vein or artery) through suitable percutaneous access. Alternatively, the mapping probe **14** and ablation probe **16** can be assembled in an integrated structure for simultaneous introduction and deployment in the heart region **12**.

[0034] The mapping probe **14** has a flexible catheter body **18**. The distal end of the catheter body **18** carries a three-dimensional multiple electrode structure **20**. In the illustrated embodiment, the structure **20** takes the form of a basket defining an open interior space **22** (see FIG. 2), although other multiple electrode structures could be used wherein the geometry of the electrode structure and electrode locations are known. The multiple electrode structure **20** carries a plurality of mapping electrodes **24** each having an electrode location and channel. Each electrode **24** is configured to sense intrinsic physiological activity in the anatomical region on which the ablation procedure is to be performed. In some embodiments, the electrodes **24** are configured to detect activation signals of the intrinsic physiological activity within the anatomical structure, e.g., the activation times of cardiac activity.

[0035] The electrodes **24** are electrically coupled to a processing system **32**. A signal wire (not shown) is electrically coupled to each electrode **24** on the basket structure **20**. The wires extend through the body **18** of the probe **14** and electrically couple each electrode **24** to an input of the processing system **32**, as will be described later in greater detail. The electrodes **24** sense intrinsic electrical activity in the anatomical region, e.g., myocardial tissue. The sensed activity, e.g. activation signals, is processed by the processing system **32** to assist the physician by generating an anatomical map, e.g., a vector field map, to identify the site or sites within the heart appropriate for ablation. The processing system **32** identifies a near-field signal component, i.e. activation signals associated with local activation and originating from the tissue adjacent to the mapping electrode **24**, from an obstructive far-field signal component, i.e. activation signals originating from non-adjacent tissue, within the sensed activation signals. For example, in an atrial study, the near-field signal component includes activation signals originating from atrial myocardial tissue whereas the far-field signal component includes activation signals originating from the ventricular myocardial tissue. The near-field activation signal component can be further analyzed to find the presence of a pathology and to determine a location suitable for ablation for treatment of the pathology, e.g., ablation therapy.

[0036] The processing system **32** includes dedicated circuitry (e.g., discrete logic elements and one or more microcontrollers; application-specific integrated circuits (ASICs); or specially configured programmable devices, such as, for example, programmable logic devices (PLDs) or field programmable gate arrays (FPGAs)) for receiving and/or processing the acquired activation signals. In some embodiments, the processing system **32** includes a general purpose microprocessor and/or a specialized microprocessor (e.g., a digital signal processor, or DSP, which may be optimized for processing activation signals) that executes instructions to receive, analyze and display information associated with the received activation signals. In such implementations, the processing system **32** can include program instructions, which when executed, perform part of the signal processing. Program instructions can include, for example, firmware, microcode or application code that is executed by micro-

processors or microcontrollers. The above-mentioned implementations are merely exemplary, and the reader will appreciate that the processing system **32** can take any suitable form.

[0037] In some embodiments, the processing system **32** may be configured to measure the intrinsic electrical activity in the myocardial tissue adjacent to the electrodes **24**. For example, in some embodiments, the processing system **32** is configured to detect intrinsic electrical activity associated with a dominant rotor or divergent activation pattern in the anatomical feature being mapped. Studies have shown that dominant rotors and/or divergent activation patterns have a role in the initiation and maintenance of atrial fibrillation, and ablation of the rotor path, rotor core, and/or divergent foci may be effective in terminating the atrial fibrillation. In either situation, the processing system **32** processes the sensed activation signals to generate a display of relevant characteristics, such as a voltage map, a vector field map, a contour map, a reliability map, an electrogram, and the like. The relevant characteristics may be used by the physician to identify a site suitable for ablation therapy.

[0038] The ablation probe **16** includes a flexible catheter body **34** that carries one or more ablation electrodes **36**. The one or more ablation electrodes **36** are electrically connected to a radio frequency generator (RF) **37** that is configured to deliver ablation energy to the one or more ablation electrodes **36**. The ablation probe **16** is movable with respect to the anatomical feature to be treated, as well as the structure **20**. The ablation probe **16** is positionable between or adjacent to electrodes **24** of the structure **20** as the one or more ablation electrodes **36** are positioned with respect to the tissue to be treated.

[0039] The processing system **32** outputs to a device **40** the display of relevant characteristics for viewing by a physician. In the illustrated embodiment, device **40** is a CRT, LED, or other type of display, or a printer). The device **40** presents the relevant characteristics in a format most useful to the physician. In addition, the processing system **32** may generate position-identifying output for display on the device **40** that aids the physician in guiding the ablation electrode(s) **36** into contact with tissue at the site identified for ablation.

[0040] FIG. 2 illustrates an embodiment of the mapping catheter **14** including electrodes **24** at the distal end suitable for use in the system **10** shown in FIG. 1. The mapping catheter **14** has a flexible catheter body **18**, the distal end of which carries the three dimensional structure **20** configured to carry the mapping electrodes or sensors **24**. The mapping electrodes **24** sense intrinsic electrical activity, e.g., activation signals, in the myocardial tissue, the sensed activity is then processed by the processing system **32** to assist the physician in identifying the site or sites having a heart rhythm disorder or other myocardial pathology via a generated and displayed relevant characteristics. This information can then be used to determine an appropriate location for applying appropriate therapy, such as ablation, to the identified sites, and to navigate the one or more ablation electrodes **36** to the identified sites.

[0041] The illustrated three-dimensional structure **20** comprises a base member **41** and an end cap **42** between which flexible splines **44** generally extend in a circumferentially spaced relationship. As discussed above, the three dimensional structure **20** takes the form of a basket defining an open interior space **22**. In some embodiments, the splines **44**

are made of a resilient inert material, such as Nitinol metal or silicone rubber, and are connected between the base member 41 and the end cap 42 in a resilient, pretensed condition, to bend and conform to the tissue surface they contact. In the illustrated embodiment, eight splines 44 form the three dimensional structure 20. Additional or fewer splines 44 could be used in other embodiments. As illustrated, each spline 44 carries eight mapping electrodes 24. Additional or fewer mapping electrodes 24 could be disposed on each spline 44 in other embodiments of the three dimensional structure 20. In the illustrated embodiment, the three dimensional structure 20 is relatively small (e.g., 40 mm or less in diameter). In alternative embodiments, the three dimensional structure 20 is even smaller or larger (e.g., 40 mm in diameter or greater).

[0042] A slidable sheath 50 is movable along the major axis of the catheter body 18. Moving the sheath 50 forward (i.e., toward the distal end) causes the sheath 50 to move over the three dimensional structure 20, thereby collapsing the structure 20 into a compact, low profile condition suitable for introduction into and/or removal from an interior space of an anatomical structure, such as, for example, the heart. In contrast, moving the sheath 50 rearward (i.e., toward the proximal end) exposes the three dimensional structure 20, allowing the structure 20 to elastically expand and assume the pretensed position illustrated in FIG. 2. Further details of embodiments of the three dimensional structure 20 are disclosed in U.S. Pat. No. 5,647,870, entitled "Multiple Electrode Support Structures," which is hereby expressly incorporated herein by reference in its entirety.

[0043] A signal wire (not shown) is electrically coupled to each mapping electrode 24. The wires extend through the body 18 of the mapping catheter 20 into a handle 54, in which they are coupled to an external connector 56, which may be a multiple pin connector. The connector 56 electrically couples the mapping electrodes 24 to the processing system 32. Further details on mapping systems and methods for processing signals generated by the mapping catheter are discussed in U.S. Pat. No. 6,070,094, entitled "Systems and Methods for Guiding Movable Electrode Elements within Multiple-Electrode Structure," U.S. Pat. No. 6,233,491, entitled "Cardiac Mapping and Ablation Systems," and U.S. Pat. No. 6,735,465, entitled "Systems and Processes for Refining a Registered Map of a Body Cavity," the disclosures of which are hereby expressly incorporated herein by reference.

[0044] It is noted that other multi-electrode structures could be deployed on the distal end of the mapping catheter 14. It is further noted that the multiple mapping electrodes 24 may be disposed on more than one structure rather than, for example, the single mapping catheter 14 illustrated in FIG. 2. For example, if mapping within the left atrium with multiple mapping structures, an arrangement comprising a coronary sinus catheter carrying multiple mapping electrodes and a basket catheter carrying multiple mapping electrodes positioned in the left atrium may be used. As another example, if mapping within the right atrium with multiple mapping structures, an arrangement comprising a decapolar catheter carrying multiple mapping electrodes for positioning in the coronary sinus, and a loop catheter carrying multiple mapping electrodes for positioning around the tricuspid annulus may be used.

[0045] Although the mapping electrodes 24 have been described as being carried by dedicated mapping probes, such as the mapping catheter 14, the mapping electrodes may be carried on non-mapping dedicated probes or multi-function probes. For example, an ablation catheter, such as the ablation catheter 16, can be configured to include one or more mapping electrodes 24 disposed on the distal end of the catheter body and coupled to the signal processing system 32 and guidance system (not shown). As another example, the ablation electrode at the distal end of the ablation catheter may be coupled to the signal processing system 32 to also operate as a mapping electrode.

[0046] To illustrate the operation of the system 10, FIG. 3 is a schematic side view of an embodiment of the basket structure 20 including a plurality of mapping electrodes 24. In the illustrated embodiment, the basket structure includes 64 mapping electrodes 24. The mapping electrodes 24 are disposed in groups of eight electrodes (labeled 1, 2, 3, 4, 5, 6, 7, and 8) on each of eight splines (labeled A, B, C, D, E, F, G, and H). While an arrangement of sixty-four mapping electrodes 24 is shown disposed on a basket structure 20, the mapping electrodes 24 may alternatively be arranged in different numbers, on different structures, and/or in different positions. In addition, multiple basket structures can be deployed in the same or different anatomical structures to simultaneously obtain signals from different anatomical structures.

[0047] After the basket structure 20 is positioned adjacent to the anatomical structure to be treated (e.g., left atrium or left ventricle of the heart), the processing system 32 is configured to record the activation signals from each electrode 24 channel related to intrinsic physiological activity of the anatomical structure, i.e. the electrodes 24 measure electrical activation signals intrinsic to the physiology of the anatomical structure.

[0048] In some embodiments, the processing system 32 is configured to identify signature patterns in generated vector field maps to locate a rotor activation pattern core or divergent activation pattern foci. With the core and/or foci location, a physician can direct a therapy device, e.g. an ablation catheter, to the identified core and/or foci location to administer the therapy at the corresponding tissue location. The vector field map 60, as illustrated in FIG. 4 (bottom), is a vector field wherein each vector represents a local direction of propagation of the activation signals sensed at each electrode 24 with respect to an adjacent or neighboring electrode 24 during a time period. FIG. 4 (top) illustrates an activation map 62 of an activation signal during atrial fibrillation propagating divergently from a focal point or foci. The processing system 32 senses the activation signals at an electrode location and determines an onset time associated with the activation signal at the current electrode location. To determine the vector corresponding to the propagating activation signal, the processing system 32 calculates a circular average of detected activation signals at adjacent or neighboring electrodes 24 according to latency between an activation signal sensed at a current electrode location and an activation signal sensed at a neighboring electrode location. In some embodiments, the processing system 32 determines each vector according to:

$$V = \arg(\sum_{\theta} (T_{\theta} - T_0) e^{-i\theta}) \quad \text{equation 1}$$

[0049] where T_0 is the onset time of an activation signal at a current electrode location, T_{θ} is the onset time of the

activation signal at a neighboring electrode location located at angle θ . The angle θ is based on the angle of the adjacent neighboring electrodes **24**. For example, eight neighboring electrodes **24** can be used to determine the vector for which

$$\theta = \left[0, \frac{\pi}{4}, \frac{\pi}{2}, \textcircled{2}\frac{\pi}{4}, \pi, \textcircled{2}\frac{\pi}{4}, \frac{3\pi}{2}, \frac{5\pi}{4} \right]$$

② indicates text missing or illegible when filed

To increase computational efficiency, four neighboring electrodes **24** can be employed for which

$$\theta = \left[0, \frac{\pi}{2}, \pi, \textcircled{2}\frac{\pi}{2} \right]$$

② indicates text missing or illegible when filed

where diagonal angles are excluded. Alternatively, the diagonal angles can be included instead for which

$$\theta = \left[\frac{\pi}{4}, \textcircled{2}\frac{\pi}{4}, \frac{3\pi}{4}, \textcircled{2}\frac{\pi}{4} \right]$$

② indicates text missing or illegible when filed

The processing system **32** can be configured to average the determined vector at each electrode location over a plurality of consecutive activation signals such that each vector is generated based on an average of a plurality of activation signals sensed over a selected time period.

[0050] In some embodiments, the processing system **32** generates a reliability index for each vector based on a contact between a mapping electrode **24** and the anatomical structure in contact with or directly adjacent to the corresponding electrode **24**. Surrogate measures such as impedance/conductance or signals from a force/strain sensors placed adjacent to the electrodes could be used to determine a good contact versus bad contact between the electrode and tissue. In some cases, in spite of good tissue contact it may be hard to reliably pick up activations due to noisy signal. Reliability index could quantify the level of noise on the signal using measures such as signal-to-noise ratio. The reliability index can then be used to modify each vector to convey the reliability visually to a user. For example, the line weight or color can be modified to illustrate the reliability such as a thicker line can be identified as a more reliable vector than a thinner line. Since, in a typical activation map the amplitude of the voltage at an electrode location is visualized by a varying color spectrum, the reliability index of the activation signal at the corresponding electrode location is difficult to incorporate into typical activation maps in addition to the voltage information.

[0051] In some embodiments, the processing system **32** is configured to determine a signature pattern for each vector field map. Each vector field map can be compared to one or more of a plurality of vector field templates which are stored within a template bank. The vector bank can be a database or an array or a plurality of vector templates that are stored locally in memory in the processing system **32** or can be

stored in a remote location and accessed via a network or internet connection. Each vector field template includes a vector field having a signature pattern and a location associated with the signature pattern. For example, the signature pattern may include patterns related to identifying a dominant rotor and/or divergent activation pattern associated with cardiac fibrillation. Each vector field template may include a unique signature pattern having an associated location wherein signature patterns include, for example, a curled pattern which can represent rotor activity including a rotor core and/or rotor path having a core location or a divergent pattern representing focal activity having a foci location.

[0052] FIG. 5 illustrates an example of a generated vector field map **70** and six vector field templates **72** to which the processing system **32** can compare the vector field map **70**. From vector field map **70**, the vectors illustrate a divergent pattern with a foci location centered approximately at spline E and electrode **5**. The processing system **32** can employ a distance based algorithm or a similarity based algorithm which will then compare each generated vector field to at least one of the vector field templates **72** in the template bank. The three templates **72** to the left illustrate divergent vector fields with foci locations centered in various positions, whereas the right three templates **72** illustrate curled vector fields with core locations at various positions. In some embodiments, the processing system **32** determines a similarity index P for each vector field template **72** based on a similarity algorithm applied to a generated vector field map. A vector field over N electrodes can be considered as a single “super-vector” in N×2 dimensional space. The index P is obtained by projecting the “super-vector” of the observed vector field onto a unit vector along the direction of the super-vector of the template vector field in the N×2 dimensional space. As illustrated in FIG. 5, the template **72** with P=1.82 has the highest similarity with generated vector field map **70**. The template associated with P=1.82 has a divergent pattern with a foci located between electrodes **4** & **5** between splines D & E which is very similar to the generated vector field map **70**. From the identified vector field template **72** and a foci location, the processing system **32** can output to the display device **40** the location of the corresponding template foci as a candidate for ablative therapy.

[0053] To compare a generated vector field map **70** to a vector field template **72**, the processing system **32** projects the vectors of the vector field map onto the vector field template and then determines a similarity index based on a similarity algorithm and/or a distance algorithm. The vector field templates **72** can be normalized according to, for example, a Frobenius norm to yield vector field templates which are represented in terms of units templates.

[0054] In some embodiments, the processing system **32** determines a reliability index for each vector of a generated vector field map **70** and selects vectors that meet a pre-selected reliability threshold for comparison with the template bank. In other words, the processing system **32** determines a subset of vectors from a vector field map **70** and the template matching with the vector field templates is performed with reliable vectors. The determined reliability of a vector can be influenced by the conductance of mapping electrode **24** which sensed the activation signal corresponding to the vector. For example, if 36 mapping electrodes of a total of 64 mapping electrodes have a reliable detection of activation signals based on the determined reliability index,

then the processing system 32 projects the 36 vectors associated with the 36 reliable mapping electrodes 24 onto each vector field template 72 for determining a similarity index. Since only a subset of vectors are used to determine the similarity index, the processing system 32 can determine the similarity index for each template 72 with increased efficiency due to a decrease in computation time and complexity because of the reduced number of projected vectors.

[0055] In some embodiments, the processing system 32 identifies a signature pattern and its corresponding location within a subset, sub-space, or region of each vector field map 70. Signature patterns and locations can be determined for a plurality of consecutive or subsequent vector field maps 72. The processing system 32 can identify signature patterns and locations in multiple distinct and/or overlapping subsets in parallel or sequentially. The signature patterns from the subsets can be employed to identify an overall global signature pattern for each entire vector field map 70. For example, the processing system 32 can generate a ranking of the signature patterns identified in all or preselected subsets corresponding to different regions of the anatomical structure. The global signature pattern can be identified according to the top ranked signature patterns identified in the distinct or overlapping subsets.

[0056] Once all vector fields are generated and a corresponding signature patterns and locations are identified, the processing system 32 can determine signature pattern locations which are candidates for therapy, such as ablative therapy, to reduce or eliminate a cardiac pathology such as fibrillation.

[0057] Various modifications and additions can be made to the exemplary embodiments discussed without departing from the scope of the present invention. For example, while the embodiments described above refer to particular features, the scope of this invention also includes embodiments having different combinations of features and embodiments that do not include all of the described features. Accordingly, the scope of the present invention is intended to embrace all such alternatives, modifications, and variations as fall within the scope of the claims, together with all equivalents thereof

We claim:

1. A method for mapping an anatomical structure, the method comprising:

sensing activation signals of intrinsic physiological activity with a plurality of mapping electrodes disposed in or near the anatomical structure, each of the plurality of mapping electrodes having an electrode location;

generating a vector field map which represents a direction of propagation of the activation signals at each electrode location;

identifying a signature pattern and a location in the vector field map according to at least one vector field template.

2. The method according to claim 1, wherein generating the vector field map further includes:

determining a vector of propagation at each electrode which represents a direction of propagation of the sensed activation signal with respect to at least one adjacent electrode.

3. The method according to claim 2, wherein generating the vector field map further includes:

determining a reliability index for each sensed activation signal at an electrode location according to at least one of a contact between the corresponding electrode and

the anatomical structure and a level of noise in the sensed activation signal; and

scaling each vector of the vector field map according to the corresponding reliability index.

4. The method according to claim 1, wherein identifying the signature pattern further includes:

receiving a template bank which includes a plurality of vector field templates, each vector field template having a unique signature pattern;

comparing the vector field map with each vector field template of the template bank; and

identifying the signature pattern that most closely matches the generated vector field map according to a similarity index.

5. The method according to claim 4, wherein each unique signature pattern of the template bank includes at least one of a divergent pattern representing focal activity having a foci location and a curled pattern representing rotor activity having a core location.

6. The method according to claim 4, wherein comparing the vector field further includes

determining a reliability index for each sensed activation signal at an electrode location according to at least one of a contact between the corresponding electrode and the anatomical structure and a level noise in the sensed activation signal;

selecting one or more vectors of the vector field map which meet a preselected threshold based on the determined reliability index; and

comparing only the one or more selected vectors with the corresponding vectors within each vector field template of the template bank.

7. The method according to claim 1, further including: displaying at least one of the generated vector field map and the identified target location.

8. A method for mapping cardiac tissue, the method comprising:

sensing activation signals of cardiac activity with a plurality of mapping electrodes disposed in or near the anatomical structure, each of the plurality of mapping electrodes having an electrode location;

generating a vector field map which represents a direction of propagation of the activation signals at each electrode location; and

identifying a signature pattern and a location in the vector field map according to at least one vector field template.

9. The method according to claim 8, wherein generating the vector field map further includes:

determining a vector at each electrode which represents a direction of propagation of the sensed activation signal with respect to at least one adjacent electrode.

10. The method according to claim 8, wherein generating the vector field map further includes:

determining a reliability index for each sensed activation signal at an electrode location based on at least one of a contact between the corresponding electrode and adjacent cardiac tissue and a level of noise in the sensed activation signal; and

scaling each vector of the vector field map according to the corresponding reliability index.

11. The method according to claim 8, wherein identifying the signature pattern further includes:

receiving a template bank which includes a plurality of vector field templates, each vector field template having a unique signature pattern;
 comparing the vector field map with each vector field template of the template bank; and
 identifying the signature pattern that most closely matches the generated vector field map according to a similarity index.

12. The method according to claim **11**, wherein each unique signature pattern of the template bank includes at least one of a divergent pattern representing focal activity having a foci location and a curled pattern representing rotor activity having a core location.

13. The method according to claim **11**, wherein comparing the vector field further includes:

determining a reliability index for each sensed activation signal at an electrode location according to a contact between the corresponding electrode and the anatomical structure;

selecting one or more vectors of the vector field map which meet a preselected threshold based on the determine reliability index; and

compare only the one or more selected vectors with the corresponding vectors within each vector field template of the template bank.

14. A catheter system comprising:

a plurality of mapping electrodes configured to detect activation signals of intrinsic cardiac activity, each of the plurality of mapping electrodes having an electrode location;

a mapping processor associated with the plurality of mapping electrodes, the mapping processor configured to record the detected activation signals and associate one of the plurality of mapping electrodes with each recorded activation signal, the mapping processor further configured to generate a vector field map which represents a direction of propagation of the activation signals at each electrode location, and identify a signature pattern and a location in the vector field map according to at least one vector field template.

15. The catheter system according to claim **14**, wherein to generate the vector field map the processing system is

further configured to determine a vector of propagation at each electrode which represents a direction of propagation of the sensed activation signal with respect to at least one adjacent electrode.

16. The catheter system according to claim **14**, wherein to generate the vector field map the processing system is further configured to determine a reliability index for each sensed activation signal at an electrode location according to at least one of a contact between the corresponding electrode and the anatomical structure and a level of noise in the sensed activation signal, and scale each vector of the vector field map according to the corresponding reliability index.

17. The catheter system according to claim **14**, wherein to identify the signature pattern the processing system is further configured to access a template bank which includes a plurality of vector field templates, each vector field template having a unique signature pattern, compare the vector field map with each vector field template of the template bank, and identify the signature pattern most closely matching the generated vector field map according to a similarity index.

18. The catheter system according to claim **17**, wherein each unique signature pattern of the template bank includes at least one of a divergent pattern representing focal activity having a foci location and a curled pattern representing rotor activity having a core location.

19. The catheter system according to claim **17**, wherein to compare the vector field the processing system is further configured to determine a reliability index for each sensed activation signal at an electrode location according to at least one of a contact between the corresponding electrode and the anatomical structure and a level of noise in the sensed activation signal, select one or more vectors of the vector field map which meet a preselected threshold based on the determine reliability index, and compare only the one or more selected vectors with the corresponding vectors within each vector field template of the template bank.

20. The catheter system according to claim **14**, further including:

a display device for displaying at least one of the generated vector field map and the identified target location.

* * * * *

专利名称(译)	使用矢量场在电生理学映射期间表示和识别活动模式		
公开(公告)号	US20180153426A1	公开(公告)日	2018-06-07
申请号	US15/890110	申请日	2018-02-06
[标]申请(专利权)人(译)	波士顿科学西美德公司		
申请(专利权)人(译)	BOSTON SCIENTIFIC SCIMED INC.		
当前申请(专利权)人(译)	BOSTON SCIENTIFIC SCIMED INC.		
[标]发明人	THAKUR PRAMODSINGH H SHOME SHIBAJI ARCOT KRISHNAMURTHY SHANTHA SHUROS ALLAN C MASKARA BARUN SAHA SUNIPA		
发明人	THAKUR, PRAMODSINGH H. SHOME, SHIBAJI ARCOT-KRISHNAMURTHY, SHANTHA SHUROS, ALLAN C. MASKARA, BARUN SAHA, SUNIPA		
IPC分类号	A61B5/04 A61B5/0402 A61B5/042 A61B5/044 A61B5/0452 A61B5/00 G06K9/00 A61B18/00 A61B18/14		
CPC分类号	A61B5/04012 G06K9/00496 A61B5/7221 A61B5/04023 A61B5/044 A61B5/0422 A61B5/04011 A61B2018/00577 A61B2018/00357 A61B18/1492 A61B5/04525 A61B5/7246 A61B5/7203 A61B5/6859 A61B5/6858 A61B5/6852		
优先权	61/823386 2013-05-14 US		
其他公开文献	US10555680		
外部链接	Espacenet USPTO		

摘要(译)

用于映射解剖结构的方法和系统包括利用设置在解剖结构中或附近的多个映射电极来感测固有生理活动的激活信号，所述多个映射电极中的每一个具有电极位置。产生表示每个电极位置处的激活信号的传播方向的矢量场图，以根据至少一个矢量场模板识别矢量场图中的签名图案和位置。根据相应的电极位置识别所识别的签名图案的目标位置。

