



US 20160166327A1

(19) **United States**
(12) **Patent Application Publication**
Keller

(10) **Pub. No.: US 2016/0166327 A1**
(43) **Pub. Date: Jun. 16, 2016**

(54) **BEDSIDE INTERFACE FOR PERCUTANEOUS CORONARY INTERVENTION PLANNING**

A61B 8/12 (2006.01)
G06F 19/00 (2011.01)

(71) Applicant: **VOLCANO CORPORATION**, San Diego, CA (US)

(52) **U.S. Cl.**
CPC *A61B 19/50* (2013.01); *A61B 5/0215* (2013.01); *A61B 5/7445* (2013.01); *A61B 5/743* (2013.01); *A61B 6/504* (2013.01); *A61B 6/032* (2013.01); *A61B 8/12* (2013.01); *A61B 8/0891* (2013.01); *A61B 5/0066* (2013.01); *A61F 2/82* (2013.01); *A61B 2019/507* (2013.01); *A61B 2019/501* (2013.01)

(72) Inventor: **Jacqueline Keller**, San Diego, CA (US)

(21) Appl. No.: **14/961,541**

(22) Filed: **Dec. 7, 2015**

Related U.S. Application Data

(60) Provisional application No. 62/089,051, filed on Dec. 8, 2014.

Publication Classification

(51) **Int. Cl.**
A61B 19/00 (2006.01)
A61B 5/00 (2006.01)
A61B 6/00 (2006.01)
A61B 6/03 (2006.01)
A61B 8/08 (2006.01)
A61F 2/82 (2006.01)
A61B 5/0215 (2006.01)

(57) **ABSTRACT**

Devices, systems, and methods configured to assess the severity of a blockage in a vessel and, in particular, a stenosis in a blood vessel, provide measurements of a vessel that allow assessment of the vessel and, in particular, any stenosis or lesion of the vessel, simulate diagnostic visualizations a first visualization device and a second visualization device. For example, the methods can include displaying, on a first visualization device, an image of the vessel with treatment diagnostic visualizations based on obtained pressure measurements and displaying, on a second visualization device, a portion of the image of the vessel with diagnostic visualizations based on the obtained pressure measurements, wherein the portion of the image of the vessel displayed on the second visualization device is a close up of a region of interest of the vessel.

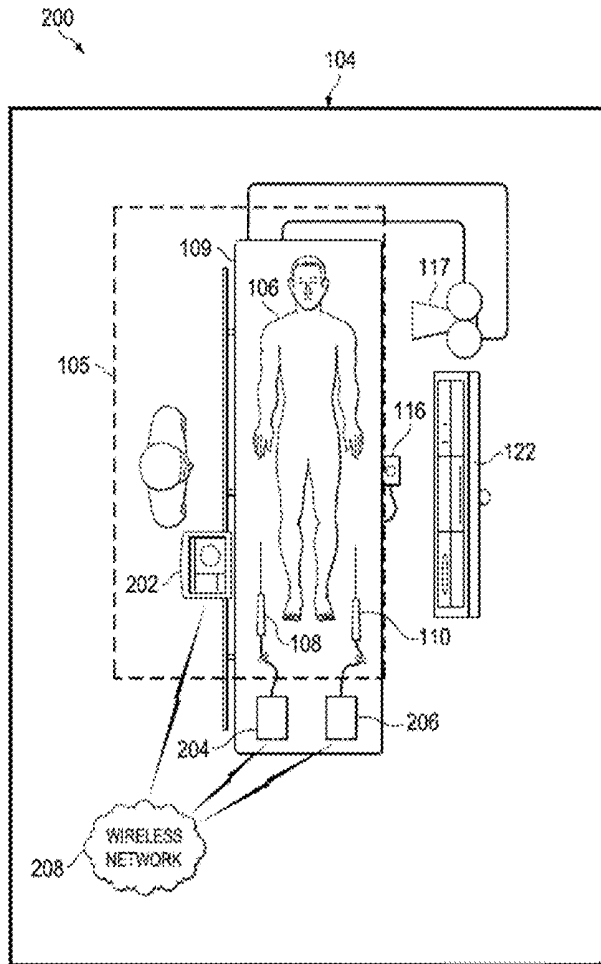

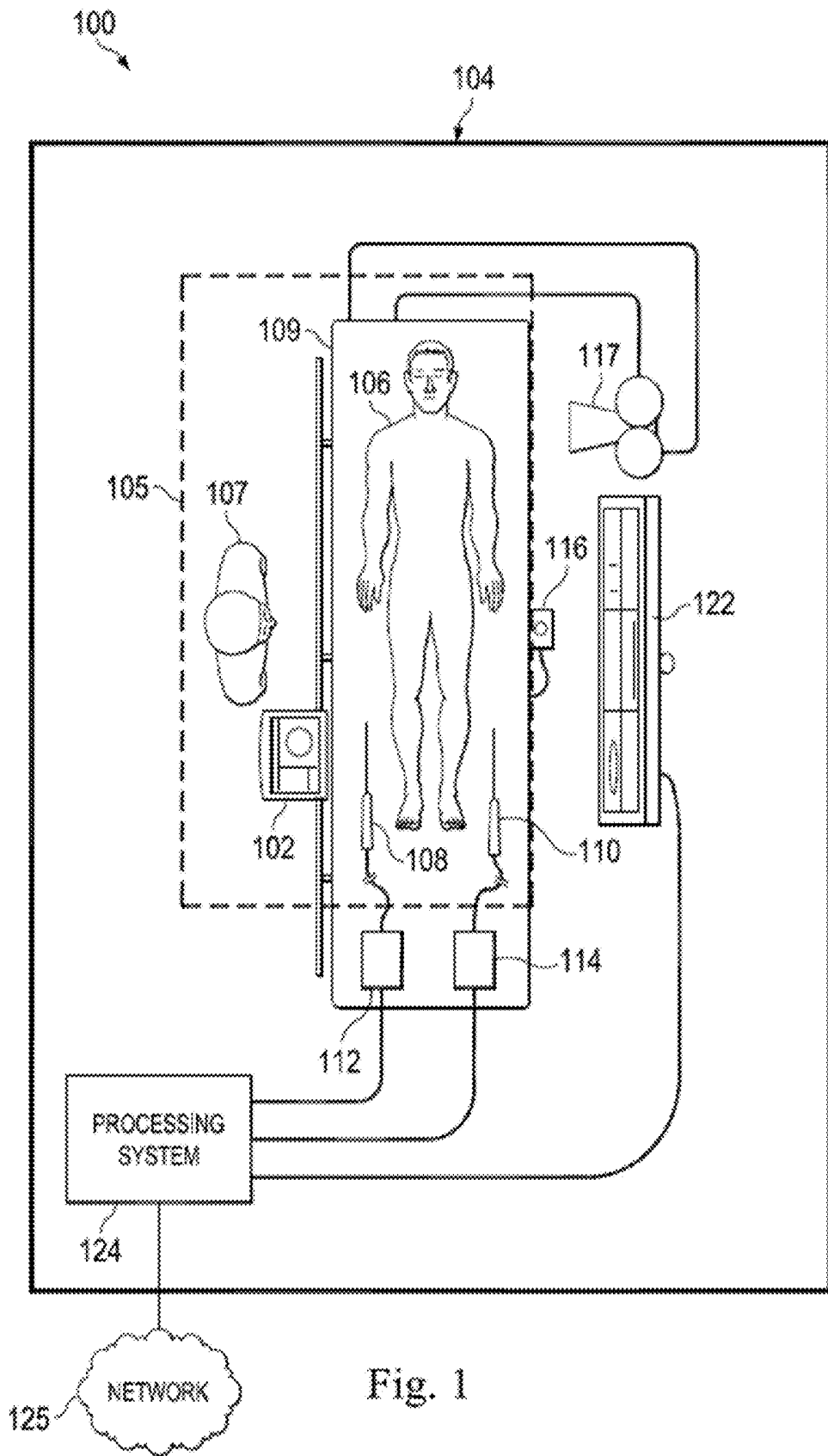

Fig. 1

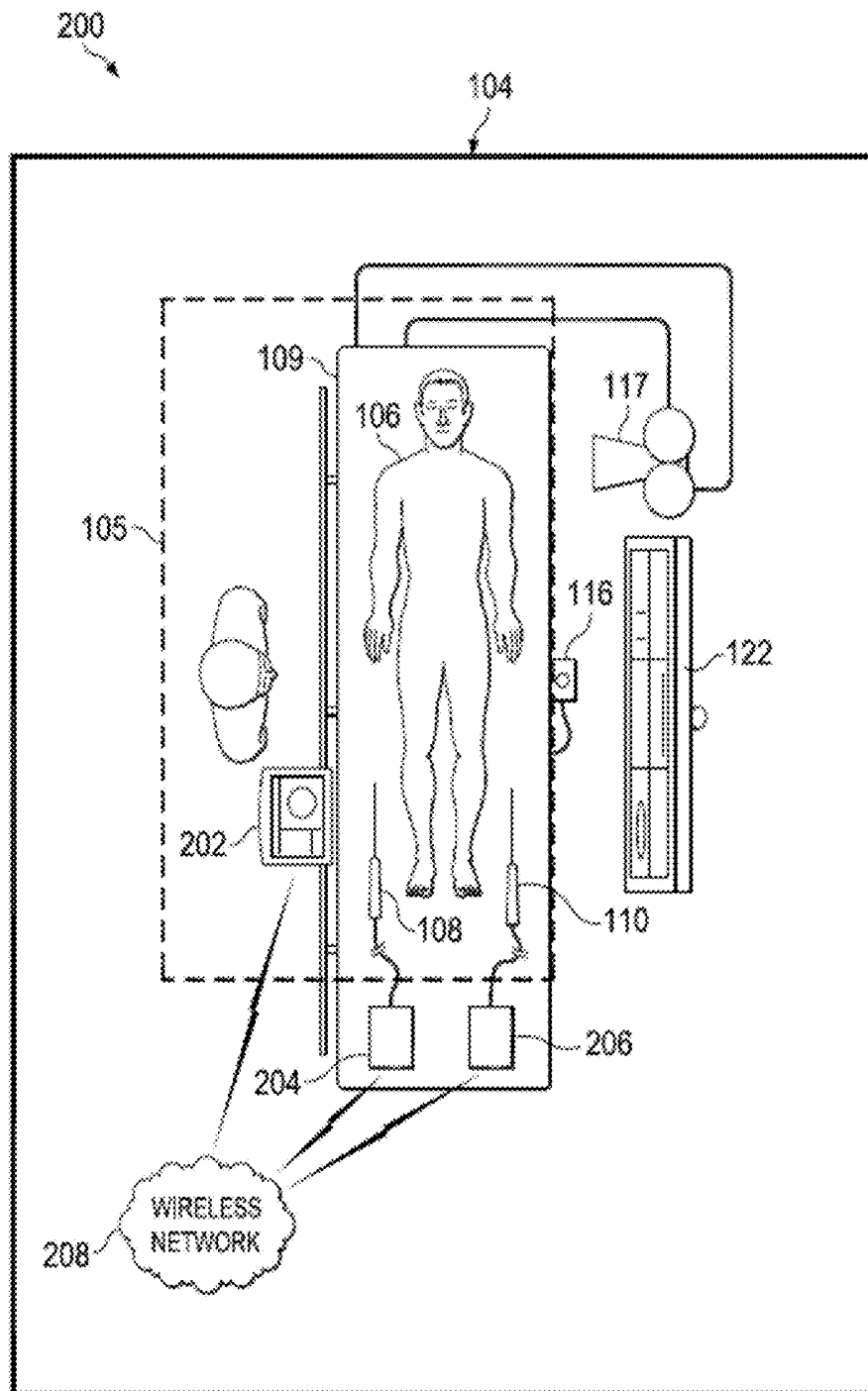

Fig. 2

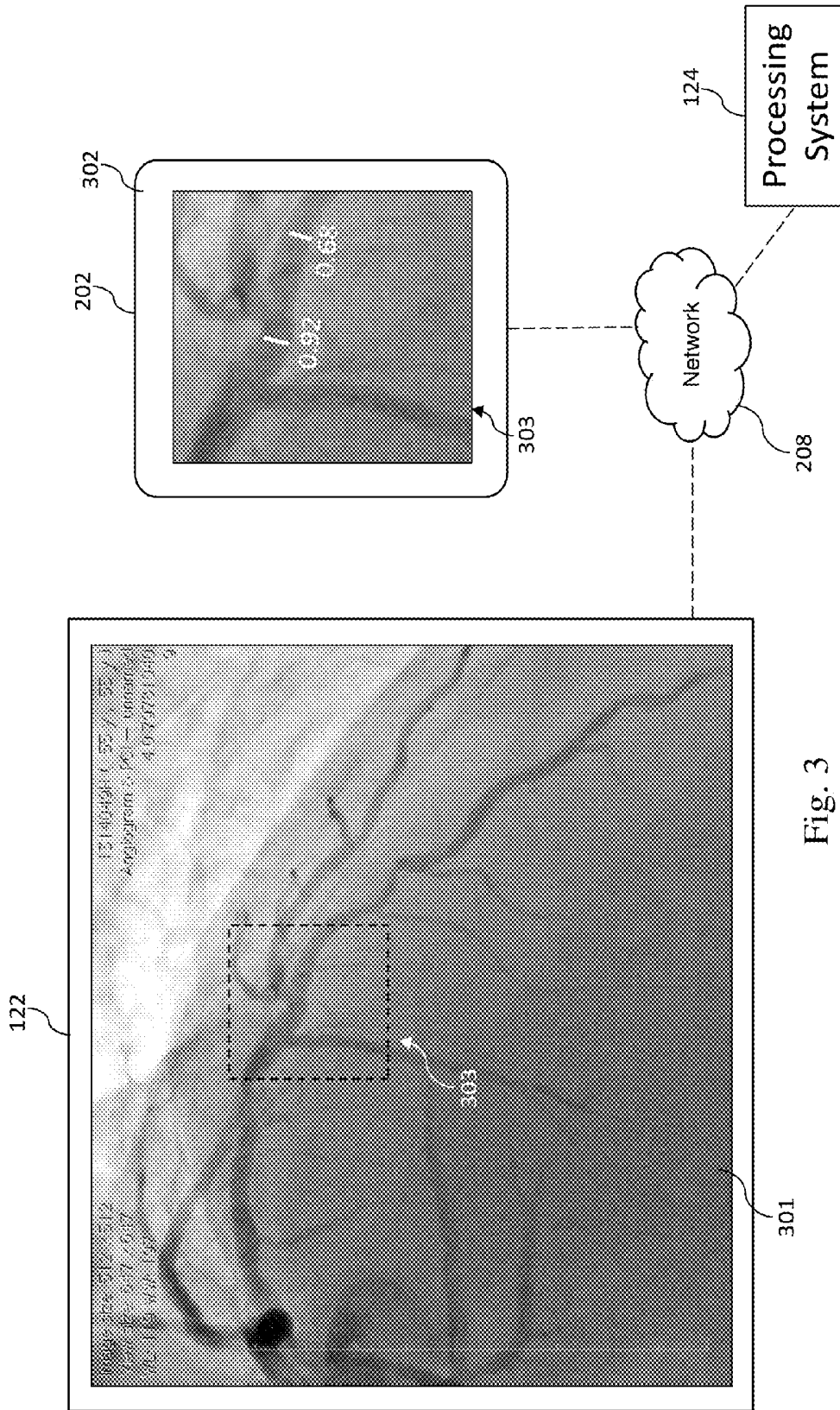

Fig. 3

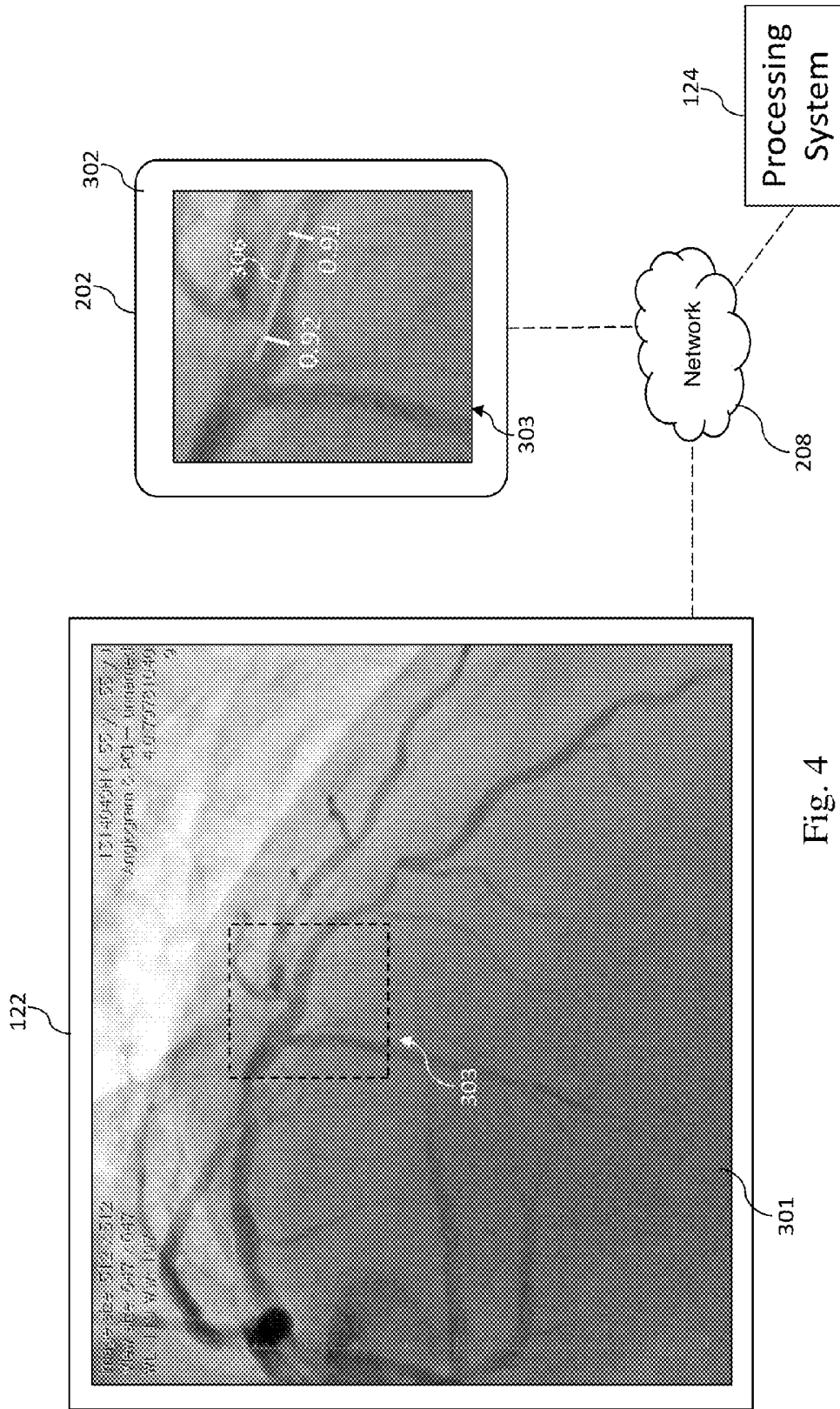

Fig. 4

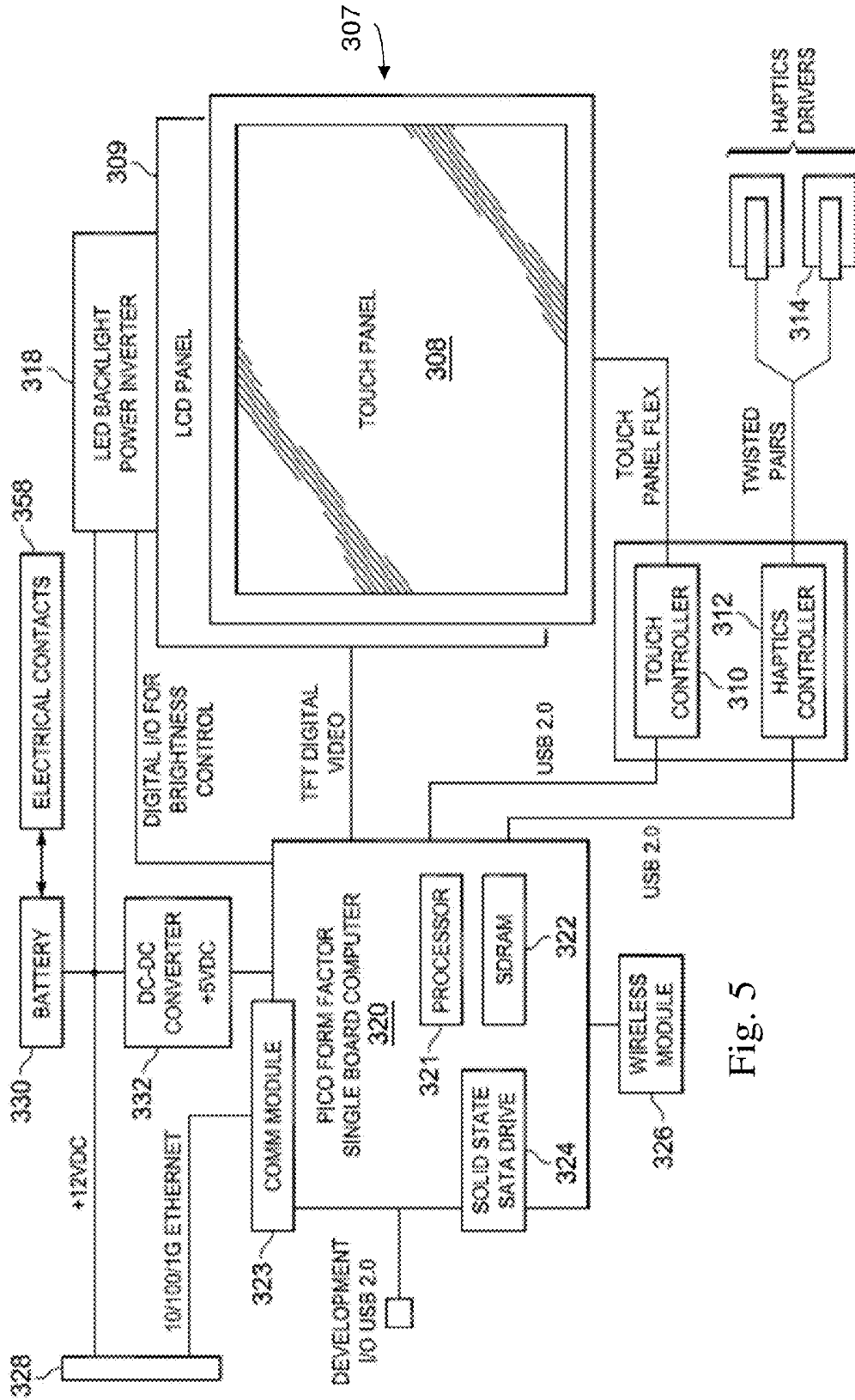

Fig. 5

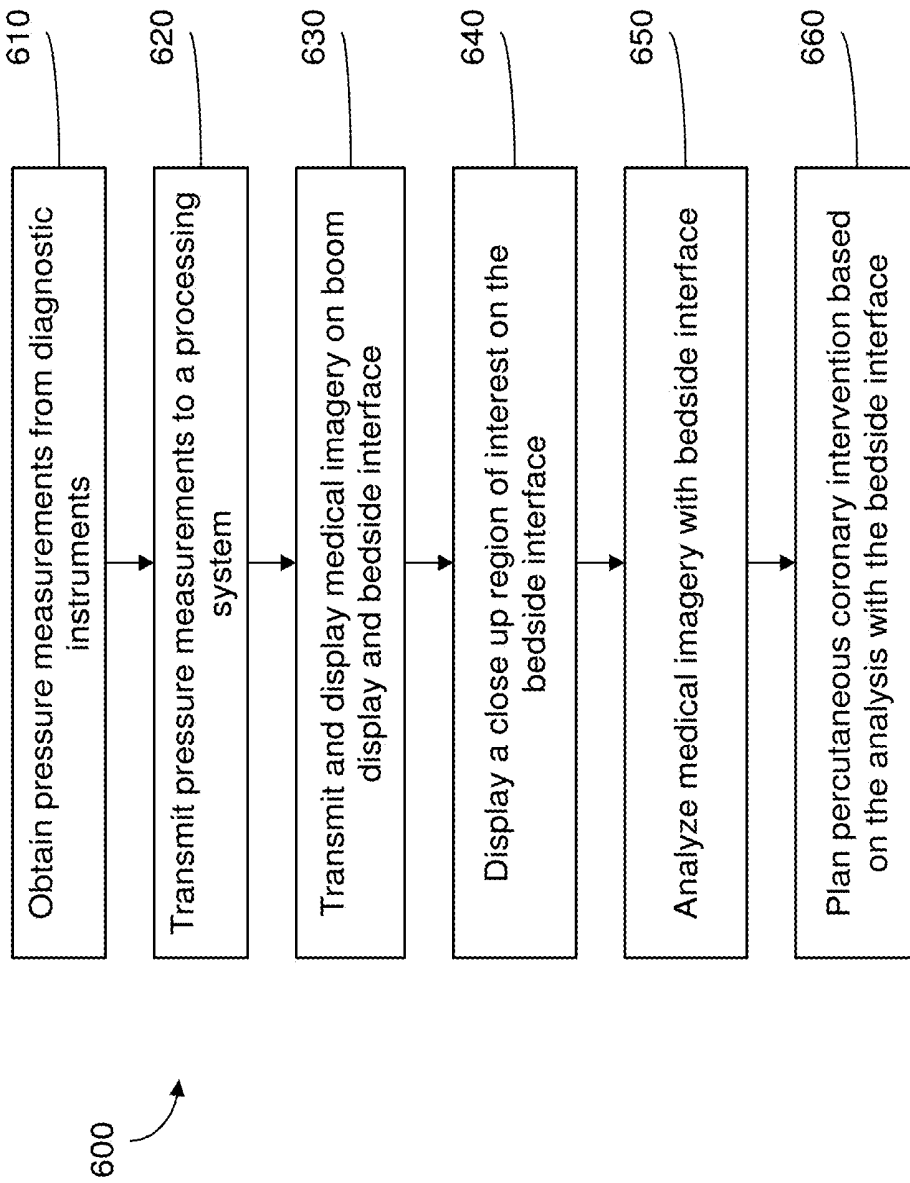

Fig. 6

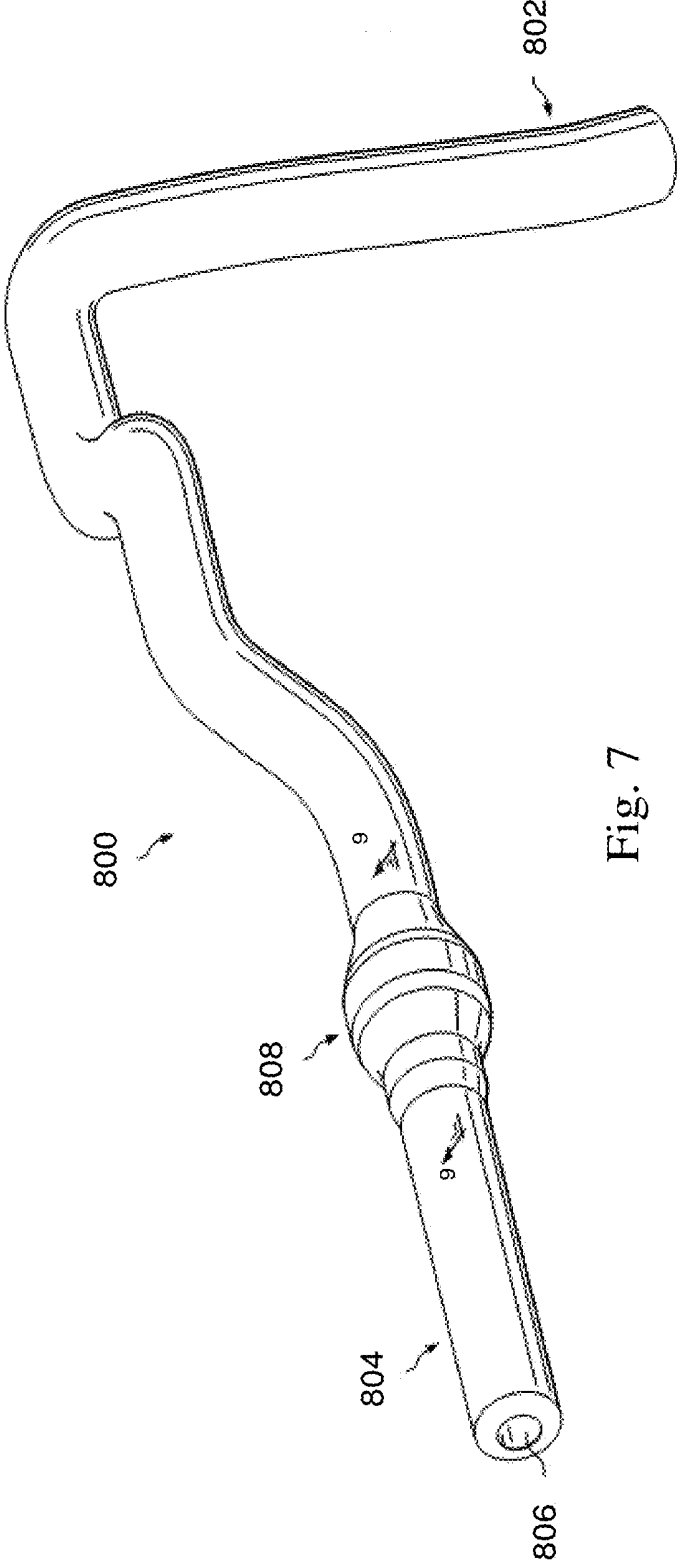

Fig. 7

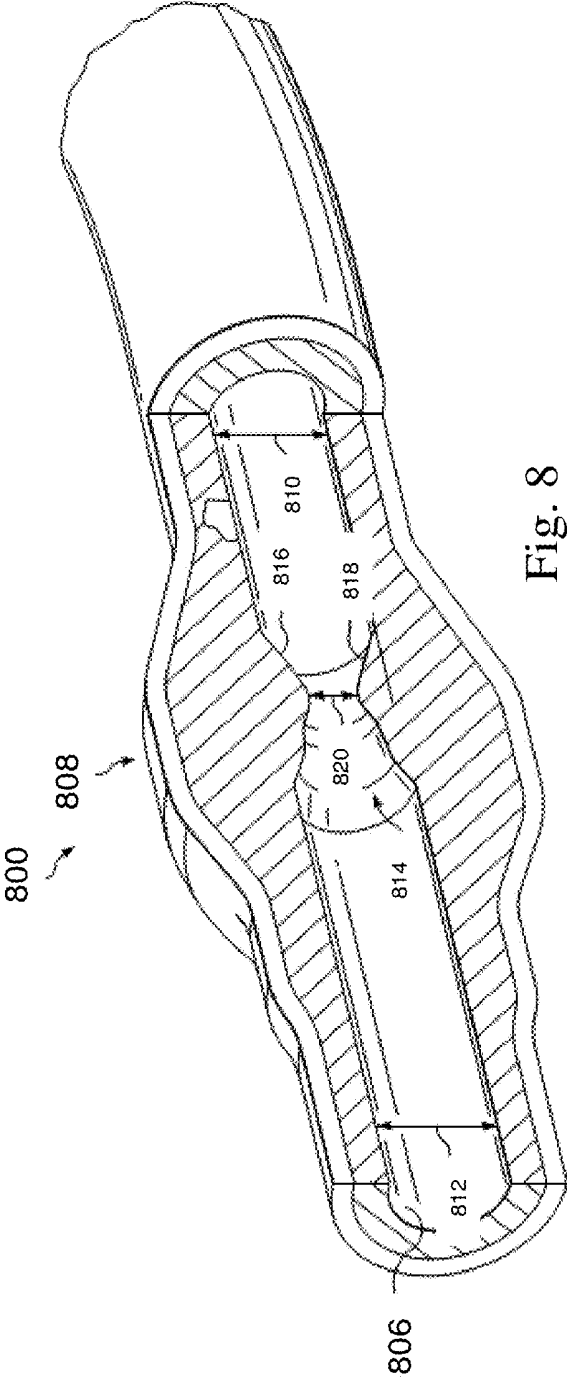

Fig. 8

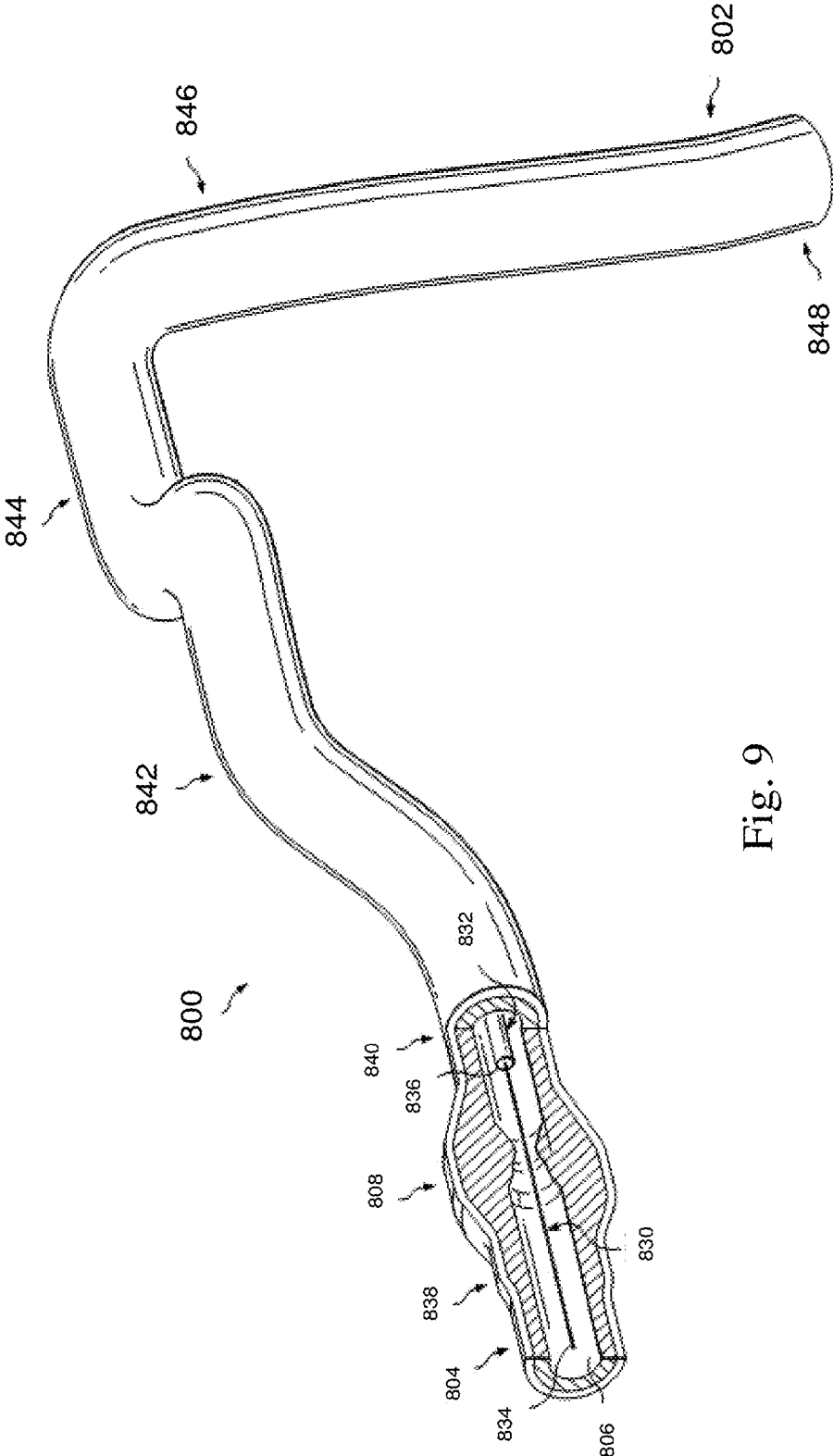

Fig. 9

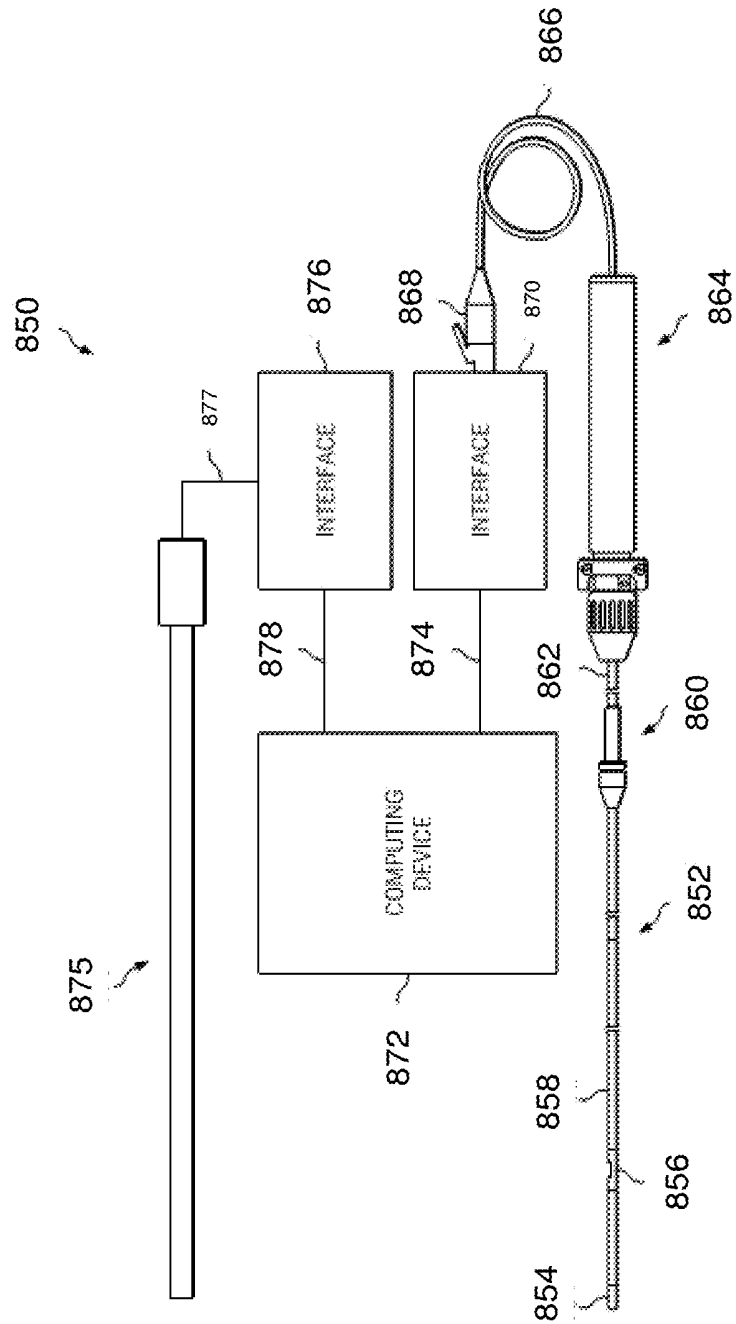

Fig. 10

BEDSIDE INTERFACE FOR PERCUTANEOUS CORONARY INTERVENTION PLANNING

CROSS REFERENCE TO RELATED APPLICATIONS

[0001] The present application claims priority to and the benefit of the U.S. Provisional Patent Application No. 62/089,051, filed Dec. 8, 2014, which is hereby incorporated by reference in its entirety.

TECHNICAL FIELD

[0002] The present disclosure relates generally to the assessment of vessels using a bedside interface. For example, some embodiments of the present disclosure are suited for assessing the severity of a blockage or other restriction to the flow of fluid through a vessel, such as a stenosis of a human blood vessel, by analyzing medical sensing data collected from the vessel using a touch-sensitive display of the bedside interface for use in percutaneous coronary intervention (PCI) planning.

BACKGROUND

[0003] Innovations in diagnosing and verifying the level of success of treatment of disease have progressed from solely external imaging processes to include internal diagnostic processes. In addition to traditional external image techniques such as X-ray, MRI, CT scans, fluoroscopy, and angiography, small sensors may now be placed directly in the body. For example, diagnostic equipment and processes have been developed for diagnosing vasculature blockages and other vasculature disease by means of ultra-miniature sensors placed upon the distal end of a flexible elongate member such as a catheter, or a guide wire used for catheterization procedures. For example, known medical sensing techniques include intravascular ultrasound (IVUS), forward looking IVUS (FL-IVUS), fractional flow reserve (FFR) determination, a coronary flow reserve (CFR) determination, optical coherence tomography (OCT), trans-esophageal echocardiography, and image-guided therapy. Traditionally, many of these procedures are carried out by a multitude of physicians and clinicians, where each performs an assigned task. For example, a physician may stand next to a patient in the sterile field and guide the insertion and pull back of a medical sensing catheter. A clinician near the physician may control the procedure workflow with an interface, for example by starting and stopping the acquisition of medical data. Further, once medical data has been acquired, a second clinician in an adjacent control room working at a desktop computer may analyze the data, such as by reviewing quantities calculated from the acquired data. If a display is available in the sterile field, it is static and a physician may need to look at several images in succession. Also, the physician in the catheter lab and the clinician in the control room must communicate in order to acquire and analyze the relevant medical data. This may lengthen the time of the procedure, increase the cost of the procedure, and may lead to errors due to miscommunication or clinician inexperience.

[0004] One exemplary type of procedure involves pressure measurements within a blood vessel. A currently accepted technique for assessing the severity of a stenosis in the blood vessel, including ischemia causing lesions, is fractional flow reserve (FFR). FFR is a calculation of the ratio of a distal pressure measurement (taken on the distal side of the steno-

sis) relative to a proximal pressure measurement (taken on the proximal side of the stenosis). FFR provides an index of stenosis severity that allows determination as to whether the blockage limits blood flow within the vessel to an extent that treatment is required. The normal value of FFR in a healthy vessel is 1.00, while values less than about 0.80 are generally deemed significant and require treatment. Common treatment options include angioplasty and stenting.

[0005] Coronary blood flow is unique in that it is affected not only by fluctuations in the pressure arising proximally (as in the aorta) but is also simultaneously affected by fluctuations arising distally in the microcirculation. Accordingly, it is not possible to accurately assess the severity of a coronary stenosis by simply measuring the fall in mean or peak pressure across the stenosis because the distal coronary pressure is not purely a residual of the pressure transmitted from the aortic end of the vessel. As a result, for an effective calculation of FFR within the coronary arteries, it is necessary to reduce the vascular resistance within the vessel. Currently, pharmacological hyperemic agents, such as adenosine, are administered to reduce and stabilize the resistance within the coronary arteries. These potent vasodilator agents reduce the dramatic fluctuation in resistance predominantly by reducing the microcirculation resistance associated with the systolic portion of the heart cycle to obtain a relatively stable and minimal resistance value.

[0006] However, the administration of hyperemic agents is not always possible or advisable. First, the clinical effort of administering hyperemic agents can be significant. In some countries (particularly the United States), hyperemic agents such as adenosine are expensive, and time consuming to obtain when delivered intravenously (IV). In that regard, IV-delivered adenosine is generally mixed on a case-by-case basis in the hospital pharmacy. It can take a significant amount of time and effort to get the adenosine prepared and delivered to the operating area. These logistic hurdles can impact a physician's decision to use FFR. Second, some patients have contraindications to the use of hyperemic agents such as asthma, severe COPD, hypotension, bradycardia, low cardiac ejection fraction, recent myocardial infarction, and/or other factors that prevent the administration of hyperemic agents. Third, many patients find the administration of hyperemic agents to be uncomfortable, which is only compounded by the fact that the hyperemic agent may need to be applied multiple times during the course of a procedure to obtain FFR measurements. Fourth, the administration of a hyperemic agent may also require central venous access (e.g., a central venous sheath) that might otherwise be avoided. Finally, not all patients respond as expected to hyperemic agents and, in some instances, it is difficult to identify these patients before administration of the hyperemic agent.

[0007] Accordingly, there remains a need for improved devices, systems, and methods for assessing the severity of a blockage in a vessel and, in particular, a stenosis in a blood vessel. There also remains a need for improved devices, systems, and methods for providing visual depictions of vessel that allow assessment of the vessel and, in particular, any stenosis or lesion of the vessel. Further, there remains a need for assessing the severity of a stenosis and for providing visual depictions of the vessel in an efficient and user friendly manner to facilitate PCI planning.

SUMMARY

[0008] Embodiments of the present disclosure are configured to assess the severity of a blockage in a vessel and, in particular, a stenosis in a blood vessel, provide visual depictions of vessel that allow assessment of the vessel and, in particular, any stenosis or lesion of the vessel, and simulate one or more treatment options for the vessel to facilitate planning and execution of percutaneous coronary interventions.

[0009] In some embodiments, methods of planning the treatment of a vessel of a patient are provided. These comprise obtaining pressure measurements from first and second instruments positioned within a vessel of a patient during a diagnostic procedure where the second instrument is moved longitudinally through the vessel from a first position to a second position and the first instrument remains stationary within the vessel; displaying on a first visualization device an image of the vessel with treatment diagnostic visualizations based on the obtained pressure measurements; and displaying on a second visualization device a portion of the image of the vessel with diagnostic visualizations based on the obtained pressure measurements, wherein the portion of the image of the vessel displayed on the second visualization device is a close up of a region of interest of the vessel.

[0010] In some embodiments, the first and second visualization devices are utilized to guide placement of one or more treatment devices associated with the identified treatment option. The second visualization device may also comprise a touch screen. The image displayed on the second visualization device may be at a higher magnification than the image displayed on the first visualization device. The second visualization device may be capable of higher magnification than the first visualization device.

[0011] In some instances, the image of the vessel comprises an extravascular image, and may be at least one of a two dimensional angiographic image, a three dimensional angiographic image, and a computed tomography angiographic (CTA) image. Alternatively, the image of the vessel comprises an intravascular image and may be at least one of an intravascular ultrasound (IVUS) image and an optical coherence tomography (OCT) image.

[0012] The diagnostic visualizations may include at least one of pressure measurements from the first instrument, pressure measurements from the second instrument, a ratio of the pressure measurements from the first and second instruments, an FFR value, or an iFR value. Additionally, the diagnostic visualizations may include an intensity map based on changes in a pressure ratio of the obtained pressure measurements from the first and second instruments, or a graph of a gradient of a pressure ratio of the obtained pressure measurements from the first and second instruments.

[0013] In one embodiment, a first treatment option is simulated, wherein simulating the first treatment option includes modifying the diagnostic visualizations based on an expected result of the first treatment option. Additionally, a second treatment option may be simulated, wherein simulating the second treatment option includes modifying the diagnostic visualizations based on an expected result of the second treatment option; and comparing the modified diagnostic visualizations associated with the first and second treatment options to identify a recommended treatment option. The first and second treatment options may be selected from the group

consisting of performing angioplasty, deploying one or more stents, applying a pharmaceutical agent, or combinations thereof.

[0014] A system of planning the treatment of a vessel of a patient is also provided, comprising: a first instrument sized and shaped for introduction into the vessel of the patient; a second instrument sized and shaped for introduction into the vessel of the patient; a processing system in communication with the first and second instruments, the processing unit configured to: obtain pressure measurements from first and second instruments positioned within a vessel of a patient during a diagnostic procedure where the second instrument is moved longitudinally through the vessel from a first position to a second position and the first instrument remains stationary within the vessel; display on a first visualization device an image of the vessel with treatment diagnostic visualizations based on the obtained pressure measurements; and display on a second visualization device a portion of the image of the vessel with diagnostic visualizations based on the obtained pressure measurements, wherein the portion of the image of the vessel displayed on the second visualization device is a close up of a region of interest of the vessel.

[0015] In some embodiments, the first and second visualization devices are utilized to guide placement of one or more treatment devices associated with the identified treatment option. The second visualization device may also comprise a touch screen. The image displayed on the second visualization device may be at a higher magnification than the image displayed on the first visualization device. The second visualization device may be capable of higher magnification than the first visualization device.

[0016] In some instances, the image of the vessel comprises an extravascular image, and may be at least one of a two dimensional angiographic image, a three dimensional angiographic image, and a computed tomography angiographic (CTA) image. Alternatively, the image of the vessel comprises an intravascular image and may be at least one of an intravascular ultrasound (IVUS) image and an optical coherence tomography (OCT) image.

[0017] The diagnostic visualizations may include at least one of pressure measurements from the first instrument, pressure measurements from the second instrument, a ratio of the pressure measurements from the first and second instruments, an FFR value, or an iFR value. Additionally, the diagnostic visualizations may include an intensity map based on changes in a pressure ratio of the obtained pressure measurements from the first and second instruments, or a graph of a gradient of a pressure ratio of the obtained pressure measurements from the first and second instruments.

[0018] In one embodiment, a first treatment option is simulated, wherein simulating the first treatment option includes modifying the diagnostic visualizations based on an expected result of the first treatment option. Additionally, a second treatment option may be simulated, wherein simulating the second treatment option includes modifying the diagnostic visualizations based on an expected result of the second treatment option; and comparing the modified diagnostic visualizations associated with the first and second treatment options to identify a recommended treatment option. The first and second treatment options may be selected from the group consisting of performing angioplasty, deploying one or more stents, applying a pharmaceutical agent, or combinations thereof.

[0019] Additional aspects, features, and advantages of the present disclosure will become apparent from the following detailed description.

BRIEF DESCRIPTION OF THE DRAWINGS

[0020] Illustrative embodiments of the present disclosure will be described with reference to the accompanying drawings, of which:

[0021] FIG. 1 is a schematic drawing depicting a medical sensing system including a bedside interface according to one embodiment of the present disclosure.

[0022] FIG. 2 is a schematic drawing depicting a medical sensing system including a wireless bedside interface according to another embodiment of the present disclosure.

[0023] FIG. 3 is a schematic drawing depicting medical imagery displays on the boom display and bedside interface according to one embodiment of the present disclosure.

[0024] FIG. 4 is a schematic drawing depicting medical imagery displays on the boom display and bedside interface according to one embodiment of the present disclosure.

[0025] FIG. 5 is a functional block diagram of the bedside interface of FIGS. 3A-3C according to aspects of the present disclosure.

[0026] FIG. 6 is a flowchart illustrating a method of conducting a medical sensing workflow with a bedside interface according to various aspects of the present disclosure.

[0027] FIG. 7 shows a diagrammatic perspective view of a vessel having a stenosis according to an embodiment of the present disclosure.

[0028] FIG. 8 shows a diagrammatic, partial cross-sectional perspective view of a portion of the vessel of FIG. 7 taken along section line 9-9 of FIG. 7.

[0029] FIG. 9 shows a diagrammatic, partial cross-sectional perspective view of the vessel of FIGS. 7 and 8 with instruments positioned therein according to an embodiment of the present disclosure.

[0030] FIG. 10 shows a diagrammatic, schematic view of a system according to an embodiment of the present disclosure.

DETAILED DESCRIPTION

[0031] For the purposes of promoting an understanding of the principles of the present disclosure, reference will now be made to the embodiments illustrated in the drawings, and specific language will be used to describe the same. It is nevertheless understood that no limitation to the scope of the disclosure is intended. Any alterations and further modifications to the described devices, systems, and methods, and any further application of the principles of the present disclosure are fully contemplated and included within the present disclosure as would normally occur to one skilled in the art to which the disclosure relates. In particular, it is fully contemplated that the features, components, and/or steps described with respect to one embodiment may be combined with the features, components, and/or steps described with respect to other embodiments of the present disclosure. For the sake of brevity, however, the numerous iterations of these combinations will not be described separately.

[0032] FIG. 1 is a schematic drawing depicting a medical sensing system 100 including a bedside interface 102 according to one embodiment of the present disclosure. In general, the medical sensing system 100 provides for coherent integration and consolidation of multiple forms of acquisition and processing elements designed to be sensitive to a variety

of methods used to acquire and interpret human biological physiology and morphological information. More specifically, in system 100, the bedside interface 102 is a touch-enabled, integrated computing device for the acquisition, control, interpretation, measurement, and display of medical sensing data. In the illustrated embodiment, the bedside interface 102 is a tablet-style touch-sensitive computer that provides user controls and diagnostic images on a single surface. In the medical sensing system 100, the bedside interface 102 is operable to diagnostic visualizations and patient image data via graphical user interfaces (GUIs) corresponding to a plurality of medical sensing modalities. Among these options is the ability of the bedside interface 102 to present magnified images of trouble spots and provide greater levels of detail to a user. The bedside interface 102 will be described in greater detail in association with FIGS. 3-6.

[0033] In the illustrated embodiment, the medical sensing system 100 is deployed in a catheter lab 104. The catheter lab 104 may be used to perform on a patient 106 any number of medical sensing procedures alone or in combination such as, by way of example and not limitation, angiography, intravascular ultrasound (IVUS), virtual histology (VH), forward looking IVUS (FL-IVUS), intravascular photoacoustic (IVPA) imaging, pressure, fractional flow reserve (FFR) determination, flow velocity, flow volume, coronary flow reserve (CFR) determination, optical coherence tomography (OCT), computed tomography, intracardiac echocardiography (ICE), forward-looking ICE (FLICE), intravascular palpography, transesophageal ultrasound, or any other medical sensing modalities known in the art. Catheter lab 104 can also conduct medical sensing procedures associated with Instant Wave-Free Ratio™ Functionality (iFR® Functionality) (both trademarks of Volcano Corp.) and those disclosed in U.S. patent application Ser. No. 13/460,296, entitled "DEVICES, SYSTEMS, AND METHODS FOR ASSESSING A VESSEL," hereby incorporated by reference in its entirety, which discloses the use of pressure ratios that are available without application of a hyperemic agent. Further, medical sensing procedures associated with compensated Pd/Pa ratios suitable for estimating iFR®, FFR, and/or other accepted diagnostic pressure ratios as disclosed in U.S. Provisional Patent Application No. 62/024,005, filed Jul. 14, 2014 and entitled "DEVICES, SYSTEMS, AND METHODS FOR TREATMENT OF VESSELS," which is hereby incorporated by reference in its entirety, can be conducted in the catheter lab 104. In addition to controlling medical sensing systems, the bedside interface may be used to cooperate with and control medical treatment systems such as, for example but without limitation, those used for stent placement, coil embolism, ablation therapy, kidney stone treatments, basket placement in a cystoscopy, tumor removal, and chemical therapies. The catheter lab 104 further includes a sterile field 105 that encompasses the portions of the catheter lab surrounding the patient 106 on a procedure table 109 and a clinician 107, who may perform any number of medical sensing procedures or treatments.

[0034] As shown in FIG. 1, the bedside interface 102 may be positioned within the sterile field 105 and may be utilized by the clinician 107 to control a workflow of a medical sensing procedure or treatment being performed on the patient 106. For example, the clinician 107 may initiate the procedure workflow, watch real-time medical sensing data, such as pressure measurements (e.g., visual representations of pressure data, such as pressure waveforms), obtained during the pro-

cedure, and interact with the obtained medical sensing data using the bedside interface **102** inside of the sterile field **105**. Additionally, the bedside interface may be used in conjunction with other imaging tools such as boom display **122**. The bedside interface **102** and boom display **122** may display the same imagery, or the bedside interface **102** may provide alternative imagery to assist medical professionals in diagnosing a patient or performing surgery. For example, the bedside interface **102** may show an alternative view angle or may overlay a highlighted image on that shown on the boom display **122**. In addition, the bedside interface **102** may be used to provide additional details on specific areas of interest. For example, the clinician **107** may view general diagnostic imagery on the boom display **122** and select a smaller portion of the imagery to display on the bedside interface **102**. The magnification of the display on the bedside interface **102** may be variable, allowing the clinician to zoom in on particular areas while still keeping the general imagery in view on the boom display **122**. The clinician **107** may zoom, rotate, and otherwise manipulate such images on the bedside interface **102** using simultaneous touch inputs (i.e. multitouch) and gestures. In alternative embodiments, the bedside interface **102** may be utilized outside of the sterile field **105**, for instance, in other locations within the catheter lab **104** or in a control room adjacent to the catheter lab **104**.

[0035] In the embodiment illustrated in FIG. 1, the medical sensing system **100** additionally includes a number of interconnected medical sensing-related tools in the catheter lab **104** to facilitate a pressure-sensing workflow procedure, such as a medical sensing device **108** and a medical sensing device **110**, and a processing system **124**. The medical sensing devices **108** and **110** can include pressure monitoring elements. Some embodiments of the medical sensing system **100** can include an patient interface module (PIM) **112** communicatively coupled to the medical sensing device **108**, PIM **114** communicatively coupled to the medical sensing device **110**, an electrocardiogram (ECG) device **116**, an angiogram system **117**, and a boom display **122**. The bedside interface **102**, PIMs **112** and **114**, ECG device **116**, angiography system **117**, and boom display **122** are communicatively coupled to the processing system **124**. In some embodiments, the medical sensing devices **108** and **110** can include imaging elements to facilitate an imaging workflow. In one embodiment, the processing system **124** is a computer workstation with the hardware and software to acquire, process, and display medical sensing data, but in other embodiments, the processing system may be any other type of computing system operable to process medical sensing data. For example, during a pressure-sensing workflow, the processing system **124** is operable to accept raw pressure data from the medical sensing devices **108** and **110** and/or the PIMs **112** and **114**, transform the pressure data into screen displays including, e.g., visual representations such as pressure waveforms, numerical values, computed values, etc., and make the screen display available to the bedside interface **124**, so that they may be displayed to the clinician **107** for analysis. In the embodiments in which the processing system **124** is a computer workstation, the system includes at least a processor such as a microinterface or a dedicated central processing unit (CPU), a non-transitory computer-readable storage medium such as a hard drive, random access memory (RAM), and/or compact disk read only memory (CD-ROM), a video interface such as a graphics processing unit (GPU), and a network communication device such as an Ethernet interface.

[0036] Further, the processing system **124** is communicatively coupled to a data network **125**. In the illustrated embodiment, the data network **125** is a TCP/IP-based local area network (LAN); however in other embodiments, it may utilize a different protocol such as Synchronous Optical Networking (SONET), or may be a wide area network (WAN). In that regard, the network **125** may utilize wired and/or wireless connections. In some instances, at least a portion of the network **125** is a cellular network. Other components of the system **100**, such as the bedside interface **102** and the boom display **122**, are connected to the processing system **124** either directly through a wired or wireless interface, or indirectly via network **125** or other networking components. Further, the processing system **124** may connect to various resources via the network **125**, such as a Digital Imaging and Communications in Medicine (DICOM) system, a Picture Archiving and Communication System (PACS), and a Hospital Information System. The processing system **124** can be similar to a multi-modality processing system that processes medical sensing data disclosed in U.S. Pat. No. 8,754,865, entitled "MEDICAL MEASURING SYSTEM AND METHOD" and issued on Jun. 17, 2014, and U.S. Patent Application No. 61/473,570, entitled "MULTI-MODALITY MEDICAL SENSING SYSTEM AND METHOD" and filed on Apr. 8, 2011, both of which are hereby incorporated by reference herein in their entireties.

[0037] In the medical sensing system **100**, the PIM **112** and PIM **114** are operable to respectively receive medical sensing data collected from the patient **106** by the medical sensing device **108** and medical sensing device **110** and are operable to transmit the received data to the processing system **124**. In one embodiment, the PIM **112** and PIM **114** transmit the medical sensing data over a Peripheral Component Interconnect Express (PCIe) data bus connection, but, in other embodiments, they may transmit data over a USB connection, a Thunderbolt connection, a FireWire connection, or some other high-speed data bus connection. Additionally, the ECG device **116** is operable to transmit electrocardiogram signals or other hemodynamic data from patient **106** to the processing system **124**. To aid the clinician in data capture, the bedside interface **102** is operable to display the ECG data alongside medical sensing data. Further, in some embodiments, the processing system **124** may be operable to synchronize data collection with the catheters **108** and **110** using ECG signals from the ECG **116**. Further, the angiogram system **117** is operable to collect x-ray, computed tomography (CT), or magnetic resonance images (MRI) of the patient **106** and transmit them to the processing system **124**. After the x-ray, CT, or MRI data has been processed into human-readable images by the processing system **124**, the clinician **107** may navigate the GUI on the bedside interface **124** to retrieve the images from the processing system **124** and display them on the interface. In some embodiments, the processing system **124** may co-register image data from angiogram system **117** (e.g. x-ray data, MRI data, CT data, etc.) with sensing data from the catheters **108** and **110**. As one aspect of this disclosure, the co-registration may be performed to generate three-dimensional images with the sensing data. Such co-registered 3-D images data may be viewable on the bedside interface **124**. In one embodiment, a clinician may rotate, zoom, and otherwise manipulate such 3-D images on the bedside interface **102** using simultaneous touch inputs (i.e. multitouch) and gestures.

[0038] Additionally, in the illustrated embodiment of FIG. 1, medical sensing tools in system 100 are communicatively coupled to the processing system 124 via a wired connection such as a standard copper link or a fiber optic link. Specifically, the bedside interface 124 may be communicatively and/or electrically coupled to the processing system 124 via a Universal Serial Bus (USB) connection, a Power-over-Ethernet connection, a Thunderbolt connection, a FireWire connection, or some other high-speed data bus connection.

[0039] However, in an alternative embodiment, such as that shown in FIG. 2, the medical sensing tools may communicate wirelessly. In that regard, FIG. 2 is a schematic drawing depicting a medical sensing system 200 including a wireless bedside interface 202 according to another embodiment of the present disclosure. The medical sensing system 200 is similar to the system 100 of FIG. 1 but the medical sensing tools including the wireless bedside interface 202, a wireless PIM 204, and a wireless PIM 206 communicate with a wireless network 208 via wireless networking protocols. For example, the bedside interface 202 may send and receive workflow control parameters, medical sensing images, and measurement data to and from a remote processing system via IEEE 802.11 Wi-Fi standards, Ultra Wide-Band (UWB) standards, wireless FireWire, wireless USB, Bluetooth, or another high-speed wireless networking standard. Such wireless capability allows the clinician 107 to more freely position the bedside interface 202 inside or outside of the sterile field 105 for better workflow management.

[0040] With reference now to FIG. 3, the bedside interface 202 includes an integrally formed housing 302 that is easy to grasp and move around a catheter lab or other medical setting. In one embodiment, the integrally formed housing 302 may be seamlessly molded from materials such as thermoplastic or thermosetting plastic or moldable metal. In other embodiments, the integrally formed housing 302 may comprise a plurality of housing portions fixedly bonded in a substantially permanent manner to form an integral housing. The housing 302 is resistant to fluids, and, in one embodiment, may have a rating of IPX4 against fluid ingress as defined by the International Electrotechnical Commission (IEC) standard 60529. In other embodiments in which the housing 302 may be used in different environments, the hub may have a different fluid ingress rating. In the illustrated embodiment, the housing 302 has a width, height, or thickness that is conducive to portability.

[0041] Still referring to the example of FIG. 3, the bedside interface 202 is configured to be used in conjunction with the boom display 122. In one embodiment, the bedside interface 202 and boom display 122 receive data obtained by intravascular sensors and/or imaging components and display corresponding medical imagery 301. Such imagery 301 can include static images, video, 3-D renderings, raw sensor or imaging data, filtered sensor or imaging data, calculated sensor or imaging data, and/or other data representative of the patient's anatomy. This data may be collected during a diagnostic procedure or may be collected during a surgical procedure, such as PCI. In one embodiment, diagnostic visualizations are overlaid on images of a vessel displayed on the boom display 122 and/or bedside interface 202. These diagnostic visualizations may assist the clinician 107 in determining the best available treatment options for a particular patient.

[0042] The diagnostic visualizations can include markings, colors, numerical values, or other representations of the data

obtained from medical instruments, such as guidewires and catheters. In that regard, the diagnostic visualizations can include intensity maps based on recorded pressure measurements and may incorporate graphs of corresponding pressure ratios. Further, the diagnostic visualizations may be overlaid onto extravascular images such as two-dimensional angiographic images, three-dimensional angiographic images, and computed tomography angiographic (CTA) images, and intravascular images such as ultrasound (IVUS) images and optical coherence tomography (OCT) images. In some instances, the diagnostic visualizations can include one type of image overlaid onto another type of image. Further, one or more treatment options can be simulated and the diagnostic visualizations updated based on the parameters associated with each particular simulated treatment option. In this manner, an estimated result or outcome for each treatment option can be visually provided to the clinician. The diagnostic visualizations and/or simulated treatments can be carried out as described in one or more of PCT Patent Application Publication No. WO 2013/028612, filed Aug. 20, 2012 and titled "DEVICES, SYSTEMS, AND METHODS FOR VISUALLY DEPICTING A VESSEL AND EVALUATING TREATMENT OPTIONS," U.S. Provisional Patent Application No. 61/895,909, filed Oct. 25, 2013 and titled "Devices, Systems, and Methods for Vessel Assessment," U.S. Provisional Patent Application No. 61/943,168, filed Feb. 21, 2014 and titled "DEVICES, SYSTEMS, AND METHODS AND ASSOCIATED DISPLAY SCREENS FOR ASSESSMENT OF VESSELS," U.S. Provisional Patent Application No. 62/024,005, filed Jul. 14, 2014 and titled "DEVICES, SYSTEMS, AND METHODS FOR TREATMENT OF VESSELS," each of which is hereby incorporated by reference in its entirety.

[0043] Based on the image(s), diagnostic visualization(s), and/or simulated treatments, a clinician can determine the best treatment option for the patient. Medical supervisors may also use the bedside interface 202 to check the work of clinicians 107 or to offer second opinions to a patient 106. Diagnostic visualizations may also be presented to a patient 106 or a caretaker of a patient 106 to assist a clinician 107 in explaining testing results or treatment options. Additionally, the bedside interface 202 may be used to guide the placement of treatment devices during a procedure. In this case, a clinician 107 may use the bedside interface 202 to check the location of medical instruments, guidewires, or stents to ensure positional accuracy during the procedure.

[0044] A portion 303 of the imagery 301 is displayed on the bedside interface 202 to allow a clinician 107 to view specific areas of interest in the imagery 301. The bedside interface 202 is equipped with a touch screen interface, allowing a clinician 107 to easily manipulate imagery 301 using simultaneous touch inputs and gestures. The bedside interface 202 is configured to be able to zoom into areas of interest and display images, graphical information, and text relating to the imagery 301. FIG. 3 shows that zoomed in portion 303 of the general imagery 301 that is displayed on the bedside interface 202. In the illustrated embodiment, a communication network 208 connects the boom display 122 and the bedside interface 202 to the processing system 124. A wireless connection to the bedside interface 202 may be favored during diagnostic procedures to allow a clinician 107 to carry, reposition, or move the bedside display 202 as desired. This allows for continual monitoring of certain key aspects of the procedure, and may allow a clinician 107 to communicate diagnos-

tic information and treatment options with a patient 106, another clinician 107, and/or a caretaker or family member of the patient.

[0045] As shown in FIG. 3, the bedside display 202 may also be used to display additional or more detailed diagnostic information for the portion 303 corresponding to the region of interest of the vessel. In this example, the boom display 122 displays imagery 301 of a patient while the bedside interface 202 shows the portion 303 of interest with diagnostic visualizations overlaid. In the example shown in FIG. 3, pressure ratios, such as FFR or iFR values, are shown along the region of interest of the vessel. As shown, there is a significant drop in the pressure ratio from 0.92 to 0.68 that can be indicative of a severe blockage or lesion. It is understood that any of a number of other types of diagnostic visualizations may be utilized as described above.

[0046] Further, one or more treatment options can be simulated and the diagnostic visualizations displayed on the bedside display 202 can be updated based on the parameters associated with a particular simulated treatment option. FIG. 4 shows an example of this approach. In particular, FIG. 4 shows the simulated deployment of a stent 306 and the corresponding resulting change in the diagnostic visualizations. In particular, the severe drop to 0.68 shown FIG. 3 is estimated to be improved significantly by deployment of the stent to a value of 0.91. Using this or similar approaches with other diagnostic visualization information, estimated results or outcomes for each treatment option can be visually provided to the clinician on the bedside display 202 and/or the overhead boom display 122. A simulated procedure may be displayed on the bedside interface 202 to show the likely outcome of a procedure. A simulated stent 306 is shown on the bedside interface 202 as well as statistical data 303 on the size and position of the stent. A clinician 107 may also place markers 305 on the imagery 301 of the bedside interface 202 to indicate important areas or provide ongoing pressure measurements. Simulations such as those shown in FIG. 4 may afford a clinician 107 a view of both the predicted result of a procedure on the bedside interface 202 and real-time imagery 301 of the patient on the boom display 122, affording a detailed and readily understandable analysis of treatment options. This analysis is also easily shared with a patient 106 or a patient's guardian or caretaker.

[0047] FIG. 5 shows a functional block diagram of the bedside controller 300 according to aspects of the present disclosure. Embedded into the front of the housing 302 is the touch-sensitive display 307 that comprises both a touch panel 308 and a flat panel display 309. The touch panel 308 overlays the flat panel display 308 and accepts user input via human touch, stylus touch, or some other analogous input method. In other words, the touch-sensitive display 307 displays images and accepts user input on the same surface. In the current embodiment, the touch panel 308 is a resistive-type panel, but in alternative embodiments it may be a capacitive-type panel, projective-type panel, or some other suitable type of touch enabled input panel. Further, the touch panel 308 is operable to accept multiple inputs simultaneously (multitouch), for instance, to enable rotation of a three-dimensional rendering of a vessel along multiple axes. Additionally, the touch panel 308 is capable of receiving input when a sterile drape 301 is covering the bedside interface 300 and also when a user is gloved. The touch panel 308 is controlled by a touch interface 310 disposed within the housing 302. Further, when a clinician makes contact with the touch panel 308, the touch panel

is operable to provide haptic feedback via a haptics interface 312 and haptics drivers 314. This haptic technology is operable to simulate a plurality of sensations on the touch panel 308 by varying the intensity and frequency of vibrations generated when a user contacts the touch panel. In some embodiments, the housing 302 may include a sheath configured to store a stylus therein. Thus, a clinician may remove the stylus from the sheath in the housing to make measurements on the bedside interface and store it when the measurements have been completed.

[0048] Beneath the touch panel 308 is the flat panel display 309 that presents a graphical user interface (GUI) 316 to a user. In the illustrated embodiment, the flat panel display 309 is a LCD display but in alternative embodiments, it may be a different type of display such as an LED display or an AMOLED display. In the illustrated embodiment, the flat panel display 309 is illuminated by a LED backlight power inverter 318. As mentioned above, the GUI 316 not only allows a clinician to control a medical sensing workflow, but also view and interact with pressure data obtained from a patient in the sterile field.

[0049] The bedside interface 300 includes a single board processing platform 320 within the housing 302 that is operable to render the GUI 316 and process user touch input. In the illustrated embodiment, the processing platform has a pico form factor and includes integrated processing components such as a processor 321, system memory 322, graphics processing unit (GPU), communications module 323, and I/O bus interface. In some embodiments, the processor 321 may be a low power processor such as an Intel Atom® processor or an ARM-based processor, and the communications module 323 may be a 10/100/1 Gb Ethernet module. And, the I/O bus interface may be a Universal Serial Bus (USB) interface. The bedside interface 300 further includes a storage module 324 that is a non-transitory computer readable storage medium operable to store an operating system (i.e. software to render and control the GUI), data and/or visual representation manipulation software, medical sensing data and visual representations received from a processing system, and other medical sensing-related software. The processor 321 is configured to execute software and instructions stored on the storage module 324. In the illustrated embodiment, the storage module 324 is a solid state drive (SSD) hard drive communicatively coupled to the processing platform 320 via a SATA connection, but, in alternative embodiments, it may be any other type of non-volatile or temporary storage module. The bedside interface 300 further includes a wireless communications module 326 communicatively coupled to the processing platform 320. In some embodiments, the wireless communications module is a IEEE 802.11 Wi-Fi module, but in other may be an Ultra Wide-Band (UWB) wireless module, a wireless FireWire module, a wireless USB module, a Bluetooth module, or another high-speed wireless networking module.

[0050] In the illustrated embodiment, the bedside interface 300 is powered via both a wired 12 VDC power-over-Ethernet (PoE) connection 328 and a battery 330 disposed within the housing 302. In one embodiment, the battery 330 may be sealed within the integrally formed housing 302 and may be recharged through electrical contacts disposed on the exterior of the housing and electrically coupled to the battery. As shown in the embodiment of FIG. 3B, the front wall 350 may include one or more electrical contacts 358 through which the battery 330 may be charged when the interface is mounted to

objects with compatible charging structure. In other embodiments, the housing **302** may include a battery compartment with a removable cover to permit battery replacement. Such a battery compartment cover may be resistant to fluid ingress (e.g., with an IPX4 rating). The bedside interface **300** may be coupled to a processing system in the catheter lab via the PoE connection **328**, over which it receives medical sensing images that have been captured from the patient and rendered on the processing system. In operation, when the bedside interface is coupled to the PoE connection **328**, it receives power and communications over the same physical wire. When the bedside interface **300** is disconnected from the PoE connection **328**, it runs on battery power and receives data wirelessly via the wireless communications module **326**. When used wirelessly in a catheter lab, the bedside interface may directly communicate with a processing system (i.e. in an ad-hoc wireless mode), or, alternatively, it may communicate with a wireless network that serves a plurality of wireless devices. In alternative embodiments, the bedside interface **300** may receive power and data through different wired connections, or receive data communications through a wired data connection and power from the battery **330**, or receive data communications through the wireless module **326** and power from a wired electrical connection. In some embodiments, the bedside interface **300** may be used in a semi-wireless configuration, in which the battery **330** provides backup power to the interface when the interface is temporarily disconnected from a wired power source. For example, if at the beginning of a procedure, the bedside interface **300** is connected to a PoE connection (or other type of wired connection) and during the procedure the interface must be disconnected from the PoE connection to allow for a cabling adjustment, the battery **330** may keep the interface alive until a PoE connection can be re-established. In this manner, a full power-off and reboot of the interface **300** is avoided during a procedure. As shown in FIG. 4, a DC-DC power converter **332** converts input voltage to a voltage usable by the processing platform **320**.

[0051] It is understood that although the bedside interface **300** includes specific components described herein, the bedside interface may include any number of additional components, for example a charge regulator interposed between the electrical contacts and the battery, and may be configured in any number of alternative arrangements in alternative embodiments.

[0052] FIG. 6 is a flowchart illustrating a method **600** of planning the treatment of a patient. The method **600** will be described in the context of a pressure-sensing procedure, such as an iFR procedure, but may equally apply to any number of medical sensing or treatment procedures, such as an FFR procedure, an IVUS procedure, OCT procedure, a FLIVUS procedure, an ICE procedure, etc. The method **600** can be better understood with reference to the FIGS. 7-10.

[0053] In that regard, referring to FIGS. 7 and 8, shown therein is a vessel **800** having a stenosis according to an embodiment of the present disclosure. In that regard, FIG. 7 is a diagrammatic perspective view of the vessel **800**, while FIG. 8 is a partial cross-sectional perspective view of a portion of the vessel **800**. Referring more specifically to FIG. 7, the vessel **800** includes a proximal portion **802** and a distal portion **804**. A lumen **806** extends along the length of the vessel **800** between the proximal portion **802** and the distal portion **804**. In that regard, the lumen **806** is configured to allow the flow of fluid through the vessel. In some instances,

the vessel **800** is a blood vessel. In some particular instances, the vessel **800** is a coronary artery. In such instances, the lumen **806** is configured to facilitate the flow of blood through the vessel **800**.

[0054] As shown, the vessel **800** includes a stenosis **808** between the proximal portion **802** and the distal portion **804**. Stenosis **808** is generally representative of any blockage or other structural arrangement that results in a restriction to the flow of fluid through the lumen **806** of the vessel **800**. Embodiments of the present disclosure are suitable for use in a wide variety of vascular applications, including without limitation coronary, peripheral (including but not limited to lower limb, carotid, and neurovascular), renal, and/or venous. Where the vessel **800** is a blood vessel, the stenosis **808** may be a result of plaque buildup, including without limitation plaque components such as fibrous, fibro-lipidic (fibro fatty), necrotic core, calcified (dense calcium), blood, fresh thrombus, and mature thrombus. Generally, the composition of the stenosis will depend on the type of vessel being evaluated. In that regard, it is understood that the concepts of the present disclosure are applicable to virtually any type of blockage or other narrowing of a vessel that results in decreased fluid flow.

[0055] Referring more particularly to FIG. 8, the lumen **806** of the vessel **800** has a diameter **810** proximal of the stenosis **808** and a diameter **812** distal of the stenosis. In some instances, the diameters **810** and **812** are substantially equal to one another. In that regard, the diameters **810** and **812** are intended to represent healthy portions, or at least healthier portions, of the lumen **806** in comparison to stenosis **808**. Accordingly, these healthier portions of the lumen **806** are illustrated as having a substantially constant cylindrical profile and, as a result, the height or width of the lumen has been referred to as a diameter. However, it is understood that in many instances these portions of the lumen **806** will also have plaque buildup, a non-symmetrical profile, and/or other irregularities, but to a lesser extent than stenosis **808** and, therefore, will not have a cylindrical profile. In such instances, the diameters **810** and **812** are understood to be representative of a relative size or cross-sectional area of the lumen and do not imply a circular cross-sectional profile.

[0056] As shown in FIG. 8, stenosis **808** includes plaque buildup **814** that narrows the lumen **806** of the vessel **800**. In some instances, the plaque buildup **814** does not have a uniform or symmetrical profile, making angiographic evaluation of such a stenosis unreliable. In the illustrated embodiment, the plaque buildup **814** includes an upper portion **816** and an opposing lower portion **818**. In that regard, the lower portion **818** has an increased thickness relative to the upper portion **816** that results in a non-symmetrical and non-uniform profile relative to the portions of the lumen proximal and distal of the stenosis **808**. As shown, the plaque buildup **814** decreases the available space for fluid to flow through the lumen **806**. In particular, the cross-sectional area of the lumen **806** is decreased by the plaque buildup **814**. At the narrowest point between the upper and lower portions **816**, **818** the lumen **806** has a height **820**, which is representative of a reduced size or cross-sectional area relative to the diameters **810** and **812** proximal and distal of the stenosis **808**. Note that the stenosis **808**, including plaque buildup **814** is exemplary in nature and should be considered limiting in any way. In that regard, it is understood that the stenosis **808** has other shapes and/or compositions that limit the flow of fluid through the lumen **806** in other instances. While the vessel **800** is illustrated in FIGS. 7 and 8 as having a single stenosis **808** and the descrip-

tion of the embodiments below is primarily made in the context of a single stenosis, it is nevertheless understood that the devices, systems, and methods described herein have similar application for a vessel having multiple stenosis regions.

[0057] Referring now to FIG. 9, the vessel 800 is shown with instruments 830 and 832 positioned therein according to an embodiment of the present disclosure. In general, instruments 830 and 832 may be any form of device, instrument, or probe sized and shaped to be positioned within a vessel. The instruments 830 and 832 can be implemented in the medical sensing system 100 (FIG. 1) as medical sensing devices 108 and 110. In the illustrated embodiment, instrument 830 is generally representative of a guide wire, while instrument 832 is generally representative of a catheter. In that regard, instrument 830 extends through a central lumen of instrument 832. However, in other embodiments, the instruments 830 and 832 take other forms. In that regard, the instruments 830 and 832 are of similar form in some embodiments. For example, in some instances, both instruments 830 and 832 are guide wires. In other instances, both instruments 830 and 832 are catheters. On the other hand, the instruments 830 and 832 are of different form in some embodiments, such as the illustrated embodiment, where one of the instruments is a catheter and the other is a guide wire. Further, in some instances, the instruments 830 and 832 are disposed coaxial with one another, as shown in the illustrated embodiment of FIG. 9. In other instances, one of the instruments extends through an off-center lumen of the other instrument. In yet other instances, the instruments 830 and 832 extend side-by-side. In some particular embodiments, at least one of the instruments is as a rapid-exchange device, such as a rapid-exchange catheter. In such embodiments, the other instrument is a buddy wire or other device configured to facilitate the introduction and removal of the rapid-exchange device. Further still, in other instances, instead of two separate instruments 830 and 832 a single instrument is utilized. In some embodiments, the single instrument incorporates aspects of the functionalities (e.g., data acquisition) of both instruments 830 and 832.

[0058] Instrument 830 is configured to obtain diagnostic information about the vessel 800. In that regard, the instrument 830 includes one or more sensors, transducers, and/or other monitoring elements configured to obtain the diagnostic information about the vessel. The diagnostic information includes one or more of pressure, flow (velocity and/or volume), images (including images obtained using ultrasound (e.g., IVUS), OCT, thermal, and/or other imaging techniques), temperature, and/or combinations thereof. The one or more sensors, transducers, and/or other monitoring elements are positioned adjacent a distal portion of the instrument 830 in some instances. In that regard, the one or more sensors, transducers, and/or other monitoring elements are positioned less than 30 cm, less than 10 cm, less than 5 cm, less than 3 cm, less than 2 cm, and/or less than 1 cm from a distal tip 834 of the instrument 830 in some instances. In some instances, at least one of the one or more sensors, transducers, and/or other monitoring elements is positioned at the distal tip of the instrument 830.

[0059] The instrument 830 includes at least one element configured to monitor pressure within the vessel 800. The pressure monitoring element can take the form a piezo-resistive pressure sensor, a piezo-electric pressure sensor, a capacitive pressure sensor, an electromagnetic pressure sen-

sor, a fluid column (the fluid column being in communication with a fluid column sensor that is separate from the instrument and/or positioned at a portion of the instrument proximal of the fluid column), an optical pressure sensor, and/or combinations thereof. In some instances, one or more features of the pressure monitoring element are implemented as a solid-state component manufactured using semiconductor and/or other suitable manufacturing techniques. Examples of commercially available guide wire products that include suitable pressure monitoring elements include, without limitation, the PrimeWire PRESTIGE® pressure guide wire, the PrimeWire® pressure guide wire, and the ComboWire® XT pressure and flow guide wire, each available from Volcano Corporation, as well as the PressureWire™ Certus guide wire and the PressureWire™ Aeris guide wire, each available from St. Jude Medical, Inc. Generally, the instrument 830 is sized such that it can be positioned through the stenosis 808 without significantly impacting fluid flow across the stenosis, which would impact the distal pressure reading. Accordingly, in some instances the instrument 830 has an outer diameter of 0.018" or less. In some embodiments, the instrument 830 has an outer diameter of 0.014" or less.

[0060] Instrument 832 is also configured to obtain diagnostic information about the vessel 100. In some instances, instrument 832 is configured to obtain the same diagnostic information as instrument 830. In other instances, instrument 832 is configured to obtain different diagnostic information than instrument 830, which may include additional diagnostic information, less diagnostic information, and/or alternative diagnostic information. The diagnostic information obtained by instrument 832 includes one or more of pressure, flow (velocity and/or volume), images (including images obtained using ultrasound (e.g., IVUS), OCT, thermal, and/or other imaging techniques), temperature, and/or combinations thereof. Instrument 832 includes one or more sensors, transducers, and/or other monitoring elements configured to obtain this diagnostic information. In that regard, the one or more sensors, transducers, and/or other monitoring elements are positioned adjacent a distal portion of the instrument 832 in some instances. In that regard, the one or more sensors, transducers, and/or other monitoring elements are positioned less than 30 cm, less than 10 cm, less than 5 cm, less than 3 cm, less than 2 cm, and/or less than 1 cm from a distal tip 836 of the instrument 832 in some instances. In some instances, at least one of the one or more sensors, transducers, and/or other monitoring elements is positioned at the distal tip of the instrument 832.

[0061] Similar to instrument 830, instrument 832 also includes at least one element configured to monitor pressure within the vessel 800. The pressure monitoring element can take the form a piezo-resistive pressure sensor, a piezo-electric pressure sensor, a capacitive pressure sensor, an electromagnetic pressure sensor, a fluid column (the fluid column being in communication with a fluid column sensor that is separate from the instrument and/or positioned at a portion of the instrument proximal of the fluid column), an optical pressure sensor, and/or combinations thereof. In some instances, one or more features of the pressure monitoring element are implemented as a solid-state component manufactured using semiconductor and/or other suitable manufacturing techniques. Currently available catheter products suitable for use with one or more of Siemens AXIOM Sensis, Mennen Horizon XVu, and Philips Xper IM Physiomonitoring 5 and

include pressure monitoring elements can be utilized for instrument **832** in some instances.

[0062] In accordance with aspects of the present disclosure, at least one of the instruments **830** and **832** is configured to monitor a pressure within the vessel **800** distal of the stenosis **808** and at least one of the instruments **830** and **832** is configured to monitor a pressure within the vessel proximal of the stenosis. In that regard, the instruments **830**, **832** are sized and shaped to allow positioning of the at least one element configured to monitor pressure within the vessel **800** to be positioned proximal and/or distal of the stenosis **808** as necessary based on the configuration of the devices. In that regard, FIG. 9 illustrates a position **838** suitable for measuring pressure distal of the stenosis **808**. In that regard, the position **838** is less than 5 cm, less than 3 cm, less than 2 cm, less than 1 cm, less than 5 mm, and/or less than 2.5 mm from the distal end of the stenosis **808** (as shown in FIG. 8) in some instances. FIG. 9 also illustrates a plurality of suitable positions for measuring pressure proximal of the stenosis **808**. In that regard, positions **840**, **842**, **844**, **846**, and **848** each represent a position that is suitable for monitoring the pressure proximal of the stenosis in some instances. In that regard, the positions **840**, **842**, **844**, **846**, and **848** are positioned at varying distances from the proximal end of the stenosis **808** ranging from more than 20 cm down to about 5 mm or less. Generally, the proximal pressure measurement will be spaced from the proximal end of the stenosis. Accordingly, in some instances, the proximal pressure measurement is taken at a distance equal to or greater than an inner diameter of the lumen of the vessel from the proximal end of the stenosis. In the context of coronary artery pressure measurements, the proximal pressure measurement is generally taken at a position proximal of the stenosis and distal of the aorta, within a proximal portion of the vessel. However, in some particular instances of coronary artery pressure measurements, the proximal pressure measurement is taken from a location inside the aorta. In other instances, the proximal pressure measurement is taken at the root or ostium of the coronary artery.

[0063] In some embodiments, at least one of the instruments **830** and **832** is configured to monitor pressure within the vessel **800** while being moved through the lumen **806**. In some instances, instrument **830** is configured to be moved through the lumen **806** and across the stenosis **808**. In that regard, the instrument **830** is positioned distal of the stenosis **808** and moved proximally (i.e., pulled back) across the stenosis to a position proximal of the stenosis in some instances. In other instances, the instrument **830** is positioned proximal of the stenosis **808** and moved distally across the stenosis to a position distal of the stenosis. Movement of the instrument **830**, either proximally or distally, is controlled manually by medical personnel (e.g., hand of a surgeon) in some embodiments. In other embodiments, movement of the instrument **830**, either proximally or distally, is controlled automatically by a movement control device (e.g., a pullback device, such as the Trak Back® II Device available from Volcano Corporation). In that regard, the movement control device controls the movement of the instrument **830** at a selectable and known speed (e.g., 2.0 mm/s, 1.0 mm/s, 0.5 mm/s, 0.2 mm/s, etc.) in some instances. Movement of the instrument **830** through the vessel is continuous for each pullback or push through, in some instances. In other instances, the instrument **830** is moved step-wise through the vessel (i.e., repeatedly moved a fixed amount of distance and/or a fixed amount of time). Some aspects of the visual

depictions discussed below are particularly suited for embodiments where at least one of the instruments **830** and **832** is moved through the lumen **806**. Further, in some particular instances, aspects of the visual depictions discussed below are particularly suited for embodiments where a single instrument is moved through the lumen **806**, with or without the presence of a second instrument.

[0064] In some instances, use of a single instrument has a benefit in that it avoids issues associated with variations in pressure measurements of one instrument relative to another over time, which is commonly referred to as drift. In that regard, a major source of drift in traditional Fractional Flow Reserve (FFR) measurements is divergence in the pressure reading of a guide wire relative to the pressure reading of a guide catheter. In that regard, because FFR is calculated as the ratio of the pressure measurement obtained by the guide wire to the pressure measurement obtained by the catheter, this divergence has an impact on the resulting FFR value. In contrast, where a single instrument is utilized to obtain pressure measurements as it is moved through the vessel, drift is negligible or non-existent. For example, in some instances, the single instrument is utilized to obtain relative changes in pressures as it is moved through the vessel such that the time period between pressure measurements is short enough to prevent any impact from any changes in pressure sensitivity of the instrument (e.g., less than 500 ms, less than 100 ms, less than 50 ms, less than 10 ms, less than 5 ms, less than 1 ms, or otherwise).

[0065] Referring now to FIG. 10, shown therein is a system **850** according to an embodiment of the present disclosure. In that regard, FIG. 10 is a diagrammatic, schematic view of the system **850**. In some embodiments, the system **850** can be implemented as the medical sensing system **100** (FIG. 1). In some embodiments, one or more components of the medical sensing system **100** can be additionally implemented in the system **850**, such as a bedside interface having a touch-sensitive display. As shown, the system **850** includes an instrument **852**. In that regard, in some instances instrument **852** is suitable for use as at least one of instruments **830** and **832** (FIGS. 8-10) and/or medical sensing devices **108** and **110** (FIG. 1), discussed above. Accordingly, in some instances the instrument **852** includes features similar to those discussed above with respect to instruments **830** and **832** in some instances. In the illustrated embodiment, the instrument **852** is a guide wire having a distal portion **854** and a housing **856** positioned adjacent the distal portion. In that regard, the housing **856** is spaced approximately 3 cm from a distal tip of the instrument **852**. The housing **856** is configured to house one or more sensors, transducers, and/or other monitoring elements configured to obtain the diagnostic information about the vessel. In the illustrated embodiment, the housing **856** contains at least a pressure sensor configured to monitor a pressure within a lumen in which the instrument **852** is positioned. A shaft **858** extends proximally from the housing **856**. A torque device **860** is positioned over and coupled to a proximal portion of the shaft **858**. A proximal end portion **862** of the instrument **852** is coupled to a connector **864**. A cable **866** extends from connector **864** to a connector **868**. In some instances, connector **868** is configured to be plugged into an interface **870**. In that regard, interface **870** is a patient interface module (PIM) in some instances. The interface **870** can be implemented as the PIM **112** (FIG. 1). In some instances, the cable **866** is replaced with a wireless connection. In that regard, it is understood that various communication pathways

between the instrument **852** and the interface **870** may be utilized, including physical connections (including electrical, optical, and/or fluid connections), wireless connections, and/or combinations thereof.

[0066] The interface **870** is communicatively coupled to a computing device **872** via a connection **874**. Computing device **872** is generally representative of any device suitable for performing the processing and analysis techniques discussed within the present disclosure. In some embodiments, the computing device **872** includes a processor, random access memory, and a storage medium. In that regard, in some particular instances the computing device **872** is programmed to execute steps associated with the data acquisition and analysis described herein. Accordingly, it is understood that any steps related to data acquisition, data processing, instrument control, and/or other processing or control aspects of the present disclosure may be implemented by the computing device using corresponding instructions stored on or in a non-transitory computer readable medium accessible by the computing device. In some instances, the computing device **872** is the bedside interface. For example, the processing steps described herein can be performed by one or more processing components of the bedside interface, such as the processing platform **320**. In some instances, the computing device **872** is a console device. In some particular instances, the computing device **872** is similar to the s5TM Imaging System or the s5iTM Imaging System, each available from Volcano Corporation. In some instances, the computing device **872** is portable (e.g., handheld, on a rolling cart, etc.). Further, it is understood that in some instances the computing device **872** comprises a plurality of computing devices. In that regard, it is particularly understood that the different processing and/or control aspects of the present disclosure may be implemented separately or within predefined groupings using a plurality of computing devices. Any divisions and/or combinations of the processing and/or control aspects described below across multiple computing devices are within the scope of the present disclosure.

[0067] Together, connector **864**, cable **866**, connector **868**, interface **870**, and connection **874** facilitate communication between the one or more sensors, transducers, and/or other monitoring elements of the instrument **852** and the computing device **872**. However, this communication pathway is exemplary in nature and should not be considered limiting in any way. In that regard, it is understood that any communication pathway between the instrument **852** and the computing device **872** may be utilized, including physical connections (including electrical, optical, and/or fluid connections), wireless connections, and/or combinations thereof. In that regard, it is understood that the connection **874** is wireless in some instances. In some instances, the connection **874** includes a communication link over a network (e.g., intranet, internet, telecommunications network, and/or other network). In that regard, it is understood that the computing device **872** is positioned remote from an operating area where the instrument **152** is being used in some instances. Having the connection **874** include a connection over a network can facilitate communication between the instrument **852** and the remote computing device **872** regardless of whether the computing device is in an adjacent room, an adjacent building, or in a different state/country. Further, it is understood that the communication pathway between the instrument **852** and the computing device **872** is a secure connection in some instances. Further still, it is understood that, in some

instances, the data communicated over one or more portions of the communication pathway between the instrument **852** and the computing device **872** is encrypted.

[0068] The system **850** also includes an instrument **875**. In that regard, in some instances instrument **875** is suitable for use as at least one of instruments **130** and **132** (FIGS. 7-9) and/or medical sensing devices **108** and **110** (FIG. 1), discussed above. Accordingly, in some instances the instrument **875** includes features similar to those discussed above with respect to instruments **130** and **132** in some instances. In the illustrated embodiment, the instrument **875** is a catheter-type device. In that regard, the instrument **875** includes one or more sensors, transducers, and/or other monitoring elements adjacent a distal portion of the instrument configured to obtain the diagnostic information about the vessel. In the illustrated embodiment, the instrument **875** includes a pressure sensor configured to monitor a pressure within a lumen in which the instrument **875** is positioned. The instrument **875** is in communication with an interface **876** via connection **877**. In some instances, interface **876** is a hemodynamic monitoring system or other control device, such as Siemens AXIOM Sensis, Mennen Horizon XVu, and Philips Xper IM Physio-monitoring 5. In one particular embodiment, instrument **875** is a pressure-sensing catheter that includes fluid column extending along its length. In such an embodiment, interface **876** includes a hemostasis valve fluidly coupled to the fluid column of the catheter, a manifold fluidly coupled to the hemostasis valve, and tubing extending between the components as necessary to fluidly couple the components. In that regard, the fluid column of the catheter is in fluid communication with a pressure sensor via the valve, manifold, and tubing. In some instances, the pressure sensor is part of interface **876**. In other instances, the pressure sensor is a separate component positioned between the instrument **875** and the interface **876**. The interface **876** is communicatively coupled to the computing device **872** via a connection **878**.

[0069] Similar to the connections between instrument **852** and the computing device **872**, interface **876** and connections **877** and **878** facilitate communication between the one or more sensors, transducers, and/or other monitoring elements of the instrument **875** and the computing device **872**. However, this communication pathway is exemplary in nature and should not be considered limiting in any way. In that regard, it is understood that any communication pathway between the instrument **875** and the computing device **872** may be utilized, including physical connections (including electrical, optical, and/or fluid connections), wireless connections, and/or combinations thereof. In that regard, it is understood that the connection **878** is wireless in some instances. In some instances, the connection **878** includes a communication link over a network (e.g., intranet, internet, telecommunications network, and/or other network). In that regard, it is understood that the computing device **872** is positioned remote from an operating area where the instrument **875** is being used in some instances. Having the connection **878** include a connection over a network can facilitate communication between the instrument **875** and the remote computing device **872** regardless of whether the computing device is in an adjacent room, an adjacent building, or in a different state/country. Further, it is understood that the communication pathway between the instrument **875** and the computing device **872** is a secure connection in some instances. Further still, it is understood that, in some instances, the data communicated

over one or more portions of the communication pathway between the instrument **875** and the computing device **872** is encrypted.

[0070] It is understood that one or more components of the system **850** are not included, are implemented in a different arrangement/order, and/or are replaced with an alternative device/mechanism in other embodiments of the present disclosure. For example, in some instances, the system **850** does not include interface **870** and/or interface **876**. In such instances, the connector **868** (or other similar connector in communication with instrument **852** or instrument **875**) may plug into a port associated with computing device **872**. Alternatively, the instruments **852**, **875** may communicate wirelessly with the computing device **872**. Generally speaking, the communication pathway between either or both of the instruments **852**, **875** and the computing device **872** may have no intermediate nodes (i.e., a direct connection), one intermediate node between the instrument and the computing device, or a plurality of intermediate nodes between the instrument and the computing device. The system **850** can additionally include a bedside interface, such as the bedside interface of medical sensing system **100** (FIG. 1). The bedside interface may be utilized by a clinician to control instruments **852** and **875** to acquire pressure data during a procedure, watch real-time medical pressure measurements (e.g., visual representations of pressure data, such as pressure waveforms, numerical values, etc.), and interact with the obtained medical sensing data using the bedside interface. In that regard, the bedside interface can be communicatively coupled to the computing device **872**, the interfaces **870** and **876**, and/or the instruments **864** and **875**.

[0071] Referring again to FIG. 6, the method **600** begins at block **610** where pressure measurements are obtained using diagnostic instruments such as instruments **830**, **832**. The diagnostic instruments are also configured to obtain diagnostic information about the vessel **800**. In one embodiment, these instruments **830**, **320** are sized and shaped to allow positioning of the at least one element configured to monitor pressure within the vessel **800** to be positioned proximal and/or distal of stenosis **808** as necessary based on the configuration of the devices. A variety of sensors may be integrated with this instrument, such as piezo-resistive pressure sensors, piezo-electric pressure sensors, capacitive pressure sensors, electromagnetic pressure sensors, a fluid column, optical pressure sensors, and/or combinations thereof.

[0072] In block **620**, the pressure measurement data is transmitted to a processing system. This processing system may take the form a computing device **872**. In some embodiments, the pressure measurement data may be sent directly to a PIM **112** or interface **870**. The transmission of data may be accomplished through a wired connection (using cable **866**) or a wireless connection. In that regard, the processing system may be positioned remote from an operating area where the diagnostic instrument is being used. Having the connection **874** include a connection over a network can facilitate communication between the diagnostic instrument and the processing system regardless of whether the computing device is in an adjacent room, an adjacent building, or in a different state/country. In typical embodiments, a processing system may collect raw pressure data from the diagnostic instrument and process the data to render visual representations of the obtained pressure data.

[0073] In block **630**, data is transmitted to the boom display **122** and bedside interface **202** to facilitate the display of

medical imagery. This medical imagery may be diagnostic visualizations and may include numerical, graphical, textual, and/or other suitable visualizations. The bedside interface **202** and boom display **122** retrieve the visual representations from the processing system and displays them to a user in real-time. As discussed above, a PIM **112** or interface **870** may be used in conjunction with a bedside interface **202** to display diagnostic representations to a clinician **107** or patient **106**.

[0074] In block **640**, the bedside interface **202** is used to display a close up region of interest. Specifically, the bedside interface may present pressure measurements or visual representations of the obtained pressure data on the bedside interface and the clinician **107** may navigate through them using gestures on the bedside interface's **202** touch panel. This close up region may show details not apparent in the more general display on the boom display **122**, and specified statistical data may accompany this close up display.

[0075] In block **650**, a clinician **107** analyzes the medical imagery or diagnostic visualization on the bedside interface **202**. The clinician analyzes the obtained pressure data or visual representations of the obtained pressure data, directly on the bedside interface **202**. For example, the user of the bedside interface interacts with the obtained pressure data or visual representations through a series of presses, moves and releases using a finger or stylus on the interface's touch-sensitive display. These actions are interpreted by the bedside interface's **202** internal processor. In some embodiments, the obtained pressure data and/or visual representations can be modified in response to the user touch inputs. For example, a user touch input on the bedside interface **202** can select a specific point of a pressure waveform that corresponds to a specific time at which pressure measurements were obtained. In another example, where diagnostic instruments take pressure measurements along the length of a vessel **800**, a user may be able to check pressure measurements associated with different sections of the vessel. In response to the user touch input, pressure data obtained at the specific time can be displayed proximate the specific point on the pressure waveform on the bedside interface. The clinician **107** may share the visualizations with a patient **106** at this step.

[0076] In block **660**, a clinician **700** plans a percutaneous coronary intervention based on the analysis with the bedside interface. The bedside interface may be used to place virtual markers on diagnostic visualizations, or to list pressure data to be used on the planning process. Additionally, diagnostic visualizations may be overlaid on images of a vessel displayed on the boom display **122** and/or bedside interface **202**. These diagnostic visualizations may assist the clinician **107** in determining the best available treatment options for a particular patient.

[0077] Persons skilled in the art will also recognize that the apparatus, systems, and methods described above can be modified in various ways. Accordingly, persons of ordinary skill in the art will appreciate that the embodiments encompassed by the present disclosure are not limited to the particular exemplary embodiments described above. In that regard, although illustrative embodiments have been shown and described, a wide range of modification, change, and substitution is contemplated in the foregoing disclosure. It is understood that such variations may be made to the foregoing without departing from the scope of the present disclosure.

Accordingly, it is appropriate that the appended claims be construed broadly and in a manner consistent with the present disclosure.

What is claimed is:

1. A method of planning the treatment of a vessel of a patient, comprising:

obtaining pressure measurements from first and second instruments positioned within a vessel of a patient during a diagnostic procedure where the second instrument is moved longitudinally through the vessel from a first position to a second position and the first instrument remains stationary within the vessel;

displaying on a first visualization device an image of the vessel with treatment diagnostic visualizations based on the obtained pressure measurements; and

displaying on a second visualization device a portion of the image of the vessel with diagnostic visualizations based on the obtained pressure measurements, wherein the portion of the image of the vessel displayed on the second visualization device is a close up of a region of interest of the vessel.

2. The method of claim 1, wherein the first and second visualization devices are utilized to guide placement of one or more treatment devices associated with the identified treatment option.

3. The method of claim 1, wherein the image displayed on the second visualization device is at a higher magnification than the image displayed on the first visualization device.

4. The method of claim 1, wherein the image of the vessel comprises an extravascular image and includes at least one of a two dimensional angiographic image, a three dimensional angiographic image, or a computed tomography angiographic (CTA) image.

5. The method of claim 1, wherein the image of the vessel comprises an intravascular image and includes at least one of an intravascular ultrasound (IVUS) image or an optical coherence tomography (OCT) image.

6. The method of claim 1, wherein the diagnostic visualizations include at least one of pressure measurements from the first instrument, pressure measurements from the second instrument, a ratio of the pressure measurements from the first and second instruments, an FFR value, or an iFR value.

7. The method of claim 1, wherein diagnostic visualizations include at least one of:

an intensity map based on changes in a pressure ratio of the obtained pressure measurements from the first and second instruments; or

a graph of a gradient of a pressure ratio of the obtained pressure measurements from the first and second instruments.

8. The method of claim 1, further comprising simulating a first treatment option, wherein simulating the first treatment option includes modifying the diagnostic visualizations based on an expected result of the first treatment option.

9. The method of claim 8, further comprising:

simulating a second treatment option, wherein simulating the second treatment option includes modifying the diagnostic visualizations based on an expected result of the second treatment option; and

comparing the modified diagnostic visualizations associated with the first and second treatment options to identify a recommended treatment option.

10. The method of claim 9, wherein the first and second treatment options are selected from the group consisting of

performing angioplasty, deploying one or more stents, applying a pharmaceutical agent, or combinations thereof.

11. A system of planning the treatment of a vessel of a patient, comprising:

a first instrument sized and shaped for introduction into the vessel of the patient;

a second instrument sized and shaped for introduction into the vessel of the patient;

a processing system in communication with the first and second instruments, the processing unit configured to:

obtain pressure measurements from first and second instruments positioned within a vessel of a patient during a diagnostic procedure where the second instrument is moved longitudinally through the vessel from a first position to a second position and the first instrument remains stationary within the vessel;

display on a first visualization device an image of the vessel with treatment diagnostic visualizations based on the obtained pressure measurements; and

display on a second visualization device a portion of the image of the vessel with diagnostic visualizations based on the obtained pressure measurements, wherein the portion of the image of the vessel displayed on the second visualization device is a close up of a region of interest of the vessel.

12. The system of claim 11, wherein the first and second visualization devices are utilized to guide placement of one or more treatment devices associated with the identified treatment option.

13. The system of claim 11, wherein the image displayed on the second visualization device is at a higher magnification than the image displayed on the first visualization device.

14. The system of claim 11, wherein the image of the vessel comprises an extravascular image and includes at least one of a two dimensional angiographic image, a three dimensional angiographic image, or a computed tomography angiographic (CTA) image.

15. The system of claim 11, wherein the image of the vessel comprises an intravascular image and includes at least one of an intravascular ultrasound (IVUS) image or an optical coherence tomography (OCT) image.

16. The system of claim 11, wherein the diagnostic visualizations include at least one of pressure measurements from the first instrument, pressure measurements from the second instrument, a ratio of the pressure measurements from the first and second instruments, an FFR value, or an iFR value.

17. The system of claim 11, wherein diagnostic visualizations include at least one of:

an intensity map based on changes in a pressure ratio of the obtained pressure measurements from the first and second instruments; or

a graph of a gradient of a pressure ratio of the obtained pressure measurements from the first and second instruments.

18. The system of claim 11, further comprising simulating a first treatment option, wherein simulating the first treatment option includes modifying the diagnostic visualizations based on an expected result of the first treatment option.

19. The system of claim 18, further comprising:

simulating a second treatment option, wherein simulating the second treatment option includes modifying the diagnostic visualizations based on an expected result of the second treatment option; and

comparing the modified diagnostic visualizations associated with the first and second treatment options to identify a recommended treatment option.

20. The system of claim **19**, wherein the first and second treatment options are selected from the group consisting of performing angioplasty, deploying one or more stents, applying a pharmaceutical agent, or combinations thereof.

* * * * *

专利名称(译)	床旁界面用于经皮冠状动脉介入治疗计划		
公开(公告)号	US20160166327A1	公开(公告)日	2016-06-16
申请号	US14/961541	申请日	2015-12-07
[标]申请(专利权)人(译)	火山公司		
申请(专利权)人(译)	火山CORPORATION		
当前申请(专利权)人(译)	火山CORPORATION		
[标]发明人	KELLER JACQUELINE		
发明人	KELLER, JACQUELINE		
IPC分类号	A61B19/00 A61B5/00 A61B6/00 A61B6/03 A61B8/08 A61F2/82 A61B5/0215 A61B8/12 G06F19/00		
CPC分类号	A61B19/50 A61B5/0215 A61B5/7445 A61B5/743 A61B6/504 A61B2019/501 A61B8/12 A61B8/0891 A61B5/0066 A61F2/82 A61B2019/507 A61B6/032 A61B5/0035 A61B5/004 A61B5/0084 A61B5/02007 A61B5/02158 A61B5/055 A61B5/6852 A61B5/6876 A61B6/12 A61B6/461 A61B6/469 A61B8/06 A61B8/5223 G06F3/0488 G06F19/30 G06F19/321 G16H40/63 G16H50/50 A61B34/10 A61B2034/101 A61B2034/107 G06F3/04815 G16H30/20 A61B5/7264		
优先权	62/089051 2014-12-08 US		
其他公开文献	US10660769		
外部链接	Espacenet USPTO		

摘要(译)

被配置为评估血管中阻塞的严重性，特别是血管狭窄的装置，系统和方法，提供允许评估血管的血管的测量值，特别是任何狭窄或病变的血管。容器，模拟诊断可视化第一可视化设备和第二可视化设备。例如，该方法可以包括在第一可视化装置上基于获得的压力测量结果在治疗诊断可视化上显示血管图像，并在第二可视化装置上显示具有基于诊断可视化的血管图像的一部分。在获得的压力测量值上，其中在第二可视化装置上显示的血管图像部分是血管的感兴趣区域的特写。

