



US 20140303461A1

(19) **United States**

(12) **Patent Application Publication**
Callaghan et al.

(10) **Pub. No.: US 2014/0303461 A1**
(43) **Pub. Date: Oct. 9, 2014**

(54) **APPARATUS AND METHODS FOR ACCESSING THE LYMPHATIC SYSTEM**

Publication Classification

(71) Applicants: **Matthew J. Callaghan**, Stanford, CA (US); **Stephen A. Leeftang**, Sunnyvale, CA (US); **Christian S. Eversull**, Palo Alto, CA (US)

(51) **Int. Cl.**
A61M 1/14 (2006.01)
A61M 25/04 (2006.01)
A61B 5/00 (2006.01)
A61M 1/00 (2006.01)

(72) Inventors: **Matthew J. Callaghan**, Stanford, CA (US); **Stephen A. Leeftang**, Sunnyvale, CA (US); **Christian S. Eversull**, Palo Alto, CA (US)

(52) **U.S. Cl.**
CPC *A61M 1/14* (2013.01); *A61M 1/008* (2013.01); *A61M 25/04* (2013.01); *A61B 5/41* (2013.01)
USPC . **600/309**; 604/27; 604/28; 604/506; 600/581

(21) Appl. No.: **14/214,882**

(22) Filed: **Mar. 15, 2014**

ABSTRACT

(57) Systems and methods are provided for performing a medical procedure within a patient's body that involves a thoracic duct including an ostium communicating with the patient's venous system. A distal end of a catheter is introduced through the patient's venous system into a body lumen adjacent the ostium of the thoracic duct. An expandable member on the distal end of the tubular member may be expanded adjacent the ostium, e.g., within the body lumen or the thoracic duct itself, and used to isolate the thoracic duct from the body lumen, whereupon a medical procedure may be performed via the thoracic duct. For example, lymphatic fluid may be removed from the thoracic duct through a lumen of the tubular member and/or one or more agents may be introduced into the thoracic duct through the tubular member.

Related U.S. Application Data

(63) Continuation-in-part of application No. 13/100,297, filed on May 3, 2011.
(60) Provisional application No. 61/800,161, filed on Mar. 15, 2013, provisional application No. 61/804,099, filed on Mar. 21, 2013.

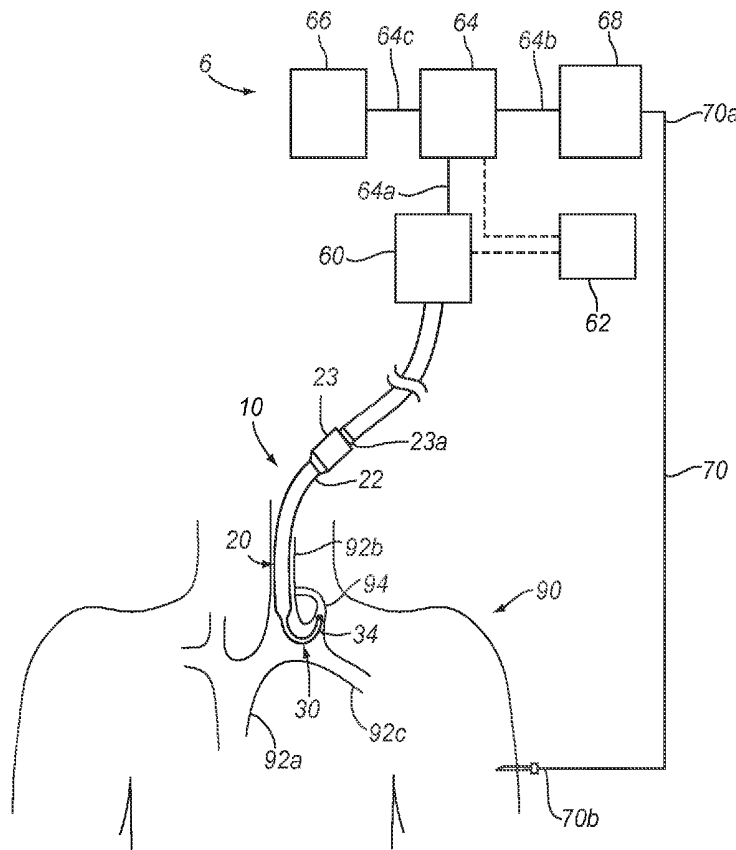

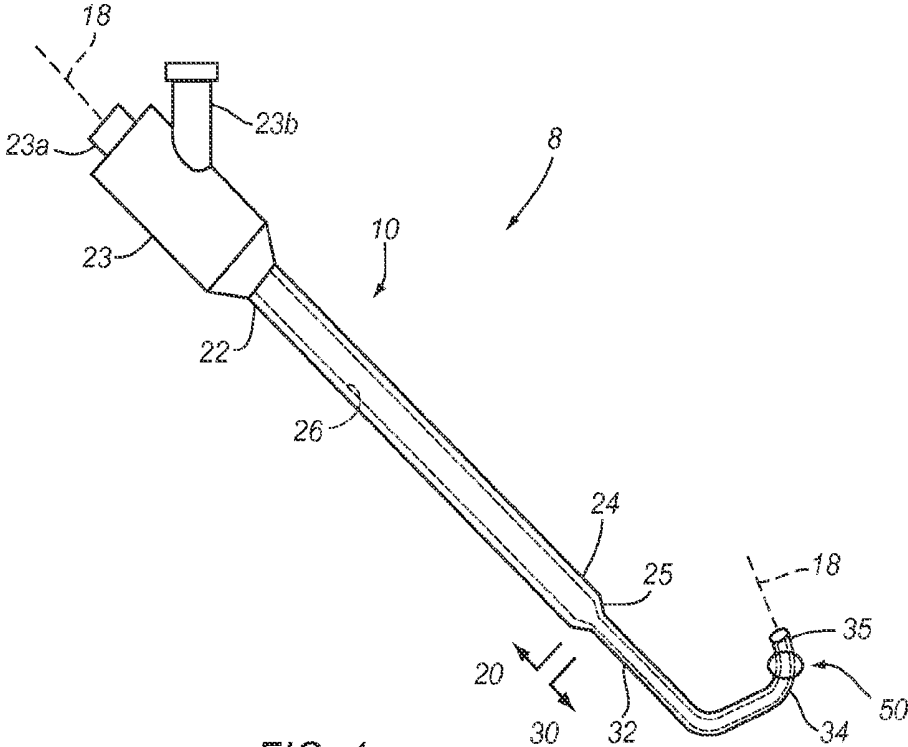

FIG. 1

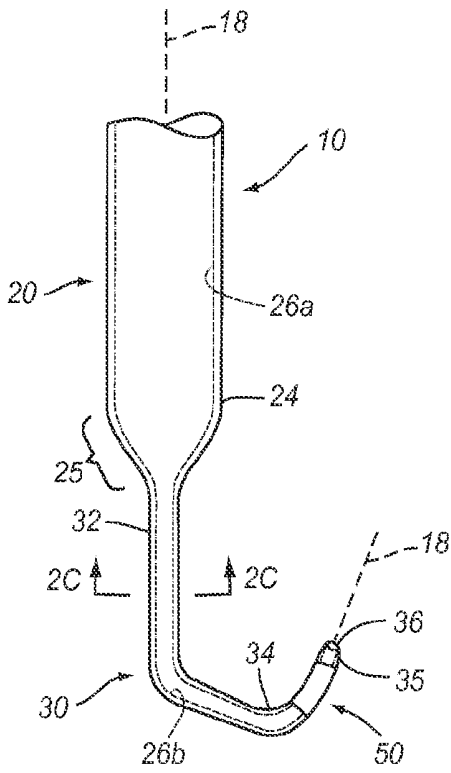

FIG. 2A

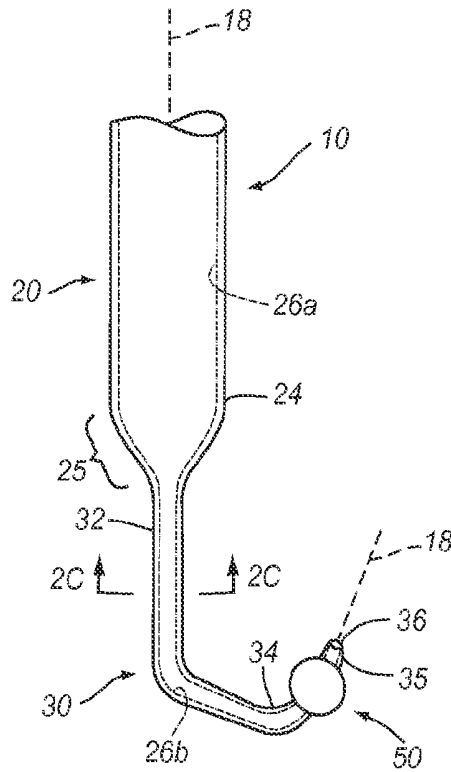

FIG. 2B

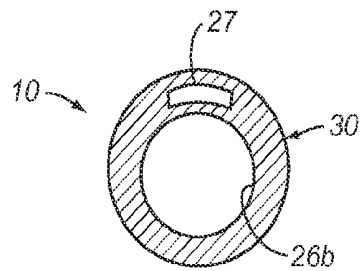

FIG. 2C

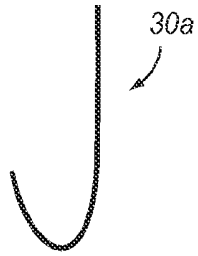

FIG. 3A

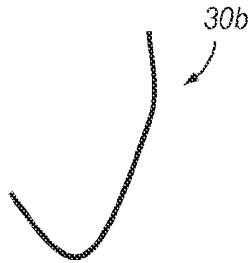

FIG. 3B

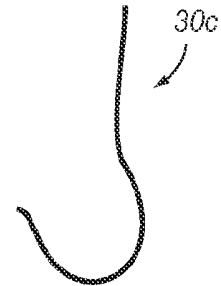

FIG. 3C

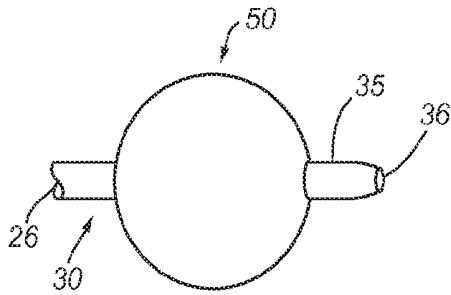

FIG. 4A

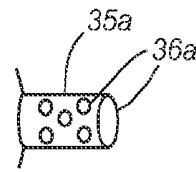

FIG. 4B

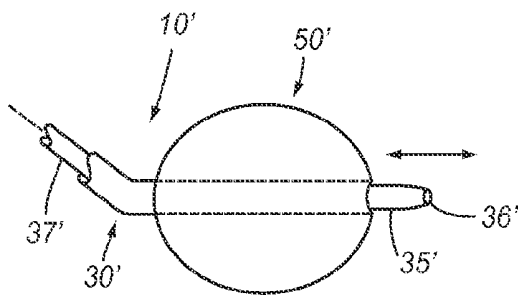

FIG. 4D

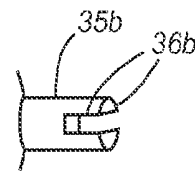

FIG. 4C

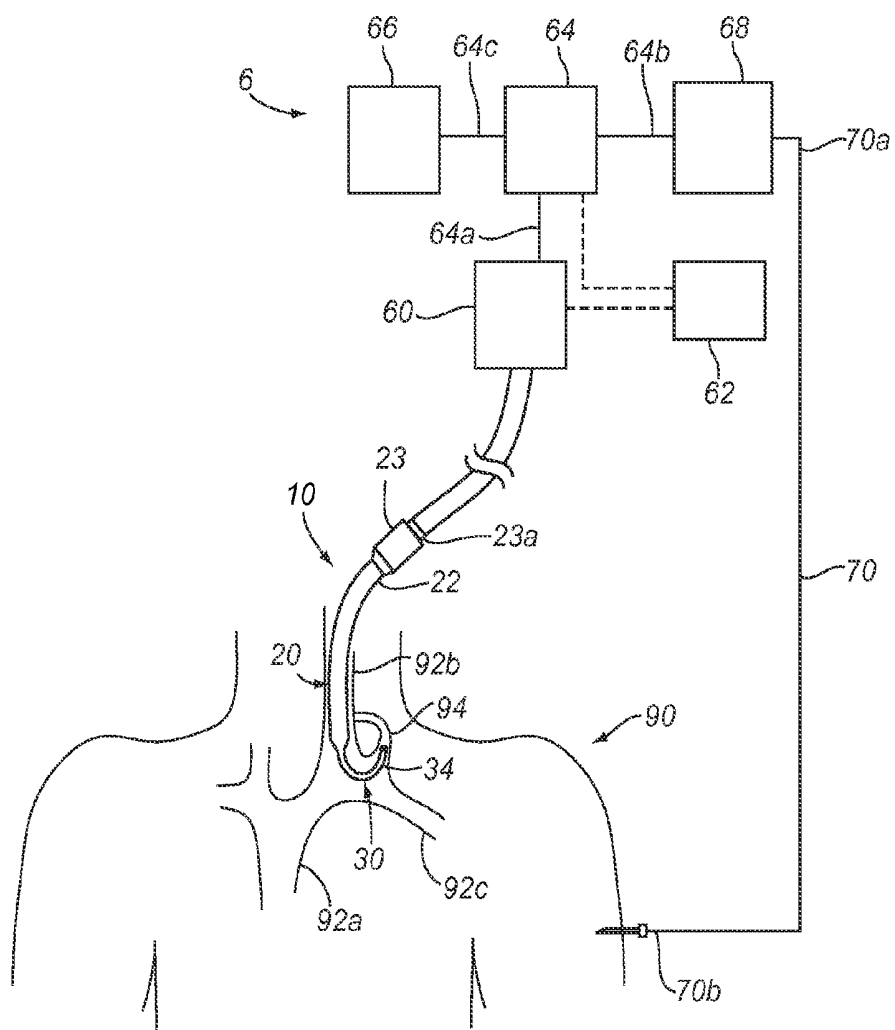

FIG. 5

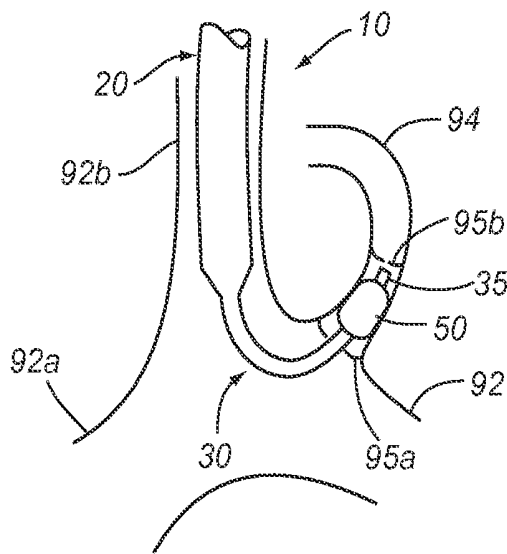

FIG. 6

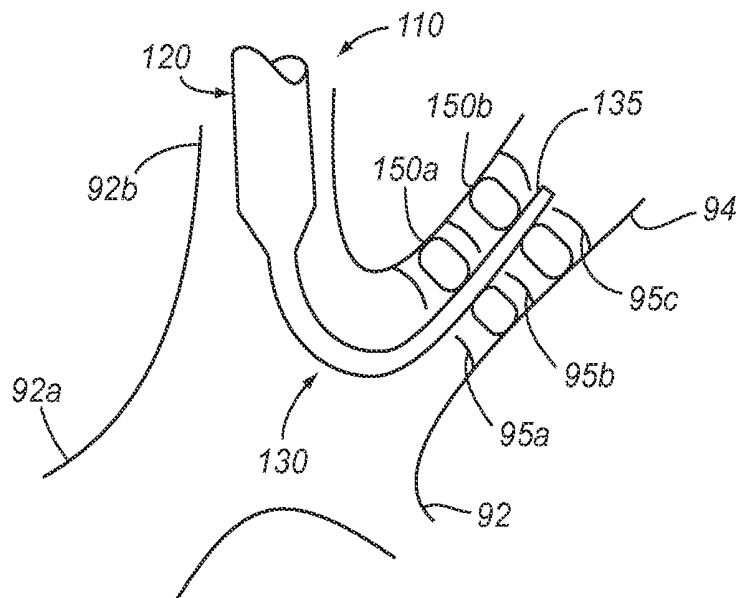

FIG. 7A

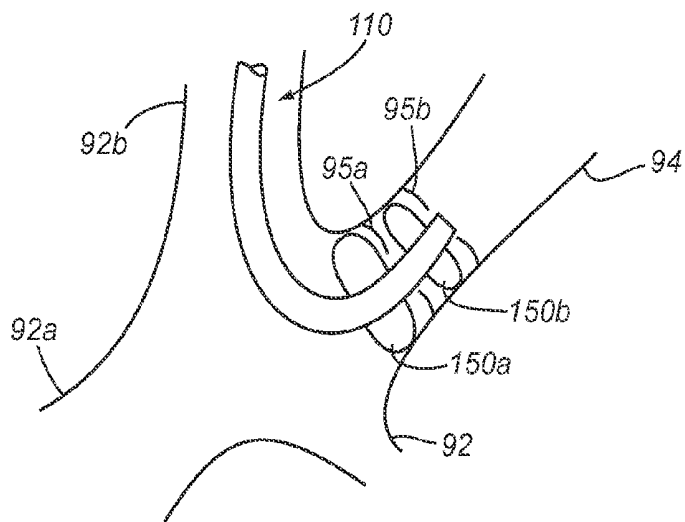

FIG. 7B

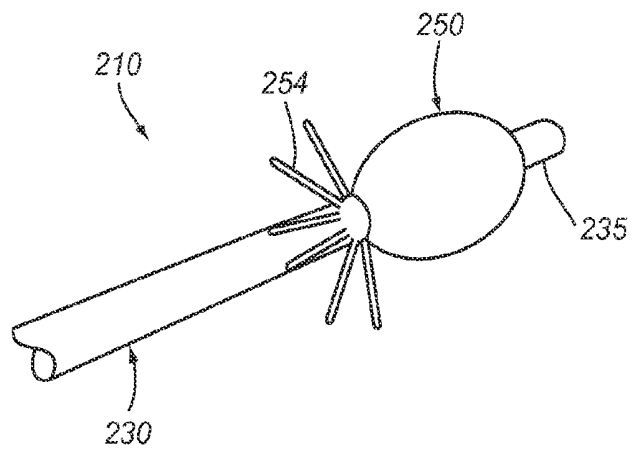

FIG. 8

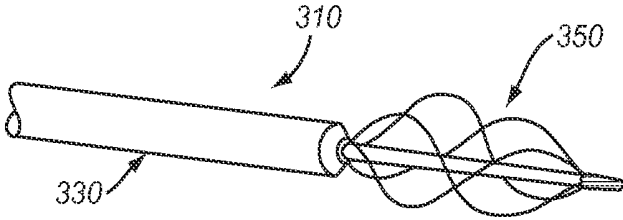

FIG. 9A

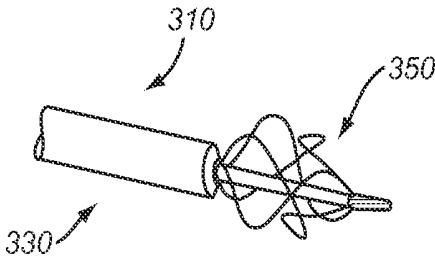

FIG. 9B

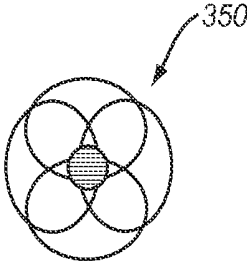

FIG. 9C

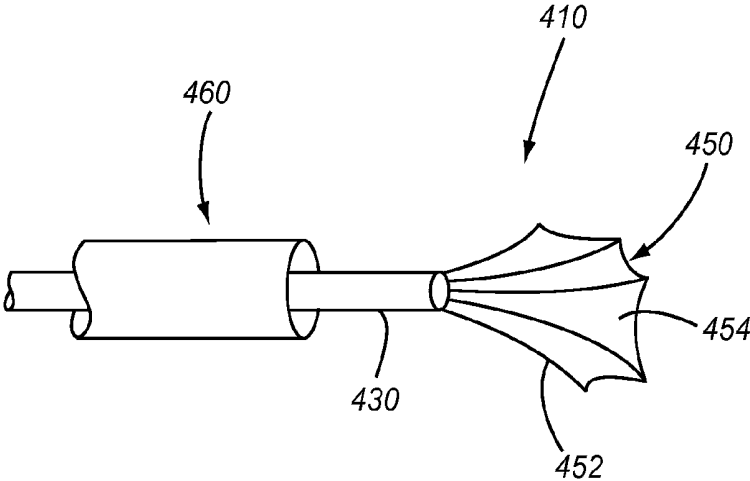

FIG. 10

APPARATUS AND METHODS FOR ACCESSING THE LYMPHATIC SYSTEM

[0001] This application claims benefit of co-pending provisional application Ser. No. 61/800,161, filed Mar. 15, 2013, and Ser. No. 61/804,099, filed Mar. 21, 2013, and is a continuation-in-part of co-pending application Ser. No. 13/100,297, filed May 3, 2011, which claims benefit of provisional application Ser. No. 61/642,180, filed May 3, 2012, the entire disclosures of which are expressly incorporated by reference herein.

FIELD OF THE INVENTION

[0002] The present invention relates generally to apparatus and methods used to perform medical procedures, and, more particularly, to devices, systems, and methods for accessing and/or otherwise involving the lymphatic system of a patient, e.g., to remove, separate, and/or re-infuse lymphatic fluid and/or other components of lymph.

BACKGROUND

[0003] The lymphatic system includes a network of vessels generally separate from veins and arteries. Rather than whole blood, the lymphatic vessels carry lymphatic fluid (or lymph). The lymphatic system serves a variety of physiologic purposes, including returning interstitial fluid to the vascular space, transporting fats from the digestive tract, and transporting immune-mediating cells. The composition of lymphatic fluid is similar to plasma. It contains white blood cells, but generally does not contain red blood cells, platelets, or various other components of whole blood. The lymphatic system may be involved in a variety of pathologic states, including lymphatic obstruction leading to lymphedema, leakage of lymphatic fluid, which may lead to chylothorax, or the invasion and spread of malignant cells leading to metastasis. The lymphatic system is involved in nearly any immune mediated response, whether to infectious agents (e.g., viruses, bacteria, parasites, etc.), malignancy, or in the setting of auto-immune disorders. The lymphatic system may serve as a repository for infected cells in disorders such as HIV or may contain a higher concentration of malfunctioning cells in various immune system disorders. To achieve diagnosis and/or treatment of these and other conditions, it may be desirable to access the lymphatic system.

SUMMARY

[0004] The present invention is directed generally to apparatus, systems, and methods for performing medical procedures, and, more particularly, to apparatus, systems, and methods for accessing the lymphatic system of a patient, e.g., to remove, separate, and/or re-infuse lymphatic fluid.

[0005] Historically, the lymphatic vessels have been accessed rarely, generally by direct approach. For example, some diagnostic procedures involve direct cannulation of peripheral lymphatic vessels, e.g., to infuse dye for identification of lymph nodes. Direct access of the central lymphatic vessels, such as the thoracic duct, is generally avoided. A defect, for example, in the thoracic duct generally does not readily close on its own, leading to significantly morbid conditions, such as chylothorax (persistent collection of lymphatic fluid around the lungs).

[0006] The lymphatic system does, however, eventually drain into the vasculature. A majority of lymphatic vessels

come to a confluence in the thoracic duct which generally enters the venous system at the junction of the left subclavian vein and the left internal jugular vein. A series of valves generally facilitate one-way flow of lymphatic fluid into the venous system and prevent reflux of whole blood into the thoracic duct. Although not well studied, disruption of one or more of these valves may have negative consequences. Therefore, it may be desirable to protect these valves and/or the lymphatic vessels themselves from damage.

[0007] Given the location of the thoracic duct, it may be feasible and desirable to access the lymphatic system by isolating or cannulating the thoracic duct via the venous system. Accessing the lymphatic vessels and removing and processing lymphatic fluid may be achieved using specialized catheter-based systems, as described elsewhere herein. Venous access may be achieved from any suitable location, including the left or right internal or external jugular, subclavian, axillary, anterior cubital, or femoral veins. Navigation to the thoracic duct may be aided by ultrasound, fluoroscopy, direct visualization, MRI, CT, and/or other imaging.

[0008] When accessing the lymphatic system transvenously, it may be desirable to substantially isolate the thoracic duct or other lymphatic vessel, e.g., in order to selectively remove lymphatic fluid without removing significant amounts of whole blood, and/or to introduce fluids, agents, and the like selectively into the lymphatic vessels. It may also be desirable to selectively remove a portion or component of lymphatic fluid that is unneeded or pathologic and re-infuse the remaining portion back into the body, for example, cells, protein, viruses, and/or other extracellular material.

[0009] Potential clinical applications may include drainage of lymphatic fluid for treatment of volume overload, for example, in the setting of congestive heart failure, depletion of lymphocytes or other immune system constituents, for example, in the setting of auto-immune disorders, preparation for transplantation procedures, treatment of infections residing primarily in immune-mediating cells, decompression of the lymphatic system to facilitate closure of leaking lymphatic vessels, treatment of lymphatic obstruction, and/or to otherwise remove fluid volume or pathologic constituents of lymphatic fluid. Further clinical applications may include diagnosis and/or monitoring of malignancy or metastatic spread of malignant cells, or treatment of infection or malignancy, for example, by infusion of antibiotic, antiviral, anti-parasitic, and/or chemotherapeutic agents directly into the lymphatic system. Other applications may include removal and treatment or modification ex-vivo of cells or other components of lymph followed by reinfusion, rapid immunization by direct introduction of antigens and/or antigenic material into the lymphatic system, or other applications where sampling or removal of lymphatic fluid or infusion of diagnostic or therapeutic agents is beneficial.

[0010] In accordance with an exemplary embodiment, an apparatus is provided for accessing a thoracic duct of a patient's body that includes a tubular member comprising a flexible, substantially straight proximal portion and a flexible, curved distal portion, wherein the proximal portion has a first length and a first outer diameter, and the distal portion has a second length and a second outer diameter, the second length shorter than the first length and the second outer diameter is smaller than the first outer diameter; and a balloon on the distal portion adjacent a distal tip thereof, the balloon sized for substantially isolating the thoracic duct when expanded therein.

[0011] In accordance with still another embodiment, an apparatus is provided for accessing a thoracic duct of a patient's body that includes a tubular member comprising a flexible, substantially straight proximal portion sized for introduction into a vein and a flexible, curved distal portion sized for introduction into a thoracic duct, and an aspiration lumen extending from a proximal end of the proximal portion to one or more inlet ports on a distal tip of the distal portion; and an expandable member on the distal portion adjacent the distal tip, the expandable member expandable from a collapsed configuration to allow introduction into a thoracic duct and an expandable configuration for substantially isolating the thoracic duct when expanded therein. In addition, the distal portion and the proximal portion may have one or more of the following: a) wherein the proximal portion has a first length and the distal portion has a second length, the second length shorter than the first length; b) wherein the proximal portion has a first outer diameter, and the distal portion has a second outer diameter, the second outer diameter is smaller than the first outer diameter; c) wherein the distal portion has greater flexibility than the proximal portion; d) wherein the distal portion is formed from softer materials than the proximal portion; and e) wherein the aspiration lumen has a first inner cross-section in the proximal portion and a second inner cross-section in the distal portion, the second cross-section smaller than the first inner cross-section.

[0012] In accordance with yet another embodiment, a method is provided for accessing a thoracic duct of a patient's body that includes providing a tubular member comprising a proximal portion and a flexible distal portion having a curvilinear shape in a relaxed state and terminating in a distal tip, the distal portion having a smaller outer diameter than the proximal portion; introducing the tubular member into a patient's vasculature via a percutaneous access site in the patient's left internal jugular vein; advancing the tubular member until the distal portion is disposed within a junction of the left internal jugular vein and the patient's left subclavian vein and the proximal portion is disposed through the access site and in the left internal jugular vein; manipulating the tubular member to orient the distal tip towards the thoracic duct; retracting the tubular member to direct the distal tip into the thoracic duct beyond a terminal valve of the thoracic duct; and expanding an expandable member on the distal portion adjacent the distal tip within the thoracic duct beyond the terminal valve to substantially isolate the thoracic duct from the left internal jugular vein and left subclavian vein.

[0013] In accordance with still another embodiment, a method is provided for accessing a thoracic duct of a patient's body that includes providing a tubular member comprising a proximal portion and a flexible distal portion having a curvilinear shape in a relaxed state and terminating in a distal tip, the distal portion having a smaller outer diameter than the proximal portion; introducing the tubular member into a patient's vasculature; advancing the tubular member until the distal portion is disposed within a junction of the left internal jugular vein and the patient's left subclavian vein; manipulating the tubular member to orient the distal tip towards the thoracic duct; retracting the tubular member to direct the distal tip into the thoracic duct beyond a terminal valve of the thoracic duct; and expanding an expandable member on the distal portion adjacent the distal tip within the thoracic duct beyond the terminal valve to substantially isolate the thoracic duct from the left internal jugular vein and left subclavian vein.

[0014] In accordance with another embodiment, a method is provided for performing a medical procedure within a patient's body, the body comprising a thoracic duct including an ostium communicating with the patient's venous system that includes introducing a distal portion of a tubular member through the patient's venous system into a body lumen adjacent the ostium of the thoracic duct, the distal portion biased to a curvilinear configuration; manipulating the tubular member until a distal tip of the distal portion enters the ostium of the thoracic duct; retracting the tubular member to direct the distal portion into the thoracic duct until an expandable member on the distal portion passes through a terminal valve of the thoracic duct; expanding the expandable member within the thoracic duct beyond the terminal valve to substantially isolate the thoracic duct from the body lumen; and performing a medical procedure via the thoracic duct.

[0015] In accordance with yet another embodiment, a system is provided for performing a medical procedure via a thoracic duct of a patient's body that includes a catheter or other tubular member including a proximal end, a distal end sized for introduction into a body lumen, and an aspiration lumen extending from the proximal end to a port in the distal end. An expandable member may be provided on the distal end, e.g., sized and/or shaped for substantially isolating the thoracic duct when expanded within the body lumen or thoracic duct itself. One or more external components, i.e., outside the patient's body, may be coupled to the proximal end of the tubular member, e.g., a source of vacuum for removing fluid within the body lumen via the port and aspiration lumen, a detector for analyzing the fluid removed from the body lumen to identify lymphatic fluid, a separator for separating the lymphatic fluid or components of the lymphatic fluid from other fluid in the fluid removed from the body lumen, and/or a container for collecting the lymphatic fluid or components of the lymphatic fluid separated from other fluid.

[0016] In accordance with another embodiment, a method is provided for performing a medical procedure within a patient's body that includes a thoracic duct including an ostium communicating with the patient's venous system. A distal end of a tubular member may be introduced through the patient's venous system into a body lumen adjacent the ostium of the thoracic duct. An expandable member on the distal end of the tubular member may be expanded adjacent the ostium, e.g., within the body lumen or the thoracic duct itself, and used to substantially isolate the thoracic duct from the body lumen, whereupon a medical procedure may be performed via the thoracic duct. For example, lymphatic fluid may be removed from the thoracic duct through a lumen of the tubular member and/or one or more agents may be introduced into the thoracic duct through the tubular member.

[0017] In an exemplary embodiment, fluid may be removed from the patient's body through a lumen of the tubular member, and the removed fluid may be analyzed to determine whether the fluid comprises lymphatic fluid or blood. For example, if the fluid comprises blood, the thoracic duct may not be isolated from the body lumen, and the removal of fluid may be stopped and/or the fluid may be directed to a waste container. If the fluid is lymphatic fluid, the fluid may be directed to a storage container, or components of the lymphatic fluid may be separated from other components of the fluid, and the separated components may be directed to a storage container. Optionally, the stored lymphatic fluid or the separated components of the lymphatic fluid may be

infused back into the patient's body, if desired, e.g., in a continuous or oscillatory fashion.

[0018] In accordance with another embodiment, a method is provided for performing a medical procedure within a patient's body that includes a thoracic duct including an ostium communicating with the patient's venous system. A distal end of a tubular member may be introduced through the patient's venous system into a body lumen adjacent the ostium of the thoracic duct. A first expandable member on the distal end of the tubular member may be introduced into the ostium and past a first valve of the thoracic duct. The first expandable member may be expanded within the thoracic duct beyond the first valve, e.g., to substantially isolate the thoracic duct from the body lumen, and a medical procedure may be performed via the thoracic duct.

[0019] Optionally, the tubular member may include a second expandable member adjacent the first expandable member. In one embodiment, the second expandable member is located distal to the first expandable member, and the second expandable member may be introduced into the ostium past a second valve of the thoracic duct when the first expandable member is introduced past the first valve of the thoracic duct, e.g., such that the first and second expandable members are positioned on either side of the second valve. In another embodiment, the second expandable member is located proximal to the first expandable member, and the second expandable member may be positioned within the ostium when the first expandable member is introduced past the first valve of the thoracic duct, e.g., such that the first and second expandable members are positioned on either side of the first valve.

[0020] In exemplary embodiments, the method may include removing lymphatic fluid from the thoracic duct through a lumen of the tubular member and/or one or more agents may be introduced into the thoracic duct through the tubular member.

[0021] In accordance with another embodiment, a method is provided for treating a patient via a thoracic duct of the patient's body that includes providing a tubular member comprising a proximal end, a distal end sized for introduction into the patient's body, and an expandable member on the distal end; introducing the distal end of the tubular member into the patient's vasculature via a percutaneous access site with the expandable member in a contracted condition; advancing the tubular member until the distal end is disposed within the thoracic duct; expanding an expandable member on the distal portion adjacent the distal tip to substantially isolate the thoracic duct from the patient's venous system; removing lymphatic fluid from the thoracic duct through the tubular member to a location exterior to the patient's body; and returning at least a portion of the lymphatic fluid back into the patient's body.

[0022] For example, the removed lymphatic fluid may be treated outside the patient's body, and the at least a portion of the lymphatic fluid may be returned back into the patient's body, e.g., into the thoracic duct through the tubular member or into another location within the patient's vasculature. In an exemplary embodiment, at least a portion of the lymphatic fluid is returned to treat sepsis within the patient's body, and treating the removed lymphatic fluid may include one or more of: a) performing leukofiltration of the removed lymphatic fluid before returning the lymphatic fluid to the patient's body to decrease immune response by the patient's body; b) filtering at least one of antibodies, interleukins (IL), and mediators

before returning the lymphatic fluid to the patient's body to decrease t-cell activation by the patient's body; and c) performing dialysis on the removed lymphatic fluid to remove at least one of toxins and non-cellular mediators before returning the lymphatic fluid to the patient's body.

[0023] In another embodiment, at least one type of cell found in the circulating lymph removed from the thoracic duct may be isolated and expanded outside the body. Gene therapy, drug treatment, and/or other manipulations may be performed on this expanded culture, and the treated cells may be re-infused via the thoracic duct or central venous system. In this example, the same device used to remove lymph may be used to re-infuse cells. Ex-vivo manipulation (i.e., with devices exterior to the patient's body) may take place within a closed circuit system circulating between the thoracic duct and the cardiovascular system, specifically the central venous system or arterial system. Ex-vivo manipulation may also take place away from the body. Re-infusion may occur in parallel (at the same time) as removal of lymph or in separate sessions over time.

[0024] In another embodiment, at least a portion of the lymphatic fluid is returned to treat HIV or other viral infection within the patient's body, and treating the removed lymphatic fluid may include at least one of: a) separating t-cells from the fluid and wherein the at least a portion of the lymphatic fluid returned to the patient's body comprises the separated t-cells; and b) separating protein from the fluid and wherein the at least a portion of the lymphatic fluid returned to the patient's body comprises the separated protein. In yet another embodiment, at least a portion of the lymphatic fluid is returned to treat HIV or other viral infection within the patient's body, and wherein treating the removed lymphatic fluid comprises: a) analyzing the removed lymphatic fluid to detect latently infected cell populations of the patient; and b) at least one or filtering, destroying, eliminating, and passivating the latently infected cell populations. In still another embodiment, at least a portion of the lymphatic fluid is returned to treat HIV or other viral infection within the patient's body, and treating the removed lymphatic fluid to the patient's body may include adding one or more compounds to the removed lymphatic fluid, and wherein the removed lymphatic fluid with the one or more added compounds are infused back into the patient's body to push the patient towards a virus-free equilibrium or restore natural immune function after suppression.

[0025] In accordance with still another embodiment, a method is provided for treating a patient via a thoracic duct of the patient's body that includes providing a tubular member comprising a proximal end, a distal end sized for introduction into the patient's body, and an expandable member on the distal end; introducing the distal end of the tubular member into the patient's vasculature via a percutaneous access site with the expandable member in a contracted condition; advancing the tubular member until the distal end is disposed within the thoracic duct; expanding an expandable member on the distal portion adjacent the distal tip to substantially isolate the thoracic duct from the patient's venous system; and removing lymphatic fluid from the thoracic duct through the tubular member to a location exterior to the patient's body.

[0026] In one embodiment, the lymphatic fluid is removed to reduce volume of interstitial fluid within the patient's body, e.g., to reduce portal pressure within the patient's portal vein, to treat esophageal varicities, and/or to treat ascites; or to manage hepatorenal syndrome. In another embodiment, lymphatic fluid may be removed from the thoracic duct periodi-

cally or intermittently to titrate the fluid to a desired level or amount, e.g., to achieve a desired lymph parameter and/or to maintain a desired systemic parameter of the patient. In still another embodiment, lymphatic fluid is removed from the thoracic duct for fluid management of the patient during a surgical procedure, such as a bypass procedure.

[0027] In accordance with yet another embodiment, a method is provided for treating a patient via a thoracic duct of the patient's body that includes providing a tubular member comprising a proximal end, a distal end sized for introduction into the patient's body, and an expandable member on the distal end; introducing the distal end of the tubular member into the patient's vasculature via a percutaneous access site with the expandable member in a contracted condition; advancing the tubular member until the distal end is disposed within the thoracic duct; expanding an expandable member on the distal portion adjacent the distal tip to substantially isolate the thoracic duct from the patient's venous system; removing lymphatic fluid from the thoracic duct through the tubular member to a location exterior to the patient's body; and analyzing the removed lymphatic fluid to monitor one or more parameters of the patient. For example, a composite assay of the removed lymphatic fluid may be generated to provide a snapshot of the immune system of the patient, one or more parameters of the removed lymphatic fluid may be compared with other parameters of the patient to diagnose a medical condition, at least one oft-cell population and status in the fluid may be assayed to monitor changes indicating function or rejection of an implant, and/or one or more parameters may be monitored to identify antagonistic t-cells to indicate that treatment of an autoimmune condition is needed. Alternatively, the removed lymphatic fluid may be analyzed to monitor a cancer status of the patient or to monitor one or more indicators of cancer metastasis of the patient, e.g., by identifying at least one of type oft-cells and number oft-cells in the fluid to diagnose remission or recurrence of cancer within the patient's body or quantifying tumor antigens or mediators in the fluid to determine the cancer status of the patient.

[0028] In accordance with still another embodiment, a method is provided for treating a patient via a thoracic duct of the patient's body that includes providing a tubular member comprising a proximal end, a distal end sized for introduction into the patient's body, and an expandable member on the distal end; introducing the distal end of the tubular member into the patient's vasculature via a percutaneous access site with the expandable member in a contracted condition; advancing the tubular member until the distal end is disposed within the thoracic duct; expanding an expandable member on the distal portion adjacent the distal tip to substantially isolate the thoracic duct from the patient's venous system; and infusing one or more fluids into the thoracic duct through the tubular member, e.g., in an oscillatory fashion.

[0029] For example, in one embodiment, one or more medications and/or biologics may be infused into the thoracic duct through the tubular member to stimulate growth to treat lymphedema within the patient's lymphatic system. In another embodiment, contrast may be infused through the tubular member into the thoracic duct, and the patient's lymphatic system may be imaged to diagnose chylothorax. For example, the imaging may facilitate identifying a target site having a breach within the patient's lymphatic system, and a

repair device may be introduced into the thoracic duct to repair the breach at the target site, e.g., a prosthesis and/or sealing material.

[0030] In accordance with an exemplary embodiment, a system and method are provided for treating a patient via a thoracic duct of the patient's body that include providing a tubular member comprising a proximal end, a distal end sized for introduction into the patient's body, and an expandable member on the distal end; introducing the distal end of the tubular member into the patient's vasculature via a percutaneous access site with the expandable member in a contracted condition; advancing the tubular member until the distal end is disposed within a junction of the patient's left internal jugular vein and left subclavian vein; manipulating the tubular member to direct the distal end into the thoracic duct; expanding an expandable member on the distal portion adjacent the distal tip to substantially isolate the thoracic duct from the left internal jugular vein and left subclavian vein; removing lymphatic fluid from the thoracic duct through the tubular member to a location exterior to the patient's body; treating the removed lymphatic fluid; and returning at least a portion of the lymphatic fluid back into the patient's body.

[0031] In accordance with another embodiment, a system and method are provided for diagnosing, monitoring, or treating a patient via a thoracic duct of the patient's body that include providing a tubular member comprising a proximal end, a distal end sized for introduction into the patient's body, and an expandable member on the distal end; introducing the distal end of the tubular member into the patient's vasculature via a percutaneous access site with the expandable member in a contracted condition; advancing the tubular member until the distal end is disposed within a junction of the patient's left internal jugular vein and left subclavian vein; manipulating the tubular member to direct the distal end into the thoracic duct; expanding an expandable member on the distal portion adjacent the distal tip to substantially isolate the thoracic duct from the left internal jugular vein and left subclavian vein; removing lymphatic fluid from the thoracic duct through the tubular member to a location exterior to the patient's body; and analyzing the removed lymphatic fluid to monitor one or more parameters of the patient.

[0032] Other aspects and features of the need for and use of the present invention will become apparent from consideration of the following description taken in conjunction with the accompanying drawings.

BRIEF DESCRIPTION OF THE DRAWINGS

[0033] It will be appreciated that the exemplary apparatus shown in the drawings are not necessarily drawn to scale, with emphasis instead being placed on illustrating the various aspects and features of the illustrated embodiments. The drawings illustrate exemplary embodiments of the invention, in which:

[0034] FIG. 1 is a perspective view of an exemplary apparatus of an apparatus for accessing a thoracic duct.

[0035] FIGS. 2A and 2B are details of a distal portion of the apparatus of FIG. 1, showing a balloon on the distal portion in collapsed and enlarged configurations, respectively.

[0036] FIG. 2C is a cross-section of the distal portion of the apparatus of FIGS. 2A-2B taken along line 2C-2C.

[0037] FIGS. 3A-3C are schematic views showing alternative relaxed shapes for the distal portion of an apparatus, such as that shown in FIG. 1.

[0038] FIGS. 4A-4C are details of alternative embodiments of distal tips that may be provided on an apparatus, such as that shown in FIGS. 1-2B.

[0039] FIG. 4D is a detail of another alternative embodiment of a retractable/advanceable distal tip that may be provided on an apparatus, such as that shown in FIGS. 1-2B.

[0040] FIG. 5 is a detail of a patient's body showing a schematic of an exemplary system for accessing the lymphatic system of the patient including an apparatus, such as that shown in FIGS. 1-2B.

[0041] FIG. 6 is a detail of a patient's body, showing the distal portion of a catheter positioned within a thoracic duct of the patient and with a balloon thereon inflated to substantially isolate the thoracic duct from the patient's venous system.

[0042] FIGS. 7A and 7B are details of a patient's body, showing a distal portion of another exemplary embodiment of an apparatus with a pair of balloons expanded within a thoracic duct of the patient on either side of a valve within the thoracic duct.

[0043] FIG. 8 is a detail showing a distal portion of another embodiment of a catheter including a plurality of expandable tines adjacent a balloon for anchoring the distal portion relative to a thoracic duct.

[0044] FIGS. 9A-9C are side and ends views of yet another embodiment of a catheter including a mechanically expandable member that is expandable from a collapsed configuration (FIG. 9A) to an enlarged configuration (FIGS. 9B and 9C) for isolating a thoracic duct.

[0045] FIG. 10 is a side view of still another embodiment of a catheter including an expandable umbrella/hood shown in an expanded configuration upon deployment from a delivery sheath.

DETAILED DESCRIPTION OF THE EXEMPLARY EMBODIMENTS

[0046] Turning to the drawings, FIGS. 1-2B show an exemplary embodiment of an apparatus 8 for accessing and/or isolating the lymphatic system of a patient 90 (not shown, see, e.g., FIG. 5 for anatomical references), e.g., to aspirate or otherwise draw lymphatic fluid from the thoracic duct 94, as described further below. Generally, the apparatus 8 includes a catheter or other tubular member 10 including a proximal or main portion 20, e.g., sized and/or shaped for introduction into a blood vessel of the patient, such as a jugular vein 92b (not shown, see FIG. 5), and a relatively smaller distal portion 30, e.g., sized and/or shaped for introduction into a thoracic duct 94 of the patient 90 (also not shown, see FIG. 5), thereby defining a central longitudinal axis 18 for the apparatus 8.

[0047] A balloon or other expandable member 50 may be provided on the distal portion 30, e.g., sized for introduction into a thoracic duct in a collapsed configuration and expandable to an enlarged configuration for substantially sealing and/or isolating the thoracic duct 94, as described further below. The balloon 50 may be formed from elastic material, e.g., such that the balloon 50 may be inflated to multiple diameters to accommodate engaging the wall of thoracic ducts of various sizes and/or shapes, to provide a substantially fluid-tight seal without applying excessive forces against the wall.

[0048] Generally, the proximal and distal portions 20, 30 of the catheter 10 have different dimensions and/or properties. For example, the proximal portion 20 may have a substantially straight shape in a relaxed state, yet may be sufficiently flexible to be introduced into a patient's body 90, e.g., suffi-

ciently flexible to be introduced into the venous system from a percutaneous access site, such as via a left or right internal or external jugular vein, subclavian vein, axillary vein, or other percutaneous access site. In an exemplary embodiment, access may be gained from the left internal jugular vein 92b to approach the junction of the left internal jugular vein 92b and left subclavian vein 92c, as shown in FIG. 5. The distal portion 30 may have a curvilinear shape in a relaxed state, e.g., a simple curved shape or a more complicated shape including one or more curved and/or straight sections, which may facilitate introduction of the distal portion 30 into the thoracic duct 94, e.g., from the jugular vein 92b, as described further below.

[0049] In addition or alternatively, the proximal portion 20 may be substantially longer than the distal portion 30, e.g., to allow the proximal portion 20 to be introduced into the patient's body from an access site, e.g., into the left internal jugular vein 92b, and manipulated to introduce the distal portion 30 into the thoracic duct 94. For example, as shown in FIG. 1, the proximal portion 20 may include a proximal end 22 including a handle or hub 23, and a distal end 24 coupled or otherwise including a transition 25 to the distal portion 30. In exemplary embodiments, the proximal portion 20 may have a length from the handle 23 to the transition 25 between about three and one hundred twenty centimeters (3.0-120 cm), or alternatively between about three and thirty centimeters (3.0-30.0 cm), and may have an outer diameter or other maximum cross-section between about one and seven millimeters (1.0-7.0 mm), or alternatively between about one and three millimeters (1.0-3.0 mm). The handle 23 may be larger than the proximal portion 20, e.g., having a shape and/or otherwise configured for holding and/or manipulating the catheter 10 from a location outside of a patient's body.

[0050] The transition 25 may include a tapered shape, as shown, an abrupt step-down shape (not shown), and the like to transition between the proximal and distal portions 20, 30. If the proximal and distal portions 20, 30 are formed from different materials, the transition 25 may connect the different materials together, e.g., by bonding with adhesive, fusing, sonic welding, heat forming, and the like.

[0051] The distal portion 30 may have a proximal end 32 extending distally from the transition 25, e.g., aligned substantially axially with the proximal portion 20, and a distal end 34 terminating in a distal tip 35. In exemplary embodiments, the distal portion 30 may have a length from the proximal end 32 to the distal tip 35 between about one and ten centimeters (1.0-10.0 cm), and may have an outer diameter or other maximum cross-section between about half to five millimeters (0.5-5.0 mm), or alternatively between about half and two millimeters (0.5-2.0 mm). Thus, the distal portion 30 may be substantially shorter than the proximal portion 20, e.g., such that the proximal portion 20 may extend from a percutaneous access site (not shown) into the junction of the left internal jugular vein 92b and the left subclavian vein 92c, and the distal portion 30 may simply curve and enter the thoracic duct 94, as described further elsewhere herein.

[0052] The distal portion 30 may have a substantially uniform outer diameter between the proximal end 32 and the distal tip 35, or the diameter may vary, e.g., tapering at or adjacent the distal tip 35 to provide a substantially atraumatic distal tip 35.

[0053] In addition, the distal portion 30 may have a flexibility greater than the proximal portion 20. For example, the proximal portion 20 may have sufficient column strength, stiffness, torque, and the like such that the proximal portion

20 may be manipulated from the handle **23** without substantial risk of the distal end **24** of the proximal portion **20** buckling or kinking, while providing sufficient flexibility to accommodate introduction into curved vessels within the patient's body. In exemplary embodiments, the proximal portion **20** may have a substantially rigid or semi-rigid proximal end **22**, e.g., to facilitate advancement of the distal portion from the handle **23**, while the distal end **24** may be semi-rigid or flexible. Moreover, the device properties may be optimized to responsively translate manipulation of the proximal end **22** into movement of the distal portion **30**, e.g. by means of rotation, torque, angular manipulation, withdrawal, and/or advancement.

[0054] The distal portion **30** may be substantially flexible, e.g., biased to the curvilinear shape when free from external forces, yet flexible to accommodate bending, compressing (of the distal tip **35** towards the proximal portion **20**), and/or other movement of the distal portion **30** to facilitate introducing the distal tip **35** into the thoracic duct. In exemplary embodiments, the distal portion **30** may be formed from PEBAX, urethane, silicone, and/or other soft and/or flexible materials, e.g., having substantially uniform properties along the length of the distal portion **30**, or becoming progressively (or otherwise) softer and/or more flexible from the proximal end **32** to the distal tip **35**. The proximal and distal portions **20**, **30** may be formed from different materials to provide the desired flexibility. For example, the proximal portion **20** may include a reinforcement layer, e.g., braiding and the like between inner and outer layers (not shown), while the distal portion **30** may simply include a single layer or vice versa. Alternatively, a different reinforcing layer (e.g. braid, coil, stent-like structure or other scaffolding) may be used in the proximal and distal portions **20**, **30**. For example, a reinforcing structure may include a laser-cut tubular structure (e.g., formed from Nitinol, stainless steel, cobalt chromium, and the like) having a structure that may accommodate a substantially straight shape and a desired curvilinear shape without substantial permanent deformation. Further, a reinforcing structure may be shape set (e.g., by heat treating, annealing, plastically deforming, and the like) in order to maintain a desired curvilinear shape in the distal portion **30**.

[0055] In addition or alternatively, relative flexibility may be obtained by providing different wall thicknesses, e.g., from the same or different materials. For example, as shown in FIGS. **2A** and **2B**, the proximal portion **20** may have a relatively larger wall thickness than the distal portion **30**, which may enhance relative flexibility of the distal portion **30**. In exemplary embodiments, the wall thickness of the proximal portion **20** may be between about 0.1 and three millimeters (0.1-3.0 mm), while the wall thickness of the distal portion **30** may be between about 0.1 and two millimeters (0.1-2.0 mm).

[0056] As shown in FIG. **1**, the distal portion **30** may include multiple substantially straight sections between curved sections, e.g., to provide a "hook" shape having an overall angle of curvature equal to or greater than ninety degrees, e.g., between about ninety and three hundred sixty degrees)(90-360°, or between about ninety and one hundred fifty degrees)(90-150°. Such radii of curvature may facilitate introduction into the thoracic duct **94**, which may connect near the junction of the jugular, subclavian, and brachiocephalic veins **92** at an acute angle, such that a radius of curvature greater than ninety degrees)(90° may be necessary to align the distal tip **35** with the thoracic duct **94** when the

proximal portion **20** is within the left internal jugular vein **92b**, as described further elsewhere herein.

[0057] In an alternative embodiment, shown in FIG. **3A**, the distal portion **30a** may include a single substantially continuous radius of curvature approaching one hundred eighty degrees)(180°. In a further alternative, shown in FIG. **3B**, the distal portion **30b** may have a more complicated curvilinear shape, e.g., including a first straight section between a bend and a radiused section ending in a substantially straight distal tip (which may carry a balloon, not shown). In yet another alternative, shown in FIG. **3C**, the distal portion **30c** may include a continuous curved shape including a first bend in an opposite direction to the main radius of curvature of the distal portion **30c**. Such shapes may orient the distal tip **35** of the catheter **10** back towards the proximal end **22** with the distal tip **35** defining a desired angle relative to the longitudinal axis **18** within the proximal portion **20**.

[0058] In still another alternative, the distal portion **30** may include a curved section of constant or variable radius having an arc angle of between about zero and three hundred sixty degrees)(0°-360° and a radius of curvature between about one and fifteen millimeters (1.0-15.0 mm). Further alternatively, the distal portion **30** may include one or more discrete bends, creating a distal shape having a width between about two and thirty millimeters (2.0-30.0 mm). More generally, any of the foregoing shapes may be optimized to locate the distal tip **35** at or near the thoracic duct ostium and simultaneously align the tip vector with the entry vector of the thoracic duct **94**. Furthermore, the shape of the distal portion **30** may be sufficiently resilient to return to its pre-set shape, e.g. after introduction through a sheath, repeated manipulation, and the like.

[0059] Optionally, the distal portion **30** may include one or more features to facilitate identification and/or localization of the distal portion **30**, e.g., the balloon **50** and/or distal tip **35**, within a patient's body using external imaging. For example, one or more echogenic features, may be provided on or in the wall of the balloon **50** and/or on the distal tip **35**, which may facilitate monitoring the distal portion **30** using ultrasound imaging. Such exemplary features may include doping or coating with tungsten, tungsten carbide, titanium dioxide, iron oxide, zinc oxide, platinum, gold, barium, bismuth, and/or titanium; echogenic surface modifications such as reflective gratings, surface depression and/or projections; inclusions, for example, of glass particles, air bubbles, and the like, including those described in U.S. Pat. No. 5,921,933, the entire disclosure of which is expressly incorporated by reference herein. Alternatively, radiopaque and/or other markers (also not shown) may be provided to facilitate monitoring the distal portion **30** using fluoroscopy or other external imaging.

[0060] Returning to FIGS. **1-2B**, the catheter **10** may include one or more lumens **26**, **27** extending therethrough, e.g., from the proximal end **22** of the proximal portion **20** to the distal portion **30**. For example, as shown in FIG. **1**, an aspiration or infusion lumen **26** may be provided that communicates with a port **23a** in the handle **23** and extends through the entire proximal and distal portions **20**, **30** to one or more inlet (or outlet) ports **36** adjacent the distal tip **35**. As best seen in FIGS. **2A** and **2B**, the aspiration lumen **26** may include a relatively large region **26a** within the proximal portion **20** and a relatively small region **26b** within the distal portion **30**. In exemplary embodiments, the proximal region **26a** of the lumen **26** may have an inner diameter (or other maximum cross-section) between about one and five millimeters (1.0-5.0 mm), while the distal region **26b** may have an

inner diameter (or other maximum cross-section) between about 0.1 and three millimeters (0.1-3.0 mm).

[0061] The smaller diameter of the distal region **26b** may allow the outer diameter of the distal portion **30** to be minimized, e.g., to provide desired flexibility and/or minimize the size of the distal portion **30** to facilitate introduction into the thoracic duct **94**, while the larger diameter of the proximal region **26a** may allow lymph or other fluids to be drawn through the catheter **10** more easily. For example, the larger diameter over most of the length of the catheter **10** may expose the fluid to lower friction, which may increase flow rate and/or reduce the risk of lysing or otherwise damaging cells or other components of the fluid being aspirated or delivered through the lumen **26** of the catheter **10**.

[0062] As shown in FIGS. **2A**, **2B**, and **4A**, the aspiration lumen **26** may communicate with a single inlet port **36** in the distal tip **35**, e.g., aligned with the central longitudinal axis **18**. Alternatively, multiple inlet ports may be provided on the distal tip, e.g., to reduce the risk of a single or multiple ports becoming occluded with fluid or debris and/or contacting and sucking the wall of the thoracic duct or other body lumen against the distal tip **35**, which may otherwise prevent fluid from being drawn into the lumen **26**. For example, as shown in FIG. **4B**, the distal tip **35a** may include a plurality of side ports in addition to the axial inlet port **36a**, or, as shown in FIG. **4C**, one or more slots (two shown) may be provided that extend partially from the axial inlet port **36b**.

[0063] In addition, turning to FIG. **2C**, the catheter **10** may include an inflation lumen **27**, e.g., extending through the proximal and distal portions **20**, **30** and communicating with an interior of the balloon **50**. The inflation lumen **27** may communicate with a port **23b** on the handle **23**, shown in FIG. **1**, which may allow a source of inflation and/or vacuum, e.g., a syringe and the like (not shown), to be coupled to the catheter **10** and communicate with the interior of the balloon **50**, e.g. to allow the balloon **50** to be inflated and collapsed, as described elsewhere herein. Alternatively, another expanded member, e.g., a mechanically expandable frame and the like (not shown, see, e.g., FIGS. **9A-9C**), may be provided on the distal portion **30** instead of the balloon **30**. In this alternative, a mechanical actuator, e.g., a slider, wheel, and the like (also not shown, may be provided on the handle **23** that is coupled to the frame or other expandable member for directing the expandable member between collapsed and enlarged configurations.

[0064] Optionally, the catheter **10** may include one or more additional lumens, if desired. For example, an infusion lumen (not shown) separate from the aspiration lumen **26** may be provided, which may allow infusion of fluids or agents through the catheter **10** to one or more outlets (also not shown) on the distal portion **30**, independent of aspiration or removal of fluid through the lumen **26**. Infusion of fluids may be into the thoracic duct **94** or into the vein(s) at any point along the course of the catheter **10**. Infused fluids may include at least some part or all of fluids aspirated by means of the same catheter. In addition, a guidewire lumen and/or a stylet lumen (not shown) may be provided that extends through the proximal portion **20** into the distal portion **30**, e.g., for at least partially straightening and/or supporting the distal portion **30** during introduction into a patient's body, as described elsewhere herein.

[0065] Turning to FIGS. **5** and **6**, the apparatus **8** may be used to perform a medical procedure within the patient's body **90** that includes accessing the thoracic duct **94**, which

may be related to any of the conditions and/or treatments described elsewhere herein. Initially, the catheter **10** may be introduced into the patient's body **90**, e.g., into the venous system from a percutaneous access site, such as the left or right internal or external jugular, subclavian, axillary, anterior cubital, or femoral veins.

[0066] To facilitate introduction and/or navigation of the catheter **10**, one or more other devices may be used in conjunction with the catheter **10**, if desired. For example, in one embodiment, a guidewire (not shown) may be introduced and advanced from the percutaneous access site, through any intervening vessels into the junction of the left internal jugular vein **92b** and left subclavian vein **92c**, and into the thoracic duct **94**. The guidewire may be backloaded into the inlet port **36** of the distal portion **30** and through the aspiration lumen **26** (or through a separate lumen, e.g., a dedicated guidewire lumen, not shown, if provided on the catheter **10**). The catheter **10** may then be advanced over the guidewire into the access site and intervening vessels, and at least the distal tip **35** of the distal portion **30** may be introduced into the thoracic duct **94**.

[0067] In addition or alternatively, other devices may be used to at least partially straighten and/or otherwise support the distal portion **30** of the catheter **10**. For example, a stylet (not shown) may be positioned within the catheter **10**, e.g., within the aspiration lumen **26** or a separate lumen (not shown) such that the stylet enters at least partially into the distal portion **30**, thereby directing the distal portion **30** from its relaxed curvilinear shape to a less curved or substantially straight configuration (not shown) and/or otherwise supporting the distal portion **30** from buckling or kinking. The distal portion **30** may then be introduced through the access site and any intervening vessels until the distal tip **35** is located adjacent the thoracic duct **94**, e.g., within the junction of the jugular and subclavian veins **92b**, **92c**. The stylet may be sufficiently flexible to accommodate introducing the distal portion **30** through any bends or tortuous anatomy encountered between the access site and the thoracic duct **94**. Once the distal tip **35** is located adjacent the thoracic duct **94**, e.g., within the junction of the left internal jugular vein **92b** and the left subclavian vein **92b**, the stylet may be removed, thereby allowing the distal portion **30** to return towards its relaxed, curvilinear configuration. Alternatively, one or more shaped stylets may be used to accentuate, alter, essentially create the shape of the distal portion **30**. Further, a stylet may be used to direct the distal portion **30** toward and/or into the thoracic duct **94**, e.g., by independent and/or co-manipulation (e.g. twisting, advancing, retracting) of the stylet and the catheter **10**.

[0068] In another alternative, a sleeve, sheath, cover, and the like (also not shown) may be provided over the catheter **10** until the distal portion **30** is sufficiently covered, e.g., to at least partially straighten and/or support the distal portion **30**. The distal portion **30** may then introduced into the patient's body **90** until the distal tip **35** is disposed adjacent the thoracic duct **94**, whereupon the cover may be removed to expose and release the distal portion **30**, again thereby allowing the distal portion **30** to return towards its relaxed, curvilinear configuration.

[0069] With the distal portion released or exposed within the junction, the proximal portion **20** of the catheter **10** may then be manipulated, e.g., advanced and/or retracted, rotated, and the like until the distal tip **35** enters the thoracic duct **94**, as shown in FIG. **5**. For example, without a guidewire, the

catheter 10 may be manipulated until the distal portion 30 “hooks” the ostium of the thoracic duct 94. Because of the soft and/or flexible nature of the distal portion 30, such manipulation may be completed without substantial risk of perforation or other damage to the vessels. In addition, given that the thoracic duct 94 may extend at an angle almost one hundred eighty degrees relative to the left internal jugular vein 92b, the angle of the distal portion 30 may facilitate orienting the distal tip 35 “backwards” towards the ostium of the thoracic duct 94.

[0070] Once the distal tip 35 is placed within the ostium of the thoracic duct 94, the catheter 10 may be retracted or otherwise manipulated to direct the distal portion 30 further into the thoracic duct 94. For example, if the catheter 10 is to be introduced into the left internal jugular vein 92b, as shown in FIG. 5, the length of the catheter 10 may be substantially shorter than most catheters, thereby providing a more direct relationship of movement between the proximal end 22 and the distal portion 30 since the catheter 10 is less likely to twist, compress, stretch, and the like between the proximal end 22 and the distal portion 30.

[0071] If the catheter 10 is manipulated to place the distal tip 35 at the ostium of the thoracic duct 94, the catheter 10 may simply be retracted (e.g., upwardly) to pull the distal tip 35 up into the thoracic duct 94, e.g., as shown in FIG. 6. In an exemplary embodiment, the distal portion 30 may pass through the terminal valve 95a of the thoracic duct 94 until the balloon 50 is positioned between the terminal valve 95a and the next valve 95b within the thoracic duct 94. The balloon 50 may then be inflated to engage the wall of the thoracic duct 94 and substantially seal and/or isolate the thoracic duct 94 from the veins 92.

[0072] Optionally, navigation to the thoracic duct 94 may be aided using external imaging, such as ultrasound imaging. For example, as described elsewhere herein, the distal portion 30 of the catheter 10 may include one or more echogenic features, which may facilitate identification and monitoring the balloon 50 and/or the distal tip 35. Because the thoracic duct 94 is located near the surface, i.e., close to the patient’s skin, an ultrasound imaging device placed on or near the patient’s skin may provide high resolution visualization of the region including the thoracic duct 94 and adjacent veins 92 to facilitate monitoring the distal portion 30 until the distal tip 35 and balloon 50 are positioned as desired.

[0073] In addition or alternatively, tactile feedback and/or manipulation may be used to facilitate positioning the distal portion 30. For example, given the close proximity of the thoracic duct 94 and neighboring veins 92 to the skin, it may be possible to feel the catheter 10 by placing the user’s fingers on the patient’s overlying skin and pressing against the skin and intervening tissues. Such pressure may also be used to physically manipulate the distal portion 30, e.g., in addition to manipulation of the proximal end 22, to direct the distal tip 35 into the thoracic duct 94.

[0074] In addition or alternatively, other imaging may be used, such as fluoroscopy, MRI, CT, and/or direct visualization, e.g., using an imaging element carried on the distal portion 30 of the catheter 10. Exemplary imaging elements and methods for using them are disclosed in U.S. Publication Nos. 2011/0034790, 2007/0015964, 2006/0084839, and 2004/0097788, the entire disclosures of which are expressly incorporated by reference herein.

[0075] Optionally, additional methods may be used to facilitate introducing the distal tip 35 and balloon 50 through

the terminal valve 95a, e.g., instead of simply pushing the distal tip 35 through the valve 95a. For example, the terminal valve 95a may be monitored using external imaging or otherwise monitored to coordinate timing of movement of the terminal valve 95a with physiological events, e.g., heart rate, and the like, until the terminal valve 95a naturally opens, whereupon the distal tip 35 may be advanced through the open valve 95a into the thoracic duct 94. Alternatively, the user may trigger opening of the terminal valve 95a, e.g., by increasing lymph within the patient’s body, for example, by squeezing tissue in the arm or leg.

[0076] In another alternative, a negative pressure may be created within the junction, e.g., by aspirating into the catheter 10 or otherwise, with the resulting vacuum causing the terminal valve 95a to open and allow the distal tip 35 to be advanced into the thoracic duct 94. In other alternatives, the user may simply periodically probe the terminal valve 95a by gently advancing the distal tip 35 against the valve 95a and/or by rotating the catheter 10 to screw the distal tip 35 through the valve 95a. Further alternatively, the balloon 50 (or other distal expandable member) may be at least partially expanded to assist in centering the distal tip 35 in or near the ostium in order to more easily cross the valve 95a.

[0077] In yet another alternative, a helical tip member (not shown) may be provided on the distal portion 30 that extends from the distal tip 35, which may be rotated to guide the distal tip 35 through the terminal valve 95a. In these alternatives, the distal portion 30 may pass through the terminal valve 95a until the balloon 50 is positioned between the terminal valve 95a and the next valve 95b within the thoracic duct 94. The balloon 50 may then be inflated to engage the wall of the thoracic duct 94 and substantially seal and/or isolate the thoracic duct 94 from the veins 92.

[0078] With the balloon 50 expanded to substantially isolate the thoracic duct 94, fluid may be aspirated into the lumen 26 of the catheter 10 and collected, e.g., as described elsewhere herein, fluid may be delivered into the thoracic duct 94, and/or other desired procedures may be performed via the thoracic duct 94.

[0079] In an alternative embodiment, shown in FIG. 4D, the catheter 10' may include a movable distal tip 35,' which may be directed axially closer to or away from the balloon 50.' For example, the balloon 50' may be attached to the distal end of an outer tubular member 30,' and an inner tubular member 37' may extend through the outer tubular member 30' and the balloon 50,' and terminate in the distal tip 35.' Thus, movement of the inner tubular member 37' relative to the outer tubular member 30' may move the distal tip 35' relative to the balloon 50.' In this alternative, the balloon 50' may serve to substantially center the distal tip 35' relative to the valve(s) 95 within the thoracic duct 94 (not shown in FIG. 4D), e.g., such that the distal tip 35' may be advanced or retracted as desired relative to the valve(s) 95 to facilitate access, removal of fluid, and/or performing other procedures within the thoracic duct 94.

[0080] Optionally, the suction pressure used to aspirate lymph within the thoracic duct 94 may be adjusted, e.g., to substantially match the individual patient’s maximum lymph flow. If the patient lymph flow changes over time, this method anticipates adjustment of pressure over time, both decreasing suction pressure over time, and increasing suction pressure over time, as desired.

[0081] In another option, fluids or other substances may be infused into the thoracic duct 94 or vein via the catheter 10, if

desired, e.g., in a substantially continuous or oscillatory manner. For example, one or more of the following may be infused: blood contaminated lymph, lymph with greater concentrations of desired substances, and the like, as described elsewhere herein.

[0082] In another embodiment (not shown), the catheter may include a distal end and a balloon sized to be introduced into the thoracic duct. For example, the distal end may be advanced beyond a valve in the thoracic duct such that the balloon may be inflated beyond the valve. In addition or alternatively, the catheter may include one or more other features for securing and/or sealing distal to a valve, including one or more compliant rings, radial filaments/brushes, and/or other passive fixation devices (not shown) that may at least partially resist retraction or avoid spontaneous dislodgement of the catheter during use. In addition or alternatively, active fixation, such as suction, may be used to substantially fix the distal end of the catheter at a desired location, e.g., within the thoracic duct.

[0083] Turning to FIGS. 7A and 7B, another embodiment of a catheter **110** is shown that includes a pair of balloons **150** spaced apart axially from one another on a distal portion **130** of the catheter **130**. The balloons **150** may communicate with a single inflation lumen (not shown) such that the balloons **150** may be inflated and/or collapsed substantially simultaneously. Alternatively, the balloons **150** may communicate with separate inflation lumens (also not shown) such that the balloons **150** may be inflated and/or collapsed independently of one another. The catheter **110** may have a size, length, and/or shape configured to be introduced and/or manipulated using a handle or hub on a proximal end (not shown) of the catheter **110**, similar to other embodiments herein.

[0084] As shown in FIGS. 7A and 7B, a distal tip **135** of the catheter **110** may be introduced into the thoracic duct **94** until the balloons **150** pass beyond the terminal valve **95a**. Optionally, as shown in FIG. 7A, the balloons **150** may be spaced apart sufficiently from one another such that the balloons may be provided on either side of the next valve **95b** within the thoracic duct **94**, i.e., with a proximal balloon **150a** between a first and second valve **95a**, **95b**, and a distal balloon **150b** between the second and third valves **95b**, **95c**. Such an arrangement of balloons **150** may provide enhanced stability for the distal portion **130** and/or improved sealing of the thoracic duct **94**.

[0085] Optionally, the balloons **150** may be configured such that the balloons **150** may be positioned with a valve **95b** located between the balloons **150**. When the balloons **150** are inflated, they may squeeze or otherwise engage the valve **95b** to enhance sealing of the thoracic duct **94** using the valve **95b** in addition to the balloons **150** engaging the wall of the thoracic duct **94**. In another option, shown in FIG. 7B, the balloons **150** may be positioned on either side of the terminal valve **95a** such that the distal balloon **150b** is positioned between the first and second valves **95a**, **95b**, and the proximal balloon **150a** engages the ostium of the thoracic duct **94** outside the terminal valve **95a**, which may reduce the risk of blood entering the thoracic duct **94** from the veins **92**. Further alternatively, the balloons **150** may be slidably disposed relative to one another (not shown) such that they may be brought together or moved apart, e.g., to capture and/or release a valve positioned between them. Further alternatively, one or more balloons may include different surface properties, e.g. a lubricious distal surface (e.g., using a hydrophilic coating, lubrication, surface features, and the like), e.g., to facilitate valve

crossing and a less lubricious proximal surface to, e.g. to decrease the chance of inadvertent removal.

[0086] Turning to FIG. 8, still another embodiment of a catheter **210** is shown that includes a plurality of tines **254** on the distal portion **230** adjacent the balloon **250**. The tines **254** may be biased to expand outwardly, but may be compressible inwardly, e.g., using an external sleeve or other constraint (not shown), which may be removed, e.g., after positioning the balloon **250** at a desired position within a thoracic duct (also not shown). When the tines **254** are deployed, they may engage the wall of the thoracic duct to anchor the distal portion **230** to prevent movement even if the balloon **250** is collapsed. The tines **254** may include substantially blunt free ends to engage the thoracic duct without penetrating or damaging the wall, or may include sharpened tips and/or barbs (not shown), which may be substantially permanently or indefinitely engage the wall of the thoracic duct. Thus, this embodiment may be used to secure the catheter **210** substantially indefinitely, e.g., for a long-term implant that is used to intermittently isolate the thoracic duct by expanding the balloon **250**, e.g., to collect lymph. When not needed, the balloon **250** may be collapsed allowing normal function of the thoracic duct while the tines **254** prevent migration of the catheter **210** from the thoracic duct. If desired, the catheter **210** may be removed, e.g., by directing a sheath or other tubular member (not shown) into the thoracic duct to recapture and/or otherwise collapse the tines **254**.

[0087] Alternatively, other features may be provided on the catheter, e.g., in addition to or instead of the tines **254** to maintain the distal end of the catheter **210** (or any of the embodiments herein) in a desired position, e.g., within the thoracic duct. Exemplary features may include providing silicone or other anti-slip materials on the distal end, a Nitinol or other expandable anchoring structure, an anchor ring, and the like (not shown).

[0088] Turning to FIGS. 9A-9C, another embodiment of a catheter **310** is shown that includes an expandable frame **350** on a distal portion **330** including a set of wires or struts that may be manipulated from a proximal end (not shown) of the catheter **310**. For example, an actuator on the proximal end (not shown) may be activated to direct the frame from a collapsed configuration (shown in FIG. 9A) to an enlarged configuration (shown in FIG. 9B). The size of the frame **350** may be sufficient to engage a wall of a thoracic duct when the distal portion **330** is introduced into the thoracic duct, as described elsewhere herein.

[0089] As shown in FIG. 9C, the frame **350** may carry a nonporous membrane that may be directed across the thoracic duct when the frame **350** is expanded to substantially seal the thoracic duct. Thus, the frame **350** may operate similar to the balloons described elsewhere herein, except that the frame **350** is mechanically actuated rather using fluid to inflate and collapse the balloons.

[0090] Turning to FIG. 10, yet another embodiment of a catheter **410** is shown that includes an expandable frame **450** on a distal portion **430** including a set of wires or struts **452** carrying a non-porous membrane **454**. The frame **450** may be biased to an enlarged configuration, e.g., in which the struts are shaped to engage and/or enter the ostium of a thoracic duct, yet may be resiliently compressed into a delivery configuration, e.g., when placed within a delivery catheter **460**. Alternatively, the frame **450** may be actuated from a proximal end (not shown) of the catheter **410**, e.g., similar to the previous embodiments. The size of the frame **450** may be suffi-

cient to engage the ostium adjacent the thoracic duct, or may be sized for introduction into the thoracic duct such that the membrane 454 sealingly engages the wall of the thoracic duct, e.g., when the distal portion 430 is introduced into the thoracic duct on either side of one or more valves, similar to other embodiments herein.

[0091] Turning to FIG. 5, the apparatus 8 shown in FIG. 1, or any of the other embodiments herein, may be part of a system 6 including one or more external components for performing a medical procedure, e.g., which may involve removing lymphatic fluid from the patient's body 90 via the thoracic duct 94, introducing agents or devices (not shown) into the thoracic duct 94, and/or infusing the removed lymphatic fluid, components thereof, and/or other agents into other locations within the patient's body 90. For example, one or more external devices may be provided that are coupled to the proximal end 22 of the catheter 10, e.g., for detecting, separating, collecting, and/or infusing lymphatic fluid and/or other fluids, as described in U.S. Publication No. 2011/0276023, the entire disclosure of which is expressly incorporated by reference herein. The external components may be provided integrated into a single device or may be provided as separate discrete components that are coupled to one another (e.g., along a fluid path, electrically, and/or otherwise).

[0092] In the example shown schematically in FIG. 5, the external components include a detector or analyzer 60, a controller 62, a separator 64, a waste container 66, a storage container 68, and an infusion device 70. One or more of the components may include a pump or source of vacuum or pressure, e.g., for removing fluid from the patient's body and/or delivering fluid into the patient's body 90 via the catheter 10, or infusing fluids via the infusion device 70, as described further below. In alternative embodiments, one or more of the components may be omitted. For example, the catheter 10 may simply be coupled directly to the storage container 68, e.g., with or without a source of vacuum to facilitate collection of lymphatic fluid.

[0093] The detector 60 may be coupled to the proximal end 22 of the catheter 10, e.g., to the port 23a on the handle 23, for receiving fluids that are drawn through the lumen 26 of the catheter 10 from the inlet port 36 in the distal tip 35 (not shown in FIG. 5, see, e.g., FIGS. 2A, 2B). The detector 60 may include one or more sensors (not shown), e.g., for distinguishing between lymphatic fluid and blood. In addition or alternatively, one or more sensors may be provided on the distal end 34 of the catheter 10, e.g., to detect when the thoracic duct is accessed and/or sealed from the venous system. In exemplary embodiments, the sensor(s) may include one or more optical sensors (e.g., for detecting the presence of red blood cells by light transmission or reflection characteristics), chemical sensors (e.g., for detecting one or more of pH, oxygen concentration, lactate, leukocyte esterase, and the like), sensors for measuring hematocrit, electrical sensors (e.g., for measuring impedance), temperature sensors, mechanical sensors (e.g., for detecting pressure waves, which may differ between the venous system and the thoracic duct; for flow detection, e.g., by Doppler ultrasound), filter devices sized to constituents of whole blood, and the like. In addition or alternatively, a sensor may be provided that is adapted to detect the presence of an exogenous marker introduced into the lymphatic system, such as a dye (e.g., methylene blue), an ingested marker, a fluorescent marker, and the like.

[0094] For example, a pump or other source of vacuum or pressure (not shown) within or coupled to the detector 60 may

be selectively activated, e.g., by the controller 62 (or alternatively manually by a user, if desired), to remove fluid from the patient's body via the catheter 10 through the detector 60 to the separator 64. The controller 62 may automatically analyze sensor data from the sensors to identify whether the fluid is lymphatic fluid, blood, or other fluid.

[0095] For example, if the controller 62 determines that the fluid includes blood, the controller 62 may direct the fluid to the waste container 66, e.g., through the separator 64 or directly. In addition or alternatively, if the controller 62 detects the presence of a significant amount of blood in the fluid (based on data from the detector 60 or otherwise) or detects a loss of seal (e.g., due a sudden pressure change in the fluid being removed via the catheter 10), the controller 62 may shut down the pump, close a shut-off valve (not shown) in the detector 60, or otherwise stop flow of fluid from the catheter 10 into the detector 60 and/or the rest of the system 6. This safety mechanism may be active, i.e., shut down automatically, or passive, i.e., merely warn the user.

[0096] In an exemplary embodiment, the separator 64 may include a valve (not shown) including an inlet 64a that communicates with the detector 60, a first outlet 64b communicating with the storage container 68, and a second outlet 64c communicating with the waste container 66. The valve may be selectively operable between the first and second outlets 64b, 64c by the controller 62, e.g., to direct undesired fluid, e.g., blood, to the waste container 66, and desired fluid, e.g., lymphatic fluid or components thereof, to the storage container 68. Alternatively, or in addition, the separator 64 may include one or more devices for separating various components of lymphatic fluid, including various types of cells, proteins, electrolytes, water, and/or other constituent parts of lymphatic fluid. For example, water may be substantially separated from other components in order to selectively remove excess water from a patient. As another example, pathologic cells may be selectively separated from other constituents in order to remove pathologic cells from a patient.

[0097] In an alternative embodiment, a filter (not shown) may be provided within the detector 60 or separator 64, which may clog in the presence of a predetermined number or concentration of cells, e.g., red blood cells, to prevent the fluid from being delivered into the storage container 68. In a further alternative, coagulation/clotting may be used to prevent flow in the presence of whole blood and its constituents (for example, platelets). For example, a passage through the detector 60 or other external component may be sized to clot spontaneously, a filter may be used where clotting decreases flow, and/or pro-coagulant materials may be used to augment or accelerate a clotting response. In such alternatives, the component of the system 6 designed to prevent flow may be cleanable and/or replaceable, e.g., to allow to resumption of flow after isolation of the thoracic duct 94 is reestablished.

[0098] If the controller 62 confirms that the fluid is lymphatic fluid, the controller 62 may activate the separator 64 to direct the lymphatic fluid or components of the lymphatic fluid into the storage container 68. For example, if the entire lymphatic fluid is to be collected, the separator 64 may simply divert the fluid into the storage container 68. Alternatively, it may be desirable to separate certain constituents of the removed fluid, e.g., lymphatic fluid, particular cells, proteins, and the like. For example, the separator 64 may include one or more of a mechanical filtration system, an osmotic gradient system, a concentration gradient system, a centrifuge, and the like to separate the desired components from the rest of the

fluid. Once separated, the desired components may be delivered to the storage container 68, while the rest of the fluid is delivered to the waste container 66.

[0099] Optionally, the controller 62 or other components of the system 6 may monitor the flow to keep track of the amount of fluid extracted and/or to stop after a predetermined amount of fluid is extracted. In addition or alternatively, the controller 62 may operate the pump, vacuum source, valve, and/or other components of the system 6 periodically or otherwise intermittently, e.g., to allow reaccumulation of fluid within the lymphatic vessels.

[0100] In certain cases, it may be desirable to re-infuse all or a portion of the lymphatic fluid removed, for example, all cells and/or proteins (e.g., discard fluid and retain the useful constituents of lymph), only a certain portion of removed cells and/or proteins, (e.g., discard harmful constituents and retain useful constituent), and/or other constituents of the removed lymphatic fluid. One approach may be simply to retain an initial volume of removed fluid that may have a higher concentration of cells, proteins, and the like compared to the subsequent volume removed. For example, there may be a relatively small initial volume of lymphatic fluid in the vessels that, upon sustained drainage, may be repleted with interstitial fluid having relatively few cells. Alternatively, filtration, separation, or other methods may be used to create a desirable portion for reinfusion.

[0101] For example, as shown in FIG. 5, an infusion catheter 70 may be provided that includes a proximal end 70a coupled to the storage container 68, and a distal end 70b sized for delivering the stored fluid into the patient's body 90. Alternatively, the lymphatic fluid removed from the patient's body may be reinfused, e.g., after separation, treatment, and the like, back into the thoracic duct 94 using the catheter 10 already positioned in the thoracic duct 94. In addition or alternatively, the catheter 10 may be used to infuse other fluid directly into the thoracic duct 94, e.g., as described further elsewhere herein.

[0102] For example, the catheter 10 may include a single infusion lumen, e.g., for removing lymphatic fluid and returning any desired fluids back into the patient's body. Alternatively, the catheter 10 may include multiple lumens (not shown), e.g., an aspiration lumen for removing lymphatic fluid and an infusion lumen for delivering fluids (e.g., to the thoracic duct and/or adjacent vein), such as treated lymphatic fluid and/or other diagnostic or therapeutic compounds. Such lumens may terminate at the distal portion of the catheter 30 and/or more proximally. For example, the aspiration lumen may include an inlet distally beyond the balloon, e.g., for aspirating fluid from the isolated thoracic duct, while the infusion lumen may include an outlet proximal to the balloon, e.g., to provide a fluid channel into the venous system adjacent to the thoracic duct. In addition or alternatively, the catheter 10 may include a working lumen sized for receiving auxiliary devices therethrough (not shown), e.g., larger than the infusion lumen(s) for receiving one or more guidewires, auxiliary catheters, and the like (not shown). If the catheter 10 includes one or more balloons, e.g., balloon 50 shown in FIG. 1, the catheter 10 may also include one or more inflation lumens (not shown), e.g., adjacent the aspiration, infusion, and/or working lumen(s), for inflating and/or collapsing the balloon(s) together or independently of one another, as described elsewhere herein.

[0103] The catheters, systems, and methods described herein may be used to perform a variety of procedures within

the patient's body, e.g., to diagnose and/or treat a variety of conditions. For example, since lymphatic fluid drains interstitial fluid from the patient's body, removal of lymphatic fluid may facilitate reduction of interstitial fluid volume without significant alterations in circulating blood volume of the patient. In addition, lymphatic fluid contains a much higher concentration of various components (e.g., immune cells, proteins, lipids, externalized RNA (e.g., exosomes), and the like) than are contained in circulating blood. The relative ease of access to these components at relatively higher concentrations directly in lymphatic fluid may be useful in diagnosing and treating certain medical conditions. For example, cell populations, their level of maturity and/or activation, their cell surface markers or other distinguishing features in the lymph may be assayed to diagnose various disease or normal physiologic states, including those discussed below.

[0104] Optionally, lymphatic parameters may be used in conjunction with other parameters of the patient to facilitate diagnosis and/or treatment. For example, lymphatic parameters may be compared to other patient parameters, such as blood pressure, peripheral blood contents, oxygen saturation, and the like, to extract a diagnosis of the patient's condition. In addition or alternatively, one or more parameters of the lymphatic fluid may be compared with similar parameters of whole blood elsewhere in the patient's body, e.g., to facilitate diagnosis of one or more conditions. For example, an analyzer or other device coupled to the catheter may determine a ratio of a desired parameter of the patient's whole blood with the patient's lymphatic fluid, and monitor or assess the ratio over time for diagnostic purposes. In another embodiment, lymphatic parameters may assist with digestive monitoring of a patient, e.g., in conjunction with monitoring the patient's chylomicron transit, flow rate, and/or count.

[0105] In an exemplary embodiment, a patient suffering from sepsis may be diagnosed and/or treated using any of the catheters and/or methods described herein. Sepsis is inflammation throughout a patient's body, e.g., due to severe infection. To treat this inflammation, lymphatic fluid may be removed from the patient's body via a catheter accessing the thoracic duct, treated, and then at least partially returned to the patient's body, e.g., via the catheter 10 back into the thoracic duct or elsewhere in the patient's vasculature.

[0106] For example, leukofiltration of the removed lymphatic fluid may be performed, e.g., to reduce or entirely remove leukocytes (white blood cells) from the fluid before returning some or all of the fluid to the patient's body, e.g., to decrease immune response by the patient's body. Alternatively, one or more materials may be filtered from the lymphatic fluid, such as antibodies, interleukins (IL, e.g. IL-1, IL-2, etc.), and mediators and/or other factors before returning the lymphatic fluid to the patient's body, e.g., to decrease t-cell activation or other inflammatory response by the patient's body. In another embodiment, dialysis may be performed on the removed lymphatic fluid to remove at least one of toxins and non-cellular mediators before returning the some or all of the lymphatic fluid to the patient's body. In yet another embodiment, components of the lymphatic fluid, such as immune cells/white blood cells (WBCs), antibodies, IL, and/or other mediators/factors may be detected, analyzed, and/or quantified to diagnose or assess the presence and/or severity of sepsis, and or other inflammatory/immunologic conditions. In addition or alternatively, the quantity, composition, activity, and/or characteristics of immune cells/WBCs,

antibodies, IL and/or other mediators/factors may be altered to diagnose or treat sepsis, and or other inflammatory/immunologic conditions.

[0107] In another embodiment, the catheters, systems, and methods herein may be used for treating conditions related to cirrhosis, e.g., due to severe liver disease, and/or other derangements of oncotic and/or hydrostatic pressure. For example, esophageal varicies (extremely dilated sub-mucosal veins in the esophagus) may be treated by removing lymphatic fluid, which may decrease portal pressure within the portal vein (into which some blood from the esophageal veins drains) and thereby reduce dilation of the esophageal veins. In addition or alternatively, removal of lymphatic fluid may reduce ascites, i.e., peritoneal fluid that may accumulate in the peritoneal cavity, may reduce acute or chronically elevated portal pressure, and/or may otherwise facilitate slowing or otherwise treating hepatorenal syndrome.

[0108] In yet another embodiment, the catheters, systems, and methods herein may be used to monitor, diagnose, and/or treat immune disorders. For example, the removed lymphatic fluid may be analyzed, e.g., to sample and/or compare one or more parameters of the fluid. In one embodiment, a composite assay may be generated of the fluid to provide a snapshot of the entire immune system of the patient, e.g., to monitor immune disorders or the general health of the patient. In another embodiment, cell populations, their level of maturity and/or activation, their cell surface markers or other distinguishing features, e.g. t-cell population and/or status, in the fluid may be assayed to monitor changes indicating function and/or rejection of an implant. In yet another embodiment, the fluid may be analyzed to monitor autoimmune conditions, e.g., to identify when treatment and/or surgery is needed based on the number antagonistic t-cells in the fluid. In addition or alternatively, for immune disorders, one or more therapeutic compounds, e.g., antigens, vaccines, and/or other immune-stimulating compounds may be introduced directly into the lymphatic system, e.g., via the catheter used to remove the lymphatic fluid, or to removed fluid to be subsequently re-infused into the body, which may generate a more rapid and/or robust immune response than introduction into other locations within the patient's body.

[0109] In still another embodiment, the catheters, systems, and methods herein may be used to diagnose or treat HIV and/or other viral infections. For example, the removed fluid may be analyzed to detect, quantify, and/or manipulate latently infected cell populations of the patient. In addition or alternatively, latently infected cell populations may be filtered, destroyed, and/or otherwise eliminated or passivated to treat the infection. Optionally, one or more components of the removed lymphatic fluid may be altered and/or returned to the patient's body, e.g., the patient's own t-cells or other cells and/or proteins, alone or along with other fluids, e.g., osmotically active fluid, osmotically neutral fluid, drugs to activate the virus, and the like, e.g., to push the patient towards a virus-free equilibrium and/or restore natural immune function after suppression. For example, lymphocytes may be removed via lymph, treated (e.g., by gene therapy or other methods) to cause them to be at least partially resistant to infection by or effects of the HIV virus, and reintroduced into the body.

[0110] In another embodiment, the catheters, systems, and methods herein may be used to monitor and/or treat cancer patients. For example, one or more parameters of lymphatic fluid removed from the thoracic duct may be analyzed to

monitor the cancer status, progression, prognosis, and/or metastatic burden of a patient. For example, cancer status may be monitored based on detecting and/or quantifying circulating t-cell phenotype by surface markers, cancer-related antigens, cancer-related mediators, externalized RNA (e.g., exosomes such as those from dying cancer cells or damaged cells proximate to a tumor) and/or cancer cells. For example, diagnosis of remission and/or recurrence may be based on the type and/or quantity of mediators, t-cells, and/or other cell or markers, as enumerated above, in the removed fluid.

[0111] In still another embodiment, the catheters, systems, and methods herein may be used for treating lymphatic disorders of a patient, such as lymphedema (localized fluid retention and/or tissue swelling within the thoracic duct or elsewhere in the lymphatic system). For example, a distal end of a catheter may be introduced into a thoracic duct and an expandable member on the distal end may be expanded to substantially seal and/or isolate the thoracic duct from the patient's venous system, as described elsewhere herein. One or more medications and/or biologics may be infused into the thoracic duct via the catheter, e.g., to stimulate lymphatic growth and/or otherwise treat lymphedema. In this embodiment, lymphatic fluid may be removed from the thoracic duct through the catheter, if desired, e.g., to analyze the fluid before introducing the medication(s) and/or to mix the medication(s) with the fluid and/or components of the fluids, similar to other embodiments herein.

[0112] In addition or alternatively, the catheter may be used to treat one or more lymphatic stenoses, e.g., using one or more auxiliary devices introduced through a working lumen of the catheter into the thoracic duct and/or elsewhere within the lymphatic system via the thoracic duct. For example, a balloon catheter or other angioplasty device may be introduced through the primary catheter and positioned within a stenotic region of the thoracic duct, and then expanded to dilate and/or otherwise treat the region. In addition or alternatively, a stent or other tubular device may be implanted at the region, e.g., on an angioplasty catheter or other delivery device introduced through a working lumen of the primary catheter to dilate a lymphatic vessel.

[0113] In accordance with another embodiment, the catheters, systems, and methods herein may be used to diagnose and/or treat chylothorax, i.e., leaks within the thoracic duct or elsewhere within the lymphatic system. For example, with the thoracic duct isolated using a balloon catheter introduced from a percutaneous entry site (e.g., similar to other embodiments shown elsewhere herein), fluid may be infused into the thoracic duct, i.e., retrograde into the thoracic duct, to facilitate diagnosis of chylothorax. For example, fluid may be infused into the thoracic duct simply to determine whether the fluid remains within the thoracic duct, e.g., by measuring a pressure within the thoracic duct via the catheter. If the pressure and/or volume of fluid remains substantially constant, the patient is unlikely to have chylothorax. In addition or alternatively, the fluid may include contrast, and external imaging, e.g., fluoroscopy, ultrasound, and the like, may be used to diagnose chylothorax and/or to identify the location of any sites of breach within the lymphatic system, e.g., based on the contrast leaking from the lymphatic system at one or more breaches.

[0114] Optionally, the catheter may be used to treat the site of any breaches, e.g., by delivering a guidewire or other rail (not shown) through the working lumen of the catheter to the

target site, e.g., using further contrast and/or imaging. A treatment element (not shown) may then be introduced over the guidewire or otherwise through the catheter to the target site to substantially seal and/or otherwise repair the site. For example, using similar methods to other embodiments herein, a stent, covered stent, stent-graft, coil, or other tubular prosthesis (not shown) may be introduced through the working lumen of the catheter, e.g., using a delivery catheter or other device (also not shown). Once positioned across the target site, the prosthesis may be expanded or otherwise deployed to cover and/or substantially seal any leaks at the target site. In addition or alternatively, other materials may be delivered to the target site, e.g., via the same or different delivery device than the prosthesis. For example, thrombin, foam, platelet-rich plasma (PRP), blood components, and/or a blood patch may be applied to the wall of a lymphatic vessel identified as having a breach or other leak, e.g., instead of or in conjunction with a prosthesis. Once any sites are repaired, further contrast or other fluid may be introduced to confirm that no further leaks exist, e.g., using additional imaging, whereupon the catheter may be removed from the patient's body. In an alternative embodiment, similar devices and methods may be used to manage a dissection within the thoracic duct or elsewhere in the lymphatic system.

[0115] In accordance with still another embodiment, the catheters, systems, and methods herein may be used for acute to medium-term volume management of a patient. For example, for a patient being treated in an inpatient setting, a balloon catheter may be introduced from a percutaneous entry site into the patient's venous system to isolate the thoracic duct, e.g., similar to other embodiments shown elsewhere herein. When desired, a medical professional may substantially continuously, periodically, or intermittently drain lymphatic fluid from the patient's thoracic duct based on desired treatment protocols for the patient. For example, lymphatic fluid removal may be titrated, e.g., to a desired level or amount, such as to maintain a desired flow rate through the thoracic duct, maintain a desired pressure within the thoracic duct, remove a desired volume of lymphatic fluid, achieve a desired color of the lymphatic fluid, and/or other lymph parameter. In addition or alternatively, the titration may be based on one or more parameters of the patient, e.g., the patient's body weight, central venous pressure (CVP), oxygen saturation, blood pressure, urine output, dyspnea, and/or other external, clinical, and/or systemic parameter.

[0116] In addition or alternatively, the catheters, systems, and methods may be used for a patient during a surgical procedure, e.g., to measure one or more parameters of the patient's lymphatic system and/or manage volume status intra/peri/post-operatively. For example, pressure, flow rate, and/or other lymphatic parameters may be measured within the thoracic duct to assess and/or alter ventilation or fluid status of the patient during the procedure. The catheter may be used to infuse crystalloid, colloid, and/or other fluid into the thoracic duct and/or remove lymphatic fluid from the thoracic duct to achieve or maintain the desired parameter(s) and/or physiologic state. In an exemplary embodiment, such fluid management may be used during a cardiac bypass procedure, e.g., to selectively remove lymphatic fluid to provide tight fluid management. Alternatively, the catheter may be used to manage volume of an anuric/oliguric patient intra/peri/post-operatively.

[0117] In accordance with another embodiment, the catheters, systems, and methods herein may be used for other

diagnostic and/or therapeutic procedures. For example, in one embodiment, a distal end of a catheter introduced into a patient's venous system from a percutaneous access site may be positioned within the patient's thoracic duct to isolate the thoracic duct. Lymphatic fluid may be removed from the thoracic duct, and a subset of immunologic cells may be isolated, e.g., T-cells, dendritic cells, etc. The isolated cells may be stimulated, genetically altered, and/or otherwise manipulated, e.g., to enable the isolated cells to target infectious, cancerous, and/or other deleterious cells present in the patient, and the isolated cells may be reintroduced into the patient's body, e.g. via the patient's peripheral circulation, via the patient's lymphatic system, and/or by localized introduction. Alternatively, the isolated cells may be stimulated, genetically altered, and/or otherwise manipulated, e.g., to impart to the isolated cells resistance or immunity to infections or other causes of cellular damage (e.g., radiation, chemotherapy, and the like).

[0118] Optionally, the isolated cells may be used to generate a clonal population and/or differentiated to generate a derivative cell population. In addition or alternatively, the isolated cells may undergo extracorporeal sensitization, e.g., to stimulate recognition of deleterious cells, proteins, antigens, surface markers, and the like, which may be present within the patient's body and/or achieve resistance or immunity as discussed above. In addition or alternatively, the concentration of cells of interest in the lymphatic fluid may be increased a priori, e.g., by interleukin, filgrastim, pegfilgrastim, and the like.

[0119] In another embodiment, a distal end of a catheter introduced into a patient's venous system from a percutaneous access site may be positioned within the patient's thoracic duct to isolate the thoracic duct. Lymphatic fluid may be removed from the thoracic duct, and one or more cell populations, e.g. actively infected and/or latently infected cells, may be identified from the fluid. Some or all of the identified cell populations may be separated from the fluid or otherwise removed and/or destroyed, and some or all of the remaining fluid may be reintroduced into the patient's body, e.g., via the patient's peripheral circulation, via the patient's lymphatic system. In addition or alternatively, the lymphatic fluid may be filtered, irradiated, and/or otherwise treated, e.g., to remove, eliminate, deactivate, and/or destroy free virus present therein. In addition or alternatively, the concentration of cells of interest in the lymphatic fluid may be increased a priori, e.g. by interleukin, filgrastim, pegfilgrastim, and the like.

[0120] In still another embodiment, the catheters and systems herein may be used in a method for treating a viral infection, e.g., HIV, that includes simultaneously subjecting the patient to pharmacologic anti-viral therapy, and direct manipulation of lymphatic fluid, e.g., to reduce, disable, and/or eliminate one or more of the following: actively infected cells, latently infected cells, and/or free virus.

[0121] In yet another embodiment, the catheters and systems herein may be used in a method for more readily accessing cells, proteins, factors, and/or other components present in whole blood. For example, a catheter may be introduced from a percutaneous access site into the patient's venous system and manipulated to isolate the patient's thoracic duct and extract lymphatic fluid, similar to other embodiments herein. Certain cells, proteins, factors, and/or other components of the fluid may be present at a higher concentration than in the patient's whole blood, and such cells, proteins,

factors, and/or other components may be removed from the lymphatic fluid, manipulated, and/or reintroduced into the patient's body, e.g., into the thoracic duct, another location within the patient's vasculature, and the like.

[0122] In still another embodiment, the catheters and systems herein may be used in a method for achieving a more rapid and/or robust immune response by introducing an antigen, vaccine, and/or other immuno-stimulating agent directly into the lymphatic system via a catheter introduced from a percutaneous access site to isolate the patient's thoracic duct, similar to other embodiments herein.

[0123] In yet another embodiment, a diagnostic assay may be obtained, wherein the concentration of one or more components of whole blood and lymph are sampled independently from one another, e.g. in order to generate a ratio of the concentration, activity level, and/or other parameter(s) of the sampled components in whole blood and lymph.

[0124] In still another embodiment, the catheters and systems herein may be used in a method for removing toxins from a patient's body without substantially affecting the circulating blood volume. For example, a catheter may be introduced from a percutaneous access site into the patient's venous system and manipulated to isolate the patient's thoracic duct. Lymphatic fluid may be removed from the patient's body, filtered, e.g., dialyzing the fluid, and the filtered lymphatic fluid may be reintroduced into the peripheral circulation.

[0125] In another embodiment, the catheters and systems herein may be used for the implantation of one or more ports, sensors, and/or other devices within a patient's body. For example, a catheter may be introduced from a percutaneous access site into the patient's vascular system and one or more sub-acute, chronic, and/or permanent ports, catheters, sensors, and/or other devices (not shown) may be implanted within the patient's body via the vascular system. The device(s) may provide access to the patient's circulating blood volume without thrombogenic potential. In addition or alternatively, the device(s) may be used to infuse and/or monitor one or more drugs or other compounds, and/or for pacing. Such devices may provide diminished thrombogenic potential, diminished cellular overgrowth, and the like.

[0126] It is known that lymph does not contain platelets and is not prone to clotting unlike whole blood. Therefore, implanting a foreign object or device in the lymphatic system, e.g., near the outlet of the thoracic duct, may permit monitoring and access to the circulatory system without the risk of thrombus formation as would be expected if the same object or device were placed directly in circulating blood. The implanted device may be used to monitor pressure, flow, and/or composition of the circulating blood. The implanted device may also function as an access port or pacemaker for stimulating cardiovascular or central or peripheral nervous system targets.

[0127] In addition, the systems and methods may be used for periodic sampling of TD for trending of contents over time. For example, any of the methods discussed above may be performed periodically, e.g., sampling lymph at desired intervals in order to trend its cellular composition and/or trend any of the other lymph related parameters discussed above.

[0128] In addition to the trans-venous approaches described elsewhere herein, it may also be possible to directly cannulate a lymphatic vessel and/or associated lymph node in order to access the lymphatic system using any of the systems and methods herein. In addition or alternatively, a catheter

similar to those described herein may be implanted permanently or indefinitely entirely within a patient's body, and other components for activating and/or using the catheter, e.g., to isolate and/or access the thoracic duct, aspirate and/or analyze lymphatic fluid, and/or infuse components of lymphatic fluid and/or other agents into a patient's body, for example, to diagnose, monitor, and/or treat any of the conditions described elsewhere herein. In this embodiment, a relatively large handle may be omitted on the proximal end of the catheter, and a hub or other low-profile component(s) may be provided on the proximal end to couple other implanted devices to the catheter. In addition, the catheter may be relatively small and/or flexible, e.g., substantially floppy along its entire length, compared to a catheter that is introduced temporarily via a percutaneous entry site.

[0129] While the invention is susceptible to various modifications, and alternative forms, specific examples thereof have been shown in the drawings and are herein described in detail. It should be understood, however, that the invention is not to be limited to the particular forms or methods disclosed, but to the contrary, the invention is to cover all modifications, equivalents and alternatives falling within the scope of the appended claims.

We claim:

1. A system for treating a patient via a thoracic duct of the patient's body, comprising:

a tubular member comprising a proximal end, a distal end sized for introduction into the patient's body into a thoracic duct, a lumen extending between the proximal and distal ends for removing fluid from a thoracic duct, and an expandable member on the distal end;

an ex-vivo treatment device for treating the removed lymphatic fluid removed from the thoracic duct; and

an infusion device for reintroducing the treated lymphatic fluid back into the patient's body.

2. The system of claim 1, wherein the ex-vivo treatment device is configured for one or more of:

a) performing leukofiltration of the removed lymphatic fluid before returning the lymphatic fluid to the patient's body to decrease immune response by the patient's body;

b) filtering at least one of antibodies, interleukin, and non-cellular mediators before returning the lymphatic fluid to the patient's body to decrease t-cell activation by the patient's body; or

c) performing dialysis on the removed lymphatic fluid to remove at least one of toxins and non-cellular mediators before returning the lymphatic fluid to the patient's body.

3. A method for treating a patient via a thoracic duct of the patient's body, comprising:

providing a tubular member comprising a proximal end, a distal end sized for introduction into the patient's body, and an expandable member on the distal end;

introducing the distal end of the tubular member into the patient's vasculature via a percutaneous access site with the expandable member in a contracted condition;

advancing the tubular member until the distal end is disposed within a junction of the patient's left internal jugular vein and left subclavian vein;

manipulating the tubular member to direct the distal end into the thoracic duct;

expanding an expandable member on the distal portion adjacent the distal tip to substantially isolate the thoracic duct from the left internal jugular vein and left subclavian vein;

removing lymphatic fluid from the thoracic duct through the tubular member to a location exterior to the patient's body;

treating the removed lymphatic fluid; and

returning at least a portion of the lymphatic fluid back into the patient's body.

4. The method of claim 3, wherein the at least a portion of the lymphatic fluid is returned into the thoracic duct through the tubular member.

5. The method of claim 3, wherein the at least a portion of the lymphatic fluid is returned to treat sepsis within the patient's body, and wherein treating the removed lymphatic fluid comprises one of:

- performing leukofiltration of the removed lymphatic fluid before returning the lymphatic fluid to the patient's body to decrease immune response by the patient's body;
- filtering at least one of antibodies, interleukin, and non-cellular mediators before returning the lymphatic fluid to the patient's body to decrease t-cell activation by the patient's body; or
- performing dialysis on the removed lymphatic fluid to remove at least one of toxins and non-cellular mediators before returning the lymphatic fluid to the patient's body.

6. The method of claim 3, wherein the at least a portion of the lymphatic fluid is returned to treat HIV or other viral infection within the patient's body, and wherein treating the removed lymphatic fluid comprises at least one of:

- separating t-cells from the fluid and wherein the at least a portion of the lymphatic fluid returned to the patient's body comprises the separated t-cells; and
- separating protein from the fluid and wherein the at least a portion of the lymphatic fluid returned to the patient's body comprises the separated protein.

7. The method of claim 3, wherein the at least a portion of the lymphatic fluid is returned to treat HIV or other viral infection within the patient's body, and wherein treating the removed lymphatic fluid comprises:

analyzing the removed lymphatic fluid to detect latently infected cell populations of the patient.

8. The method of claim 7, wherein the removed lymphatic fluid is returned to the patient's body to push the patient towards a virus-free equilibrium or restore natural immune function after suppression.

9. The method of claim 3, wherein the at least a portion of the lymphatic fluid is returned to treat HIV or other viral infection within the patient's body, wherein treating the removed lymphatic fluid to the patient's body comprises adding one or more compounds to the removed lymphatic fluid returning at least a portion of the lymphatic fluid back into the patient's body, and wherein returning the lymphatic fluid to the patient's body comprises infusing the removed lymphatic fluid with the one or more added compounds to push the patient towards a virus-free equilibrium or restore natural immune function after suppression.

10. The method of claim 9, wherein the one or more compounds comprise at least one of osmotically active fluid, osmotically neutral fluid, and one or more drugs to activate a virus causing the viral infection.

11. A method for treating a patient via a thoracic duct of the patient's body, comprising:

providing a tubular member comprising a proximal end, a distal end sized for introduction into the patient's body, and an expandable member on the distal end;

introducing the distal end of the tubular member into the patient's vasculature via a percutaneous access site with the expandable member in a contracted condition;

advancing the tubular member until the distal end is disposed within a junction of the patient's left internal jugular vein and left subclavian vein;

manipulating the tubular member to direct the distal end into the thoracic duct;

expanding an expandable member on the distal portion adjacent the distal tip to substantially isolate the thoracic duct from the left internal jugular vein and left subclavian vein; and

removing lymphatic fluid from the thoracic duct through the tubular member to a location exterior to the patient's body.

12. The method of claim 11, wherein the lymphatic fluid is removed to reduce volume of interstitial fluid within the patient's body.

13. The method of claim 12, wherein the lymphatic fluid is removed to reduce portal pressure within the patient's portal vein.

14. The method of claim 13, wherein the lymphatic fluid is removed to reduce portal pressure to treat esophageal varices.

15. The method of claim 13, wherein the lymphatic fluid is removed to reduce portal pressure to treat ascites.

16. The method of claim 11, wherein the lymphatic fluid is removed to manage hepatorenal syndrome.

17. The method of claim 11, further comprising:

treating the removed lymphatic fluid; and

returning at least a portion of the lymphatic fluid back into the patient's body.

18. The method of claim 11, wherein removing lymphatic fluid from the thoracic duct comprises periodically or intermittently drain lymphatic fluid from the thoracic duct to titrate the fluid to a desired level or amount.

19. The method of claim 18, wherein the fluid is titrated to achieve a desired lymph parameter selected from one or more of flow rate within the thoracic duct, pressure within the thoracic duct, volume removed, and color of fluid within the thoracic duct.

20. The method of claim 18, wherein the fluid is titrated to maintain a desired systemic parameter of the patient selected from one or more of the patient's body weight, central venous pressure (CVP), oxygen saturation, and dyspnea of the patient.

21. The method of claim 11, further comprising performing a surgical procedure on the patient, and wherein lymphatic fluid is removed from the thoracic duct for fluid management of the patient during the procedure.

22. The method of claim 21, wherein the surgical procedure includes a bypass procedure.

23. The method of claim 21, wherein the lymphatic fluid is removed for fluid management of the patient's anuria during the procedure.

24. The method of claim 21, further comprising measuring pressure within the thoracic duct using the tubular member to monitor at least one of ventilation of the patient and fluid

status of the patient, and wherein lymphatic fluid is removed from the thoracic duct based at least in part on the measured pressure.

25. A system for treating a patient via a thoracic duct of the patient's body, comprising:

- a tubular member comprising a proximal end, a distal end sized for introduction into the patient's body into a thoracic duct, a lumen extending between the proximal and distal ends for removing fluid from a thoracic duct, and an expandable member on the distal end; and
- an ex-vivo analyzer for analyzing the removed lymphatic fluid to monitor one or more parameters of the patient.

26. The system of claim **25**, wherein the ex-vivo analyzer is configured for one or more of:

- a) generating a composite assay of the removed lymphatic fluid to provide a snapshot of the immune system of the patient;
- b) comparing one or more parameters of the removed lymphatic fluid with other parameters of the patient to diagnose a medical condition;
- c) assaying at least one oft-cell population and status in the fluid to monitor changes indicating function or rejection of an implant within the patient's body;
- d) monitoring the one or more parameters to identify antagonistic t-cells to indicate that treatment of an autoimmune condition is needed;
- e) analyzing the removed lymphatic fluid to monitor a cancer status of the patient or to monitor one or more indicators of cancer metastasis of the patient;
- f) identifying at least one of type oft-cells and number oft-cells in the fluid to diagnose remission or recurrence of cancer within the patient's body;
- g) analyzing the removed lymphatic fluid to monitor the patient's cancer status based on detecting or quantifying circulating t-cell surface markers or substances found in circulating lymph that have been released by tumor cells.

27. A method for diagnosing, monitoring, or treating a patient via a thoracic duct of the patient's body, comprising:

- providing a tubular member comprising a proximal end, a distal end sized for introduction into the patient's body, and an expandable member on the distal end;
- introducing the distal end of the tubular member into the patient's vasculature via a percutaneous access site with the expandable member in a contracted condition;
- advancing the tubular member until the distal end is disposed within a junction of the patient's left internal jugular vein and left subclavian vein;
- manipulating the tubular member to direct the distal end into the thoracic duct;
- expanding an expandable member on the distal portion adjacent the distal tip to substantially isolate the thoracic duct from the left internal jugular vein and left subclavian vein;
- removing lymphatic fluid from the thoracic duct through the tubular member to a location exterior to the patient's body; and
- analyzing the removed lymphatic fluid to monitor one or more parameters of the patient.

28. The method of claim **27**, wherein analyzing the removed lymphatic fluid comprises generating a composite assay of the removed lymphatic fluid to provide a snapshot of the immune system of the patient.

29. The method of claim **27**, wherein analyzing the removed lymphatic fluid comprises comparing one or more parameters of the removed lymphatic fluid with other parameters of the patient to diagnose a medical condition.

30. The method of claim **27**, wherein analyzing the removed lymphatic fluid comprises assaying at least one oft-cell population and status in the fluid to monitor changes indicating function or rejection of an implant.

31. The method of claim **27**, wherein analyzing the removed lymphatic fluid comprises monitoring the one or more parameters to identify antagonistic t-cells to indicate that treatment of an autoimmune condition is needed.

32. The method of claim **27**, wherein the removed lymphatic fluid is analyzed to monitor a cancer status of the patient.

33. The method of claim **32**, wherein the removed lymphatic fluid is analyzed to monitor one or more indicators of cancer metastasis of the patient.

34. The method of claim **32**, analyzing the removed lymphatic fluid comprises identifying at least one of type oft-cells and number oft-cells in the fluid to diagnose remission or recurrence of cancer within the patient's body.

35. The method of claim **32**, wherein the removed lymphatic fluid is analyzed to quantify tumor antigens or mediators in the fluid to determine the cancer status of the patient.

36. The method of claim **32**, wherein the removed lymphatic fluid is analyzed to monitor cancer status based on detecting or quantifying circulating t-cell surface markers or substances found in circulating lymph that have been released by tumor cells.

37. The method of claim **27**, further comprising infusing one or more medications or biologics into the thoracic duct through the tubular member to stimulate growth to treat lymphedema within the patient's lymphatic system.

38. A method for diagnosing, monitoring, or treating a patient via a thoracic duct of the patient's body, comprising: providing a tubular member comprising a proximal end, a distal end sized for introduction into the patient's body, and an expandable member on the distal end; introducing the distal end of the tubular member into the patient's vasculature via a percutaneous access site with the expandable member in a contracted condition; advancing the tubular member until the distal end is disposed within a junction of the patient's left internal jugular vein and left subclavian vein; manipulating the tubular member to direct the distal end into the thoracic duct; expanding an expandable member on the distal portion adjacent the distal tip to substantially isolate the thoracic duct from the left internal jugular vein and left subclavian vein; and infusing one or more fluids into the thoracic duct through the tubular member.

39. The method of claim **38**, wherein infusing one or more fluids comprises infusing one or more medications or biologics into the thoracic duct through the tubular member to stimulate growth to treat lymphedema within the patient's lymphatic system.

40. The method of claim **38**, wherein infusing one or more fluids comprises:

- infusing contrast through the tubular member into the thoracic duct; and
- imaging the patient's lymphatic system to diagnose chylothorax.

41. The method of claim **40**, wherein the imaging identifies a target site having a breach within the patient's lymphatic system, the method further comprising introducing a repair device into the thoracic duct to repair the breach at the target site.

42. The method of claim **41**, wherein the repair device comprises a prosthesis introduced into the target site over a wire.

43. The method of claim **41**, wherein the repair device comprises a sealing material introduced into the target site.

44. A system for performing a medical procedure via a thoracic duct of a patient's body, comprising:

a tubular member comprising a proximal end, a distal end sized for introduction into the patient's body into a thoracic duct, a lumen extending between the proximal and distal ends for removing fluid from a thoracic duct, and an expandable member on the distal end; and

an ex-vivo analyzer coupled to the proximal end of the tubular member and communicating with the lumen for analyzing lymphatic fluid removed from the thoracic duct.

45. The system of claim **44**, wherein analyzer is configured to analyze lymphatic fluid according to any preceding method.

* * * * *

专利名称(译)	用于进入淋巴系统的装置和方法		
公开(公告)号	US20140303461A1	公开(公告)日	2014-10-09
申请号	US14/214882	申请日	2014-03-15
[标]申请(专利权)人(译)	CALLAGHAN MATTHEW J LEEFLANG 斯蒂芬一 EVERSULL CHRISTIAN 小号		
申请(专利权)人(译)	卡拉汉 MATTHEW J. LEEFLANG, 斯蒂芬 A. EVERSULL, CHRISTIAN S.		
当前申请(专利权)人(译)	卢甘斯克、LLC		
[标]发明人	CALLAGHAN MATTHEW J LEEFLANG STEPHEN A EVERSULL CHRISTIAN S		
发明人	CALLAGHAN, MATTHEW J. LEEFLANG, STEPHEN A. EVERSULL, CHRISTIAN S.		
IPC分类号	A61M1/14 A61M25/04 A61B5/00 A61M1/00		
CPC分类号	A61M1/14 A61M1/008 A61M25/04 A61M2202/0405 A61M1/3496 A61M1/367 A61B5/41 A61M1/3609 A61M1/3653 A61M1/3659		
优先权	61/804099 2013-03-21 US 61/800161 2013-03-15 US		
其他公开文献	US10052059		
外部链接	Espacenet USPTO		

摘要(译)

提供了用于在患者体内执行医疗程序的系统和方法，所述医疗程序涉及胸导管，所述胸导管包括与患者的静脉系统连通的口。导管的远端通过患者的静脉系统引入邻近胸导管口的体腔。管状构件的远端上的可扩张构件可以邻近窦口扩张，例如，在体腔或胸导管自身内扩张，并且用于将胸导管与体腔隔离，于是可以通过经由进行医疗程序。胸导管。例如，淋巴液可以通过管状构件的内腔从胸导管中移除和/或可以通过管状构件将一种或多种药剂引入胸导管。

