



US010555680B2

(12) **United States Patent**
Thakur et al.

(10) **Patent No.:** **US 10,555,680 B2**
(45) **Date of Patent:** **Feb. 11, 2020**

(54) **REPRESENTATION AND IDENTIFICATION OF ACTIVITY PATTERNS DURING ELECTRO-PHYSIOLOGY MAPPING USING VECTOR FIELDS**

(58) **Field of Classification Search**
CPC A61B 5/042; A61B 5/044; A61B 5/04;
A61B 5/046; A61B 18/1492;
(Continued)

(71) Applicant: **Boston Scientific Scimed Inc.**, Maple Grove, MN (US)

(56) **References Cited**

(72) Inventors: **Pramodsingh H. Thakur**, Woodbury, MN (US); **Shibaji Shome**, Arden Hills, MN (US); **Shantha Arcot-Krishnamurthy**, Sammamish, WA (US); **Allan C. Shuros**, St. Paul, MN (US); **Barun Maskara**, Princeton Jct., NJ (US); **Sunipa Saha**, Shoreview, MN (US)

U.S. PATENT DOCUMENTS

4,649,924 A 3/1987 Taccardi
4,674,518 A 6/1987 Salo
(Continued)

(73) Assignee: **Boston Scientific Scimed Inc.**, Maple Grove, MN (US)

FOREIGN PATENT DOCUMENTS

CN 1253761 A 5/2000
CN 101933803 A 1/2011
(Continued)

(*) Notice: Subject to any disclaimer, the term of this patent is extended or adjusted under 35 U.S.C. 154(b) by 0 days.

OTHER PUBLICATIONS

International Search Report and Written Opinion issued in PCT/US2014/000114, dated Sep. 8, 2014, 12 pages.

(Continued)

(21) Appl. No.: **15/890,110**

Primary Examiner — Joseph A Stoklosa
Assistant Examiner — Brian M Antiskay

(22) Filed: **Feb. 6, 2018**

(74) *Attorney, Agent, or Firm* — Faegre Baker Daniels LLP

(65) **Prior Publication Data**

US 2018/0153426 A1 Jun. 7, 2018

Related U.S. Application Data

(63) Continuation of application No. 14/120,369, filed on May 14, 2014, now Pat. No. 9,918,649.
(Continued)

(57) **ABSTRACT**

A method and system for mapping an anatomical structure includes sensing activation signals of intrinsic physiological activity with a plurality of mapping electrodes disposed in or near the anatomical structure, each of the plurality of mapping electrodes having an electrode location. A vector field map which represents a direction of propagation of the activation signals at each electrode location is generated to identify a signature pattern and a location in the vector field map according to at least one vector field template. A target location of the identified signature pattern is identified according to a corresponding electrode location.

(51) **Int. Cl.**
A61B 5/04 (2006.01)
A61N 1/00 (2006.01)
(Continued)

(52) **U.S. Cl.**
CPC **A61B 5/04011** (2013.01); **A61B 5/044** (2013.01); **A61B 5/04012** (2013.01);
(Continued)

13 Claims, 5 Drawing Sheets

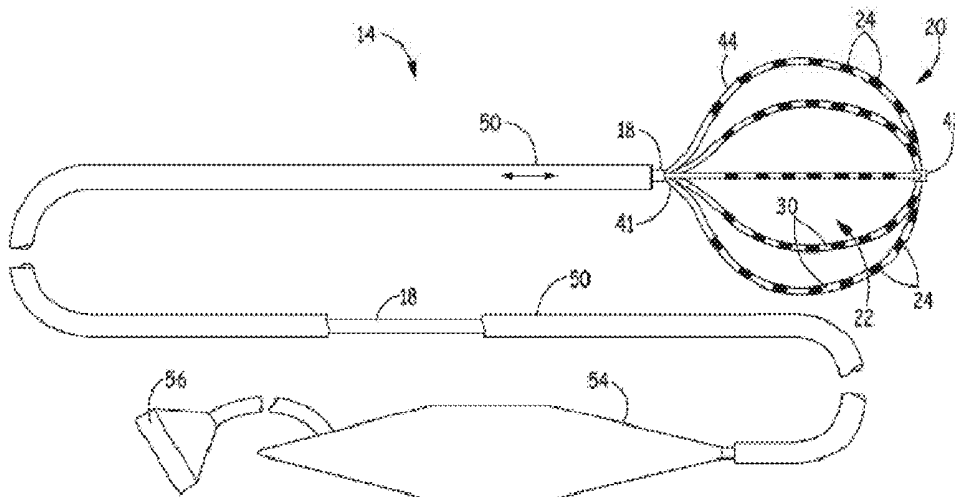

Related U.S. Application Data					
		5,971,933	A	10/1999	Gopakumaran et al.
		5,983,126	A	11/1999	Wittkamp
(60)	Provisional application No. 61/823,386, filed on May 14, 2013.	6,014,581	A	1/2000	Wayne et al.
		6,050,267	A	4/2000	Nardella et al.
		6,070,094	A	5/2000	Swanson et al.
		6,095,150	A	8/2000	Panescu et al.
(51)	Int. Cl.	6,167,296	A	12/2000	Shahidi
	<i>A61B 5/042</i> (2006.01)	6,216,027	B1	4/2001	Willis et al.
	<i>A61B 5/044</i> (2006.01)	6,226,542	B1	5/2001	Reisfeld
	<i>A61B 5/0402</i> (2006.01)	6,233,491	B1	5/2001	Kordis et al.
	<i>A61B 5/00</i> (2006.01)	6,236,886	B1	5/2001	Cherepenin et al.
	<i>A61B 5/0452</i> (2006.01)	6,240,307	B1	5/2001	Beatty et al.
	<i>G06K 9/00</i> (2006.01)	6,246,898	B1	6/2001	Vesely et al.
	<i>A61B 18/14</i> (2006.01)	6,254,536	B1	7/2001	DeVito
	<i>A61B 18/00</i> (2006.01)	6,278,894	B1	8/2001	Salo et al.
(52)	U.S. Cl.	6,298,257	B1	10/2001	Hall et al.
	CPC	6,301,496	B1	10/2001	Reisfeld
	<i>A61B 5/0422</i> (2013.01); <i>A61B 5/04023</i> (2013.01); <i>A61B 5/04525</i> (2013.01); <i>A61B 5/6852</i> (2013.01); <i>A61B 5/7221</i> (2013.01); <i>A61B 5/7246</i> (2013.01); <i>G06K 9/00496</i> (2013.01); <i>A61B 5/6858</i> (2013.01); <i>A61B 5/6859</i> (2013.01); <i>A61B 5/7203</i> (2013.01); <i>A61B 18/1492</i> (2013.01); <i>A61B 2018/00357</i> (2013.01); <i>A61B 2018/00577</i> (2013.01)	6,308,093	B1	10/2001	Armoundas et al.
		6,314,310	B1	11/2001	Ben-Haim et al.
		6,317,619	B1	11/2001	Boernert et al.
		6,318,375	B1	11/2001	Plicchi et al.
		6,360,123	B1	3/2002	Kimchi et al.
		6,368,285	B1	4/2002	Osadchy et al.
		6,400,981	B1	6/2002	Govari
		6,490,474	B1	12/2002	Willis et al.
		6,516,807	B1	2/2003	Panescu et al.
		6,547,082	B1	4/2003	Babini
(58)	Field of Classification Search	6,556,695	B1	4/2003	Packer et al.
	CPC	6,574,492	B1	6/2003	Ben-Haim et al.
	A61B 2018/00839; A61B 5/6858; A61B 2018/00351; A61B 5/04011; A61B 5/0538; A61B 2018/00214; A61B 2018/00357; A61B 2018/00577; A61B 5/0452; A61B 8/0883; A61B 2017/00053; A61B 5/04012; A61B 5/4836; A61B 5/7203; A61B 18/24; A61B 2018/00267; A61B 5/02405; A61B 5/0402; A61B 5/04085; A61B 5/04525; A61B 5/0464	6,574,498	B1	6/2003	Gilboa
	USPC	6,593,884	B1	7/2003	Gilboa et al.
	600/372-375, 377, 508-523; 606/32-38; 607/115-116, 122-123, 131	6,600,948	B2	7/2003	Ben-Haim et al.
	See application file for complete search history.	6,603,996	B1	8/2003	Beatty et al.
		6,631,290	B1	10/2003	Guck et al.
		6,640,119	B1	10/2003	Budd et al.
		6,650,927	B1	11/2003	Keidar
		6,690,963	B2	2/2004	Ben-Haim et al.
		6,701,176	B1	3/2004	Halperin et al.
		6,728,562	B1	4/2004	Budd et al.
		6,735,465	B2	5/2004	Panescu
		6,773,402	B2	8/2004	Govari et al.
		6,807,439	B2	10/2004	Edwards et al.
		6,839,588	B1	1/2005	Rudy
		6,847,839	B2	1/2005	Ciaccio et al.
		6,872,428	B2	3/2005	Yang et al.
		6,892,090	B2	5/2005	Verard et al.
		6,892,091	B1	5/2005	Ben-Haim et al.
		6,893,588	B2	5/2005	Lawson et al.
		6,939,309	B1	9/2005	Beatty et al.
		6,941,166	B2	9/2005	MacAdam et al.
		6,957,101	B2	10/2005	Porath et al.
		6,978,168	B2	12/2005	Beatty et al.
		6,984,207	B1	1/2006	Sullivan et al.
		6,990,370	B1	1/2006	Beatty et al.
		7,016,719	B2	3/2006	Rudy et al.
		7,043,292	B2	5/2006	Tarjan et al.
		7,136,694	B2	11/2006	Hadley et al.
		7,263,397	B2	8/2007	Hauck et al.
		7,505,810	B2	3/2009	Harlev et al.
		7,515,954	B2	4/2009	Harlev et al.
		7,628,757	B1	12/2009	Koh
		7,629,981	B1	12/2009	West
		7,729,752	B2	6/2010	Harlev et al.
		8,103,338	B2	1/2012	Harlev et al.
		8,137,343	B2	3/2012	Harlev et al.
		8,208,991	B2	6/2012	Markowitz et al.
		8,463,368	B2	6/2013	Harlev et al.
		8,498,699	B2	7/2013	Wells et al.
		8,571,647	B2	10/2013	Harlev et al.
		8,744,566	B2	6/2014	Harlev et al.
		8,768,440	B1	7/2014	Brodnick et al.
		9,113,809	B2	8/2015	Harlev et al.
		9,510,769	B2	12/2016	Harlev et al.
		9,636,032	B2	5/2017	Thakur et al.
		9,898,825	B2	2/2018	Rivet-Sabourin
		2002/0065459	A1	5/2002	MacAdam et al.
		2002/0151807	A1	10/2002	Goldin
		2003/0018251	A1	1/2003	Solomon
		2003/0065271	A1	4/2003	Khoury
(56)	References Cited				
	U.S. PATENT DOCUMENTS				
	4,840,182	A	6/1989	Carlson	
	4,920,490	A	4/1990	Isaacson	
	5,156,151	A	10/1992	Imran	
	5,284,142	A	2/1994	Goble et al.	
	5,297,549	A	3/1994	Beatty et al.	
	5,300,068	A	4/1994	Rosar et al.	
	5,341,807	A	8/1994	Nardella	
	5,381,333	A	1/1995	Isaacson et al.	
	5,469,858	A	11/1995	Osborne	
	5,480,422	A	1/1996	Ben-Haim	
	5,483,968	A	1/1996	Adam et al.	
	5,500,011	A	3/1996	Desai	
	5,553,611	A	9/1996	Budd et al.	
	5,568,809	A	10/1996	Ben-Haim	
	5,577,502	A	11/1996	Darrow et al.	
	5,588,429	A	12/1996	Isaacson et al.	
	5,634,469	A	6/1997	Bruder et al.	
	5,647,870	A	7/1997	Kordis et al.	
	5,662,108	A	9/1997	Budd et al.	
	5,687,737	A	11/1997	Branham et al.	
	5,697,377	A	12/1997	Wittkamp	
	5,704,365	A	1/1998	Albrecht et al.	
	5,722,402	A	3/1998	Swanson et al.	
	5,810,740	A	9/1998	Paisner	
	5,840,025	A	11/1998	Ben-Haim	
	5,840,031	A	11/1998	Crowley	
	5,846,198	A	12/1998	Killmann	
	5,848,972	A	12/1998	Triedman et al.	
	5,876,336	A	3/1999	Swanson et al.	
	5,921,982	A	7/1999	Lesh et al.	
	5,954,665	A	9/1999	Ben-Haim	

(56)

References Cited

U.S. PATENT DOCUMENTS

2003/0076277 A1 4/2003 Muramatsu et al.
 2003/0078509 A1 4/2003 Panescu
 2003/0093067 A1 5/2003 Panescu
 2003/0216630 A1 11/2003 Jersey-Willuhn et al.
 2004/0059237 A1 3/2004 Narayan et al.
 2004/0077942 A1 4/2004 Hall et al.
 2004/0097806 A1 5/2004 Hunter et al.
 2004/0158165 A1 8/2004 Yonce et al.
 2004/0243015 A1 12/2004 Smith et al.
 2004/0254437 A1 12/2004 Hauck et al.
 2005/0037489 A1 2/2005 Gepstein et al.
 2005/0038337 A1 2/2005 Edwards
 2005/0054918 A1 3/2005 Sra
 2005/0107834 A1 5/2005 Freeman et al.
 2005/0154282 A1 7/2005 Li et al.
 2005/0288599 A1 12/2005 MacAdam et al.
 2006/0085049 A1 4/2006 Cory et al.
 2006/0106375 A1 5/2006 Werneth et al.
 2006/0116575 A1 6/2006 Willis
 2006/0122526 A1 6/2006 Berenfeld et al.
 2006/0178587 A1 6/2006 Khoury
 2006/0173251 A1 8/2006 Govari et al.
 2006/0241401 A1 10/2006 Govari et al.
 2007/0016007 A1 1/2007 Govari et al.
 2007/0038078 A1 2/2007 Osadchy
 2007/0049821 A1 3/2007 Willis
 2007/0112276 A1 5/2007 Simms
 2007/0197929 A1 8/2007 Porath et al.
 2007/0232949 A1 10/2007 Saksena
 2007/0255588 A1 11/2007 Hamilton
 2007/0265539 A1 11/2007 Hastings et al.
 2007/0270688 A1 11/2007 Gelbart et al.
 2007/0270703 A1 11/2007 He et al.
 2007/0287902 A1 12/2007 Fuimaono et al.
 2007/0299351 A1 12/2007 Harlev et al.
 2007/0299352 A1 12/2007 Harlev et al.
 2007/0299353 A1 12/2007 Harlev et al.
 2008/0137934 A1 6/2008 Sakaguchi et al.
 2008/0188765 A1* 8/2008 Stolarski A61B 5/04525
 600/518
 2008/0190438 A1 8/2008 Harlev et al.
 2008/0221566 A1 9/2008 Krishnan
 2008/0222109 A1 9/2008 Sakurai
 2008/0234588 A1 9/2008 Feldman et al.
 2008/0249424 A1 10/2008 Harlev et al.
 2008/0269813 A1 10/2008 Greenhut et al.
 2009/0171274 A1 7/2009 Harlev et al.
 2009/0177072 A1 7/2009 Harlev et al.
 2009/0253976 A1 10/2009 Harlev et al.
 2009/0262979 A1 10/2009 Markowitz et al.
 2009/0264741 A1 10/2009 Markowitz et al.
 2009/0264777 A1 10/2009 Markowitz et al.
 2010/0023082 A1 1/2010 Dong et al.
 2010/0094274 A1 4/2010 Narayan et al.
 2010/0268059 A1 10/2010 Ryu et al.
 2010/0286551 A1 11/2010 Harlev et al.
 2011/0098771 A1 4/2011 Thakur et al.
 2011/0206256 A1 8/2011 Ramanathan et al.
 2011/0251505 A1 10/2011 Narayan et al.
 2011/0288605 A1 11/2011 Kaib et al.
 2012/0029504 A1 2/2012 Afonso et al.
 2012/0184858 A1 7/2012 Harlev et al.
 2012/0184863 A1 7/2012 Harlev et al.
 2012/0184865 A1 7/2012 Harlev et al.
 2012/0191087 A1 7/2012 Pachon Mateos et al.
 2012/0226110 A1 9/2012 Markowitz et al.
 2013/0035576 A1 2/2013 O'Grady et al.
 2013/0079645 A1 3/2013 Amirana et al.
 2013/0274582 A1 10/2013 Afonso et al.
 2013/0310702 A1 11/2013 Reinders et al.
 2014/0052118 A1 2/2014 Laske et al.
 2014/0073194 A1 3/2014 Lim et al.
 2014/0200874 A1 7/2014 Zeng et al.
 2014/0235986 A1 8/2014 Harlev et al.
 2014/0330150 A1 11/2014 Thakur et al.

2016/0051204 A1 2/2016 Harlev et al.
 2016/0066814 A1 3/2016 Markowitz et al.
 2016/0100770 A1 4/2016 Afonso et al.
 2017/0311833 A1 11/2017 Afonso et al.

FOREIGN PATENT DOCUMENTS

CN 102917638 A 2/2013
 EP 2204120 A1 7/2010
 EP 2427106 A 3/2012
 EP 2485194 A2 8/2012
 WO 1999005971 A1 2/1999
 WO WO2006037172 A1 4/2006
 WO 2006006324 A1 6/2006
 WO 2007035306 A2 3/2007
 WO 2007108776 A2 9/2007
 WO 2007146864 A3 12/2007
 WO 2008138009 A1 11/2008
 WO 2010054320 A1 5/2010
 WO 2010129095 A2 11/2010
 WO WO2012037471 A2 3/2012
 WO 2012092016 A1 7/2012
 WO 2013006713 A2 1/2013

OTHER PUBLICATIONS

International Search Report and Written Opinion issued in PCT/US2014/036939, dated Jul. 30, 2014, 11 pages.
 International Search Report and Written Opinion issued in PCT/US2015/017289, dated May 6, 2015, 10 pages.
 International Search Report and Written Opinion issued in PCT/US2015/017482, dated Jun. 5, 2015, 9 pages.
 International Search Report and Written Opinion issued in PCT/US2016/053613, dated Jan. 4, 2017, 11 pages.
 International Search Report and Written Opinion issued in PCT/US2016/053630, dated Jan. 17, 2017, 12 pages.
 International Search Report and Written Opinion issued in PCT/US2016/053633, dated Jan. 17, 2017, 14 pages.
 Jain et al., "Cell Therapy Attenuates Deleterious Ventricular Remodeling and Improves Cardiac Performance after Myocardial Infarction", *Circulation*, 103:1920-1927, 2001.
 Jalife, "Rotors and Spiral Waves in Atrial Fibrillation", *Journal of Cardiovascular Electrophysiology*, 14:776-780, 2003.
 Jane et al., "Alignment Methods for Averaging of High-Resolution Cardiac Signals: A Comparative Study of Performance", *IEEE Transactions on Biomedical Engineering*, 38(6):571-579, 1991.
 Japanese Office Action in JP Application No. 2009-515586, dated Jun. 26, 2012, 4 pages.
 Jia et al., "Electrophysiologic Endocardial Mapping from a Noncontact Nonexpandable Catheter: A Validation Study of a Geometry-Based Concept". *Journal of Cardiovascular Electrophysiology*, 11:1238-1251, 2000.
 Kikuchi et al., "Targeted Modification of Atrial Electrophysiology by Homogeneous Transmural Atrial Gene Transfer", *Circulation*, 111:264-270, 2005.
 Kistler et al., "Validation of Three-Dimensional Cardiac Image Integration: Use of Integrated CT Image into Electroanatomic Mapping System to Perform Catheter Ablation of Atrial Fibrillation", *Journal of Cardiovascular Electrophysiology*, 17:341-348, 2006.
 Kuklik et al., "The reconstruction, from a set of points, and analysis of the interior surface of the heart chamber", *Physiol. Meas.* 25:617-627, 2004.
 Kun, Stevan et al., "Conductance Volumetric Model of an Eccentrically Positioned Catheter Within a Three-Compartment Ellipsoidal Ventricle", *IEEE Transactions on Biomedical Engineering*, vol. 40, No. 6, Jun. 1993, pp. 589-592.
 L. Piegel, W. Tiller: *The NURBS Book*, 2nd Edition, Monographs in Visual Communication, Springer (1997).
 Laciari et al., Improved Alignment Method for Noisy High-Resolution ECG and Holter Records Using a Multiscale Cross-Correlation, *IEEE Transactions on Biomedical Engineering*, 50(3), pp. 344-353, 2003.

(56)

References Cited

OTHER PUBLICATIONS

- Liu et al., "Endocardial Potential Mapping from a Noncontact Nonexpandable Catheter: A Feasibility Study", *Annals of Biomedical Engineering*, 26:994-1009, 1998.
- Lorensen et al. "Marching Cubes: A High Resolution 3D Surface Construction Algorithm", *Computer Graphics*, 21(4):163-169, Jul. 1987.
- Makela et al., "A Review of Cardiac Image Registration Methods", *IEEE Transactions on Medical Imaging*, 21(9):1011-1021, Sep. 2002.
- Malladi, R. et al., "A Geometric Approach to Segmentation and Analysis of 3D Medical Images", *Mathematical Methods in Biomedical Image Analysis, Proceedings of the Workshop on*, Jun. 21-22, 1996, pp. 244-252.
- Mangan, Alan et al., "Partitioning 3D Surface Meshes Using Watershed Segmentation", *IEEE Transactions on Visualization and Computer Graphics*, vol. 05, No. 4, pp. 308-321, (Oct.-Dec. 1999).
- Meininger et al., "Initial Experience with a Novel Focused Ultrasound Ablation System for Ring Ablation Outside the Pulmonary Vein", *Journal of Interventional Cardiac Electrophysiology*, 8:141-148, 2003.
- Merrill, Daniel R. et al., "Electrical stimulation of excitable tissue: design of efficacious and safe protocols", *Journal of Neuroscience Methods*, vol. 141, pp. 171-198 (2005).
- Miller, "Editor's Forum—Application of Registration for Ablation: A Marriage of Technologies", *Journal of Interventional Cardiac Electrophysiology*, 11:87-89, 2004.
- Nadmanee et al., "A New Approach for Catheter Ablation of Atrial Fibrillation: Mapping of the Electrophysiologic Substrate", *Journal of the American College of Cardiology*, 43(11):2044-2053, 2004.
- Non-final Office Action issued in U.S. Appl. No. 11/451,898, dated Sep. 25, 2008, 13 pages.
- Non-final Office Action issued in U.S. Appl. No. 11/451,908, dated Sep. 4, 2008, 12 pages.
- Noseworthy et al., "The Impact of Respiration on Left Atrial and Pulmonary Venous Anatomy: Implications for Image-Guided Intervention", *Heart Rhythm*, 2(11), pp. 1173-1178, Nov. 2005.
- Pappone et al., "Robotic Magnetic Navigation for Atrial Fibrillation Ablation", *Journal of the American College of Cardiology*, 47(7):1390-1400, 2006.
- Paragios, "A Level Set Approach for Shape-Driven Segmentation and Tracking of the Left Ventricle", *IEEE Transactions on Medical Imaging*, 22(6):773-776, Jun. 2003.
- Persson et al., "A Simple Mesh Generator in MATLAB", *SIAM Review*, 46(2):329-345, 2004.
- Persson, "Mesh Generation for Implicit Geometries", *Massachusetts Institute of Technology—Thesis*, Feb. 2005.
- Pham, Dzung et al., "Current Methods in Medical Image Segmentation", *Annu. Rev. Biomed. Eng.*, 02: pp. 315-337, (2000).
- Rao et al., "Novel Noncontact Catheter System for Endocardial Electrical and Anatomical Imaging", *Annals of Biomedical Engineering*, 32(4):573-584, 2004.
- Reddy et al., "Integration of Cardiac Magnetic Resonance Imaging With Three-Dimensional Electroanatomic Mapping to Guide Left Ventricular Catheter Manipulation—Feasibility in a Porcine Model of Healed Myocardial Infarction", *Journal of the American College of Cardiology*, 44(11):2202-2213, 2004.
- Reddy et al., "Use of a Diode Laser Balloon Ablation Catheter to Generate Circumferential Pulmonary Venous Lesions in an Open-Thoracotomy Caprine Model", *Pace*, 27:52-57, 2004.
- Sanders et al., "Spectral Analysis Identifies Sites of High-Frequency Activity Maintaining Atrial Fibrillation in Humans", *Circulation*, 112:789-797, 2005.
- Sethian, "Level Set Methods and Fast Marching Methods: Evolving Interfaces in Computational Geometry, Fluid Mechanics, Computer Vision, and Materials Science", *Department of Mathematics—University of California, Berkeley, Cambridge University Press*, 1999.
- Simon et al., "Electroanatomic Mapping of the Right Atrium With a Right Atrial Basket Catheter and Three-Dimensional Intracardiac Echocardiography", *Pace*, 27:318-326, 2004.
- Smits et al., "Catheter-Based Intramyocardial Injection of Autologous Skeletal Myoblasts as a Primary Treatment of Ischemic Heart Failure", *Journal of the American College of Cardiology*, 42(12):2063-2069, 2003.
- Solomon et al., "Real-Time Cardiac Catheter Navigation on Three-Dimensional CT Images", *Journal of Interventional Cardiac Electrophysiology*, 8:27-36, 2003.
- Sra et al., "Registration of Three-Dimensional Left Atrial Computed Tomographic Images With Projection Images Obtained Using Fluoroscopy", *Circulation*, 112:3763-3768, 2005.
- Sra, Jasbir et al., "Registration of 3D Computed Tomographic Images With Interventional Systems: Implications for Catheter Ablation of Atrial Fibrillation", *J Interv Card Electrophysiol*, 16:141-148, 2006.
- Stevenson, "Radiofrequency Catheter Ablation of Ventricular Tachycardia After Myocardial Infarction", *Circulation*, 98:308-314, 1998.
- Supplemental European Search Report issued in EP Application 10772414.8, dated May 7, 2013, 6 pages.
- Supplemental European Search Report issued in EP Application No. 09824015, dated Jun. 1, 2012, 7 pages.
- Supplemental European Search Report issued in EP Application No. 09727423, dated May 15, 2012, 5 pages.
- Supplemental European Search Report issued in EP Application No. 07798369.0 dated Jul. 30, 2010, 6 pages.
- Adams et al., "Seeded Region Growing", *IEEE Transactions on Pattern Analysis and Machine Intelligence*, 16(6):641-647, 1994.
- Andras Lasso et al., "SlicerWiki VolumeClip", Dec. 25, 2014, pp. 1-4, XP55332376, retrieved from the Internet: <https://www.slicer.org/wiki/Documentation/4.4/Extensions/VolumeClip>, retrieved on Jan. 5, 2017.
- Anonymous: Solid Commands—Rhino 3-D Modeling (Rhinoeros 5), Sep. 17, 2015, XP055332631, Retrieved from Internet: http://docs.mncneel.com/rhino/5/help/en-us/seealso/sak_solidtools.htm, retrieved on Jan. 5, 2017, see under Cap, 2 pages.
- Arthur et al., "Clinical Use of Intracardiac Impedance: Current Applications and Future Perspectives", *Pace*, vol. 24, No. 4, Part 1, Apr. 2001, pp. 500-506.
- Baan, Jan et al., "Continuous Measurement of Left Ventricular Volume in Animals and Humans by Conductance Catheter", *Diagnostic Methods—Conductance Catheter*, *Circulation*, vol. 70, No. 5, 1984, pp. 812-823.
- Badics et al., "Real-Time Reconstruction of Endocardial Potential Maps in Non-Contact Cardiac Mapping", *International Journal for computation and Mathematics in Electrical and Electronic Engineering (COMPEL)*, vol. 28, No. 4, 2009.
- Ben-Haim et al., "Nonfluoroscopic, in Vivo Navigation and Mapping Technology", *Nature Medicine*, 2(12):1393-1395, Dec. 1996.
- Besl et al., "A Method for Registration of 3-D Shapes", *IEEE Transactions on Pattern Analysis and Machine Intelligence*, 14(2):239-256, Feb. 1992.
- Blomstrom-Lundqvist et al., "ACC/AHA/ESC Guidelines for the Management of Patients With Supraventricular Arrhythmias—Executive Summary", *Journal of the American College of Cardiology*, 42(8):1493-1531, 2003.
- Breithardt et al., "AHA Medical/Scientific Statement—Special Report: Standards for Analysis of Ventricular Late Potentials Using High-Resolution or Signal-Averaged Electrocardiography", *Circulation*, 83(4):1481-1488, Apr. 1991.
- Brooks et al., "Electrical Imaging of the Heart", *IEEE Signal Processing Magazine*, pp. 24-42, 1997.
- Buneo, Christopher A., *Analyzing Neural Responses with Vector Fields*, *Journal of Neuroscience Methods*, vol. 197, 2011, pp. 109-117.
- Caspi et al., "Stem Cell Research: Regenerating the Heart Using Human Embryonic Stem Cells—from Cell to Bedside", *IMAJ* 8:208-214, 2006.
- Cheney et al., "Electrical Impedance Tomography", *SIAM Review* 41(1):85-101, 1999.
- Communication pursuant to Article 94(3) EPC issued in EP Application No. 07 798 369.0, dated Nov. 17, 2011, 5 pages.

(56)

References Cited

OTHER PUBLICATIONS

- De Groot et al., "Three-Dimensional Catheter Positioning During Radiofrequency Ablation in Patients: First Application of a Real-Time Position Management System", *Journal of Cardiovascular Electrophysiology*, 11(11):1183-1192, Nov. 2000.
- Donahue et al., "Focal Modification of Electrical Conduction in the Heart by Viral Gene Transfer", *Nature Medicine*, 6(12):1395-1398, 2000.
- Dong et al., "Integrated Electroanatomic Mapping With Three-Dimensional Computed Tomographic Images for Real-Time Guided Ablations", *Circulation* 113:186-194, 2006.
- Durrer et al., "Total Excitation of the Isolated Human Heart", *Circulation*, vol. XLI, pp. 899-912, 1970.
- E. J. Haug et al.: *Design Sensitivity Analysis of Structural Systems*, Mathematics in Science and Engineering, vol. 177 (1986).
- Ector et al., "Cardiac Three-Dimensional Magnetic Resonance Imaging and Fluoroscopy Merging—a New Approach for Electroanatomic Mapping to Assist Catheter Ablation", *Circulation*, (Dec. 13, 2005), pp. 3769-3776.
- Extended European Search Report issued in EP Application No. 10 772 414, dated May 7, 2013, 6 pages.
- Fletcher, R. "Chapter 6: Sums of Squares and Nonlinear Equations," *Practical Methods of Optimization*, 2nd Edition, J. Wiley & Sons, pp. 110-119 (1987).
- Friedman, "Catheter Cryoablation of Cardiac Arrhythmias", *Current Opinion in Cardiology*, 20:48-54, 2005.
- Friedman, "Novel Mapping Techniques for Cardiac Electrophysiology", *Heart* 2002, 87:575-582.
- Geddes, L.A. et al., "Criteria for the Selection of Materials for Implanted Electrodes", *Annals of Biomedical Engineering*, vol. 31, pp. 879-890 (2003).
- Gepstein et al., "A Novel Method for Nonfluoroscopic Catheter-Based Electroanatomical Mapping of the Heart", *Circulation* 95:1611-1622, 1997.
- Gitosusastro et al., "Performance Derivative Calculations and Optimization Process, *IEEE Transactions on Magnetics*, vol. 25, No. 4 (Jul. 1989) pp. 2834-2839.
- Hansen: *Rank-Deficient and Discrete III-Posed Problems: Numerical Aspects of Linear Inversion*, SIAM, Philadelphia, USA, pp. 100-103, 1998.
- He, Ye H. et al., "An Interactive Graphical System for Automated Mapping and Display of Cardiac Rhythms", *Journal of Electrocardiology*, vol. 32, No. 3, 1999, 17 pages.
- He, Ye H., "An interactive graphical system for automated mapping and display cardiac rhythms", *Journal of Electrocardiology*, vol. 32, No. 3, Jul. 1, 1999, pp. 225-241.
- Holm, Magnus et al. A New Method for Analysis of Atrial Activation During Chronic Atrial Fibrillation in Man. *IEEE Transactions on Biomedical Engineering*, 43(2): 198-210, Feb. 1996.
- Huang, Yi-Chih et al., "Development of a Third Generation Intraventricular Impedance Imaging (III) System: Evaluation of Hardware Design", *Engineering in Medicine and Biology Society, Proceedings of the 19th Annual International Conference of the IEEE*, Oct. 30-Nov. 2, 1997 vol. 6, pp. 336-338 (1997).
- International Preliminary Report on Patentability in PCT/US2007/070854, dated Dec. 16, 2008, 9 pages.
- International Preliminary Report on Patentability in PCT/US2009/061277, dated May 3, 2011 11 pages.
- International Preliminary Report on Patentability in PCT/US2010/027568 dated Oct. 25, 2011, 4 pages.
- International Preliminary Report on Patentability issued in PCT/US2008/052385 dated Aug. 11, 2009, 6 pages.
- International Preliminary Report on Patentability issued in PCT/US2009/036099, dated Oct. 14, 2010, 20 pages.
- International Preliminary Report on Patentability issued in PCT/US2010/027436, dated Nov. 9, 2011, 4 pages.
- International Preliminary Report on Patentability issued in PCT/US2014/000114, dated Nov. 26, 2015, 9 pages.
- International Preliminary Report on Patentability issued in PCT/US2014/036939, dated Nov. 19, 2015, 8 pages.
- International Preliminary Report on Patentability issued in PCT/US2015/0017289 dated Sep. 15, 2016, 8 pages.
- International Preliminary Report on Patentability issued in PCT/US2015/017482 dated Sep. 15, 2016, 4 pages.
- International Search Report and the Written Opinion in PCT/US08/52385 dated Aug. 8, 2008, 11 pages.
- International Search Report and Written Opinion in PCT/US2010/027568, dated Nov. 4, 2010, 6 pages.
- International Search Report and Written Opinion in PCT/US2012/020946, dated May 7, 2012, 15 pages.
- International Search Report and Written Opinion issued in PCT/US2007/070854, dated Sep. 12, 2008, 10 pages.
- International Search Report and Written Opinion issued in PCT/US2009/036099, dated Apr. 28, 2009, 21 pages.
- International Search Report and Written Opinion issued in PCT/US2009/061277, dated Apr. 8, 2010, 12 pages.
- International Search Report and Written Opinion issued in PCT/US2010/027436 dated Oct. 27, 2010, 10 pages.
- Supplementary European Search Report issued in EP Application No. 08728501, dated Feb. 25, 2011, 4 pages.
- Taccardi et al., "A New Intracavitary Probe for Detecting the Site of the Origin of Ectopic Ventricular Beats During One Cardiac Cycle", *Circulation*, 75(1):272-281, 1987.
- Thal et al., "Novel Applications in Catheter Ablation", *Journal of Interventional Cardiac Electrophysiology*, 13:17-21, 2005.
- Thiagalingam et al., "Noncontact Mapping of the Left Ventricle: Insights from Validation With Transmural Contact Mapping", *Pace*, 27:570-578, 2004.
- Voth, "The Inverse Problem of Electrocardiography: Industrial Solutions and Simulations", *BEM and NFSI Conference Proceedings*, Minneapolis, MN, May 12-15, 2005, pp. 191-194.
- Wittkamp et al., "LocaLisa: New Technique for Real-Time 3-Dimensional Localization of Regular Intracardiac Electrodes", *Circulation*, 99:1312-1317, 1999.
- Yezzi, Anthony et al., "A Geometric Snake Model for Segmentation of Medical Imagery", *IEEE Transactions on Medical Imag*, vol. 16, No. 2, Apr. 1997.
- International Preliminary Report on Patentability issued in PCT/US2016/053613, dated Apr. 5, 2018, 7 pages.
- International Preliminary Report on Patentability issued in PCT/US2016/053630, dated Apr. 5, 2018, 7 pages.
- International Preliminary Report on Patentability issued in PCT/US2016/053633, dated Apr. 5, 2018, 9 pages.

* cited by examiner

Fig. 1

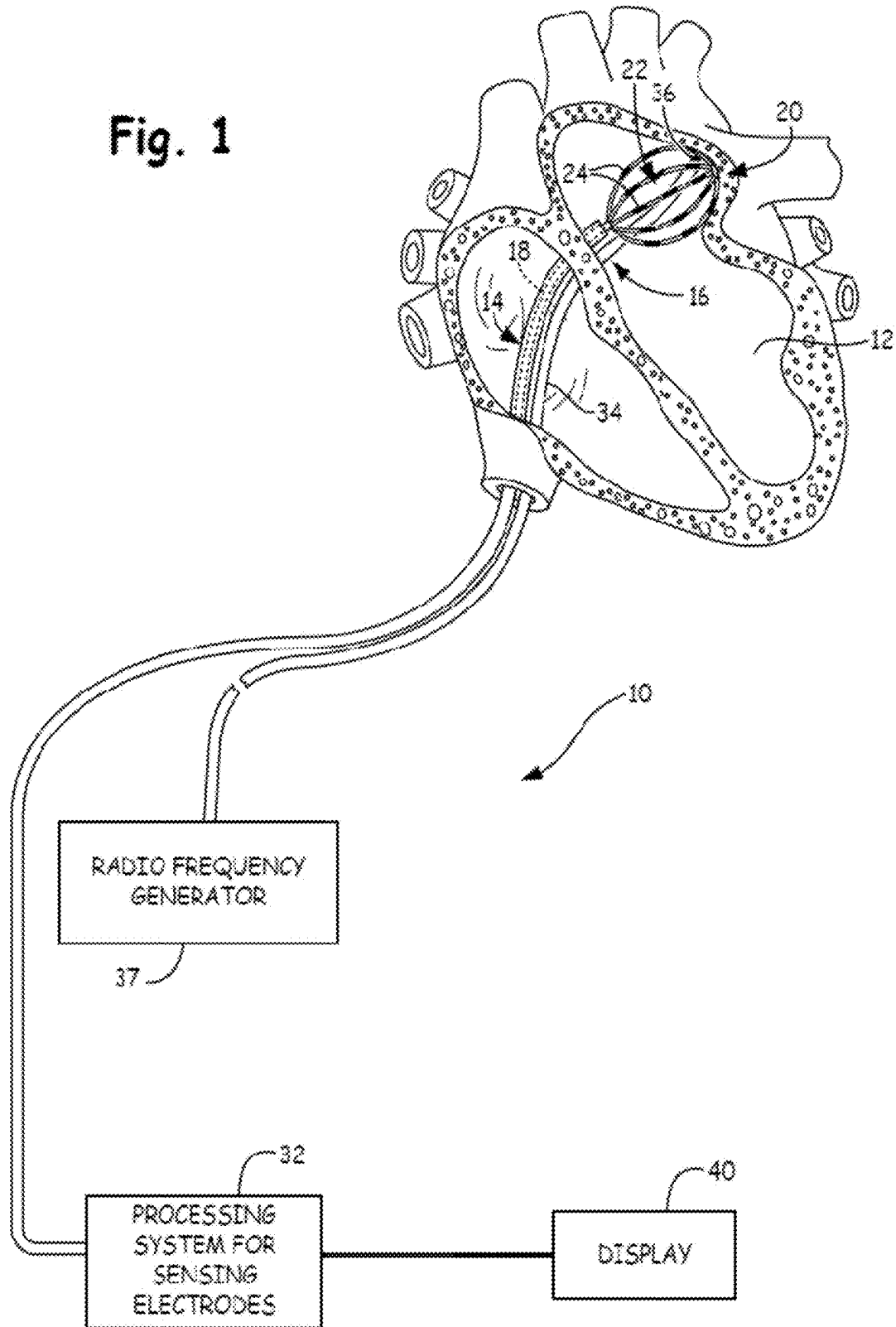

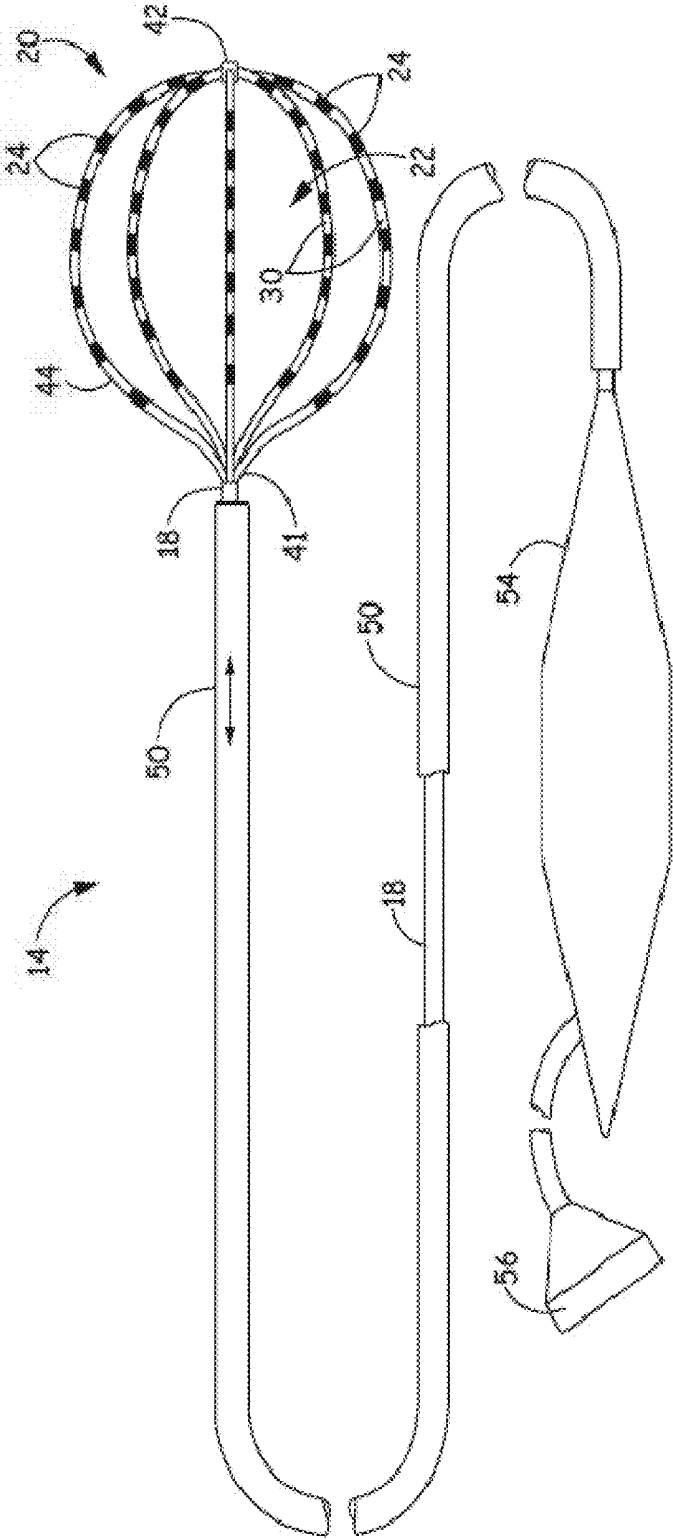

FIG. 2

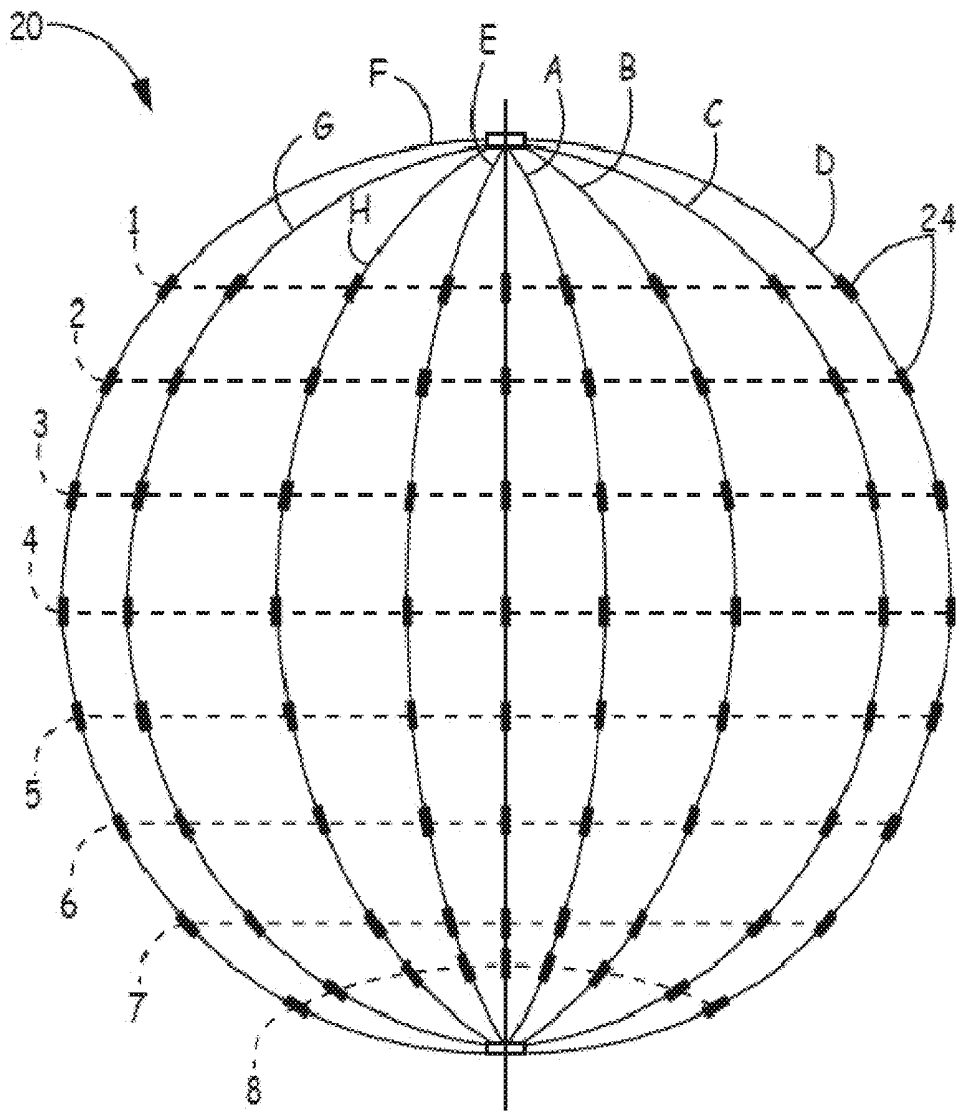

FIG. 3

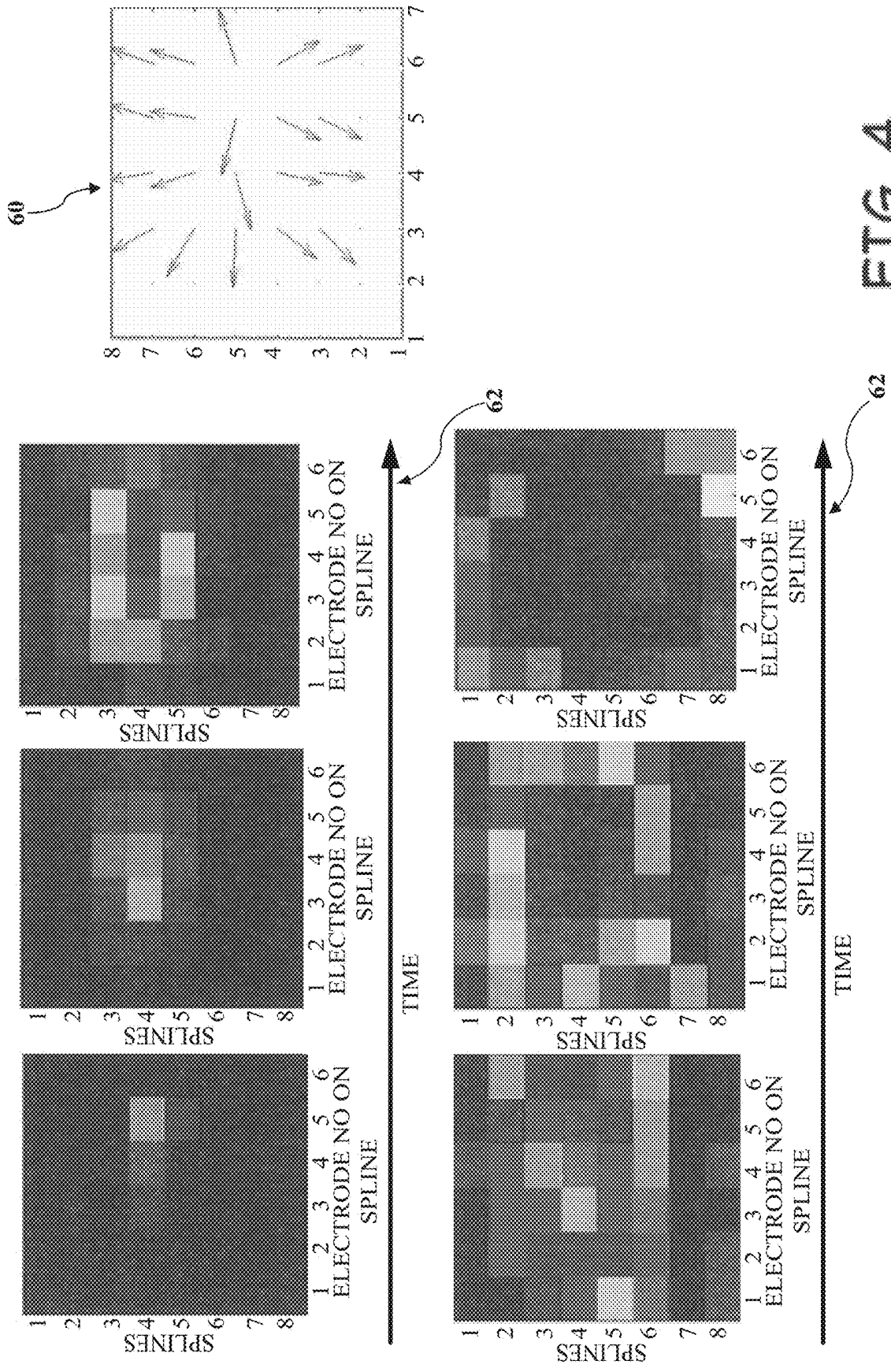
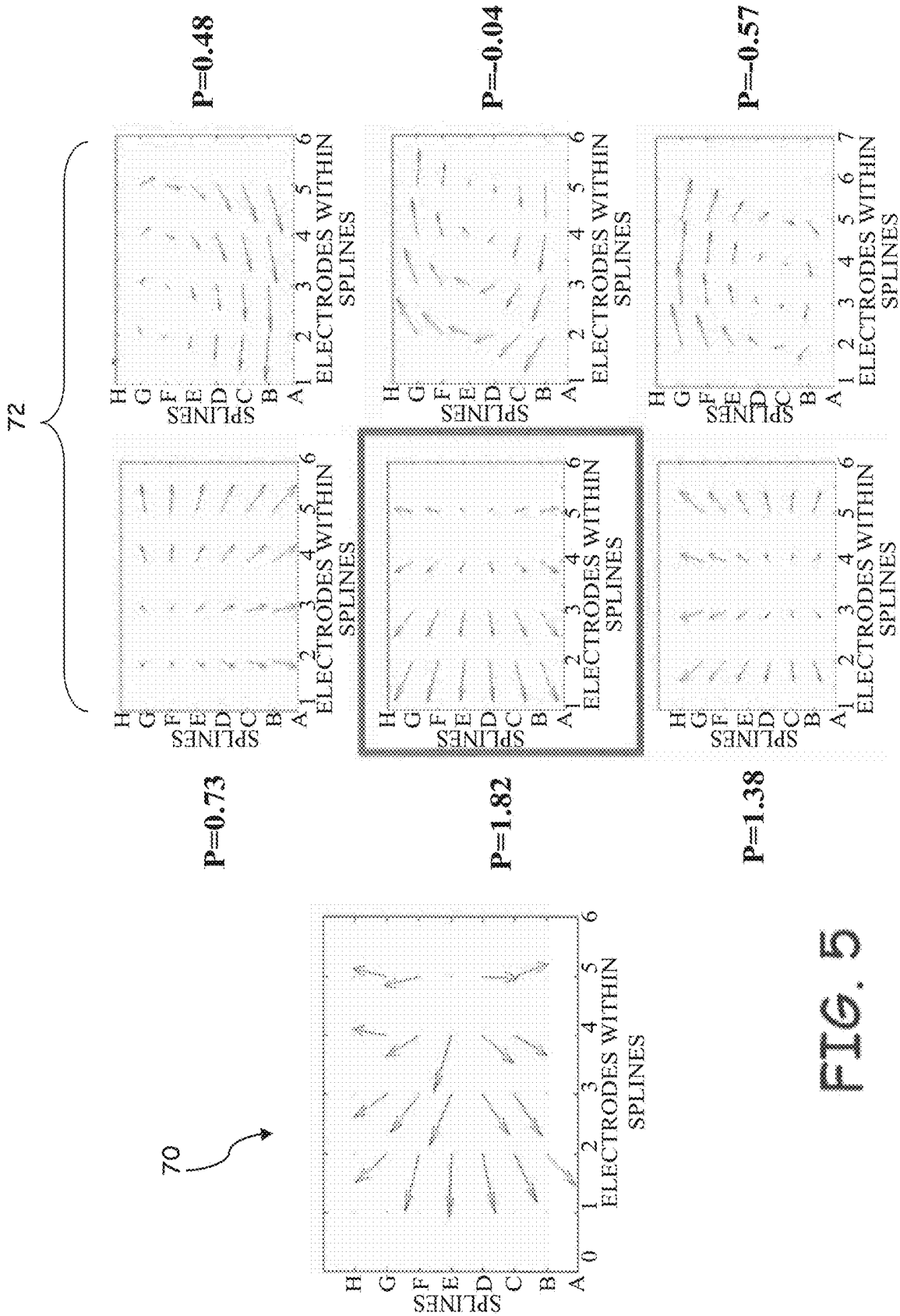

FIG. 4



1

**REPRESENTATION AND IDENTIFICATION
OF ACTIVITY PATTERNS DURING
ELECTRO-PHYSIOLOGY MAPPING USING
VECTOR FIELDS**

**CROSS-REFERENCE TO RELATED
APPLICATION**

This application is a continuation of U.S. application Ser. No. 14/120,369, filed May 14, 2014, which claims priority to Provisional Application No. 61/823,386, filed May 14, 2013, which is herein incorporated by reference in its entirety.

TECHNICAL FIELD

The present disclosure relates to cardiac mapping systems. More specifically, the present disclosure relates to a cardiac mapping system configured to display persistent data visualization during an electrophysiological study.

BACKGROUND

Diagnosing and treating heart rhythm disorders often involves the introduction of a catheter having a plurality of sensors/probes into a cardiac chamber through the surrounding vasculature. The sensors detect electric activity of the heart at sensor locations in the heart. The electric activity is generally processed into electrogram signals that represent signal propagation through cardiac tissue at the sensor locations.

Systems can be configured to display the electrical signals detected in the cardiac chamber as an activation map based on voltages detected. These activation maps may require interpolation of the detected voltages to get a finer scale of visualization across multiple electrodes of, for example, a basket catheter adapted for electrophysiological sensing. Furthermore, the decreased range of voltage signals can make automated pattern matching and classification challenging. Robust and reliable visualization of activation signals is paramount to identify accurate therapy targets during mapping. Therefore, it may be beneficial to provide a vector field pattern matching to identify aberrant electrical signals.

SUMMARY

In Example 1, a method for mapping an anatomical structure, the method includes sensing activation signals of intrinsic physiological activity with a plurality of mapping electrodes disposed in or near the anatomical structure, each of the plurality of mapping electrodes having an electrode location, generating a vector field map which represents a direction of propagation of the activation signals at each electrode location, identifying a signature pattern and a location in the vector field map according to at least one vector field template.

In Example 2, the method according to Example 1, wherein generating the vector field map further includes determining a vector of propagation at each electrode which represents a direction of propagation of the sensed activation signal with respect to at least one adjacent electrode.

In Example 3, the method according to either of Example 1 and 2, wherein generating the vector field map further includes determining a reliability index for each sensed activation signal at an electrode location according to at least one of a contact between the corresponding electrode and

2

the anatomical structure and a level of noise in the sensed activation signals, and scaling each vector of the vector field map according to the corresponding reliability index.

In Example 4, the method according to any one of Examples 1-3, wherein identifying the signature pattern further includes receiving a template bank which includes a plurality of vector field templates, each vector field template having a unique signature pattern, comparing the vector field map with each vector field template of the template bank, and identifying the signature pattern that most closely matches the generated vector field map according to a similarity index.

In Example 5, the method according to any one of Examples 1-4, wherein each unique signature pattern of the template bank includes at least one of a divergent pattern representing focal activity having a foci location and a curled pattern representing rotor activity having a core location.

In Example 6, the method according to any one of Examples 1-5, wherein comparing the vector field further includes determining a reliability index for each sensed activation signal at an electrode location according to at least one of a contact between the corresponding electrode and the anatomical structure and a level of noise in the sensed activation signal, selecting one or more vectors of the vector field map which meet a preselected threshold based on the determined reliability index, and comparing only the one or more selected vectors with the corresponding vectors within each vector field template of the template bank.

In Example 7, the method according to Example 1, further includes displaying at least one of the generated vector field map and the identified target location.

In Example 8, a method for mapping cardiac tissue includes sensing activation signals of cardiac activity with a plurality of mapping electrodes disposed in or near the anatomical structure, each of the plurality of mapping electrodes having an electrode location, generating a vector field map which represents a direction of propagation of the activation signals at each electrode location and identifying a signature pattern and a location in the vector field map according to at least one vector field template.

In Example 9, the method according to Example 8, wherein generating the vector field map further includes determining a vector at each electrode which represents a direction of propagation of the sensed activation signal with respect to at least one adjacent electrode.

In Example 10, the method according to either of Examples 8-9, wherein generating the vector field map further includes determining a reliability index for each sensed activation signal at an electrode location based on at least one of a contact between the corresponding electrode and adjacent cardiac tissue and a level of noise in the sensed activation signal, and scaling each vector of the vector field map according to the corresponding reliability index.

In Example 11, the method according to any one of Examples 8-10, wherein identifying the signature pattern further includes receiving a template bank which includes a plurality of vector field templates, each vector field template having a unique signature pattern comparing the vector field map with each vector field template of the template bank, and identifying the signature pattern that most closely matches the generated vector field map according to a similarity index.

In Example 12, the method according to any one of Examples 8-11, wherein each unique signature pattern of the template bank includes at least one of a divergent pattern

representing focal activity having a foci location and a curled pattern representing rotor activity having a core location.

In Example 13, the method according to any one of Examples 8-12, wherein comparing the vector field further includes determining a reliability index for each sensed activation signal at an electrode location according to a contact between the corresponding electrode and the anatomical structure selecting one or more vectors of the vector field map which meet a preselected threshold based on the determine reliability index, and compare only the one or more selected vectors with the corresponding vectors within each vector field template of the template bank.

In Example 14, a catheter system includes a plurality of mapping electrodes configured to detect activation signals of intrinsic cardiac activity, each of the plurality of mapping electrodes having an electrode location, and a mapping processor associated with the plurality of mapping electrodes, the mapping processor configured to record the detected activation signals and associate one of the plurality of mapping electrodes with each recorded activation signal, the mapping processor further configured to generate a vector field map which represents a direction of propagation of the activation signals at each electrode location, and identify a signature pattern and a location in the vector field map according to at least one vector field template.

In Example 15, the catheter system according to Example 14, wherein to generate the vector field map the processing system is further configured to determine a vector of propagation at each electrode which represents a direction of propagation of the sensed activation signal with respect to at least one adjacent electrode.

In Example 16, the catheter system according to either of Examples 14 and 15, wherein to generate the vector field map the processing system is further configured to determine a reliability index for each sensed activation signal at an electrode location according to at least one of a contact between the corresponding electrode and the anatomical structure and a level of noise in the sensed activation signal, and scale each vector of the vector field map according to the corresponding reliability index.

In Example 17, the catheter system according to any of Examples 14-16, wherein to identify the signature pattern the processing system is further configured to access a template bank which includes a plurality of vector field templates, each vector field template having a unique signature pattern, compare the vector field map with each vector field template of the template bank, and identify the signature pattern most closely matching the generated vector field map according to a similarity index.

In Example 18, the catheter system according to any one of Examples 14-17, wherein each unique signature pattern of the template bank includes at least one of a divergent pattern representing focal activity having a foci location and a curled pattern representing rotor activity having a core location.

In Example 19, the catheter system according to any one of Examples 14-18, wherein to compare the vector field the processing system is further configured to determine a reliability index for each sensed activation signal at an electrode location according to at least one of a contact between the corresponding electrode and the anatomical structure and a level of noise in the sensed activation signal, select one or more vectors of the vector field map which meet a preselected threshold based on the determine reliability index, and compare only the one or more selected

vectors with the corresponding vectors within each vector field template of the template bank.

In Example 20, the catheter system according to Example 14, further includes a display device for displaying at least one of the generated vector field map and the identified target location.

While multiple embodiments are disclosed, still other embodiments of the present invention will become apparent to those skilled in the art from the following detailed description, which shows and describes illustrative embodiments of the invention. Accordingly, the drawings and detailed description are to be regarded as illustrative in nature and not restrictive.

BRIEF DESCRIPTION OF THE DRAWINGS

FIG. 1 is a schematic view of an embodiment of a system for accessing a targeted tissue region in the body for diagnostic and therapeutic purposes.

FIG. 2 is a schematic view of an embodiment of a mapping catheter having a basket functional element carrying structure for use in association with the system of FIG. 1.

FIG. 3 is a schematic side view of an embodiment of the basket functional element including a plurality of mapping electrodes.

FIG. 4 illustrates a series of consecutive activation maps and a corresponding vector field map generated therefrom.

FIG. 5 illustrates a generated vector field map and a plurality of vector field templates employed by the processing system of FIG. 1.

While the invention is amenable to various modifications and alternative forms, specific embodiments have been shown by way of example in the drawings and are described in detail below. The intention, however, is not to limit the invention to the particular embodiments described. On the contrary, the invention is intended to cover all modifications, equivalents, and alternatives falling within the scope of the invention as defined by the appended claims.

DETAILED DESCRIPTION

FIG. 1 is a schematic view of a system 10 for accessing a targeted tissue region in the body for diagnostic or therapeutic purposes. FIG. 1 generally shows the system 10 deployed in the left atrium of the heart. Alternatively, system 10 can be deployed in other regions of the heart, such as the left ventricle, right atrium, or right ventricle. While the illustrated embodiment shows the system 10 being used for ablating myocardial tissue, the system 10 (and the methods described herein) may alternatively be configured for use in other tissue ablation applications, such as procedures for ablating tissue in the prostate, brain, gall bladder, uterus, and other regions of the body, including in systems that are not necessarily catheter-based.

The system 10 includes a mapping probe 14 and an ablation probe 16. In FIG. 1, each is separately introduced into the selected heart region 12 through a vein or artery (e.g., the femoral vein or artery) through suitable percutaneous access. Alternatively, the mapping probe 14 and ablation probe 16 can be assembled in an integrated structure for simultaneous introduction and deployment in the heart region 12.

The mapping probe 14 has a flexible catheter body 18. The distal end of the catheter body 18 carries a three-dimensional multiple electrode structure 20. In the illustrated embodiment, the structure 20 takes the form of a

basket defining an open interior space **22** (see FIG. 2), although other multiple electrode structures could be used wherein the geometry of the electrode structure and electrode locations are known. The multiple electrode structure **20** carries a plurality of mapping electrodes **24** each having an electrode location and channel. Each electrode **24** is configured to sense intrinsic physiological activity in the anatomical region on which the ablation procedure is to be performed. In some embodiments, the electrodes **24** are configured to detect activation signals of the intrinsic physiological activity within the anatomical structure, e.g., the activation times of cardiac activity.

The electrodes **24** are electrically coupled to a processing system **32**. A signal wire (not shown) is electrically coupled to each electrode **24** on the basket structure **20**. The wires extend through the body **18** of the probe **14** and electrically couple each electrode **24** to an input of the processing system **32**, as will be described later in greater detail. The electrodes **24** sense intrinsic electrical activity in the anatomical region, e.g., myocardial tissue. The sensed activity, e.g. activation signals, is processed by the processing system **32** to assist the physician by generating an anatomical map, e.g., a vector field map, to identify the site or sites within the heart appropriate for ablation. The processing system **32** identifies a near-field signal component, i.e. activation signals associated with local activation and originating from the tissue adjacent to the mapping electrode **24**, from an obstructive far-field signal component, i.e. activation signals originating from non-adjacent tissue, within the sensed activation signals. For example, in an atrial study, the near-field signal component includes activation signals originating from atrial myocardial tissue whereas the far-field signal component includes activation signals originating from the ventricular myocardial tissue. The near-field activation signal component can be further analyzed to find the presence of a pathology and to determine a location suitable for ablation for treatment of the pathology, e.g., ablation therapy.

The processing system **32** includes dedicated circuitry (e.g., discrete logic elements and one or more microcontrollers; application-specific integrated circuits (ASICs); or specially configured programmable devices, such as, for example, programmable logic devices (PLDs) or field programmable gate arrays (FPGAs)) for receiving and/or processing the acquired activation signals. In some embodiments, the processing system **32** includes a general purpose microprocessor and/or a specialized microprocessor (e.g., a digital signal processor, or DSP, which may be optimized for processing activation signals) that executes instructions to receive, analyze and display information associated with the received activation signals. In such implementations, the processing system **32** can include program instructions, which when executed, perform part of the signal processing. Program instructions can include, for example, firmware, microcode or application code that is executed by microprocessors or microcontrollers. The above-mentioned implementations are merely exemplary, and the reader will appreciate that the processing system **32** can take any suitable form.

In some embodiments, the processing system **32** may be configured to measure the intrinsic electrical activity in the myocardial tissue adjacent to the electrodes **24**. For example, in some embodiments, the processing system **32** is configured to detect intrinsic electrical activity associated with a dominant rotor or divergent activation pattern in the anatomical feature being mapped. Studies have shown that dominant rotors and/or divergent activation patterns have a role in the initiation and maintenance of atrial fibrillation,

and ablation of the rotor path, rotor core, and/or divergent foci may be effective in terminating the atrial fibrillation. In either situation, the processing system **32** processes the sensed activation signals to generate a display of relevant characteristics, such as an voltage map, a vector field map, a contour map, a reliability map, an electrogram, and the like. The relevant characteristics may be used by the physician to identify a site suitable for ablation therapy.

The ablation probe **16** includes a flexible catheter body **34** that carries one or more ablation electrodes **36**. The one or more ablation electrodes **36** are electrically connected to a radio frequency generator (RF) **37** that is configured to deliver ablation energy to the one or more ablation electrodes **36**. The ablation probe **16** is movable with respect to the anatomical feature to be treated, as well as the structure **20**. The ablation probe **16** is positionable between or adjacent to electrodes **24** of the structure **20** as the one or more ablation electrodes **36** are positioned with respect to the tissue to be treated.

The processing system **32** outputs to a device **40** the display of relevant characteristics for viewing by a physician. In the illustrated embodiment, device **40** is a CRT, LED, or other type of display, or a printer). The device **40** presents the relevant characteristics in a format most useful to the physician. In addition, the processing system **32** may generate position-identifying output for display on the device **40** that aids the physician in guiding the ablation electrode(s) **36** into contact with tissue at the site identified for ablation.

FIG. 2 illustrates an embodiment of the mapping catheter **14** including electrodes **24** at the distal end suitable for use in the system **10** shown in FIG. 1. The mapping catheter **14** has a flexible catheter body **18**, the distal end of which carries the three dimensional structure **20** configured to carry the mapping electrodes or sensors **24**. The mapping electrodes **24** sense intrinsic electrical activity, e.g., activation signals, in the myocardial tissue, the sensed activity is then processed by the processing system **32** to assist the physician in identifying the site or sites having a heart rhythm disorder or other myocardial pathology via a generated and displayed relevant characteristics. This information can then be used to determine an appropriate location for applying appropriate therapy, such as ablation, to the identified sites, and to navigate the one or more ablation electrodes **36** to the identified sites.

The illustrated three-dimensional structure **20** comprises a base member **41** and an end cap **42** between which flexible splines **44** generally extend in a circumferentially spaced relationship. As discussed above, the three dimensional structure **20** takes the form of a basket defining an open interior space **22**. In some embodiments, the splines **44** are made of a resilient inert material, such as Nitinol metal or silicone rubber, and are connected between the base member **41** and the end cap **42** in a resilient, pretensed condition, to bend and conform to the tissue surface they contact. In the illustrated embodiment, eight splines **44** form the three dimensional structure **20**. Additional or fewer splines **44** could be used in other embodiments. As illustrated, each spline **44** carries eight mapping electrodes **24**. Additional or fewer mapping electrodes **24** could be disposed on each spline **44** in other embodiments of the three dimensional structure **20**. In the illustrated embodiment, the three dimensional structure **20** is relatively small (e.g., 40 mm or less in diameter). In alternative embodiments, the three dimensional structure **20** is even smaller or larger (e.g., 40 mm in diameter or greater).

A slidable sheath **50** is movable along the major axis of the catheter body **18**. Moving the sheath **50** forward (i.e., toward the distal end) causes the sheath **50** to move over the three dimensional structure **20**, thereby collapsing the structure **20** into a compact, low profile condition suitable for introduction into and/or removal from an interior space of an anatomical structure, such as, for example, the heart. In contrast, moving the sheath **50** rearward (i.e., toward the proximal end) exposes the three dimensional structure **20**, allowing the structure **20** to elastically expand and assume the pretensed position illustrated in FIG. 2. Further details of embodiments of the three dimensional structure **20** are disclosed in U.S. Pat. No. 5,647,870, entitled "Multiple Electrode Support Structures," which is hereby expressly incorporated herein by reference in its entirety.

A signal wire (not shown) is electrically coupled to each mapping electrode **24**. The wires extend through the body **18** of the mapping catheter **20** into a handle **54**, in which they are coupled to an external connector **56**, which may be a multiple pin connector. The connector **56** electrically couples the mapping electrodes **24** to the processing system **32**. Further details on mapping systems and methods for processing signals generated by the mapping catheter are discussed in U.S. Pat. No. 6,070,094, entitled "Systems and Methods for Guiding Movable Electrode Elements within Multiple-Electrode Structure," U.S. Pat. No. 6,233,491, entitled "Cardiac Mapping and Ablation Systems," and U.S. Pat. No. 6,735,465, entitled "Systems and Processes for Refining a Registered Map of a Body Cavity," the disclosures of which are hereby expressly incorporated herein by reference.

It is noted that other multi-electrode structures could be deployed on the distal end of the mapping catheter **14**. It is further noted that the multiple mapping electrodes **24** may be disposed on more than one structure rather than, for example, the single mapping catheter **14** illustrated in FIG. 2. For example, if mapping within the left atrium with multiple mapping structures, an arrangement comprising a coronary sinus catheter carrying multiple mapping electrodes and a basket catheter carrying multiple mapping electrodes positioned in the left atrium may be used. As another example, if mapping within the right atrium with multiple mapping structures, an arrangement comprising a decapolar catheter carrying multiple mapping electrodes for positioning in the coronary sinus, and a loop catheter carrying multiple mapping electrodes for positioning around the tricuspid annulus may be used.

Although the mapping electrodes **24** have been described as being carried by dedicated mapping probes, such as the mapping catheter **14**, the mapping electrodes may be carried on non-mapping dedicated probes or multifunction probes. For example, an ablation catheter, such as the ablation catheter **16**, can be configured to include one or more mapping electrodes **24** disposed on the distal end of the catheter body and coupled to the signal processing system **32** and guidance system (not shown). As another example, the ablation electrode at the distal end of the ablation catheter may be coupled to the signal processing system **32** to also operate as a mapping electrode.

To illustrate the operation of the system **10**, FIG. 3 is a schematic side view of an embodiment of the basket structure **20** including a plurality of mapping electrodes **24**. In the illustrated embodiment, the basket structure includes mapping electrodes **24**. The mapping electrodes **24** are disposed in groups of eight electrodes (labeled 1, 2, 3, 4, 5, 6, 7, and 8) on each of eight splines (labeled A, B, C, D, E, F, G, and H). While an arrangement of sixty-four mapping

electrodes **24** is shown disposed on a basket structure **20**, the mapping electrodes **24** may alternatively be arranged in different numbers, on different structures, and/or in different positions. In addition, multiple basket structures can be deployed in the same or different anatomical structures to simultaneously obtain signals from different anatomical structures.

After the basket structure **20** is positioned adjacent to the anatomical structure to be treated (e.g., left atrium or left ventricle of the heart), the processing system **32** is configured to record the activation signals from each electrode **24** channel related to intrinsic physiological activity of the anatomical structure, i.e. the electrodes **24** measure electrical activation signals intrinsic to the physiology of the anatomical structure.

In some embodiments, the processing system **32** is configured to identify signature patterns in generated vector field maps to locate a rotor activation pattern core or divergent activation pattern foci. With the core and/or foci location, a physician can direct a therapy device, e.g. an ablation catheter, to the identified core and/or foci location to administer the therapy at the corresponding tissue location. The vector field map **60**, as illustrated in FIG. 4 (bottom), is a vector field wherein each vector represents a local direction of propagation of the activation signals sensed at each electrode **24** with respect to an adjacent or neighboring electrode **24** during a time period. FIG. 4 (top) illustrates an activation map **62** of an activation signal during atrial fibrillation propagating divergently from a focal point or foci. The processing system **32** senses the activation signals at an electrode location and determines an onset time associated with the activation signal at the current electrode location. To determine the vector corresponding to the propagating activation signal, the processing system **32** calculates a circular average of detected activation signals at adjacent or neighboring electrodes **24** according to latency between an activation signal sensed at a current electrode location and an activation signal sensed at a neighboring electrode location. In some embodiments, the processing system **32** determines each vector according to:

$$V = \arg\left(\sum_{\theta} (T_{\theta} - T_0)e^{-i\theta}\right) \quad \text{equation 1}$$

where T_0 is the onset time of an activation signal at a current electrode location, T_{θ} is the onset time of the activation signal at a neighboring electrode location located at angle θ . The angle θ is based on the angle of the adjacent neighboring electrodes **24**. For example, eight neighboring electrodes **24** can be used to determine the vector for which

$$\theta = \left[0, \frac{\pi}{4}, \frac{\pi}{2}, \frac{3\pi}{4}, \pi, \frac{5\pi}{4}, \frac{3\pi}{2}, \frac{7\pi}{4}\right].$$

To increase computational efficiency, four neighboring electrodes **24** can be employed for which

$$\theta = \left[0, \frac{\pi}{2}, \pi, \frac{3\pi}{2}\right]$$

where diagonal angles are excluded. Alternatively, the diagonal angles can be included instead for which

$$\theta = \left[\frac{\pi}{4}, \frac{3\pi}{4}, \frac{5\pi}{4}, \frac{7\pi}{4} \right].$$

The processing system 32 can be configured to average the determined vector at each electrode location over a plurality of consecutive activation signals such that each vector is generated based on an average of a plurality of activation signals sensed over a selected time period.

In some embodiments, the processing system 32 generates a reliability index for each vector based on a contact between a mapping electrode 24 and the anatomical structure in contact with or directly adjacent to the corresponding electrode 24. Surrogate measures such as impedance/conductance or signals from a force/strain sensors placed adjacent to the electrodes could be used to determine a good contact versus bad contact between the electrode and tissue. In some cases, in spite of good tissue contact it may be hard to reliably pick up activations due to noisy signal. Reliability index could quantify the level of noise on the signal using measures such as signal-to-noise ratio. The reliability index can then be used to modify each vector to convey the reliability visually to a user. For example, the line weight or color can be modified to illustrate the reliability such as a thicker line can be identified as a more reliable vector than a thinner line. Since, in a typical activation map the amplitude of the voltage at an electrode location is visualized by a varying color spectrum, the reliability index of the activation signal at the corresponding electrode location is difficult to incorporate into typical activation maps in addition to the voltage information.

In some embodiments, the processing system 32 is configured to determine a signature pattern for each vector field map. Each vector field map can be compared to one or more of a plurality of vector field templates which are stored within a template bank. The vector bank can be a database or an array or a plurality of vector templates that are stored locally in memory in the processing system 32 or can be stored in a remote location and accessed via a network or internet connection. Each vector field template includes a vector field having a signature pattern and a location associated with the signature pattern. For example, the signature pattern may include patterns related to identifying a dominant rotor and/or divergent activation pattern associated with cardiac fibrillation. Each vector field template may include a unique signature pattern having an associated location wherein signature patterns include, for example, a curled pattern which can represent rotor activity including a rotor core and/or rotor path having a core location or a divergent pattern representing focal activity having a foci location.

FIG. 5 illustrates an example of a generated vector field map 70 and six vector field templates 72 to which the processing system 32 can compare the vector field map 70. From vector field map 70, the vectors illustrate a divergent pattern with a foci location centered approximately at spline E and electrode 5. The processing system 32 can employ a distance based algorithm or a similarity based algorithm which will then compare each generated vector field to at least one of the vector field templates 72 in the template bank. The three templates 72 to the left illustrate divergent vector fields with foci locations centered in various positions, whereas the right three templates 72 illustrate curled vector fields with core locations at various positions. In some embodiments, the processing system 32 determines a similarity index P for each vector field template 72 based on a similarity algorithm applied to a generated vector field

map. A vector field over N electrodes can be considered as a single “super-vector” in N×2 dimensional space. The index P is obtained by projecting the “super-vector” of the observed vector field onto a unit vector along the direction of the super-vector of the template vector field in the N×2 dimensional space. As illustrated in FIG. 5, the template 72 with P=1.82 has the highest similarity with generated vector field map 70. The template associated with P=1.82 has a divergent pattern with a foci located between electrodes 4 & 5 between splines D & E which is very similar to the generated vector field map 70. From the identified vector field template 72 and a foci location, the processing system 32 can output to the display device 40 the location of the corresponding template foci as a candidate for ablative therapy.

To compare a generated vector field map 70 to a vector field template 72, the processing system 32 projects the vectors of the vector field map onto the vector field template and then determines a similarity index based on a similarity algorithm and/or a distance algorithm. The vector field templates 72 can be normalized according to, for example, a Frobenius norm to yield vector field templates which are represented in terms of units templates.

In some embodiments, the processing system 32 determines a reliability index for each vector of a generated vector field map 70 and selects vectors that meet a preselected reliability threshold for comparison with the template bank. In other words, the processing system 32 determines a subset of vectors from a vector field map 70 and the template matching with the vector field templates is performed with reliable vectors. The determined reliability of a vector can be influenced by the conductance of mapping electrode 24 which sensed the activation signal corresponding to the vector. For example, if 36 mapping electrodes of a total of 64 mapping electrodes have a reliable detection of activation signals based on the determined reliability index, then the processing system 32 projects the 36 vectors associated with the 36 reliable mapping electrodes 24 onto each vector field template 72 for determining a similarity index. Since only a subset of vectors are used to determine the similarity index, the processing system 32 can determine the similarity index for each template 72 with increased efficiency due to a decrease in computation time and complexity because of the reduced number of projected vectors.

In some embodiments, the processing system 32 identifies a signature pattern and its corresponding location within a subset, sub-space, or region of each vector field map 70. Signature patterns and locations can be determined for a plurality of consecutive or subsequent vector field maps 72. The processing system 32 can identify signature patterns and locations in multiple distinct and/or overlapping subsets in parallel or sequentially. The signature patterns from the subsets can be employed to identify an overall global signature pattern for each entire vector field map 70. For example, the processing system 32 can generate a ranking of the signature patterns identified in all or preselected subsets corresponding to different regions of the anatomical structure. The global signature pattern can be identified according to the top ranked signature patterns identified in the distinct of overlapping subsets.

Once all vector fields are generated and a corresponding signature patterns and locations are identified, the processing system 32 can determine signature pattern locations which are candidates for therapy, such as ablative therapy, to reduce or eliminate a cardiac pathology such as fibrillation.

Various modifications and additions can be made to the exemplary embodiments discussed without departing from

the scope of the present invention. For example, while the embodiments described above refer to particular features, the scope of this invention also includes embodiments having different combinations of features and embodiments that do not include all of the described features. Accordingly, the scope of the present invention is intended to embrace all such alternatives, modifications, and variations as fall within the scope of the claims, together with all equivalents thereof

We claim:

1. A catheter system comprising:
 - a plurality of mapping electrodes configured to detect activation signals of intrinsic cardiac activity, each of the plurality of mapping electrodes having an electrode location;
 - a mapping processor associated with the plurality of mapping electrodes, the mapping processor configured to record the detected activation signals and associate one of the plurality of mapping electrodes with each recorded activation signal, the mapping processor further configured to generate a vector field map which represents a direction of propagation of the activation signals at each electrode location, and identify a signature pattern and a location in the vector field map according to at least one vector field template, wherein to generate the vector field map the mapping processor is further configured to determine a reliability index for each detected activation signal at an electrode location according to at least one of a contact between the corresponding electrode and an anatomical structure and a level of noise in the detected activation signal, and scale each vector of the vector field map according to the corresponding reliability index, wherein to identify the signature pattern the processing system is further configured to access a template bank which includes a plurality of vector field templates, each vector field template having a unique signature pattern, compare the vector field map with each vector field template of the template bank by projecting the vectors of the vector field map onto each vector field template of the template bank, and identify the signature pattern most closely matching the generated vector field map according to a similarity index.
2. The catheter system according to claim 1, wherein to generate the vector field map the processing system is further configured to determine a vector of propagation at each electrode which represents a direction of propagation of the detected activation signal with respect to at least one adjacent electrode.
3. The catheter system according to claim 1, wherein each unique signature pattern of the template bank includes at least one of a divergent pattern representing focal activity having a foci location and a curled pattern representing rotor activity having a core location.
4. The catheter system according to claim 1, wherein to compare the vector field the processing system is further configured to determine a reliability index for each sensed activation signal at an electrode location according to at least one of a contact between the corresponding electrode and an anatomical structure and a level of noise in the sensed activation signal, select one or more vectors of the vector field map which meet a preselected threshold based on the determine reliability index, and compare only the one or more selected vectors with the corresponding vectors within each vector field template of the template bank.
5. The catheter system according to claim 1, further including:

- a display device for displaying at least one of the generated vector field map and the identified location.
6. A method for mapping an anatomical structure, the method comprising:
 - sensing activation signals of intrinsic physiological activity with a plurality of mapping electrodes disposed in or near the anatomical structure, each of the plurality of mapping electrodes having an electrode location;
 - generating, using a mapping processor, a vector field map which represents a direction of propagation of the activation signals at each electrode location, wherein generating the vector field map further includes:
 - determining a vector of propagation at each electrode which represents a direction of propagation of the sensed activation signal with respect to at least one adjacent electrode;
 - determining a reliability index for each sensed activation signal at an electrode location according to at least one of a contact between the corresponding electrode and the anatomical structure and a level of noise in the sensed activation signal; and
 - scaling each vector of the vector field map according to the corresponding reliability index; and
 - identifying, using the mapping processor, a signature pattern and a location in the vector field map according to at least one vector field template, wherein identifying the signature pattern comprises:
 - receiving a template bank which includes a plurality of vector field templates, each vector field template having a unique signature pattern;
 - comparing the vector field map with each vector field template of the template bank by projecting the vectors of the vector field map onto each vector field template of the template bank; and
 - identifying the signature pattern that most closely matches the generated vector field map according to a similarity index.
7. The method according to claim 6, wherein each unique signature pattern of the template bank includes at least one of a divergent pattern representing focal activity having a foci location and a curled pattern representing rotor activity having a core location.
8. The method according to claim 6, wherein comparing the vector field further includes
 - determining a reliability index for each sensed activation signal at an electrode location according to at least one of a contact between the corresponding electrode and the anatomical structure and a level noise in the sensed activation signal;
 - selecting one or more vectors of the vector field map which meet a preselected threshold based on the determined reliability index; and
 - comparing only the one or more selected vectors with the corresponding vectors within each vector field template of the template bank.
9. The method according to claim 6, further including: displaying at least one of the generated vector field map and the identified target location.
10. A method for mapping cardiac tissue, the method comprising:
 - sensing activation signals of cardiac activity with a plurality of mapping electrodes disposed in or near the anatomical structure, each of the plurality of mapping electrodes having an electrode location;
 - generating, using a mapping processor, a vector field map which represents a direction of propagation of the

13

activation signals at each electrode location, wherein generating the vector field map further includes:
determining a reliability index for each sensed activation signal at an electrode location based on at least one of a contact between the corresponding electrode and adjacent cardiac tissue and a level of noise in the sensed activation signal; and
scaling each vector of the vector field map according to the corresponding reliability index; and
identifying, using the mapping processor, a signature pattern and a location in the vector field map according to at least one vector field template, wherein identifying the signature pattern comprises:
receiving a template bank which includes a plurality of vector field templates, each vector field template having a unique signature pattern;
comparing the vector field map with each vector field template of the template bank by projecting, the vectors of the vector field map onto each vector field template of the template bank; and
identifying the signature pattern that most closely matches the generated vector field map according to a similarity index.

14

11. The method according to claim 10, wherein generating the vector field map further includes:
determining a vector at each electrode which represents a direction of propagation of the sensed activation signal with respect to at least one adjacent electrode.
12. The method according to claim 10, wherein each unique signature pattern of the template bank includes at least one of a divergent pattern representing focal activity having a foci location and a curled pattern representing rotor activity having a core location.
13. The method according to claim 10, wherein comparing the vector field further includes:
determining a reliability index for each sensed activation signal at an electrode location according to a contact between the corresponding electrode and the anatomical structure;
selecting one or more vectors of the vector field map which meet a preselected threshold based on the determine reliability index; and
compare only the one or more selected vectors with the corresponding vectors within each vector field template of the template bank.

* * * * *

专利名称(译)	向量场的电生理映射过程中活动模式的表示和识别		
公开(公告)号	US10555680	公开(公告)日	2020-02-11
申请号	US15/890110	申请日	2018-02-06
[标]申请(专利权)人(译)	波士顿科学西美德公司		
申请(专利权)人(译)	BOSTON SCIENTIFIC SCIMED INC.		
当前申请(专利权)人(译)	BOSTON SCIENTIFIC SCIMED INC.		
[标]发明人	THAKUR PRAMODSINGH H SHOME SHIBAJI ARCOT KRISHNAMURTHY SHANTHA SHUROS ALLAN C MASKARA BARUN SAHA SUNIPA		
发明人	THAKUR, PRAMODSINGH H. SHOME, SHIBAJI ARCOT-KRISHNAMURTHY, SHANTHA SHUROS, ALLAN C. MASKARA, BARUN SAHA, SUNIPA		
IPC分类号	A61B5/04 A61N1/00 G06K9/00 A61B5/0452 A61B5/00 A61B5/0402 A61B5/044 A61B5/042 A61B18/14 A61B18/00		
CPC分类号	A61B5/04023 A61B5/6852 A61B5/7246 A61B5/7221 G06K9/00496 A61B5/04012 A61B5/04525 A61B5/04011 A61B5/0422 A61B5/044 A61B18/1492 A61B5/6858 A61B5/7203 A61B2018/00577 A61B2018/00357 A61B5/6859		
代理机构(译)	FAEGRE BAKER丹尼尔斯律师事务所		
优先权	61/823386 2013-05-14 US		
其他公开文献	US20180153426A1		
外部链接	Espacenet		

摘要(译)

用于映射解剖结构的方法和系统包括利用布置在解剖结构中或附近的多个映射电极来感测固有生理活动的激活信号，多个映射电极中的每个具有电极位置。生成表示激活信号在每个电极位置处的传播方向的矢量场图，以根据至少一个矢量场模板来识别签名图案和矢量场图中的位置。根据相应的电极位置来识别所识别的签名图案的目标位置。

