



US010130419B2

(12) **United States Patent**  
**Deno et al.**

(10) **Patent No.:** **US 10,130,419 B2**  
(45) **Date of Patent:** **\*Nov. 20, 2018**

(54) **SYSTEM AND METHOD FOR ASSESSING EFFECTIVE DELIVERY OF ABLATION THERAPY**

(58) **Field of Classification Search**  
CPC ..... A61B 18/02; A61B 18/1492; A61B 2017/00044; A61B 2017/00199;  
(Continued)

(71) Applicant: **St. Jude Medical, Atrial Fibrillation Division, Inc.**, St. Paul, MN (US)

(56) **References Cited**

(72) Inventors: **D. Curtis Deno**, Andover, MN (US);  
**Stephan P. Miller**, Vadnais Heights, MN (US)

U.S. PATENT DOCUMENTS

(73) Assignee: **St. Jude Medical, Atrial Fibrillation Division, Inc.**, St. Paul, MN (US)

5,546,940 A 8/1996 Panescu  
6,391,024 B1 5/2002 Sun et al.  
(Continued)

(\* ) Notice: Subject to any disclaimer, the term of this patent is extended or adjusted under 35 U.S.C. 154(b) by 324 days.  
  
This patent is subject to a terminal disclaimer.

FOREIGN PATENT DOCUMENTS

JP 2001-190587 7/2001  
JP 2004-160212 10/2004  
WO 2009/065140 5/2009

*Primary Examiner* — Daniel Fowler

(21) Appl. No.: **14/872,208**

(74) *Attorney, Agent, or Firm* — Dykema Gossett PLLC

(22) Filed: **Oct. 1, 2015**

(65) **Prior Publication Data**

US 2016/0095651 A1 Apr. 7, 2016

**Related U.S. Application Data**

(63) Continuation of application No. 13/889,732, filed on May 8, 2013, now Pat. No. 9,173,611, which is a  
(Continued)

(57) **ABSTRACT**

A system and method for assessing effective delivery of ablation therapy to a tissue in a body is provided. A three-dimensional anatomical map of the tissue is generated and displayed with the map defining a corresponding volume. An index is generated corresponding to a location within the volume with the index indicative of a state of ablation therapy at the location. The index may be derived from one or more factors such as the duration an ablation electrode is present at the location, the amount of energy provided, the degree of electrical coupling between an ablation electrode and the tissue at the location and temperature. A visual characteristic (e.g., color intensity) of a portion of the anatomical map corresponding to the location is then altered responsive to the index.

(51) **Int. Cl.**  
**A61B 18/12** (2006.01)  
**A61B 18/14** (2006.01)  
(Continued)

(52) **U.S. Cl.**  
CPC ..... **A61B 18/1492** (2013.01); **A61B 5/068** (2013.01); **A61B 5/4848** (2013.01);  
(Continued)

**10 Claims, 4 Drawing Sheets**

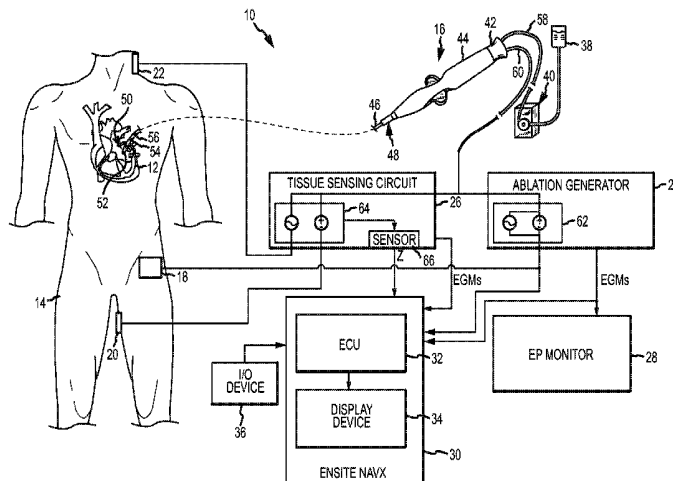

**Related U.S. Application Data**

continuation of application No. 12/622,626, filed on Nov. 20, 2009, now Pat. No. 8,454,589.

A61B 5/01; A61B 5/0538; A61B 5/068;  
A61B 5/4848; A61B 5/6843; A61B  
5/6844; A61B 5/6885; A61B 5/743; A61B  
90/37

See application file for complete search history.

(51) **Int. Cl.**

*A61B 5/00* (2006.01)  
*A61B 5/06* (2006.01)  
*A61B 90/00* (2016.01)  
*A61B 5/01* (2006.01)  
*A61B 18/02* (2006.01)  
*A61B 18/00* (2006.01)  
*A61N 7/02* (2006.01)  
*A61B 5/053* (2006.01)  
*A61B 17/00* (2006.01)

(52) **U.S. Cl.**

CPC ..... *A61B 5/6843* (2013.01); *A61B 5/6844*  
(2013.01); *A61B 5/6885* (2013.01); *A61B*  
*5/743* (2013.01); *A61B 90/37* (2016.02); *A61B*  
*5/01* (2013.01); *A61B 5/0538* (2013.01); *A61B*  
*18/02* (2013.01); *A61B 2017/00044* (2013.01);  
*A61B 2017/00199* (2013.01); *A61B*  
*2018/00351* (2013.01); *A61B 2018/00577*  
(2013.01); *A61B 2018/00642* (2013.01); *A61B*  
*2218/002* (2013.01); *A61N 7/022* (2013.01)

(58) **Field of Classification Search**

CPC ..... A61B 2018/00351; A61B 2018/00577;  
A61B 2018/00642; A61B 2218/002;

(56)

**References Cited**

U.S. PATENT DOCUMENTS

6,918,906	B2	7/2005	Long
6,936,047	B2	8/2005	Nasab
7,001,383	B2	2/2006	Keidar
7,263,397	B2	8/2007	Hauck
7,386,339	B2	6/2008	Strommer
8,403,925	B2	3/2013	Miller
8,449,535	B2	5/2013	Deno
2002/0147447	A1	10/2002	Long
2004/0078036	A1	4/2004	Keidar
2005/0203394	A1	9/2005	Hauck
2006/0184163	A1	8/2006	Breen et al.
2006/0247683	A1	11/2006	Danek et al.
2007/0049827	A1	3/2007	Donaldson
2007/0078325	A1	4/2007	Fuimaono
2007/0129633	A1	6/2007	Lee
2008/0161788	A1	7/2008	Dando
2009/0163904	A1	6/2009	Miller et al.
2009/0171345	A1	7/2009	Miller
2009/0196480	A1	8/2009	Nields
2010/0069921	A1	3/2010	Miller
2010/0228247	A1	9/2010	Paul



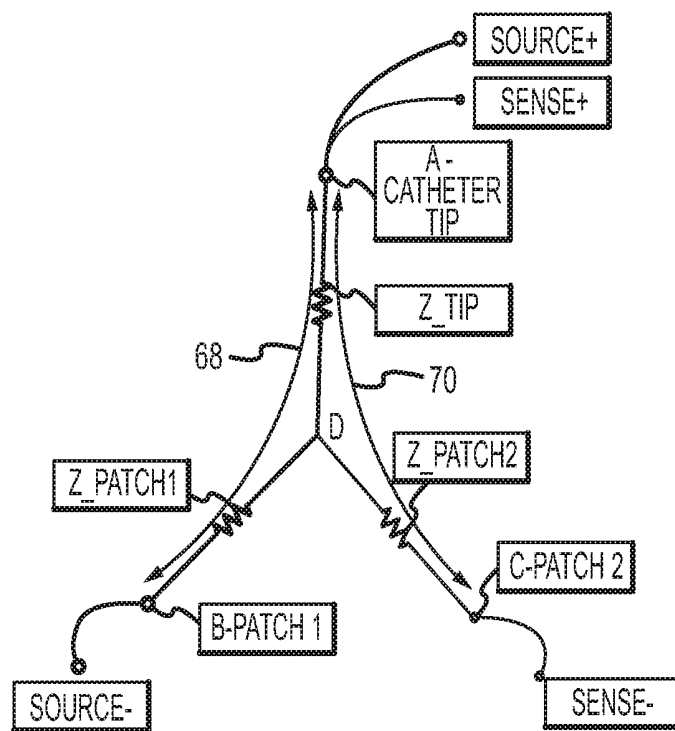

FIG.2

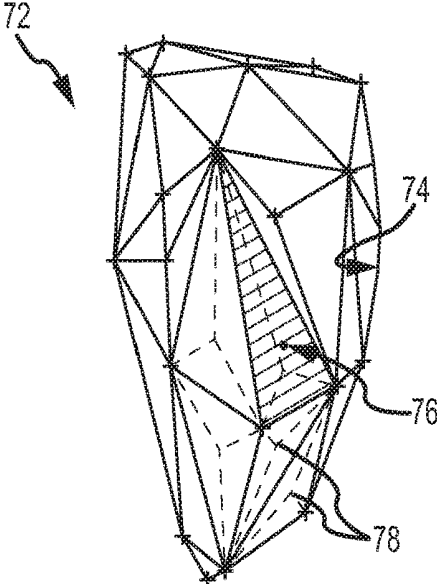

FIG.3

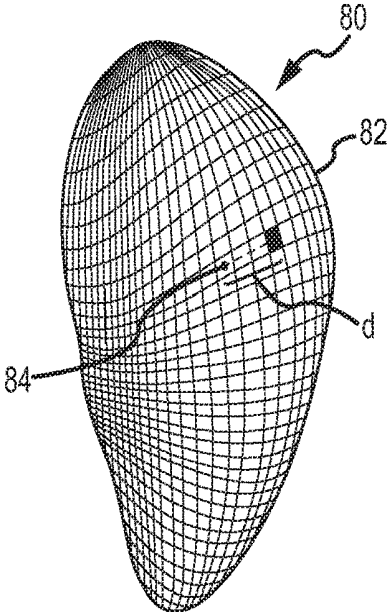

FIG.4

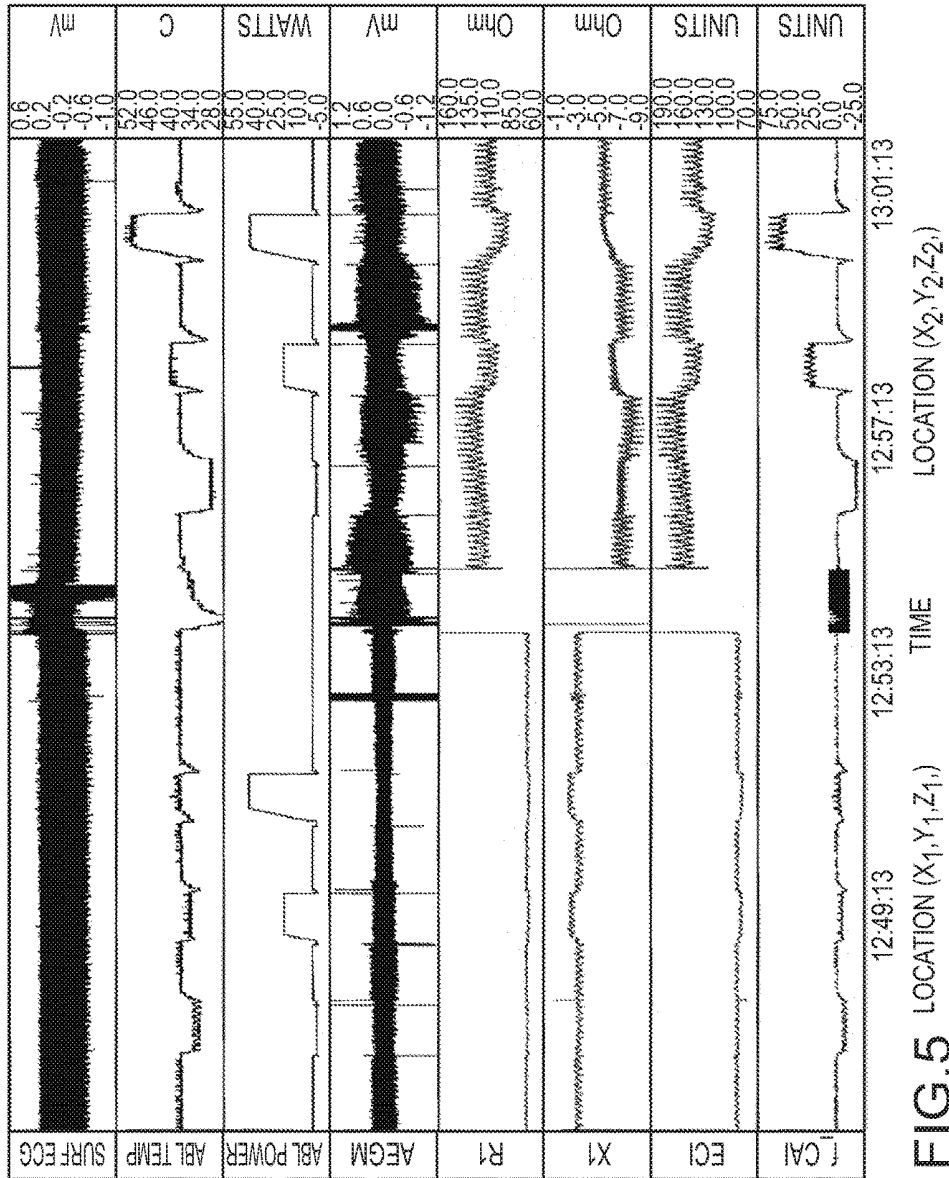

FIG.5 LOCATION (X<sub>1</sub>, Y<sub>1</sub>, Z<sub>1</sub>)

# SYSTEM AND METHOD FOR ASSESSING EFFECTIVE DELIVERY OF ABLATION THERAPY

## CROSS-REFERENCE TO RELATED APPLICATIONS

This application is a continuation of U.S. application Ser. No. 13/889,732, filed 8 May 2013 (the '732 application), now U.S. Pat. No. 9,173,611, which is a continuation of U.S. application Ser. No. 12/622,626, filed 20 Nov. 2009 (the '626 application), now U.S. Pat. No. 8,454,589. The '732 application and '626 application are each hereby incorporated by reference as though fully set forth herein.

## BACKGROUND OF THE INVENTION

### a. Field of the Invention

This invention relates to a system and method for assessing the effective delivery of ablation therapy to tissue in a body. In particular, the instant invention relates to a system and method for generating and displaying an anatomical map of the tissue and altering a visual characteristic of a portion of the map responsive to an index indicative of the state of ablation therapy.

### b. Background Art

Ablation catheters are commonly used to create tissue necrosis in cardiac tissue to correct conditions such as atrial arrhythmia (including, but not limited to, ectopic atrial tachycardia, atrial fibrillation, and atrial flutter). Arrhythmia can create a variety of dangerous conditions including irregular heart rates, loss of synchronous atrioventricular contractions and stasis of blood flow which can lead to a variety of ailments and even death. It is believed that the primary cause of atrial arrhythmia is stray electrical signals within the left or right atrium of the heart. The ablation catheter imparts ablative energy (e.g., radiofrequency energy, cryoablation, lasers, chemicals, high-intensity focused ultrasound, etc.) to cardiac tissue to create a lesion in the cardiac tissue. This lesion disrupts undesirable electrical pathways and thereby limits or prevents stray electrical signals that lead to arrhythmias.

Electroanatomical mapping systems are frequently used during cardiac ablation procedures to generate a visual representation, or anatomical map, of the endocardial surface. This visual representation permits a clinician to track the locations at which ablation therapy is provided and to view the cardiac structure and ablative lesions from a variety of angles. Tracking ablation delivery sites is important because it is often necessary to achieve a contiguous line of necrosis to disrupt undesirable electrical pathways in the tissue—despite the fact that ablation therapy often involves multiple applications of energy at discrete locations.

Conventional anatomical mapping systems used during ablation procedures require the clinician to manually mark treatment regions on the anatomical map. In particular, the clinician provides an input through a conventional input device (e.g., a mouse, keyboard, etc.) to indicate the location or locations on the map at which ablation lesions have been created. This subjective marking occurs despite numerous variabilities including movement of the ablation catheter and heart due to cardiac contractions, ventilation and movements of the clinician and variation in the application of ablative energy resulting, for example, from changing temperature or impedance levels. As a result, there may not be a strong correlation between lesions marked on the anatomical map by the clinician and the effective delivery of ablation

therapy. Clinicians therefore frequently engage in repeated and relatively time consuming electrophysiologic mapping procedures to identify locations where additional ablation therapy is required and then provide additional ablative energy to those locations—often in a repeated cycle. These problems are exacerbated for those clinicians who engage in procedures whereby the ablation catheter is intentionally moved (or “dragged”) while generating ablative energy. This type of procedure can help reduce collateral tissue damage and is more time efficient, but increases the odds that manual marking of lesion sites will be inaccurate.

The inventors herein have recognized a need for a system and method for assessing the effective delivery of ablation therapy to tissue in a body that will minimize and/or eliminate one or more of the above-identified deficiencies.

## BRIEF SUMMARY OF THE INVENTION

It is desirable to provide a system and method for assessing the effective delivery of ablation therapy to tissue in a body. In particular, it is desirable to be able to alter an anatomical map in an objective fashion to indicate the effective delivery of ablation therapy to tissue.

A system for assessing the effective delivery of ablation therapy to tissue in a body in accordance with one embodiment of the present teachings includes an electronic control unit configured to generate a three-dimensional anatomical map of the tissue. The map defines a corresponding volume. The system further includes a display configured to display the anatomical map. The electronic control unit is further configured to generate an index corresponding to a location within the volume. The index is indicative of a state of ablation therapy at the location. In accordance with various embodiments of the present teachings, the index may be determined responsive to various factors including, for example, the duration of time during which ablation energy is provided at the location, the amount of ablation energy delivered by the ablation catheter at the location, the temperature at or near the location and the degree of contact or electrical coupling between an ablation electrode and the tissue. The electronic control unit is further configured to alter, responsive to the index, a visual characteristic of a portion of the anatomical map corresponding to the location. In one embodiment according to the present teachings, the volume is divided into a plurality of voxels (volume elements) and the altered portion of the anatomical map comprises one of the voxels containing the location. In another embodiment according to the present teachings, the anatomical map defines a surface and the altered portion of the map comprises a part of the surface that is altered responsive to the index and a distance between the location and the part of the surface.

A method for assessing the effective delivery of ablation therapy to tissue in a body in accordance with another embodiment of the present teachings includes the step of generating a three-dimensional anatomical map of the tissue. The map defines a corresponding volume. The method further includes the step of displaying the anatomical map. The method further includes the step of generating an index corresponding to a location within the volume, the index indicative of a state of ablation therapy at the location. The method further includes the step of altering, responsive to the index, a visual characteristic of a portion of the anatomical map corresponding to the location.

The above-described system and method are advantageous because they provide a less subjective and more accurate map of ablation lesions than conventional systems.

The use of an index based on one or more factors or predictors indicative of the state of ablative therapy provides a more objective assessment of the effective delivery of ablation therapy while reducing the impact of variabilities such as catheter or tissue movement or changes in operating conditions. As a result, clinicians can assess the effectiveness of ablation therapy with greater confidence and reduce or eliminate the need for electrophysiologic mapping procedures and repeated ablation.

The foregoing and other aspects, features, details, utilities and advantages of the present invention will be apparent from reading the following description and claims, and from reviewing the accompanying drawings.

#### BRIEF DESCRIPTION OF THE DRAWINGS

FIG. 1 is diagrammatic view of a system in accordance with the present teachings.

FIG. 2 is a simplified schematic diagram illustrating how a degree of electrical coupling between an electrode and tissue may be determined.

FIG. 3 is a screen display illustrating one embodiment of an anatomical map altered in accordance with the present teachings.

FIG. 4 is a screen display illustrating another embodiment of an anatomical map altered in accordance with the present teachings.

FIG. 5 is a series of timing diagrams illustrating variations over time in several factors that may be used in an index to indicate effective delivery of ablation therapy.

#### DETAILED DESCRIPTION OF EMBODIMENTS OF THE INVENTION

Referring now to the drawings wherein like reference numerals are used to identify identical components in the various views, FIG. 1 illustrates one embodiment of a system 10 for one or more diagnostic and therapeutic functions including components providing an assessment of the effective delivery of ablation therapy to tissue 12 in a body 14. In the illustrated embodiment, tissue 12 comprises heart or cardiac tissue. It should be understood, however, that the present invention may be used to assess effective delivery of ablation therapy to a variety of body tissues. System 10 may include an ablation catheter 16, patch electrodes 18, 20, 22, an ablation generator 24, a tissue sensing circuit 26, an electrophysiology (EP) monitor 28 and a system 30 for visualization, mapping and navigation of internal body structures which may include an electronic control unit 32 in accordance with the present invention, a display device 34 and an input/output (I/O) device 36 among other components.

Catheter 16 is provided for examination, diagnosis and treatment of internal body tissues such as tissue 12. In accordance with one embodiment of the present teachings, catheter 16 comprises an ablation catheter. Catheter 16 may comprise, for example, an ablation catheter of the type sold commercially by St. Jude Medical, Inc. under the "SAFIRE" or "COOL PATH" trademarks and having a four millimeter tip that may be deflected in one direction (uni-directional) or multiple directions (bi-directional). In accordance with one embodiment of the present teachings, catheter 16 comprises an irrigated radio-frequency (RF) ablation catheter. It should be understood, however, that the present invention can be implemented and practiced regardless of the type of ablation energy provided (e.g., cryoablation, ultrasound, etc.). Catheter 16 is connected to a fluid source 38 having a biocom-

patible fluid such as saline through a pump 40 (which may comprise, for example, a fixed rate roller pump or variable volume syringe pump with a gravity feed supply from fluid source 38 as shown) for irrigation. Catheter 16 is also electrically connected to ablation generator 24 for delivery of RF energy. Catheter 16 may include a cable connector or interface 42, a handle 44, a shaft 46 having a proximal end 48 and a distal 50 end (as used herein, "proximal" refers to a direction toward the end of the catheter near the clinician, and "distal" refers to a direction away from the clinician and (generally) inside the body of a patient) and one or more electrodes 52, 54, 56. Catheter 16 may also include other conventional components not illustrated herein such as a temperature sensor, additional electrodes, and corresponding conductors or leads.

Connector 42 provides mechanical, fluid and electrical connection(s) for cables 58, 60 extending from pump 40 and ablation generator 24. Connector 42 is conventional in the art and is disposed at a proximal end of catheter 16.

Handle 44 provides a location for the clinician to hold catheter 16 and may further provide means for steering or guiding shaft 46 within body 14. For example, handle 44 may include means to change the length of a guidewire extending through catheter 14 to distal end 50 of shaft 46 to steer shaft 46. Handle 44 is also conventional in the art and it will be understood that the construction of handle 44 may vary.

Shaft 46 is an elongated, tubular, flexible member configured for movement within body 14. Shaft 46 support electrodes 52, 54, 56 associated conductors, and possibly additional electronics used for signal processing or conditioning. Shaft 46 may also permit transport, delivery and/or removal of fluids (including irrigation fluids and bodily fluids), medicines, and/or surgical tools or instruments. Shaft 46 may be made from conventional materials such as polyurethane and define one or more lumens configured to house and/or transport electrical conductors, fluids or surgical tools. Shaft 46 may be introduced into a blood vessel or other structure within body 14 through a conventional introducer. Shaft 46 may then be steered or guided through body 14 to a desired location such as tissue 12 with guide wires or other means known in the art.

Electrodes 52, 54, 56 are provided for a variety of diagnostic and therapeutic purposes including, for example, electrophysiological studies, catheter identification and location, pacing, cardiac mapping and ablation. In the illustrated embodiment, catheter 16 includes an ablation tip electrode 52 at distal end 50 of shaft 46 and a pair of ring electrodes 54, 56. It should be understood, however, that the number, orientation and purpose of electrodes 52, 54, 56 may vary.

Patch electrodes 18, 20, 22 provide RF or navigational signal injection paths and/or are used to sense electrical potentials. Electrodes 18, 20, 22 may also have additional purposes such as the generation of an electromechanical map. Electrodes 18, 20, 22 can be made from flexible, electrically conductive material and be configured for affixation to body 14 such that electrodes 18, 20, 22 are in electrical contact with the patient's skin. Alternatively, electrodes 18, 20, 22 can be part of a pad or support placed under the patient. Electrode 18 may function as an RF indifferent/dispersive return for the RF ablation signal. Electrodes 20, 22 may function as returns for the RF ablation signal source and/or an excitation signal generated by tissue sensing circuit 26 as described in greater detail hereinbelow. Electrodes 20, 22 are preferably spaced relatively far apart for a purpose described hereinbelow. In the illustrated embodi-

ment, electrodes **20**, **22** are located on the medial aspect of the left leg and the dorsal aspect of the neck. Electrodes **20**, **22** may alternatively be located on the front and back of the torso or in other conventional orientations.

Ablation generator **24** generates, delivers and controls RF energy used by ablation catheter **16**. Generator **24** is conventional in the art and may comprise the commercially available unit sold under the model number IBI-1500T RF Cardiac Ablation Generator, available from Irvine Biomedical, Inc. Generator **24** includes an RF ablation signal source **62** configured to generate an ablation signal that is output across a pair of source connectors: a positive polarity connector SOURCE (+) which may connect to tip electrode **52**; and a negative polarity connector SOURCE(-) which may be electrically connected by conductors or lead wires to one of patch electrodes **18**, **20**, **22** (see FIG. 2). It should be understood that the term connectors as used herein does not imply a particular type of physical interface mechanism, but is rather broadly contemplated to represent one or more electrical nodes. Source **62** is configured to generate a signal at a predetermined frequency in accordance with one or more user specified parameters (e.g., power, time, etc.) and under the control of various feedback sensing and control circuitry as is known in the art. Source **62** may generate a signal, for example, with a frequency of about 450 kHz or greater. Generator **24** may also monitor various parameters associated with the ablation procedure including impedance, the temperature at the tip of the catheter, ablation energy and the position of the catheter and provide feedback to EP monitor **28** and system **30**.

Tissue sensing circuit **26** provides a means, such as tissue sensing signal source **64**, for generating an excitation signal used in impedance measurements and means, such as complex impedance sensor **66**, for resolving the detected impedance into its component parts. Signal source **64** is configured to generate an excitation signal across source connectors SOURCE (+) and SOURCE (-) (See FIG. 2). Source **64** may output a signal having a frequency within a range from about 1 kHz to over 500 kHz, more preferably within a range of about 2 kHz to 200 kHz, and even more preferably about 20 kHz. In one embodiment, the excitation signal is a constant current signal, preferably in the range of between 20-200  $\mu$ A, and more preferably about 100  $\mu$ A. As discussed below, the constant current AC excitation signal generated by source **64** is configured to develop a corresponding AC response voltage signal that is dependent on the complex impedance of tissue **12** and is sensed by complex impedance sensor **66**. Sensor **66** resolves the complex impedance into its component parts (i.e., the resistance (R) and reactance (X) or the impedance magnitude (|Z|) and phase angle ( $\angle Z$  or  $\phi$ )). Sensor **66** may include conventional filters (e.g., bandpass filters) to block frequencies that are not of interest, but permit appropriate frequencies, such as the excitation frequency, to pass as well as conventional signal processing software used to obtain the component parts of the measured complex impedance.

It should be understood that the excitation signal from source **64** may alternatively be an AC voltage signal where the response signal comprises an AC current signal. It should also be appreciated that the excitation signal frequency is preferably outside of the frequency range of the RF ablation signal, which allows the complex impedance sensor **66** to more readily distinguish the two signals, and facilitates filtering and subsequent processing of the AC response voltage signal. The excitation signal frequency is also preferably outside the frequency range of conventionally expected electrogram (EGM) signals in the frequency range

of 0.05-1 kHz. Thus, in summary, the excitation signal preferably has a frequency that is preferably above the typical EGM signal frequencies and below the typical RF ablation signal frequencies.

Circuit **26** is also connected, for a purpose described hereinbelow, across a pair of sense connectors: a positive polarity connector SENSE (+) which may connect to tip electrode **52**; and a negative polarity connector SENSE (-) which may be electrically connected to one of patch electrodes **18**, **20**, **22** (see FIG. 2; note, however, that the connector SENSE (-) should be connected to a different electrode of electrodes **18**, **20**, **22** relative to the connector SOURCE (-) as discussed below) or another electrode **54**, **56** on catheter **16**, such as ring electrode **54** as described in commonly assigned U.S. patent application Ser. No. 11/966,232 filed on Dec. 28, 2007 and titled "System and Method for Measurement of an Impedance Using a Catheter Such as an Ablation Catheter," the entire disclosure of which is incorporated herein by reference. It should again be understood that the term connectors as used herein does not imply a particular type of physical interface mechanism, but is rather broadly contemplated to represent one or more electrical nodes.

Referring now to FIG. 2, connectors SOURCE (+), SOURCE (-), SENSE (+) and SENSE (-) form a three terminal arrangement permitting measurement of the complex impedance at the interface of tip electrode **52** and tissue **12**. Complex impedance can be expressed in rectangular coordinates as set forth in equation (1):

$$Z=R+jX \quad (1)$$

where R is the resistance component (expressed in ohms); and X is a reactance component (also expressed in ohms). Complex impedance can also be expressed in polar coordinates as set forth in equation (2):

$$Z=r\cdot e^{j\theta}=|Z|\cdot e^{j\angle Z} \quad (2)$$

where |Z| is the magnitude of the complex impedance (expressed in ohms) and  $\angle Z=\theta$  is the phase angle expressed in radians. Alternatively, the phase angle may be expressed in terms of degrees where

$$\phi = \left( \frac{180}{\pi} \right) \theta.$$

Throughout the remainder of this specification, phase angle will be preferably referenced in terms of degrees. The three terminals comprise: (1) a first terminal designated "A-Catheter Tip" which is the tip electrode **52**; (2) a second terminal designated "B-Patch 1" such as source return patch electrode **22**; and (3) a third terminal designated "C-Patch 2" such as the sense return patch electrode **20**. In addition to the ablation (power) signal generated by source **62** of ablation generator **24**, the excitation signal generated by source **64** in tissue sensing circuit **26** is also applied across the source connectors (SOURCE (+), SOURCE (-)) for the purpose of inducing a response signal with respect to the load that can be measured and which depends on the complex impedance. As described above, in one embodiment, a 20 kHz, 100  $\mu$ A AC constant current signal is sourced along the path **68**, as illustrated, from one connector (SOURCE (+), starting at node A) through the common node (node D) to a return patch electrode (SOURCE (-), node B). The complex impedance sensor **66** is coupled to the sense connectors (SENSE (+), SENSE (-)), and is configured to determine the impedance across the path **70**. For the constant current

excitation signal of a linear circuit, the impedance will be proportional to the observed voltage developed across SENSE (+)/SENSE(-), in accordance with Ohm's Law:  $Z=V/I$ . Because voltage sensing is nearly ideal, the current flows through the path **68** only, so the current through path **70** (node D to node C) due to the excitation signal is effectively zero. Accordingly, when measuring the voltage along path **70**, the only voltage observed will be where the two paths intersect (i.e. from node A to node D). Depending on the degree of separation of the two patch electrodes (i.e., those forming nodes B and C), an ever-increasing focus will be placed on the tissue volume nearest the tip electrode **52**. If the patch electrodes are physically close to each other, the circuit pathways between the catheter tip electrode **52** and the patch electrodes will overlap significantly and impedance measured at the common node (i.e., node D) will reflect impedances not only at the interface of the catheter electrode **52** and tissue **12**, but also other impedances between tissue **12** and the surface of body **14**. As the patch electrodes are moved further apart, the amount of overlap in the circuit paths decreases and impedance measured at the common node is only at or near the tip electrode **52** of catheter **16**.

Referring again to FIG. 1, EP monitor **28** is provided to display electrophysiology data including, for example, an electrogram. Monitor **28** is conventional in the art and may comprise an LCD or CRT monitor or another conventional monitor. Monitor **28** may receive inputs from ablation generator **24** as well as other conventional EP lab components not shown in the illustrated embodiment.

System **30** is provided for visualization, mapping and navigation of internal body structures. System **30** may comprise the system having the model name EnSite™ NavX™ and commercially available from St. Jude Medical, Inc. and as generally shown with reference to commonly assigned U.S. Pat. No. 7,263,397 titled "Method and Apparatus for Catheter Navigation and Location and Mapping in the Heart," the entire disclosure of which is incorporated herein by reference. Alternatively, system **30** may comprise the system sold under the name Carto™ and commercially available from Biosense Webster, Inc. or a magnetic location system such as the system sold under the name gMPS and commercially available from Mediguide Ltd. and as generally shown with reference to U.S. Pat. No. 7,386,339 entitled "Medical Imaging and Navigation System", the entire disclosure of which is incorporated herein by reference. System **30** may include electronic control unit (ECU) **32**, display device **34** and I/O device **36** among other components.

ECU **32** is provided to generate anatomical maps of tissue **12**, to generate an index indicative of a state of ablation therapy at a location within a volume defined by an anatomical map and to alter a visual characteristic of at least a portion of an anatomical map corresponding to the location. ECU **32** preferably comprises a programmable microprocessor or microcontroller, but may alternatively comprise an application specific integrated circuit (ASIC). ECU **32** may include a central processing unit (CPU) and an input/output (I/O) interface through which ECU **32** may receive a plurality of input signals including signals from sensor **66** of tissue sensing circuit **26**, from ablation generator **24** and from I/O device **36** and generate a plurality of output signals including those used to control display device **34**. In accordance with one aspect of the present invention, ECU **32** may be programmed with a computer program (i.e., software) encoded on a computer storage medium for performing one or more of the above functions.

Referring to FIG. 3, ECU **32** generates a three-dimensional anatomical map **72** for illustration on display device

**34** in a conventional manner. A plurality of electrodes at one end of catheter **16** or a conventional mapping catheter may be moved within the heart chambers by the clinician while the heart is beating. The locations of the catheter electrodes are measured, for example, using patch electrodes **18**, **20**, **22** or another sensor (e.g., a magnetic sensor (not shown)) and stored by ECU **32** as a "cloud" of points. A conventional algorithm such as a convex hull algorithm is used to construct a surface around the cloud. The most exterior points are used to create a "shell" representing the shape of the heart. Additional sampling and smoothing operations are then performed to generate the anatomical map **72** shown in FIG. 3. A more detailed explanation of the mapping process is described in the above-referenced U.S. Pat. No. 7,263,397 titled "Method and Apparatus for Catheter Navigation and Location and Mapping in the Heart," the entire disclosure of which is incorporated herein by reference. It should also be understood that ECU **32** could generate map **72** based on a real-time image such as an ultrasound image or fluoroscopic image or a pre-acquired image (e.g., an image generated by an MRI, CT, ultrasound or fluoroscopic system).

Three-dimensional map **72** defines a volume **74** comprising the space within its surface boundaries. ECU **32** is further configured generate an index (CAI) indicative of a state of ablation therapy at a location, such as location **76**, within the volume **74**. The index is derived from one or more of a plurality of factors indicative of delivery of ablative therapy to tissue **12**. These factors may include a duration of time during which ablation tip electrode **52** is present at the location or ablation therapy is provided at the location. As noted above, the location of electrode **52** can be tracked by ECU **32** by reading voltage levels on electrodes **18**, **20**, **22**. Another factor may be the amount of ablation energy provided at the location. This information can be obtained from ablation generator **24** as a measurement of RF power in the case of radio-frequency ablation and will vary based on programmed instructions for delivery of energy and feedback control such as temperature measurements (to avoid charring or steam pops) and impedance measurements (to minimize coagulum formation). Another factor is the temperature proximate the distal end **50** of catheter **16** where tip electrode **52** is located. The temperature can be measured using a conventional temperature sensor (not shown) on the distal end of shaft **46** of catheter **16**. Other exemplary factors include an impedance measurement or a change in amplitude in an electrogram both as measured by generator **24**. Additional factors may include the flow of irrigation fluid in catheter **16** as measured by a conventional flow sensor or meter (not shown) or the orientation of electrode **52** relative to tissue **12** which could be measured by a force vector sensor (not shown) on catheter **16** or through impedance measurements. Another factor indicative of the state of ablative therapy is contact pressure between electrode **52** and tissue **12** which can be measured through a conventional pressure sensor (not shown).

Another factor that is indicative of effective delivery of ablation therapy and that may be used in the index CAI is the degree of coupling, and particularly electrical coupling, between electrode **52** and tissue **12**. As discussed in greater detail hereinabove, ECU **32** can acquire one or more values for two component parts of the complex impedance from signals generated by sensor **66** of tissue sensing circuit **26** (i.e., the resistance (R) and reactance (X) or the impedance magnitude (|Z|) and phase angle ( $\phi$ ) or any combination of the foregoing or derivatives or functional equivalents thereof). ECU **32** may combine values for the two components into a single coupling index (ECI) that provides a

measure of the degree of coupling between electrode **52** and tissue **12** and, in particular, the degree of electrical coupling between electrode **52** and tissue **12**. This process and index are described more fully in commonly assigned U.S. patent application Ser. No. 12/253,637 titled "System and Method for Assessing Coupling Between an Electrode and Tissue" filed Oct. 17, 2008, the entire disclosure of which is incorporated herein by reference. As discussed in that application it should be understood that coefficients, offsets and values within the equation for the coupling index may vary depending on among other things, the desired level or predictability, the species being treated and disease states. Because impedance measurements are also influenced by the design of catheter **16** connection cables **58**, **60** or other factors, the coupling index ECI may preferably comprise a flexible equation in which coefficients and offsets are variable in response to design parameters associated with catheter **16**. Catheter **16** may include a memory such as an EEPROM that stores numerical values for the coefficients and offsets or stores a memory address for accessing the numerical values in another memory location (either in the catheter EEPROM or in another memory). ECU **32** may retrieve these values or addresses directly or indirectly from the memory and modify the coupling index ECI accordingly. The physical structure of the patient is another factor that may influence impedance measurements and the coupling index. Therefore, ECU **32** may also be configured to offset or normalize the coupling index (e.g., by adjusting coefficients or offsets within the index ECI) responsive to an initial measurement of impedance or another parameter in a particular patient. In addition, it may be beneficial to obtain and average values for the coupling index ECI responsive to excitation signals generated by source **64** at multiple different frequencies. It should be understood that while the coupling index ECI provides a measure of the degree of electrical coupling between electrode **52** and tissue **12**, measures of the degree of physical coupling can also be used as a factor in the index CAI including, for example, contact force or contact pressure as noted above.

ECU **32** may maintain, read from and update a data structure containing values for the index CAI and the factors (e.g., RF power, temperature, ECI, etc.) used to determine the index CAI with each index value (and the associated factor values) corresponding to either a discrete location, such as location **76**, within volume **74** or a plurality of locations as discussed hereinbelow. ECU **32** continuously calculates and maintains the value of the index CAI for any particular location or group of locations over time such that the index CAI represents an assessment of the instantaneous and cumulative values for the various factors that make up the index. The index CAI may therefore be represented by the following equation:

$$CAI(x, y, z, t) = \int_{t_0}^t f(x, y, z, t) dt$$

where x, y, and z represent coordinates for a location **76**, t represents time and f(x,y,z,t) is a function g of one or more of the above-described factors. For example, in one embodiment of the invention, the index CAI may be derived from the following function:

$$g = \text{ablation\_energy} * ECI$$

where ablation\_energy represents the amount of ablative energy provided at the location through generator **24** and

ECI is an index representative of the degree of electrical coupling between electrode **52** and tissue **12**. In another embodiment of the invention, the index CAI may be derived from the following function:

$$g = \alpha * \text{ablation\_energy} * ECI + \beta * \text{temperature}$$

where  $\alpha$  and  $\beta$  are constants and temperature represents the temperature proximate the distal end **50** of catheter **16**. Each factor in the index CAI may be compared to a threshold value associated with the factor to ensure that any factor forming part of the index CAI is indicative of a predetermined level of ablation therapy at the location (e.g., therapy that will result in irreversible lesions as opposed to brief and reversible exposure of the tissue to ablation). For example, the degree of coupling between electrode **52** and tissue **12** input to the index CAI may be computed as follows:

$$ECI = ECI(t) - ECI_{\text{non-contact}}$$

where  $ECI_{\text{non-contact}}$  represents a threshold value for ECI (typically  $100+/-5$ , whereas ECI is typically between 140 and 180 when in electrode **52** is in moderate contact with tissue **12**). Similarly, ablation\_energy may be calculated relative to a threshold value intended to compensate for the fact that a very low power level (e.g., 1 watt) will not result in detectable changes to tissue **12**:

$$\text{ablation\_energy} = \text{ablation\_energy}(t) - 1$$

Because measured temperatures above the internal body temperature are indicative of effective ablation therapy, a function for determining a temperature value in the index CAI may use body temperature as a threshold value:

$$\text{Temperature} = \text{Catheter\_temperature}(t) - \text{Body\_temperature}(t)$$

It should be understood that temperature values may also be impacted by irrigation, the flow rate of irrigation fluid and other design parameters for catheter **16** and that the above function could be varied to account for such parameters.

As noted hereinabove, ECU **32** may determine the index (CAI) relative to a discrete location, such as location **76**, within the volume **74**. In one embodiment of the invention, ECU **32** may further be configured to determine the location not as a discrete value, but rather in response to a plurality of measured positions of catheter **16** over a predetermined period of time. ECU **32** may determine a location by taking, for example, a mean or median value from among a plurality of positions of catheter **16** measured over a time period (e.g., between 0.2 to 2 seconds). ECU **32** may associate the cumulative CAI value over that time period with the determined location. This approach reflects the fact that ablative therapy may be applied to a number of distinct locations that are very close to one another—particularly in short interval.

It should be understood that ECU **32** may calculate values for CAI at location **76** responsive to measurements made at multiple electrodes (e.g., at electrodes **52**, **54**, **56**). For example, the degree of coupling (e.g., electrical coupling or force of contact) between each electrode **52**, **54**, **56** and tissue **12** can be assessed. Mathematical algorithms (e.g., weighting and interpolation) may be used in connection with the measurements made at the electrodes **52**, **54**, **56** to derive a more precise assessment of the degree of coupling at location **76** and, consequently, a more precise value of index CAI.

Referring again to FIG. 3, in one embodiment of the invention, ECU **32** is configured to divide the volume **74** into a plurality of volume elements or voxels **78**. A data structure is maintained by ECU **32** which correlates instantaneous and cumulative values for the index CAI and the

factors used to compute the index with each voxel **78** such that the index CAI and the factors reflect cumulative values taken at a plurality of discrete locations within each voxel **78**. In this embodiment, one factor that may be used to compute the index comprises the time in which the ablation catheter **16** is within the voxel as opposed to time spent at a single discrete location. This embodiment of the invention is advantageous given the limitations on providing precise representations of the surface of tissue **12** during mapping and the ability to deliver ablation therapy to discrete locations.

ECU **32** is configured to alter a visual characteristic of voxel **78** responsive to the index CAI. In one embodiment of the invention, the visual characteristic comprises color and, in particular, the intensity of the color. Voxels **78** containing locations **76** where effective ablation therapy is delivered may assume a certain color that becomes more intense or more opaque (illustrated in the drawings by an increase in cross-hatching) as the effectiveness of the therapy increases (as indicated by index CAI). Voxels **78** containing locations where therapy has not been provided or therapy has been relatively ineffective may be transparent or translucent to facilitate the visualization of underlying geometric structures in tissue **12**. It should be noted that the visual characteristic does not need to be altered in a linear fashion relative to changes in the index CAI. Various functions may be applied to the index CAI to emphasize specific indices or range of indices likely to represent ineffective ablative therapy. It should also be understood that the visual characteristics of voxel **78** could be altered in response to other factors or measurements in addition to the index CAI. For example, the visual characteristics of voxel **78** may be altered responsive to a measured temperature exceeding a predetermined threshold during ablation such that the appearance of the voxel is altered in multiple ways (e.g., by adjusting the intensity of the color based on index CAI and by alternating between multiple states (i.e., flashing) in the presence of excessive temperatures).

Referring to FIG. 4, in another embodiment of the invention, ECU **32** generates an anatomical map **80** that defines a surface **82**. ECU **32** is configured to alter a visual characteristic of a portion of the surface **82** responsive to the index CAI and a distance **d** between a location **84** at which CAI is computed and one or more locations on surface **82** (the relative locations being known by detecting the position of the catheter tip as discussed above and registering the coordinate system with that of map **80** in a conventional manner). ECU **32** may alter surface **82** by again adjusting the color, and particularly the intensity of the color (again illustrated by increased cross-hatching), at the surface **82** or by superimposing a marker (e.g., a disc) thereon. As discussed above, it should be understood that the visual characteristics of surface **82** may also be altered responsive to other factors or measurements in addition to the index CAI.

Referring again to FIG. 1, display device **34** is provided to display map **72** or **80** and present information permitting the clinician to assess effective delivery of ablation therapy to tissue **12**. Device **34** may also provide a variety of information relating to visualization, mapping and navigation as is known in the art including measures of electrical signals, various two and three dimensional images of the tissue **12** and three-dimensional reconstructions of the tissue **12**. Device **34** may, for example, display, or combine with map **72** or **80**, detailed computed tomography or magnetic resonance images using conventional registration and fusion processes. Device **34** may comprise an LCD monitor or other conventional display device.

I/O device **36** is provided to allow the clinician to control operation of system **30**. Device **36** may comprise a keyboard, mouse or other conventional input/output device. In accordance with one aspect of the present invention, device **36** permits the clinician to exercise a measure of control over the computation of index CAI to permit clinicians to provide appropriate weight to those factors the clinician believes are better indicators of effective ablation therapy. ECU **32** is therefore configured to receive a user input through device **36** controlling a weight accorded to at least one of the factors used by ECU to derive index CAI. In this manner, the clinician can, for example, more easily control lesion formation in sensitive areas (e.g., in cardiac tissue near the esophagus).

The above description contemplates review of the altered electroanatomical map **72** or **80** and appropriate adjustment of components of system **10** (e.g., by movement of catheter **16**) in response thereto. In an alternative embodiment of the invention, catheter **16** may be controlled automatically (e.g., robotically or magnetically) responsive, in part, to the measured values of CAI. System **30** may obtain measurements and calculate the index CAI. The location of the catheter **16** may be adjusted automatically responsive to the values of CAI using, for example, the robotic or magnetic systems described in commonly assigned U.S. patent application Ser. No. 12/622,488, the entire disclosure of which is incorporated herein by reference. As part of this process, system **30** may identify locations within volume **74** (by altering the visual characteristics of map **72** or **80**) that require review, and possibly further treatment, by a clinician.

Referring now to FIG. 5, a series of timing diagrams (in registration with each other) taken during an animal study illustrate changing values over time for several individual factors indicative of the delivery of ablation therapy by a tip electrode **52** at two locations  $(x_1, y_1, z_1)$  and  $(x_2, y_2, z_2)$  within cardiac tissue. The first location  $(x_1, y_1, z_1)$  was in the left atrium while the second location  $(x_2, y_2, z_2)$  was in the right atrium. The catheter tip was maintained out of contact with the tissue when electrode **52** was at the first location  $(x_1, y_1, z_1)$  and in moderate contact with the tissue when electrode **52** was at the second location  $(x_2, y_2, z_2)$ . The power level was varied at each location between 1 watt, 20 watts and 40 watts as illustrated in the timing diagram marked "ABL POWER". Although the amount of ablative energy delivered in each location was the same, the catheter tip temperature, the electrical coupling index (ECI) (as well as its individual component parts R1 and X1) and other values remained relatively constant over the time period in which the electrode **52** was at the first location  $(x_1, y_1, z_1)$  and varied considerably during the timer period in which the electrode **52** was at the second location  $(x_2, y_2, z_2)$ . Similarly, the index CAI remained relatively constant during the time period the electrode **52** was at the first location  $(x_1, y_1, z_1)$  and varied during the time period in which the electrode **52** was at the second location  $(x_2, y_2, z_2)$  to indicate more effective delivery of ablation therapy. In the illustrated embodiment, CAI was calculated from the following equation:

$$CAI=0.025*(ECI-90)*(ablation\_energy-3.4)+2*(temperature-37)$$

With ECI, ablation\_energy, and temperature all compared to threshold values such that each factor impacts CAI only if it is indicative of a predetermined level of ablation therapy at the location (e.g., therapy that will result in irreversible lesions as opposed to brief and reversible exposure of the tissue to ablation).

In summary, the effective delivery of ablation therapy to tissue **12** is assessed through several method steps in accordance with one embodiment of the present invention. First, a three-dimensional anatomical map **72** or **80** of the tissue **12** is generated. The map may be generated by ECU **32** in a conventional manner using values measured from the movement of a conventional mapping catheter or may be based on a real-time image such as an ultrasound image or fluoroscopic image or a pre-acquired image (e.g., an image generated by an MRI, CT, ultrasound or fluoroscopic system). The map **72** or **80** is then displayed on, for example, a conventional display device **34**. ECU **32** then generates an index CAI corresponding to a location **76** or **84** within a volume **74** or **82** defined by the map **72** or **80**, respectively. The index CAI is indicative of a state of ablation therapy at the location. Finally, a visual characteristic of a portion of the map **72** or **80** corresponding to the location **76** or **84** is altered responsive to the index.

A system and method in accordance with the present teachings offers one or more of a number of advantages. The system and method provide a less subjective and more accurate map of ablation lesions than conventional systems and methods. The use of an index based on one or more factors or predictors indicative of the state of ablative therapy provides a more objective assessment of the effective delivery of ablation therapy while reducing the impact of variabilities such as catheter or tissue movement or changes in operating conditions. As a result, clinicians can assess the effectiveness of ablation therapy with greater confidence and reduce or eliminate the need for electrophysiologic mapping procedures and repeated ablation.

Although several embodiments of this invention have been described above with a certain degree of particularity, those skilled in the art could make numerous alterations to the disclosed embodiments without departing from the scope of this invention. All directional references (e.g., upper, lower, upward, downward, left, right, leftward, rightward, top, bottom, above, below, vertical, horizontal, clockwise and counterclockwise) are only used for identification purposes to aid the reader's understanding of the present invention, and do not create limitations, particularly as to the position, orientation, or use of the invention. Joinder references (e.g., attached, coupled, connected, and the like) are to be construed broadly and may include intermediate members between a connection of elements and relative movement between elements. As such, joinder references do not necessarily infer that two elements are directly connected and in fixed relation to each other. It is intended that all matter contained in the above description or shown in the accompanying drawings shall be interpreted as illustrative only and not as limiting. Changes in detail or structure may be made without departing from the invention as defined in the appended claims.

What is claimed is:

1. A system for assessing effective delivery of ablation therapy to a tissue in a body, comprising:  
 an electronic control unit (ECU) configured to generate a map of the tissue including a first map location; wherein the ECU is further configured to:  
 receive for each factor of a plurality of factors indicative of delivery of ablation energy a corresponding threshold value;  
 acquire at the first location an actual value for each of said plurality of factors;  
 determine an index indicative of a state of ablation therapy at the first location using only the acquired

values for each of the plurality of factors that exceed corresponding threshold values; and  
 generate, at the first location, a first visual characteristic responsive to the index.

2. The system of claim 1, wherein each of the plurality of factors comprises a first exceeding factor that exceeds a corresponding first threshold value, and wherein the ECU is further configured to:

receive a first weight;  
 generate a first weighted factor by applying the first weight to the first exceeding factor; and  
 use the first weighted factor in the determining step.

3. The system of claim 1, wherein the plurality of factors comprises a group of exceeding factors that each exceeds a corresponding group of threshold values, and wherein the ECU is further configured to:

receive weights for the factors in the group of exceeding factors;  
 generate a group of weighted factors by applying the weights to the factors in the group of exceeding factors; and  
 use the group of weighted factors in the determining step.

4. The system of claim 1, wherein the plurality of factors indicative of delivery of ablation energy are selected from the group consisting of:

an amount of energy delivered at the first location;  
 a duration of time during which an ablation electrode is present at the first location;  
 a duration of time during which an ablation electrode is away from the first location;  
 an impedance measurement proximate a distal end of the ablation electrode;  
 a maximum amount of power delivered at the first location;  
 an average amount of power delivered at the first location;  
 an average temperature proximate a distal end of the ablation electrode;  
 a maximum temperature proximate a distal end of the ablation electrode;  
 an average contact force between the ablation electrode and the tissue; and  
 a maximum contact force between the ablation electrode and the tissue.

5. The system of claim 1, wherein the ECU is further configured to generate a first index responsive to a degree of electrical coupling between an ablation electrode and the tissue.

6. The system of claim 1, wherein the ECU is further configured to generate, at the first location, a first visual characteristic, wherein the first visual characteristic represents the at least one weighted factor indicative of delivery of ablation energy at the first location.

7. The system of claim 3, wherein the ECU is further configured to generate, at a second location, a second visual characteristic, wherein the second visual characteristic represents the at least one weighted factor indicative of delivery of ablation energy at the second location.

8. The system of claim 1, wherein the ECU is further configured to:

generate a second index indicative of a state of ablation at the second location;  
 generate a cumulative index responsive to the first index and the second index; and  
 generate, responsive to the cumulative index, a third visual characteristic corresponding to the first location and a fourth visual characteristic corresponding to the second location.

9. The system of claim 1, wherein the ECU is further configured to generate the index responsive to a degree of electrical coupling between an ablation electrode and the tissue.

10. The system of claim 8, wherein the first index is generated in response to a degree of electrical coupling between an ablation electrode and the tissue at the first location, and wherein the second index is generated in response to a degree of electrical coupling between the ablation electrode and the tissue at the second location.

\* \* \* \* \*

专利名称(译)	用于评估消融治疗的有效递送的系统和方法		
公开(公告)号	<a href="#">US10130419</a>	公开(公告)日	2018-11-20
申请号	US14/872208	申请日	2015-10-01
[标]申请(专利权)人(译)	ST Jude Medical公司心房颤动DIV IN		
申请(专利权)人(译)	ST.犹达医疗用品, 房颤划分,		
当前申请(专利权)人(译)	ST.犹达医疗用品, 房颤DIVISION, INC.		
[标]发明人	DENO D CURTIS MILLER STEPHAN P		
发明人	DENO, D. CURTIS MILLER, STEPHAN P.		
IPC分类号	A61B18/12 A61B5/00 A61B90/00 A61B18/14 A61B5/06 A61B18/00 A61N7/02 A61B5/053 A61B17/00 A61B18/02 A61B5/01		
CPC分类号	A61B18/1492 A61B5/4848 A61B5/6843 A61B5/6844 A61B5/6885 A61B5/743 A61B90/37 A61B5/068 A61N7/022 A61B5/01 A61B5/0538 A61B18/02 A61B2017/00044 A61B2017/00199 A61B2018/00351 A61B2018/00577 A61B2018/00642 A61B2218/002		
审查员(译)	福勒, DANIEL		
其他公开文献	US20160095651A1		
外部链接	<a href="#">Espacenet</a>		

摘要(译)

提供了一种用于评估消融疗法向身体组织的有效递送的系统和方法。生成组织的三维解剖图并与定义相应体积的图一起显示。产生对应于体积内的位置的指数，其中指数指示该位置处的消融治疗的状态。该指数可以源自一个或多个因素，例如消融电极存在于该位置的持续时间，所提供的能量的量，消融电极与该位置处的组织和温度之间的电耦合程度。然后响应于该指数改变对应于该位置的解剖图的一部分的视觉特征（例如，颜色强度）。

