



(19) **United States**

(12) **Patent Application Publication**  
**Ghosh**

(10) **Pub. No.: US 2019/0192023 A1**  
(43) **Pub. Date: Jun. 27, 2019**

- (54) **ECTOPIC BEAT-COMPENSATED ELECTRICAL HETEROGENEITY INFORMATION**
- (71) Applicant: **Medtronic, Inc.**, Minneapolis, MN (US)
- (72) Inventor: **Subham Ghosh**, Blaine, MN (US)
- (21) Appl. No.: **15/853,160**
- (22) Filed: **Dec. 22, 2017**

**Publication Classification**

- (51) **Int. Cl.**  
*A61B 5/04* (2006.01)  
*A61B 5/0408* (2006.01)

- A61B 5/00* (2006.01)
- A61N 1/365* (2006.01)
- (52) **U.S. Cl.**  
CPC ..... *A61B 5/04012* (2013.01); *A61B 5/04085* (2013.01); *A61N 1/36507* (2013.01); *A61B 5/7435* (2013.01); *A61B 5/686* (2013.01); *A61B 5/6823* (2013.01)

(57) **ABSTRACT**  
The exemplary systems and methods may be configured for use in the determination of ectopic beat-compensated electrical heterogeneity information. Electrical activity can be monitored by a plurality of external electrodes. Ectopic beat information can be detected. Ectopic beat-compensated electrical heterogeneity information can be generated based on the monitored electrical activity and the detected ectopic beat information.

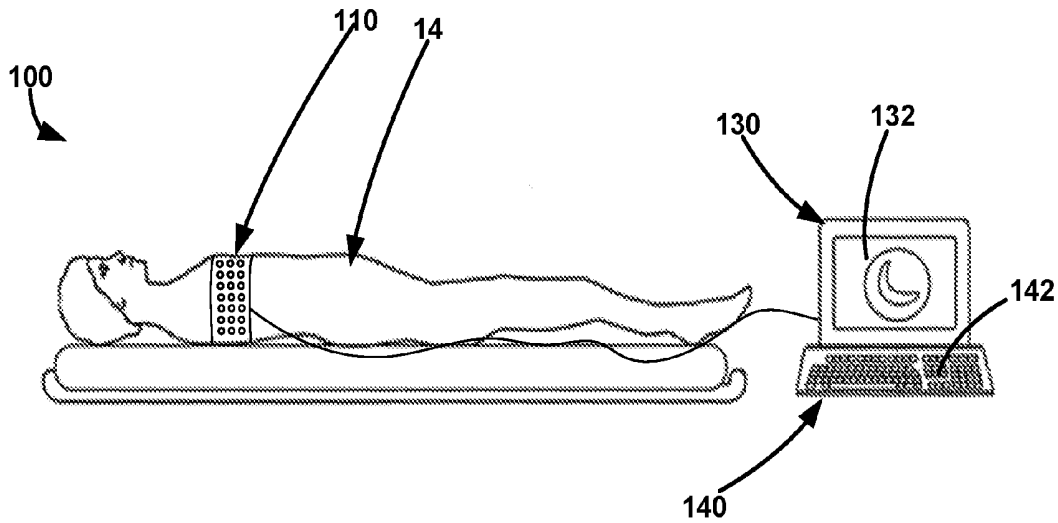

FIG. 1

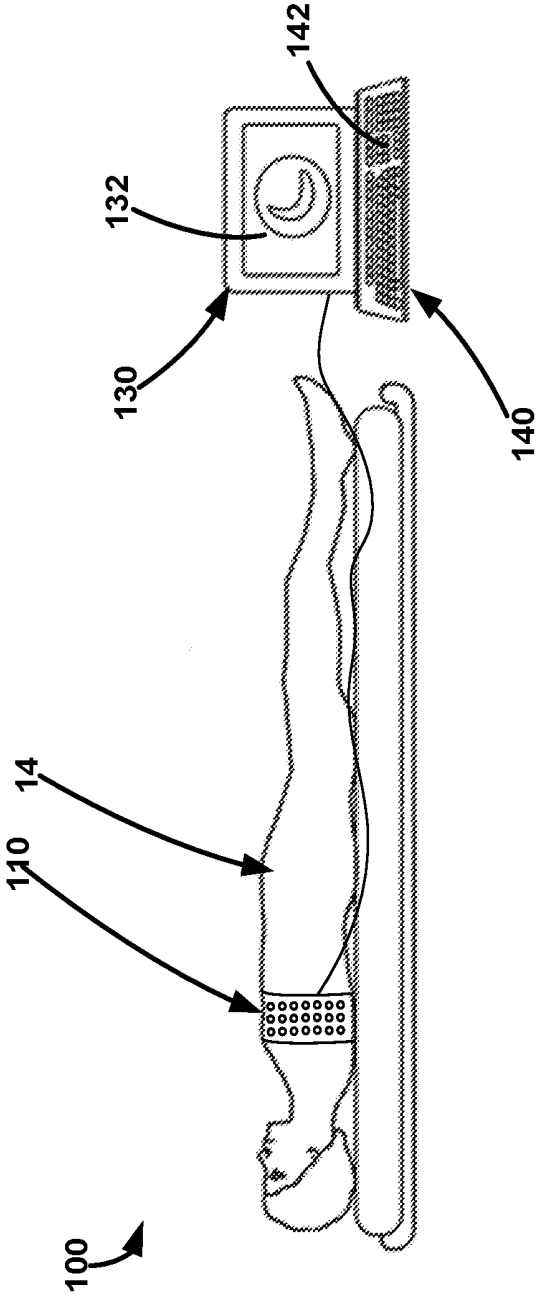

FIG. 2

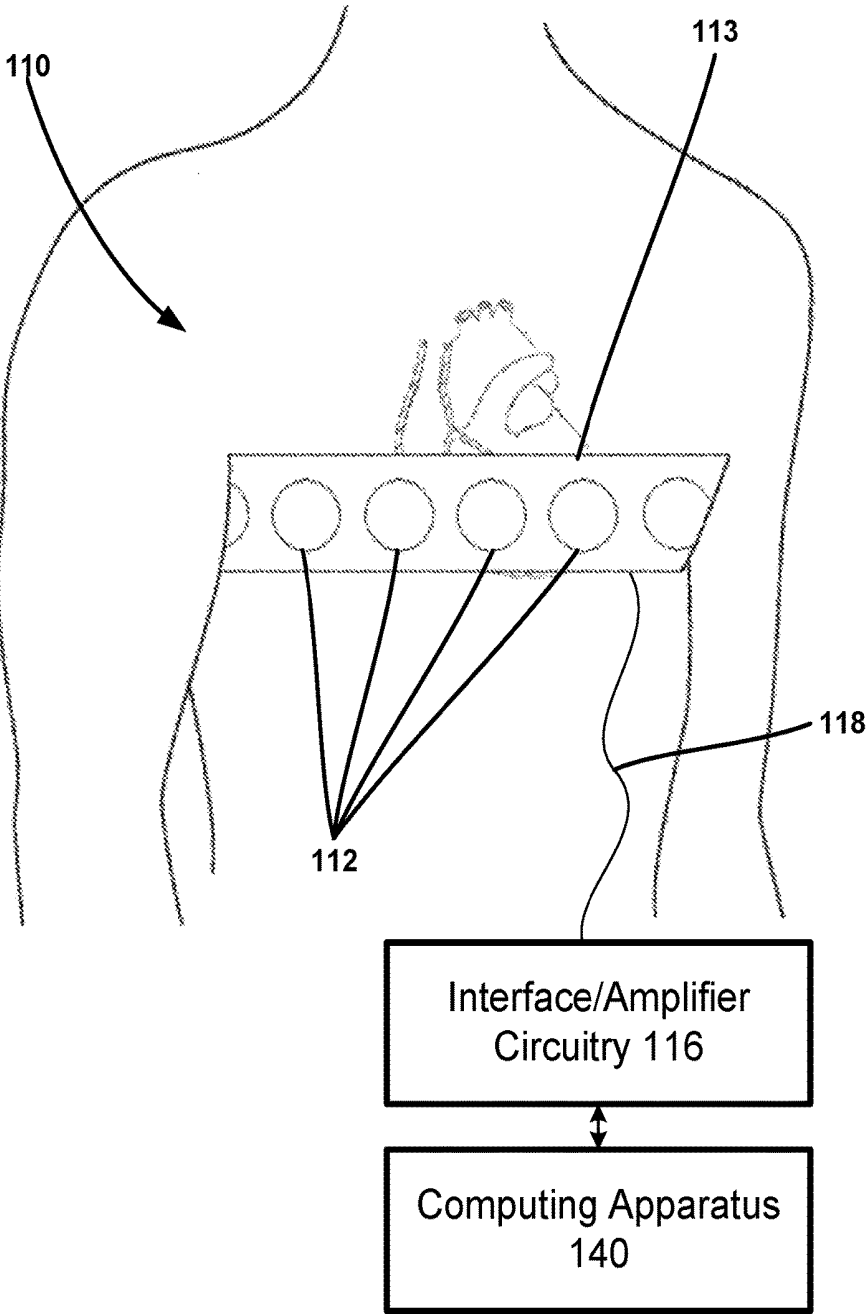
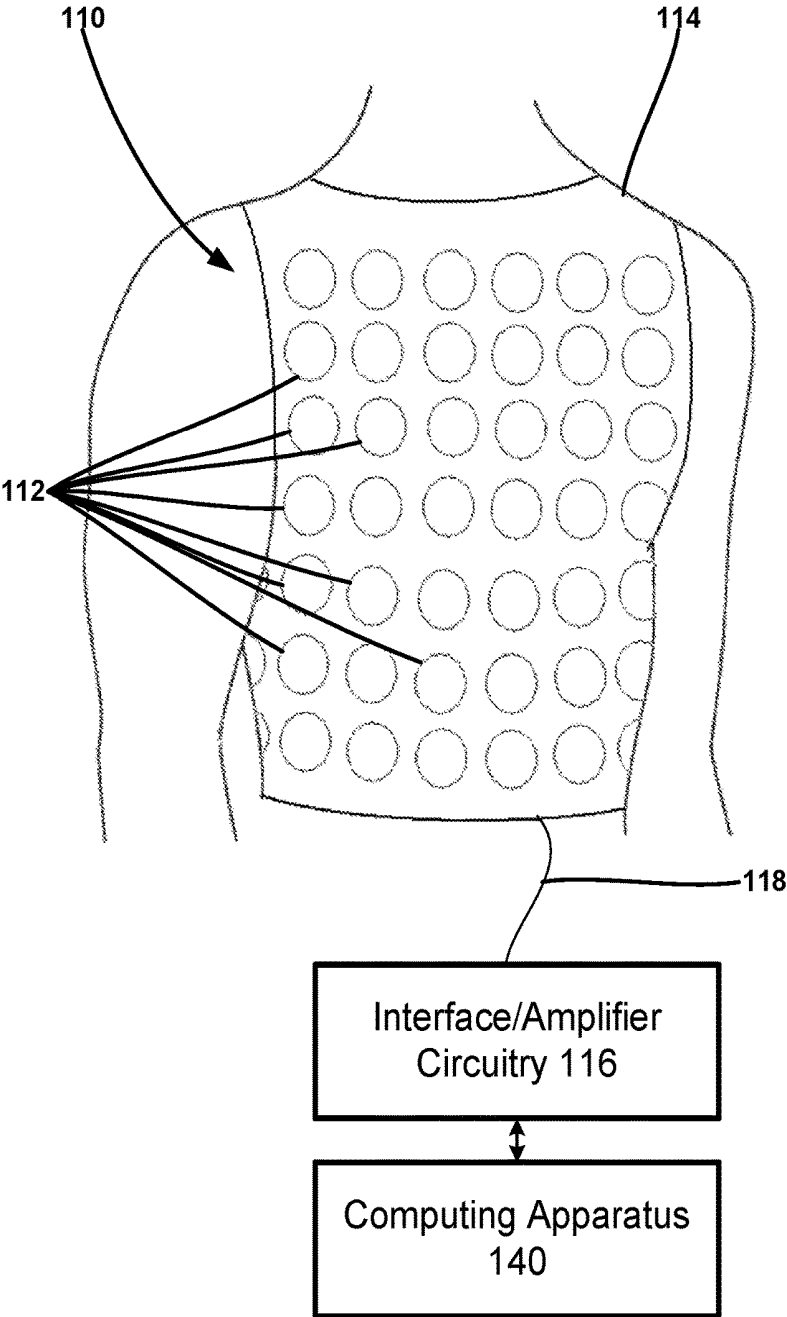
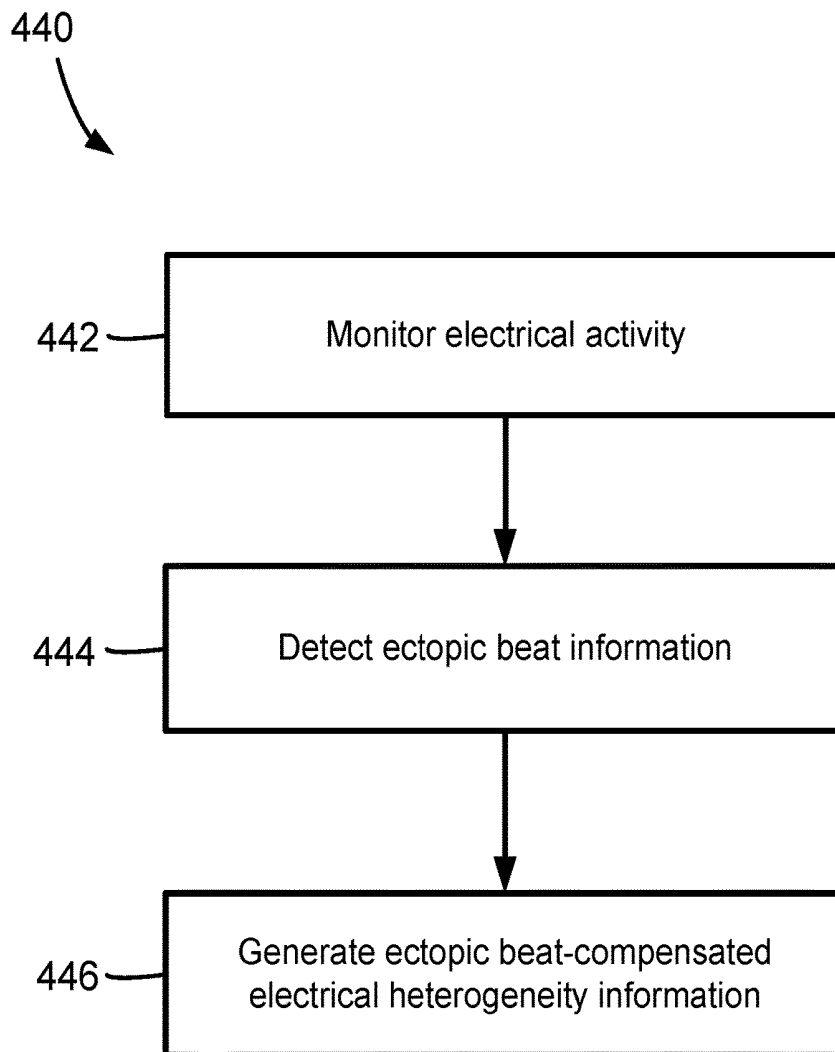
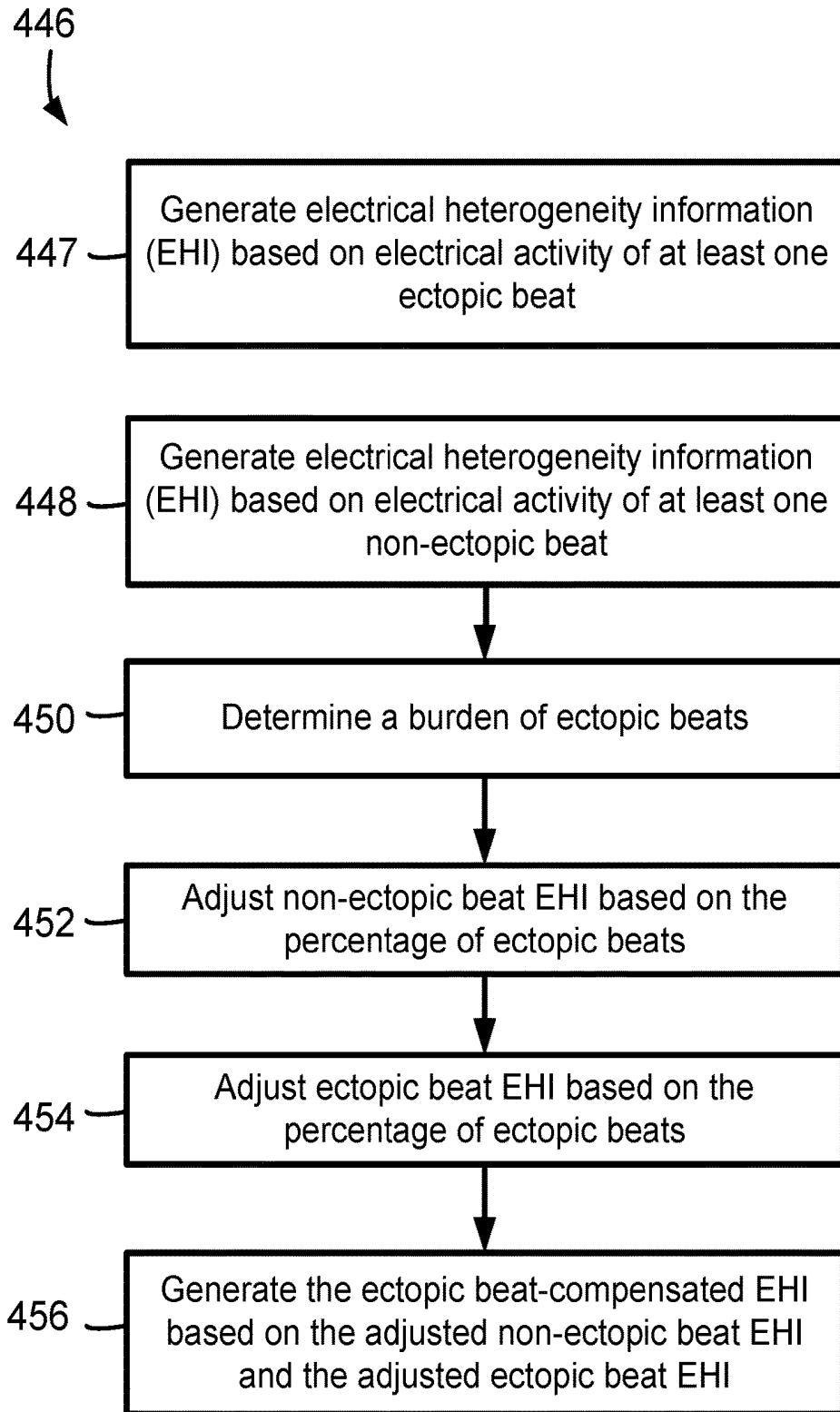

FIG. 3





**FIG. 4**



**FIG. 5**

FIG. 6

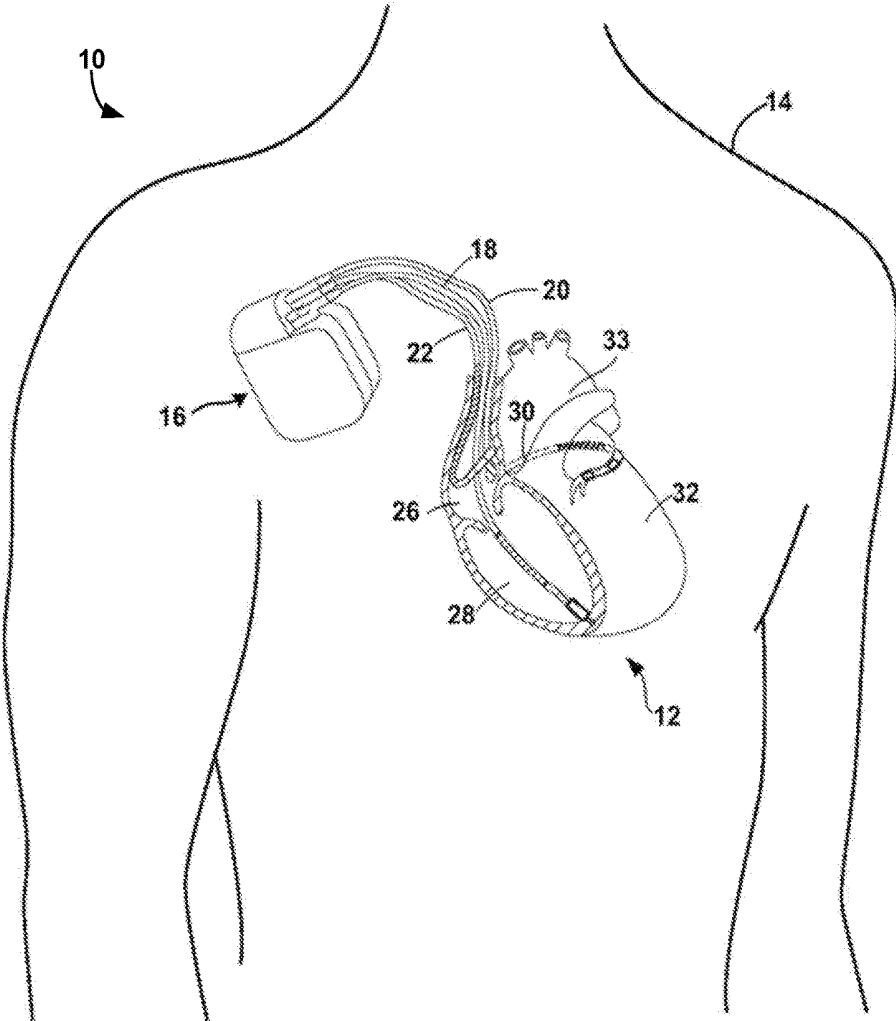

FIG. 7

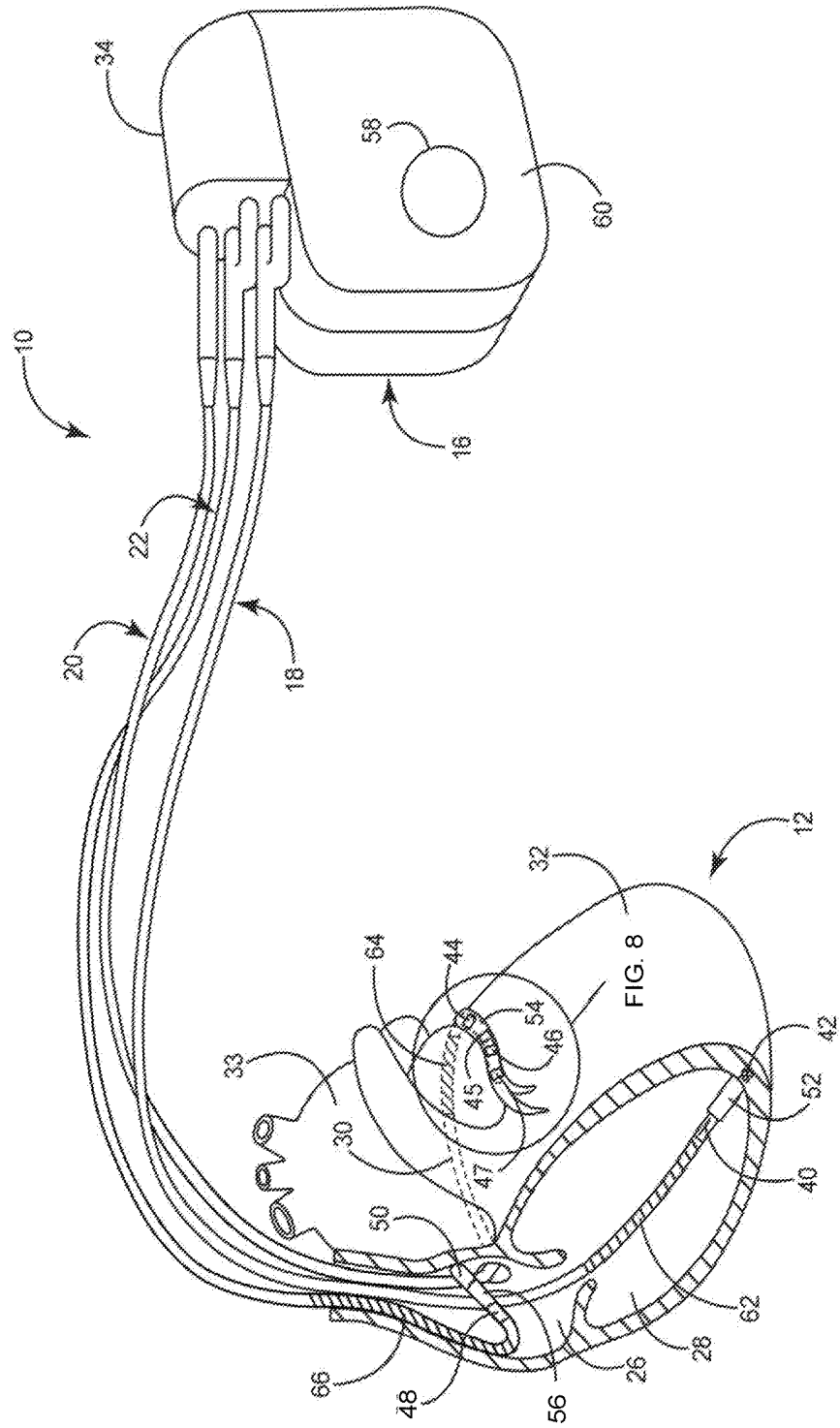

FIG. 8

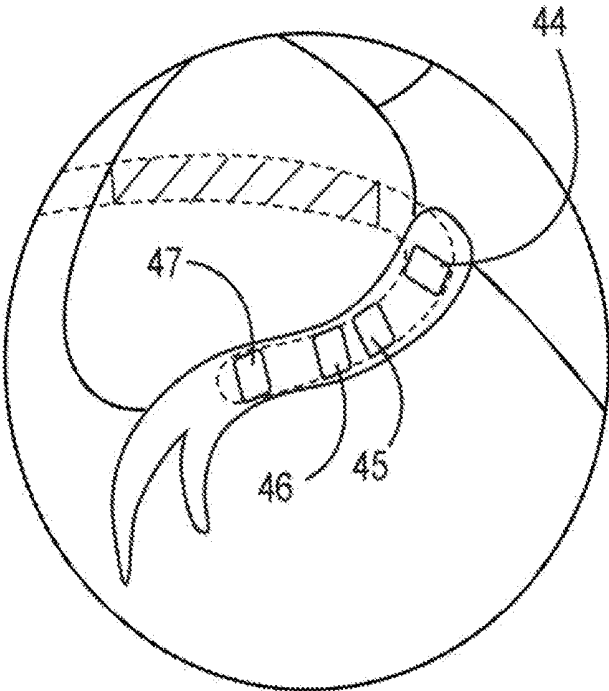

FIG. 9

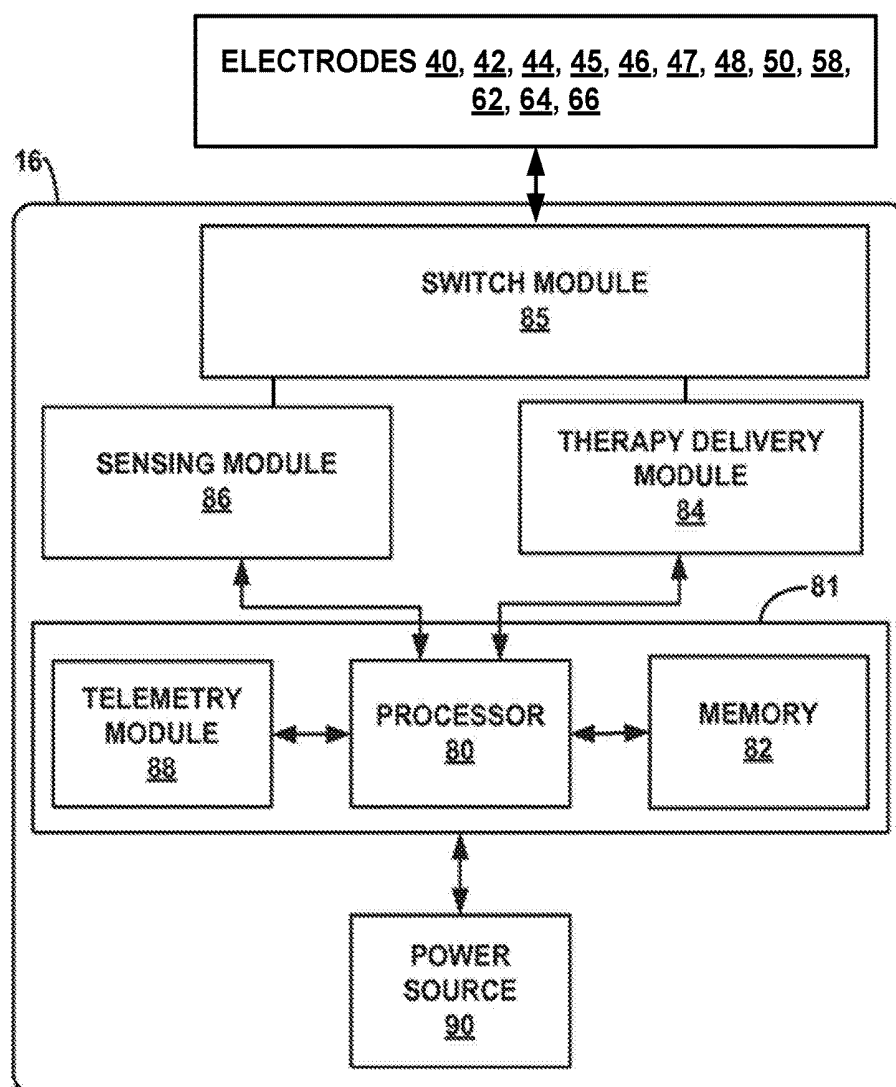
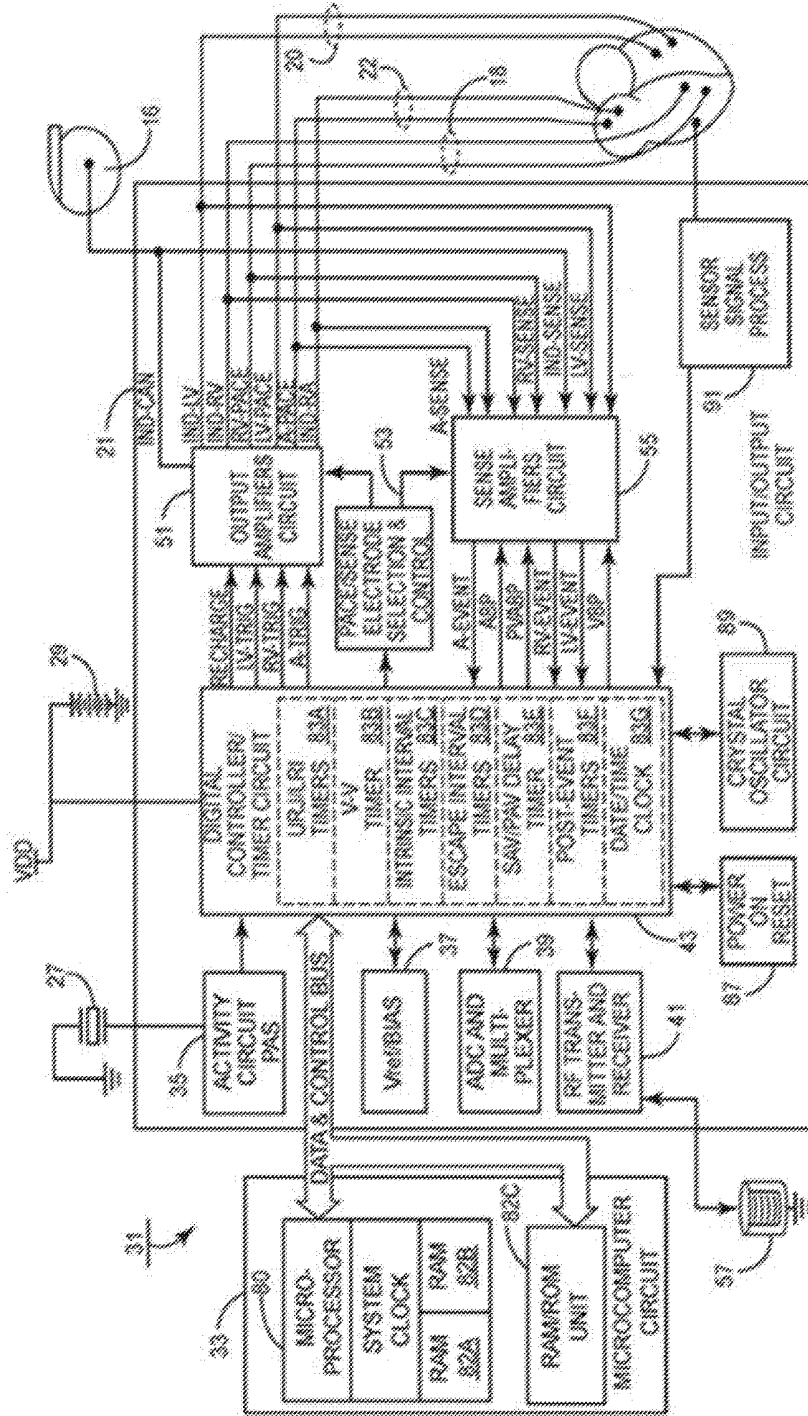

FIG. 10



## ECTOPIC BEAT-COMPENSATED ELECTRICAL HETEROGENEITY INFORMATION

**[0001]** The disclosure herein relates to systems and methods for use in the determination of ectopic beat-compensated electrical heterogeneity information from a plurality of cardiac signals.

### SUMMARY

**[0002]** The exemplary systems, methods, and interfaces described herein may be configured to assist a user (e.g., a physician) in evaluating a patient and/or evaluating cardiac therapy (e.g., cardiac therapy being performed on a patient during and/or after implantation of cardiac therapy apparatus). In one or more embodiments, the systems, methods, and interfaces may be described as being noninvasive. For example, in some embodiments, the systems, methods, and interfaces may not need, or include, implantable devices such as leads, probes, sensors, catheters, implantable electrodes, etc. to monitor, or acquire, a plurality of cardiac signals from tissue of the patient for use in evaluating the patient and/or cardiac therapy. Instead, the systems, methods, and interfaces may use electrical measurements taken noninvasively using, e.g., a plurality of external electrodes attached to the skin of a patient about the patient's torso.

**[0003]** In one or more embodiments, the systems, methods, and interfaces may use, or include, implantable devices such as leads, probes, implantable electrodes, etc. to monitor, or acquire, a plurality of cardiac signals from tissue of the patient for use in evaluating the patient and/or cardiac therapy. For example, the systems, methods, and interfaces may use electrical measurements taken using, e.g., a plurality of implantable electrodes either implanted long term or temporarily within a patient.

**[0004]** In at least one embodiment, electrical activity of a patient's heart can be monitored by a plurality of external electrodes. The monitored electrical activity can be used to detect ectopic beat information from the patient. The monitored electrical activity and the detected ectopic beat information can be used to generate ectopic beat-compensated electrical heterogeneity information to determine an effect that the ectopic beats have on the electrical activity of the patient's heart.

**[0005]** One exemplary system may include an electrode apparatus. The electrode apparatus can include a plurality of external electrodes to monitor electrical activity from tissue of a patient. The exemplary system may include a computing apparatus. The computing apparatus can include on or more processing circuitry. The computing apparatus can be coupled to the electrode apparatus. The computing apparatus can be configured to monitor electrical activity using the plurality of external electrodes. The computing apparatus can be further configured to detect ectopic beat information. The computing apparatus can be further configured to generate ectopic beat-compensated electrical heterogeneity information based on the monitored electrical activity and the detected ectopic beat information.

**[0006]** In at least one embodiment, an exemplary method can include monitoring electrical activity from tissue of a patient using a plurality of external electrodes. The exemplary method can further include detecting ectopic beat information. The method can further include generating ectopic beat-compensated electrical heterogeneity informa-

tion based on the monitored electrical activity and the detected ectopic beat information.

**[0007]** In at least one embodiment, an exemplary system can include an electrode apparatus that includes a plurality of external electrodes to monitor electrical activity from tissue of a patient. The exemplary system can include a computing apparatus. The computing apparatus can include processing circuitry and can be coupled to the electrode apparatus. The computing apparatus can be configured to monitor electrical activity using the plurality of external electrodes. The computing apparatus can be further configured to detect ectopic beat information, wherein the detected ectopic beat information comprises a percentage of ectopic beats of a plurality of beats over a selected period of time. The computing apparatus can be further configured to generate ectopic beat-compensated electrical heterogeneity information based on the monitored electrical activity and the detected ectopic beat information. The generation of the ectopic beat-compensated electrical heterogeneity information can be performed by adjusting, based on the percentage of ectopic beats, the non-ectopic beat electrical heterogeneity information which comprises a metric of non-ectopic electrical heterogeneity. The generation of the ectopic beat-compensated electrical heterogeneity information can be performed by adjusting, based on the percentage of ectopic beats, the ectopic beat electrical heterogeneity information which comprises a metric of ectopic electrical heterogeneity.

**[0008]** The above summary is not intended to describe each embodiment or every implementation of the present disclosure. A more complete understanding will become apparent and appreciated by referring to the following detailed description and claims taken in conjunction with the accompanying drawings.

### BRIEF DESCRIPTION OF THE DRAWINGS

**[0009]** FIG. 1 is a diagram of an exemplary system including electrode apparatus, display apparatus, and computing apparatus.

**[0010]** FIGS. 2-3 are diagrams of exemplary external electrode apparatus for measuring torso-surface potentials.

**[0011]** FIG. 4 is a block diagram of an exemplary method for generating ectopic beat-compensated electrical heterogeneity information.

**[0012]** FIG. 5 is a detailed block diagram of processing circuitry for use in generating ectopic beat-compensated electrical heterogeneity information.

**[0013]** FIG. 6 is a diagram of an exemplary system including an exemplary implantable medical device (IMD).

**[0014]** FIG. 7 is a diagram of the exemplary IMD of FIG. 6.

**[0015]** FIG. 8 is a diagram of an enlarged view of a distal end of the electrical lead disposed in the left ventricle of FIG. 7.

**[0016]** FIG. 9 is a block diagram of an exemplary IMD, e.g., of the systems of FIGS. 6-8.

**[0017]** FIG. 10 is another block diagram of an exemplary IMD (e.g., an implantable pulse generator) circuitry and associated leads employed in the systems of FIGS. 6-8.

### DETAILED DESCRIPTION OF EXEMPLARY EMBODIMENTS

**[0018]** In the following detailed description of illustrative embodiments, reference is made to the accompanying fig-

ures of the drawing which form a part hereof, and in which are shown, by way of illustration, specific embodiments which may be practiced. It is to be understood that other embodiments may be utilized and structural changes may be made without departing from (e.g., still falling within) the scope of the disclosure presented hereby.

**[0019]** Exemplary systems and methods shall be described with reference to FIGS. 1-10. It will be apparent to one skilled in the art that elements or processes from one embodiment may be used in combination with elements or processes of the other embodiments, and that the possible embodiments of such methods and systems using combinations of features set forth herein is not limited to the specific embodiments shown in the Figures and/or described herein. Further, it will be recognized that the embodiments described herein may include many elements that are not necessarily shown to scale. Still further, it will be recognized that timing of the processes and the size and shape of various elements herein may be modified but still fall within the scope of the present disclosure, although certain timings, one or more shapes and/or sizes, or types of elements, may be advantageous over others.

**[0020]** Systems, methods, and apparatuses are disclosed herein using non-invasive electrocardiographic mapping of electrical activation using an ECG belt to determine cardiac dyssynchrony associated with ectopic beat(s) and compare these ectopic beats to cardiac dyssynchrony of a native (e.g., intrinsic and in the absence of pacing) beat and one or more paced therapy beats, e.g., especially in patients with frequent ventricular ectopy. Ectopic beats of a heart can cause interference with implantable cardiac pacing therapies (e.g., such as cardiac resynchronization therapies).

**[0021]** An ectopic beat can be caused by a premature ventricular contraction (PVC). A PVC can refer to an event where the heartbeat is initiated by Purkinje fibers in the ventricles of the heart rather than by the sinoatrial node (which is the normal heartbeat initiator). The electrical events of the heart detected by the electrocardiogram (ECG) can allow a PVC to be distinguished from a normal heart beat. A PVC can sometimes be perceived as a "skipped beat" or felt as a palpitation in the chest. In a normal heartbeat, the ventricles contract after the atria has helped to fill them by contracting. In this way, the ventricles can pump a maximized amount of blood both to the lungs and to the rest of the body. In a PVC, the ventricles contract first and before the atria have optimally filled the ventricles with blood, causing an inefficiency in the circulation. A PVC can be a type of ectopic beat. An ectopic beat can refer to a disturbance of cardiac rhythm related to electrical conduction systems of the heart in which beats arise from fibers or groups of fibers outside the region in the heart muscle ordinarily responsible for impulse formation (i.e., outside the sinoatrial node).

**[0022]** In at least one embodiment, determinations of ectopic beats can be performed during left ventricular pacing (e.g., left ventricular pacing only) as well as biventricular pacing including different right ventricular-left ventricular (RV-LV) delays. This ectopic beat information can be used to evaluate risk of a developing heart failure and/or program cardiac device parameters (e.g., pacing mode LV vs. biventricular (BV) pacing or BV pacing with different ventricular-ventricular (VV) delays) to minimize dyssynchrony during pacing in patients with frequent ventricular ectopy. Ectopy can refer to a disturbance of cardiac rhythm fre-

quently related to electrical conduction systems of the heart, in which beats arise from fibers or groups of fibers outside the region in the heart muscle ordinarily responsible for impulse formation (i.e., the sinoatrial (SA) node).

**[0023]** Cardiac electrical activation times can be detected using unipolar electrocardiogram (ECG) recordings. Such electrical activation times may be measured and displayed, or conveyed, by a system which acquires the ECG signals and generates the metric of electrical activation times (e.g., depolarization) measured from various ECG locations in order to determine ectopic cardiac information prior to (in absence of), during, and subsequent to cardiac pacing therapy.

**[0024]** Various exemplary systems, methods, and interfaces may be configured to use electrode apparatus including external electrodes, display apparatus, and computing apparatus to noninvasively assist a user (e.g., a physician) in the evaluation of a patient's condition and/or cardiac therapy being performed on a patient. An exemplary system **100** including electrode apparatus **110**, display apparatus **130**, and computing apparatus **140** is depicted in FIG. 1.

**[0025]** The electrode apparatus **110** as shown includes a plurality of electrodes incorporated, or included, within a band wrapped around the chest, or torso, of a patient **14**. The electrode apparatus **110** is operatively coupled to the computing apparatus **140** (e.g., through one or wired electrical connections, wirelessly, etc.) to provide electrical signals from each of the electrodes to the computing apparatus **140** for analysis, evaluation, etc. Exemplary electrode apparatus may be described in U.S. Pat. No. 9,320,446 entitled "Bio-electric Sensor Device and Methods" and issued on Apr. 26, 2016, which is incorporated herein by reference in its entirety. Further, exemplary electrode apparatus **110** will be described in more detail in reference to FIGS. 2-3.

**[0026]** Although not described herein, the exemplary system **100** may further include imaging apparatus. The imaging apparatus may be any type of imaging apparatus configured to image, or provide images of, at least a portion of the patient in a noninvasive manner. For example, the imaging apparatus may not use any components or parts that may be located within the patient to provide images of the patient except noninvasive tools such as contrast solution. It is to be understood that the exemplary systems, methods, and interfaces described herein may further use imaging apparatus to provide noninvasive assistance to a user (e.g., a physician) to determine ectopic (or extrasystolic) beat information to select a pacing parameter, a pacing electrode, or pacing vector proximate the patient's heart in conjunction with the evaluation of cardiac therapy.

**[0027]** For example, the exemplary systems, methods, and interfaces may provide image guided navigation that may be used to navigate leads including electrodes, leadless electrodes, wireless electrodes, catheters, etc., within the patient's body while also providing noninvasive cardiac therapy evaluation including determining whether a His bundle pacing parameter is acceptable or determining whether one or more selected parameters are acceptable, such as selected location information (e.g., location information for the electrodes to target the His bundle). Exemplary systems and methods that use imaging apparatus and/or electrode apparatus may be described in U.S. Patent Publication No. 2014/0371832 filed on Jun. 12, 2013 and entitled "Implantable Electrode Location Selection," U.S. Patent Publication No. 2014/0371833 filed on Jun. 12, 2013

and entitled “Implantable Electrode Location Selection,” U.S. Patent Publication No. 2014/0323892 filed on Mar. 27, 2014 and entitled “Systems, Methods, and Interfaces for Identifying Effective Electrodes,” U.S. Patent Publication No. 2014/0323882 filed on Mar. 27, 2014 and entitled “Systems, Methods, and Interfaces for Identifying Optical Electrical Vectors,” each of which is incorporated herein by reference in its entirety.

**[0028]** Exemplary imaging apparatus may be configured to capture x-ray images and/or any other alternative imaging modality. For example, the imaging apparatus may be configured to capture images, or image data, using isocentric fluoroscopy, bi-plane fluoroscopy, ultrasound, computed tomography (CT), multi-slice computed tomography (MSCT), magnetic resonance imaging (MRI), high frequency ultrasound (HIFU), optical coherence tomography (OCT), intra-vascular ultrasound (IVUS), two dimensional (2D) ultrasound, three dimensional (3D) ultrasound, four dimensional (4D) ultrasound, intraoperative CT, intraoperative MRI, etc. Further, it is to be understood that the imaging apparatus may be configured to capture a plurality of consecutive images (e.g., continuously) to provide video frame data. In other words, a plurality of images taken over time using the imaging apparatus may provide video frame, or motion picture, data. Additionally, the images may also be obtained and displayed in two, three, or four dimensions. In more advanced forms, four-dimensional surface rendering of the heart or other regions of the body may also be achieved by incorporating heart data or other soft tissue data from a map or from pre-operative image data captured by MRI, CT, or echocardiography modalities. Image datasets from hybrid modalities, such as positron emission tomography (PET) combined with CT, or single photon emission computer tomography (SPECT) combined with CT, could also provide functional image data superimposed onto anatomical data, e.g., to be used to navigate treatment apparatus proximate target locations within the heart or other areas of interest.

**[0029]** Systems and/or imaging apparatus that may be used in conjunction with the exemplary systems and method described herein are described in U.S. Pat. App. Pub. No. 2005/0008210 to Evron et al. published on Jan. 13, 2005, U.S. Pat. App. Pub. No. 2006/0074285 to Zarkh et al. published on Apr. 6, 2006, U.S. Pat. App. Pub. No. 2011/0112398 to Zarkh et al. published on May 12, 2011, U.S. Pat. App. Pub. No. 2013/0116739 to Brada et al. published on May 9, 2013, U.S. Pat. No. 6,980,675 to Evron et al. issued on Dec. 27, 2005, U.S. Pat. No. 7,286,866 to Okerlund et al. issued on Oct. 23, 2007, U.S. Pat. No. 7,308,297 to Reddy et al. issued on Dec. 11, 2011, U.S. Pat. No. 7,308,299 to Burrell et al. issued on Dec. 11, 2011, U.S. Pat. No. 7,321,677 to Evron et al. issued on Jan. 22, 2008, U.S. Pat. No. 7,346,381 to Okerlund et al. issued on Mar. 18, 2008, U.S. Pat. No. 7,454,248 to Burrell et al. issued on Nov. 18, 2008, U.S. Pat. No. 7,499,743 to Vass et al. issued on Mar. 3, 2009, U.S. Pat. No. 7,565,190 to Okerlund et al. issued on Jul. 21, 2009, U.S. Pat. No. 7,587,074 to Zarkh et al. issued on Sep. 8, 2009, U.S. Pat. No. 7,599,730 to Hunter et al. issued on Oct. 6, 2009, U.S. Pat. No. 7,613,500 to Vass et al. issued on Nov. 3, 2009, U.S. Pat. No. 7,742,629 to Zarkh et al. issued on Jun. 22, 2010, U.S. Pat. No. 7,747,047 to Okerlund et al. issued on Jun. 29, 2010, U.S. Pat. No. 7,778,685 to Evron et al. issued on Aug. 17, 2010, U.S. Pat. No. 7,778,686 to Vass et al. issued on Aug. 17, 2010, U.S.

Pat. No. 7,813,785 to Okerlund et al. issued on Oct. 12, 2010, U.S. Pat. No. 7,996,063 to Vass et al. issued on Aug. 9, 2011, U.S. Pat. No. 8,060,185 to Hunter et al. issued on Nov. 15, 2011, and U.S. Pat. No. 8,401,616 to Verard et al. issued on Mar. 19, 2013, each of which is incorporated herein by reference in its entirety.

**[0030]** The display apparatus **130** and the computing apparatus **140** may be configured to display and analyze data such as, e.g., electrical signals (e.g., electrocardiogram data), cardiac information representative of at least one of mechanical cardiac functionality and electrical cardiac functionality, etc. Cardiac information may include, e.g., electrical heterogeneity information or electrical dyssynchrony information, surrogate electrical activation information or data, etc. that is generated using electrical signals gathered, monitored, or collected, using the electrode apparatus **110**. In at least one embodiment, the computing apparatus **140** may be a server, a personal computer, or a tablet computer. The computing apparatus **140** may be configured to receive input from input apparatus **142** and transmit output to the display apparatus **130**. Further, the computing apparatus **140** may include data storage that may allow for access to processing programs or routines and/or one or more other types of data, e.g., for driving a graphical user interface configured to noninvasively assist a user in evaluating a pacing parameter (e.g., pacing mode LV vs. BC pacing or BC pacing with different VV delays), a pacing vector, and/or a pacing location (e.g., the location of an implantable electrode used for pacing, the location of pacing therapy delivered by a particular pacing vector, etc.).

**[0031]** The computing apparatus **140** may be operatively coupled to the input apparatus **142** and the display apparatus **130** to, e.g., transmit data to and from each of the input apparatus **142** and the display apparatus **130**. For example, the computing apparatus **140** may be electrically coupled to each of the input apparatus **142** and the display apparatus **130** using, e.g., analog electrical connections, digital electrical connections, wireless connections, bus-based connections, network-based connections, internet-based connections, etc. As described further herein, a user may provide input to the input apparatus **142** to manipulate, or modify, one or more graphical depictions displayed on the display apparatus **130** and to view and/or select one or more pieces of information related to the cardiac therapy.

**[0032]** Although as depicted the input apparatus **142** is a keyboard, it is to be understood that the input apparatus **142** may include any apparatus capable of providing input to the computing apparatus **140** to perform the functionality, methods, and/or logic described herein. For example, the input apparatus **142** may include a mouse, a trackball, a touchscreen (e.g., capacitive touchscreen, a resistive touchscreen, a multi-touch touchscreen, etc.), etc. Likewise, the display apparatus **130** may include any apparatus capable of displaying information to a user, such as a graphical user interface **132** including cardiac information, textual instructions, graphical depictions of electrical activation information, graphical depictions of anatomy of a human heart, images or graphical depictions of the patient's heart, graphical depictions of locations of one or more electrodes, graphical depictions of a human torso, images or graphical depictions of the patient's torso, graphical depictions or actual images of implanted electrodes and/or leads, etc. Further, the

display apparatus **130** may include a liquid crystal display, an organic light-emitting diode screen, a touchscreen, a cathode ray tube display, etc.

**[0033]** The processing programs or routines stored and/or executed by the computing apparatus **140** may include programs or routines for computational mathematics, matrix mathematics, dispersion determinations (e.g. standard deviations, variances, ranges, interquartile ranges, mean absolute differences, average absolute deviations, etc.), filtering algorithms, maximum value determinations, minimum value determinations, threshold determinations, moving windowing algorithms, decomposition algorithms, compression algorithms (e.g., data compression algorithms), calibration algorithms, image construction algorithms, signal processing algorithms (e.g., various filtering algorithms, Fourier transforms, fast Fourier transforms, etc.), standardization algorithms, comparison algorithms, vector mathematics, or any other processing required to implement one or more exemplary methods and/or processes described herein. Data stored and/or used by the computing apparatus **140** may include, for example, electrical signal/waveform data from the electrode apparatus **110**, dispersions signals, windowed dispersions signals, parts or portions of various signals, electrical activation times from the electrode apparatus **110**, graphics (e.g., graphical elements, icons, buttons, windows, dialogs, pull-down menus, graphic areas, graphic regions, 3D graphics, etc.), graphical user interfaces, results from one or more processing programs or routines employed according to the disclosure herein (e.g., electrical signals, cardiac information, etc.), or any other data that may be necessary for carrying out the one and/or more processes or methods described herein.

**[0034]** In one or more embodiments, the exemplary systems, methods, and interfaces may be implemented using one or more computer programs executed on programmable computers, such as computers that include, for example, processing capabilities, data storage (e.g., volatile or non-volatile memory and/or storage elements), input devices, and output devices. Program code and/or logic described herein may be applied to input data to perform functionality described herein and generate desired output information. The output information may be applied as input to one or more other devices and/or methods as described herein or as would be applied in a known fashion.

**[0035]** The one or more programs used to implement the systems, methods, and/or interfaces described herein may be provided using any programmable language, e.g., a high level procedural and/or object orientated programming language that is suitable for communicating with a computer system. Any such programs may, for example, be stored on any suitable device, e.g., a storage media, that is readable by a general or special purpose program running on a computer system (e.g., including processing apparatus) for configuring and operating the computer system when the suitable device is read for performing the procedures described herein. In other words, at least in one embodiment, the exemplary systems, methods, and/or interfaces may be implemented using a computer readable storage medium, configured with a computer program, where the storage medium so configured causes the computer to operate in a specific and predefined manner to perform functions described herein. Further, in at least one embodiment, the exemplary systems, methods, and/or interfaces may be described as being implemented by logic (e.g., object code) encoded in one or more

non-transitory media that includes code for execution and, when executed by a processor, is operable to perform operations such as the methods, processes, and/or functionality described herein.

**[0036]** The computing apparatus **140** may be, for example, any fixed or mobile computer system (e.g., a controller, a microcontroller, a personal computer, minicomputer, tablet computer, etc.) and may be generally described as including processing circuitry. The exact configuration of the computing apparatus **140** is not limiting, and essentially any device capable of providing suitable computing capabilities and control capabilities (e.g., graphics processing, etc.) may be used. As described herein, a digital file may be any medium (e.g., volatile or non-volatile memory, a CD-ROM, a punch card, magnetic recordable medium such as a disk or tape, etc.) containing digital bits (e.g., encoded in binary, trinary, etc.) that may be readable and/or writeable by computing apparatus **140** described herein. Also, as described herein, a file in user-readable format may be any representation of data (e.g., ASCII text, binary numbers, hexadecimal numbers, decimal numbers, graphically, etc.) presentable on any medium (e.g., paper, a display, etc.) readable and/or understandable by a user.

**[0037]** In view of the above, it will be readily apparent that the functionality as described in one or more embodiments according to the present disclosure may be implemented in any manner as would be known to one skilled in the art. As such, the computer language, the computer system, or any other software/hardware which is to be used to implement the processes described herein shall not be limiting on the scope of the systems, processes or programs (e.g., the functionality provided by such systems, processes or programs) described herein.

**[0038]** Electrical activation times of the patient's heart may be useful to evaluate a patient's cardiac condition and/or cardiac therapy being delivered to a patient. Surrogate electrical activation information or data of one or more regions of a patient's heart may be monitored, or determined, using electrode apparatus **110** as shown in FIG. 1 and in FIG. 2-3. The exemplary electrode apparatus **110** may be configured to measure body-surface potentials of a patient **14** and, more particularly, torso-surface potentials of a patient **14**. As shown in FIG. 2, the exemplary electrode apparatus **110** may include a set, or array, of electrodes **112**, a strap **113**, and interface/amplifier circuitry **116**. The electrodes **112** may be attached, or coupled, to the strap **113** and the strap **113** may be configured to be wrapped around the torso of a patient **14** such that the electrodes **112** surround the patient's heart. As further illustrated, the electrodes **112** may be positioned around the circumference of a patient **14**, including the posterior, lateral, posterolateral, anterolateral, and anterior locations of the torso of a patient **14**.

**[0039]** Further, the electrodes **112** may be electrically connected to interface/amplifier circuitry **116** via wired connection **118**. The interface/amplifier circuitry **116** may be configured to amplify the signals from the electrodes **112** and provide the signals to the computing apparatus **140**. Other exemplary systems may use a wireless connection to transmit the signals sensed by electrodes **112** to the interface/amplifier circuitry **116** and, in turn, the computing apparatus **140**, e.g., as channels of data. For example, the interface/amplifier circuitry **116** may be electrically coupled to each of the computing apparatus **140** and the display apparatus **130** using, e.g., analog electrical connections,

digital electrical connections, wireless connections, bus-based connections, network-based connections, internet-based connections, etc.

[0040] Although in the example of FIG. 2 the electrode apparatus 110 includes a strap 113, in other examples any of a variety of mechanisms, e.g., tape or adhesives, may be employed to aid in the spacing and placement of electrodes 112. In some examples, the strap 113 may include an elastic band, strip of tape, or cloth. In other examples, the electrodes 112 may be placed individually on the torso of a patient 14. Further, in other examples, electrodes 112 (e.g., arranged in an array) may be part of, or located within, patches, vests, and/or other manners of securing the electrodes 112 to the torso of the patient 14.

[0041] The electrodes 112 may be configured to surround the heart of the patient 14 and record, or monitor, the electrical signals associated with the depolarization and repolarization of the heart after the signals have propagated through the torso of a patient 14. Each of the electrodes 112 may be used in a unipolar configuration to sense the torso-surface potentials that reflect the cardiac signals. The interface/amplifier circuitry 116 may also be coupled to a return or indifferent electrode (not shown) that may be used in combination with each electrode 112 for unipolar sensing. In some examples, there may be about 12 to about 50 electrodes 112 spatially distributed around the torso of patient. Other configurations may have more or fewer electrodes 112.

[0042] The computing apparatus 140 may record and analyze the electrical activity (e.g., torso-surface potential signals) sensed by electrodes 112 and amplified/conditioned by the interface/amplifier circuitry 116. The computing apparatus 140 may be configured to analyze the signals from the electrodes 112 to provide as anterior and posterior electrode signals and surrogate cardiac electrical activation times, e.g., representative of actual, or local, electrical activation times of one or more regions of the patient's heart as will be further described herein. Further, the electrical signals measured at the left anterior surface location of a patient's torso may be representative, or surrogates, of electrical signals of the left anterior left ventricle region of the patient's heart, electrical signals measured at the left lateral surface location of a patient's torso may be representative, or surrogates, of electrical signals of the left lateral left ventricle region of the patient's heart, electrical signals measured at the left posterolateral surface location of a patient's torso may be representative, or surrogates, of electrical signals of the posterolateral left ventricle region of the patient's heart, and electrical signals measured at the posterior surface location of a patient's torso may be representative, or surrogates, of electrical signals of the posterior left ventricle region of the patient's heart. In one or more embodiments, measurement of activation times can be performed by measuring the period of time between an onset of cardiac depolarization (e.g., onset of QRS complex) and an appropriate fiducial point such as, e.g., a peak value, a minimum value, a minimum slope, a maximum slope, a zero crossing, a threshold crossing, etc.

[0043] Additionally, the computing apparatus 140 may be configured to provide graphical user interfaces depicting the surrogate electrical activation times obtained using the electrode apparatus 110. Exemplary systems, methods, and/or interfaces may noninvasively use the electrical information

collected using the electrode apparatus 110 to evaluate a patient's cardiac condition and/or cardiac therapy being delivered to the patient.

[0044] FIG. 3 illustrates another exemplary electrode apparatus 110 that includes a plurality of electrodes 112 configured to surround the heart of the patient 14 and record, or monitor, the electrical signals associated with the depolarization and repolarization of the heart after the signals have propagated through the torso of the patient 14. The electrode apparatus 110 may include a vest 114 upon which the plurality of electrodes 112 may be attached, or to which the electrodes 112 may be coupled. In at least one embodiment, the plurality, or array, of electrodes 112 may be used to collect electrical information such as, e.g., surrogate electrical activation times. Similar to the electrode apparatus 110 of FIG. 2, the electrode apparatus 110 of FIG. 3 may include interface/amplifier circuitry 116 electrically coupled to each of the electrodes 112 through a wired connection 118 and be configured to transmit signals from the electrodes 112 to computing apparatus 140. As illustrated, the electrodes 112 may be distributed over the torso of a patient 14, including, for example, the anterior, lateral, posterolateral, anterolateral, and posterior surfaces of the torso of the patient 14.

[0045] The vest 114 may be formed of fabric with the electrodes 112 attached to the fabric. The vest 114 may be configured to maintain the position and spacing of electrodes 112 on the torso of the patient 14. Further, the vest 114 may be marked to assist in determining the location of the electrodes 112 on the surface of the torso of the patient 14. In some examples, there may be about 25 to about 256 electrodes 112 distributed around the torso of the patient 14, though other configurations may have more or fewer electrodes 112.

[0046] As described herein, the electrode apparatus 110 may be configured to measure electrical information (e.g., electrical signals) representing different regions of a patient's heart. For example, activation times of different regions of a patient's heart can be approximated from surface electrocardiogram (ECG) activation times measured using surface electrodes in proximity to surface areas corresponding to the different regions of the patient's heart.

[0047] The exemplary systems, methods, and interfaces may be used to provide noninvasive assistance to a user in the evaluation of a patient's cardiac health or status, and/or the valuation of cardiac therapy (e.g., cardiac therapy being presently-delivered to a patient during implantation or after implantation). Further, the exemplary systems, methods, and interfaces may be used to assist a user in the configuration of the cardiac therapy being delivered to a patient.

[0048] FIG. 4 is a block diagram of an exemplary method 440 for mapping of ectopic beats. The method 440 can include monitoring electrical activity 442. The monitoring of the electrical activity 442 can include monitoring the electrical activity using a plurality of external electrodes, such as those described in association with FIGS. 1-3. The plurality of external electrodes can include surface electrodes positioned in an array and configured to be located proximate skin of a torso of the patient. The monitoring can be for a selected period of time. As an example, monitoring can occur for a half day (12 hours), a full day (24 hours), a week, a month, etc. As an example, monitoring can occur between minutes 0 and 30 of a selected hour, minutes 5 and 50 of a selected hour, etc. As an example, monitoring can

occur for a particular number of beats or until a particular threshold number of beats are monitored, for a particular threshold number of a particular type of beats monitored, etc. The monitoring can include monitoring a plurality of healthy cardiac beats. The monitoring can include monitoring at least one ectopic beat during the time period. An ectopic beat can refer to a beat that is out of synchrony with other beats during that time period. The monitoring can include monitoring in the absence of pacing therapy, e.g., during a period of time when pacing is not performed (referred to as intrinsic monitoring or monitoring of intrinsic beats). The monitoring can include monitoring during a pacing therapy. The monitoring can include detecting at least one ectopic beat while monitoring during pacing therapy.

**[0049]** In at least one example, the monitoring of electrical activity can include monitoring for cardiac dyssynchrony performed over a period of 15-30 seconds on a beat by beat basis to account for variations due to frequent ectopic beats. This can be performed during non-pacing (e.g., in the absence of pacing) for at least one non-ectopic beat and during at least one ectopic beat, and during a beat occurring during pacing therapy. In response to more than one type of ectopic morphology, the monitoring can be performed during at least a number of ectopic beats as there are morphologies of ectopic beats in order to average the electrical heterogeneity of the different ectopic beats with different morphologies.

**[0050]** Electrical heterogeneity information (EHI) can be determined for at least one beat during non-pacing. That is, EHI can be determined for a beat that is non-ectopic and without pacing therapy. EHI can be determined for at least one ectopic beat. In the case of ectopic beats with more than one morphology, EHI for additional ectopic beats can be determined and an average of the ectopic beats representing each of the morphologies can be determined. EHI can be determined for at least one beat during pacing therapy.

**[0051]** In at least one embodiment, the electrical heterogeneity information described above can be used to determine a change and/or differences in electrical heterogeneity. An exemplary metric of electrical heterogeneity can include a standard deviation of activation times (SDAT) determined at a plurality of external electrodes during the depolarization (QRS) complex corresponding to a particular rhythm. As an example, a change in electrical heterogeneity (e.g., a change in SDAT in this example) due to pacing therapy can be determined by the following formula:

$$\Delta SDAT = \frac{SDAT_{intrinsic} - SDAT_{pacing}}{SDAT_{intrinsic}}$$

That is, the result of subtracting  $SDAT_{pacing}$  from  $SDAT_{intrinsic}$  is divided by  $SDAT_{intrinsic}$ , resulting in the  $\Delta SDAT$  due to pacing. In one embodiment, a percent change from intrinsic electrical heterogeneity to pacing electrical heterogeneity can indicate whether pacing is effective compared to intrinsic cardiac behavior or whether pacing should be modified in light of a percentage difference reflecting the degree of improvement in synchronization not being adequate when compared to a certain threshold (e.g., 10%), etc. This determination of a difference in electrical heterogeneity can be used with the following method **440** to

determine an affect pacing has on intrinsic cardiac behavior and whether the pacing therapy is effective and/or acceptable.

**[0052]** The method **440** can include detecting ectopic beat information **444** during intrinsic monitoring and/or during pacing therapy monitoring. Detection of ectopic beat information **444** can include detecting ectopic beats and determining ectopic beat information. In at least one example, an implantable medical device (IMD) can include a premature ventricular contraction (PVC) counter. The PVC counter can count a number of ectopic beats during a particular time while normal pacing of a patient is occurring. The PVC counter can indicate a percentage of beats during a period of pacing and monitoring using the 1 MB that are ectopic. Each PVC event, in at least one example, can be detected by determining that a morphology of a particular beat is different than a morphology that would be expected during normal pacing of the patient. During an acute monitoring of the ectopic beat, a ventricular paced beat would have a different morphology than a PVC beat and would be indicated as a sense beat outside the normal paced beats. In order to determine these morphologies, a period of a higher rate of pacing than would normally occur for the patient can be performed in order to determine an expected morphology of a paced beat. This expected morphology would be used to compare to each beat, both paced and non-paced, in order to determine whether it is a PVC beat, and therefore, whether to add it as an ectopic beat by the PVC counter in the 1 MB. As an overall PVC burden is used to determine what effect the PVC beats are having on the patient, the 1 MB PVC counter is an effective way of measuring the PVC burden over a period of time. Each session, or period of time, that the PVC counter is measuring can be reset at a particular point.

**[0053]** In at least one example, an ectopic beat can be determined using an ECG belt. A morphology of each beat while being sensed by the ECG belt can indicate which beats are ectopic. As an example, a greater rate of pacing can be performed on a patient to determine an expected morphology of a paced beat and each beat can be compared to this expected morphology. A beat with a different morphology than the expected morphology can be determined to be an ectopic beat. The morphology can include a particular characteristic of a QRS wave of a beat, among other characteristics.

**[0054]** Thus, the ectopic beat information may be provided using and/or detect by at least one of an implantable cardiac device, a subcutaneous cardiac monitor, an external cardiac monitor, and a plurality of external electrodes.

**[0055]** The ectopic beat information can include a metric from a comparison of ectopic beats to another number of beats. As an example, the metric can compare a number of ectopic beats to a total number of beats during a period of time. The metric can compare a number of ectopic beats to a number of non-ectopic beats during a period of time. The metric can compare an amount of time that ectopic beats occurred versus an amount of time that healthy, non-ectopic beats occurred. Further, the metric can indicate a ratio of ectopic beats to total beats or ectopic beats to non-ectopic beats, etc. As an example, if during a selected period of time there were 100 ectopic beats detected and 1,000 non-ectopic beats detected, a determination that there were 10% ectopic beats to 90% non-ectopic beats can be made. Further, in another example, if during a selected period of time there

were 1,000 beats that were paced and 100 ectopic beats (e.g., PVC related beats), a determination that there were 90% paced beats and 10% ectopic beats can be made. The comparison of paced beats to ectopic beats can be referred to as the burden for each corresponding type of beat. As in this example above, the pacing burden would be 90% and the ectopic burden would be 10%. In at least one embodiment, this comparison can be made for monitoring in the absence of pacing or for monitoring during pacing therapy. Detecting ectopic beat information 444 can include detecting more than one ectopic beat morphology type. That is, as an example, three different ectopic beat morphologies can be detected that exhibit three different QRS characteristics.

**[0056]** The method can further include generating ectopic beat-compensated electrical heterogeneity information 446. The monitored electrical activity can be used to generate electrical heterogeneity information. The metrics of electrical heterogeneity can include a metric of standard deviation of activation times (SDAT) of electrodes on a left side of a torso of the patient. The metrics of electrical heterogeneity can include a metric of mean left ventricular activation time (LVAT) of electrodes on the left side of the torso of the patient. The metrics of electrical heterogeneity can include a metric of LVAT determined from electrodes on both the anterior and posterior surfaces. The metrics of electrical heterogeneity information can include a metric of mean right ventricular activation time (RVAT) of electrodes on the right side of the torso of the patient. The metrics of electrical heterogeneity can include a metric of RVAT determined from electrodes on both the anterior and posterior surfaces.

**[0057]** The generated electrical heterogeneity information (EHI) can be used with the detected ectopic beat information to generate ectopic beat-compensated electrical heterogeneity information (EBC EHI). The ectopic beat-compensated electrical heterogeneity information can factor in the impact of the ectopic beats during a selected time period (e.g., ectopic burden) in comparison to the impact of the pacing therapy (e.g., pacing burden). These burdens can be determined by any cardiac monitor that has monitored cardiac beats for any selected period of time. The period of time can be during a shorter period of time done while a patient is in clinic or the period of time can be throughout an entire day and collected passively by the cardiac monitor during a normal routine day for the patient and later collected from the data of the cardiac monitor.

**[0058]** As an example of determining the EBC EHI, the ectopic beat-compensated electrical heterogeneity can be equal to:

$$=(\text{Pacing burden} \times \text{SDAT}_{\text{pacing}}) + (\text{Ectopic burden} \times \text{SDAT}_{\text{ectopic}})$$

That is, the EHI (e.g.,  $\text{SDAT}_{\text{pacing}}$ ) during pacing can be multiplied by the burden of the pacing. The burden can refer to a percentage, a ratio, and/or a weighted quantity (e.g., number of beats, portion of a total number of beats, etc.) of beats out of a total number of beats. As an example, an ectopic burden can refer to a percentage, ratio, or weighted quantity, of ectopic beats in relation to a total number of beats. The result of that multiplication (e.g.,  $\text{Pacing burden} \times \text{SDAT}_{\text{pacing}}$ ) can be added to the EHI (e.g.,  $\text{SDAT}_{\text{ectopic}}$ ) during ectopic events multiplied by the ectopic burden. The addition of the burden-compensated EHI during pacing and the burden-compensated EHI during ectopic events can indicate the ectopic beat-compensated electrical heterogeneity information (EBC EHI). This EBC EHI can indicate

cardiac dyssynchrony either in the absence of pacing or, as in this example above, in the presence of pacing for those with ventricular ectopy in order to determine an effective electrical heterogeneity (e.g., effective SDAT) of the pacing therapy. The effective electrical heterogeneity can also be determined by modifying pacing modes (e.g., left-ventricular (LV) only vs. bi-ventricular (BV) pacing) and for different pacing times (e.g., like V-V delays for BV pacing).

**[0059]** The determination of the effective electrical heterogeneity may be performed by a device that may be programmed to parameters and/or settings that maximize the reduction between the corresponding effective electrical heterogeneity (e.g., effective SDAT) during therapy and during native (e.g., non-therapy) beats). Further, if for selected settings the effective electrical heterogeneity (e.g., SDAT) during therapy exceeds the electrical heterogeneity during non-pacing (e.g., native or intrinsic beats), a patient may be considered for greater risk of heart failure and/or additional clinical procedures (e.g., ablation) to minimize the PVC (or ectopic) burden. The ectopic beat-compensated EHI can be displayed on a display that includes a graphical user interface in order to assist a user in evaluating patient cardiac health.

**[0060]** FIG. 5 is a detailed block diagram of generating ectopic beat-compensated electrical heterogeneity information 446. The method 446 can be described as one exemplary embodiment of method step 446 in method 440 described in association with FIG. 4. That is, generating ectopic beat-compensated electrical heterogeneity information 446 of method 440 can include the steps of method 446 in FIG. 5. The method 446 can include generating electrical heterogeneity information (EHI) based on electrical activity of at least one ectopic beat 447. The at least one ectopic beat can include at least one ectopic beat monitored in the absence of pacing therapy and/or at least one ectopic beat monitored while delivering pacing therapy. The ectopic beat electrical heterogeneity information can include a metric of ectopic electrical heterogeneity (e.g., ectopic SDAT).

**[0061]** The method 446 can include generating electrical heterogeneity information (EHI) based on electrical activity of at least one non-ectopic beat 448. The at least one non-ectopic beat can include at least one of a beat monitored while delivering cardiac pacing therapy and an intrinsic (non-paced) beat monitored in the absence of delivering cardiac pacing therapy. The non-ectopic beat electrical heterogeneity information can include a metric of non-ectopic electrical heterogeneity (e.g., non-ectopic SDAT).

**[0062]** The method 446 can further include determining a burden of ectopic beats 450. That is, a burden of ectopic beats can refer to a percentage of ectopic beats. As an example, the percentage of ectopic beats can indicate a percentage of a total number of beats that are ectopic beats. The total number of beats can be beats monitored while delivering pacing therapy and/or in the absence of delivering pacing therapy. As an example, a total number of paced beats can include a subset of a total number of beats that were ectopic and the percentage of ectopic beats can indicate what portion of the total were ectopic.

**[0063]** The method 446 can further include adjusting non-ectopic beat electrical heterogeneity information (EHI) based on the percentage of the ectopic beats 452. The adjusting can include adjusting the determined non-ectopic

EHI based on a burden of the non-ectopic beats. The non-ectopic beats can include beats monitored during delivery of pacing therapy.

[0064] The method 446 can further include adjusting ectopic beat EHI based on the percentage of ectopic beats 454. The adjusting can include determining EHI for ectopic beats and adjusting the determined ectopic EHI based on a burden of the ectopic beats.

[0065] The method 446 can further include generating the EBCH EHI based on the adjusted non-ectopic beat EHI and the adjusted ectopic beat EHI 456. Cardiac therapy can be delivered by a cardiac therapy apparatus based on the generated ectopic beat-compensated electrical heterogeneity information. As an example, the delivered cardiac therapy can be modified in response to the generated ectopic beat-compensated electrical heterogeneity information. The modification of the delivered cardiac therapy can include modifying the delivered cardiac therapy based on a pre-determined set of settings. Then, a determination can be made as to which setting of the pre-determined set of settings results in minimal ectopic-beat compensated EHI. The modification of the delivered cardiac therapy can be repeated, using varying types of cardiac therapy, until the generated ectopic beat-compensated electrical heterogeneity information is less than or greater than a threshold.

[0066] The exemplary systems, methods, and graphical user interfaces described herein may be used with respect to the implantation and configuration of an implantable medical device (IMD) and/or one or more leads configured to be located proximate one or more portions of a patient's heart. For example, the exemplary systems, methods, and interfaces may be used in conjunction with an exemplary therapy system 10 described herein with reference to FIGS. 6-10.

[0067] FIG. 6 is a conceptual diagram illustrating an exemplary therapy system 10 that may be used to deliver pacing therapy to a patient 14. Patient 14 may, but not necessarily, be a human. The therapy system 10 may include an implantable medical device 16 (IMD), which may be coupled to leads 18, 20, 22. The IMD 16 may be, e.g., an implantable pacemaker, cardioverter, and/or defibrillator, that delivers, or provides, electrical signals (e.g., paces, etc.) to and/or senses electrical signals from the heart 12 of the patient 14 via electrodes coupled to one or more of the leads 18, 20, 22.

[0068] The leads 18, 20, 22 extend into the heart 12 of the patient 14 to sense electrical activity of the heart 12 and/or to deliver electrical stimulation to the heart 12. In the example shown in FIG. 6, the right ventricular (RV) lead 18 extends through one or more veins (not shown), the superior vena cava (not shown), and the right atrium 26, and into the right ventricle 28. The left ventricular (LV) coronary sinus lead 20 extends through one or more veins, the vena cava, the right atrium 26, and into the coronary sinus 30 to a region adjacent to the free wall of the left ventricle 32 of the heart 12. The right atrial (RA) lead 22 extends through one or more veins and the vena cava, and into the right atrium 26 of the heart 12.

[0069] The IMD 16 may sense, among other things, electrical signals attendant to the depolarization and repolarization of the heart 12 via electrodes coupled to at least one of the leads 18, 20, 22. In some examples, the IMD 16 provides pacing therapy (e.g., pacing pulses) to the heart 12 based on the electrical signals sensed within the heart 12. The IMD 16 may be operable to adjust one or more parameters associated

with the pacing therapy such as, e.g., AV delay and other various timings, pulse wide, amplitude, voltage, burst length, etc. Further, the IMD 16 may be operable to use various electrode configurations to deliver pacing therapy, which may be unipolar, bipolar, quadripolar, or further multipolar. For example, a multipolar lead may include several electrodes that can be used for delivering pacing therapy. Hence, a multipolar lead system may provide, or offer, multiple electrical vectors to pace from. A pacing vector may include at least one cathode, which may be at least one electrode located on at least one lead, and at least one anode, which may be at least one electrode located on at least one lead (e.g., the same lead, or a different lead) and/or on the casing, or can, of the IMD. While improvement in cardiac function as a result of the pacing therapy may primarily depend on the cathode, the electrical parameters like impedance, pacing threshold voltage, current drain, longevity, etc. may be more dependent on the pacing vector, which includes both the cathode and the anode. The IMD 16 may also provide defibrillation therapy and/or cardioversion therapy via electrodes located on at least one of the leads 18, 20, 22. Further, the IMD 16 may detect arrhythmia of the heart 12, such as fibrillation of the ventricles 28, 32, and deliver defibrillation therapy to the heart 12 in the form of electrical pulses. In some examples, IMD 16 may be programmed to deliver a progression of therapies, e.g., pulses with increasing energy levels, until a fibrillation of heart 12 is stopped.

[0070] FIGS. 7-8 are conceptual diagrams illustrating the IMD 16 and the leads 18, 20, 22 of therapy system 10 of FIG. 6 in more detail. The leads 18, 20, 22 may be electrically coupled to a therapy delivery module (e.g., for delivery of pacing therapy), a sensing module (e.g., for sensing one or more signals from one or more electrodes), and/or any other modules of the IMD 16 via a connector block 34. In some examples, the proximal ends of the leads 18, 20, 22 may include electrical contacts that electrically couple to respective electrical contacts within the connector block 34 of the IMD 16. In addition, in some examples, the leads 18, 20, 22 may be mechanically coupled to the connector block 34 with the aid of set screws, connection pins, or another suitable mechanical coupling mechanism.

[0071] Each of the leads 18, 20, 22 includes an elongated insulative lead body, which may carry a number of conductors (e.g., concentric coiled conductors, straight conductors, etc.) separated from one another by insulation (e.g., tubular insulative sheaths). In the illustrated example, bipolar electrodes 40, 42 are located proximate to a distal end of the lead 18. In addition, bipolar electrodes 44, 45, 46, 47 are located proximate to a distal end of the lead 20 and bipolar electrodes 48, 50 are located proximate to a distal end of the lead 22.

[0072] The electrodes 40, 44, 45, 46, 47, 48 may take the form of ring electrodes, and the electrodes 42, 50 may take the form of extendable helix tip electrodes mounted retractably within the insulative electrode heads 52, 54, 56, respectively. Each of the electrodes 40, 42, 44, 45, 46, 47, 48, 50 may be electrically coupled to a respective one of the conductors (e.g., coiled and/or straight) within the lead body of its associated lead 18, 20, 22, and thereby coupled to a respective one of the electrical contacts on the proximal end of the leads 18, 20, 22.

[0073] Additionally, electrodes 44, 45, 46 and 47 may have an electrode surface area of about 5.3 mm<sup>2</sup> to about 5.8

mm<sup>2</sup>. Electrodes **44**, **45**, **46**, and **47** may also be referred to as LV1, LV2, LV3, and LV4, respectively. The LV electrodes (i.e., left ventricle electrode 1 (LV1) **44**, left ventricle electrode 2 (LV2) **45**, left ventricle electrode 3 (LV3) **46**, and left ventricle 4 (LV4) **47** etc.) on the lead **20** can be spaced apart at variable distances. For example, electrode **44** may be a distance of, e.g., about 21 millimeters (mm), away from electrode **45**, electrodes **45** and **46** may be spaced a distance of, e.g. about 1.3 mm to about 1.5 mm, away from each other, and electrodes **46** and **47** may be spaced a distance of, e.g. 20 mm to about 21 mm, away from each other.

[0074] The electrodes **40**, **42**, **44**, **45**, **46**, **47**, **48**, **50** may further be used to sense electrical signals (e.g., morphological waveforms within electrograms (EGM)) attendant to the depolarization and repolarization of the heart **12**. The electrical signals are conducted to the IMD **16** via the respective leads **18**, **20**, **22**. In some examples, the IMD **16** may also deliver pacing pulses via the electrodes **40**, **42**, **44**, **45**, **46**, **47**, **48**, **50** to cause depolarization of cardiac tissue of the patient's heart **12**. In some examples, as illustrated in FIG. 7, the IMD **16** includes one or more housing electrodes, such as housing electrode **58**, which may be formed integrally with an outer surface of a housing **60** (e.g., hermetically-sealed housing) of the IMD **16** or otherwise coupled to the housing **60**. Any of the electrodes **40**, **42**, **44**, **45**, **46**, **47**, **48**, **50** may be used for unipolar sensing or pacing in combination with the housing electrode **58**. It is generally understood by those skilled in the art that other electrodes can also be selected to define, or be used for, pacing and sensing vectors. Further, any of electrodes **40**, **42**, **44**, **45**, **46**, **47**, **48**, **50**, **58**, when not being used to deliver pacing therapy, may be used to sense electrical activity during pacing therapy.

[0075] As described in further detail with reference to FIG. 7, the housing **60** may enclose a therapy delivery module that may include a stimulation generator for generating cardiac pacing pulses and defibrillation or cardioversion shocks, as well as a sensing module for monitoring the electrical signals of the patient's heart (e.g., the patient's heart rhythm). The leads **18**, **20**, **22** may also include elongated electrodes **62**, **64**, **66**, respectively, which may take the form of a coil. The IMD **16** may deliver defibrillation shocks to the heart **12** via any combination of the elongated electrodes **62**, **64**, **66** and the housing electrode **58**. The electrodes **58**, **62**, **64**, **66** may also be used to deliver cardioversion pulses to the heart **12**. Further, the electrodes **62**, **64**, **66** may be fabricated from any suitable electrically conductive material, such as, but not limited to, platinum, platinum alloy, and/or other materials known to be usable in implantable defibrillation electrodes. Since electrodes **62**, **64**, **66** are not generally configured to deliver pacing therapy, any of electrodes **62**, **64**, **66** may be used to sense electrical activity and may be used in combination with any of electrodes **40**, **42**, **44**, **45**, **46**, **47**, **48**, **50**, **58**. In at least one embodiment, the RV elongated electrode **62** may be used to sense electrical activity of a patient's heart during the delivery of pacing therapy (e.g., in combination with the housing electrode **58**, or defibrillation electrode-to-housing electrode vector).

[0076] The configuration of the exemplary therapy system **10** illustrated in FIGS. 7-11 is merely one example. In other examples, the therapy system may include epicardial leads and/or patch electrodes instead of or in addition to the transvenous leads **18**, **20**, **22** illustrated in FIG. 6. Additionally, in other examples, the therapy system **10** may be

implanted in/around the cardiac space without transvenous leads (e.g., leadless/wireless pacing systems) or with leads implanted (e.g., implanted transvenously or using approaches) into the left chambers of the heart (in addition to or replacing the transvenous leads placed into the right chambers of the heart as illustrated in FIG. 6). Further, in one or more embodiments, the IMD **16** need not be implanted within the patient **14**. For example, the IMD **16** may deliver various cardiac therapies to the heart **12** via percutaneous leads that extend through the skin of the patient **14** to a variety of positions within or outside of the heart **12**. In one or more embodiments, the system **10** may utilize wireless pacing (e.g., using energy transmission to the intracardiac pacing component(s) via ultrasound, inductive coupling, RF, etc.) and sensing cardiac activation using electrodes on the can/housing and/or on subcutaneous leads.

[0077] In other examples of therapy systems that provide electrical stimulation therapy to the heart **12**, such therapy systems may include any suitable number of leads coupled to the IMD **16**, and each of the leads may extend to any location within or proximate to the heart **12**. For example, other examples of therapy systems may include three transvenous leads located as illustrated in FIGS. 9-11. Still further, other therapy systems may include a single lead that extends from the IMD **16** into the right atrium **26** or the right ventricle **28**, or two leads that extend into a respective one of the right atrium **26** and the right ventricle **28**.

[0078] FIG. 9 is a functional block diagram of one exemplary configuration of the IMD **16**. As shown, the IMD **16** may include a control module **81**, a therapy delivery module **84** (e.g., which may include a stimulation generator), a sensing module **86**, and a power source **90**.

[0079] The control module **81** may include a processor **80**, memory **82**, and a telemetry module **88**. The memory **82** may include computer-readable instructions that, when executed, e.g., by the processor **80**, cause the IMD **16** and/or the control module **81** to perform various functions attributed to the IMD **16** and/or the control module **81** described herein. Further, the memory **82** may include any volatile, non-volatile, magnetic, optical, and/or electrical media, such as a random-access memory (RAM), read-only memory (ROM), non-volatile RAM (NVRAM), electrically-erasable programmable ROM (EEPROM), flash memory, and/or any other digital media. An exemplary capture management module may be the left ventricular capture management (LVCM) module described in U.S. Pat. No. 7,684,863 entitled "LV THRESHOLD MEASUREMENT AND CAPTURE MANAGEMENT" and issued Mar. 23, 2010, which is incorporated herein by reference in its entirety.

[0080] The processor **80** of the control module **81** may include any one or more of a microprocessor, a controller, a digital signal processor (DSP), an application specific integrated circuit (ASIC), a field-programmable gate array (FPGA), and/or equivalent discrete or integrated logic circuitry. In some examples, the processor **80** may include multiple components, such as any combination of one or more microprocessors, one or more controllers, one or more DSPs, one or more ASICs, and/or one or more FPGAs, as well as other discrete or integrated logic circuitry. The functions attributed to the processor **80** herein may be embodied as software, firmware, hardware, or any combination thereof.

[0081] The control module **81** may control the therapy delivery module **84** to deliver therapy (e.g., electrical stimu-

lation therapy such as pacing) to the heart **12** according to a selected one or more therapy programs, which may be stored in the memory **82**. More, specifically, the control module **81** (e.g., the processor **80**) may control various parameters of the electrical stimulus delivered by the therapy delivery module **84** such as, e.g., AV delays, VV delays, pacing pulses with the amplitudes, pulse widths, frequency, or electrode polarities, etc., which may be specified by one or more selected therapy programs (e.g., AV and/or VV delay adjustment programs, pacing therapy programs, pacing recovery programs, capture management programs, etc.). As shown, the therapy delivery module **84** is electrically coupled to electrodes **40, 42, 44, 45, 46, 47, 48, 50, 58, 62, 64, 66**, e.g., via conductors of the respective lead **18, 20, 22**, or, in the case of housing electrode **58**, via an electrical conductor disposed within housing **60** of IMD **16**. Therapy delivery module **84** may be configured to generate and deliver electrical stimulation therapy such as pacing therapy to the heart **12** using one or more of the electrodes **40, 42, 44, 45, 46, 47, 48, 50, 58, 62, 64, 66**.

[0082] For example, therapy delivery module **84** may deliver pacing stimulus (e.g., pacing pulses) via ring electrodes **40, 44, 45, 46, 47, 48** coupled to leads **18, 20, 22** and/or helical tip electrodes **42, 50** of leads **18, 22**. Further, for example, therapy delivery module **84** may deliver defibrillation shocks to heart **12** via at least two of electrodes **58, 62, 64, 66**. In some examples, therapy delivery module **84** may be configured to deliver pacing, cardioversion, or defibrillation stimulation in the form of electrical pulses. In other examples, therapy delivery module **84** may be configured deliver one or more of these types of stimulation in the form of other signals, such as sine waves, square waves, and/or other substantially continuous time signals.

[0083] The IMD **16** may further include a switch module **85** and the control module **81** (e.g., the processor **80**) may use the switch module **85** to select, e.g., via a data/address bus, which of the available electrodes are used to deliver therapy such as pacing pulses for pacing therapy, or which of the available electrodes are used for sensing. The switch module **85** may include a switch array, switch matrix, multiplexer, or any other type of switching device suitable to selectively couple the sensing module **86** and/or the therapy delivery module **84** to one or more selected electrodes. More specifically, the therapy delivery module **84** may include a plurality of pacing output circuits. Each pacing output circuit of the plurality of pacing output circuits may be selectively coupled, e.g., using the switch module **85**, to one or more of the electrodes **40, 42, 44, 45, 46, 47, 48, 50, 58, 62, 64, 66** (e.g., a pair of electrodes for delivery of therapy to a bipolar or multipolar pacing vector). In other words, each electrode can be selectively coupled to one of the pacing output circuits of the therapy delivery module using the switching module **85**.

[0084] The sensing module **86** is coupled (e.g., electrically coupled) to sensing apparatus, which may include, among additional sensing apparatus, the electrodes **40, 42, 44, 45, 46, 47, 48, 50, 58, 62, 64, 66** to monitor electrical activity of the heart **12**, e.g., electrocardiogram (ECG)/electrogram (EGM) signals, etc. The ECG/EGM signals may be used to measure or monitor activation times (e.g., ventricular activations times, etc.), heart rate (HR), heart rate variability (HRV), heart rate turbulence (HRT), deceleration/acceleration capacity, deceleration sequence incidence, T-wave alternans (TWA), P-wave to P-wave intervals (also referred to as

the P-P intervals or A-A intervals), R-wave to R-wave intervals (also referred to as the R-R intervals or V-V intervals), P-wave to QRS complex intervals (also referred to as the P-R intervals, A-V intervals, or P-Q intervals), QRS-complex morphology, ST segment (i.e., the segment that connects the QRS complex and the T-wave), T-wave changes, QT intervals, electrical vectors, etc.

[0085] The switch module **85** may also be used with the sensing module **86** to select which of the available electrodes are used, or enabled, to, e.g., sense electrical activity of the patient's heart (e.g., one or more electrical vectors of the patient's heart using any combination of the electrodes **40, 42, 44, 45, 46, 47, 48, 50, 58, 62, 64, 66**). Likewise, the switch module **85** may also be used with the sensing module **86** to select which of the available electrodes are not to be used (e.g., disabled) to, e.g., sense electrical activity of the patient's heart (e.g., one or more electrical vectors of the patient's heart using any combination of the electrodes **40, 42, 44, 45, 46, 47, 48, 50, 58, 62, 64, 66**), etc. In some examples, the control module **81** may select the electrodes that function as sensing electrodes via the switch module within the sensing module **86**, e.g., by providing signals via a data/address bus.

[0086] In some examples, sensing module **86** includes a channel that includes an amplifier with a relatively wider pass band than the R-wave or P-wave amplifiers. Signals from the selected sensing electrodes may be provided to a multiplexer, and thereafter converted to multi-bit digital signals by an analog-to-digital converter for storage in memory **82**, e.g., as an electrogram (EGM). In some examples, the storage of such EGMs in memory **82** may be under the control of a direct memory access circuit.

[0087] In some examples, the control module **81** may operate as an interrupt driven device, and may be responsive to interrupts from pacer timing and control module, where the interrupts may correspond to the occurrences of sensed P-waves and R-waves and the generation of cardiac pacing pulses. Any necessary mathematical calculations may be performed by the processor **80** and any updating of the values or intervals controlled by the pacer timing and control module may take place following such interrupts. A portion of memory **82** may be configured as a plurality of recirculating buffers, capable of holding one or more series of measured intervals, which may be analyzed by, e.g., the processor **80** in response to the occurrence of a pace or sense interrupt to determine whether the patient's heart **12** is presently exhibiting atrial or ventricular tachyarrhythmia.

[0088] The telemetry module **88** of the control module **81** may include any suitable hardware, firmware, software, or any combination thereof for communicating with another device, such as a programmer. For example, under the control of the processor **80**, the telemetry module **88** may receive downlink telemetry from and send uplink telemetry to a programmer with the aid of an antenna, which may be internal and/or external. The processor **80** may provide the data to be uplinked to a programmer and the control signals for the telemetry circuit within the telemetry module **88**, e.g., via an address/data bus. In some examples, the telemetry module **88** may provide received data to the processor **80** via a multiplexer.

[0089] The various components of the IMD **16** are further coupled to a power source **90**, which may include a rechargeable or non-rechargeable battery. A non-rechargeable battery may be selected to last for several years, while

a rechargeable battery may be inductively charged from an external device, e.g., on a daily or weekly basis.

[0090] FIG. 10 is another embodiment of a functional block diagram for IMD 16. FIG. 10 depicts bipolar RA lead 22, bipolar RV lead 18, and bipolar LV CS lead 20 without the LA CS pace/sense electrodes and coupled with an implantable pulse generator (IPG) circuit 31 having programmable modes and parameters of a bi-ventricular DDD/R type known in the pacing art. In turn, the sensor signal processing circuit 91 indirectly couples to the timing circuit 43 and via data and control bus to microcomputer circuitry 33. The IPG circuit 31 is illustrated in a functional block diagram divided generally into a microcomputer circuit 33 and a pacing circuit 21. The pacing circuit 21 includes the digital controller/timer circuit 43, the output amplifiers circuit 51, the sense amplifiers circuit 55, the RF telemetry transceiver 41, the activity sensor circuit 35 as well as a number of other circuits and components described below.

[0091] Crystal oscillator circuit 89 provides the basic timing clock for the pacing circuit 21 while battery 29 provides power. Power-on-reset circuit 87 responds to initial connection of the circuit to the battery for defining an initial operating condition and similarly, resets the operative state of the device in response to detection of a low battery condition. Reference mode circuit 37 generates stable voltage reference and currents for the analog circuits within the pacing circuit 21. Analog-to-digital converter (ADC) and multiplexer circuit 39 digitize analog signals and voltage to provide, e.g., real time telemetry of cardiac signals from sense amplifiers 55 for uplink transmission via RF transmitter and receiver circuit 41. Voltage reference and bias circuit 37, ADC and multiplexer 39, power-on-reset circuit 87, and crystal oscillator circuit 89 may correspond to any of those used in exemplary implantable cardiac pacemakers.

[0092] If the IPG is programmed to a rate responsive mode, the signals output by one or more physiologic sensors are employed as a rate control parameter (RCP) to derive a physiologic escape interval. For example, the escape interval is adjusted proportionally to the patient's activity level developed in the patient activity sensor (PAS) circuit 35 in the depicted, exemplary IPG circuit 31. The patient activity sensor 27 is coupled to the IPG housing and may take the form of a piezoelectric crystal transducer. The output signal of the patient activity sensor 27 may be processed and used as a RCP. Sensor 27 generates electrical signals in response to sensed physical activity that are processed by activity circuit 35 and provided to digital controller/timer circuit 43. Activity circuit 35 and associated sensor 27 may correspond to the circuitry disclosed in U.S. Pat. No. 5,052,388 entitled "METHOD AND APPARATUS FOR IMPLEMENTING ACTIVITY SENSING IN A PULSE GENERATOR" and issued on Oct. 1, 1991 and U.S. Pat. No. 4,428,378 entitled "RATE ADAPTIVE PACER" and issued on Jan. 31, 1984, each of which is incorporated herein by reference in its entirety. Similarly, the exemplary systems, apparatus, and methods described herein may be practiced in conjunction with alternate types of sensors such as oxygenation sensors, pressure sensors, pH sensors, and respiration sensors, for use in providing rate responsive pacing capabilities. Alternately, QT time may be used as a rate indicating parameter, in which case no extra sensor is required. Similarly, the exemplary embodiments described herein may also be practiced in non-rate responsive pacemakers.

[0093] Data transmission to and from the external programmer is accomplished by way of the telemetry antenna 57 and an associated RF transceiver 41, which serves both to demodulate received downlink telemetry and to transmit uplink telemetry. Uplink telemetry capabilities may include the ability to transmit stored digital information, e.g., operating modes and parameters, EGM histograms, and other events, as well as real time EGMs of atrial and/or ventricular electrical activity and marker channel pulses indicating the occurrence of sensed and paced depolarizations in the atrium and ventricle.

[0094] Microcomputer 33 contains a microprocessor 80 and associated system clock and on-processor RAM and ROM chips 82A and 82B, respectively. In addition, microcomputer circuit 33 includes a separate RAM/ROM chip 82C to provide additional memory capacity. Microprocessor 80 normally operates in a reduced power consumption mode and is interrupt driven. Microprocessor 80 is awakened in response to defined interrupt events, which may include A-TRIG, RV-TRIG, LV-TRIG signals generated by timers in digital timer/controller circuit 43 and A-EVENT, RV-EVENT, and LV-EVENT signals generated by sense amplifiers circuit 55, among others. The specific values of the intervals and delays timed out by digital controller/timer circuit 43 are controlled by the microcomputer circuit 33 by way of data and control bus from programmed-in parameter values and operating modes. In addition, if programmed to operate as a rate responsive pacemaker, a timed interrupt, e.g., every cycle or every two seconds, may be provided in order to allow the microprocessor to analyze the activity sensor data and update the basic A-A, V-A, or V-V escape interval, as applicable. In addition, the microprocessor 80 may also serve to define variable, operative AV delay intervals, V-V delay intervals, and the energy delivered to each ventricle and/or atrium.

[0095] In one embodiment, microprocessor 80 is a custom microprocessor adapted to fetch and execute instructions stored in RAM/ROM unit 82 in a conventional manner. It is contemplated, however, that other implementations may be suitable to practice the present invention. For example, an off-the-shelf, commercially available microprocessor or microcontroller, or custom application-specific, hardwired logic, or state-machine type circuit may perform the functions of microprocessor 80.

[0096] Digital controller/timer circuit 43 operates under the general control of the microcomputer 33 to control timing and other functions within the pacing circuit 21 and includes a set of timing and associated logic circuits of which certain ones pertinent to the present invention are depicted. The depicted timing circuits include URI/LRI timers 83A, V-V delay timer 83B, intrinsic interval timers 83C for timing elapsed V-EVENT to V-EVENT intervals or V-EVENT to A-EVENT intervals or the V-V conduction interval, escape interval timers 83D for timing A-A, V-A, and/or V-V pacing escape intervals, an AV delay interval timer 83E for timing the A-LVp delay (or A-RVp delay) from a preceding A-EVENT or A-TRIG, a post-ventricular timer 83F for timing post-ventricular time periods, and a date/time clock 83G.

[0097] The AV delay interval timer 83E is loaded with an appropriate delay interval for one ventricular chamber (e.g., either an A-RVp delay or an A-LVp) to time-out starting from a preceding A-PACE or A-EVENT. The interval timer 83E triggers pacing stimulus delivery, and can be based on

one or more prior cardiac cycles (or from a data set empirically derived for a given patient).

**[0098]** The post-event timer **83F** times out the post-ventricular time period following an RV-EVENT or LV-EVENT or a RV-TRIG or LV-TRIG and post-atrial time periods following an A-EVENT or A-TRIG. The durations of the post-event time periods may also be selected as programmable parameters stored in the microcomputer **33**. The post-ventricular time periods include the PVARP, a post-atrial ventricular blanking period (PAVBP), a ventricular blanking period (VBP), a post-ventricular atrial blanking period (PVARP) and a ventricular refractory period (VRP) although other periods can be suitably defined depending, at least in part, on the operative circuitry employed in the pacing engine. The post-atrial time periods include an atrial refractory period (ARP) during which an A-EVENT is ignored for the purpose of resetting any AV delay, and an atrial blanking period (ABP) during which atrial sensing is disabled. It should be noted that the starting of the post-atrial time periods and the AV delays can be commenced substantially simultaneously with the start or end of each A-EVENT or A-TRIG or, in the latter case, upon the end of the A-PACE which may follow the A-TRIG. Similarly, the starting of the post-ventricular time periods and the V-A escape interval can be commenced substantially simultaneously with the start or end of the V-EVENT or V-TRIG or, in the latter case, upon the end of the V-PACE which may follow the V-TRIG. The microprocessor **80** also optionally calculates AV delays, VV delays, post-ventricular time periods, and post-atrial time periods that vary with the sensor based escape interval established in response to the RCP(s) and/or with the intrinsic atrial and/or ventricular rate.

**[0099]** The output amplifiers circuit **51** contains a RA pace pulse generator (and a LA pace pulse generator if LA pacing is provided), a RV pace pulse generator, a LV pace pulse generator, and/or any other pulse generator configured to provide atrial and ventricular pacing. In order to trigger generation of an RV-PACE or LV-PACE pulse, digital controller/timer circuit **43** generates the RV-TRIG signal at the time-out of the A-RVp delay (in the case of RV pre-excitation) or the LV-TRIG at the time-out of the A-LVp delay (in the case of LV pre-excitation) provided by AV delay interval timer **83E** (or the V-V delay timer **83B**). Similarly, digital controller/timer circuit **43** generates an RA-TRIG signal that triggers output of an RA-PACE pulse (or an LA-TRIG signal that triggers output of an LA-PACE pulse, if provided) at the end of the V-A escape interval timed by escape interval timers **83D**.

**[0100]** The output amplifiers circuit **51** includes switching circuits for coupling selected pace electrode pairs from among the lead conductors and the IND-CAN electrode **20** to the RA pace pulse generator (and LA pace pulse generator if provided), RV pace pulse generator and LV pace pulse generator. Pace/sense electrode pair selection and control circuit **53** selects lead conductors and associated pace electrode pairs to be coupled with the atrial and ventricular output amplifiers within output amplifiers circuit **51** for accomplishing RA, LA, RV and LV pacing.

**[0101]** The sense amplifiers circuit **55** contains sense amplifiers for atrial and ventricular pacing and sensing. High impedance P-wave and R-wave sense amplifiers may be used to amplify a voltage difference signal that is generated across the sense electrode pairs by the passage of cardiac depolarization wavefronts. The high impedance sense

amplifiers use high gain to amplify the low amplitude signals and rely on pass band filters, time domain filtering and amplitude threshold comparison to discriminate a P-wave or R-wave from background electrical noise. Digital controller/timer circuit **43** controls sensitivity settings of the atrial and ventricular sense amplifiers **55**.

**[0102]** The sense amplifiers may be uncoupled from the sense electrodes during the blanking periods before, during, and after delivery of a pace pulse to any of the pace electrodes of the pacing system to avoid saturation of the sense amplifiers. The sense amplifiers circuit **55** includes blanking circuits for uncoupling the selected pairs of the lead conductors and the IND-CAN electrode **20** from the inputs of the RA sense amplifier (and LA sense amplifier if provided), RV sense amplifier and LV sense amplifier during the ABP, PVABP and VBP. The sense amplifiers circuit **55** also includes switching circuits for coupling selected sense electrode lead conductors and the IND-CAN electrode **20** to the RA sense amplifier (and LA sense amplifier if provided), RV sense amplifier and LV sense amplifier. Again, sense electrode selection and control circuit **53** selects conductors and associated sense electrode pairs to be coupled with the atrial and ventricular sense amplifiers within the output amplifiers circuit **51** and sense amplifiers circuit **55** for accomplishing RA, LA, RV, and LV sensing along desired unipolar and bipolar sensing vectors.

**[0103]** Right atrial depolarizations or P-waves in the RA-SENSE signal that are sensed by the RA sense amplifier result in a RA-EVENT signal that is communicated to the digital controller/timer circuit **43**. Similarly, left atrial depolarizations or P-waves in the LA-SENSE signal that are sensed by the LA sense amplifier, if provided, result in a LA-EVENT signal that is communicated to the digital controller/timer circuit **43**. Ventricular depolarizations or R-waves in the RV-SENSE signal are sensed by a ventricular sense amplifier result in an RV-EVENT signal that is communicated to the digital controller/timer circuit **43**. Similarly, ventricular depolarizations or R-waves in the LV-SENSE signal are sensed by a ventricular sense amplifier result in an LV-EVENT signal that is communicated to the digital controller/timer circuit **43**. The RV-EVENT, LV-EVENT, and RA-EVENT, LA-SENSE signals may be refractory or non-refractory, and can inadvertently be triggered by electrical noise signals or aberrantly conducted depolarization waves rather than true R-waves or P-waves.

**[0104]** The techniques described in this disclosure, including those attributed to the IMD **16**, the computing apparatus **140**, and/or various constituent components, may be implemented, at least in part, in hardware, software, firmware, or any combination thereof. For example, various aspects of the techniques may be implemented within one or more processors, including one or more microprocessors, DSPs, ASICs, FPGAs, or any other equivalent integrated or discrete logic circuitry, as well as any combinations of such components, embodied in programmers, such as physician or patient programmers, stimulators, image processing devices, or other devices. The term "module," "processor," or "processing circuitry" may generally refer to any of the foregoing logic circuitry, alone or in combination with other logic circuitry, or any other equivalent circuitry.

**[0105]** Such hardware, software, and/or firmware may be implemented within the same device or within separate devices to support the various operations and functions described in this disclosure. In addition, any of the described

units, modules, or components may be implemented together or separately as discrete but interoperable logic devices. Depiction of different features as modules or units is intended to highlight different functional aspects and does not necessarily imply that such modules or units must be realized by separate hardware or software components. Rather, functionality associated with one or more modules or units may be performed by separate hardware or software components, or integrated within common or separate hardware or software components.

**[0106]** When implemented in software, the functionality ascribed to the systems, devices and techniques described in this disclosure may be embodied as instructions on a computer-readable medium such as RAM, ROM, NVRAM, EEPROM, FLASH memory, magnetic data storage media, optical data storage media, or the like. The instructions may be executed by one or more processors to support one or more aspects of the functionality described in this disclosure.

**[0107]** This disclosure has been provided with reference to illustrative embodiments and is not meant to be construed in a limiting sense. As described previously, one skilled in the art will recognize that other various illustrative applications may use the techniques as described herein to take advantage of the beneficial characteristics of the apparatus and methods described herein. Various modifications of the illustrative embodiments, as well as additional embodiments of the disclosure, will be apparent upon reference to this description.

## ILLUSTRATIVE EMBODIMENTS

### Embodiment 1

**[0108]** A system comprising:

**[0109]** electrode apparatus comprising a plurality of external electrodes to monitor electrical activity from tissue of a patient; and

**[0110]** computing apparatus comprising processing circuitry and coupled to the electrode apparatus and configured to:

**[0111]** monitor electrical activity using the plurality of external electrodes;

**[0112]** provide ectopic beat information; and

**[0113]** generate ectopic beat-compensated electrical heterogeneity information based on the monitored electrical activity and the ectopic beat information.

### Embodiment 2

**[0114]** The system of embodiment 1, wherein the plurality of external electrodes comprises surface electrodes positioned in an array configured to be located proximate skin of a torso of the patient.

### Embodiment 3

**[0115]** The system as set forth in any one of embodiments 1 to 2, wherein the system further comprises a display, wherein the display comprises a graphical user interface configured to assist a user in evaluating patient cardiac health, wherein the computing apparatus is further configured to display the ectopic beat-compensated electrical heterogeneity information on the graphical user interface.

### Embodiment 4

**[0116]** The system as set forth in any one of embodiments 1 to 3, wherein the generating the ectopic beat-compensated electrical heterogeneity information comprises generating the ectopic beat-compensated electrical heterogeneity information based on electrical activity monitored during at least one ectopic beat.

### Embodiment 5

**[0117]** The system as set forth in any one of embodiments 1 to 4, wherein the generating the ectopic beat-compensated electrical heterogeneity information comprises generating ectopic beat-compensated electrical heterogeneity information based on electrical activity monitored during at least one non-ectopic beat.

### Embodiment 6

**[0118]** The system of embodiment 5, wherein the at least one non-ectopic beat comprises one of a beat monitored while delivering cardiac pacing therapy and an intrinsic beat monitored in the absence of delivering cardiac pacing therapy.

### Embodiment 7

**[0119]** The system as set forth in any one of embodiments 1 to 6, wherein the ectopic beat information comprises a percentage of ectopic beats of a plurality of beats over a selected period of time.

### Embodiment 8

**[0120]** The system as set forth in any one of embodiments 1 to 7, wherein the ectopic beat information is provided using at least one of an implantable cardiac device, a subcutaneous cardiac monitor, an external cardiac monitor, and the plurality of external electrodes of the electrode apparatus.

### Embodiment 9

**[0121]** The system as set forth in any one of embodiments 1 to 8, comprising a cardiac therapy apparatus to deliver cardiac therapy based on the generated ectopic beat-compensated electrical heterogeneity information, wherein the computing apparatus is further configured to modify the cardiac therapy in response to the generated ectopic beat-compensated electrical heterogeneity information.

### Embodiment 10

**[0122]** The system of embodiment 9, wherein the modification of the delivered cardiac therapy is repeated until the generated ectopic beat-compensated electrical heterogeneity information is less than or greater than a threshold.

### Embodiment 11

**[0123]** The system as set forth in any one of embodiments 9, wherein:

**[0124]** the modification of the delivered cardiac therapy comprises modifying the delivered cardiac therapy based on a pre-determined set of settings, and

**[0125]** a determination is made as to which setting of the pre-determined set of settings results in minimal ectopic-beat compensated electrical heterogeneity information.

## Embodiment 12

[0126] A method comprising:  
 [0127] monitoring electrical activity from tissue of a patient using a plurality of external electrodes; and  
 [0128] generating ectopic beat-compensated electrical heterogeneity information based on the monitored electrical activity and ectopic beat information.

## Embodiment 13

[0129] The method of embodiment 12, wherein the plurality of external electrodes comprises surface electrodes positioned in an array configured to be located proximate skin of a torso of the patient.

## Embodiment 14

[0130] The method as set forth in any one of embodiments 12 to 13, further comprising displaying the ectopic beat-compensated electrical heterogeneity information on a graphical user interface to assist a user in evaluating patient cardiac health.

## Embodiment 15

[0131] The method as set forth in any one of embodiments 12 to 14, wherein the generating the ectopic beat-compensated electrical heterogeneity information comprises generating the ectopic beat-compensated electrical heterogeneity information based on electrical activity monitored during at least one ectopic beat.

## Embodiment 16

[0132] The method as set forth in any one of embodiments 12 to 15, wherein the generating the ectopic beat-compensated electrical heterogeneity information comprises generating ectopic beat-compensated electrical heterogeneity information based on electrical activity monitored during at least one non-ectopic beat.

## Embodiment 17

[0133] The method of embodiment 16, wherein the at least one non-ectopic beat comprises one of a beat monitored while delivering cardiac pacing therapy and an intrinsic beat monitored in the absence of delivering cardiac pacing therapy.

## Embodiment 18

[0134] The method as set forth in any one of embodiments 12 to 17, wherein the ectopic beat information comprises a ratio of ectopic beats of a plurality of beats over a selected period of time.

## Embodiment 19

[0135] The method as set forth in any one of embodiments 12 to 18, comprising:  
 [0136] delivering cardiac therapy based on the generated ectopic beat-compensated electrical heterogeneity information using a cardiac therapy apparatus; and  
 [0137] modifying the cardiac therapy in response to the generated ectopic beat-compensated electrical heterogeneity information.

## Embodiment 20

[0138] A system comprising:  
 [0139] electrode apparatus comprising a plurality of external electrodes to monitor electrical activity from tissue of a patient; and  
 [0140] computing apparatus comprising processing circuitry and coupled to the electrode apparatus and configured to:

- [0141] monitor electrical activity using the plurality of external electrodes;
- [0142] generate electrical heterogeneity information based on the monitored electrical activity; and
- [0143] adjust the electrical heterogeneity information to compensate for ectopic beats resulting in ectopic beat-compensated electrical heterogeneity information.

What is claimed:

1. A system comprising:  
 electrode apparatus comprising a plurality of external electrodes to monitor electrical activity from tissue of a patient; and  
 computing apparatus comprising processing circuitry and coupled to the electrode apparatus and configured to:  
 monitor electrical activity using the plurality of external electrodes;  
 provide ectopic beat information; and  
 generate ectopic beat-compensated electrical heterogeneity information based on the monitored electrical activity and the ectopic beat information.
2. The system of claim 1, wherein the plurality of external electrodes comprises surface electrodes positioned in an array configured to be located proximate skin of a torso of the patient.
3. The system of claim 1, wherein the system further comprises a display, wherein the display comprises a graphical user interface configured to assist a user in evaluating patient cardiac health, wherein the computing apparatus is further configured to display the ectopic beat-compensated electrical heterogeneity information on the graphical user interface.
4. The system of claim 1, wherein the generating the ectopic beat-compensated electrical heterogeneity information comprises generating the ectopic beat-compensated electrical heterogeneity information based on electrical activity monitored during at least one ectopic beat.
5. The system of claim 1, wherein the generating the ectopic beat-compensated electrical heterogeneity information comprises generating ectopic beat-compensated electrical heterogeneity information based on electrical activity monitored during at least one non-ectopic beat.
6. The system of claim 5, wherein the at least one non-ectopic beat comprises one of a beat monitored while delivering cardiac pacing therapy and an intrinsic beat monitored in the absence of delivering cardiac pacing therapy.
7. The system of claim 1, wherein the ectopic beat information comprises a percentage of ectopic beats of a plurality of beats over a selected period of time.
8. The system of claim 1, wherein the ectopic beat information is provided using at least one of an implantable cardiac device, a subcutaneous cardiac monitor, an external cardiac monitor, and the plurality of external electrodes of the electrode apparatus.
9. The system of claim 1, comprising a cardiac therapy apparatus to deliver cardiac therapy based on the generated

ectopic beat-compensated electrical heterogeneity information, wherein the computing apparatus is further configured to modify the cardiac therapy in response to the generated ectopic beat-compensated electrical heterogeneity information.

10. The system of claim 9, wherein the modification of the delivered cardiac therapy is repeated until the generated ectopic beat-compensated electrical heterogeneity information is less than or greater than a threshold.

11. The system of claim 9, wherein:

the modification of the delivered cardiac therapy comprises modifying the delivered cardiac therapy based on a pre-determined set of settings, and a determination is made as to which setting of the pre-determined set of settings results in minimal ectopic-beat compensated electrical heterogeneity information.

12. A method comprising:

monitoring electrical activity from tissue of a patient using a plurality of external electrodes; and generating ectopic beat-compensated electrical heterogeneity information based on the monitored electrical activity and ectopic beat information.

13. The method of claim 12, wherein the plurality of external electrodes comprises surface electrodes positioned in an array configured to be located proximate skin of a torso of the patient.

14. The method of claim 12, further comprising displaying the ectopic beat-compensated electrical heterogeneity information on a graphical user interface to assist a user in evaluating patient cardiac health.

15. The method of claim 12, wherein the generating the ectopic beat-compensated electrical heterogeneity information comprises generating the ectopic beat-compensated electrical heterogeneity information based on electrical activity monitored during at least one ectopic beat.

16. The method of claim 12, wherein the generating the ectopic beat-compensated electrical heterogeneity information comprises generating ectopic beat-compensated electrical heterogeneity information based on electrical activity monitored during at least one non-ectopic beat.

17. The method of claim 16, wherein the at least one non-ectopic beat comprises one of a beat monitored while delivering cardiac pacing therapy and an intrinsic beat monitored in the absence of delivering cardiac pacing therapy.

18. The method of claim 12, wherein the ectopic beat information comprises a ratio of ectopic beats of a plurality of beats over a selected period of time.

19. The method of claim 12, comprising:

delivering cardiac therapy based on the generated ectopic beat-compensated electrical heterogeneity information using a cardiac therapy apparatus; and

modifying the cardiac therapy in response to the generated ectopic beat-compensated electrical heterogeneity information.

20. A system comprising:

electrode apparatus comprising a plurality of external electrodes to monitor electrical activity from tissue of a patient; and

computing apparatus comprising processing circuitry and coupled to the electrode apparatus and configured to: monitor electrical activity using the plurality of external electrodes;

generate electrical heterogeneity information based on the monitored electrical activity; and

adjust the electrical heterogeneity information to compensate for ectopic beats resulting in ectopic beat-compensated electrical heterogeneity information.

\* \* \* \* \*

专利名称(译)	异位搏动补偿的电异质性信息		
公开(公告)号	<a href="#">US20190192023A1</a>	公开(公告)日	2019-06-27
申请号	US15/853160	申请日	2017-12-22
[标]申请(专利权)人(译)	美敦力公司		
申请(专利权)人(译)	美敦力公司, INC.		
当前申请(专利权)人(译)	美敦力公司, INC.		
[标]发明人	GHOSH SUBHAM		
发明人	GHOSH, SUBHAM		
IPC分类号	A61B5/04 A61B5/0408 A61B5/00 A61N1/365		
CPC分类号	A61B5/04012 A61B5/04085 A61B5/6823 A61B5/7435 A61B5/686 A61N1/36507 A61B5/0468 A61B5/6805 A61B5/6831 A61B2562/046 A61N1/3627 A61N1/37 A61N1/372		
外部链接	<a href="#">Espacenet</a> <a href="#">USPTO</a>		

摘要(译)

示例性系统和方法可以被配置用于确定异位搏动补偿的电异质性信息。可以通过多个外部电极监测电活动。可以检测到异位搏动信息。可以基于所监测的电活动和检测到的异位搏动信息来生成异位搏动补偿的电异质性信息。

