



(19) **United States**

(12) **Patent Application Publication**
Bolea et al.

(10) **Pub. No.: US 2019/0151656 A1**

(43) **Pub. Date: May 23, 2019**

(54) **OBSTRUCTIVE SLEEP APNEA TREATMENT DEVICES, SYSTEMS AND METHODS**

(22) Filed: **Oct. 18, 2018**

Related U.S. Application Data

(71) Applicant: **CYBERONICS, INC.**, Houston, TX (US)

(63) Continuation of application No. 12/980,840, filed on Dec. 29, 2010, now Pat. No. 10,105,538, which is a continuation of application No. 12/650,045, filed on Dec. 30, 2009, now Pat. No. 9,744,354.

(72) Inventors: **Stephen L. Bolea**, Watertown, MN (US); **Thomas B. Hoegh**, Edina, MN (US); **Brian D. Kuhnley**, Maple Grove, MN (US); **Dale G. Sulmann**, Elk River, MN (US); **Bruce J. Persson**, Dresser, WI (US); **John P. Beck**, Savage, MN (US); **Sidney F. Hauschild**, St. Paul, MN (US); **Paula M. Kaplan**, St. Paul, MN (US); **Adam K. Hoyhtya**, Shoreview, MN (US); **Wondimeneh Tesfayesus**, St. Paul, MN (US); **Robert E. Atkinson**, White Bear Lake, MN (US)

(60) Provisional application No. 61/204,008, filed on Dec. 31, 2008.

Publication Classification

(51) **Int. Cl.**
A61N 1/36 (2006.01)
A61B 5/053 (2006.01)
A61B 5/00 (2006.01)
A61N 1/05 (2006.01)

(52) **U.S. Cl.**
CPC *A61N 1/3601* (2013.01); *A61B 5/0538* (2013.01); *A61N 1/3611* (2013.01); *A61B 5/4818* (2013.01); *A61N 1/0556* (2013.01); *A61N 1/36139* (2013.01)

(73) Assignee: **CYBERONICS, INC.**, Houston, TX (US)

(57) **ABSTRACT**

(21) Appl. No.: **16/164,551**

Devices, systems and methods of neurostimulation for treating obstructive sleep apnea.

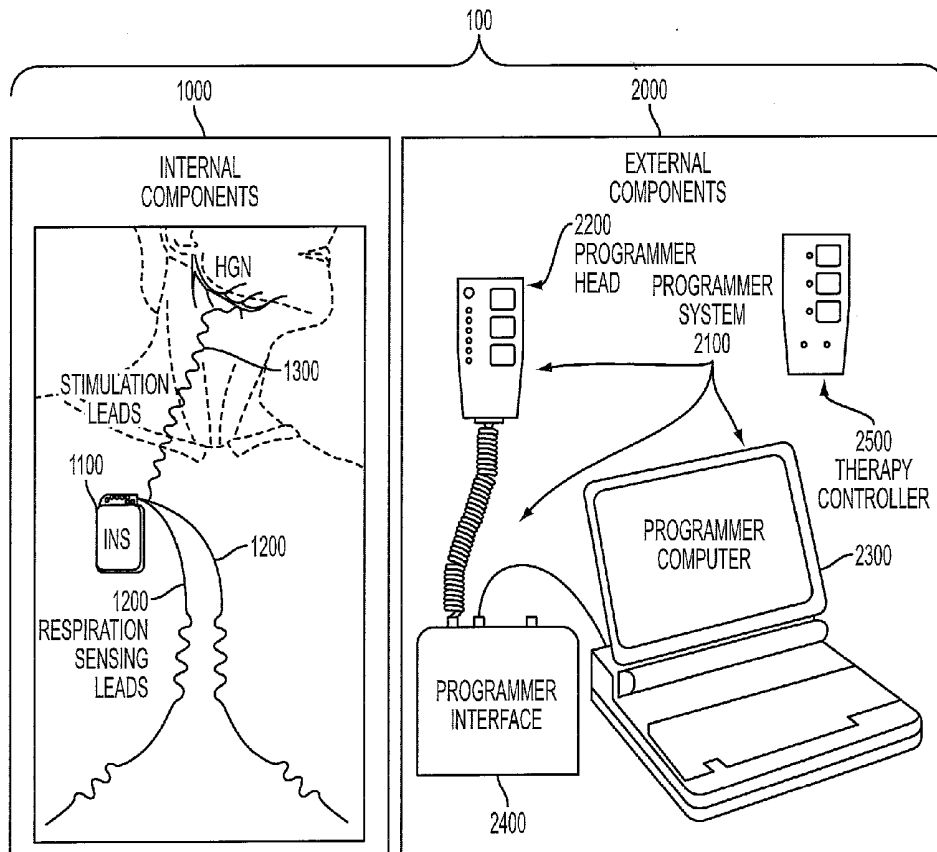

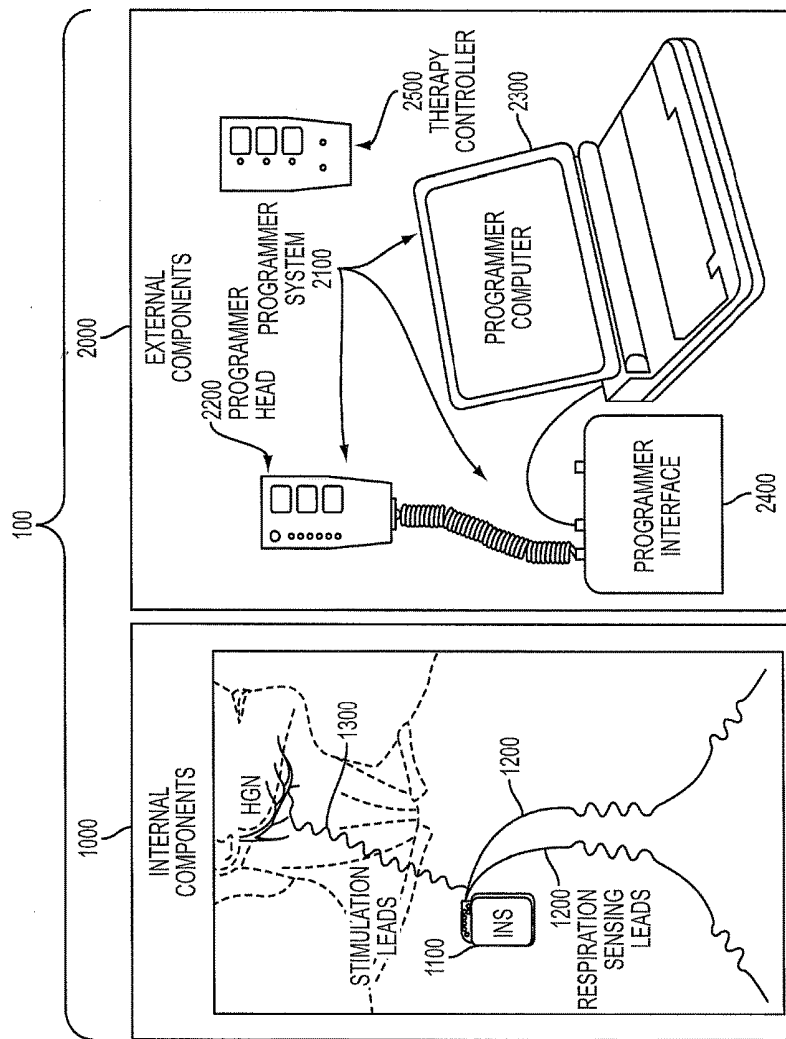
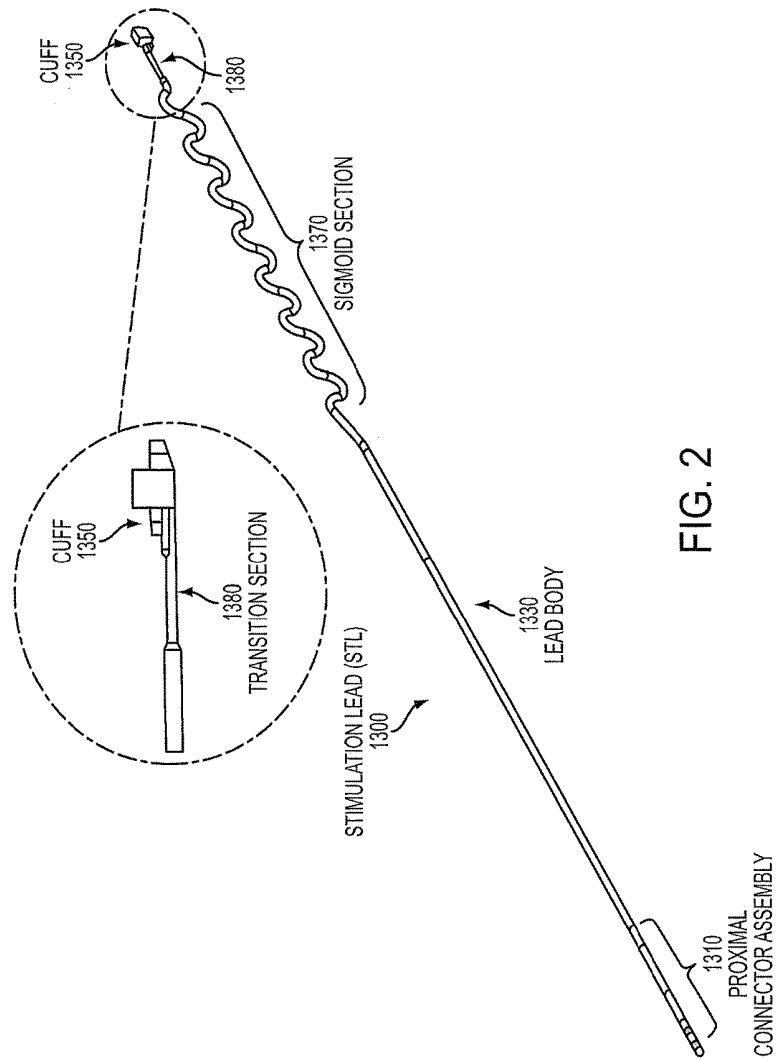

FIG. 1



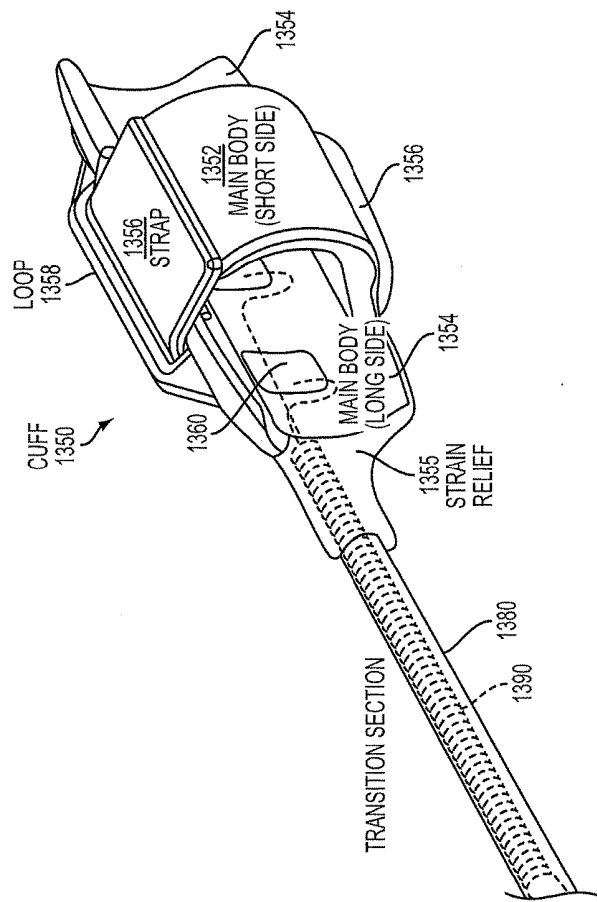

FIG. 3A

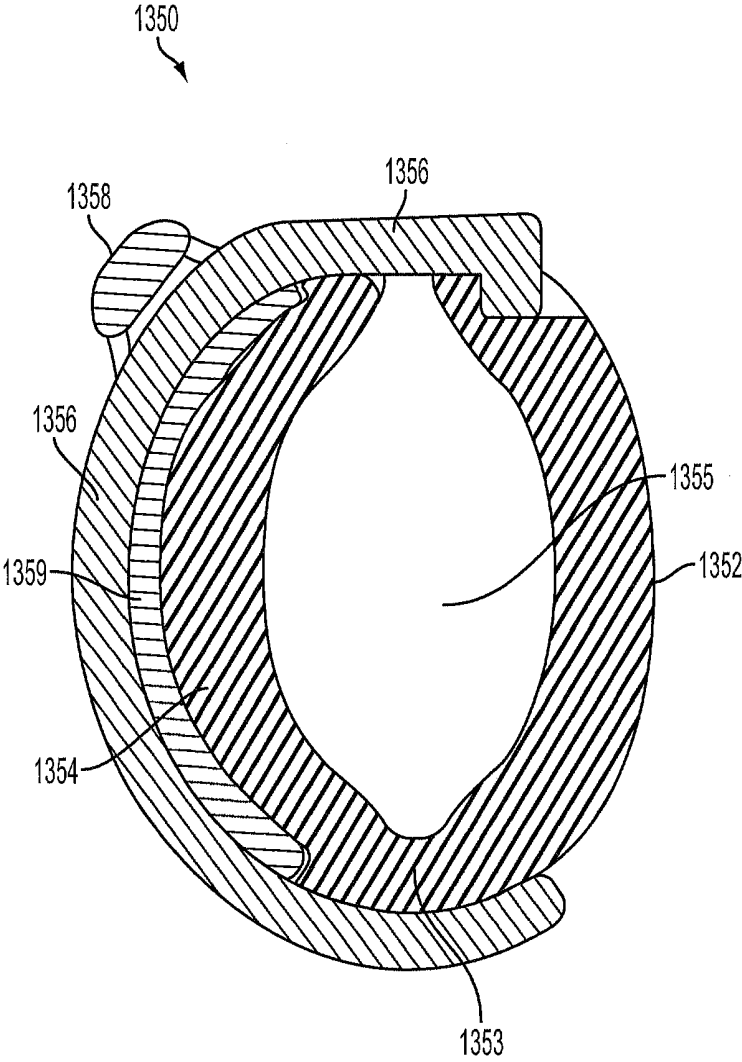

FIG. 3B

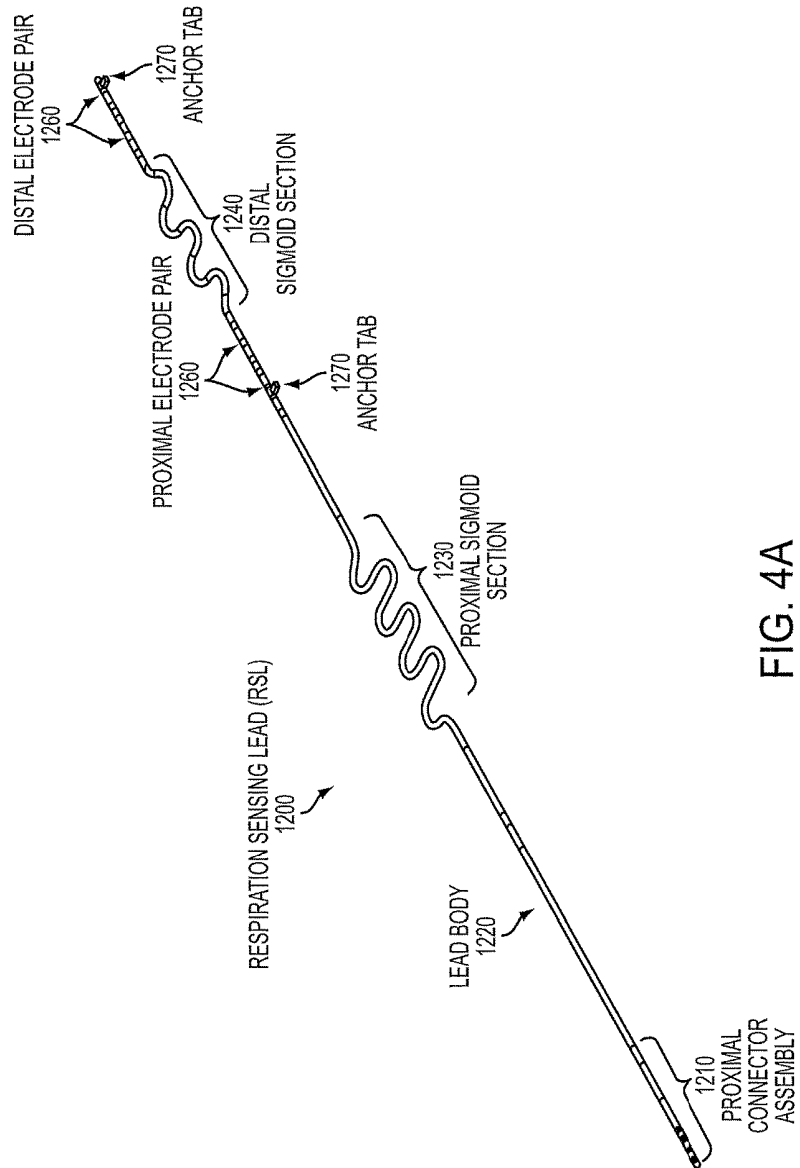

FIG. 4A

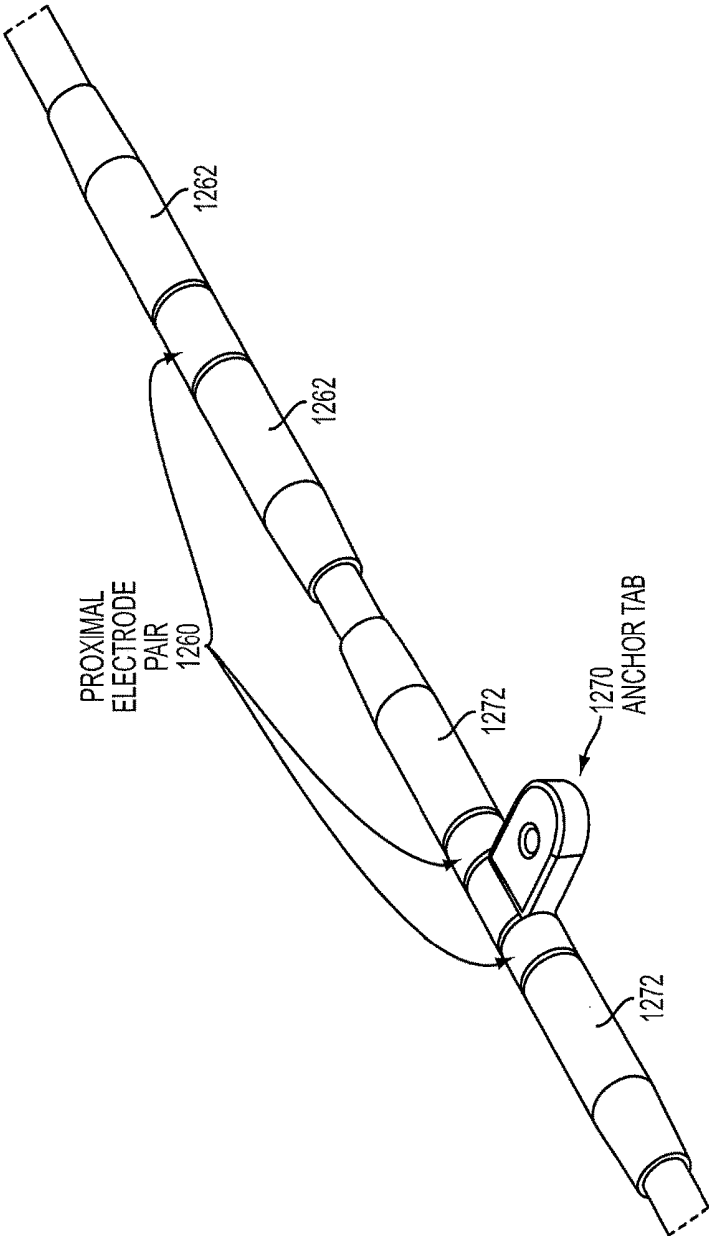

FIG. 4B

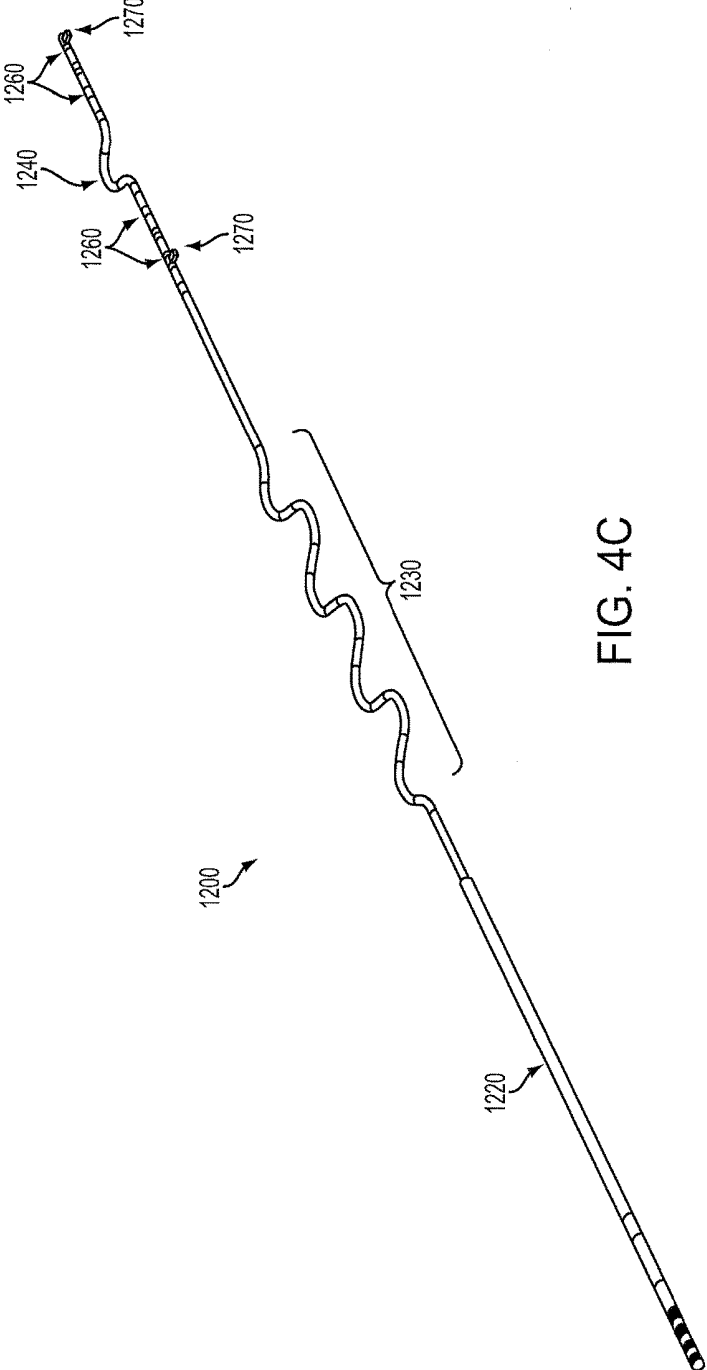

FIG. 4C

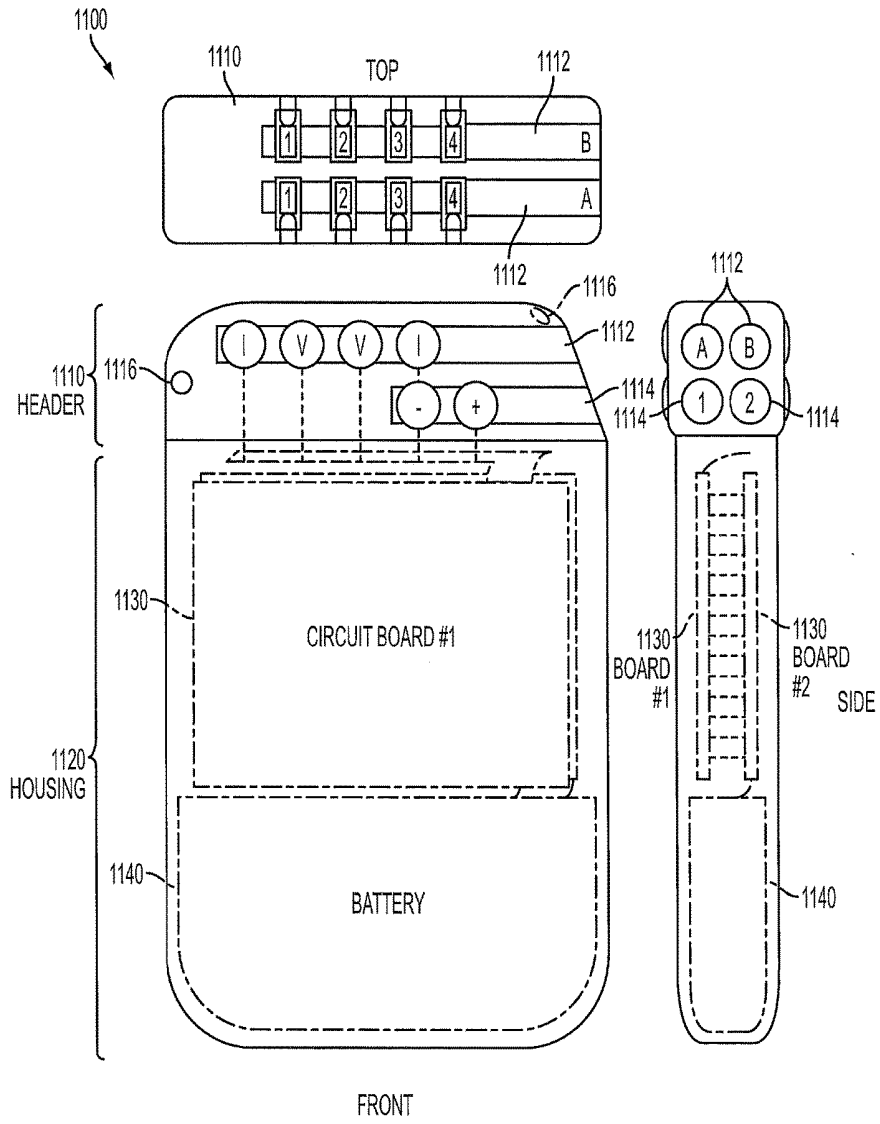

FIG. 5A

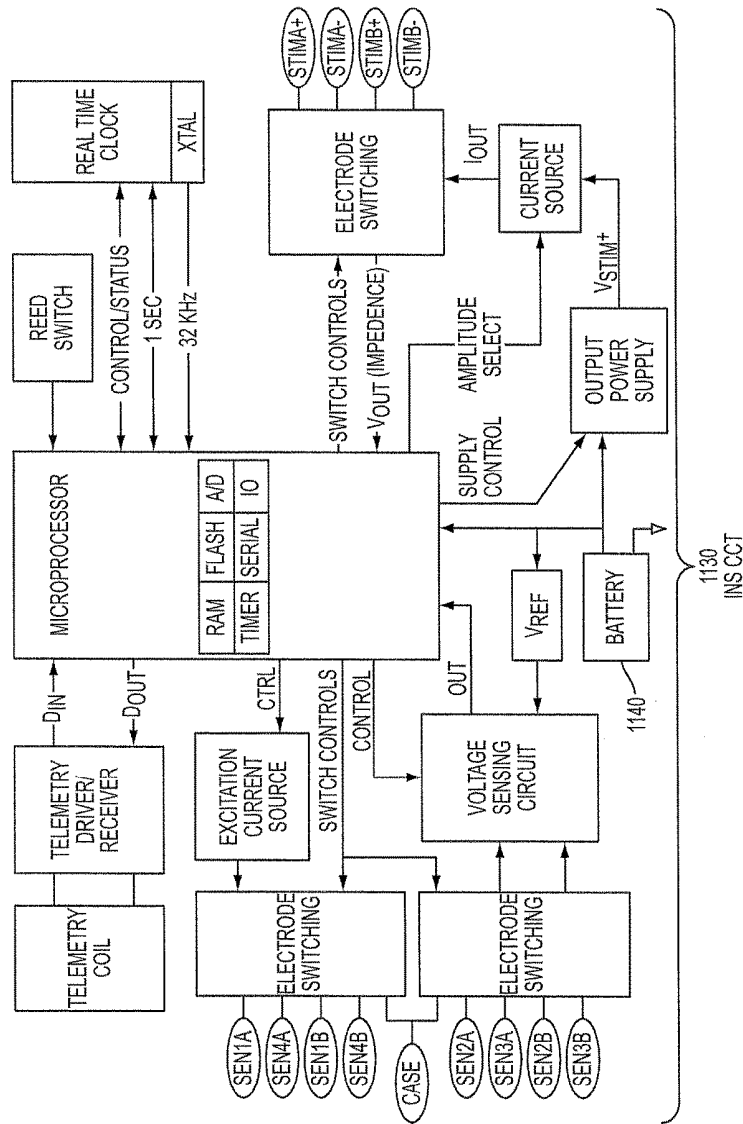

FIG. 5B

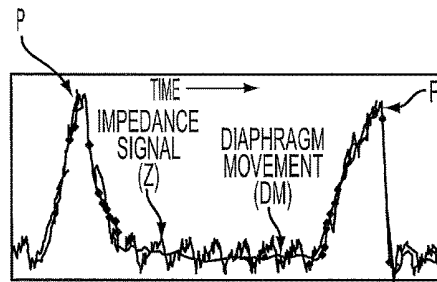

FIG. 6A

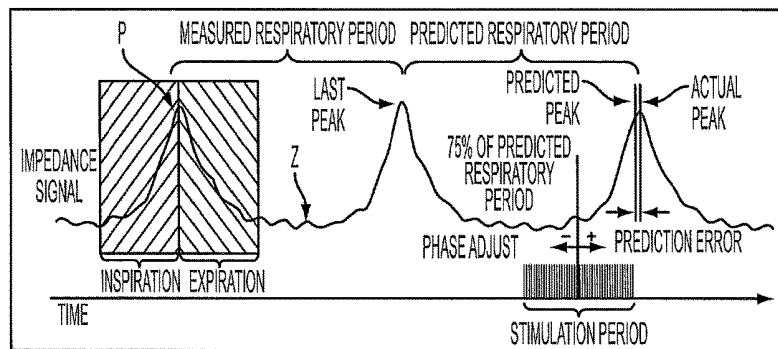

FIG. 6B

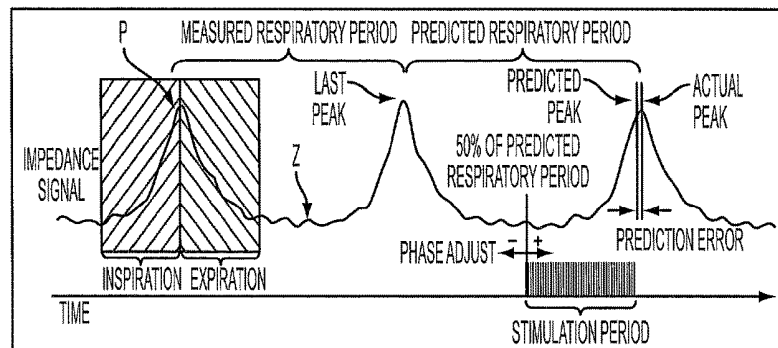

FIG. 6C

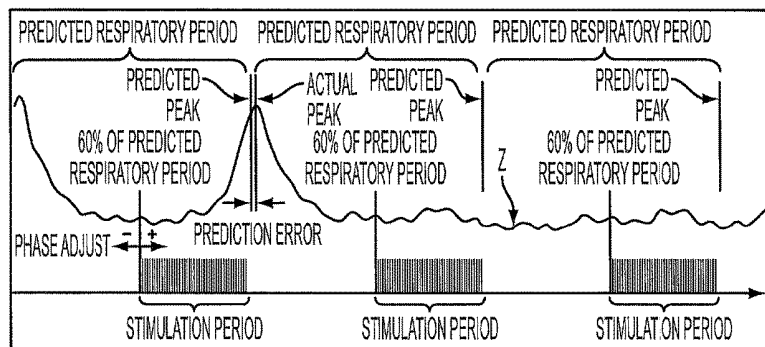

FIG. 6D

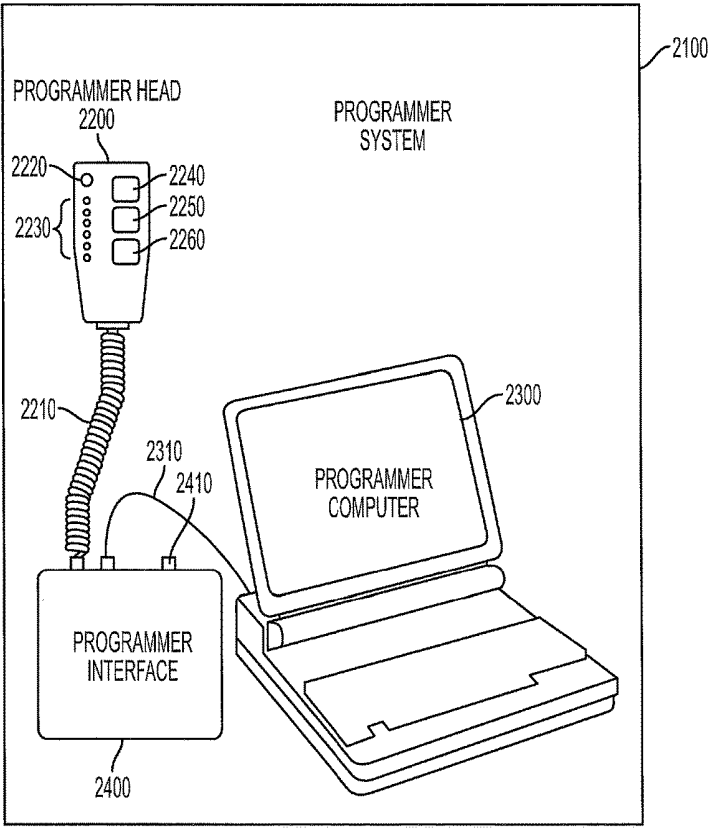

FIG. 7A

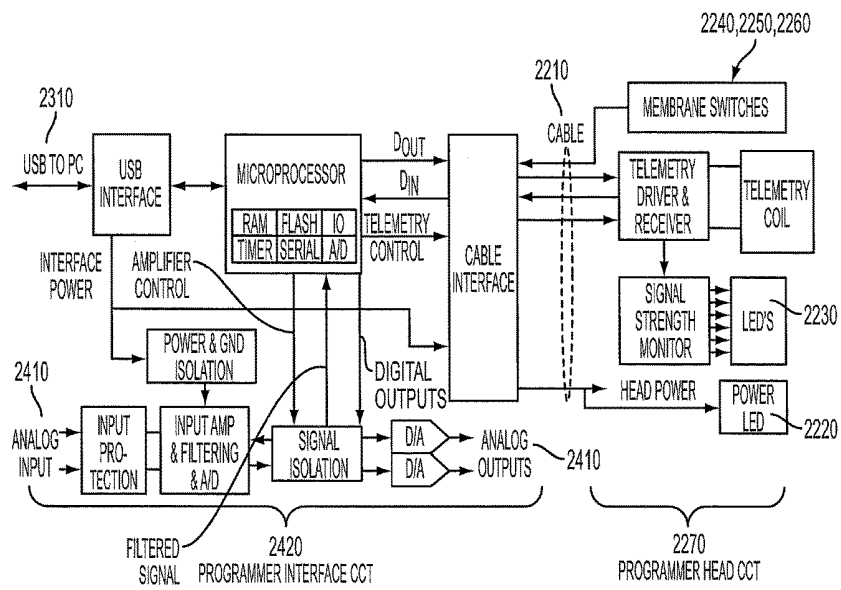

FIG. 7B

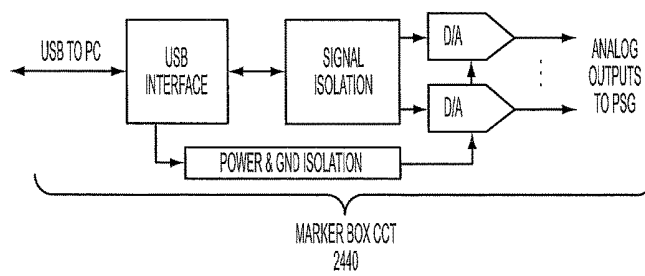

FIG. 7C

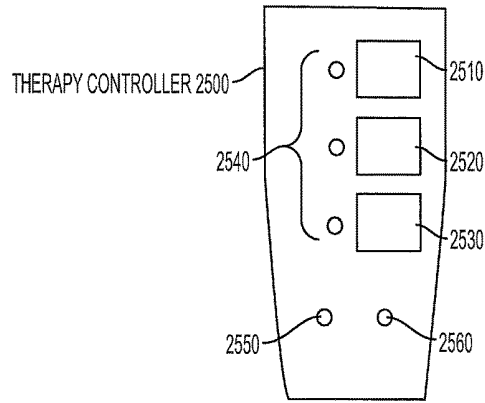

FIG. 8A

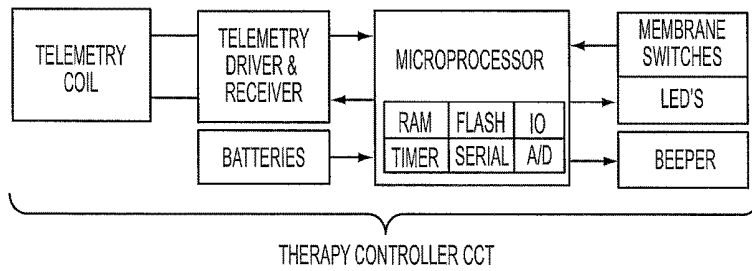

FIG. 8B

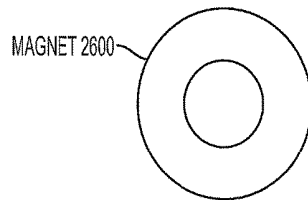

FIG. 9

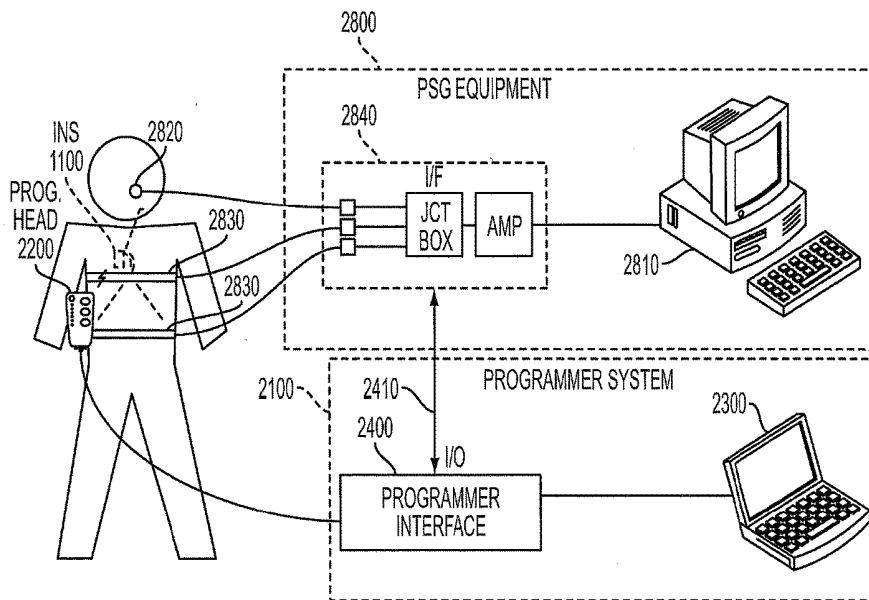

FIG. 10A

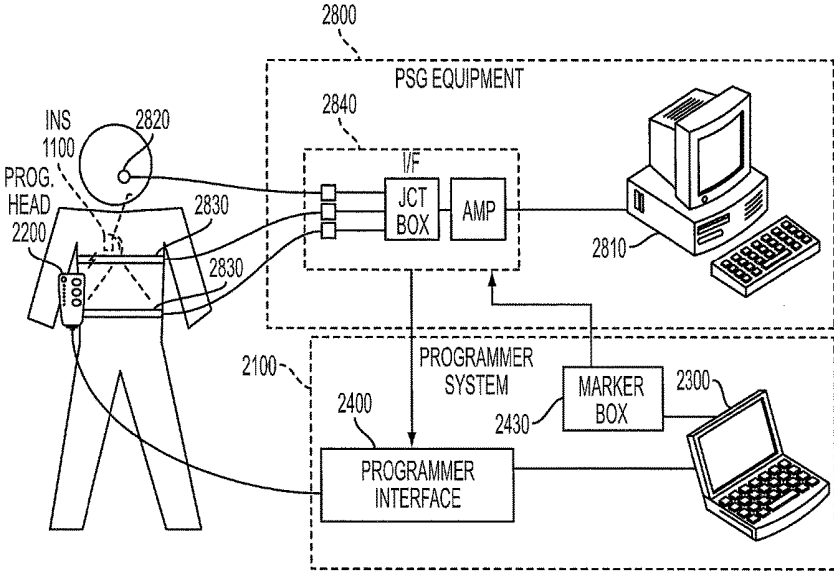

FIG. 10B

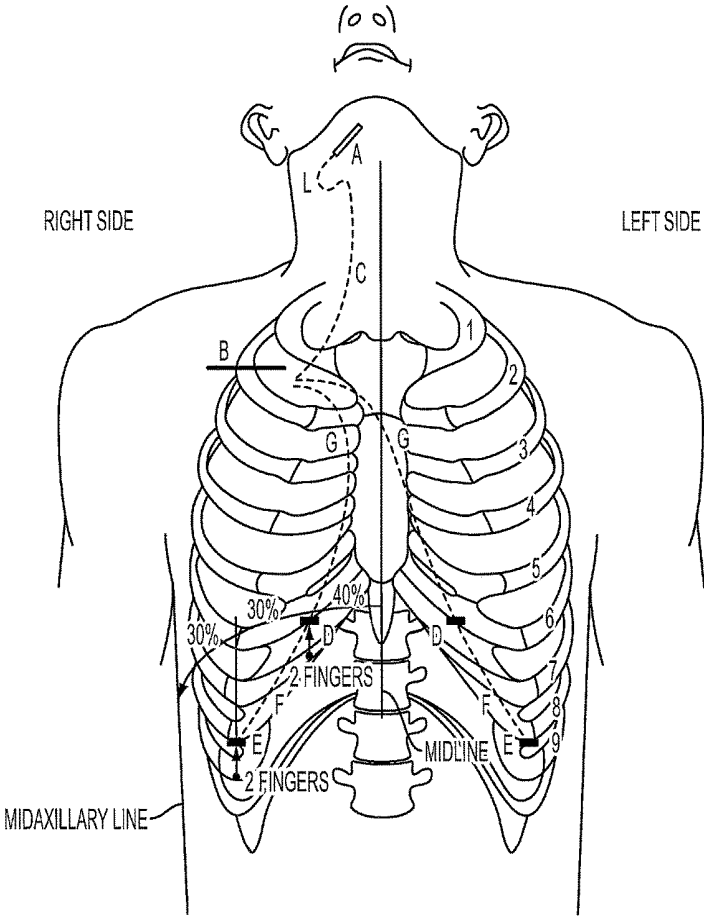

FIG. 11A

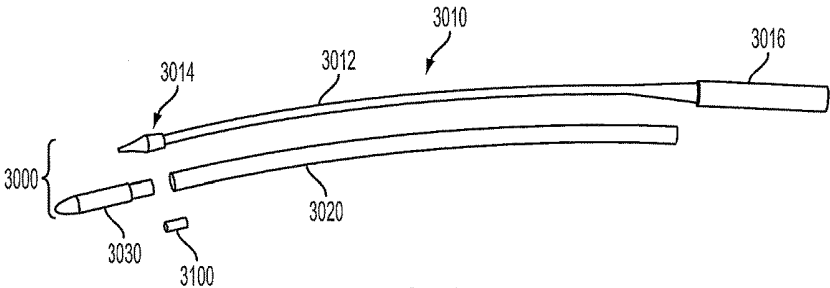

FIG. 11B

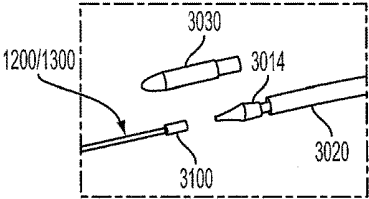

FIG. 11C

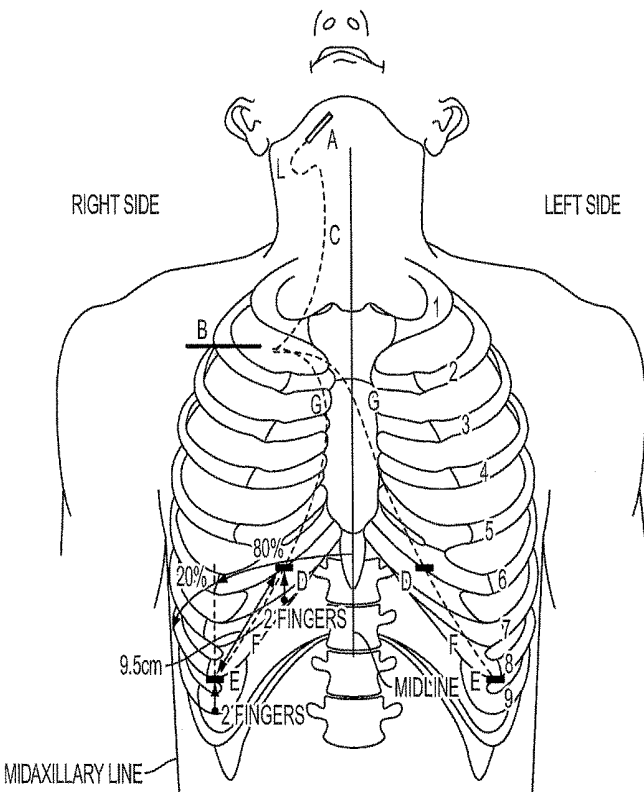
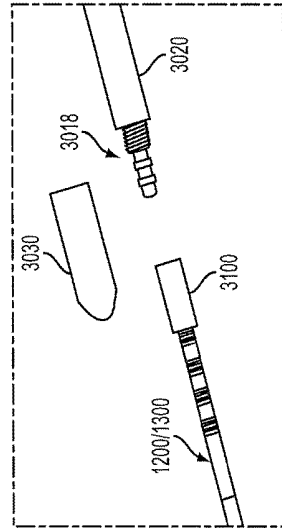
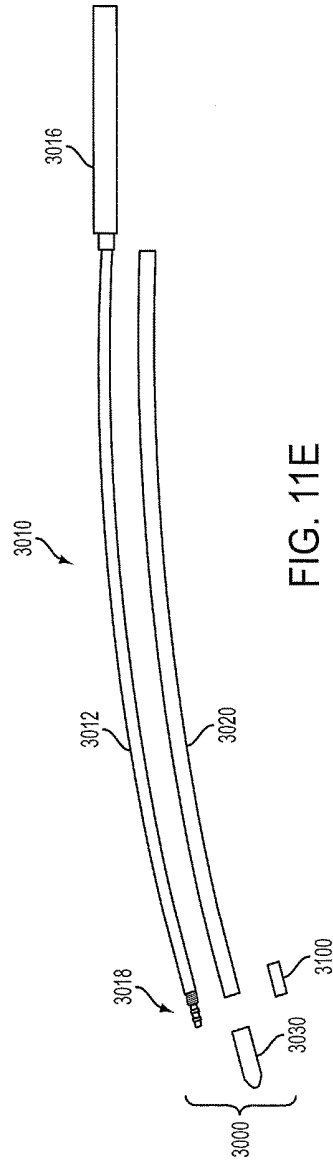

FIG. 11D



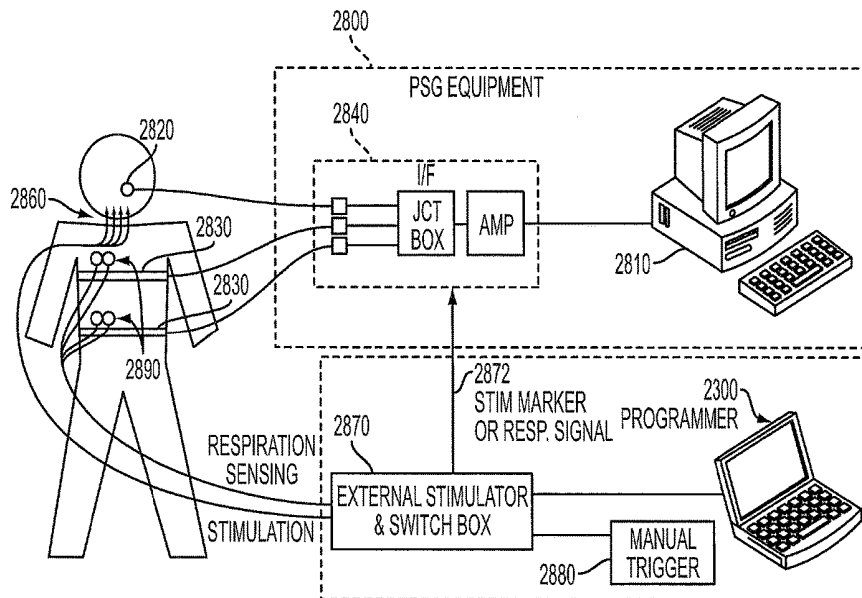

FIG. 12

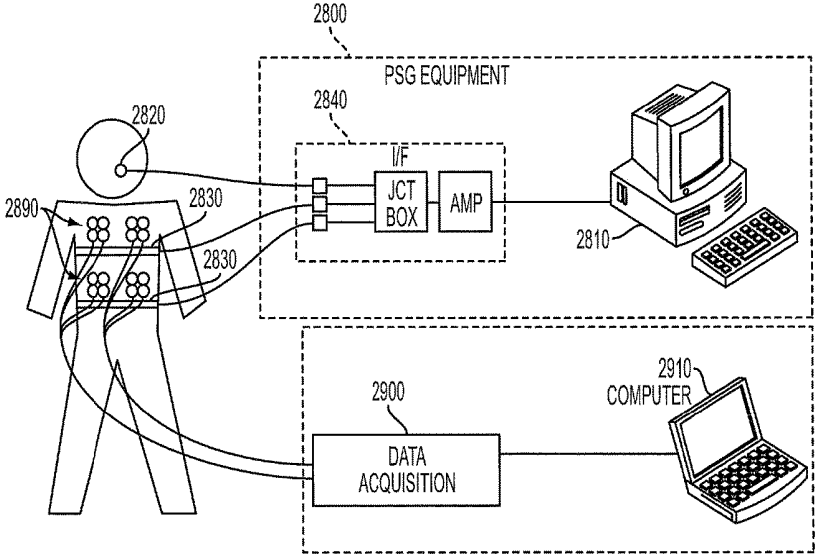

FIG. 13

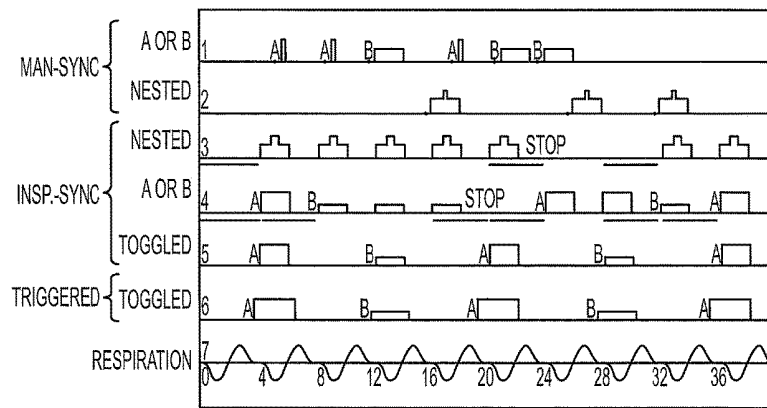

FIG. 14A

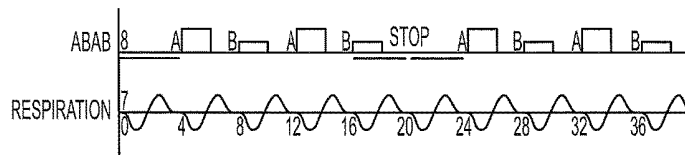

FIG. 14B

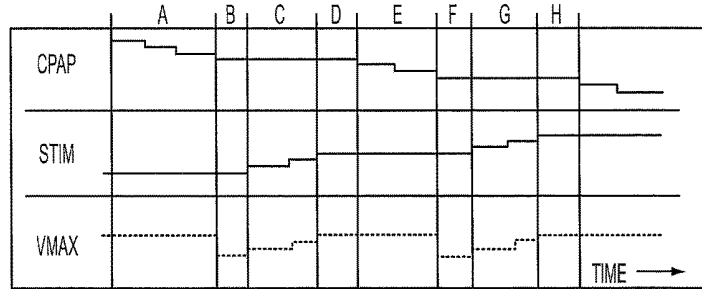

FIG. 15A

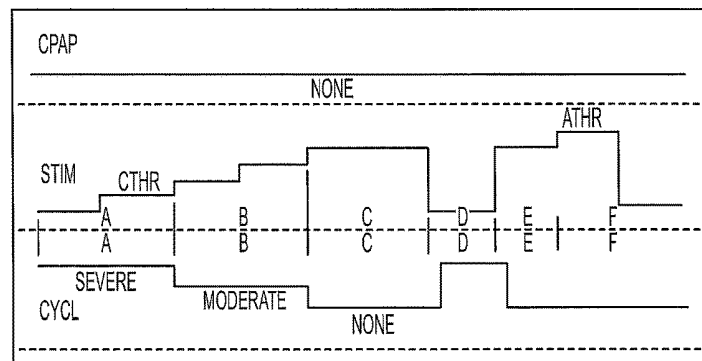

FIG. 15B

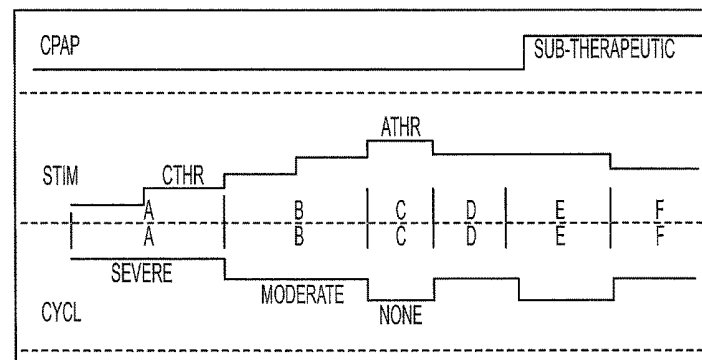

FIG. 15C

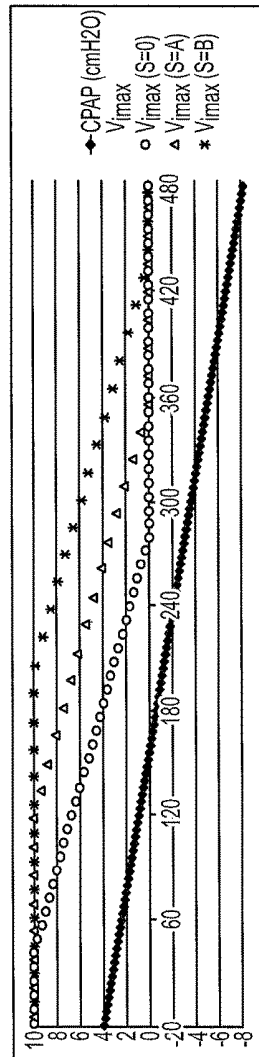

FIG. 16A

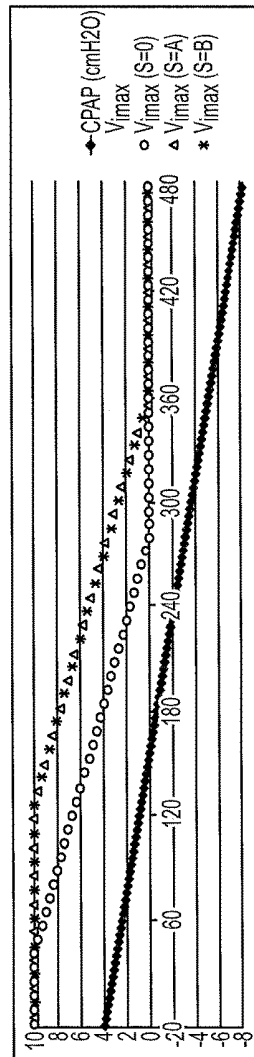

FIG. 16B

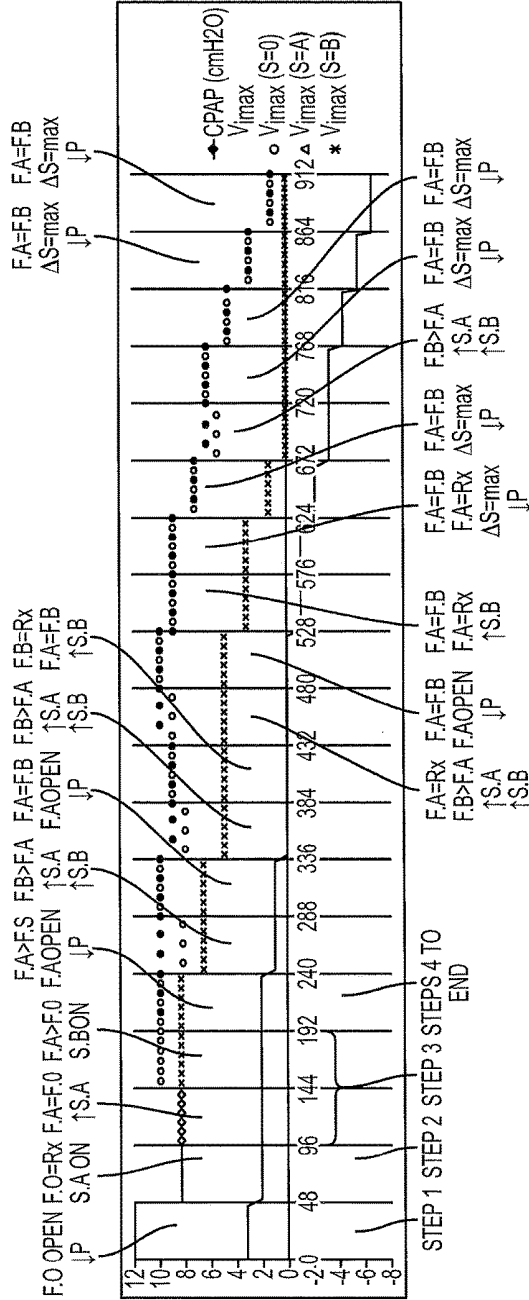

FIG. 17

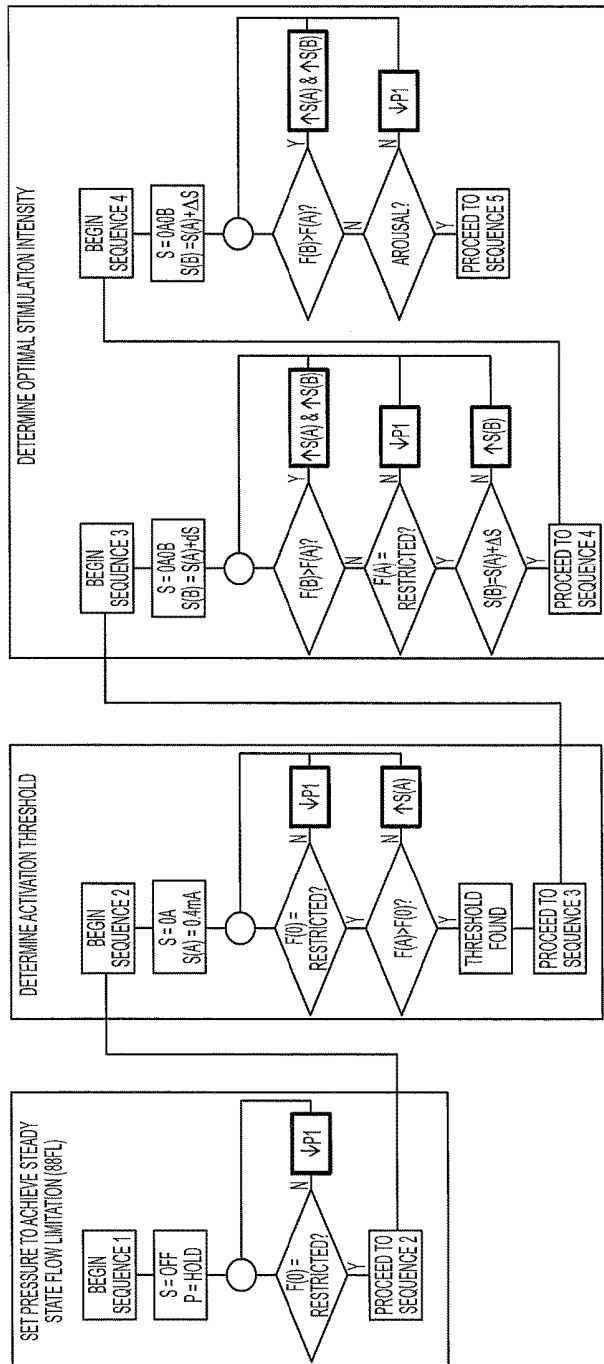

FIG. 18A

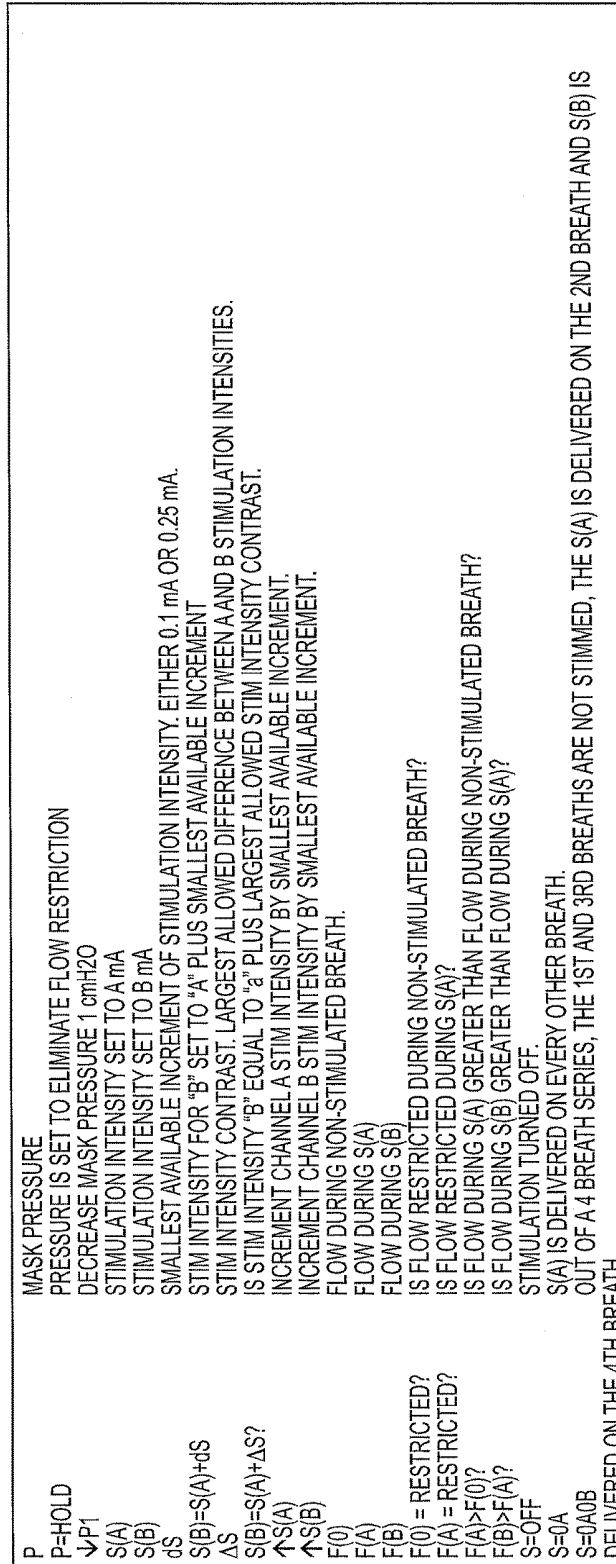

FIG. 18B

**OBSTRUCTIVE SLEEP APNEA TREATMENT
DEVICES, SYSTEMS AND METHODS****CROSS-REFERENCE TO RELATED
APPLICATIONS**

[0001] This patent application claims the benefits of priority under 35 U.S.C. §§ 119 and 120 to U.S. Provisional Patent Application No. 61/204,008, filed on Dec. 31, 2008. This patent application is also related to U.S. patent application Ser. Nos. 11/907,532 and 11/907,533, both filed on Oct. 12, 2007, corresponding to U.S. Patent Application Publication Nos. 2008/0103407 and 2008/0103545, respectively. The entire contents of each of these applications is incorporated herein by reference.

FIELD OF THE INVENTION

[0002] The inventions described herein relate to devices, systems and associated methods for treating sleep disordered breathing. More particularly, the inventions described herein relate to devices, systems and methods for treating obstructive sleep apnea.

BACKGROUND OF THE INVENTION

[0003] Obstructive sleep apnea (OSA) is highly prevalent, affecting one in five adults in the United States. One in fifteen adults has moderate to severe OSA requiring treatment. Untreated OSA results in reduced quality of life measures and increased risk of disease including hypertension, stroke, heart disease, etc.

[0004] Continuous positive airway pressure (CPAP) is a standard treatment for OSA. While CPAP is non-invasive and highly effective, it is not well tolerated by patients. Patient compliance for CPAP is often reported to be between 40% and 60%.

[0005] Surgical treatment options for OSA are available too. However, they tend to be highly invasive (result in structural changes), irreversible, and have poor and/or inconsistent efficacy. Even the more effective surgical procedures are undesirable because they usually require multiple invasive and irreversible operations, they may alter a patient's appearance (e.g., maxillo-mandibular advancement), and/or they may be socially stigmatic (e.g., tracheostomy).

[0006] U.S. Pat. No. 4,830,008 to Meer proposes hypoglossal nerve stimulation as an alternative treatment for OSA. An example of an implanted hypoglossal nerve stimulator for OSA treatment is the Inspire™ technology developed by Medtronic, Inc. (Fridely, Minn.). The Inspire device is not FDA approved and is not for commercial sale. The Inspire device includes an implanted neurostimulator, an implanted nerve cuff electrode connected to the neurostimulator by a lead, and an implanted intra-thoracic pressure sensor for respiratory feedback and stimulus trigger. The Inspire device was shown to be efficacious (approximately 75% response rate as defined by a 50% or more reduction in RDI and a post RDI of ≤ 20) in an eight patient human clinical study, the results of which were published by Schwartz et al. and Eisele et al. However, both authors reported that only three of eight patients remained free from device malfunction, thus demonstrating the need for improvements.

SUMMARY OF THE INVENTION

[0007] To address this and other unmet needs, the present invention provides, in exemplary non-limiting embodiments, devices, systems and methods for nerve stimulation for OSA therapy as described in the following detailed description.

BRIEF DESCRIPTION OF THE DRAWINGS

[0008] It is to be understood that both the foregoing summary and the following detailed description are exemplary. Together with the following detailed description, the drawings illustrate exemplary embodiments and serve to explain certain principles. In the drawings:

[0009] FIG. 1 is a schematic illustration of a system according to an embodiment of the present invention, including internal (chronically implanted) and external components;

[0010] FIG. 2 is a perspective view of a stimulation lead for use in the system shown in FIG. 1, including a detailed view of the distal end of the stimulation lead;

[0011] FIG. 3A is a detailed perspective view of the cuff of the stimulation lead shown in FIG. 2;

[0012] FIG. 3B is a lateral cross-sectional view of the cuff shown in FIGS. 2 and 3A;

[0013] FIG. 4A is a perspective view of a respiration sensing lead for use in the system shown in FIG. 1;

[0014] FIG. 4B is a detailed perspective view of the proximal electrode pair of the respiration sensing lead shown in FIG. 4A;

[0015] FIG. 4C is a perspective view of an alternative respiration sensing lead for use in the system shown in FIG. 1;

[0016] FIG. 5A shows front, side and top views of an implantable neurostimulator for use in the system shown in FIG. 1;

[0017] FIG. 5B is a schematic block diagram of electronic circuitry for use in the implantable neurostimulator shown in FIG. 5A;

[0018] FIGS. 6A, 6B, 6C and 6D illustrate a bio-impedance signal, the corresponding physiological events, and trigger algorithms for use in the system shown in FIG. 1;

[0019] FIG. 7A is a schematic illustration of the programmer system for use in the system shown in FIG. 1;

[0020] FIGS. 7B and 7C are schematic block diagrams of electronic circuitry for use in the programmer system for shown in FIG. 7A;

[0021] FIG. 8A is a schematic illustration of the therapy controller for use in the system shown in FIG. 1;

[0022] FIG. 8B is a schematic block diagram of electronic circuitry for use in the therapy controller shown in FIG. 8A;

[0023] FIG. 9 is a top view of a magnet for use in the system shown in FIG. 1;

[0024] FIG. 10A is a schematic illustration of an interface of the system shown in FIG. 1 and polysomnographic equipment as may be used in a sleep study for therapy titration or therapy assessment, for example;

[0025] FIG. 10B is a schematic illustration of an alternative interface of the system shown in FIG. 1;

[0026] FIGS. 11A and 11D are anatomical illustrations showing the incision sites and tunneling paths that may be used for implanting the internal components shown in FIG. 1;

[0027] FIG. 11B is a perspective view of a disassembled tunneling tool for use in tunneling the leads of the system shown in FIG. 1;

[0028] FIG. 11C is a detailed perspective view of the assembled tunneling tool shown in FIG. 11B, but with the cap removed to expose the jaws for grasping the lead carrier disposed on the proximal end of a lead;

[0029] FIGS. 11E and 11F illustrate an alternative tunneling tool for use in tunneling the leads of the system shown in FIG. 1;

[0030] FIG. 12 is a schematic illustration of an external stimulator system and polysomnographic equipment as may be used for direct muscle stimulation using fine wire electrodes as a therapy efficacy screening method, for example;

[0031] FIG. 13 is a schematic illustration of a bio-impedance monitoring system using surface electrodes and polysomnographic equipment as may be used as a respiratory sensing screening method, for example;

[0032] FIG. 14A and 14B are charts showing various stimulation output modes of the implantable neurostimulator shown in FIG. 1 as may be used for therapy titration, for example; and

[0033] FIGS. 15A, 15B, 15C, 16A, 16B, 17, 18A and 18B are charts illustrating various therapy titration methodologies.

DETAILED DESCRIPTION OF EXEMPLARY EMBODIMENTS

[0034] The following detailed description should be read with reference to the drawings in which similar elements in different drawings are numbered the same. The drawings, which are not necessarily to scale, depict illustrative embodiments and are not intended to limit the scope of the invention.

[0035] Overall System

[0036] FIG. 1 schematically illustrates a hypoglossal nerve stimulation (HGNS) system 100 comprising internal components 1000 and external components 2000. The HGNS system 100 treats obstructive sleep apnea (OSA) by restoring neuromuscular activity to the genioglossus muscle via stimulation of the hypoglossal nerve (HGN) synchronous with inspiration to mitigate upper airway collapse during sleep. Stimulation is generated by an implantable neurostimulator (INS) 1100, synchronized with inspiration as measured by respiration sensing leads (RSLs) 1200 using bio-impedance, and delivered to the hypoglossal nerve by a stimulation lead (STL) 1300. A programmer system 2100 and a therapy controller 2500 are wirelessly linked to the INS 1100. The programmer system 2100 includes a computer 2300, a programmer interface 2400, and a programmer head 2200. The programmer system 2100 is used by the physician to control and program the INS 1100 during surgery and therapy titration, and the therapy controller 2500 is used by the patient to control limited aspects of therapy delivery.

[0037] The implanted components 1000 of the HGNS system 100 include the INS 1100, STL 1300, and RSLs 1200. The INS is designed to accommodate one or two STLs 1300 and one or two RSLs 1200. One STL 1300 may be used for unilateral implantation and unilateral hypoglossal nerve stimulation. Two STLs 1300 may be used for bilateral implantation on both the right and left hypoglossal nerves to enhance the effects of stimulation. Alternatively, a second STL 1300 may be used as a back-up in the event of

re-operation necessitated by failure or suboptimal placement of the first STL 1300. Similarly, one RSL 1200 may be used for respiration detection, but two RSLs 1200 may be used for enhanced sensing capability or redundancy. Alternatively, a second RSL 1200 may be used as a back-up in the event of re-operation necessitated by failure or suboptimal placement of the first RSL 1200. Port plugs (not shown) may be used to seal the unused ports in the header of the INS 1100. If only one STL 1300 and one RSL 1200 are to be used, the INS 1100 may be simplified to accommodate one of each lead, thus reducing the size and complexity of the INS 1100, as well as increasing battery longevity. For purposes of illustration, not limitation, the INS 1100 is shown with two RSLs 1200 and one STL 1300.

[0038] The implanted components 1000 may be surgically implanted with the patient under general anesthesia. The INS 1100 may be implanted in a subcutaneous pocket inferior to the clavicle over the pectoralis fascia. The distal end of the STL 1300 (cuff 1350) may be implanted on the hypoglossal nerve or a branch of the hypoglossal nerve in the submandibular region, and the proximal end of the STL 1300 may be tunneled under the skin to the INS 1100. The RSL 1300 may be tunneled under the skin from the INS 1100 to the rib cage. The INS 1100 detects respiration via the RSLs 1200 using bio-impedance.

[0039] Stimulation Lead (STL)

[0040] FIG. 2 schematically illustrates the STL 1300 in more detail. The STL 1300 is designed to deliver the stimulation signal from the INS 1100 to the hypoglossal nerve and includes a proximal connector assembly 1310, a main tubular body 1330, and a distal cuff 1350. The main tubular body of the STL includes a sigmoid shaped section 1370 and a distal flexible transition section 1380 proximal of the cuff. The STL may have a nominal outside diameter of 0.062 inches to have minimal cosmetic impact, and an overall length of 17.7 inches (45 cm) (including cuff) to extend from the infraclavicular region (INS) to the submandibular region (hypoglossal nerve) and to accommodate anatomical variation.

[0041] The main tubular body 1330 of the STL 1300 is designed to withstand gross neck movement as well as mandibular movement and hypoglossal nerve movement caused by talking, chewing, swallowing, etc. To survive in this high fatigue environment, the main tubular body 1330 incorporates a highly compliant silicone jacket in the form of a sigmoid, and two conductors 1390 (one for cathode electrodes, one for anode electrodes) each comprising ETFE insulated MP35N multifilament cable disposed inside the jacket in the form of a bi-filar coil (not visible). This design provides high fatigue resistance and three-dimensional flexibility (bending and elongation).

[0042] The proximal connector assembly 1310 is designed to provide a reliable mechanical and electrical connection of the STL 1300 to the INS 1100. It has a number of strain relief elements that enable it to withstand handling during insertion and removal from the INS 1100, as well as adverse conditions encountered when implanted. The connector assembly 1310 includes two in-line stainless steel ring contacts (one for each conductor 1390) and two silicone ring seals. Set screws in the header of the INS 1100 bear down on the contacts, and together with the ring seals, provide a sealed mechanical and electrical connection to the INS 1100. More detailed views of the cuff 1350 are shown in FIGS. 3A and 3B, wherein FIG. 3A schematically illustrates the cuff

1350 in isometric view, and FIG. 3B schematically illustrates the cuff **1350** in cross-sectional view. The cuff **1350** has a hinged oval-shaped silicone body (collectively **1352** and **1354**) to define an oval lumen **1355** that provides secure and gentle retention around the hypoglossal nerve. The cuff **1350** may be designed to fit the nerve very closely to minimize tissue growth between the electrode and nerve. Thus, the cuff may be available in two sizes to accommodate nerves of different diameter: a small size to accommodate nerves having a diameter of up to about 2.5-3.0 mm, and a large size to accommodate nerves having a diameter of up to 3.2-4.0 mm. At 3.0 mm nerve diameter, either size cuff will fit the nerve with minimal open space for tissue in-growth. Using a large cuff on a 2.5 mm nerve allows clearance between the nerve and electrode which promotes capsule formation. This may cause an increase in capture threshold but will not affect safety. Conversely, a small cuff placed on a large nerve minimizes electrode coverage around the nerve and may fall off with swelling. The short side **1352** (e.g., 4.0 mm long) of the cuff body fits between nerve branches and connective tissue on the deep side of the nerve, thereby minimizing nerve dissection. The long side **1354** (e.g., 10.0 mm long) of the cuff body rests on the superficial side of the nerve (where few branches exist) and is connected to the transition section **1380** of the main lead body **1330**.

[0043] A silicone strap **1356** is connected to and extends from the short side **1352** of the cuff body. A silicone top plate comprising an integral base portion **1359** and loop **1358** is attached to and covers the exterior surface of the long side **1354** of the cuff body. The strap **1356** freely slides through the loop **1358**, and wraps around the long side **1354** of the cuff body. The strap **1356** is removed from the loop **1358** for placement of the cuff **1350** around the nerve and reinserted into the loop **1358** to hold the cuff **1350** on the nerve. A mark may be disposed on the strap **1356** of the small size cuff to indicate that the cuff is too small and that a larger size cuff should be used if the mark does not pass through the loop **1358**. The cuff body readily expands along a hinge line **1353** (defined at the junction of the short side **1352** to the long side **1354**) as well as other portions of the cuff **1350** structure. Expansion of the cuff body accommodates nerves of different diameters and nerve swelling after implantation, while the strap **1356** remains in the loop **1358** to retain the cuff **1350** on the nerve. In the event of excess nerve swelling (e.g., >50% increase in nerve diameter) or traction from the lead **1300** (e.g., as may accidentally occur during implantation), the strap **1356** pulls out of the loop **1358** and releases the cuff **1350** from the nerve to minimize the potential for nerve damage.

[0044] The cuff body carries four platinum-iridium electrodes **1360** (e.g., 2.0 mm² exposed area each for small cuff, 3.0 mm² exposed area each for large cuff), with one cathode electrode **1360** on the short side **1352**, another cathode electrode **1360** (not visible) diametrically opposed on the long side **1354**, and two anode electrodes **1360** guarding the cathode electrode **1360** on the long side **1354**. This guarded dual cathode arrangement provides a more uniform electrical field throughout the cross-section of the nerve while minimizing electrical field outside of the cuff. One conductor **1390** may be connected to the cathode electrode **1360** on the long side, to which the other cathode electrode **1360** on the short side is connected by a jumper wire. Similarly, the other conductor **1390** may be connected to the distal anode electrode **1360**, to which the proximal anode electrode **1360**

is connected by jumper wire. With this arrangement, the cathode electrodes are commonly connected to one conductor **1390** and the anode electrodes are commonly connected to the other conductor **1390**.

[0045] With the exception of the metal electrode contacts in the cuff, all external surfaces of the STL **1300** exposed to the body when implanted may comprise implantable grade polymers selected from the following: silicone, and fully cured silicone adhesive. The metal electrode contacts in the cuff may comprise implantable grade platinum-iridium and are secured to the silicone cuff body with silicone adhesive, for example.

[0046] Respiration Sensing Lead (RSL)

[0047] FIGS. 4A and 4B schematically illustrate the respiration sensing lead **1200** in more detail. The respiration sensing lead **1200** is designed to measure bio-impedance and includes a proximal connector assembly **1210**, a main tubular body **1220**, and two distal ring electrode pairs **1260**. The main tubular body **1220** of the RSL **1200** includes a proximal sigmoid section **1230** and a distal sigmoid section **1240** between the electrode pairs **1260**. The RSL **1200** may have a nominal outside diameter of 0.072 inches to have minimal cosmetic impact, and an overall length of 24.3 inches (61.6 cm) unstretched, 32.0 inches (81.3 cm) stretched to extend from the infraclavicular region (where the INS **1100** is implanted) to the right or left rib cage (where the RSLs **1200** may be implanted) and to accommodate anatomical variation.

[0048] The main tubular lead body **1220** of the RSL **1200** is designed to withstand thoracic movement due to flexion, extension, rotation and breathing. To withstand this environment, the main tubular body **1220** may include a flexible silicone jacket formed into two sigmoid sections **1230**, **1240** and four conductors comprising small diameter ETFE insulated MP35NLT wires (not visible) disposed inside the jacket in the form of a quad-filar coil. The proximal sigmoid section **1230** isolates movement of the INS **1100** from the electrode pairs **1260** and accommodates anatomic variations in thoracic length. The distal sigmoid section **1240** allows adjustment in the distance between electrode pairs **1260** and reduces strain applied between the anchor tabs **1270**, which may be secured with sutures to the underlying fascia when implanted. The proximal sigmoid **1230** section may have 3 Y2 wavelengths with a peak-to-peak dimension of approximately 0.94 inches (2.4 cm) and an overall length of 5.5 inches (14.0 cm). The distal sigmoid **1240** section may have 2½ wavelengths with a peak-to-peak dimension of approximately 0.94 inches (2.4 cm) and an overall length of 5.5 inches (14.0 cm).

[0049] The two distal electrode pairs **1260** may comprise four electrodes total, and each may comprise MP35N rings having an exposed surface area of 28.0 mm², for example. As shown in FIG. 4B, tubular strain relief segments **1262** and **1272** may be disposed on the lead body on either side of each electrode **1260**. Where the strain relief segments **1262** and **1272** are adjacent each other, a gap may be provided there between as shown in FIG. 4B or the segments may abut each other to avoid a stress concentration point. The anchor tab **1270** may be disposed over an electrode as shown in FIG. 4B leaving the proximal and distal extremities of the electrode exposed.

[0050] At any given time, the INS **1100** detects impedance along a vector, with each end of the vector defined by one active pair of electrodes **1260**. In each active pair of elec-

trodes **1260**, one electrode delivers a small excitation current, and the other electrode monitors the corresponding change in voltage. The INS **1100** may also act as a current emitting and/or voltage sensing electrode. Changes in impedance are calculated by dividing the change in voltage by the excitation current, which correspond to movement of the diaphragm and lung to produce a signal indicative of respiratory activity.

[0051] The proximal connector assembly **1210** of the RSL **1200** is designed to provide a reliable mechanical and electrical connection of the RSL **1200** to the INS **1100**. It has a number of strain relief elements that enable it to withstand handling during insertion and removal from the INS **1100**, as well as adverse conditions encountered when implanted. The connector assembly **1210** may include four in-line stainless steel ring contacts (one for each conductor) and four silicone ring seals. Set screws in the header of the INS **1100** bear down on the contacts, and together with ring seals, provide a sealed mechanical and electrical connection to the INS **1100**.

[0052] With the exception of the distal electrodes, all external surfaces of the RSL **1200** exposed to the body when implanted may comprise implantable grade polymers selected from the following: silicone, and fully cured silicone adhesive. The distal electrodes may comprise implantable grade MP35N and are sealed to the lead body with silicone adhesive, for example.

[0053] FIG. 4C schematically illustrates an alternative embodiment of the respiration sensing lead **1200**. In this embodiment, the RSL **1200** may have a nominal outside diameter of 0.072 inches to have minimal cosmetic impact, and an overall length of 23.5 inches (59.7 cm) unstretched, 26.5 inches (67.2 cm) stretched. The proximal sigmoid **1230** section may have $3\frac{1}{2}$ wavelengths with a peak-to-peak dimension of approximately 0.94 inches (2.4 cm) and an overall length of 5.5 inches (14.0 cm). The distal sigmoid **1240** section may have $\frac{1}{2}$ wavelength with an amplitude of approximately 1.7 inches (4.4 cm) and an overall length of about 0.5 inches (1.3 cm).

[0054] Implantable Neurostimulator (INS)

[0055] FIG. 5A schematically illustrates the INS **1100** in more detail, including a front view, a top view and a side view. The INS **1100** is similar in certain aspects to commercially available implantable pulse generators and implantable neurostimulators, which may be obtained from suitable manufacturers such as CCC Medical Devices (Montevideo, Uruguay). The INS **1100** generally includes a header **1110** for connection of the STL **1300** and RSLs **1200**, and a hermetically sealed housing **1120** for containing the associated electronics **1130** and battery **1140** (e.g., WGL **9086**).

[0056] The electronic circuitry **1130** contained in the INS **1100** enables telemetry communication with the programmer system **2100** and therapy controller **2500**, detection of respiration via the RSLs **1200**, determination of the trigger point for stimulation, and delivery of a controlled electrical stimulation signal (pulse train) via the STL **1300**. The INS **1100** also records therapy data (device settings, respiration data, stimulation delivery data, etc.).

[0057] The header **1110** may comprise epoxy that is hermetically sealed to the housing **1120**. The housing **1120** may comprise titanium. As mentioned in the context of respiration sensing, the housing **1120** may be used as an electrode for bio-impedance respiration measurement. For example,

the housing **1120** may comprise a combination current emitting and voltage sensing electrode for respiration detection.

[0058] The header **1110** includes four ports: two RSL ports **1112** (labeled “sense” A and B) for receiving the proximal connectors of up to two RSLs **1200** and two STL ports **1114** (labeled “stim” **1** and **2**) for receiving the proximal connectors of up to two STLs **1300**. Each port that is configured to receive a STL **1300** includes two set screws (labeled “-” for cathode and “+” for anode) with associated set screw blocks and seals for mechanical and electrical connection to corresponding contacts on the proximal connector **1310** of the STL **1300**. Similarly, each port that is configured to receive a RSL **1200** includes four set screws (two labeled “I” for current emitting electrodes and two labeled “V” for voltage sensing electrodes) with associated set screw blocks and seals for mechanical and electrical connection to corresponding contacts on the proximal connector **1210** of the RSL **1200**. The header **1110** further includes two suture holes **1116** (only one is visible) for securing the INS **1100** to subcutaneous tissue such as muscle fascia using sutures when implanted in a subcutaneous pocket. As shown, approximate dimensions, component values and component configurations are given by way of example, not limitation.

[0059] The INS **1100** generates the stimulation output for delivery to the hypoglossal nerve by way of the STL **1300**. For this purpose, the INS **1100** has two bipolar stimulation output channels, one channel corresponding to each STL port **1114**, with each channel providing a pulse train of constant current with a frequency range of 20 to 50 Hz, a pulse width range of 30 to 215 μ s, an amplitude range of 0.4 to 5.0 mA, and a stimulation duty cycle range of 41% - 69%, by way of example, not limitation.

[0060] The INS **110** also generates the excitation signal and measures voltage by way of the RSLs **1200** for bio-impedance respiration detection. For this purpose, the INS **1100** also has two respiration sensing channels, one channel corresponding to each RSL port **1112**, with each channel providing a small excitation current (“I”) and measuring voltage (“V”). The excitation signal may comprise a 10 Hz biphasic constant current pulse, with the positive and negative phases of each biphasic pulse having an amplitude of 300 μ A, a duration of 50 μ s, and a charge of 15 nC. Changes in impedance (“Z”) are calculated by dividing the change in measured voltage (“V”) by the excitation current (“I”), which corresponds to movement of the diaphragm, lung, and other structures to produce a signal indicative of respiratory activity.

[0061] With reference to FIG. 5B, a block diagram of an example of the INS circuit **1130** is shown schematically. The INS circuit **1130** utilizes a microprocessor to control telemetry communications with the programmer system **2100**, operating the sensing circuits to monitor respiration via the RSLs **1200**, controlling the delivery of output stimuli via the STLs **1300**, monitoring the magnetically sensitive reed switch and the real-time clock. The microprocessor contains built-in support circuits (RAM, Flash Memory, Analog to Digital (A/D) Converter, Timers, Serial Ports and Digital IO) used to interface with the rest of the INS circuit **1130**. The microprocessors. Two microprocessors communicating via a serial link may be used instead of one microprocessor, with the first microprocessor for telemetry communications, monitoring the magnetically sensitive reed switch and the

real-time clock; and the second microprocessor for operating the sensing circuits and controlling the delivery of output stimuli.

[0062] The telemetry interface circuits consist of a tuned telemetry coil circuit and a telemetry driver/receiver circuit to allow pulse encoded communication between the external programmer system **2100** and the microprocessor. As an alternative to telemetry coils and an inductive link, RF antennae with associated circuitry may be used to establish a RF link to provide for arms-length telemetry. The reed switch provides a means for the INS **1100** to be controlled by using a magnet placed in close proximity thereto. The real-time clock provides the basic time base (32 KHz) for the INS circuit **1130** as well as a clock (year, day, hour, minute, second) which can be used to control the scheduled delivery of therapy. The clock is also used to time-stamp information about the operation of the system that is recorded on a nightly basis.

[0063] The respiratory sensing circuits comprise two main parts: the excitation current source (output) and the voltage sensing circuit (input). As will be described in more detail hereinafter, respiration is detected via the RSLs **1200** using a 4-wire impedance measurement circuit, where an excitation current is driven through a pair of electrodes, and the resulting voltage is measured on a separate pair of electrodes. Electrode switching circuits (one for each RSL **1200**) allows the INS **1100** to monitor one of several different vectors from the two separate 4 electrode RSLs **1200**. The INS housing **1120** may also be used as both an excitation and sensing electrode. The excitation current circuit delivers biphasic pulses of low level (300 μ A) current to the selected electrode pair every 100 ms during sensing. The voltage sensing amplifier circuit synchronously monitors the voltage produced by the excitation current on the selected electrode pair. The resulting output signal is proportional to the respiratory impedance (0.2 Ω to 10 Ω) and is applied to the A/D circuit in the microprocessor for digitization and analysis.

[0064] The stimulation output circuits deliver bursts of biphasic stimulation pulses to either STL **1300**. These bursts may be synchronized to the sensed respiratory waveform. The stimulation output circuits include an electrode switching network, a current source circuit, and an output power supply. The electrode switching network allows selection of the stimulation output channel (pair A or B), each corresponding to a STL **1300**. The electrode switching network also allows for a charge balancing cycle following each stimulation pulse during which the outputs are connected together with no applied output pulse. The timing and polarity of the pulse delivery is provided by control outputs of the microprocessor. The microprocessor selects the amplitude (e.g., 0.5 mA to 5 mA) of the output current from the current source circuit which is applied through the switching network. The output power supply converts battery voltage to a higher voltage (e.g., 5V to 13V) which is sufficient to provide the selected current into the load impedance of the STL **1300**. The microprocessor measures the voltage output from the electrode switching network resulting from the delivered current and the load impedance. The microprocessor divides the output voltage by the output current resulting in a measure of the load impedance (6000 to 25000) which can be an indicator of integrity of the STL **1300**.

[0065] With reference to FIG. 6A, the bio-impedance respiration signal ("Z"), which is generated by dividing the change in measured voltage ("V") by the excitation current ("I"), tracks with diaphragm movement (DM) over time and therefore is a good measure of respiratory activity, and may be used to measure respiratory effort, respiratory rate, respiratory (tidal) volume, minute volume, etc. If the excitation current (I) is constant or assumed constant, then the bio-impedance (Z) is proportional to the measured voltage (V), and thus the voltage (V) may be used as a surrogate for bio-impedance (Z), thereby eliminating the division step. As used in this context, diaphragm movement includes movements and shape changes of the diaphragm and adjacent tissue that occur during normal breathing and during obstructed breathing. The (positive or negative) peak (P) of the impedance signal (Z) corresponds to the end of the inspiratory phase and the beginning of the expiratory phase. If the signal is normal (as shown), the positive peak is used; and if the signal is inverted, the negative peak is used. The beginning of the inspiratory phase occurs somewhere between the peaks and may not be readily discernable. Thus, the impedance signal provides a reliable fiducial (P) for end-inspiration and begin-expiration (also called expiratory onset), but may not provide a readily discernable fiducial for begin-inspiration (also called inspiratory onset). Therefore, algorithms described herein do not rely on begin-inspiration (or inspiratory onset) for triggering stimulation as proposed in the prior art, but rather use a more readily discernable fiducial (P) corresponding to begin-expiration (or expiratory onset) in a predictive algorithm as described below. Other non-predictive (e.g., triggered) algorithms are described elsewhere herein.

[0066] In people without OSA, the hypoglossal nerve usually activates approximately 300 ms before inspiration and remains active for the entire inspiratory phase. To mimic this natural physiology, it is desirable to deliver stimulation to the hypoglossal nerve during the inspiratory phase plus a brief pre-inspiratory period of about 300 ms. As mentioned previously, a reliable fiducial for the beginning of the inspiratory phase may not be available from the impedance signal, and a reliable fiducial for the pre-inspiratory period may not be available either. However, there are reliable fiducials for the beginning of the expiratory phase (peak P) which may be used to trigger stimulation to cover the inspiratory phase plus a brief pre-inspiratory period.

[0067] Accordingly, an algorithm is used to predict respiratory period and determine stimulation trigger time. The predictive algorithm is contained in software and executed by a microprocessor resident in the INS circuitry **1130**, thus enabling the INS **1100** to generate stimulation synchronous with inspiration.

[0068] One example of a predictive algorithm is illustrated in FIG. 6B. In this example, the stimulation period is centered about a percentage (e.g., 75%) of the predictive respiratory period. The predictive algorithm uses historical peak data (i.e., begin-expiration data) to predict the time to the next peak, which is equivalent to the predicted respiratory period. The stimulation period is centered at 75%, for example, of the predicted respiratory time period. Thus, the stimulation trigger point is calculated by predicting the time to the next peak, adding 75% of that predicted time to the last peak, and subtracting $\frac{1}{2}$ of the stimulation period (trigger time=time of last peak+75% of predicted time to next peak- $\frac{1}{2}$ stimulation period). A phase adjustment

parameter (range: -1500 ms to +500 ms, for example) permits the stimulation period to be biased early or late. A default setting (e.g., -500 ms) of the phase adjustment parameter moves the stimulation period early relative to the anticipated start of inspiration.

[0069] Another example of a predictive algorithm is illustrated in FIG. 6C. This example differs for the example illustrated in FIG. 6B in that the stimulation period is initiated (not centered) at a percentage (e.g., 50%) of the predicted respiratory period. However, the two examples have essentially equivalent results for a duty cycle of 50%. As in the prior example, the predictive algorithm uses historical peak data (i.e., begin-expiration data) to predict the time to the next peak, which is equivalent to the predicted respiratory period. The stimulation period may start at 50%, for example, of the predicted time period. Thus, the stimulation trigger point is calculated by predicting the time to the next peak and adding 50% of that predicted time to the last peak (trigger time=time of last peak+50% of predicted time to next peak). A phase adjustment parameter (range: -1500 ms to +500 ms, for example) permits the stimulation period to be biased early or late. A default setting (e.g., -500 ms) of the phase adjustment parameter moves the stimulation period early relative to the anticipated start of inspiration.

[0070] A feature common to the predictive algorithms is illustrated in FIG. 6D. This feature provides a sequence of predicted respiratory periods in case the respiration impedance signal ("Z") is temporarily lost (e.g., due to change in respiratory effort). Until a subsequent respiratory peak is detected, stimulation parameters which are based on the measured respiratory period (e.g., stimulation period) are unchanged. Thus, stimulation timing remains synchronous to the last detected peak.

[0071] The stimulation duty cycle may vary to meet efficacy and safety requirements. Generally, the stimulation duty cycle is used to determine the stimulation period as a percentage of the predicted respiratory period (stimulation period=duty cycle×predicted respiratory period). After a stimulation period is started, stimulation continues until the end of the stimulation period as set by the stimulation duty cycle, or until the next actual peak is detected, whichever occurs first. Note that the result of the algorithm illustrated in FIG. 6B is the same as the result of the algorithm illustrated in FIG. 6C for a stimulation duty cycle of 50%.

[0072] The stimulation duty cycle may be fixed or adaptive. In the fixed mode, the stimulation duty cycle is set using to programmer system 2100 to a fixed value. This fixed value may be increased when the respiratory signal is lost. In adaptive mode, the duty cycle is allowed to vary as a function of a characteristic of respiration. For example, the adaptive duty cycle may increase with an increase in respiratory period variability or with the loss of respiratory signal. Thus, in some instances, the stimulation duty cycle may run above normal (e.g., above 50% to 60%) to achieve a better likelihood of covering the inspiratory phase. Because above normal stimulation duty cycle may result in nerve and/or muscle fatigue if prolonged, it may be desirable to offset above-normal stimulation periods with below-normal stimulation periods to result in a net normal duty cycle. For example, if a X % stimulation duty cycle is defined as normal and the adaptive mode results in a period T1 where the stimulation duty cycle runs Y % more than X %, the above-normal stimulation period may be proportion-

ally offset by a below-normal stimulation period T2 where the stimulation duty cycle runs Z % less than X % to satisfy the equation $Y \times T1 = Z \times T2$. This equation is approximate and may vary slightly depending on the averaging technique used. Other offset methods may be used as an alternative.

[0073] The following stimulation duty cycle parameters are given by way of example, not limitation. In fixed mode, the maximum stimulation duty cycle may be set from 41% to 69% in 3% increments, and the default setting may be 50%. In adaptive mode, the stimulation duty cycle for a respiratory period may vary from 31% to 69% in 3% increments, and the maximum running average may be set to 53%. As mentioned above, the adaptive mode allows the duty cycle to increase with respiratory period variability, for example, and the stimulation duty cycle may run in excess of 53% for a limited period of time, but those periods are proportionally offset by periods where the stimulation duty cycle runs less than 53% (e.g., according to an exponentially weighted moving average). For example, an adaptive duty cycle set to 69% would run at that level for no longer than 5 to 7 minutes before being offset by a lower stimulation duty cycle at 47% to result in a running average of 53%.

[0074] Programmer System

[0075] As shown schematically in FIG. 7A, the programmer system 2100 includes a computer 2300, a programmer interface 2400 and a programmer head 2200. The programmer interface 2400 and programmer head 2200 are similar in certain aspects to commercially available programmers, which may be obtained from suitable manufacturers such as CCC Medical Devices (Montevideo, Uruguay). The programmer head 2200 is connected to the programmer interface 2400 via a flexible cable 2210, and the programmer interface 2400 is connected to the computer 2300 via a USB cable 2310. Cable 2210 may be coiled as shown or straight. The programmer system 2100 wirelessly communicates with the INS 1100 via a wireless telemetry link (e.g., 30 KHz) utilizing an antenna and associated circuitry in the programmer head 2200. The programmer interface 2400 provides analog to digital conversion and signal processing circuitry allowing the computer 2300 to control and program the INS 1100 via the programmer head 2200. The programmer head includes a power indication LED 2220, a signal strength LED array (signal strength to/from INS 1100), an interrogate button 2240 (to download data from INS 1100), a program button 2250 (to upload data/commands to the INS 1100) and a therapy-off button 2260 (to stop therapy/ stimulation output from the INS 1100). The computer 2300 may comprise a conventional laptop computer with software to facilitate adjustment of a variety of INS 1100 parameters, including, for example: stimulation parameters (stimulation pulse amplitude, stimulation pulse frequency, stimulation pulse width, stimulation duty cycle, etc.); respiration sensing algorithm parameters; stimulation trigger/synchronisation algorithm parameters, therapy delivery schedule, and various test functions.

[0076] With reference to FIG. 7B, a block diagram of example circuits 2420/2270 for the programmer interface 2400 and the programmer head 2200 are shown schematically. The programmer interface circuit 2420 is controlled by a microprocessor having a standard set of peripherals (RAM, Flash, Digital I/O, Timers, Serial Ports, A/D converter, etc). The microprocessor communicates with a standard personal computer (PC) 2300 through a Universal Serial Bus (USB) interface. Commands and data are passed from the computer

2300 to/from the microprocessor via the USB interface and cable **2310**. The USB interface also provides DC power for the programmer interface circuit **2420** and the programmer head circuit **2270** via cable **2210**. The microprocessor controls the cable interface leading to the programmer head circuit **2270** via cable **2210**. The programmer head circuit **2270** contains telemetry driver and receiver electronics that interface to the telemetry coil. The telemetry coil is designed to inductively couple signals from the programmer head circuit **2270** to the coil in the INS circuit **1130** when the programmer head **2200** is placed over the INS **110** with the coils aligned. As an alternative to telemetry coils and an inductive link, RF antennae with associated circuitry may be used to establish a RF link to provide for arms-length telemetry. The programmer head circuit **2270** also contains electronics that monitor the signal strength as received from the INS **1100**. The outputs of the signal strength electronics drive display LED's for the user. Another LED indicates that power is available. The programmer interface microprocessor controls and receives analog input signals from an isolated sensor interface. The power and ground for the sensor interface are derived from the USB power input, but provide DC isolation for this circuitry to prevent leakage currents from flowing through any patient connections that may be present at the sensor inputs. The sensor inputs are protected against external high voltages (i.e. defibrillation protection). The sensor input signals are amplified and filtered appropriately for the sensor type. The amplifier gain and filter characteristics may be controlled by microprocessor. The signals to/from the amplifier circuit are DC isolated to prevent leakage currents from flowing through any patient connections that may be present at the sensor inputs. The sensor signals are digitized by the microprocessor and are transmitted through the USB link to the PC along with the telemetered signals from the INS **1100**.

[0077] With reference to FIG. 7C, a block diagram of example circuit **2440** for the marker box **2430** is shown schematically. Generally, marker box **2430** and associated circuitry **2440** replace the D/A circuits and analog outputs **2410** of programmer interface circuit **2420** shown in FIG. 7B providing for the alternative arrangement illustrated in FIG. 10B. The marker box circuit **2440** is separately connected to a Universal Serial Bus (USB) port of the programmer computer **2300** via a USB cable. The USB interface also provides DC power for the marker box circuit **2440** via the USB cable. The power and ground for the marker box circuit **2440** are derived from the USB power input, but provide DC isolation for this circuitry to prevent leakage currents from flowing through any equipment that may be connected to the patient. Analog marker output data signals are transmitted from the PC **2300** to control the digital to analog (D/A) converter outputs. These analog output signals may be connected to standard PSG recording equipment **2800**. Signals from the INS **1100** (such as sensed respiration impedance and stimulation output amplitude) can be represented by these outputs to allow simultaneous recording with other standard PSG signals (flow, belts, EMG/ECG, etc).

[0078] Therapy Controller

[0079] As shown schematically in FIG. 8A, the therapy controller **2500** may be used by the patient to control limited aspects of therapy delivery. The therapy controller **2500** is similar in certain aspects to commercially available patient controllers, which may be obtained from suitable manufacturers such as CCC Medical Devices (Montevideo, Uru-

guay). The therapy controller **2500** houses a battery, an antenna, and associated circuitry (not visible) to control limited aspects of therapy delivery via a wireless telemetry link (e.g., 30 KHz) with the INS **1100**. Therapy is normally set for automatic delivery according to a predefined schedule (set by physician using the programmer during titration) but may also be operated in a manual mode. The therapy controller has a user interface including start button **2510** (to start therapy delivery), a stop button **2520** (to stop therapy delivery) and a pause button (to pause therapy delivery), each with associated LED indicators **2540** which flash when the corresponding button is depressed and illuminate steadily when the command is received by the INS **1100**. The user interface also includes a schedule set LED **2550** that illuminates if a therapy delivery schedule has been programmed, and a contact physician LED **2560** that illuminates in the event of a low battery or a malfunction requiring a physician visit.

[0080] With reference to FIG. 8B, a block diagram of an example circuit for the therapy controller **2500** is shown schematically. The therapy controller circuit **2570** includes a battery powered microprocessor having a standard set of peripherals (RAM, Flash, Digital I/O, Timers, Serial Ports, A/D converter, etc). The microprocessor operates in a low power mode to conserve battery power. The microprocessor controls the telemetry driver and receiver electronics that interface with the telemetry coil. The telemetry coil is designed to inductively couple signals to the INS telemetry coil when aligned. The microprocessor monitors the membrane switches and reacts to switch closures by activating display LED's and initiating telemetry commands to the INS. After communicating with the INS, status information can be displayed to the user. The microprocessor also controls a beeper which can provide audio feedback to the user when buttons are pressed and to indicate the success or failure of communications with the INS.

[0081] Magnet

[0082] As schematically shown in FIG. 9, an annular magnet **2600** may be provided to the patient to deactivate the INS **1100** in the event the therapy controller **2500** is not available or functioning. The magnet **2600** may comprise a permanent annular-shaped magnet made of ferrite strontium material coated with epoxy. The magnet **2600** may produce a strong field of **90** Gauss at 1.5 inches from the surface of the magnet along the centerline of the hole. The magnet **2600** may be used (or carried by) the patient in case of emergency. When temporarily (2 seconds or more) placed over the implanted INS **1100** on the skin or clothing, the magnet **2600** disables current and future therapy sessions. Although therapy sessions are disabled by the magnet **2600**, all other functions of the INS **1100** may remain enabled including telemetry communication with the programmer system **2100** and therapy controller **2500**. Therapy sessions may be re-enabled using the programmer system **2100**. The therapy controller **2500** may also re-enable therapy sessions if the therapy controller **2500** has been authorized by the programmer system **2100** to do so.

[0083] Interface with PSG Equipment

[0084] The programmer interface **2400** may include an input/output (I/O) link **2410** to allow connection to polysomnographic (PSG) equipment **2800** as schematically shown in FIG. 10A. Typical PSG equipment **2800** includes a computer **2810** connected to a plurality of sensors (e.g., airflow sensor **2820**, respiratory effort belts **2830**) via inter-

face hardware **2840**. The I/O link **2410** may be used in a number of different ways. For example, analog data signals from the PSG equipment **2800** may be downloaded to the computer **2300** of the programmer system **2100** to record and/or display PSG data (e.g. airflow) together with therapy data. Alternatively or in addition, digital data signals from the INS **1100** and/or the programmer system **2100** may be uploaded to the computer **2810** of the PSG equipment **2800** to record and/or display therapy data (e.g., stimulation and/or respiration data) together with PSG data. The circuitry corresponding to I/O link **2410** may be incorporated into the programmer interface **2400** as shown in FIG. 10A, or may be incorporated into a separate marker box **2430** as shown in FIG. 10B.

[0085] Synchronizing data from the sensors **2820/2830** of the PSG equipment **2800** with data from the INS **1100** via the programmer system **2100** may be beneficial to facilitate therapy titration and efficacy measurement. Although the programmer system **2100** and the PSG equipment **2800** may be directly connected by I/O link **2410**, transmission delay in each system may result in asynchrony. Data synchronization between the systems may be addressed in a number of different ways. For example, if the delays in each system are relatively fixed and below an acceptable threshold (e.g., 0.5 to 1.0 second), no synchronization step need be taken. If the delays in each system are relatively fixed but above an acceptable threshold (e.g., above 0.5 to 1.0 second), data from the system with less delay may be offset (delayed) by a fixed time value to align with data from the system with more delay. As an alternative, a timing signal (e.g., from a clock signal generator separate from or integral with one of the systems) may be input into the PSG equipment **2800** and programmer system **2100** to allow time stamped data independently collected by each system to be merged and synchronized by post processing.

[0086] Treatment Overview

[0087] FIG. 11A schematically illustrates the incision sites (solid thick lines) and tunneling paths (dotted lines) for implanting the INS **1100**, STL **1300** and RSLs **1200**. The implant procedure may be performed by a surgeon (e.g., otolaryngologist) in a 1-2 hour surgical procedure with the patient under general anesthesia, for example. In general, the implant procedure involves placing the cuff **1350** of the SU **1300** on the hypoglossal nerve via a submandibular dissection, and tunneling the lead body **1330** and sigmoid section **1370** of the STL **1300** subcutaneously down the neck to the INS **1100** in a subcutaneous pocket in the infraclavicular region. From the infraclavicular pocket, the RSLs **1200** may be tunneled subcutaneously toward midline and then laterally along the costal margins.

[0088] After a healing period of a few weeks, the patient returns to the sleep lab where a sleep technician, under the supervision of a certified sleep physician (e.g., pulmonologist), uses the programmer system **2100** to program the INS **1100** (e.g., set the therapy delivery schedule and titrate the stimulus to optimize efficacy during sleep).

[0089] Immediately after the titration visit, the patient may return home and begin use. A therapy delivery session may begin according to the pre-defined therapy delivery schedule, which may be set to coincide with when the patient normally goes to sleep. At the beginning of a therapy delivery session, stimulus may be delayed for a period of time to allow the patient to fall asleep. The therapy delivery session may end according to the pre-defined therapy deliv-

ery schedule, which may be set to coincide with when the patient normally wakes up. The therapy delivery session may be programmed to not exceed eight hours. The patient can use the therapy controller **2500** to adjust limited aspects of therapy delivery. For example, the patient can use the therapy controller **2500** to stop, pause and restart a scheduled therapy session. In addition, the therapy controller **2500** can be used to manually control therapy delivery rather than operate according to a preset schedule. This may be beneficial when the patient has an irregular sleep schedule, for example. In this mode, the therapy controller **2500** can be used by the patient to manually start, stop, and pause a therapy session.

[0090] Surgical Implant. Procedure

[0091] With continued reference to FIG. 11A, the internal components **1000** may be implanted using the following surgical procedure, which is given by way of example, not limitation. Unless specifically stated, the order of the steps may be altered as deemed appropriate. Although the INS **1100** may be surgically implanted on the right or left side, the right side is preferred to leave the left side available for implantation of cardiac devices that are traditionally implanted on the left side. The right side is also preferred for the RSL **1200** (if one RSL is used) to provide a clean respiratory signal that is less susceptible to cardiac artifact than the left side.

[0092] Standard surgical instruments may be used for incisions, dissections, and formation of subcutaneous pockets. Commercially available nerve dissection instruments may be preferred for dissecting the hypoglossal nerve and placing the STL cuff **1350** on the nerve. A tunneling tool **3000**, as schematically shown in FIGS. 11B and 11C, may be used for tunneling the STL **1300** and RSL **1200** leads. The tunneling tool (also referred to as tunneler) **3000** includes a relatively rigid grasper **3010**, a tubular sheath **3020**, and a cap **3030**. The sheath **3020** and cap **3030** are sized to be slid over the grasper **3010**. The cap **3030** may include a radiopaque agent such as barium sulfate loaded at 18% by weight, for example. The grasper **3010** may be formed of stainless steel and includes a shaft **3012**, distal jaws (similar to an alligator clip) **3014**, and a proximal handle **3016**. The jaws **3014** are biased to the closed position and may be used to grasp the proximal end of the RSL **1200** or STL **1300** using the lead carrier **3100** as protection. The lead carrier **3100** may comprise a small polymeric tube with an inside diameter sized to form an interference fit with the proximal end of the RSL **1200** or STL **1330**. The sheath **3020** may comprise a polymeric tube with two open ends, and the cap **3030** may comprise a polymeric tube with one open end and one closed end for blunt dissection. The proximal end of the cap **3030** may include a tapered section to fit into the distal end of the sheath **3020** and form an interference fit therewith. In the embodiment shown in FIGS. 11B and 11C, the sheath **3020** may have an outside diameter of approximately 0.37 inches and a length of about 10.9 inches. The cap may have an outside diameter tapering from approximately 0.37 inches and a length of about 1.7 inches. The shaft **3012** may have a diameter of about 0.19 inches and together with the jaws **3014** may have a length sufficient to fill the length of the sheath **3020** and cap **3030**. The handle **3016** may have a diameter of about 0.5 inches and a length of about 3.0 inches.

[0093] An alternative tunneling tool **3000** is schematically shown in FIGS. 11E and 11F may be used for tunneling the

STL 1300 and RSL 1200. In this embodiment, the tunneling tool 3000 includes a relatively rigid grasper 3010, a tubular sheath 3020, and a cap 3030. The sheath 3020 and cap 3030 are sized to be slid over the grasper 3010. The cap 3030 may include a radiopaque agent such as barium sulfate loaded at 18% by weight, for example. The grasper 3010 may be formed of stainless steel and includes a shaft 3012, distal connector 3018, and a proximal handle 3016. The connector 3018 includes threads that mate with corresponding threads in the cap 3030. The connector 3018 may also include ring bars that form an interference fit with the inside of the lead carrier 3100 for releasable connection thereto. The lead carrier 3100 may comprise a small polymeric tube with an inside diameter sized to form an interference fit with the proximal end of the RSL 1200 or STL 1330. The sheath 3020 may comprise a polymeric tube with two open ends, and the cap 3030 may comprise a polymeric tube with one open end and one closed end for blunt dissection. The proximal end of the cap 3030 includes internal threads to screw onto the connector 3018 and hold the sheath 3020 on the shaft 3012. In the embodiment shown in FIGS. 11E and 11F, the sheath 3020 may have an outside diameter of approximately 0.28 inches and a length of about 12.3 inches. The cap may have an outside diameter tapering from approximately 0.13 inches and a length of about 1.0 inches. The shaft 3012 may have a diameter of about 0.22 inches and may have a length sufficient to fill the length of the sheath 3020. The handle 3016 may have a diameter of about 0.5 inches and a length of about 3.74 inches.

[0094] The patient is prepared for surgery using conventional practice including standard pre-operative care procedures, administration of antibiotics as appropriate, and administration of steroids as appropriate to reduce swelling around the nerve dissection. Because tongue movement must be observed during test stimulation, it is recommended that no long-acting muscle relaxants be used during surgical preparation no muscle relaxants be used during implant. General anesthesia is administered according to conventional practice and the patient is intubated using an endotracheal tube, taking care to position the endotracheal tube so that the tongue is free to protrude during test stimulation.

[0095] The neck is then extended to expose right submandibular region and a sterile field is created around the neck and thorax, taking care to avoid obstructing visualization of the oral cavity (a clear sterile drape over the mouth may be used). By way of a neck incision (A), the hypoglossal nerve is then exposed deep to the submandibular gland. Because the INS 1100 is preferably implanted on the right side to minimize cardiac artifact during respiratory sensing, this dissection is also preferably performed on the right side. The branch of the hypoglossal nerve believed to innervate the genioglossus muscle is then identified and isolated. Confirmation of correct nerve location may be achieved by performing a test stimulation later in the procedure. The identified nerve branch is then circumferentially dissected to accommodate the cuff 1350. The short side 1352 of the cuff 1350 is designed to reside on the deep side of the nerve, and the long side 1354 of the cuff 1350 is designed to reside on the superficial side of the nerve.

[0096] The appropriate sized cuff 1350 is then selected based on the nerve diameter at the intended location for cuff placement. Nerve size may be assessed using reference size (e.g., forceps of known width), a caliper, or a flexible gauge that wraps around the nerve, for example. The cuff 1350 is

then opened and placed around the nerve. The strap 1356 on the cuff 1350 may be used to facilitate placement of the cuff 1350 around the nerve. A curved forceps may be placed under the nerve to grasp the strap 1356 and gently pull the cuff 1350 onto the nerve. The strap 1356 is then placed through the loop (buckle) 1358 on the cuff 1350. The cuff 1350 may be available in two sizes (small and large), and the small cuff may have an indicator mark (not shown) on the strap 1356 that should be visible after insertion through the loop 1358. If the indicator mark is not visible, the small cuff may be too small and should be replaced with a large cuff. The surgeon then verifies that the cuff 1350 is not pulling or twisting the nerve, and that there is contact between the inside of the cuff 1350 and the nerve.

[0097] A test stimulation is then performed to confirm correct positioning of the cuff 1350 on the nerve. To conduct a test stimulation, the proximal end of STL 1300 is plugged into the INS 1100 and the programmer system 2100 is used to initiate a test stimulation signal delivered from the INS 1100 to the nerve via the STL 1300. The test stimulation is performed while observing, for example, tongue movement by direct visual observation, airway caliber by nasal endoscopy, lateral fluoroscopy/cephalogram, etc. Correct placement of the cuff on the nerve may be confirmed by, for example, observing tongue protrusion, an increase in retro-glossal airway caliber, an increase in retro-palatal airway caliber, an increase in stiffness of the anterior and/or lateral walls of the retro-glossal airway with or without an increase in airway caliber, anterior movement with or without inferior movement of the hyoid bone, among others. Incorrect placement of the cuff on the nerve is indicated, for example, when the tongue is observed to retract (posterior movement), a decrease in retro-glossal airway caliber, a decrease in retro-palatal airway caliber, superior movement and particularly unilateral superior movement of the hyoid bone, among others. If necessary, the cuff 1350 may be repositioned at a different location along the length of the nerve to obtain the desired effect. The capture threshold and impedance values are recorded and the STL 1300 is disconnected from the INS 1100. A fascial wrap is then sutured over the cuff on the superficial side of the nerve.

[0098] A strain relief loop (L) in the STL 1300 is then created by arranging approximately 6 cm of the STL sigmoid body 1370 in a C-shape inside a small subcutaneous pocket formed via the neck incision (A) by blunt dissection superficially along the lateral surface of the digastric muscle in a posterior direction.

[0099] A pocket for the INS 1100 is then created by making an incision (B) down to the pectoralis fascia up to 2 finger breadths below the right clavicle. The INS 1100 is preferably implanted on the right side to minimize cardiac artifact during respiratory sensing. Blunt dissection inferior to the incision is used to create a pocket large enough to hold the INS 1100. The pocket should be inferior to the incision (B) such that the incision (B) does not reside over the INS 1100 when later placed in the pocket.

[0100] A tunnel is formed for the STL 1300 using the tunneler 3000 (sheath 3020 and cap 3030 placed over grasper 3010) to tunnel along a path (C) from the infraclavicular INS pocket to the neck incision (A). As shown in FIG. 11C, the lead carrier 3100 is then placed on the most proximal electrical contact of the STL proximal connector 1310. The cap 3030 is removed from the sheath 3020 to expose the jaws 3014 of the grasper 3010 and grab the lead

carrier **3100**. While holding the sheath **3020** in place, the grasper **3010** is pulled proximally to pull back the STL **1300** through the sheath **3020**, taking care not to pull out the C-shaped strain relief or disturb the cuff. If the C-shaped strain relief loop (L) is pulled out, it should be replaced into the small pocket. The grasper **3010** is released from the lead carrier **3100** and the lead carrier **3100** is removed from the STL **1300**. The sheath **3020** is then removed from the body leaving the STL **1300** in place. The neck incision (A) need not be closed at this time, but rather may be closed later in the procedure allowing confirmation that the C-shaped strain relief remains in the small pocket.

[0101] The right RSL **1200** is placed near the right costal margin by making two small incisions (D and E) as shown. The medial incision (D) may be made approximately 40% (+/-5%) of the distance from the midline to the midaxillary line, and approximately two finger breadths superior to the costal margin. The lateral incision (E) may be made approximately halfway between the medial incision (D) and the midaxillary line (i.e., extending from the medial incision (D), approximately 30% (+/-5%) of the distance from the midline to the midaxillary line), and approximately up to two finger breadths superior to the costal margin. Using the tunneler **3000** (sheath **3020** and cap **3030** placed over grasper **3010**), a tunnel (F) is formed from the medial incision (D) to the posterolateral incision (E). The lead carrier **3100** is then placed on the most proximal electrical contact of the RSL **1200** proximal connector **1210**. The cap **3100** is then removed from the sheath **3020** to expose the jaws **3014** of the grasper **3010** and grab the lead carrier **3100**. While holding the sheath **3020** in place, the grasper **3010** is pulled proximally to pull back the RSL **1200** through the sheath **3020**. The grasper **3010** is released from the lead carrier **3100** and the lead carrier **3100** is removed from the RSL **1200**. The sheath **3020** is then removed from the body leaving the RSL **1200** in place. Each suture tab **1270** is secured to the underlying tissue by dissecting down to the muscle fascia adjacent the anchor tabs **1270** on the RSL **1200** and suturing each anchor tab **1270** to the muscle fascia. Permanent sutures are recommended to avoid movement of the RSL **1200** before tissue encapsulation, and braided suture material is recommended for knot retention. The left RSL **1200** is then implanted along the left costal margin in the same manner as described above.

[0102] The right RSL **1200** is then tunneled to the pocket (B) for the INS **1100**. Using the tunneler **3000** (sheath **3020** and cap **3030** placed over grasper **3010**), a tunnel (G) is formed from the infraclavicular pocket to the medial incision (D). The lead carrier **3100** is placed on the most proximal electrical contact of the RSL **1200** proximal connector **1210**. The cap **3030** is then removed from the sheath **3020** to expose the jaws **3014** of the grasper **3010** and grab the lead carrier **3100**. While holding the sheath **3020** in place, the grasper **3010** is pulled proximally to pull back the RSL **1200** through the sheath **3020**. The grasper **3010** is released from the lead carrier **3100** and the lead carrier **3100** is removed from the RSL **1200**. The sheath **3020** is then removed from the body leaving the RSL **1200** in place. The left RSL **1200** is then tunneled to the pocket for the INS **1100** in the same manner as described above.

[0103] The STL **1300** and RSLs **1200** are then connected to the INS **1100**. Since one STL port is not used in this example, a port plug (small silicone cylinder) is inserted into header port STL-2. The RSLs **1200** are plugged into ports

RSL-A and RSL-B, the STL **1200** is plugged into port STL-1 and the set screws are tightened to 1 click using a torque wrench.

[0104] A closed loop test may be performed to confirm proper operation by observation of tongue protrusion in concert with inspiration. The INS **1100** and proximal portions of the leads **1200/1300** are then placed into the infraclavicular pocket, looping the excess lead length beneath or around the INS **1100**. Care should be taken not to pull out the C-shaped strain relief loop (L) in the STL sigmoid lead body **1370** while manipulating the INS **1100** into place. The INS **1100** is then sutured to underlying fascia through both suture holes found in the header **1110** of the INS **1100**. Permanent sutures are recommended for to avoid movement of the INS before tissue encapsulation, and braided suture material is recommended for knot retention. Another system test may be performed at this point. After confirming that the C-shaped strain relief loop (L) is present in small pocket at neck incision, the incisions may be irrigated (optionally with an antibiotic solution) and closed using conventional techniques. After a healing period of approximately one month, the patient may undergo a sleep study to confirm proper operation of the system and to titrate therapy.

[0105] An alternative lead routing schematic is shown in FIG. 11D. In this alternative embodiment, the left and right lateral incision sites E are located 80% of the distance from the midline to the mid-axillary line, up to two finger breadths above the rib costal margin. The medial incision sites D are then located a straight line distance of 9.5 cm medial, up to two finger breadths above the rib costal margin.

[0106] Screening Methods

[0107] As schematically shown in FIG. 12, an external system may be used to conduct a stimulation screening session prior to full implantation wherein the genioglossus muscle (innervated by the hypoglossal nerve) is stimulated with fine wire electrodes (FWEs) **2860** inserted submentally with a needle during an otherwise conventional sleep (PSG) study utilizing PSG equipment **2800**. The FWEs **2860** may be inserted into the genioglossus under the guidance of ultrasound. Stimulation signals may be delivered to the genioglossus muscle by connecting the FWE's **2860** to an external stimulator and switch box **2870**. The external stimulator and switch box **2870** may comprise the INS **1100**, programmer head **2200** and programmer interface **2400** in a common housing, with the stimulation output of the INS **1100** connected to the FWEs **2860** and the sensing input of the INS **1100** connected to skin surface electrodes **2890** for bio-impedance respiration measurement. A stimulation marker output signal **2872** from the external stimulator and switch box **2870** to the PSG equipment **2800** allows stimulation and/or respiration data to be synchronized and merged with PSG data in near real time. The external stimulator and switch box **2870** may include a manually operated switch array to select a single FWE or a combination of FWEs **2860** to deliver a stimulation signal to the genioglossus muscle. With this arrangement, stimulation may be delivered via FWEs **2860** automatically triggered by inspiration measured via skin surface electrodes **2890** or manually triggered via activating a manual trigger switch **2880**. The efficacy of delivering stimulus to the genioglossus muscle may be observed and measured using conventional PSG parameters. Efficacious results may be indicated by a significant reduction in apnea hypopnea index, an increase in flow, a decrease

in critical closing pressure, and/or an increase in airway caliber, for example. Patients that respond adequately to stimulation during the trialing period (“responder”) may receive the implanted device. Perhaps more importantly, patients that do not adequately respond to stimulation during the trialing period (“non-responder”) would not receive the implanted device.

[0108] As schematically shown in FIG. 13, an external system may be used to conduct a respiration screening session prior to full implantation wherein skin surface electrodes are placed on the skin at or near the locations that the respiration sensing electrodes and INS would be implanted. Bio-impedance measurements may be taken during a sleep study to determine if an adequate bio-impedance signal may be obtained. In addition, different locations for the skin surface electrodes may be tested to determine the optimal locations for the respiration sensing electrodes during implantation.

[0109] The stimulation trialing period and the respiration trialing period may be combined into a single study, wherein skin surface bio-impedance measurements may be used to provide closed-loop feedback for stimulating synchronous with inspiration. Patients would then be categorized as responders or non-responders depending on the outcome of the closed-loop study.

[0110] Titrating Methods

[0111] As described previously, after implantation and a healing period of approximately one month, the patient may undergo a sleep (PSG) study to confirm proper operation of the system and to titrate therapy. Titration may utilize the set-up illustrated in FIG. 10, wherein the programmer system 2100 interfaces with the PSG equipment 2800. Titration generally involves (1) selecting an optimal respiratory sensing signal and (2) selecting optimal stimulation signal parameters (e.g., stimulation intensity, respiratory phase adjustment). After titration, therapy efficacy may be measured using standard PSG techniques. For example: a respiratory sensing vector may be selected based on signal strength and stability, reliability; the stimulation amplitude may be selected based on maximum airflow; the phase adjustment may be selected based on stimulation alignment with inspiratory airflow; and therapy efficacy may be evaluated based on elimination of indicia of sleep disordered breathing such as AHI.

[0112] Selecting an optimal respiratory sensing signal involves selecting the best vector defined by two sets of electrodes on the RSL or one set of electrodes on the RSL and the housing of the INS. Selection may be based on maximum signal strength, consistent correlation to inspiration, and maximum signal stability/reliability across sleep stages, body positions, and disordered breathing events, for example. A stable signal has a minimum probability of signal inversion. A reliable signal has a minimum probability of signal loss, and therefore may preferably have a minimum threshold of 0.2 to 0.5 Ohms peak-to-peak, for example. The optimal vector may be selected by incrementally scrolling through all or a preferred subset of possible vectors while sampling the respiration signal and comparing the signal against themselves or predefined thresholds. This scrolling technique may be performed manually (with inputs via the programmer system) or automatically (i.e., programmed). The sampling technique may also be performed manually (visual observation using programmer system) or automatically (i.e., programmed). For practical purposes, the

respiration sensing vector may be evaluated while the patient is awake by having the patient assume different body positions while at resting respiration. Alternatively, the respiration sensing vector may be evaluated while the patient is asleep during different stages of sleep and during different sleep disordered breathing events. The INS is capable of streaming out data from two or more sensing vectors which allows simultaneous comparison. This may be especially useful during titration (body position testing and during sleep study) to minimize chance that evaluation of a given vector is biased by events unrelated to a given vector.

[0113] Selecting optimal stimulation signal parameters (e.g., pulse amplitude, pulse frequency, pulse width, duty cycle, phase adjust, etc.) to optimize efficacy (e.g., as measured by apnea index, hypopnea index, respiratory disturbance index, apnea-hypopnea index, and other obstructive sleep apnea efficacy measures) is preferably performed while the patient is sleeping.

[0114] The adjustable stimulation parameters include pulse frequency (range of 20 to 50 Hz, nominal 40 Hz), pulse width (range of 30 to 215 μ s, nominal 90 μ s), pulse amplitude (range of 0.4 to 5.0 mA, nominal 0.4 mA), duty cycle (range of 41% to 69%, nominal 50%), and phase adjust (range of -1.5 to +0.5 s, nominal -0.5 s). In general, during the stimulation titration process, it is preferable to begin with the lowest settings for pulse width (30 μ s) and amplitude (0.4 mA) at a nominal frequency (40 Hz). If stimulation produces pulsatile (vibrating) contractions, the frequency may be increased to 50 Hz. The pulse width is incrementally increased to 60 μ s, then to nominal (90 μ s), keeping Amplitude at 0.4 mA. With the pulse width set to 90 μ s, amplitude may be iterated according to the process described herein-after. If maximum amplitude is reached and additional intensity is required, the pulse width may be increased while reducing amplitude to minimum (0.4 mA). If maximum pulse width (215 μ s) is reached and additional intensity is required, frequency may be increased while reducing the pulse width to 90 μ s and the amplitude to minimum (0.4 mA).

[0115] An initial step in titrating may involve defining a stimulation operating window, preferably while the patient is awake, defined at its lower limit by a capture threshold and at its upper limit by a comfort threshold. The capture threshold may be defined as the stimulation level at which some indication of a potentially beneficial effect (e.g., gross tongue movement or stiffening) is observed. The comfort threshold may be defined as the stimulation level at which the patient experiences an unacceptable sensation (e.g., pain) while awake or at which the patient partially or completely arouses (e.g., lighter stage of sleep or awake) during sleep. Human subjects have been observed to tolerate (i.e., not arouse) higher stimulation intensities while asleep than they could tolerate while awake. The operating window may be determined at the beginning of the titration sleep study (e.g. during set-up when the patient is awake) to help determine a lower limit or starting point for stimulation (capture threshold) and an upper limit or ending point for stimulation (comfort threshold), between which the stimulation level may be adjusted (e.g., increased) until an efficacious level is found.

[0116] Using the programmer system 2100 to set the stimulation parameters, the stimulation level may be initially set at the lower limit or a percentage (e.g., 50%) of the upper limit, followed by a monitoring period where efficacy is

measured using standard. PSG techniques. After the initial monitoring period, the stimulation level may be incrementally increased, followed by another monitoring period. This may continue in a step-wise fashion up to the upper limit for stimulation or until no significant difference in measured efficacy is discernable between stimulation levels. If no significant difference in measured efficacy is discernable between a lower and higher stimulation level, the lower level may be selected as the desired stimulation dose.

[0117] Because efficacy measures (e.g., apnea-hypopnea index) typically take hours to collect, it may be desirable to create a controlled, flow-limited condition and measure a surrogate parameter (e.g., airflow, critical closing pressure, etc.) in order to complete the step-wise titration process in a reasonable amount of time (e.g., a single or half night sleep study). In addition, because a number of sleep conditions (e.g., sleep stage) change over the course of an all night study, it is beneficial to titrate therapy over a shorter period of time during which sleep conditions are less likely to change as significantly. To create a flow-limited state, the patient may be fitted with a CPAP (continuous positive airway pressure) device comprising a blower connected via a hose to a mask (incorporating a airflow meter such as a pneumotachometer) placed over the patient's nose and/or mouth. The CPAP device may have the capability to deliver variable pressure down to approximately 0 cm H₂O or lower, in increments of 0.10 cm H₂O or less, for example. Such a CPAP device is also called a P device for its ability to assist in making critical closing pressure measurements of the upper airway using techniques developed by Schwartz et al. The airway in people with obstructive sleep apnea will partially or completely occlude during sleep in the absence of adequate positive airway pressure. Thus, adjusting the CPAP pressure below the therapeutic level for a given patient will create a controlled flow-limited condition. Using these techniques, the stimulation intensity level (e.g., current, mA) or other stimulation parameter (e.g., pulse frequency, pulse duration, phase adjustment, etc.) may be titrated by progressively creating greater flow restriction while determining if a change (e.g., an increase) in a stimulation parameter (e.g., intensity) results in an increase in flow.

[0118] With reference to FIGS. 14A and 14B, stimulation may be delivered at different levels, different sequences, and different modes during titration. These stimulation alternatives may also be used for therapy delivery, if desired. In FIG. 14, each burst of stimulation is shown as a positive square wave and corresponds to a train of pulses as described previously. The bottom trace #7 in FIGS. 14A and 14B correspond to a respiratory flow signal wherein the negative portion of the trace corresponds to inspiration, and the positive portion of the trace corresponds to expiration.

[0119] As shown in FIGS. 14A and 14B, stimulation bursts may be delivered at different levels and in different sequences. For example, the stimulation burst may be programmed to be "A or B" (traces #1, #4 and #8), where stimulation is delivered at level "A" until commanded to deliver at level "B", or delivered at level "B" until commanded to deliver at level "A". Stimulation level "A" may correspond to a first selected level and stimulation level "B" may correspond to a second selected level, wherein the first level "A" is different than the second level "B" in terms of amplitude, pulse width and/or duration. Alternatively, the stimulation burst may be programmed to be "nested" (traces

#2 and #3), where the stimulation burst comprises a composite of levels "A" and "B". As a further alternative, the stimulation burst may be programmed to "toggle" (traces #5 and #6) between the same or different level in a repeating pattern (e.g., "AB", "ABAB", "0A0B", "AA", etc.).

[0120] Also as shown in FIG. 14, stimulation may be delivered in three basic modes: manual synchronized; inspiratory synchronized; and triggered. Traces #1 and #2 illustrate manually synchronized stimulation delivery, wherein stimulation is delivered by manually entering a command via the programmer system to initiate stimulation delivery of each burst (e.g., when the user observes or anticipates inspiration on PSG, the user manually enters a command to initiate stimulation delivery). Traces #3, #4, #5 and #8 illustrate inspiratory synchronized stimulation delivery, wherein stimulation is automatically delivered according to an algorithm that predicts the inspiratory phase and initiates stimulation delivery at a desired time relative to inspiration such as at or just prior to inspiratory onset. Trace #6 illustrates triggered stimulation delivery, wherein each stimulation burst is initiated and terminated by a fiducial of the respiratory signal (e.g., positive peak, negative peak, cross-over point, etc.) which may or may not correspond to a physiological event (e.g., inspiratory onset), and which may or may not incorporate a fixed delay. Thus, in triggered mode, the stimulation burst is initiated by a fiducial and terminated by the next occurrence of the same fiducial in a repeating pattern.

[0121] The manually-synchronized A or B mode (trace #1) allows the user to program stimulation parameters for two (A & B) separately deliverable stimulation bursts. On user command, a single burst of stimulation is delivered almost immediately corresponding to A's settings, likewise for B. A and B can be defined with unique amplitudes, pulse widths, and durations; but with a common frequency. The dots on trace #1 indicate the time of manual command followed by the delivery of stimulation immediately thereafter.

[0122] The manually-synchronized nested burst (trace #2) allows the user to program stimulation parameters for a nested stimulation burst. On user command, a single burst of stimulation is delivered almost immediately corresponding to the nested burst parameters. The user defines the nested burst parameter by programming stimulation parameters for a primary mode and separately for a secondary mode. The secondary mode is of shorter duration than the primary mode. The secondary mode may be centered on the primary mode as shown, or shifted to the beginning or end of the primary mode. The two modes can be defined with unique amplitudes, pulse widths, and durations; but with a common frequency. The dots on trace #2 indicate the time of command followed by the delivery of stimulation immediately thereafter.

[0123] The inspiratory-synchronous nested mode (trace #3) delivers stimulation bursts synchronous with inspiration as determined by device and therapy delivery algorithm settings and sensed respiratory signal. This mode is similar in function to manually-synchronous nested mode (trace #2) with the following three differences: first, after user command the stimulation burst does not begin immediately but instead is delivered during the next inspiration as predicted by the therapy delivery algorithm; second, the duration of the stimulation burst is not programmed but is instead determined by the therapy delivery algorithm; and third, the nested stimulation burst will continue to be delivered on

every respiratory cycle until stopped. The lines below trace #3 indicate the time window during which a command will cause therapy to begin on the following inspiration.

[0124] The inspiratory-synchronous A or B mode (trace #4) also delivers stimulation bursts synchronous with inspiration as determined by device and therapy delivery algorithm settings and sensed respiratory signal. This mode is similar to the inspiratory-synchronous nested mode (trace #3) except that the stimulation bursts comprise A or B as in the manually-synchronized A or B mode (trace #1). The selected (A or B) stimulation burst will continue to be delivered on every respiratory cycle until the other burst is selected or until stopped. The lines below trace #4 indicate the time window during which a command will cause therapy to begin or change on the following inspiration.

[0125] The inspiratory-synchronous ABAB mode (trace #8) also delivers stimulation bursts synchronous with inspiration as determined by device and therapy delivery algorithm settings and sensed respiratory signal. This mode is similar to the inspiratory-synchronous nested mode (trace #4) except that the stimulation bursts alternate between A or B on each burst. The stimulation bursts will continue to be delivered on every respiratory cycle until stopped. The lines below trace #8 indicate the time window during which a command will cause therapy to begin or end on the following inspiration.

[0126] The inspiratory-synchronous toggle mode (trace #5) also delivers stimulation bursts synchronous with inspiration as determined by device and therapy delivery algorithm settings and sensed respiratory signal. This mode is similar to the inspiratory-synchronous A or B mode (trace #4) except that the stimulation bursts are toggled. As shown, the toggled stimulation burst sequence comprises OAOB (i.e., no stimulation, stimulation level A, no stimulation, stimulation level B), which continue to be delivered on each 4-breath series of respiratory cycles until stopped.

[0127] The triggered toggle mode (trace #6) is similar in function to the inspiratory-synchronous toggle mode (trace #5) except that the stimulation burst sequence OAOB is initiated and terminated by a recurring fiducial of the respiratory signal.

[0128] An example of a stimulation amplitude titration method is illustrated in FIG. 15A. In the illustration, three traces are shown: CPAP (pressure in cm H₂O); STIM (stimulation amplitude in mA); and V_{i,max} (maximum inspiratory nasal airflow in mL/min as measured by pneumotach or other flow sensor). Initially, the stimulation amplitude is set to the capture threshold, and the CPAP pressure is set to an efficacious level for a given patient (typically above 5 cm H₂O and determined in a prior sleep study). In period "A", the CPAP pressure is gradually decreased until a flow restricted state is reached in period "B" as detected by a drop in V_{i,max}. In period "C", the stimulation amplitude is increased while the CPAP pressure remains constant until an unrestricted flow state is reached in period "D" as detected by a rise in V_{i,max}. In period "E", the CPAP pressure is again gradually decreased until a flow restricted state is again reached in period "F" as detected by a drop in V_{i,max}. In period "G", the stimulation amplitude is again increased while the CPAP pressure remains constant until an unrestricted flow state is reached in period "H" as detected by a rise in V_{i,max}. This iterative process is repeated until the CPAP pressure reaches approximately 0 cm H₂O or until no further flow benefit is observed with increasing

stimulation amplitude as shown in period "I". The desired stimulation dose may be set to correspond to the lowest stimulation amplitude required to mitigate restricted flow at a CPAP pressure of approximately 0 cm H₂O or the lowest stimulation amplitude for which there is no further benefit in flow, whichever is lower. In addition, therapy can be adjusted to prevent flow restrictions at a nasal pressure slightly below atmospheric to ensure efficacy under varying conditions that may otherwise compromise airflow (e.g., head flexion, nasal congestion, etc.).

[0129] Another example of a stimulation amplitude titration method is illustrated in FIG. 15B. In addition to the stimulation amplitude titration technique described above with reference to FIG. 15A, stimulation amplitude titration can be done through a different approach that has two parts. The two parts are: with patient awake and with patient asleep. These will henceforth be known as awake titration and sleep titration respectively. During awake titration, the stimulation amplitudes that cause the lowest level of muscle contraction, tongue displacement, and muscle contraction at the threshold of comfort are recorded for the different frequency and pulse width settings.

[0130] This will be followed by a sleep titration, two examples of which are illustrated in FIGS. 15B and 15C. In FIGS. 15B and 15C, three traces are shown: CPAP (pressure in cm H₂O); STIM (stimulation amplitude in mA); and CYCL (cyclic breathing associated with the patient's sleep disordered breathing state). In addition, several points on the STIM trace are indicated: ATHR (the arousal threshold, or the lowest stimulation amplitude that causes arousal); CTHR (the capture threshold, or the lowest stimulation amplitude where muscle contraction is effected). Traces not shown include those of respiratory flow and oxygen saturation level; although these variables are expected to be affected by stimulation. An effect of stimulation on respiratory flow is described with reference to FIG. 15A.

[0131] In FIG. 15B, sleep titration is carried out with the patient at atmospheric pressure and preferably in the supine position. However, this stimulation level titration is expected to be repeated throughout the sleep titration period with the patient in different conditions, including different body positions and sleep stages. After onset of sleep, in region A, the patient is experiencing what to them would be considered severe sleep disordered breathing. Stimulation amplitude is also periodically increased in region A. During these periodic increases the lowest stimulation amplitude that causes muscle contraction is also identified. In region B, stimulation amplitude continues to be periodically increased, which reduces the degree of but does not abolish the sleep disordered breathing that the patient experiences. In region C after continued increase of the stimulation amplitude a level that abolishes the sleep disordered breathing of the patient is achieved. If this stimulation amplitude is reached in conditions considered to be most challenging, then this stimulation level could be considered the therapeutic level. In region D stimulation is turned OFF, which causes the patient to go into sleep disordered breathing. In region E, the therapeutic stimulation level is turned back ON and the patient's sleep disordered breathing is abolished once again. In region F, continued periodic increase of stimulation amplitude leads to levels that cause arousal. The arousal threshold is thus identified. In this titration process, the stimulation level that abolishes the patient's sleep dis-

ordered breathing without causing arousal and with the patient in the most challenging conditions is identified.

[0132] In FIG. 15C, sleep titration is started with the patient at atmospheric pressure. However, if a stimulation level that completely abolishes sleep disordered breathing without causing arousal is not achieved, then some sub-therapeutic CPAP (the patient's therapeutic CPAP will have been identified in a previous sleep study) could be used to complement stimulation for the delivery of therapy. After onset of sleep, in region A, the patient is experiencing what to them would be considered severe sleep disordered breathing. Stimulation amplitude is also periodically increased in region A. During these periodic increases the lowest stimulation amplitude that causes muscle contraction is also identified. In region B, stimulation amplitude continues to be periodically increased, which reduces the degree of but does not abolish the sleep disordered breathing that the patient experiences. In region C, continued periodic increase of stimulation amplitude leads to levels that cause arousal. The arousal threshold is thus identified. Note that, in this example, the stimulation level that causes arousal is reached before the level that completely abolishes sleep disordered breathing could be. In region D, a stimulation level that is just below the arousal threshold is maintained and the patient holds in moderate sleep disordered breathing. In region E, a sub-therapeutic CPAP level that abolishes the patient's disordered breathing is applied. This identifies the level of CPAP that complements stimulation in some patients. In region F, stimulation is either turned down or OFF from the level just below the arousal threshold, leading the patient to go into disordered breathing. In some cases, where the patients' sleep disordered breathing cannot be abolished by stimulation only, some CPAP pressure may be used to complement stimulation. This could help increase the likelihood of CPAP compliance of some patients since the CPAP pressure is reduced. In addition, it could help analyze how far patients are from being completely treated by either stimulation or CPAP.

[0133] Another example of a stimulation amplitude titration method is illustrated in FIGS. 16A and 16B. This method may be carried out over a period of breaths (e.g., 4-10) or very slowly over several minutes (e.g., dozens of breaths to verify that optimal stimulation intensity has been identified). In the illustration, four traces are shown: one trace for CPAP pressure (designated by a solid diamond, pressure in cm H₂O); and three traces for V_{i,max} (maximum inspiratory nasal airflow in mL/min as measured by pneumotach or other flow sensor) for stimulation amplitudes "0", "A" and "B". V_{i,max} at stimulation amplitude "0" (designated by an open circle) corresponds to flow with stimulation off. V_{i,max} at stimulation amplitude "A" (designated by an open triangle) corresponds to flow with stimulation set to a value "A", and V_{i,max} at stimulation amplitude "B" (designated by an asterisk) corresponds to flow with stimulation set to a value "B", where "A" is slightly less than "B". Stimulation is delivered alternately at levels "A" and "B" with intermediate "0" levels (e.g., "0A0B"). Alternatively, stimulation may be delivered alternately at levels "A" and "B" without intermediate "0" levels (e.g., "AB"), which may be advantageous because the sequence may be executed faster and because arousal may otherwise occur due to low flow conditions at stimulation level "0".

[0134] Initially, the CPAP pressure is set to an efficacious level for a given patient (typically above 5 cm H₂O and determined in a prior sleep study). With the stimulation amplitude set to "0" (i.e., stimulation is turned off), the CPAP pressure is gradually decreased while measuring V_{i,max} to obtain a base-line reading when flow is unrestricted (beginning) and subsequently restricted. The stimulation amplitude is then set to alternate between "A" and "B", where "A" is set to the capture threshold and "B" is set slightly higher than "A" (e.g., 0.1-1.0 mA higher). The CPAP pressure is then gradually decreased (or dropped for a short series of breaths and returned to baseline if needed to maintain a passive state) while measuring V_{i,max} to determine the flow at each stimulation level as shown in FIG. 16A. The values of "A" and "B" are incrementally increased and the CPAP pressure is again gradually decreased while measuring flow. This iterative process is repeated until the traces converge as shown in FIG. 16B, demonstrating that no further benefit in flow is realized with an increase in stimulation. The therapy setting may then be set to correspond to the lower stimulation amplitude value ("A") where the traces for "A" and "B" converge. Note that FIGS. 16A and 16B display the case where no arousal occurs during the gradual decrease in CPAP pressure. In practice, it is expected that arousals will occur before the process can be taken to complete conclusion as shown in the Figures. In the event of arousals, the iterative process is repeated based upon convergence of the traces prior to the point of arousal.

[0135] Another example of a stimulation amplitude titration method is illustrated in FIG. 17. FIG. 17 illustrates this method using a stimulation sequence comprising "0A0B", although a stimulation sequence comprising "AB" may be used as an alternative. In FIGS. 17 and 18: "F" refers to peak inspiratory flow; "F.0" refers to flow with no stimulation; "F.A" refers to flow with stimulus intensity "A"; "F.B" refers to flow with stimulus intensity "B"; "OPEN" indicates that the airway is open, with no flow limitation; "Rx" indicates that the airway is restricted (steady state flow limitation); "↑S.A" (or "↑S.B") indicates that the intensity of stimulus "A" (or "B") should be increased; "↓P" indicates that CPAP (nasal) pressure should be reduced; "ΔS" is the difference between stimuli A and B; and "ΔS=max" is when stimulus "B" is the maximum difference in intensity from stimulus "A" that will be tested (1.0 mA is recommended for this value).

[0136] Step 1 (holding pressure) in this method involves adjusting CPAP (nasal) pressure to the lowest holding pressure where maximum inspiratory flow (V_{i,max}) is not limited, and recording various data. Step 2 (attain oscillation/steady state flow limitation) involves reducing CPAP (nasal) pressure until flow oscillation occurs, recording data, increasing CPAP (nasal) pressure until oscillations cease, thereby achieving steady-state flow limitation (SSFL), and recording data. Step 3 (activation threshold, defined as lowest stimulation intensity with a measurable effect on flow) involves selecting triggered toggled stimulation mode 0A0B with stimulation amplitude level A=stimulation amplitude level B=0.4 mA, and pulse width=30 microseconds (if no effect<90 microseconds, increment to 90 microseconds). Then, with stimulation amplitude level A=B, both amplitude levels A and B are incrementally increased until flow differs between stimulated breaths (level=A=B) and non-stimulated breaths (level=0). If necessary, CPAP (nasal) pressure may be adjusted to ensure SSFL during non-

stimulated breaths. Step 4 (optimize stimulation level) involves selecting triggered toggled stimulation mode 0A0B with stimulation amplitude level A=activation threshold (determined in step 3) and stimulation amplitude level B=smallest increment greater than level A, and then executing the following sub-routine:

[0137] (a) While there is a significant difference in $V_{i,max}$ (>10%) between Stim A and B, increase both A and B amplitudes by same amount (0.1mA-0.5mA) until no significant difference in $V_{i,max}$ is observed;

[0138] (b) If Stim A breaths not flow limited, reduce CPAP (nasal) pressure until flow limitation is achieved and return to step (a); else, continue to (c);

[0139] (c) If Max Delta Slim (difference between Slim A and Slim B=1.0 mA, for example) is reached, decrement CPAP (nasal) pressure; else increase Slim B; continue to (d);

[0140] (d) Stop if either the lowest CPAP pressure level to be tested is reached (e.g., atmospheric or sub-atmospheric), or if maximum stimulation intensity of the INS is reached; else return to (a).

[0141] The therapy setting may then be set to correspond to the lower stimulation amplitude value (“A” or “B”) where there is no increase in flow benefit. Optionally an additional margin may be added to the setting (a fixed value or a percentage of the setting, e.g., 10% to 20%) to accommodate changing physiologic conditions.

[0142] FIG. 18A is a flow chart illustrating the method described with reference to FIG. 17. FIG. 18B provides a legend for the flow chart of FIG. 18A.

[0143] From the foregoing, it will be apparent to those skilled in the art that the present invention provides, in exemplary non-limiting embodiments, devices and methods for nerve stimulation for OSA therapy. Further, those skilled in the art will recognize that the present invention may be manifested in a variety of forms other than the specific embodiments described and contemplated herein. Accordingly, departures in form and detail may be made without departing from the scope and spirit of the present invention as described in the appended claims.

1. (canceled)

2. A programmable neurostimulator comprising:

a processor configured to:

deliver a respiratory therapy to a subject;

titrate a stimulation setting of the respiratory therapy while the subject is awake by delivering a first set of stimulation pulses at a plurality of first stimulation setting values between a lower limit defined by a capture threshold corresponding to a beneficial effect of the respiratory therapy and an upper limit defined by a comfort threshold corresponding to an unacceptable sensation experienced by the subject; and

subsequently, while the subject is asleep, repeat the step of titrating the stimulation setting of the respiratory therapy by delivering a second set of stimulation pulses at a plurality of second stimulation setting values, wherein one or more of the plurality of second stimulation setting values is different than one or more of the plurality of first stimulation setting values and the plurality of second stimulation setting values are between the lower limit defined by the capture threshold and a second upper limit defined by a threshold at which the subject is expected to at least partially arouse from sleep.

3. The programmable neurostimulator of claim 2, wherein the processor is configured to repeat the step of titrating the stimulation setting of the respiratory therapy by further subsequently delivering a third set of stimulation pulses at a plurality of third stimulation setting values, wherein one or more of the plurality of third stimulation setting values is different than one or more of the plurality of second stimulation setting values.

4. The programmable neurostimulator of claim 3, wherein the processor is configured to repeat the step of titrating the stimulation setting of the respiratory therapy by further comparing responses of the subject to the second and third sets of stimulation pulses.

5. The programmable neurostimulator of claim 4, wherein the processor is configured to compare the responses of the subject by comparing air flow of the subject responsive to the second and third sets of stimulation pulses.

6. The programmable neurostimulator of claim 5, wherein the processor is further configured to deliver controlled pressure to an airway of the subject while performing at least one of titrating or repeating the step of titrating the stimulation setting of the respiratory therapy.

7. The programmable neurostimulator of claim 6, wherein the controlled pressure creates a flow-limited state.

8. The programmable neurostimulator of claim 3, wherein the processor is configured to deliver the second and third sets of stimulation pulses in a sequence to define a stimulation pattern.

9. The programmable neurostimulator of claim 8, wherein the stimulation pattern comprises at least one of a period of no stimulation, an AB pattern, an ABAB pattern, an 0A0B pattern, or an AA pattern.

10. The programmable neurostimulator of claim 8, wherein the processor is configured to deliver the stimulation pattern in at least one of a manual mode, a synchronized mode, or a triggered mode.

11. The programmable neurostimulator of claim 3, wherein the third set of stimulation pulses comprises a different amplitude than the second set of stimulation pulses.

12. The programmable neurostimulator of claim 2, wherein the processor is configured to titrate the stimulation of the respiratory therapy such that the titrating defines a stimulation level operating window having a capture stimulation level and a maximum comfort stimulation level inclusively between which the programmable neurostimulator is configured to deliver the first set of stimulation pulses; and

wherein the capture stimulation level corresponds to respiratory muscle movement and the maximum comfort stimulation level is greater than the capture stimulation level.

13. The programmable neurostimulator of claim 12, wherein the respiratory muscle movement is at least one of an initial response of the respiratory muscle to a stimulation, a tongue movement, or a tongue stiffening.

14. The programmable neurostimulator of claim 12, wherein the maximum comfort stimulation level corresponds to at least one of a sensation of pain or an inability to sleep.

15. The programmable neurostimulator of claim 12, wherein the processor is configured to deliver the second set of stimulation pulses at a magnitude that is greater than the maximum comfort stimulation level.

16. The programmable neurostimulator of claim 2, wherein the processor is configured to deliver the awake titration by performing at least one of:

- determining a stimulation level operating window;
- determining a stimulation level that causes muscle contraction; or determining a stimulation level that causes subject discomfort.

17. A programmable neurostimulator comprising: a processor configured to:

- deliver a respiratory therapy to a subject;
- identify a stimulation operating window for the respiratory therapy, wherein the stimulation operating window includes a first threshold and a second threshold, wherein the first threshold is defined as a first level of stimulation at which a beneficial response is observed in an upper airway of the subject, and wherein the second threshold is defined as a second level of stimulation greater than the first level of stimulation;

wherein the second threshold comprises an awake level at which the subject experiences an unacceptable sensation while awake and an asleep level greater than the awake level at which the subject is expected to at least partially arouse from sleep; and

wherein the programmable neurostimulator is configured to identify the stimulation operating window for the respiratory therapy by:

titrating a stimulation setting of the respiratory therapy while the subject is awake by delivering successive stimulation bursts until the first threshold and the awake level of the second threshold are identified, wherein at least one of the successive stimulation bursts includes an intensity different than another one of the successive stimulation bursts; and

subsequently repeating the step of titrating the stimulation setting of the respiratory therapy while the subject is asleep by delivering successive stimulation bursts until the asleep level of the second threshold is identified.

18. The programmable neurostimulator of claim 17, wherein the processor is further configured to deliver controlled pressure to an upper airway of the subject while performing at least one of titrating or repeating the step of titrating the stimulation setting.

19. The programmable neurostimulator of claim 18, wherein the controlled pressure creates a flow-limited state.

20. The programmable neurostimulator of claim 17, wherein the beneficial response comprises a muscle contraction.

21. The programmable neurostimulator of claim 17, wherein the unacceptable sensation comprises at least one of pain, arousal from sleep, or inability to sleep.

* * * * *

专利名称(译)	阻塞性睡眠呼吸暂停治疗装置，系统和方法		
公开(公告)号	US20190151656A1	公开(公告)日	2019-05-23
申请号	US16/164551	申请日	2018-10-18
申请(专利权)人(译)	Cyberonics公司，INC.		
当前申请(专利权)人(译)	Cyberonics公司，INC.		
[标]发明人	BOLEA STEPHEN L HOEGH THOMAS B KUHNLEY BRIAN D SUILMANN DALE G PERSSON BRUCE J BECK JOHN P HAUSCHILD SIDNEY F KAPLAN PAULA M HOYHTYA ADAM K TESHAYESUS WONDIMENEH ATKINSON ROBERT E		
发明人	BOLEA, STEPHEN L. HOEGH, THOMAS B. KUHNLEY, BRIAN D. SUILMANN, DALE G. PERSSON, BRUCE J. BECK, JOHN P. HAUSCHILD, SIDNEY F. KAPLAN, PAULA M. HOYHTYA, ADAM K. TESHAYESUS, WONDIMENEH ATKINSON, ROBERT E.		
IPC分类号	A61N1/36 A61B5/053 A61B5/00 A61N1/05		
CPC分类号	A61N1/3601 A61B5/0538 A61N1/36139 A61B5/4818 A61N1/0556 A61N1/3611		
优先权	61/204008 2008-12-31 US		
外部链接	Espacenet USPTO		

摘要(译)

用于治疗阻塞性睡眠呼吸暂停的神经刺激的装置，系统和方法。

