



US 20190117165A1

(19) **United States**

(12) **Patent Application Publication**
ZENG et al.

(10) **Pub. No.: US 2019/0117165 A1**
(43) **Pub. Date: Apr. 25, 2019**

(54) **CORONARY ARTERY DISEASE DETECTION
SIGNAL PROCESSING SYSTEM AND
METHOD**

A61B 5/0402 (2006.01)
H04R 3/04 (2006.01)
H03G 3/30 (2006.01)

(71) Applicants: **Jikang ZENG**, Kanata (CA); **Md
Shahidul ISLAM**, Ottawa (CA); **Jun
ZHOU**, Kanata (CA); **Daniel
LABONTÉ**, Ottawa (CA); **Simon
MARTIN**, Gatineau (CA); **Brady
LASKA**, Arnprior (CA); **Sergey A.
TELENKOV**, Ottawa (CA)

(52) **U.S. Cl.**
CPC *A61B 5/7203* (2013.01); *A61B 7/04*
(2013.01); *A61B 5/7225* (2013.01); *A61B*
5/0402 (2013.01); *H03F 3/45* (2013.01);
H03G 3/30 (2013.01); *A61B 5/6823* (2013.01);
A61B 2562/0204 (2013.01); *H04R 3/04*
(2013.01)

(72) Inventors: **Jikang ZENG**, Kanata (CA); **Md
Shahidul ISLAM**, Ottawa (CA); **Jun
ZHOU**, Kanata (CA); **Daniel
LABONTÉ**, Ottawa (CA); **Simon
MARTIN**, Gatineau (CA); **Brady
LASKA**, Arnprior (CA); **Sergey A.
TELENKOV**, Ottawa (CA)

(57) **ABSTRACT**

An auscultatory sound signal acquired by a recording module is coupled through a high-pass filter having a cut-off frequency in the range of 3 to 15 Hz and subsequently filtered with a low-pass filter, and optionally subject to variable-gain amplification under external control—via a USB or wireless interface—of an associated docking system, responsive to the resulting processed auscultatory sound signal. A sound generator in the docking system generates an associated test signal having an integral number of wavelengths for each of a plurality of frequencies. The test signal is applied to a corresponding auscultatory sound-or-vibration sensor to test the integrity thereof. Resulting sound signals recorded by the recording module are analyzed using a Fourier Transform to determine sensor integrity.

(21) Appl. No.: **16/166,104**

(22) Filed: **Oct. 21, 2018**

Related U.S. Application Data

(60) Provisional application No. 62/575,364, filed on Oct. 20, 2017.

Publication Classification

(51) **Int. Cl.**
A61B 5/00 (2006.01)
A61B 7/04 (2006.01)

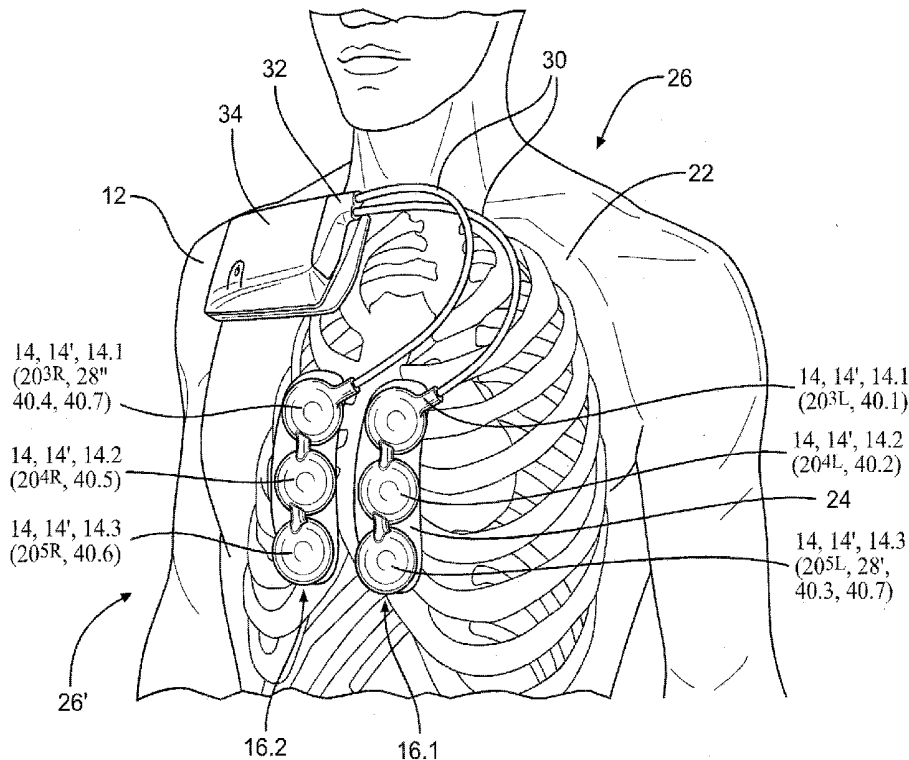

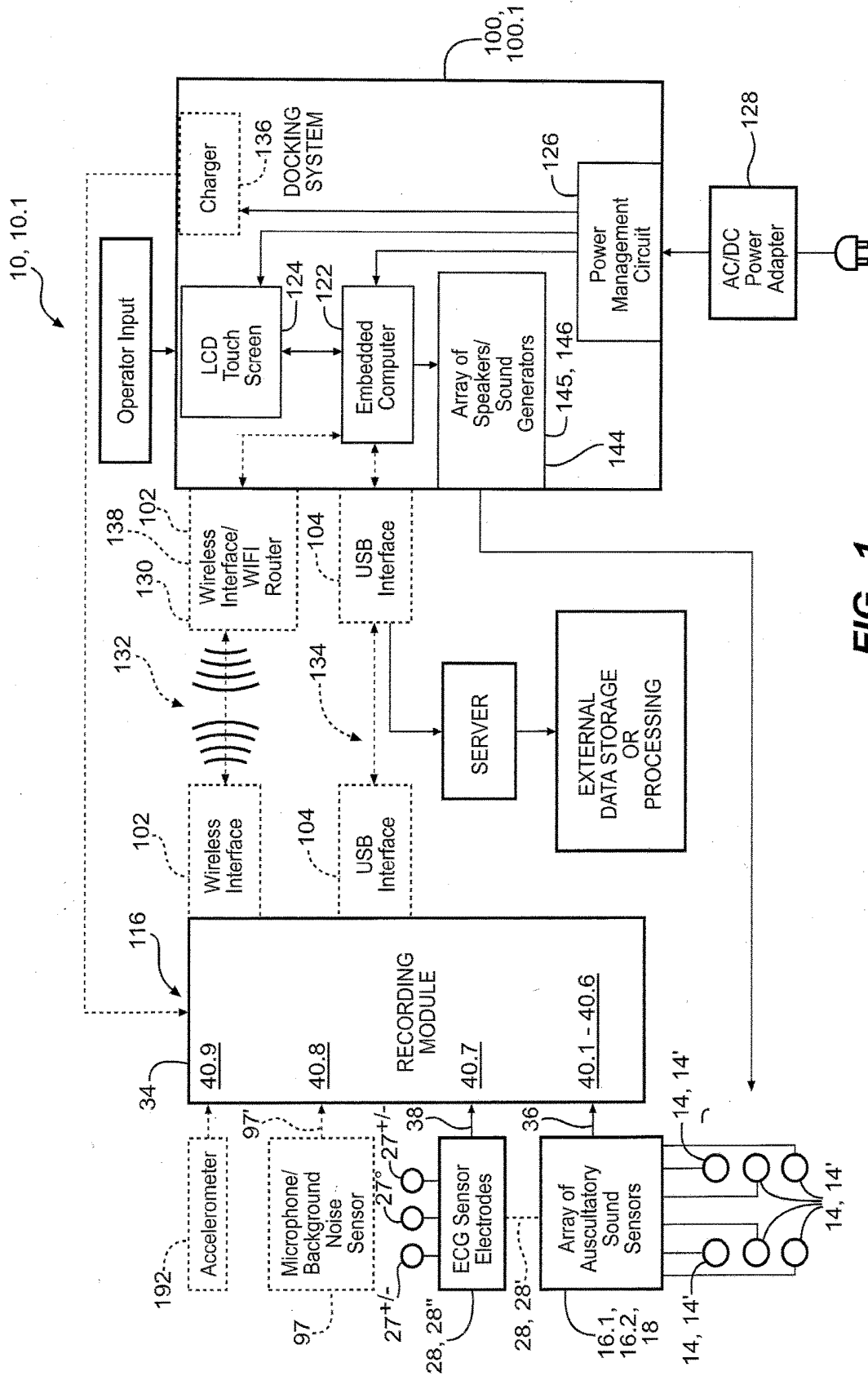

FIG. 1

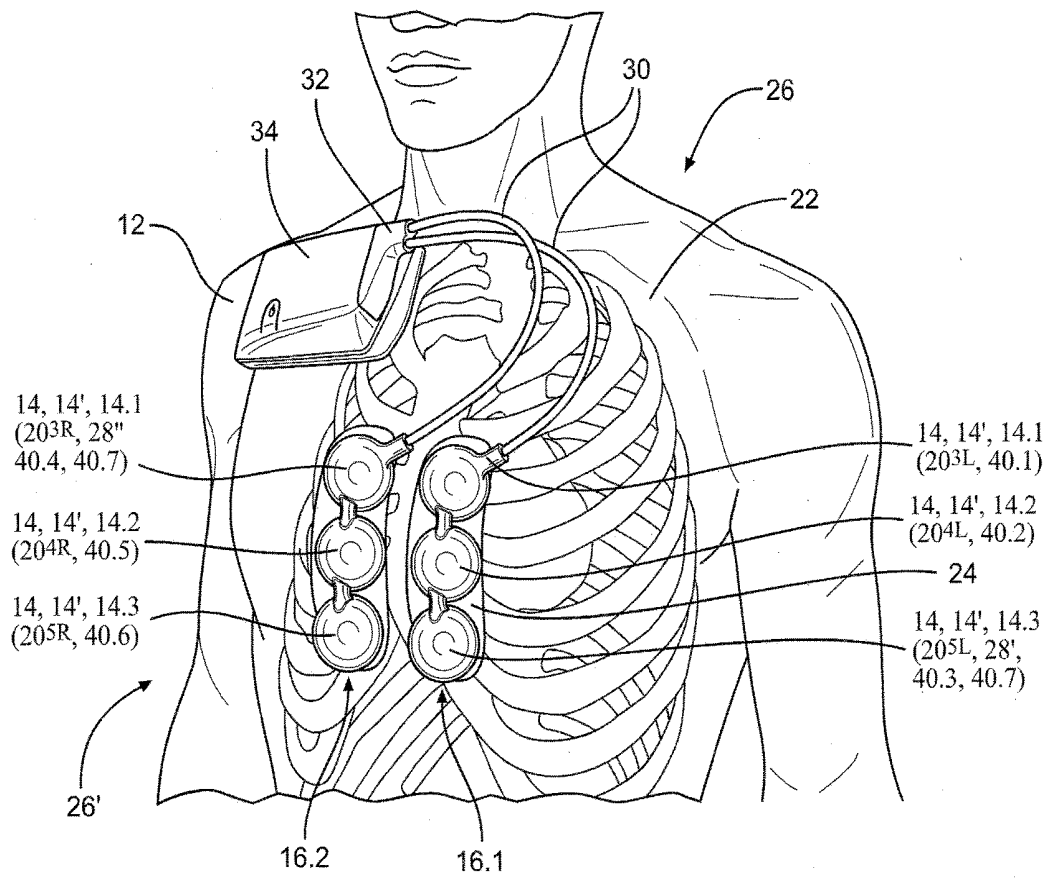

FIG. 2a

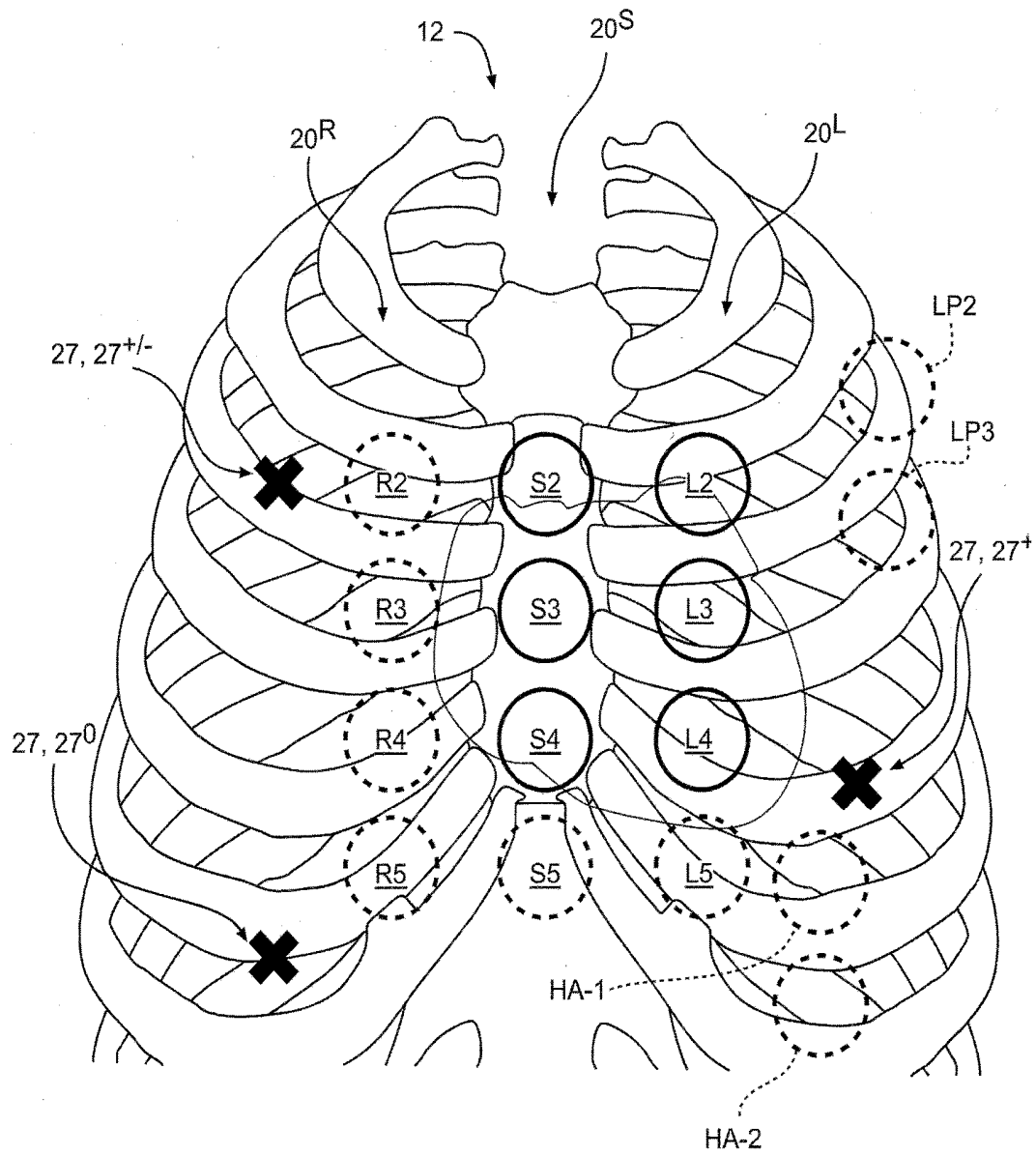
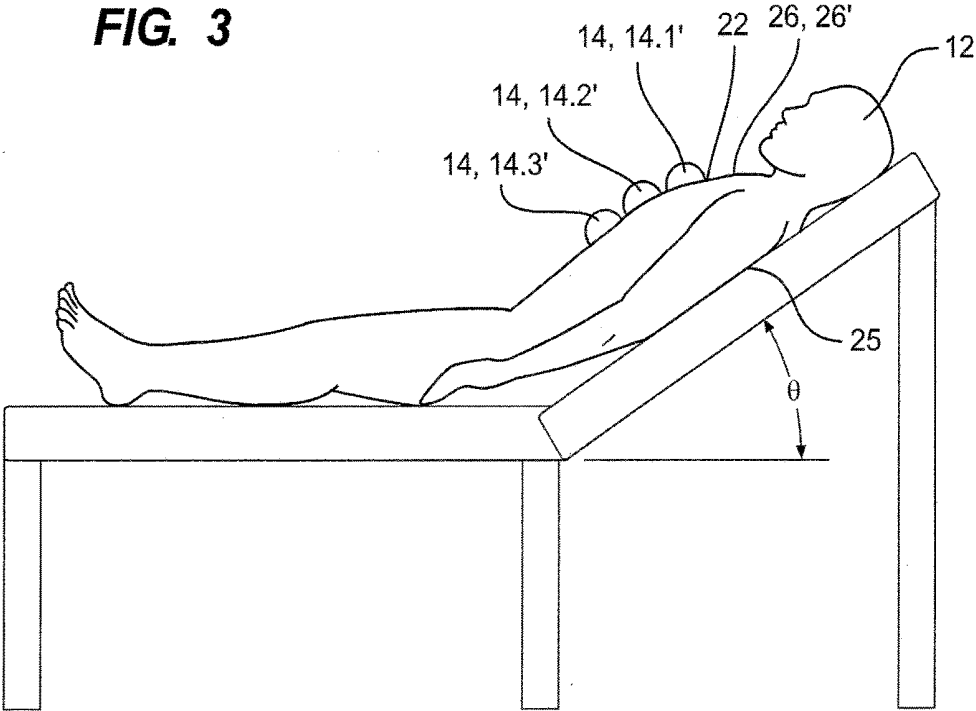

FIG. 2b

FIG. 3



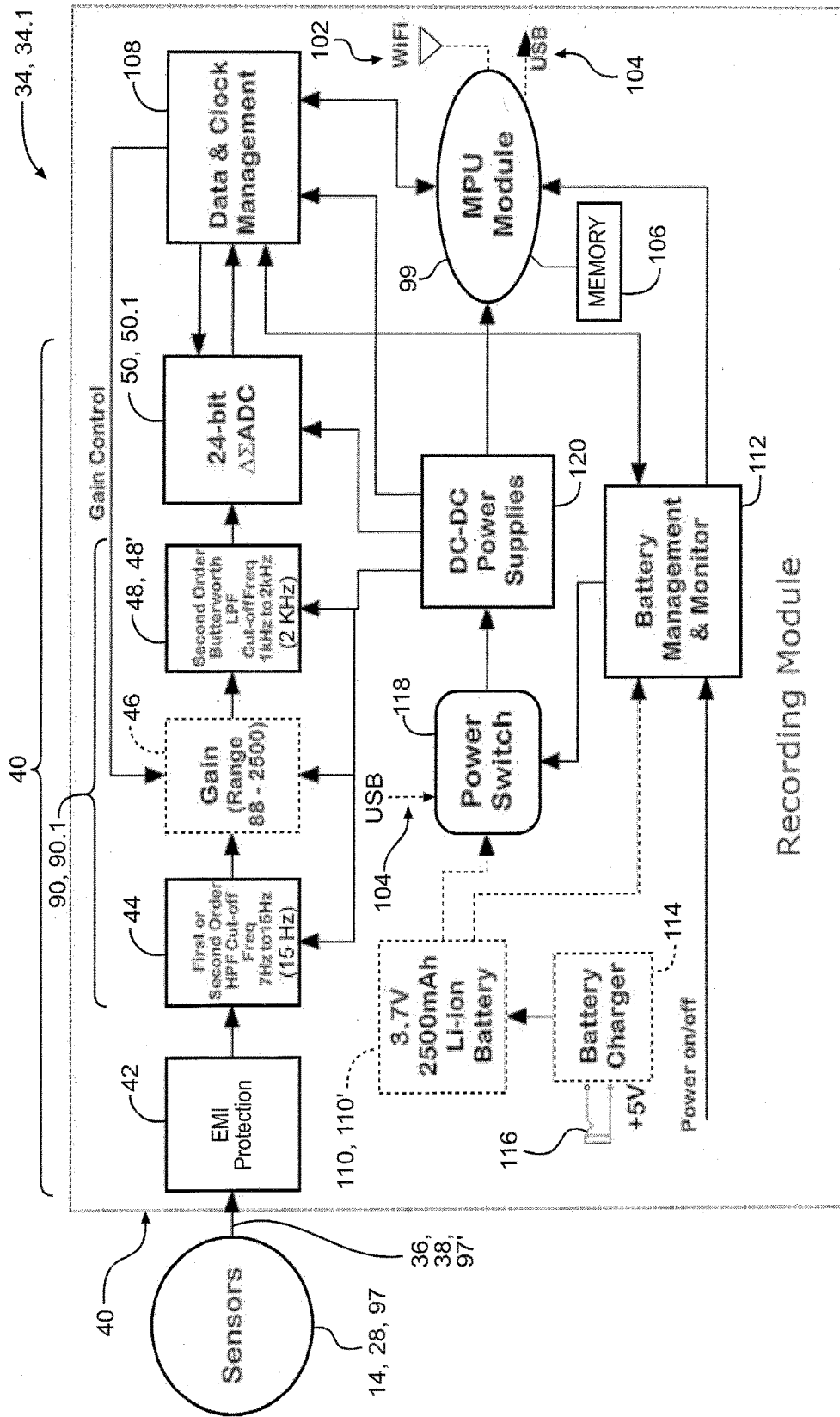

FIG. 4

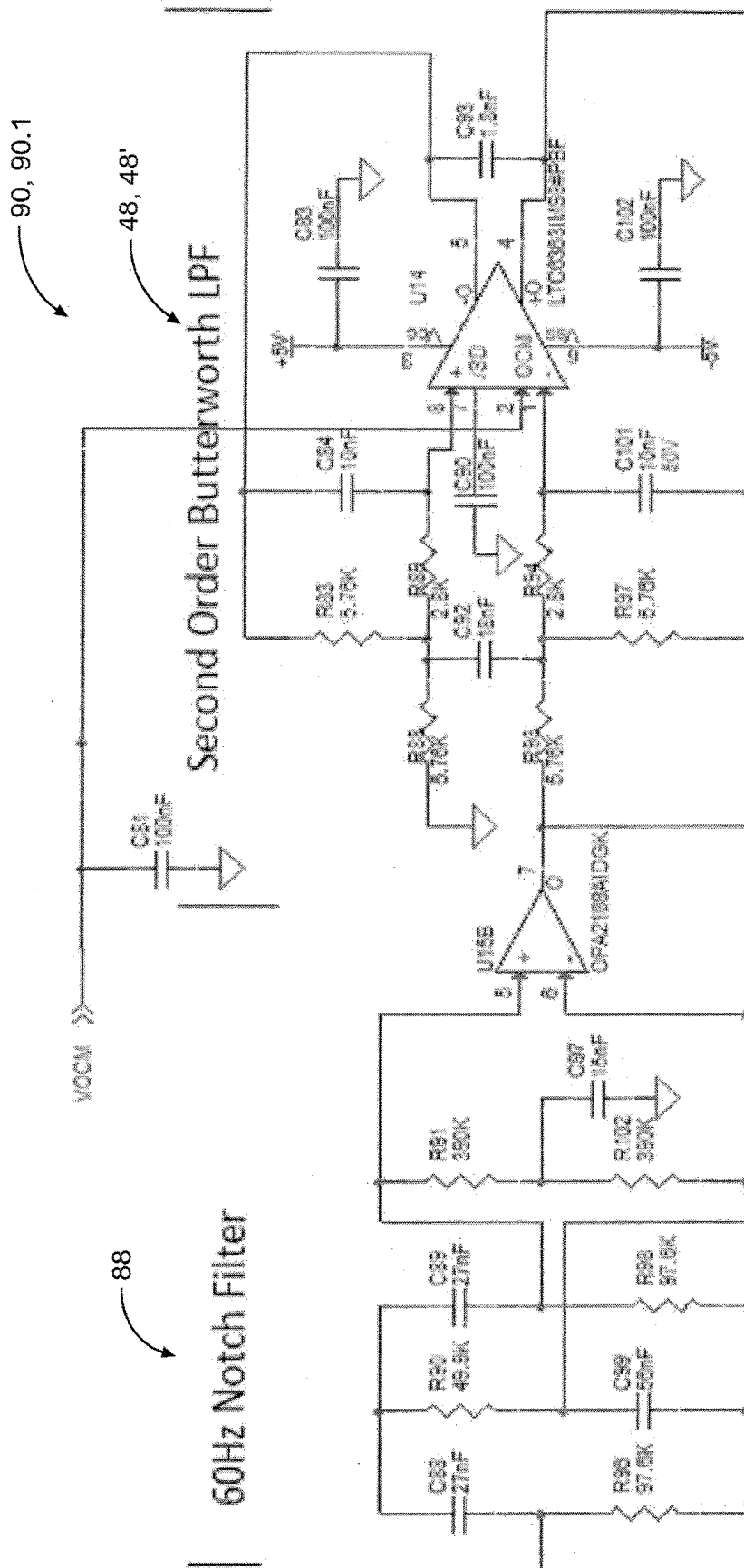

FIG. 5b

FIG 5a

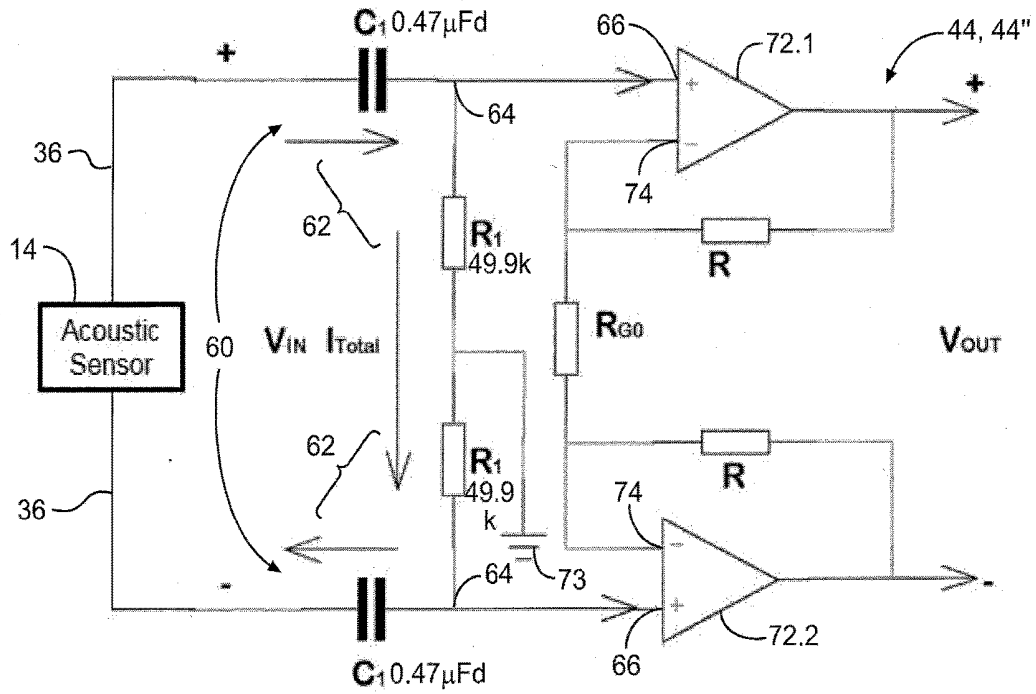

FIG. 6a

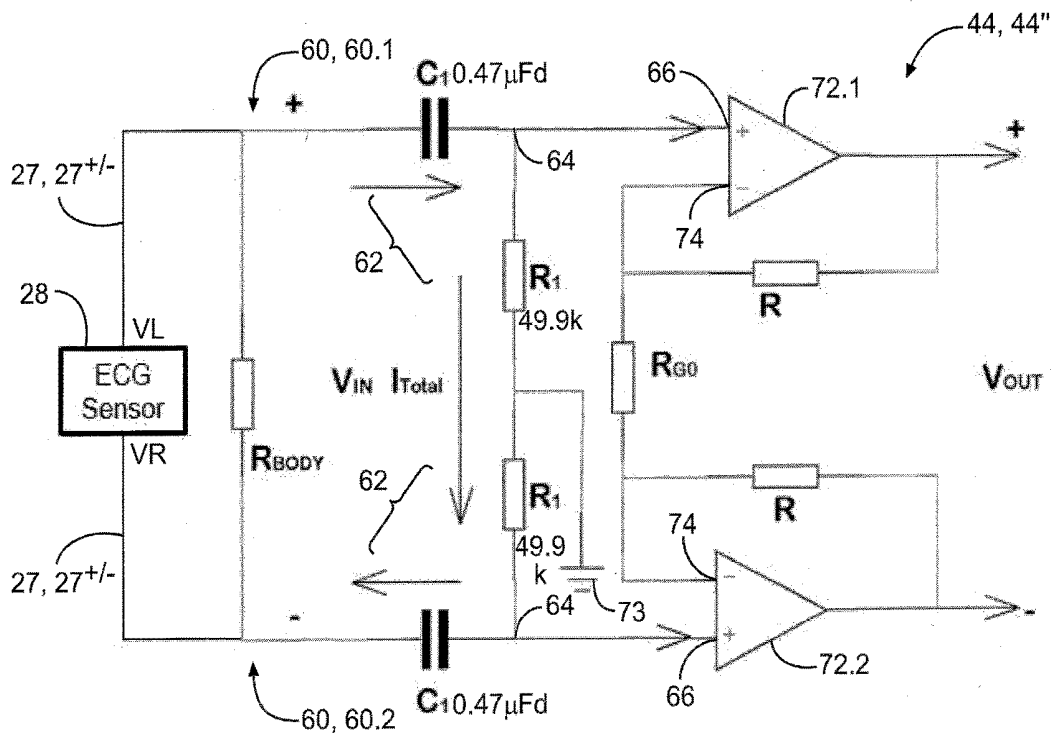

FIG. 6b

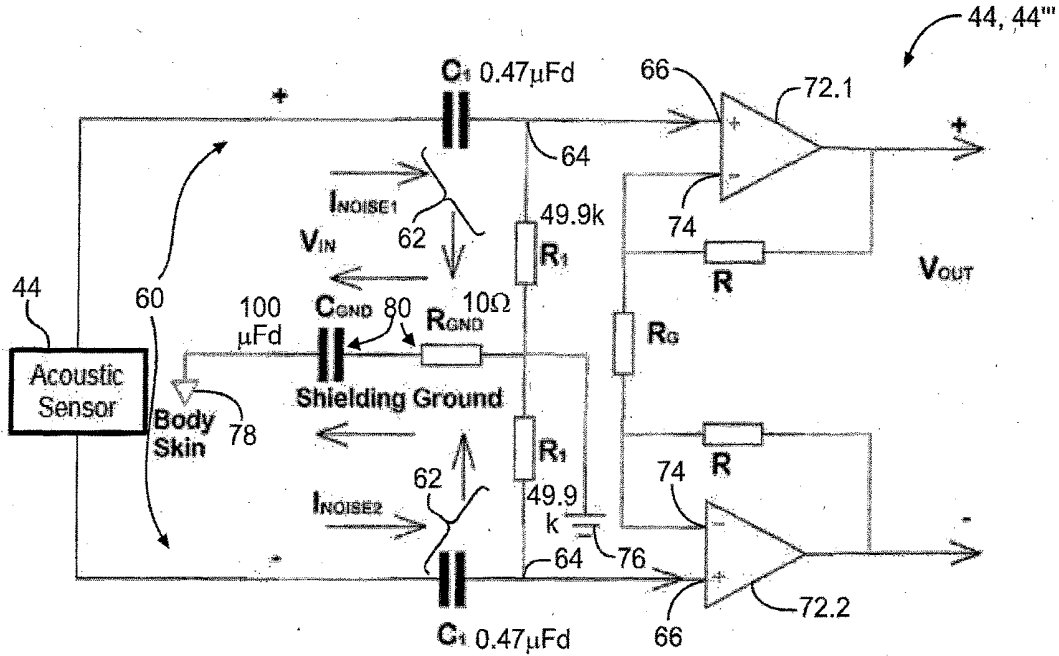

FIG. 7a

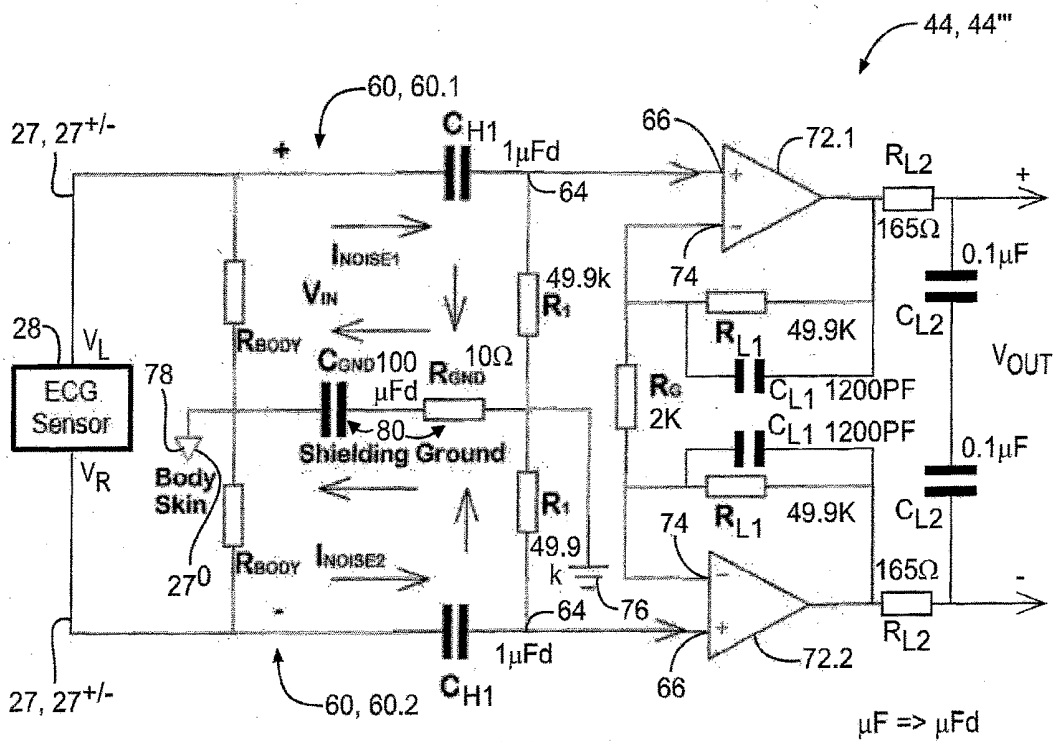

FIG. 7b

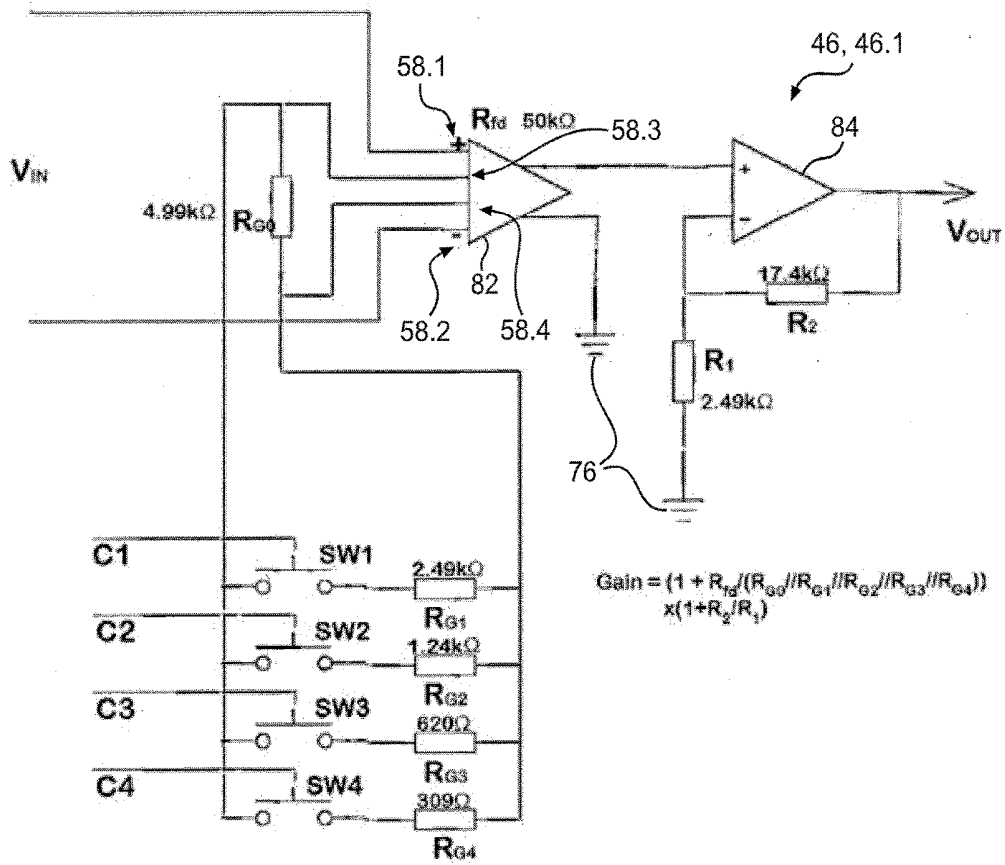

FIG. 8

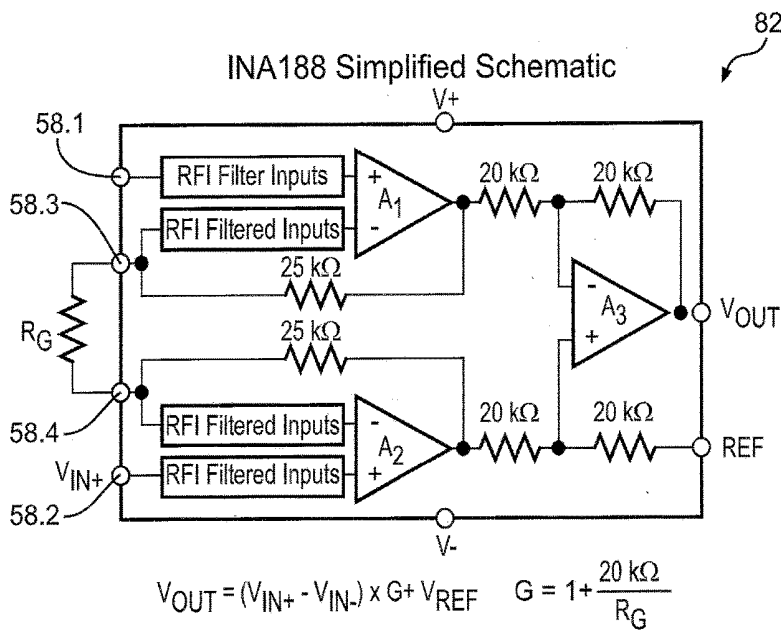

FIG. 9

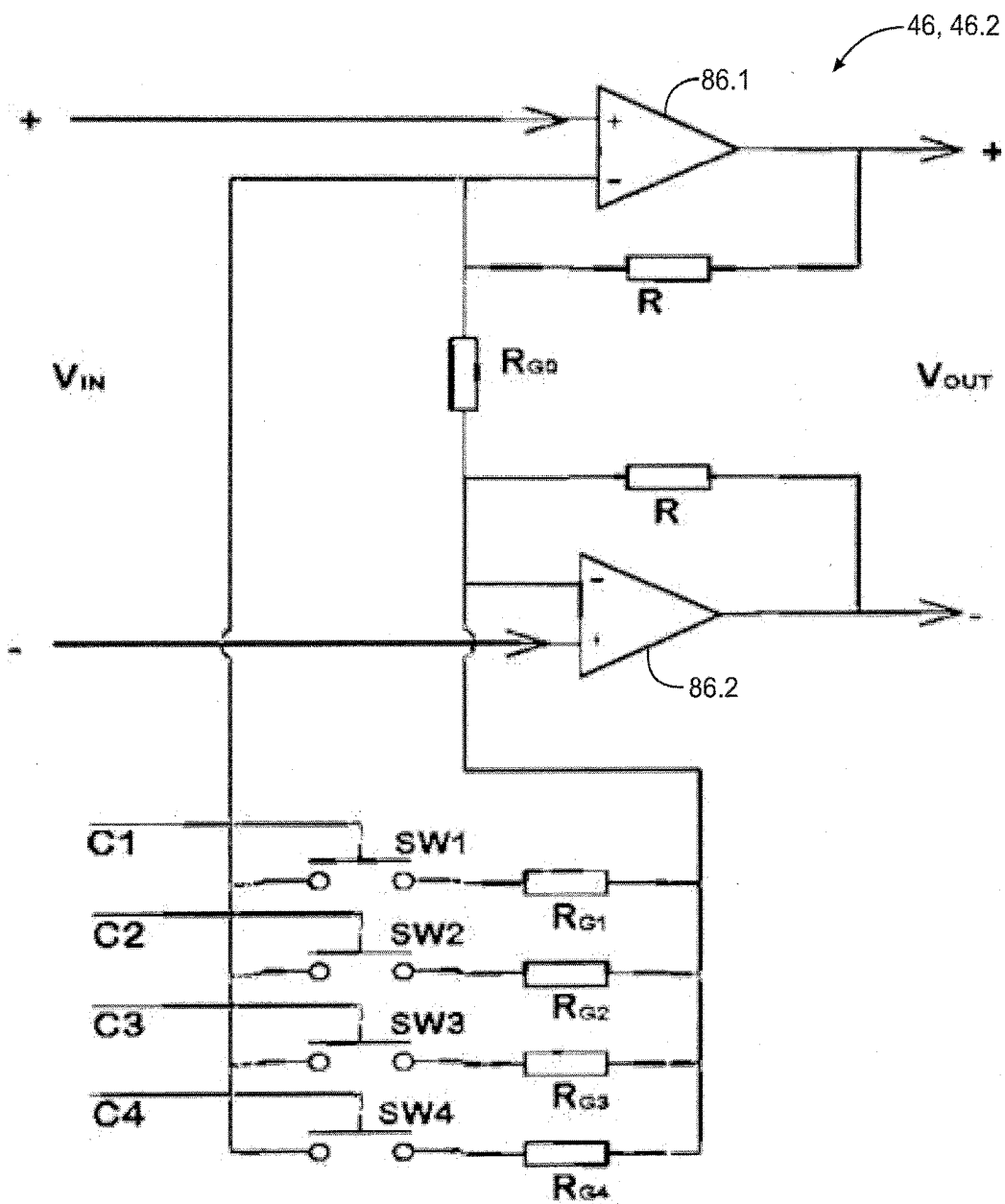
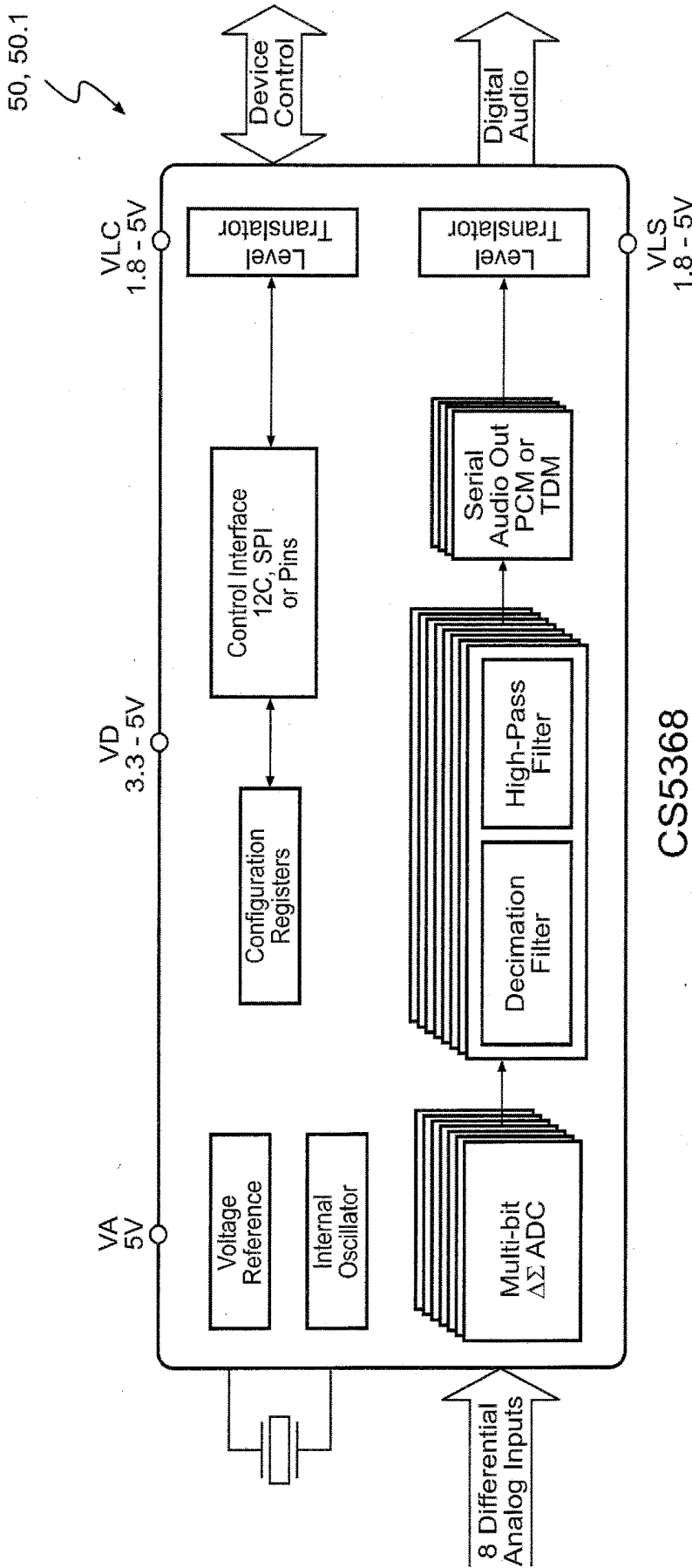

FIG. 10



CS5368

FIG. 11

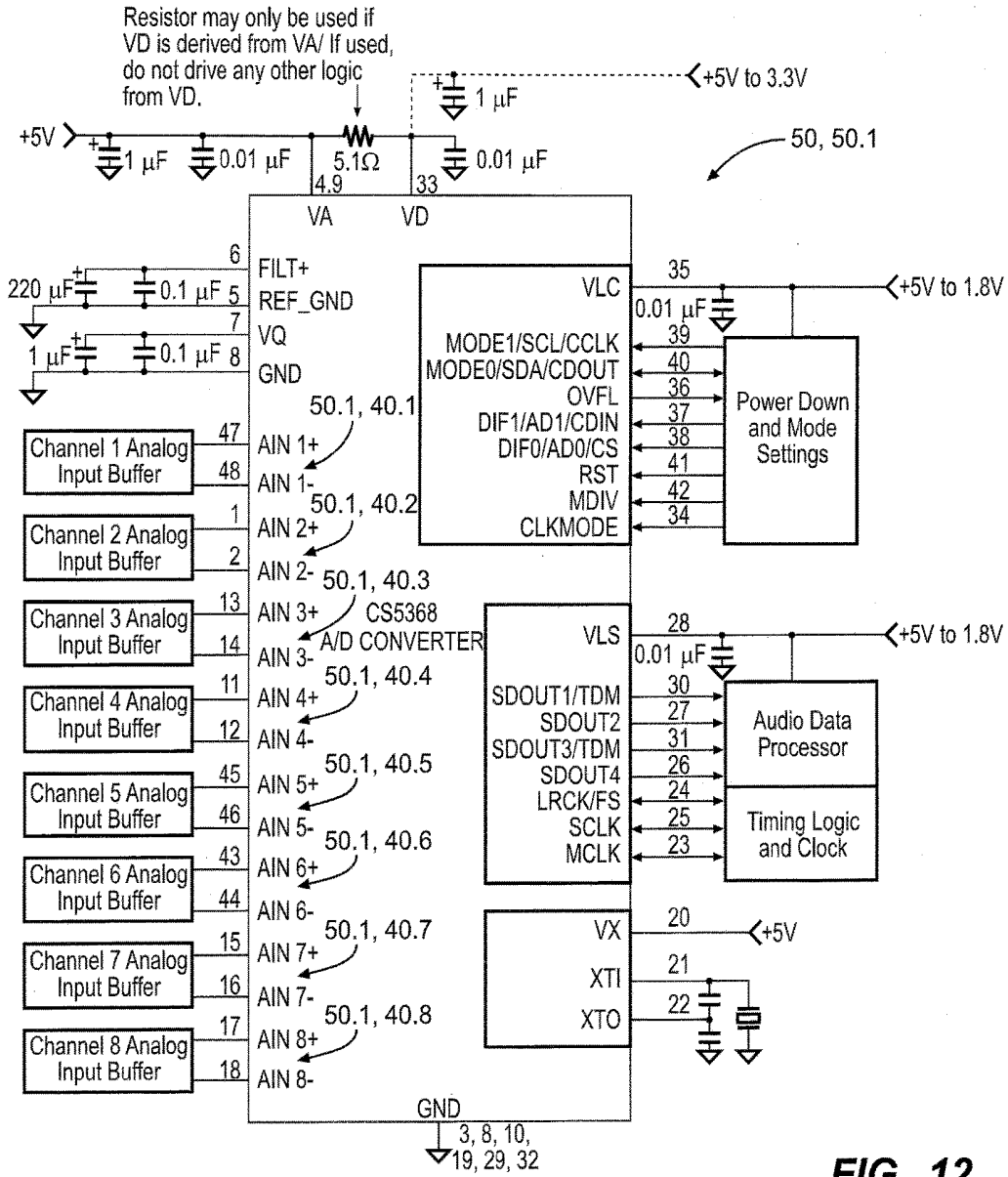
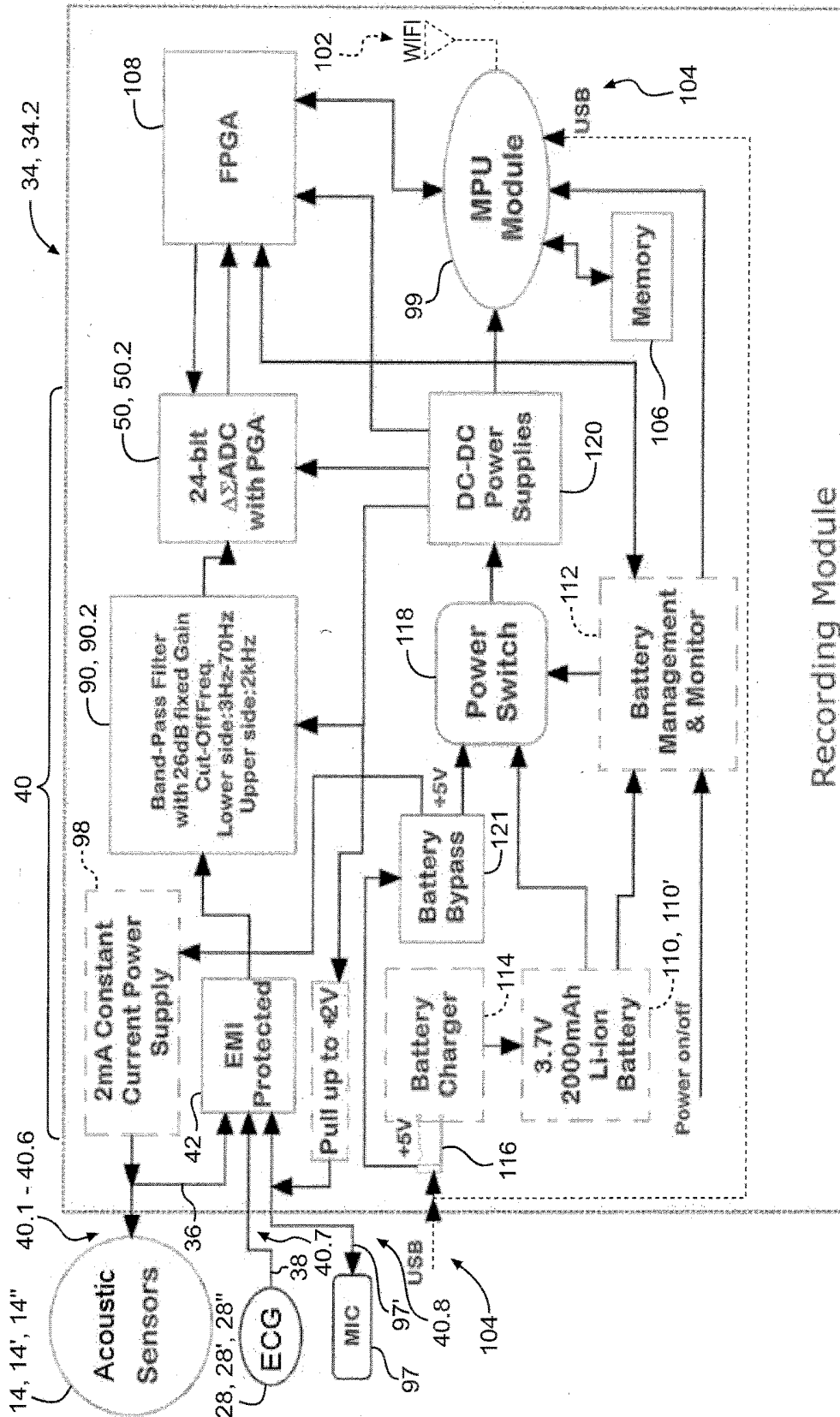

FIG. 12



Recording Module

FIG. 13

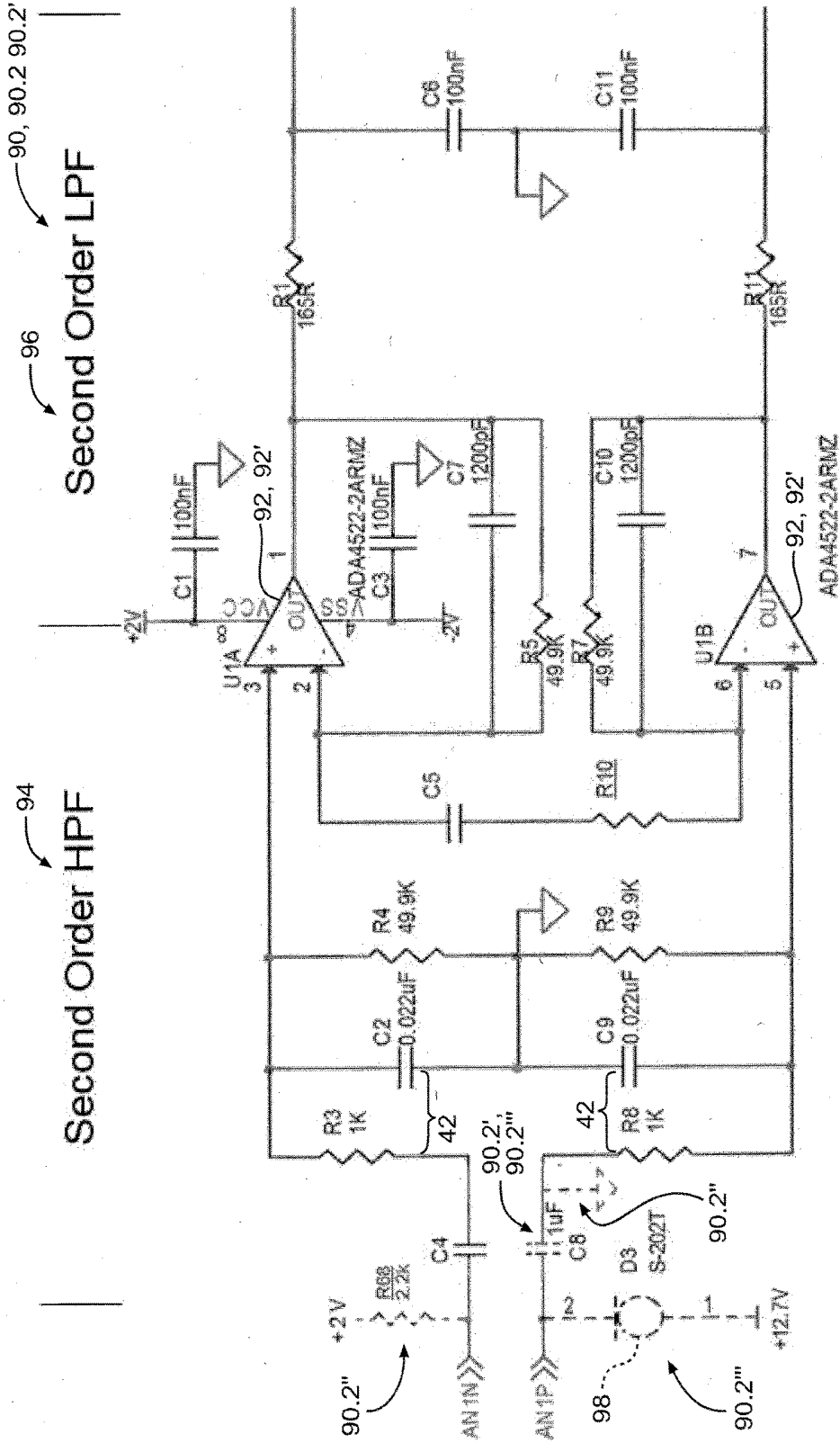

FIG. 14

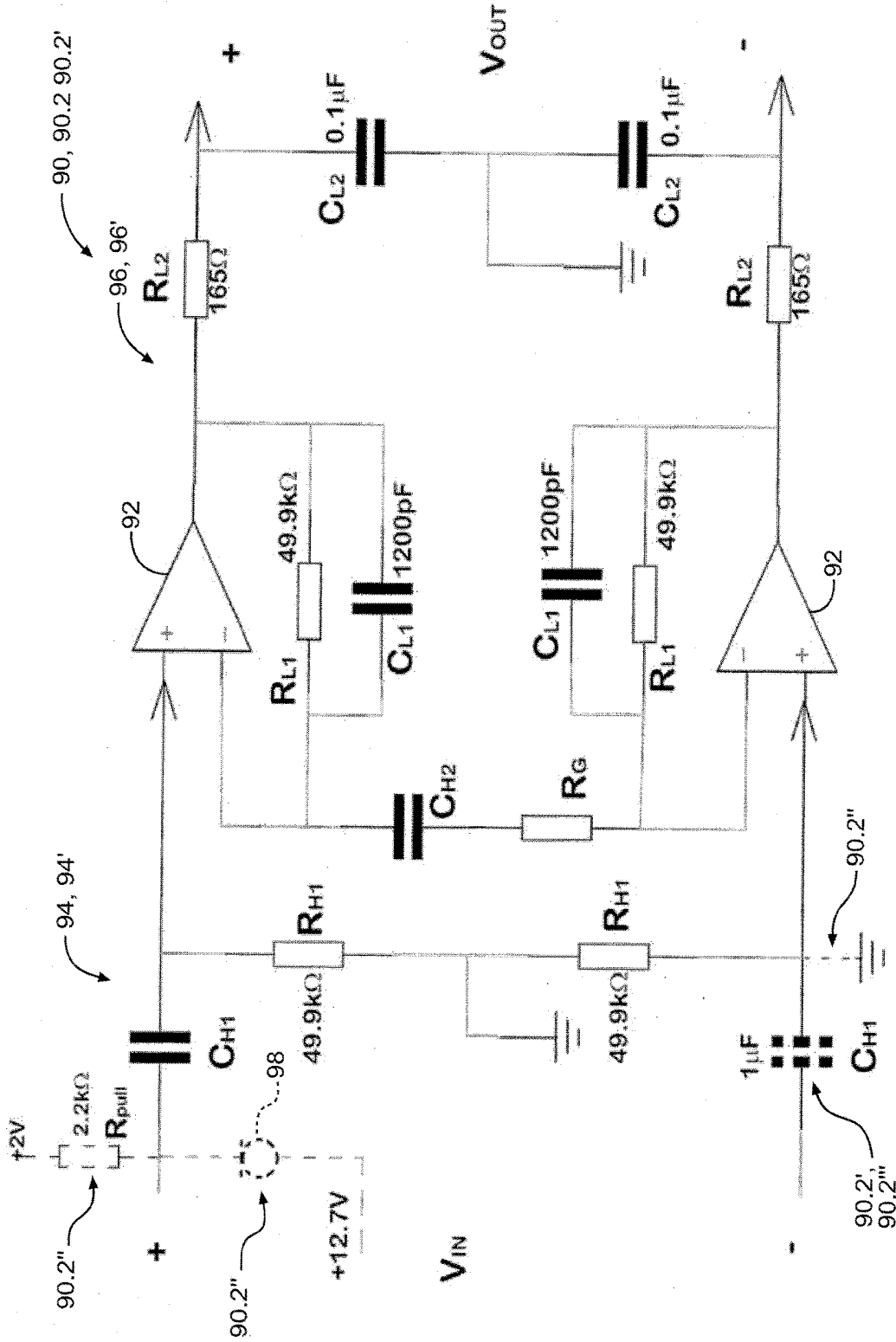

FIG. 15

ADS1299-X Block Diagram

50, 50.2

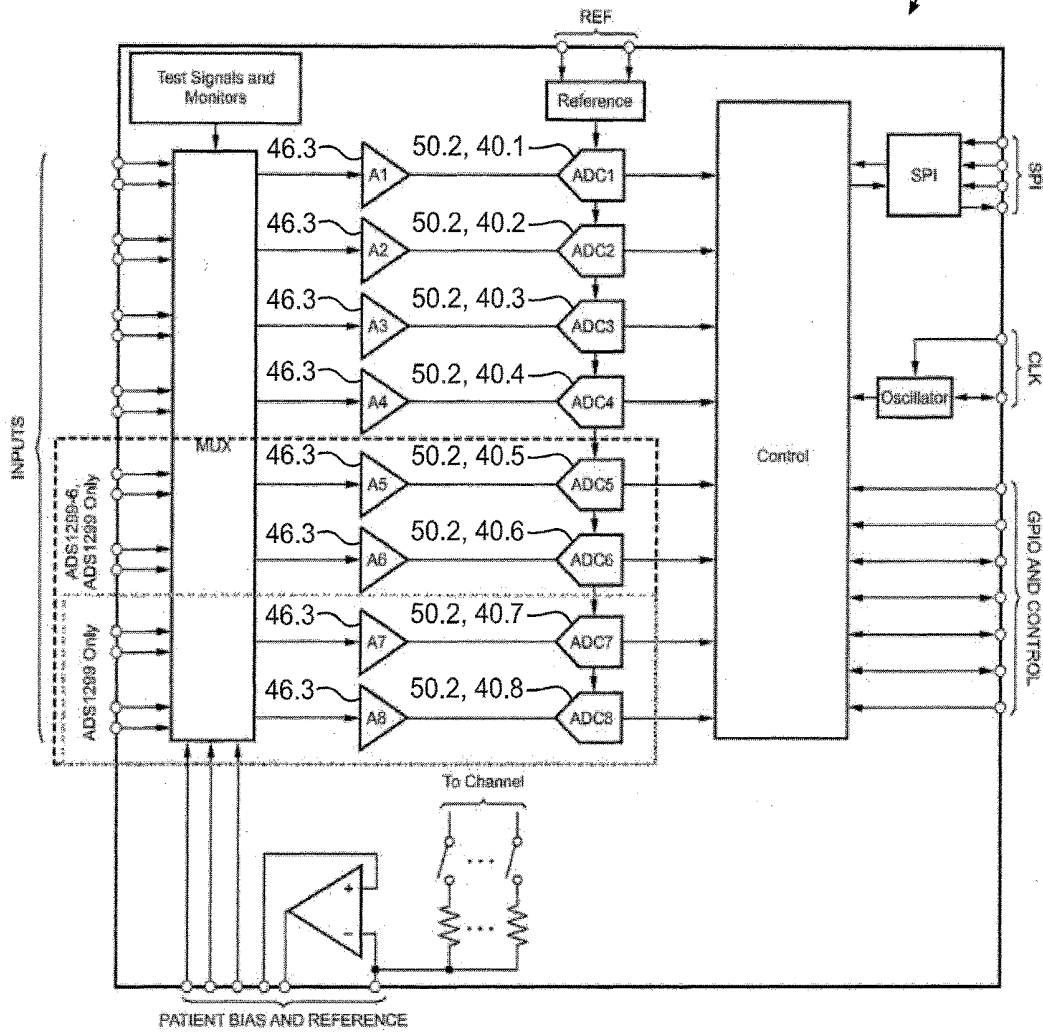

FIG. 16

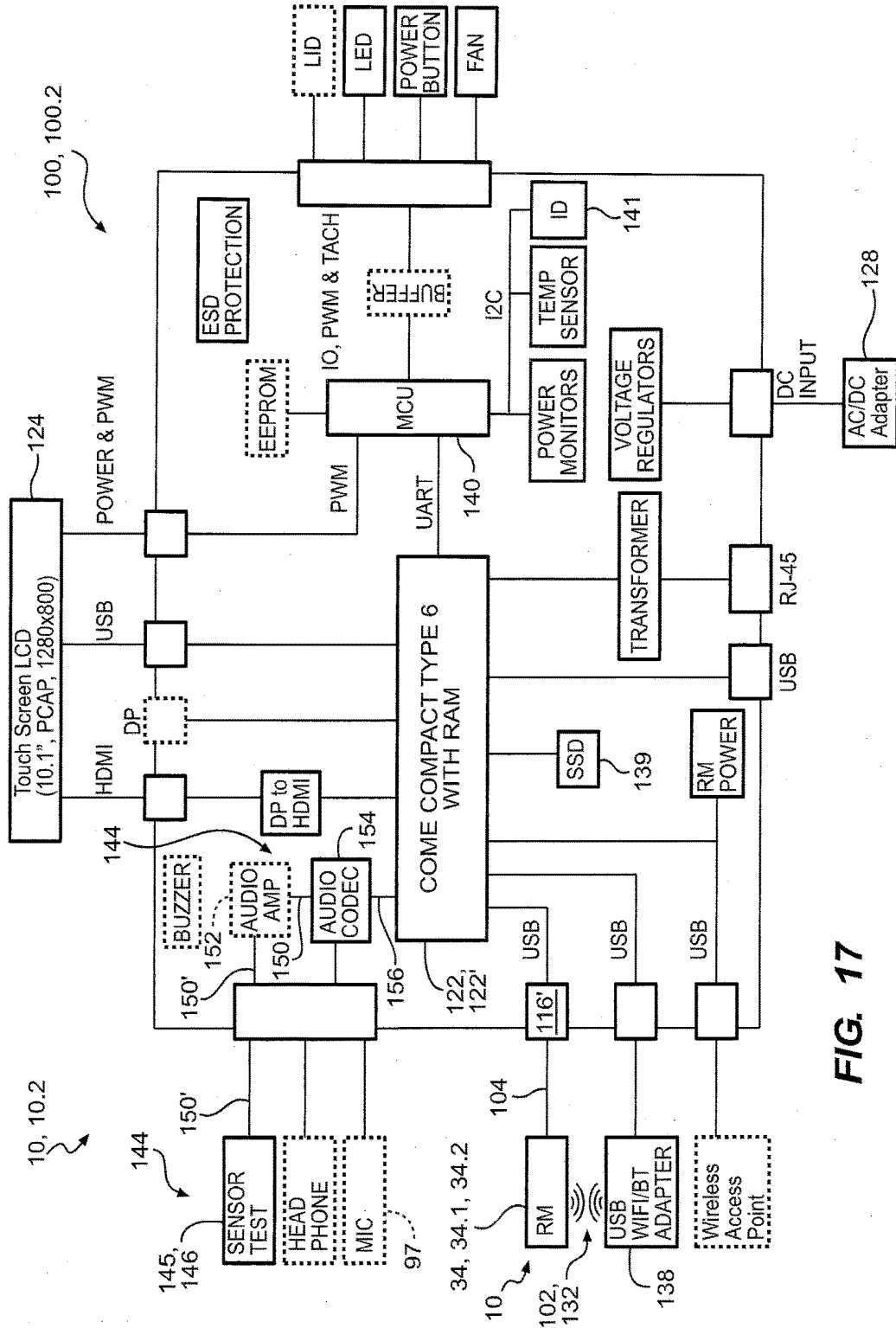

FIG. 17

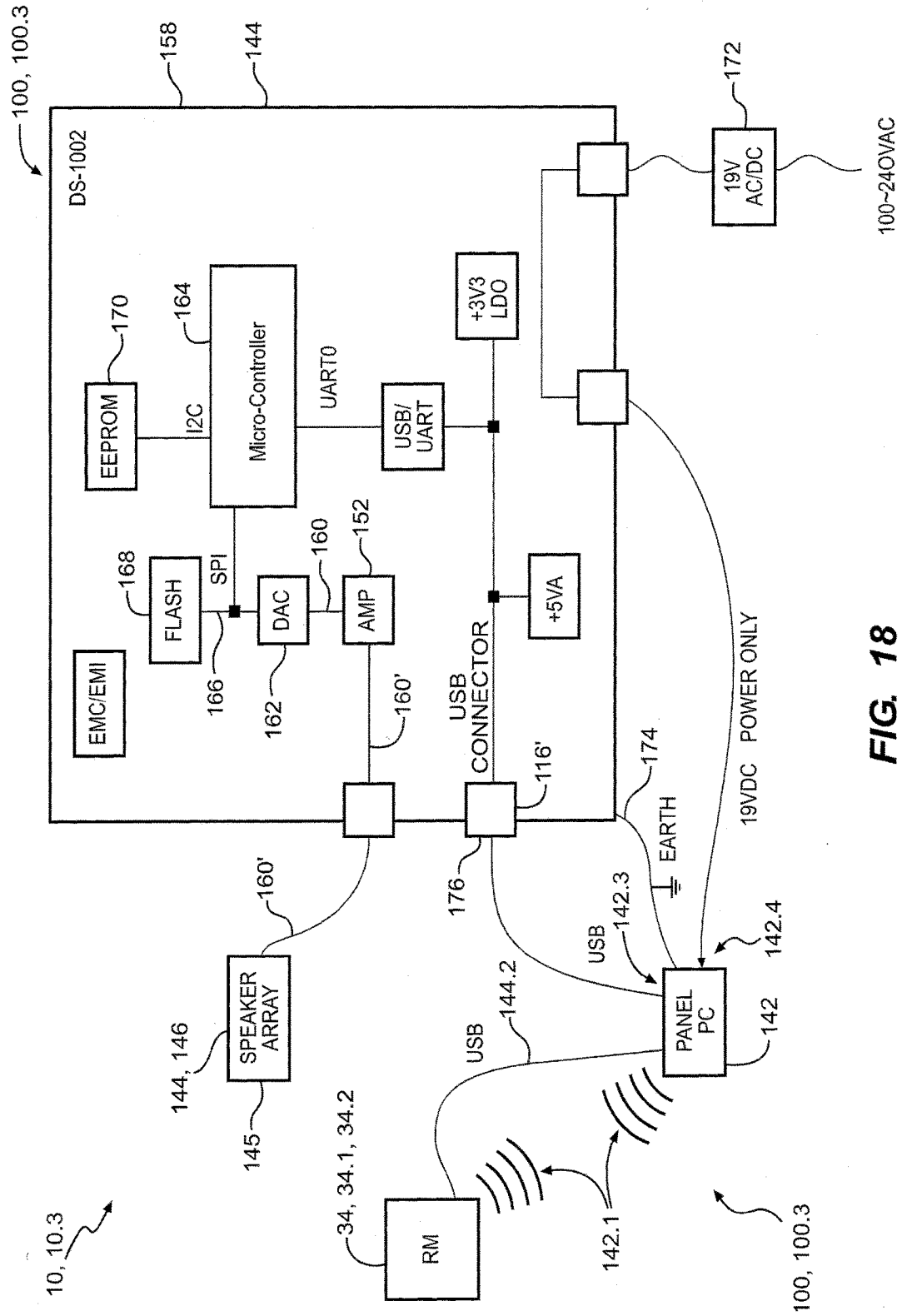

FIG. 18

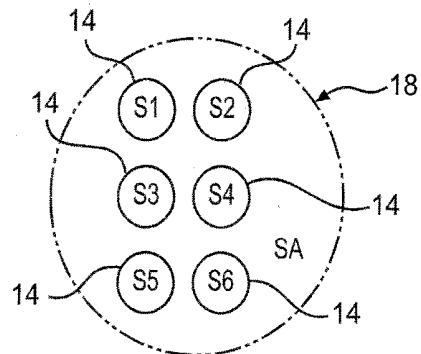

FIG. 19

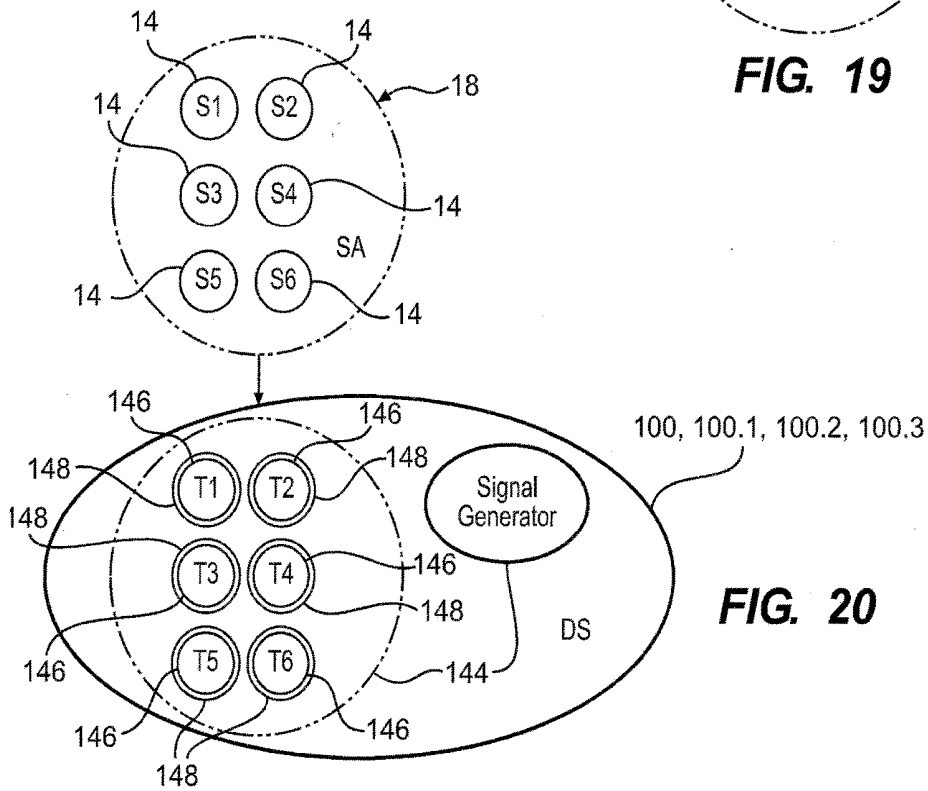

FIG. 20

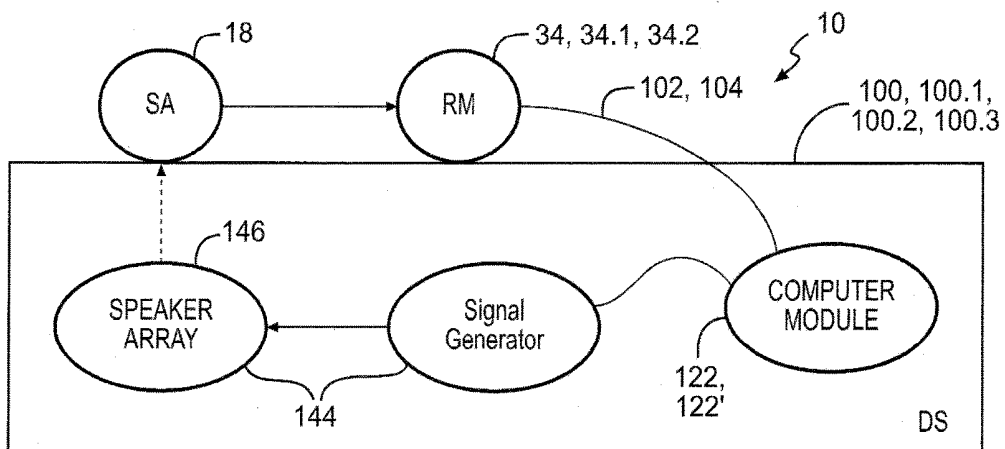

FIG. 21

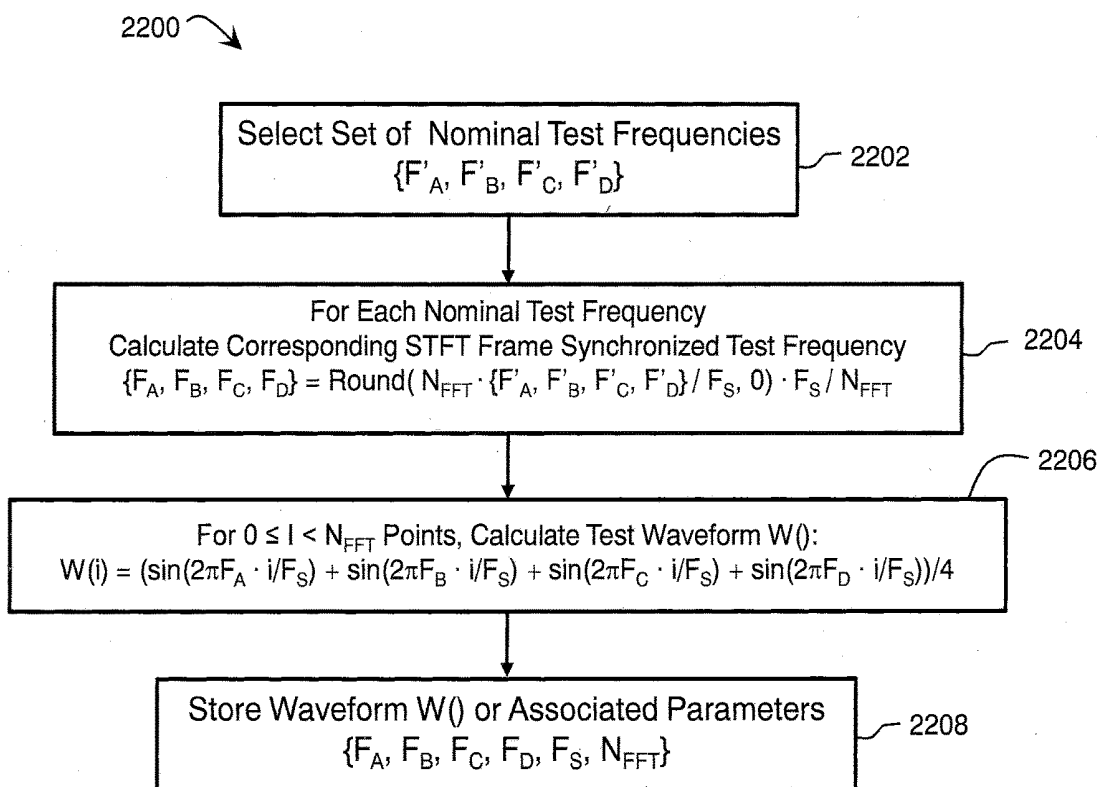

FIG. 22

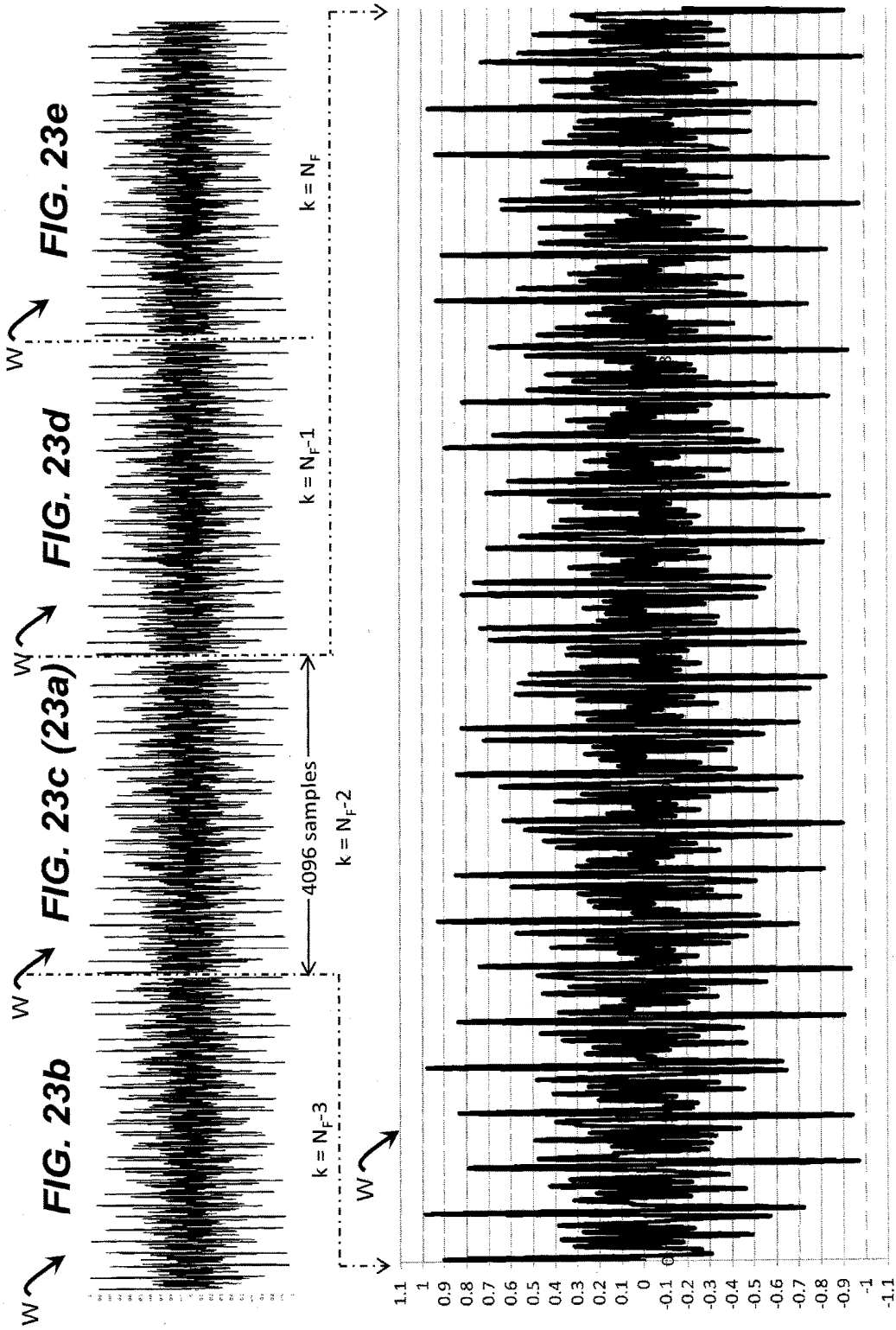

FIG. 23a

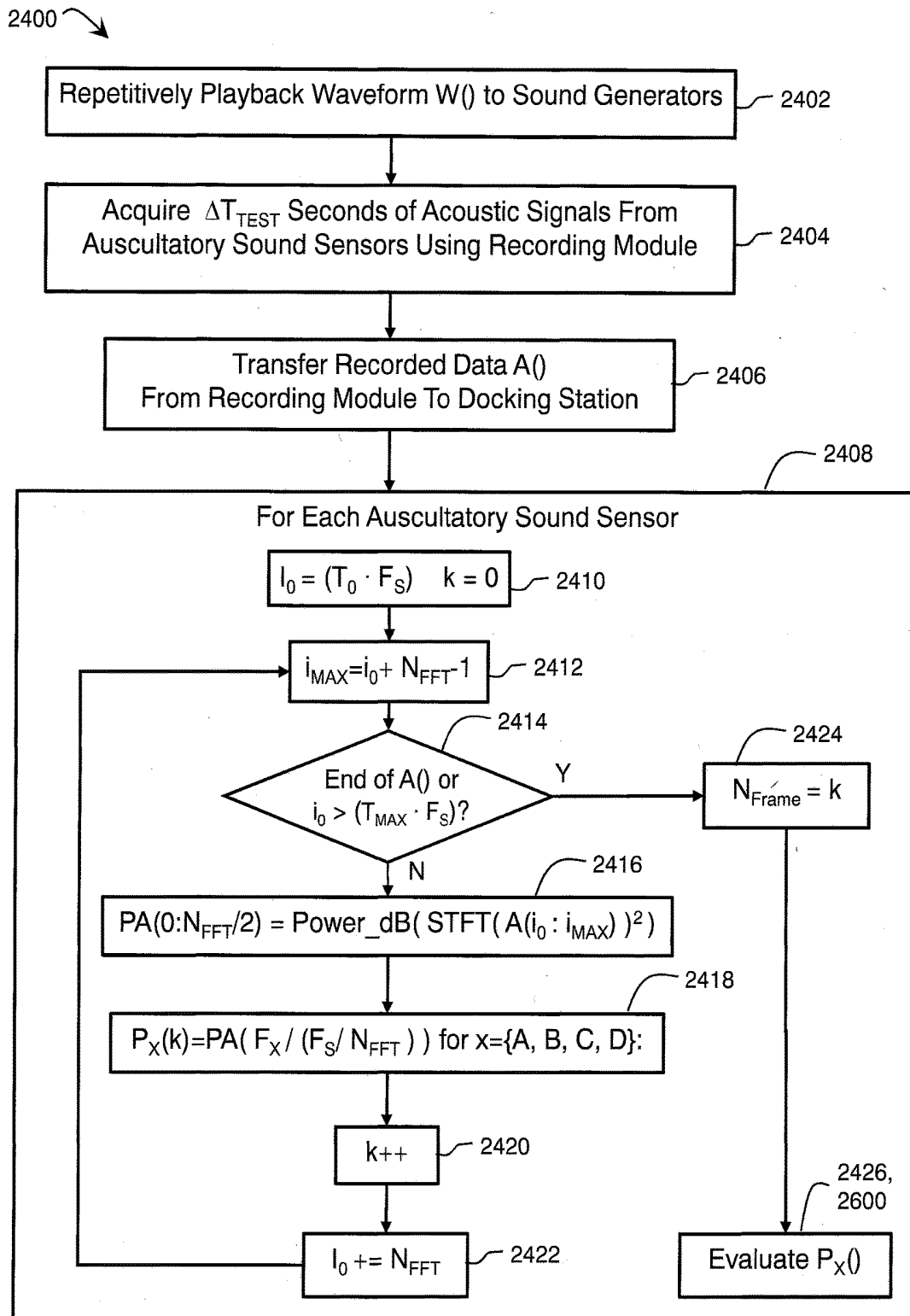

FIG. 24

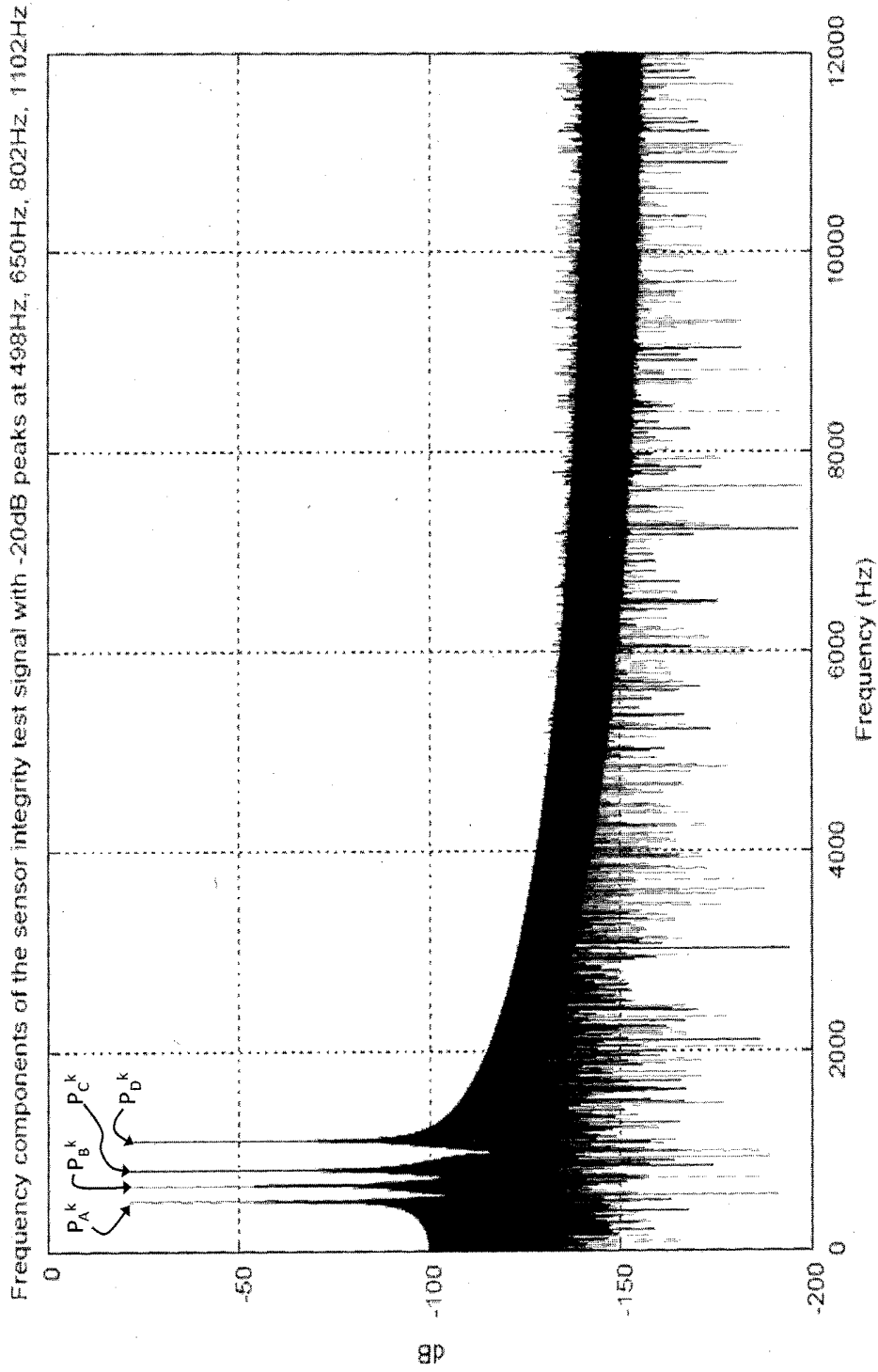

FIG. 25

2600 ↗

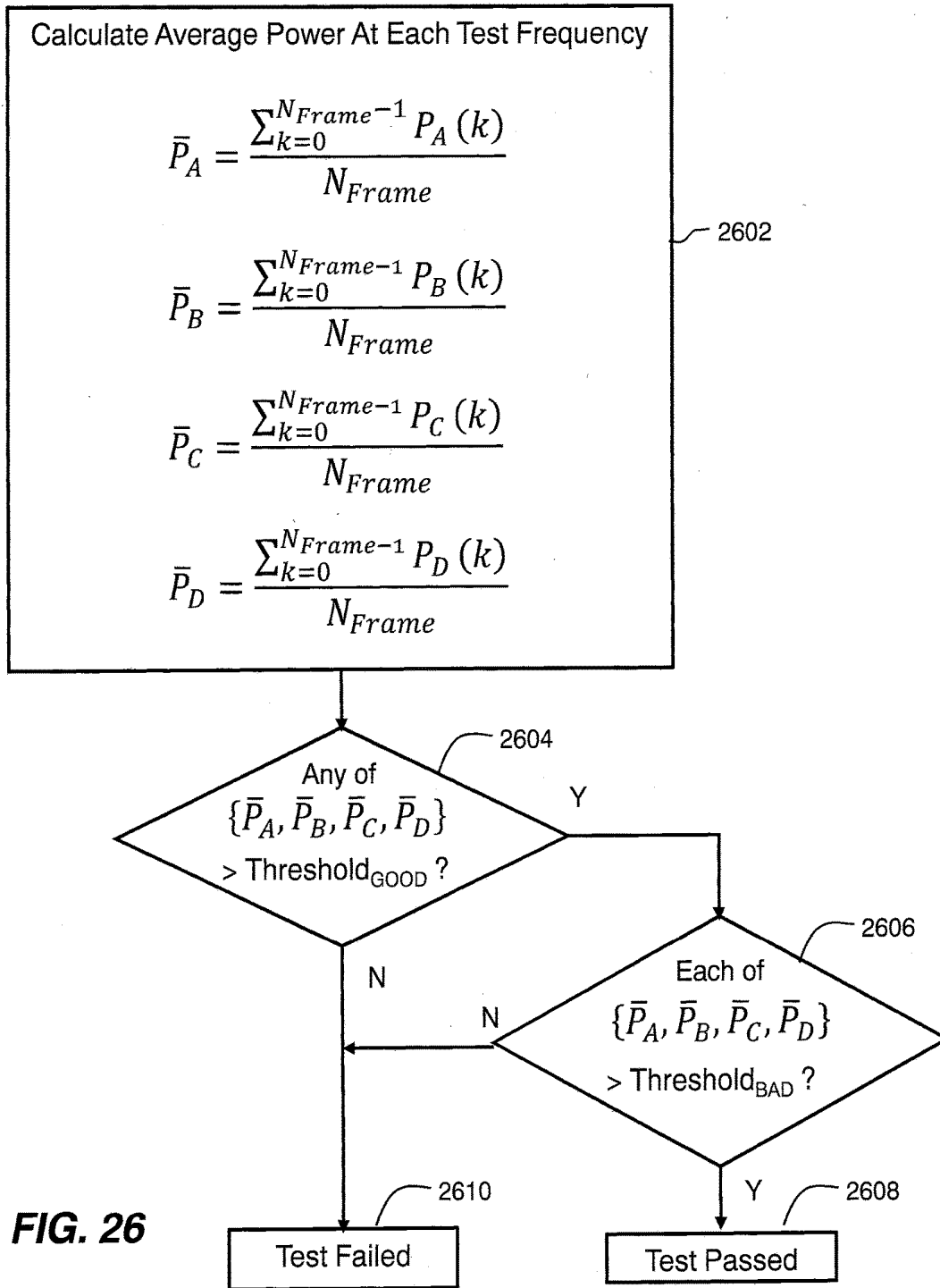
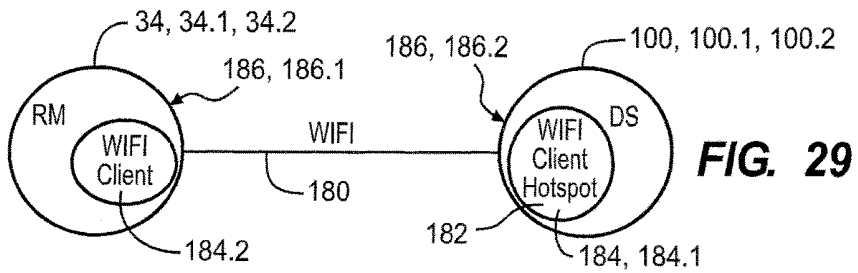
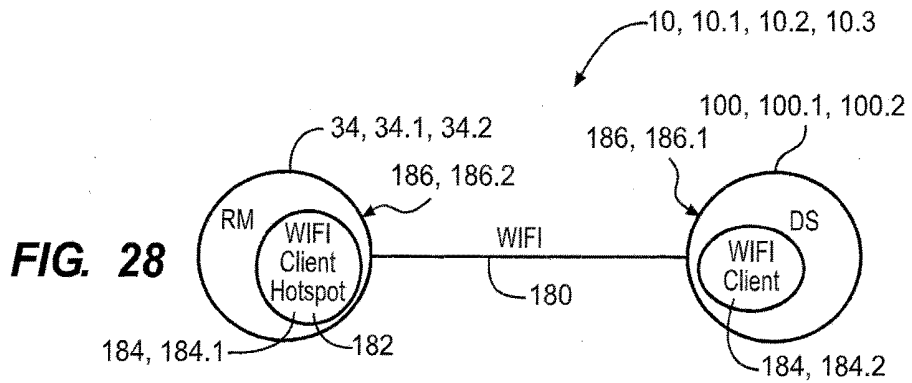
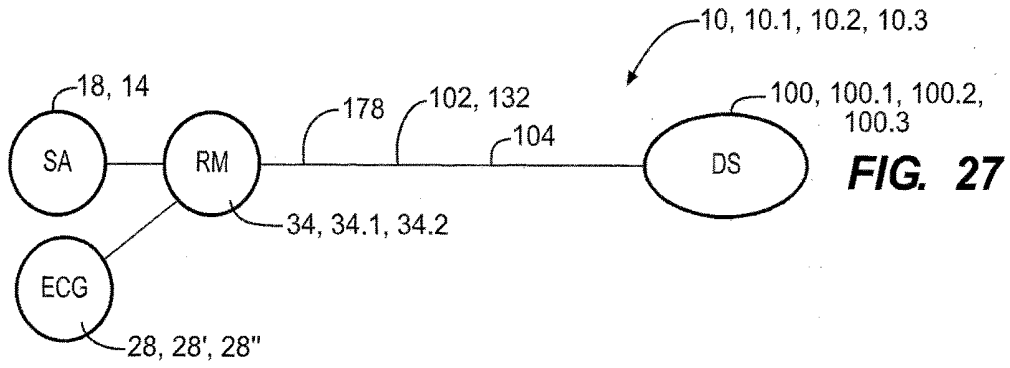
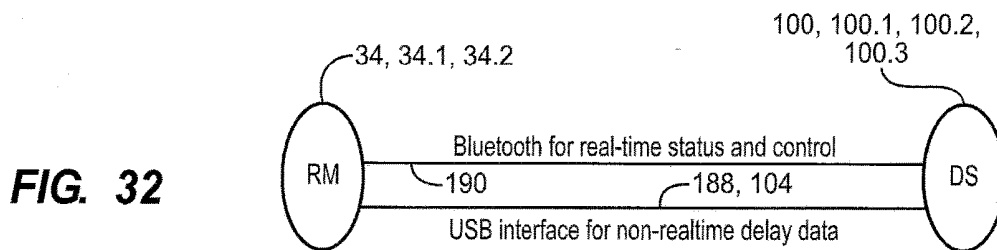
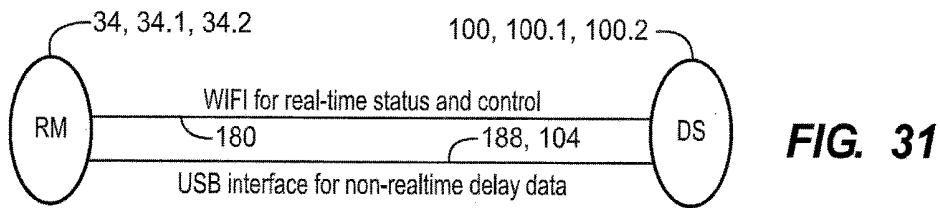
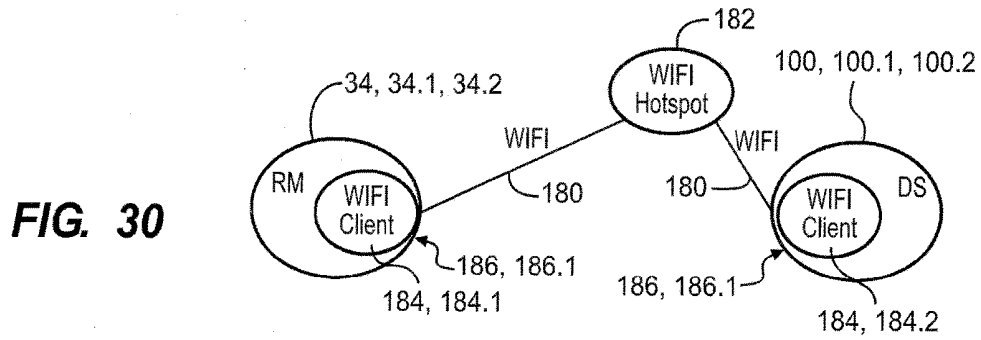

FIG. 26





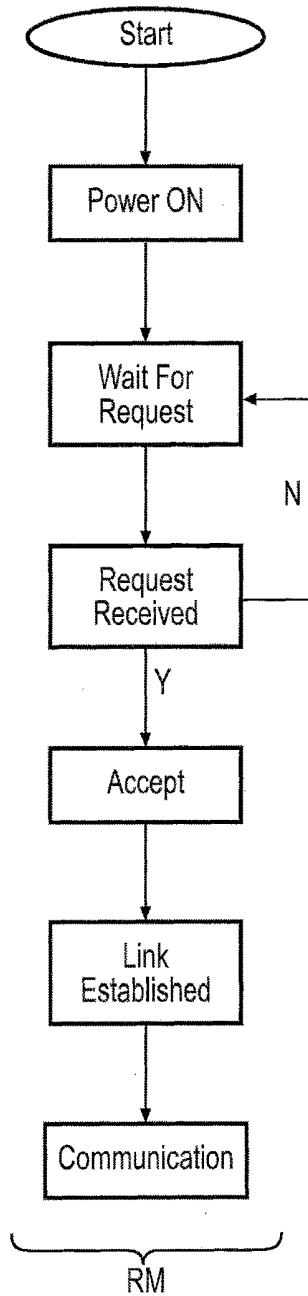

FIG. 33

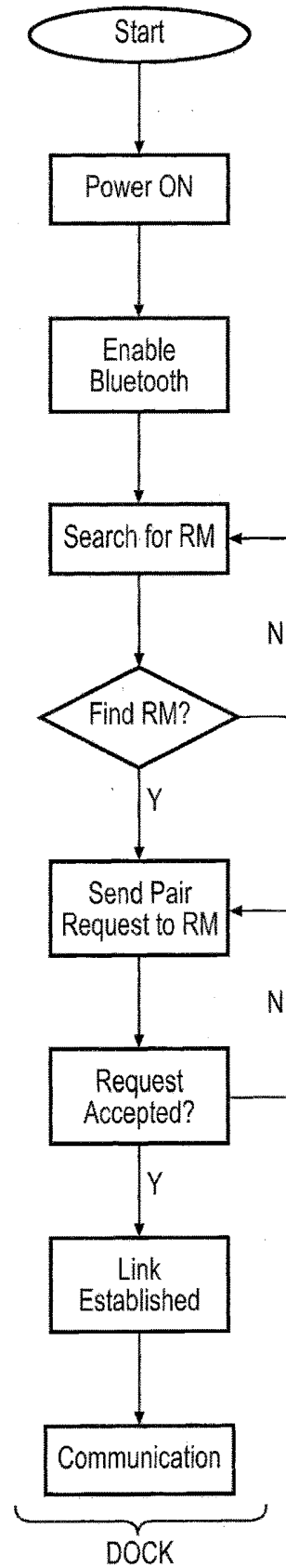

FIG. 34

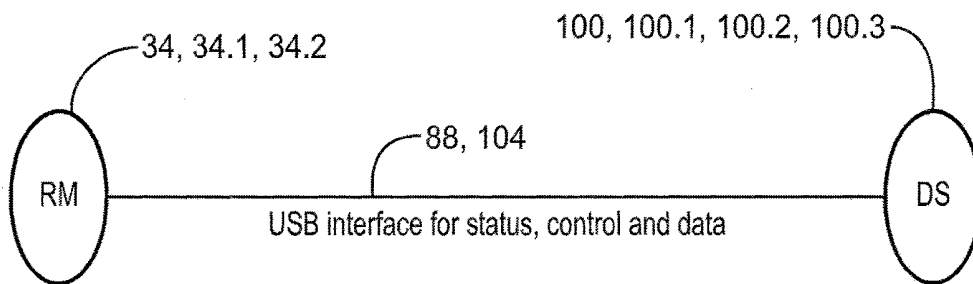

FIG. 35

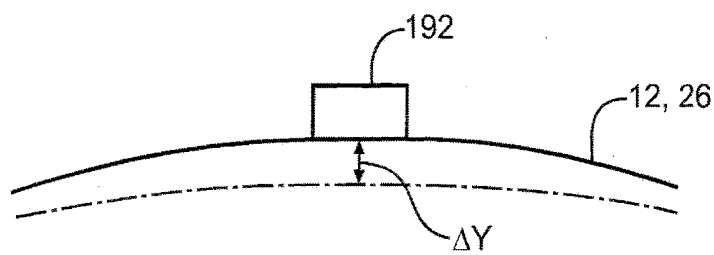

FIG. 36

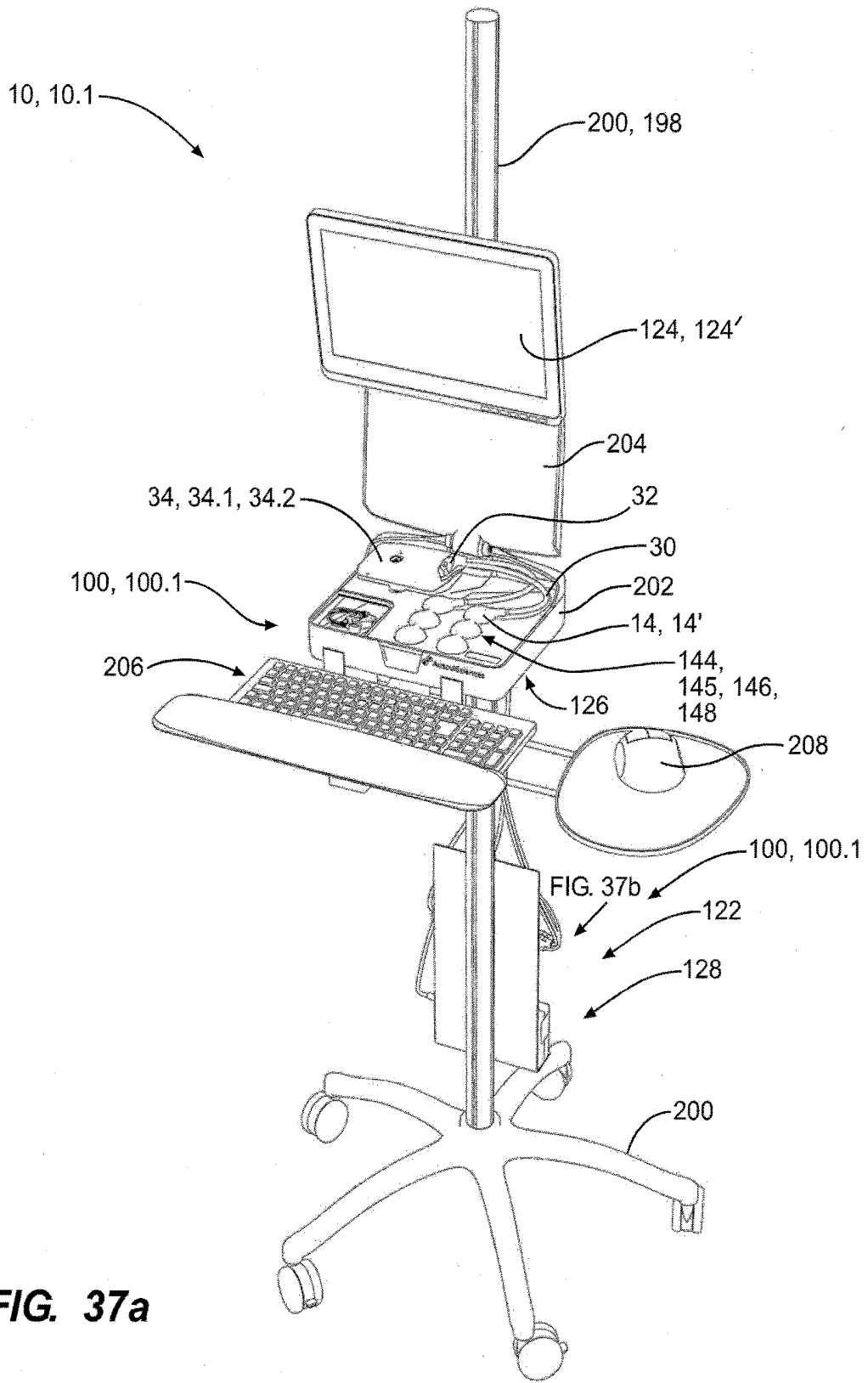
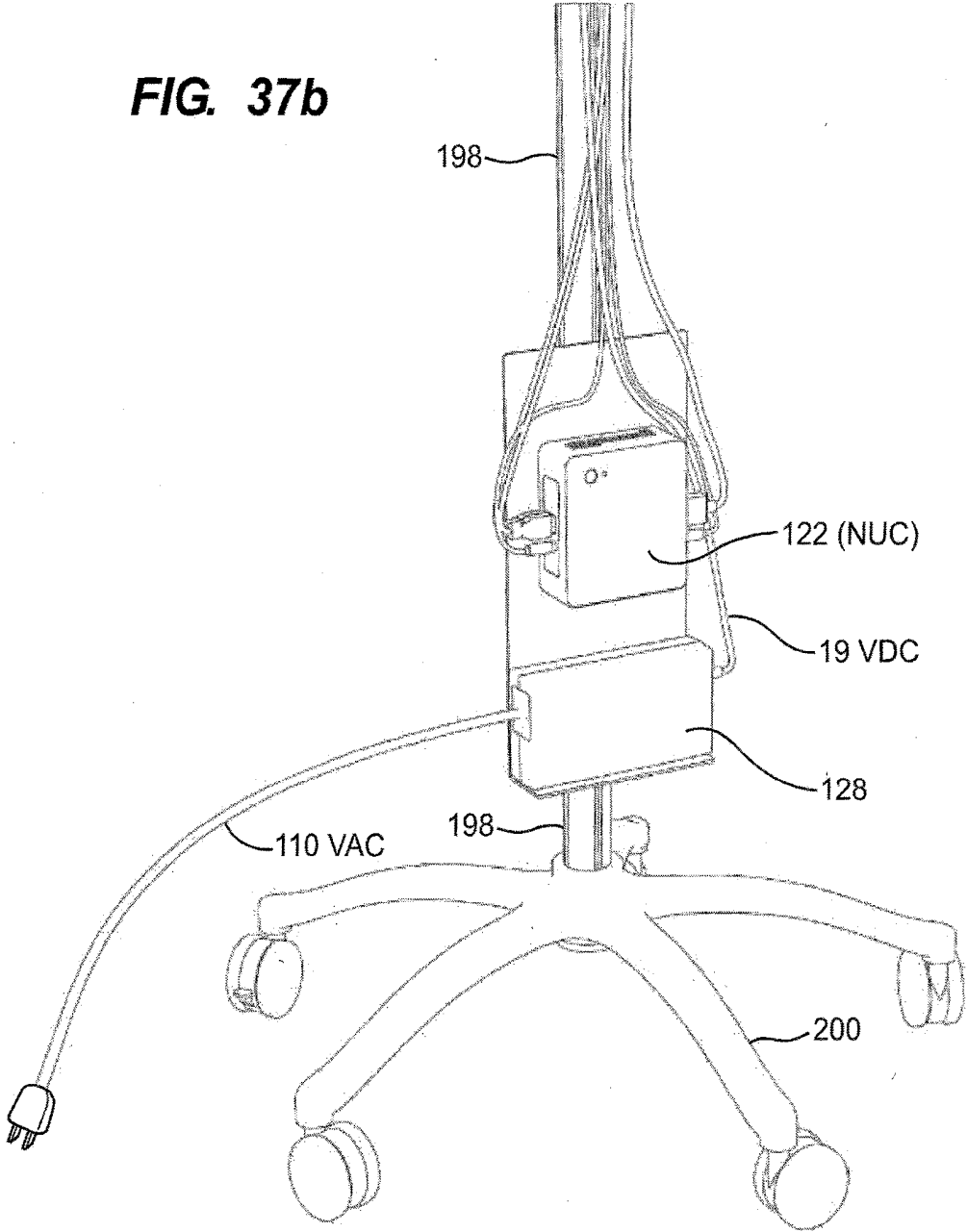

FIG. 37a

FIG. 37b



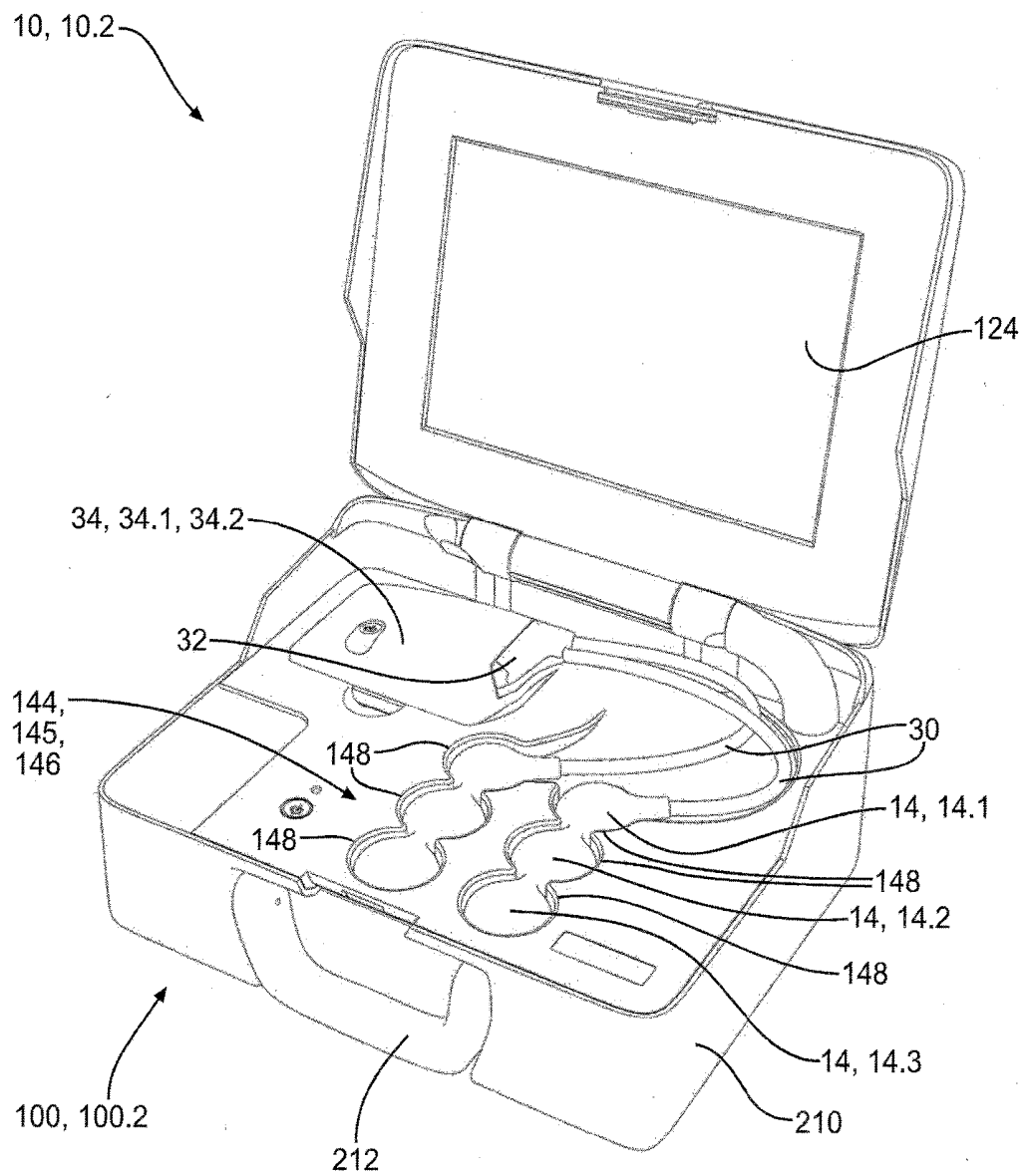

FIG. 38

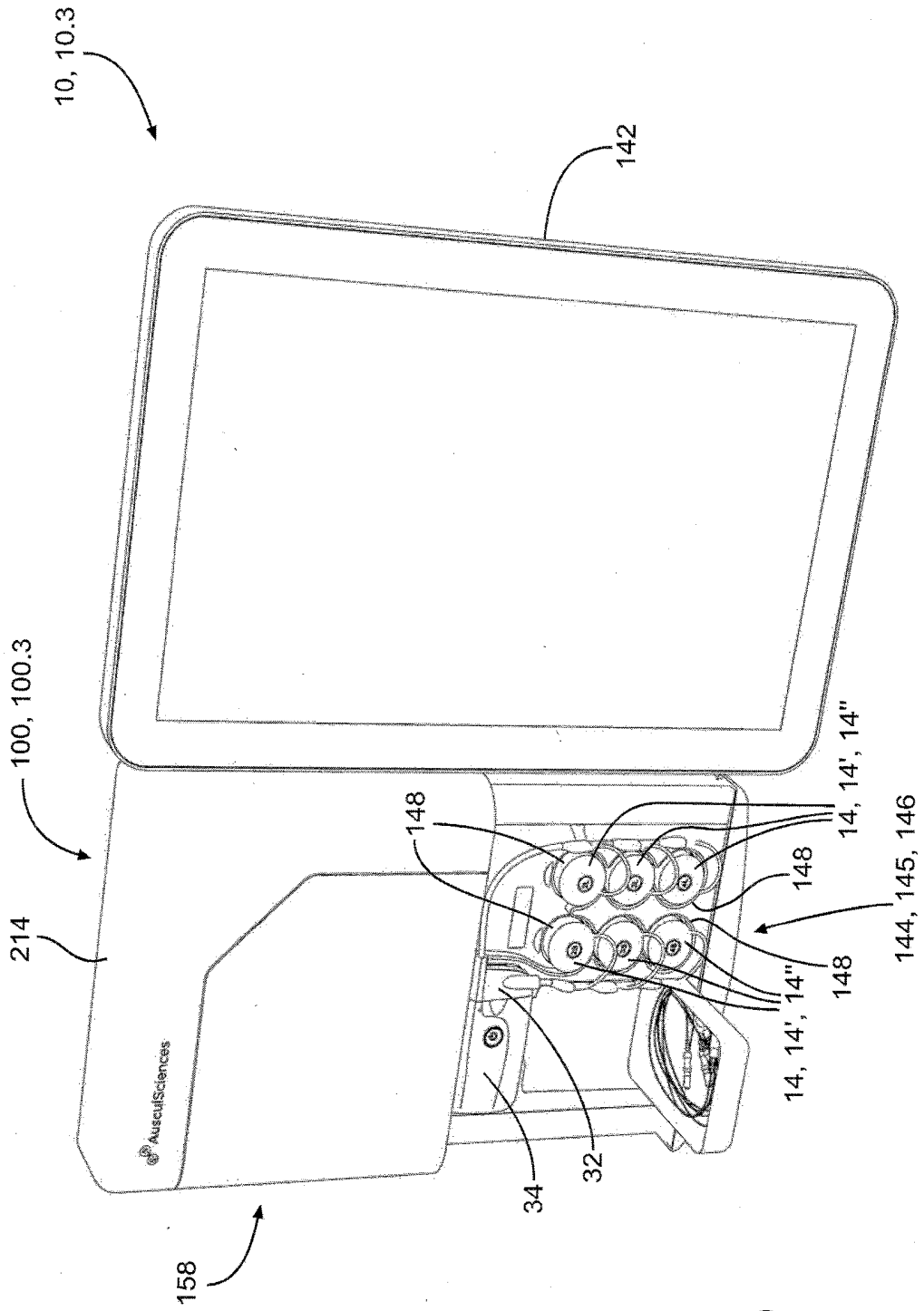

FIG. 39

**CORONARY ARTERY DISEASE DETECTION
SIGNAL PROCESSING SYSTEM AND
METHOD**

CROSS-REFERENCE TO RELATED
APPLICATIONS

[0001] The instant application claims the benefit of the U.S. Provisional Application Ser. No. 62/575,364 filed on 20 Oct. 2017, which is incorporated herein by reference in its entirety.

BRIEF DESCRIPTION OF THE DRAWINGS

[0002] In the accompanying drawings:

[0003] FIG. 1 illustrates a block diagram of a first aspect of a coronary artery disease detection system, incorporating a first aspect of an associated docking system;

[0004] FIG. 2a illustrates a plurality of auscultatory sound-or-vibration sensors attached to the thorax of a test subject and operatively coupled to an associated recording module of the coronary-artery-disease detection system illustrated in FIG. 1, for gathering associated auscultatory sound signals used to diagnose cardiovascular health;

[0005] FIG. 2b illustrates a plurality of prospective locations of auscultatory sound-or-vibration sensors and ECG sensors on the thorax of the test subject illustrated in FIG. 2a;

[0006] FIG. 3 illustrates a test subject reclined on a surface, with their torso inclined while capturing auscultatory sound signals from a plurality of auscultatory sound-or-vibration sensors attached to the thorax of the test subject;

[0007] FIG. 4 illustrates a block diagram of a first aspect of a recording module of the coronary-artery-disease detection system illustrated in FIG. 1;

[0008] FIG. 5a illustrates a schematic diagram of a first portion of a first embodiment of a signal preprocessing channel of the first aspect of the recording module illustrated in FIG. 4, including a high-pass filter, and controllable-gain amplifier;

[0009] FIG. 5b illustrates a schematic diagram of a second portion of a first embodiment of the signal preprocessing channel of the first aspect of the recording module illustrated in FIG. 4, including a notch filter, and a low-pass filter;

[0010] FIG. 6a illustrates a schematic diagram of a second embodiment of a high-pass filter of the first aspect of the recording module illustrated in FIG. 4, without a shielding ground, used with an auscultatory sound-or-vibration sensor; FIG. 6b illustrates a schematic diagram of the second embodiment of the high-pass filter of the first aspect of the recording module illustrated in FIG. 4, without the shielding ground, but used with an ECG sensor;

[0011] FIG. 7a illustrates a schematic diagram of a third embodiment of the high-pass filter of the first aspect of the recording module illustrated in FIG. 4, with a shielding ground, used with an acoustic sensor;

[0012] FIG. 7b illustrates a schematic diagram of the third embodiment of the high-pass filter of the first aspect of the recording module illustrated in FIG. 4, with the shielding ground, used with an ECG sensor;

[0013] FIG. 8 illustrates a second schematic diagram of the first embodiment of the controllable-gain amplifier of the first aspect of the recording module illustrated in FIG. 4;

[0014] FIG. 9 illustrates a schematic diagram of an instrumentation amplifier used in the controllable-gain amplifier illustrated in FIG. 8;

[0015] FIG. 10 illustrates a schematic diagram of a second embodiment of a controllable-gain amplifier of the first aspect of the recording module illustrated in FIG. 4;

[0016] FIG. 11 illustrates a first block diagram of an analog-to-digital converter of the first aspect of the recording module illustrated in FIG. 4;

[0017] FIG. 12 illustrates a second block diagram of the analog-to-digital converter illustrated in FIG. 11;

[0018] FIG. 13 illustrates a block diagram of a second aspect of a recording module of the coronary-artery-disease detection system illustrated in FIG. 1;

[0019] FIG. 14 illustrates a band-pass filter of the second aspect of the recording module illustrated in FIG. 13;

[0020] FIG. 15 illustrates the core elements of the band-pass filter illustrated in FIG. 14;

[0021] FIG. 16 illustrates a block diagram of an analog-to-digital converter of the second aspect of the recording module illustrated in FIG. 13;

[0022] FIG. 17 illustrates a block diagram of a second aspect of a docking system of the coronary-artery-disease detection system illustrated in FIG. 1, in cooperation with a second aspect of a coronary artery disease detection system;

[0023] FIG. 18 illustrates a block diagram of a third aspect of a docking system of the coronary-artery-disease detection system illustrated in FIG. 1, in cooperation with a third aspect of a coronary artery disease detection system;

[0024] FIG. 19 illustrates an array of six auscultatory sound-or-vibration sensors of the coronary-artery-disease detection system illustrated in FIG. 1;

[0025] FIG. 20 illustrates the array of auscultatory sound-or-vibration sensors illustrated in FIG. 19 being placed over a corresponding array of sound generators, after which the auscultatory sound sensors are subjected to sound signals from corresponding sound generators in order to test the auscultatory sound sensors;

[0026] FIG. 21 illustrates a block diagram of the testing and subsequent use of an array of auscultatory sound sensors;

[0027] FIG. 22 illustrates a flow chart of a sensor-test acoustic-frequency waveform generation procedure; FIG. 23a illustrates a sensor-test acoustic-frequency waveform repetitively used to drive the sound generators when testing the plurality of auscultatory sound sensors during an associated auscultatory-sensor integrity-test procedure;

[0028] FIGS. 23b-23e illustrate repetitions of the sensor-test acoustic-frequency waveform used to drive the sound generators when testing the plurality of auscultatory sound sensors during an associated auscultatory-sensor integrity-test procedure;

[0029] FIG. 24 illustrates a flow chart of a first phase of an auscultatory-sensor integrity-test for integrity-testing the plurality of auscultatory sound sensors illustrated in FIG. 19 using the sound generators of a docking system as illustrated in FIG. 20, for the coronary-artery-disease detection system illustrated in FIGS. 1 and 21;

[0030] FIG. 25 illustrates frequency spectrum of the sensor-test acoustic-frequency waveform illustrated in FIG. 23a;

[0031] FIG. 26 illustrates a flow chart of a second phase of an auscultatory-sensor integrity-test procedure, which follows the first phase illustrated in FIG. 24;

[0032] FIG. 27 illustrates a block diagram of communication paths of the coronary-artery-disease detection system illustrated in FIG. 1;

[0033] FIG. 28 illustrates a WIFI communication link between the recording module and the docking system of the coronary-artery-disease detection system illustrated in FIG. 1, with the hotspot in the recording module;

[0034] FIG. 29 illustrates a WIFI communication link between the recording module and the docking system of the coronary-artery-disease detection system illustrated in FIG. 1, with the hotspot in the docking system;

[0035] FIG. 30 illustrates a WIFI communication link between the recording module and the docking system of the coronary-artery-disease detection system illustrated in FIG. 1, with the hotspot external of both the recording module and the docking system;

[0036] FIG. 31 illustrates a block diagram of dual-path communications between the recording module and the docking system of the coronary-artery-disease detection system illustrated in FIG. 1, with a WIFI path for real-time status and control, and a USB path for transferring data acquired by the associated auscultatory sound sensors;

[0037] FIG. 32 illustrates a block diagram of dual-path communications between the recording module and the docking system of the coronary-artery-disease detection system illustrated in FIG. 1, with a Bluetooth path for real-time status and control, and a USB path for transferring data acquired by the associated auscultatory sound sensors;

[0038] FIG. 33 illustrates a flowchart of a process implemented on the recording module, for establishing and using a link for Bluetooth communications;

[0039] FIG. 34 illustrates a flowchart of a process implemented on the docking system, for establishing and using a link for Bluetooth communications;

[0040] FIG. 35 illustrates a block diagram of single-path, USB-based communications between the recording module and the docking system of the coronary-artery-disease detection system illustrated in FIG. 1 for transferring data acquired by the associated auscultatory sound sensors from the recording module to the associated docking system;

[0041] FIG. 36 illustrates an accelerometer on the thorax of a test-subject during a respiration cycle of the test-subject;

[0042] FIG. 37a illustrates an overall perspective view an embodiment of the first aspect of a coronary artery disease detection system, configured as a mobile, roll-around workstation; FIG. 37b illustrates a fragmentary perspective view of a lower portion of the embodiment of the first aspect of a coronary artery disease detection system illustrated in FIG. 37a, illustrating the associated embedded computer system and AC power adapter;

[0043] FIG. 38 illustrates a perspective view an embodiment of the second aspect of a coronary artery disease detection system, configured as a portable, self-contained device; and FIG. 39 illustrates a perspective view an embodiment of the third aspect of a coronary artery disease detection system, configured as a wall-mounted system.

DESCRIPTION OF EMBODIMENT(S)

[0044] Referring to FIGS. 1 and 2a, a first aspect 10.1 of a coronary-artery-disease (CAD) detection system 10, 10.1 provides for detecting coronary artery disease of a test subject 12 from cardiovascular sounds or vibrations emitted from coronary arteries that become sufficiently obstructed so that the obstructions therein cause sound-emitting turbu-

lence in the flow of blood therethrough. The cardiovascular sounds are sensed by one or more auscultatory sound-or-vibration sensors 14, for example, a pair of sensor assemblies 16.1, 16.2, each with three auscultatory sound-or-vibration sensors 14, 14.1, 14.2, 14.3, or, more generally, an array 18 of auscultatory sound-or-vibration sensors 14, either mechanically coupled to one another or mechanically isolated from one another. For example, in one set of embodiments, the auscultatory sound-or-vibration sensors 14 are located above and proximate to the third 20^{3L}, 20^{3R}, fourth 20^{4L}, 20^{4R} and fifth 20^{5L}, 20^{5R}, intercostal spaces on the left and right side of the test subject 34, respectively, for the first 16.1 and second 16.2 sensor assemblies, respectively; or more generally, but not limited to, a set of three intercostal spaces—for example, ranging from the second to the fifth—at two different lateral locations—for example, two of the left 20^L, sternum 20_s and right 20^R lateral locations on the test subject 12, for example, as illustrated in FIG. 2b. For example, in accordance with a first aspect 14', each auscultatory sound-or-vibration sensor 14, 14' may be constructed and used as a passive device (i.e. not supplied with external power) in accordance with either U.S. Provisional Application No. 62/568,155 filed on 4 Oct. 2017, entitled AUSCULTATORY SOUND SENSOR, or U.S. patent application Ser. No. 14/152,004 filed on 4 Oct. 2018 entitled AUSCULTATORY SOUND-OR-VIBRATION SENSOR, each of which is incorporated herein by reference in its entirety, wherein each auscultatory sound-or-vibration sensor 14, 14' incorporates a metallic diaphragm disk incorporating a piezoelectric material bonded thereto and operatively coupled to a base rim of a housing provides for closing an open-ended cavity at a first end of the housing. In one aspect, plastic film adhesively bonded to at least one of an outer rim of the housing or an outer-facing surface of the disk provides for receiving an adhesive acoustic interface material to provide for coupling the housing to the skin of a test subject. In another aspect, an outer-facing surface of a base portion of the housing provides for receiving an adhesive acoustic interface material to provide for coupling the housing to the skin of a test subject, at least one inertial mass is operatively coupled to a central portion of the metallic diaphragm disk, and the opening in the first end of the housing is closed with a cover. Each auscultatory sound-or-vibration sensor 14, 14' is attached to the skin 22 of the test subject 12 with a layer of hydrogel material 24—or more generally, an adhesive acoustic-interface material 24'—that adhesively bonds the sensor to the skin 22 of the test subject 12, for example, so as to maintain the position of the auscultatory sound-or-vibration sensors 14, 14' on the thorax 26 of the test subject 12 when supported on a surface 25 that elevates the torso 26' of the test subject 12 at an inclination angle above horizontal—but generally, as close to upright (i.e. $\theta=90$ degrees) as can be accommodated by an associated adhesive acoustic-interface material 24' of the associated auscultatory sound-or-vibration sensors 14, 14.1, 14.2, 14.3 that provides for attachment thereof to the skin 22 of the test subject 12—for example, as illustrated in FIG. 3, at an angle of about 30 degrees above horizontal, which has been found to be beneficial for acquiring auscultatory sound signals associated with cardiovascular disease. The acoustic impedance of the hydrogel material 24—which is made primarily of water, having an acoustic impedance of 1.5×10^6 Kg/(m²*sec)—also provides for substantially matching the nominal 1.6×10^6 Kg/(m²*sec) acoustic impedance of the

skin. The auscultatory sound-or-vibration sensor **14**, **14'** may be adapted to incorporate an electrode **27** of an ECG sensor **28**, **28'**—a pair or plurality of which can provide for acquiring an associated electrographic signal—or alternatively, the coronary-artery-disease (CAD) detection system **10**, **10.1** may utilize a separate ECG sensor **28**, **28''**, either of which may be used to facilitate synchronization with the associated heart cycles. Generally, either style of ECG sensor **28**, **28'**, **28''** incorporates a plurality of electrodes **27**, for example, in one set of embodiments, a pair of signal electrodes **27**, **27^{+/-}** in cooperation with a ground electrode **27^o**, wherein, referring to FIG. **2a**, the signal electrodes **27**, **27^{+/-}** span the heart from diametrically-opposed quadrants of the torso **26'**, and the ground electrode **27^o** is located in a different quadrant, orthogonally displaced from a midpoint of a baseline connecting the signal electrodes **27**, **27^{+/-}**.

[0045] As used herein, the terms “auscultatory sound” and “auscultatory sound or vibration” are each intended to mean a sound or vibration originating from inside a human or animal organism as a result of the biological functioning thereof, for example, as might be generated by action of the heart, lungs, other organs, or the associated vascular system; and is not intended to be limited to a particular range of frequencies—for example, not limited to a range of frequencies or sound/vibration intensities that would be audible to a human ear,—but could include frequencies above, below, and in the audible range, and sound/vibration intensities that are too faint to be audible to a human ear. Furthermore, the terms “auscultatory-sound sensor” and “auscultatory sound-or-vibration sensor” are each intended to mean a sound or vibration sensor that provides for transducing auscultatory sounds or vibrations into a corresponding electrical or optical signal that can be subsequently processed, and is not limited to a particular mode of transduction.

[0046] The auscultatory sound-or-vibration sensors **14**, **14'** are operatively coupled—for example, by one or more cables or cable assemblies **30** between the auscultatory sound-or-vibration sensors **14**, **14'** and a magnetically-secured electrical connector **32**—to a recording module **34** that provides for preprocessing, and in some embodiments, locally storing, the auscultatory sound signals **36** that are transduced by the one or more auscultatory sound-or-vibration sensors **14**, **14'**. In some embodiments, the recording module **34** also provides for preprocessing, and in some embodiments, locally storing, an electrographic signal **38** generated by an associated ECG sensor **28**, **28'**, **28''**. The magnetically-secured electrical connector **32** is removably attached to the recording module **34** by a magnetic attraction therebetween, with associated permanent magnets incorporated in one or both of the magnetically-secured electrical connector **32** or the recording module **34**.

[0047] Referring also to FIG. **4**, in accordance with a first aspect **34.1** of a recording module **34**, **34.1**, each auscultatory sound signal **36** from each auscultatory sound-or-vibration sensor **14**, **14'**, and the electrographic signal **38** if acquired, are preprocessed by a separate signal preprocessing channel **40**, **40.1**, **40.2**, **40.3**, **40.4**, **40.5**, **40.6**, **40.7**—respectively for the auscultatory sound signals **36** and the electrographic signal **38**, respectively—that comprises an EMI protection circuit **42**, a high-pass filter **44**, an optional controllable gain amplifier **46**, a low-pass filter **48**—for example, a second order Butterworth fully-differential low-pass filter **48**, **48'**—and an analog-to-digital converter **50**. For example, the high-pass filter **44** may be of either first or

second order, with a cut-off frequency in the range of 3 to 15 Hz, for example, about 15 Hz for one set of embodiments. In one set of embodiments, the gain of the controllable gain amplifier **46** is controllable in **16** levels between about 88 and about 2500. Furthermore, in one set of embodiments, the low-pass filter **48** is a second-order Butterworth filter with a cut-off frequency in the range of 1 kHz to 2.5 kHz, for example, about 2 kHz.

[0048] For example, referring to FIG. **5a**, a first embodiment the high-pass filter **44**, **44'** to comprises first **44.1** and second **44.2** high-pass filters that span a controllable gain amplifier **46**, wherein the first high-pass filter **44.1** comprises a R-C high pass filter, for which the associated cut-off frequency $fc1$ is given by:

$$fc1 = \frac{1}{2\pi \cdot R87 \cdot C91}, \quad (1)$$

and the second high-pass filter **44.2** comprises a second order Butterworth Sallen-Key filter, for which the associated cut-off frequency $fc2$ is given by:

$$fc2 = \frac{1}{2\pi \cdot \sqrt{R101 \cdot R85 \cdot C94 \cdot C95}}. \quad (2)$$

[0049] The first high-pass filter **44.1** incorporates a balanced, differential input **52**, each leg of which comprises a series, first R-C network **54** feeding a parallel, second RC network **56**, the latter of which is in parallel with corresponding non-inverting **58.1** and inverting **58.2** inputs of an associated instrumentation amplifier **58** of the associated, below-described, first embodiment of the controllable gain amplifier **46**, **46.1**. The associated EMI protection circuit **42** comprises R-C network **R86-C85**.

[0050] Referring to FIG. **6a**, a second embodiment of the high-pass filter **44**, **44''** has a balanced, differential input **60**, each leg of which has the same impedance with respect to ground and is connected across a corresponding series R-C network **62** for which the corresponding differential input **60** thereto is applied to the associated capacitor **C1**. The junction **64** between the capacitor **C1** and the resistor **R1** of the series R-C network **62** is connected to a corresponding non-inverting input **66** of an associated corresponding operational amplifier **68.1**, **68.2**, and the remaining terminal of the resistor **68** is connected to ground **73**. Each of the inverting inputs **74** of the operational amplifiers **72.1**, **72.2** are interconnected through a resistor **RG0**, and also connected to a feedback resistor **R**. When used to preprocess an auscultatory sound signal **36** from an auscultatory sound-or-vibration sensor **14**, **14'**, the auscultatory sound signal **36** exclusively drives the balanced, differential input **60** of the high-pass filter **44**, **44''**.

[0051] A differential measurement system—such as the high-pass filter **44**, **44''** illustrated in FIG. **6a**—provides for rejecting a common-mode signal if the two-terminal source, the two-terminal source receiver, and the associated pair of conductors of the cable interconnecting the source and receiver, are each balanced, wherein each of the source and receiver are balanced if each of the source terminals has the same impedance to ground, each of the receiver terminals

has the same impedance to ground, and each of the pair of conductors of the cable has the same impedance to ground. [0052] However, for the high-pass filter 44, 44' illustrated in FIG. 6b, when used to preprocess an electrographic signal 38 from an ECG sensor 28, 28', 28'', the electrographic signal 38 applied to the differential input 60 is shunted by a resistance R_{BODY} of the body, so that the associated electrographic signal 38—across the equivalent resistance R_{BODY} shunting the output from the electrographic sensor 28—effectively acts as a single-ended signal, so as to provide for electronic noise on the different terminals of the high-pass filter 44, 44' to be different, and therefore not be completely rejected by the associated differential measurement system of the high-pass filter 44, 44'. For example, when an auscultatory sound-or-vibration sensor 14, 14' or an ECG sensor 28, 28', 28'' is attached to the skin 22 of a test subject 12, some conductive noise—for example, 60 Hz power line noise—may become superimposed on a differential analog input that does not have a shielding ground. The shielding ground is a reference point for the right and left ECG inputs which are balanced. Otherwise, there would be no reference, so the 2-wires ECG input would act like a single ended source.

[0053] Referring to FIGS. 7a and 7b, in a third embodiment of the high-pass filter 44, 44', that provides for a balanced, differential input 60—for either input from an auscultatory sound-or-vibration sensor 14, 14' as illustrated in FIG. 7a, or an input from an ECG sensor 28, 28', 28'' as illustrated in FIG. 7b—by coupling the circuit ground 76 to a body shielding ground 78 (i.e. the skin 22 of the test subject 12) through a series R-C circuit 80 comprising resistor R_{GND} in series with capacitor C_{GND} , the common-mode component of noise signal components I_{NOISE1} and I_{NOISE2} contaminating the first 60.1 and second 60.2 input terminals of the high-pass filter 44, 44' will be rejected by the associated differential measurement system of the high-pass filter 44, 44', and remaining unbalanced components of noise with be shorted to body shielding ground 78 through the series R-C circuit 80.

[0054] Accordingly, in one set of embodiments, the second embodiment of the high-pass filter 44, 44' is used for receiving and filtering a corresponding auscultatory sound signal 36 from a corresponding auscultatory sound-or-vibration sensor 14, 14', and the third embodiment of the high-pass filter 44, 44' is used for receiving and filtering a corresponding electrographic signal 38 from the ECG sensor 28, 28', 28''. The body shielding ground 78 can be located anywhere on the skin 22 of the test subject 12. In one set of embodiments, the connection of the body shielding ground 78 is made via a conductive plate on the bottom side of the recording module 34, 34.1 that rests upon the skin 22 of the test subject 12 during the test. When measuring electrographic signals 38 from the ECG sensor 28, 28', 28'', the body shielding ground 78 may be provided by an associated ground electrode 27' of the ECG sensor 28, 28', 28''.

[0055] Referring again to FIG. 5a, and referring to FIG. 8, a first embodiment 46.1 of a controllable gain amplifier 46, 46.1 comprises a differential-input instrumentation amplifier 82, for example, Texas Instruments INA188, a simplified schematic diagram of which is illustrated in FIG. 9, and which is described in Texas Instruments, “INA188 Precision, Zero-Drift, Rail-to-Rail Out, High-Voltage Instrumentation Amplifier,” SB0S632, September 2015, 40 pages, which is incorporated herein by reference in its entirety. The

non-inverting 58.1 and inverting 58.2 inputs of the differential-input instrumentation amplifier 82 are operatively coupled to the output of the first high-pass filter 44.1, and a single-ended output of the differential-input instrumentation amplifier 82 is operatively to a fixed-gain second operational amplifier 84, the latter of which is shared with the second high-pass filter 44.2. The INA188 differential-input instrumentation amplifier 82 has an effective amplification feedback resistance $R_{fd}=50$ k Ω , and the overall gain of the INA188 differential-input instrumentation amplifier 82 given by:

$$G = 1 + \frac{R_{fd}}{R_G} \quad (3)$$

wherein R_G is the effective resistance across the remaining two input terminals 58.3, 58.4 of the INA188 differential-input instrumentation amplifier 82. The controllable gain amplifier 46, 46.1 further comprises a fixed resistor R_{G0} across input terminals 58.3, 58.4 of the INA188 differential-input instrumentation amplifier 82, and further comprises an array of $N=4$ selectable resistors R_{G1} , R_{G2} , R_{G3} , R_{G4} , each of which is in series with a corresponding respective controllable analog switch SW1, SW2, SW3, SW4 under control of a corresponding, respective logic bit control signal C1, C2, C3, C4, wherein each series combination is in parallel with the fixed resistor R_{G0} across input terminals 58.3, 58.4 of the INA188 differential-input instrumentation amplifier 82. The resistance of each of the controllable analog switches SW1, SW2, SW3, SW4 in the ON state is negligible in comparison with the corresponding resistances of the associated selectable resistors R_{G1} , R_{G2} , R_{G3} , R_{G4} . The $N=4$ logic bit control signals C1, C2, C3, C4 provide for 16 different possible combinations, with a corresponding effective resistance across the input terminals 58.3, 58.4 of the INA188 differential-input instrumentation amplifier 82 ranging in value between R_{G0} and the parallel combination of all five resistors, i.e. $R_{G0} // R_{G1} // R_{G2} // R_{G3} // R_{G4}$. In general, for N selectable resistors, there would be $2N$ different possible values of effective resistance R_G . The resulting total effective gain of the controllable gain amplifier 46, 46.1 is then given by:

$$\text{Gain} = \left(1 + \frac{R_{fd}}{(R_{G0} // R_{G1} // R_{G2} // R_{G3} // R_{G4})} \right) \times \left(1 + \frac{R_2}{R_1} \right) \quad (4)$$

wherein the symbol “//R” means a parallel combination of that resistance with the remaining resistances if the corresponding controllable analog switch SW1, SW2, SW3, SW4 is activated, and means a parallel combination with an infinite resistance if the corresponding controllable analog switch SW1, SW2, SW3, SW4 is not activated.

[0056] Referring to FIG. 10, a second embodiment 46.2 of a controllable gain amplifier 46, 46.2 is similar to the above-described first embodiment 46.1, but with the INA188 differential-input instrumentation amplifier 82 replaced with corresponding first 86.1 and second 86.2 operational amplifiers interconnected as a differential amplifier, without the associated fixed gain second operational amplifier 84.

[0057] Referring to FIG. 5b, the output of the controllable gain amplifier 46, 46.1 and the second high-pass filter 44.2 is then coupled to a 60 Hz notch filter 88 to remove AC power-associated noise, the output of which is coupled to the second order Butterworth fully-differential low-pass filter 48, 48', for which the cut-off frequency of the latter is given by:

$$f_c = \frac{1}{2\pi \cdot \sqrt{2 \cdot R83 \cdot R89 \cdot C84 \cdot C92}} \quad (5)$$

[0058] Referring again to FIG. 4, and referring to FIGS. 11 and 12, in accordance with the first aspect 34.1 of the recording module 34, 34.1, the differential output of the second order Butterworth fully-differential low-pass filter 48, 48' is then coupled to an associated first aspect 50.1 of an analog-to-digital converter 50, 50.1, which is implemented with a Cirrus Logic, CS5368-CQZ 8-Channel analog-to-digital converter described in Cirrus Logic, "114 dB, 192 kHz, 8-Channel A/D Converter," DS624F5, 2014, 42 pages, which is incorporated herein by reference in its entirety, wherein each signal preprocessing channel 40, 40.1, 40.2, 40.3, 40.4, 40.5, 40.6, 40.7 is processed, in parallel and synchronously, by a corresponding separate 24-bit analog-to-digital converter 50, 50.1.

[0059] Referring also to FIG. 13, a second aspect 34.2 of a recording module 34, 34.2 is substantially the same as the above-described first aspect recording module 34, 34.1, except that the first 44.1 and second 44.2 high pass filters, controllable gain amplifier 46, 46.1, second order Butterworth fully-differential low-pass filter 48, 48'—that collectively function as a first aspect 90.1 of a band-pass filter 90, 90.1—and the associated first aspect analog-to-digital converter 50, 50.1, are replaced by a combination of a fixed gain, full-differential band-pass filter 90, 90.2 and a programmable-gain, second aspect analog-to-digital converter 50, 50.2 incorporating a Programmable Gain Amplifier (PGA).

[0060] More particularly, referring to FIGS. 14 and 15, the fixed gain, full-differential band-pass filter 90, 90.2 comprises a balanced differential input and differential output configuration, each leg thereof incorporating a single operational amplifier 92, for example, an Analog Devices ADA4522-2 operational amplifier 92, 92', with an associated input-stage second-order high-pass filter network 94 associated with the input of the fixed gain, full-differential band-pass filter 90, 90.2, and an associated output-stage second-order low-pass filter network 96 associated with the output of the fixed gain, full-differential band-pass filter 90, 90.2, wherein the Analog Devices ADA4522-2 operational amplifier 92, 92' is described in Analog Devices, "55 V, EMI Enhanced, Zero Drift, Ultralow Noise, Rail-to-Rail Output Operational Amplifiers," D13168-0-9/17(F), 2017, 33 pages, which is incorporated herein by reference in its entirety. For example, the fixed gain, full-differential band-pass filter 90, 90.2 illustrated in FIG. 14 has an application-specific gain, depending upon the type of signal being processed.

[0061] The associated set of high-pass cut-off frequencies f_{c1H} , f_{c2H} of the fixed gain, full-differential band-pass filter 90, 90.2 are given by:

$$f_{c1H} = \frac{1}{2\pi \cdot R4 \cdot C4}, \quad (6)$$

$$f_{c2H} = \frac{1}{2\pi \cdot R10 \cdot C5}, \quad (7)$$

and the associated set of low-pass cut-off frequencies f_{c1L} , f_{c2L} of the fixed gain, full-differential band-pass filter 90, 90.2 given by:

$$f_{c1L} = \frac{1}{2\pi \cdot R10 \cdot C7}, \quad (7)$$

$$f_{c2L} = \frac{1}{2\pi \cdot R1 \cdot C6}, \quad (8)$$

[0062] The associated EMI protection circuit 42 comprises R-C network R3-C2.

[0063] Referring to FIG. 15, the fixed gain, full-differential band-pass filter 90, 90.2 comprises cascaded high-pass and low-pass passive filter stages, which together in cooperation with the operational amplifier 92, 92' provide for a relatively wide pass band. The first stage of the filter is a two-pole high-pass stage 94' that comprises the capacitors C_{H1} , C_{H2} and the resistors R_{H1} , R_G to block any DC biasing and low frequency signals from the source. The second stage of the filter is a two-pole low-pass stage 96' that comprises the capacitors C_{L1} , C_{L2} and the resistors R_{L1} , R_G . The full differential filter design both provides for a high common-mode rejection ratio (CMRR), and provides for a relatively flat asymmetrical pass band frequency response with a first portion thereof accounting for the low-pass response and the remaining second portion thereof accounting for the high-pass response. The bandwidth of the fixed gain, full-differential band-pass filter 90, 90.2 is the difference between these upper and lower -3 dB points, i.e. the difference between the higher corner cut-off frequency f_H and the lower corner frequency cut-off frequency f_L . For example, for a fixed gain, full-differential band-pass filter 90, 90.2 with -3 dB cut-off frequencies f_L , f_H at 15 Hz and 1 kHz, respectively, the associated pass-band frequency range would be 15 Hz to 1 kHz.

[0064] The component parameters of the circuit elements of the fixed gain, full-differential band-pass filter 90, 90.2 are adapted to the associated sensor that is the source of the signal being processed thereby. For example, in accordance with a first embodiment 90.2', the fixed gain, full-differential band-pass filter 90, 90.2, 90.2' is adapted to cooperate with a first aspect, passive, auscultatory sound-or-vibration sensor 14, 14', with capacitors C_m or C4 and C8 each having a value of 1 microfarad, with capacitors C_{H2} or C5 having a value of 22 microfarads, and with the gain resistor R_G or R_{10} having a value of 2 KOhm so as to provide for a fixed gain of 33 dB to satisfy the requirements of a particular first aspect, passive, auscultatory sound-or-vibration sensor 14, 14', resulting in a 6 Hz cut-off frequency of the high-pass filter, so that the associated band-pass filter has a pass band of 6 Hz to 2 kHz. As another example, in accordance with a second embodiment 90.2", the fixed gain, full-differential band-pass filter 90, 90.2, 90.2" is adapted to cooperate with a microphone or background noise sensor 97 that provides for sensing the background sounds in the room in which the signals are gathered, so as to provide for prospectively

compensating for a prospective adverse effect thereof on the auscultatory sound signals 36 that might otherwise interfere with the detection of cardiovascular disease, or might otherwise contribute to a false detection thereof. More particularly, for example, in one embodiment, the audio signal 97' from the microphone or background noise sensor 97 is processed by a corresponding signal preprocessing channel 40, 40.8 of the fixed gain, full-differential band-pass filter 90, 90.2, 90.2'" for which the single-ended input (+) to which the microphone or background noise sensor 97 is connected to a +2 volt DC supply through a pull-up resistor R_{PULL} , the remaining input (-) is connected to signal ground, with capacitors C_m or C_4 having a value of 0.22 microfarads, with capacitors C_{H2} or C_5 having a value of 2.2 microfarads, and with the gain resistor R_G or R_{10} having a value of 2 KOhm so as to provide for a fixed gain of 33 dB to satisfy the requirements of the microphone or background noise sensor 97, resulting in a 70 Hz cut-off frequency of the high-pass filter, so that the associated band-pass filter has a pass band of 70 Hz to 2 kHz, which provides for filtering what can be relatively prevalent acoustic noise in frequencies below 70 Hz that are otherwise outside a range of interest.

[0065] As yet another example, in accordance with a third embodiment 90.2"', the fixed gain, full-differential band-pass filter 90, 90.2, 90.2'" is adapted to cooperate with a set of second aspect 14", active auscultatory sound-or-vibration sensors 14, 14"', each of which requires power to operate, for example, each second aspect auscultatory sound-or-vibration sensor 14, 14" comprising an accelerometer incorporating an integrated circuit that requires power to operate. More particularly, for example, in one embodiment, the associated corresponding signal preprocessing channel(s) 40, 40.1, 40.2, 40.3, 40.4, 40.5, 40.6 of the fixed gain, full-differential band-pass filter 90, 90.2, 90.2'" each incorporate a 2 milliamperere current source provided by an associated current regulator 98 powered from a +12.7 volt DC supply, with capacitors C_m or C_4 and C_8 having a value of 1 microfarad, with capacitors C_{H2} or C_5 having a value of 22 microfarads, and with the gain resistor R_G or R_{10} having a value of 4.99 KOhms so as to provide for a fixed gain of 26 dB to satisfy the requirements of a particular first aspect, passive, auscultatory sound-or-vibration sensor 14, 14', resulting in a 4 Hz cut-off frequency of the high-pass filter, so that the associated band-pass filter has a pass band of 4 Hz to 2 kHz. Alternatively, in another embodiment, a gain resistor R_G or R_{10} having a value of 14.3 KOhms so as to provide for a fixed gain of 7.5 dB to satisfy the requirements of a different first aspect, passive, auscultatory sound-or-vibration sensor 14, 14', results in a 3 Hz cut-off frequency of the high-pass filter, so that the associated band-pass filter would have a pass band of 3 Hz to 2 kHz.

[0066] Compared to the fixed gain, full-differential band-pass filter 90, 90.2 illustrated in FIG. 15, the third embodiment high-pass filter 44, 44'" illustrated in FIG. 7b is configured as a band-pass filter with a pass band of 3 Hz to 2 kHz, without the associated high-pass filter provided for by capacitor C_{H2} illustrated in FIG. 15, and for which the cut-off frequency of the high-pass filter provided for by capacitor C_m is 3 Hz, in order to accommodate relatively low frequency components of an associated electrographic signal 38, which are in greater proportion than in corresponding auscultatory sound signals 36.

[0067] Referring again to FIG. 13, and referring to FIG. 16, in accordance with the second aspect 34.2 of the recording module 34, 34.2, the differential output of the fixed gain, full-differential band-pass filter 90, 90.2 is then coupled to an associated second aspect 50.2 of an analog-to-digital converter 50, 50.2, which, for example, in one embodiment is implemented with a Texas Instruments, ADS1299IPAG 8-Channel analog-to-digital converter as described in Texas Instruments, "ADS1299-x Low-Noise 5-, 6-, 8-Channel, 24-Bit, Analog-to-Digital Converter for EEG and Biopotential Measurements," SBAS499C, July 2012, Revised January 2017, 81 pages, the latter of which is incorporated herein by reference in its entirety, wherein each signal preprocessing channel 40, 40.1, 40.2, 40.3, 40.4, 40.5, 40.6, 40.7, 40.8 is to be processed, in parallel and synchronously, by a corresponding separate 24-bit analog-to-digital converter 50, 50.2, the latter of which also incorporates a separate, separately-controllable associated controllable-gain amplifier 46, 46.3 for each signal preprocessing channel 40, 40.1, 40.2, 40.3, 40.4, 40.5, 40.6, 40.7.

[0068] Generally, the high-pass filters 44, 44', 44"', 44'" or the input-stage second-order high-pass filter network 94 of the associated band-pass filters 90, 90.1, 90.2, 90.2', 90.2"', 90.2'" are configured with a 3 dB cut-off frequency in the range of 3 Hz to 15 Hz to process an auscultatory sound signal 36 from an auscultatory sound-or-vibration sensor 14, 14', 14"', 14'" 1 Hz-3 Hz when used to process an electrographic signal 38 from an ECG sensor 28, 28', 28"', 28'" and 65 Hz-75 Hz when used to process an audio signal 97' from a microphone or background noise sensor 97; and the low-pass filters 48, 48' or the output-stage second-order low-pass filter network 96 of the associated band-pass filters 90, 90.1, 90.2, 90.2', 90.2"', 90.2'" are configured with a 3 dB cut-off frequency in the range of 500 Hz to 2.5 kHz.

[0069] Referring again to FIGS. 1, 4 and 13, the recording module 34, 34.1, 34.2 is under control of a micro-processing-unit (MPU) module 99 that provides for communicating with an associated docking system 100 via either a wireless interface 102 or a USB interface 104 that are either incorporated in, or peripherally connected to, the micro-processing-unit (MPU) module 99. The micro-processing-unit (MPU) module 99 further either incorporates, or interfaces with, associated memory 106, for example, either one or more of RAM, flash memory, EEPROM or Secure Digital Memory (i.e. an SD memory card). The micro-processing-unit (MPU) module 99 interfaces with a data & clock management module 108—for example, in one set of embodiments, implemented with a Field Programmable Gate Array (FPGA)—that provides for controlling the sampling process (e.g. the associated sampling clock) of the analog-to-digital converter 50, 50.1, 50.2 and for formatting the data therefrom and transmitting this formatted data to the micro-processing-unit (MPU) module 99 for subsequent transmittal to the docking system 100.

[0070] In one set of embodiments, for example, incorporating a wireless interface 102, the recording module 34, 34.1, 34.2 is powered by a battery 110, for example, a nominally 3.7 V lithium-ion battery 110', the charge of which is under control of a battery management and monitoring system 112 responsive to current, voltage and temperature, for example, by an STC3100 integrated circuit from STMicroelectronics, as described in STMicroelectronics, "STC3100 Battery monitor IC with Coulomb counter/gas gauge," January 2009, 21 pages, the latter of which is

incorporated herein by reference in its entirety. The battery management and monitoring system 112 is programmable, and readable, through an I2C interface. Alternatively, the battery management and monitoring system 112 may be integrated with the battery 110, for example, using an RRC1120 Li-ion Semi-Smart Battery Pack from RRC Power Solutions. The battery 110 is charged by an associated battery charger 114 from an external +5V power supply via an associated power jack 116. Power from the battery 110 is provided through a power switch 118 under control of the battery management and monitoring system 112, to one or more DC-DC power supplies 120 that provide power to the electronics of the recording module 34, 34.1, 34.2, wherein the recording module 34, 34.1, 34.2 is automatically powered down if the voltage of the of the battery 110, 110' is less than a threshold, for example, less than 3.3 V.

[0071] Alternatively, in another set of embodiments, for example, incorporating a USB interface 104, the recording module 34, 34.1, 34.2 is powered directly from the +5 volt power supply of the USB interface 104, thereby precluding a need for a battery 110, 110', battery management and monitoring system 112, or battery charger 114, which may be therefore be excluded embodiments that are connected to the docking system 100, 100.1, 100.2 exclusively via a USB interface 104. For example, in some hospital environments, a wireless interface 102 would not be suitable because of interference with other wireless-based systems. In systems incorporating both wireless 102 and USB 104 interfaces, a battery bypass switch 121 provides for switching from battery power to USB power when the USB interface 104 is active.

[0072] Referring again to FIG. 1, a first aspect 100.1 of a docking system 100, 100.1 is implemented with a Windows-based computer—for example, an Intel NUC—embedded computer system 122 that interfaces with an LCD touch-screen display 124, both of which are powered from a power-management board 126 that receives power from an AC-powered AC/DC power adapter 128. A WIFI router 130 operatively coupled to the embedded computer system 122 provides for communicating at with the recording module 34, 34.1, 34.2, so as to provide for controlling the operation thereof responsive to operator inputs via the LCD touch-screen display 124, the latter of which also provides for displaying the resulting data that may be received either via a WIFI-wireless interface 102, 132 via the WIFI router 130, or via a separate USB interface 104. The power-management board 126 also provides power for charging the battery 110, 110' of the recording module 34, 34.1, 34.2 via an associated power jack 116.

[0073] Referring to FIG. 17, a second aspect 10.2 of a coronary-artery-disease (CAD) detection system 10, 10.2 incorporates a second aspect 100.2 of the docking system 100, 100.2, the latter of which incorporates an embedded computer system 122, for example, a COM Express Compact Module 122, 122', with associated peripherals connected thereto via corresponding connectors (shown as boxes in FIG. 17 on the periphery of the docking system 100, 100.2). For example, in one set of embodiments, a +5V power jack 116', for example, embodied in USB-connector, provides for powering or charging the recording module 34, 34.1, 34.2, that latter of which communicates with the docking system 100, 100.2 either exclusively via either a WIFI-wireless interface 102, 132 using an associated USB-connected WIFI or Bluetooth® adapter 138 or a USB

interface 104; or via a combination of the two. Alternatively, the recording module 34, 34.1, 34.2 may be either wired directly to the docking system 100, 100.2 via a connectorless USB interface 104, or connected via a USB connector 116' to a cable that extends directly from the docking system 100, 100.2. An LCD touch-screen display 124 connected to the docking system 100, 100.2 provides for controlling the recording module 34, 34.1, 34.2 and processing and displaying results therefrom. The docking system 100, 100.2 further incorporates a solid-state disk 139 for storing data and programs.

[0074] For example, the COM Express Compact Module 122, 122' performs high-speed functions of the docking system 100, 100.2, for example, including control of, or communication with: 1) USB ports for the recording module 34, 34.1, 34.2, WIFI or Bluetooth® adapter 138, a wireless access point, etc.; 2) Gigabit Ethernet; 3) Audio codec that supports sensor integrity test signal output, input from a microphone or background noise sensor 97, and headphone output; 4) HDMI and DP interfaces for LCD monitors; 5) high performance processor for GUI and DAA; 6) SSD for storage of the operating system, application software and recorded test subject data; and 7) communication with an associated Microprocessor Control Unit (MCU) 140 via a UART port for hardware control and status. The Microprocessor Control Unit (MCU) 140 performs low-speed functions of the docking system 100, 100.2, for example, including the following monitoring, control and communication activities: 1) monitoring all voltage and current of various voltage regulators; 2) monitoring the board temperature; 3) controlling the LCD backlight brightness; 4) detecting the open or close status of the lid of the docking system 100, 100.2; 5) controlling the LED indicator for system status; 6) monitoring the power button status; 7) controlling and monitoring the fan speed; 8) accessing an optional EEPROM memory chip; 9) communicating with the COM Express Compact Module 122, 122' via a UART port for hardware control and status; and 10) accessing an ID chip 141 for the serial number, wherein the ID chip 141 provides a unique, factory-lasered 64-bit serial number that can be used to identify the hardware and system in the associated data that is captured by the docking system 100, 100.2 from the recording module 34, 34.1, 34.2.

[0075] Referring to FIG. 18, a third aspect 10.2 of a coronary-artery-disease (CAD) detection system 10, 10.3 incorporates an alternative third aspect 100.3 of the docking system 100, 100.3, the latter of which incorporates a panel PC 142 that provides for an integrated computer and LCD touchscreen display system that further incorporates a wireless/Bluetooth® interface 142.1, USB interfaces 142.2, 142.3 and a power interface 142.4, wherein the associated LCD touchscreen display system provides for controlling the recording module 34, 34.1, 34.2 via the wireless/Bluetooth® interface 142.1, and processing and displaying results received therefrom via one of the USB interfaces 142.2.

[0076] Referring to FIGS. 1, and 17-22, the docking system 100, 100.1, 100.2, 100.3 further incorporates a sensor-integrity-test sub-system 144 comprising an array 145 of a plurality of sound generators 146—at least equal in number to the number of auscultatory sound-or-vibration sensors 14—for testing the array 18 of auscultatory sound-or-vibration sensors 14 in order to detect either a failure or degradation of any of the auscultatory sound-or-vibration

sensors 14. For example, in accordance with one test procedure, the auscultatory sound-or-vibration sensors 14 are tested both prior to, and following, a gathering of auscultatory sound-or-vibration signals 36 from a test subject 12, so as to mitigate against inconvenience to the test subject 12 that would otherwise result if one or more of the auscultatory sound-or-vibration sensors 14 was defective.

[0077] For example, in accordance with one set of embodiments, each of the plurality of sound generators 146 of the array 145 comprises a piezoelectric sound generator 146, 146' similar in construction to the piezoelectric sensor disk of the auscultatory sound-or-vibration sensors 14, as described in U.S. Provisional Application No. 62/568,155 incorporated herein by reference, but with an AC signal applied across the associated piezoelectric material, which causes the piezoelectric sensor disk to vibrate, and causes the associated metallic diaphragm disk substrate to act as a speaker to generate sound. Each piezoelectric sound generator 146, 146' is located at the base of a well 148 that is sized to receive a corresponding auscultatory sound-or-vibration sensor 14 to be tested and align each auscultatory sound-or-vibration sensor 14 with a corresponding sound generator 146, 146', with the metallic diaphragm disk substrate of the piezoelectric sound generator 146, 146' facing upwards so as to abut the polyester film layer covering the piezoelectric sensor disk of the corresponding auscultatory sound-or-vibration sensor 14 when the latter is placed in the corresponding well 148 when performing an integrity-test thereof.

[0078] In accordance with one set of embodiments, the piezoelectric sound generators 146, 146' are picked as a batch of transducers with similar frequency response (± 5 dB from median) within the frequency range of 0 to 2 kHz.

[0079] For example, referring to FIG. 19, in accordance with one set of embodiments, there are six auscultatory sound-or-vibration sensors 14—designated S1 to S6—in the array 18 of auscultatory sound-or-vibration sensors 14 to be tested, the latter of which, referring to FIG. 21, are attached to the recording module 34, 34.1 which is operated normally during the sensor-integrity test, and which is in wireless or USB communication with the associated docking system 100, 100.1, 100.2, 100.3, so as to provide for preprocessing and then transmitting the associated resulting acoustic signals 36' from the auscultatory sound-or-vibration sensors 14—recorded during the test—to the docking system 100, 100.1, 100.2, 100.3 for analysis of the integrity-test results. The acoustic signals 36' acquired during the integrity test are filtered by the band-pass filter 90 of the recording module 34, 34.1, 34.2, the same as for auscultatory sound signals 36 when gathered from a test subject 12.

[0080] In accordance with the second aspect 100.2 of the docking system 100, 100.2, the piezoelectric sound generators 146, 146' are driven either by an amplified analog signal 150' from an audio amplifier 152 that is driven by an analog signal 150 from an audio CODEC 154, or directly from the audio CODEC 154 the latter of which is driven by a digital signal 156 from the COM Express Compact Module 122, 122' based upon an associated test signal that is stored on a file, for example, on the associated solid-state disk 139, responsive to an associated integrity-test software application running on the COM Express Compact Module 122, 122'. In accordance with the third aspect 100.3 of the docking system 100, 100.3, the piezoelectric sound generators 146, 146' are driven from an audio signal generator card

158 by an amplified analog signal 160' from an audio amplifier 152 driven by an analog signal 160 from a digital-to-analog converter 162 driven by a micro-controller 164 either responsive to a digital signal waveform 166 stored on flash memory 168, or generated in real time by the micro-controller 164, responsive to a stored program on EEPROM 170. For example, in accordance with one set of embodiments, the associated amplified analog signal 150', 160' from the audio amplifier 152 is applied in parallel to each of the piezoelectric sound generators 146, 146' of the array 145. In one set of embodiments, the audio signal generator card 158 is powered from an AC-powered 19 VDC power supply 172, wherein the power therefrom is also coupled to the panel PC 142. In one set of embodiments, the panel PC 142 is grounded to earth ground 174 by connection to the audio signal generator card 158. Alternatively, if another source of earth ground 174 is established for the panel PC 142, or if the panel PC 142 is configured so as to not require an earth ground 174, then the 19 VDC power supply 172 could be connected directly to the panel PC 142, rather than via the audio signal generator card 158. Furthermore, the second USB interface 142.3 on the panel PC 142 may be used to provide +5 VDC to the audio signal generator card 158 by connection to a USB port 176 on the audio signal generator card 158, the latter of which can also be used to receive associated control signals from the panel PC 142 that provide for initiating the sensor integrity test.

[0081] Referring to FIGS. 21-26, a sensor-test acoustic-frequency waveform W—generated in accordance with an associated sensor-test acoustic-frequency waveform generation procedure 2200—is applied to the sound generators 146, 146' in accordance with an associated auscultatory-sensor integrity-test procedure 2400 that is run on the embedded computer system 122, 122' or panel PC 142 of the docking system 100, 100.1, 100.2, 100.3. The auscultatory-sensor integrity-test procedure 2400 provides for generating and applying either an analog signal 150, or an amplified analog signal 150', 160', to drive the sound generators 146, 146'; provides for receiving the resulting acoustic signals 36' from the array 18 of auscultatory sound-or-vibration sensors 14 via the recording module 34, 34.1, 34.2; and provides for determining whether any of the auscultatory sound-or-vibration sensors 14 have failed or diminished, or whether there are any breaks in the associated wiring of the auscultatory sound-or-vibration sensors 14 or problems with the connection of the auscultatory sound-or-vibration sensors 14 to the recording module 34, 34.1, 34.2.

[0082] More particularly, referring to FIG. 22, the amplified analog signal 150', 160' applied to the sound generators 146, 146' during the auscultatory-sensor integrity-test procedure 2400 is generated as a composite of a plurality of pure tones. For example, in accordance with one set of embodiments, in step (2202), a set of four sinusoidal tones of a corresponding respective four different nominal test frequencies F'_A , F'_B , F'_C , F'_D , each of equal magnitude, within an expected relevant range of frequencies of the auscultatory sound signals 36 that may be associated with coronary-artery disease. For example, in one set of embodiments, the four tones are at sinusoidal nominal test frequencies of $F'_A=500$ Hz, $F'_B=650$ Hz, $F'_C=800$ Hz and $F'_D=1100$ Hz.

[0083] Looking ahead, for each auscultatory sound-or-vibration sensor 14, a sample of N_{FFT} samples of the associated acoustic signal 36'—generated responsive to an

acoustic stimulus by the piezoelectric sound generators **146**, **146'** responsive to the sensor test acoustic-frequency waveform W , and sampled at a sampling frequency of F_S Hz, for example, 24 kHz—are transformed from the time domain to the frequency domain by a Short Time Fourier Transform (STFT) process, wherein specific frequency components in the frequency domain output are then analyzed to assess the integrity of the auscultatory sound-or-vibration sensors **14**. Accordingly, in order to mitigate against spectral leakage by an associated non-windowed N_{FFT} -point Fast Fourier Transform (FFT) algorithm, the actual test frequencies F_A, F_B, F_C, F_D underlying the corresponding N_{FFT} -point time-domain sensor test acoustic-frequency waveform W are adapted so that each has an integral number of associated cycles there-within, or equivalently, so that each test frequency F_A, F_B, F_C, F_D is an integral multiple of the sampling frequency F_S divided by the number of samples N_{FFT} in the time-domain sensor test acoustic-frequency waveform W , i.e., an integral multiple of F_S/N_{FFT} . Accordingly, in step (2204), this condition may be satisfied by the following test frequencies F_A, F_B, F_C, F_D that are relatively close to the nominal test frequencies F'_A, F'_B, F'_C, F'_D :

$$F_A = \text{Round}\left(\frac{N_{FFT} \cdot F'_A}{F_S}, 0\right) \cdot \frac{F_S}{N_{FFT}}; \quad (9a)$$

$$F_B = \text{Round}\left(\frac{N_{FFT} \cdot F'_B}{F_S}, 0\right) \cdot \frac{F_S}{N_{FFT}}; \quad (9b)$$

$$F_C = \text{Round}\left(\frac{N_{FFT} \cdot F'_C}{F_S}, 0\right) \cdot \frac{F_S}{N_{FFT}}; \text{ and} \quad (9c)$$

$$F_D = \text{Round}\left(\frac{N_{FFT} \cdot F'_D}{F_S}, 0\right) \cdot \frac{F_S}{N_{FFT}}. \quad (9d)$$

[0084] Accordingly, for the nominal test frequencies $F'_A=500$ Hz, $F'_B=650$ Hz, $F'_C=800$ Hz and $F'_D=1100$ Hz, and for $N_{FFT}=4096$ points, the corresponding resulting actual test frequencies (and number of cycles in the sensor test acoustic-frequency waveform W auscultatory sound-or-vibration sensors **14**) are respectively, $F_A=498.046875$ Hz (85 cycles), $F_B=650.390625$ Hz (111 cycles), $F_C=802.734375$ Hz (137 cycles) and $F_D=1101.5625$ Hz (188 cycles), wherein each test frequency F_A, F_B, F_C, F_D is evenly divisible by $F_S/N_{FFT}=5.859375$ Hz

[0085] Then, in step (2206), the result of which is illustrated in FIG. 23a, a normalized N_{FFT} -point time-domain sensor test acoustic-frequency waveform W is then generated by summing the individual frequency components, as follows, for $0 \leq i < N_{FFT}$:

$$W(i) = \frac{\sin\left(\frac{2 \cdot \pi \cdot F_A \cdot i}{F_S}\right) + \sin\left(\frac{2 \cdot \pi \cdot F_B \cdot i}{F_S}\right) + \sin\left(\frac{2 \cdot \pi \cdot F_C \cdot i}{F_S}\right) + \sin\left(\frac{2 \cdot \pi \cdot F_D \cdot i}{F_S}\right)}{4}. \quad (10)$$

[0086] Then, in step (2208), the resulting sensor test acoustic-frequency waveform W —or, equivalently, the associated set of parameters by which it is generated—is stored in the docking system **100**, **100.1**, **100.2**, **100.3** for

subsequent use in driving the plurality of sound generators **146** during the auscultatory-sensor integrity-test procedure **2400**.

[0087] Referring to FIG. 24, in step (2402), successive, respective occurrences of the N_{FFT} -point time-domain sensor test acoustic-frequency waveform W —for example, as shown in FIGS. 23b-23e, illustrating the last four of N_F total occurrences,—are applied to the plurality of sound generators **146** in acoustic communication with the corresponding plurality of auscultatory sound-or-vibration sensors **14** adjacent thereto when placed in the wells **148** of the docking system **100**, **100.1**, **100.2**, **100.3**. For example, in accordance with the third aspect docking system **100**, **100.3**, the sensor test acoustic-frequency waveform W stored on the flash memory **168** is successively and repetitively played back to the digital-to-analog converter **162**, the resulting analog signal **160** is amplified by the associated audio amplifier **152**, and the resulting amplified analog signal **160'** is applied to the plurality of sound generators **146**.

[0088] Then, in step (2404), the docking system **100**, **100.1**, **100.2**, **100.3** causes the recording module **34**, **34.1**, **34.2** to preprocess and record ΔT_{TEST} seconds of acoustic signals **36'**, for example, a duration of about five seconds, sufficient to span a plurality of N_{FFT} -point frames of the acoustic signals **36'**, each recorded at a sampling rate of N_s Hz, resulting in a total of $N_s \times \Delta T_{TEST}$ samples. Then, in step **2406**, the recorded acoustic signals **36'** of a time-series A —containing $N_s \times \Delta T_{TEST}$ samples—are transferred to the docking system **100**, **100.1**, **100.2**, **100.3**, for example, via either a wireless **102** or USB **104** interface.

[0089] Then, in step **2408**, the acoustic signals **36'** from each of the plurality of auscultatory sound-or-vibration sensors **14** are processed, beginning with step (2410), by initializing a pointer i_0 to point to the beginning of the first N_{FFT} -point frame of the acoustic signal **36'** to be processed—i.e. the acoustic data **36'**—, and by initializing a frame counter k to a value of zero. Then, in step (2412), a pointer i_{MAX} is set to point to the last sample of the corresponding N_{FFT} -point frame of the acoustic signal **36'** to be processed, i.e. to a value of $i_0 \pm N_{FFT} - 1$. Then, in step (2414), if the end of time-series A has not been reached, or less than T_{MAX} seconds of data has been processed, for example, in one set of embodiments, less than three seconds, then in step (2416), a Short Term Fourier Transform (STFT) of the N_{FFT} -point frame of acoustic data **36'** is calculated, i.e. an N_{FFT} -point Fast Fourier Transform (FFT) of one N_{FFT} -point frame subset of the entire acoustic signal **36'** time series, and the values of the resulting series are each squared and logarithmically expressed in dB to give a spectral series PA providing a measure of the power of the acoustic data **36'** as a function of frequency. Since the FFT of a real signal is conjugate symmetric, only the first $N_{FF}/2+1$ values are returned in the spectral series PA , covering the frequency range 0 to $F_S/2$. The Short Term Fourier Transform (STFT) provides for resolutions in both time and frequency, with a time resolution of N_{FF}/F_S , and a frequency resolution of F_S/N_{FF} , which for $N_{FF}=4096$ and $F_S=24$ kHz, are 0.17 sec and 5.86 Hz, respectively. For example, FIG. 25 illustrates a plot of the spectral series PA for one of the N_{FFT} -point frames of acoustic data **36'**, which exhibits peaks at each of the test frequencies F_A, F_B, F_C, F_D .

[0090] Then, in step (2418), the power of each of the test frequencies F_A , F_B , F_C , F_D is stored as the k^{th} value in a corresponding test-frequency-power array P_A , P_B , P_C , P_D , i.e.:

$$P_A(k) = PA\left(F_A / \frac{F_S}{N_{FFT}}\right) = PA(85); \quad (11a)$$

$$P_B(k) = PB\left(F_B / \frac{F_S}{N_{FFT}}\right) = PA(111); \quad (11b)$$

$$P_C(k) = PC\left(F_C / \frac{F_S}{N_{FFT}}\right) = PA(137); \text{ and} \quad (11c)$$

$$P_D(k) = PD\left(F_D / \frac{F_S}{N_{FFT}}\right) = PA(188). \quad (11d)$$

[0091] Then, in step (2420), the frame counter k is incremented, and in step (2422), the pointer i_0 is updated to point to the beginning of the next N_{FFT} -point frame of acoustic data $36'$ in the acoustic signal $36'$ to be processed, adjacent in time to the just-processed previous N_{FFT} -point frame of acoustic data $36'$, after which the process of step (2408) repeats, beginning with step (2412) until the condition of step (2414) is satisfied, after which the total number of frames N_{Frame} is set equal to the last value of the frame counter k , and, from step (2426), the test-frequency-power arrays P_A , P_B , P_C , P_D are analyzed in a second phase 2600 of the auscultatory-sensor integrity-test procedure 2400, to determine whether or not any of the auscultatory sound-or-vibration sensors 14 might be defective.

[0092] More particularly, referring to FIG. 26, in step (2602), the average spectral power \bar{P}_A , \bar{P}_B , \bar{P}_C , \bar{P}_D at each of the corresponding test frequencies F_A , F_B , F_C , F_D is calculated by summing the corresponding spectral powers from each of the N_{FFT} -point frames of acoustic data $36'$, and dividing by the total number of frames N_{Frame} , as follows:

$$\bar{P}_A = \frac{\sum_{k=0}^{N_{Frame}-1} P_A(k)}{N_{Frame}}; \quad (12a)$$

$$\bar{P}_B = \frac{\sum_{k=0}^{N_{Frame}-1} P_B(k)}{N_{Frame}}; \quad (12b)$$

$$\bar{P}_C = \frac{\sum_{k=0}^{N_{Frame}-1} P_C(k)}{N_{Frame}}; \text{ and} \quad (12c)$$

$$\bar{P}_D = \frac{\sum_{k=0}^{N_{Frame}-1} P_D(k)}{N_{Frame}}. \quad (12d)$$

[0093] Then, if, in step (2604), any of the average spectral power values \bar{P}_A , \bar{P}_B , \bar{P}_C , \bar{P}_D exceeds a first threshold Threshold_{GOOD} , and if, in step (2606), each of the average spectral power values \bar{P}_A , \bar{P}_B , \bar{P}_C , \bar{P}_D exceeds a second threshold Threshold_{BAD} , then, in step (2608), the associated auscultatory sound-or-vibration sensor 14 is indicated as having passed the test. Otherwise, from either steps (2604) or (2606), in step (2610), the associated auscultatory sound-

or-vibration sensor 14 is indicated as having failed the test. The first Threshold_{GOOD} and second Threshold_{BAD} thresholds are derived empirically by testing set of known "good" auscultatory sound-or-vibration sensors 14 with a set of sound generators 146 in a particular configuration (i.e. placement and spacing of the auscultatory sound-or-vibration sensors 14 to sound generators 146), which is then replicated for subsequent arrays 145 of a sound generators 146. For example, in one set of embodiments, the first threshold Threshold_{GOOD} is -35 dB, and the second threshold Threshold_{BAD} is -50 dB.

[0094] The auscultatory-sensor integrity-test procedure 2400 is performed both prior to placing the array 18 of auscultatory sound-or-vibration sensors 14 on the thorax 26 of the test subject 12, and after collection of auscultatory sound signals 36 has been completed for a given test of the test subject 12 by the coronary-artery-disease (CAD) detection system 10.

[0095] The auscultatory-sensor integrity-test procedure 2400 is performed with each auscultatory sound-or-vibration sensors 14 of the array 18 seated in a corresponding well 148 in the docking system 100, 100.1, 100.2, 100.3, abutting a corresponding sound generator 146, 146' of the associated array 145 of sound generators 146, 146'.

[0096] Referring to FIG. 27, the coronary-artery-disease (CAD) detection system 10, 10.1, 10.2 incorporates a bi-directional communication link 178—for example, either or both a wireless interface 102, 132 or a USB interface 104—between the recording module 34, 34.1, 34.2 and the docking system 100, 100.1, 100.2, 100.3, so as to provide for the docking system 100, 100.1, 100.2, 100.3 to cause the recording module 34, 34.1, 34.2 to commence recording auscultatory sound signals 36 from the array 18 of auscultatory sound-or-vibration sensors 14—and possibly also to commence recording an ECG signal 38 from the ECG sensor 28, 28', 28" or an audio signal 97 from a microphone or background noise sensor 97—and, in some embodiments, to provide for the docking system 100, 100.1, 100.2, 100.3 to control the controllable gain of the controllable-gain amplifier 46, 46.1, 46.2, 46.3 in the recording module 34, 34.1, 34.2. The communication link 178 between the recording module 34, 34.1, 34.2 and the docking system 100, 100.1, 100.2, 100.3 also provides for the recording module 34, 34.1, 34.2 to transmit associated real-time status information, and to transmit the recorded auscultatory sound signals 36, and possibly also the recorded ECG signal 38 or the recorded audio signal 97, therefrom, to the docking system 100, 100.1, 100.2, 100.3 for subsequent processing and display. For example, in accordance with various embodiments, the wireless interface 102, 132 may utilize either WIFI or Bluetooth® protocols and associated hardware.

[0097] Referring to FIGS. 28-30, a WIFI communication link 180 controlled by a WIFI hotspot 182 in communication with a pair of WIFI clients 184, 184.1, 184.2 provides for the WIFI clients 184.1, 184.2 to communicate with one another via the WIFI hotspot 182, for example, over the ISM band of frequencies, for example, in one set of embodiments, at 2.4 GHz, for example, either using antennas embedded in one or more of the recording module 34, 34.1, 34.2 and the docking system 100, 100.1, 100.2, or using one or more external antennas, for example, one or more monopole antennas. Each of the recording module 34, 34.1, 34.2 and the docking system 100, 100.1, 100.2 incorporates one of

two aspects **186.1**, **186.2** of an associated WIFI adapter **186**, i.e. either a first aspect **186.1** of which is configured as just a WIFI client **184**, or a second aspect **186.2** of which is configured as both a and WIFI hotspot **182** a WIFI client **184**. For example, referring to FIG. **28**, the WIFI adapter **186**, **186.2** in the recording module **34**, **34.1**, **34.2** is configured as both a first WIFI client **184**, **184.1** and the WIFI hotspot **182**, and the WIFI adapter **186**, **186.1** in the docking system **100**, **100.1**, **100.2** is configured as just a second WIFI client **184**, **184.2**. Alternatively, referring to FIG. **29**, the WIFI adapter **186**, **186.2** in the docking system **100**, **100.1**, **100.2** is configured as both the first WIFI client **184**, **184.1** and the WIFI hotspot **182**, and the WIFI adapter **186**, **186.1** in the recording module **34**, **34.1**, **34.2** is configured as just the second WIFI client **184**, **184.2**. Yet further alternatively, referring to FIG. **30**, the WIFI hotspot **182** is external of both the recording module **34**, **34.1**, **34.2** and the docking system **100**, **100.1**, **100.2**, wherein the WIFI adapter **186**, **186.1** in the recording module **34**, **34.1**, **34.2** is configured as just the first WIFI client **184**, **184.1** and the WIFI adapter **186**, **186.1** in the docking system **100**, **100.1**, **100.2** is configured as just the second WIFI client **184**, **184.2**. In each of the above configurations illustrated in FIGS. **28-30**, each of WIFI clients **184**, **184.1**, **184.2** is in communication with the WIFI hotspot **182** that provides for communicating data, status and control information therethrough.

[0098] In accordance with a first aspect, all of the data communicated between the recording module **34**, **34.1**, **34.2** and the docking system **100**, **100.1**, **100.2** is via the WIFI communication link **180**.

[0099] Alternatively, referring to FIG. **31**, in accordance with a second aspect, a physical, USB communication link **188**, **104** is used to communicate non-real-time data—for example, recorded auscultatory sound signals **36**, or a recorded ECG signal **38**, stored in memory **106** on the recording module **34**, **34.1**, **34.2** during the associated data collection process—from the recording module **34**, **34.1**, **34.2** to the docking system **100**, **100.1**, **100.2** following the data collection process, wherein the remaining status and control information is communicated wirelessly between the recording module **34**, **34.1**, **34.2** and the docking system **100**, **100.1**, **100.2** via the WIFI communication link **180**, resulting in a substantially reduced overall demand on the capacity or resources of the WIFI communication link **180**. For example, in some cases, other devices using the same WIFI channel may cause unacceptable delays in wireless communication between the recording module **34**, **34.1**, **34.2** and the docking system **100**, **100.1**, **100.2** when communicating over the WIFI communication link **18**.

[0100] Yet further alternatively, referring to FIG. **32**, in accordance with a third aspect, a physical, USB communication link **188**, **104** is used to communicate non-real-time data—for example, recorded auscultatory sound signals **36**, or a recorded ECG signal **38**, stored in memory **106** on the recording module **34**, **34.1**, **34.2** during the associated data collection process—from the recording module **34**, **34.1**, **34.2** to the docking system **100**, **100.1**, **100.2**, **100.3** following the data collection process, and the remaining status and control information is communicated wirelessly between the recording module **34**, **34.1**, **34.2** and the docking system **100**, **100.1**, **100.2**, **100.3** via a peer-to-peer Bluetooth® communication link **190**, the latter of which would typically not have sufficient capacity to handle communication of the auscultatory sound signals **36**, or an ECG signal **38** in real

time, but which would have the capacity to handle communication of the associated real-time data. For example, FIGS. **33** and **34** respectively illustrate processes on the recording module **34**, **34.1**, **34.2** and the docking system **100**, **100.1**, **100.2**, **100.3**, respectively, for establishing a peer-to-peer Bluetooth® communication link **190** therebetween.

[0101] Yet further alternatively, referring to FIG. **35**, in accordance with a fourth aspect, a physical, USB communication link **188**, **104** is used exclusively to communicate all data between the recording module **34**, **34.1**, **34.2** and the docking system **100**, **100.1**, **100.2**, **100.3**, thereby precluding interference from external wireless signals, and providing for the recording module **34**, **34.1**, **34.2** to be powered directly from the docking system **100**, **100.1**, **100.2**, **100.3**, thereby precluding the need for a battery **110**, **110'** and associated charging and battery-power-management system in the recording module **34**, **34.1**, **34.2**.

[0102] Referring to FIGS. **1** and **36** the coronary-artery-disease (CAD) detection system **10** may further incorporate an accelerometer **192** operatively coupled to the thorax **26** of the test-subject **12** to provide an associated acceleration signal responsive to the motion of the thorax **26**. With the test-subject **12** lying on their back, inclined at an angle θ , for example, as illustrated in FIG. **3**, the associated acceleration signal operatively coupled to recording module **34**, **34.1**, **34.2**, and processed by a corresponding signal preprocessing channel **40**, **40.9** thereof—for example, in one set of embodiments, similar to that used for a second aspect, active auscultatory sound-or-vibration sensor **14**, **14'**,—may be twice integrated either in recording module **34**, **34.1**, **34.2** or the docking system **100**, **100.1**, **100.2**, **100.3** to generate a measure of the peak-to-peak displacement ΔY of the thorax **26**, which if greater than a threshold would be indicative of breathing by the test-subject **12**.

[0103] Referring to FIGS. **37a** and **37b**, an embodiment of the first aspect coronary-artery-disease (CAD) detection system **10**, **10.1** is configured as a mobile, roll-around workstation, wherein the associated embedded computer system **122** (e.g. a Windows-based Intel NUC computer) and AC-powered AC/DC power adapter **128** are attached near the base of a post **198** that depends from a mobile instrument stand **200**. The associated sound generators **146** and wells **148** of the sensor-integrity-test sub-system **144** of the docking system **100**, **100.1** incorporated in a top, inner surface of a housing **202**, the latter of which is located on a work surface depending from the post **198** at a comfortable working height for the operator. The housing **202** provides for convenient storage of the recording module **34**, **34.1**, **34.2**, associated auscultatory sound-or-vibration sensors **14**, **14'**, **14''**, and associated supplies, and incorporates a hinged cover **204** to provide for protecting the contents therein, and also houses the associated power-management board **126**, the latter of which is operatively coupled to and receives power from the AC-powered AC/DC power adapter **128**. A keyboard **206** and mouse **208** are provided on associated work surfaces to facilitate operator input to the docking system **100**, **100.1**. For example, in one set of embodiments, an Intel NUC embedded computer system **122** provides for a Windows-based computing environment. Either an LCD touch-screen display **124**, or a conventional display **124'**, is supported from the post **198** at a comfortable eye height of the operator, the latter being sufficient in view of the keyboard **206** and mouse **208** being available for operator

input in cooperation with the Windows-based Intel NUC computer of the embedded computer system 122.

[0104] Referring to FIG. 38, an embodiment of the second aspect coronary-artery-disease (CAD) detection system 10, 10.2 is configured as a portable, self-contained device, with all the associated components of the associated docking system 100, 100.2 enclosed in an associated housing 210 that is adapted with a handle 212 for carrying, with the associated sound generators 146 and wells 148 of the sensor-integrity-test sub-system 144 of the associated docking system 100, 100.2 incorporated in an top, inner surface of the housing 210, the latter of which also provides for convenient storage of the recording module 34, 34.1, 34.2, associated auscultatory sound-or-vibration sensors 14, 14', 14", and associated supplies, and utilizes the associated LCD touch-screen display 124 as a hinged cover to provide for protecting the contents therein.

[0105] Referring to FIG. 39, an embodiment of the third aspect coronary-artery-disease (CAD) detection system 10, 10.3 is configured as a wall-mounted system, with the associated wall-mounted panel PC 142 providing for both display and touch-screen-initiated control, and with the associated audio signal generator card 158 and sensor-integrity-test sub-system 144 of the associated docking system 100, 100.1 incorporated in an associated housing 214 that also provides for convenient storage of the recording module 34, 34.1, 34.2, associated auscultatory sound-or-vibration sensors 14, 14', 14", and associated supplies, wherein the housing 214 may be either wall mounted or portable, and in the latter case, possibly wall stowed when not in use. If wall mounted, the associated wells 148 in the housing 214 are adapted—for example, with a friction fit—to provide for retaining the associated auscultatory sound-or-vibration sensors 14, 14', 14" therein during an integrity test thereof.

[0106] While specific embodiments have been described in detail in the foregoing detailed description and illustrated in the accompanying drawings, those with ordinary skill in the art will appreciate that various modifications and alternatives to those details could be developed in light of the overall teachings of the disclosure. It should be understood, that any reference herein to the term “or” is intended to mean an “inclusive or” or what is also known as a “logical OR”, wherein when used as a logic statement, the expression “A or B” is true if either A or B is true, or if both A and B are true, and when used as a list of elements, the expression “A, B or C” is intended to include all combinations of the elements recited in the expression, for example, any of the elements selected from the group consisting of A, B, C, (A, B), (A, C), (B, C), and (A, B, C); and so on if additional elements are listed. Furthermore, it should also be understood that the indefinite articles “a” or “an”, and the corresponding associated definite articles “the” or “said”, are each intended to mean one or more unless otherwise stated, implied, or physically impossible. Yet further, it should be understood that the expressions “at least one of A and B, etc.”, “at least one of A or B, etc.”, “selected from A and B, etc.” and “selected from A or B, etc.” are each intended to mean either any recited element individually or any combination of two or more elements, for example, any of the elements from the group consisting of “A”, “B”, and “A AND B together”, etc. Yet further, it should be understood that the expressions “one of A and B, etc.” and “one of A or B, etc.” are each intended to mean any of the recited

elements individually alone, for example, either A alone or B alone, etc., but not A AND B together. Furthermore, it should also be understood that unless indicated otherwise or unless physically impossible, that the above-described embodiments and aspects can be used in combination with one another and are not mutually exclusive. Accordingly, the particular arrangements disclosed are meant to be illustrative only and not limiting as to the scope of the invention, which is to be given the full breadth of any claims that are supportable by the specification and drawings, and any and all equivalents thereof.

What is claimed is:

1. A recording module for processing at least one electronic auscultatory sound signal from a corresponding at least one auscultatory sound-or-vibration sensor operatively coupled to a portion of the skin of a test subject, comprising:
 - a. a corresponding auscultatory sound-signal processing channel in correspondence with the at least one electronic auscultatory sound signal of said at least one electronic auscultatory sound signal, wherein said corresponding auscultatory sound-signal processing channel provides for receiving said at least one electronic auscultatory sound signal from the corresponding at least one auscultatory sound-or-vibration sensor of said at least one auscultatory sound-or-vibration sensor, and each said corresponding auscultatory sound-signal processing channel comprises:
 - i. a high-pass filter portion comprising either a first electronic differential-input high-pass filter having a 3 dB cut-off frequency in the range of 3 Hz to 15 Hz, or a first differential-input high-pass filter portion of an electronic band-pass filter having a 3 dB cut-off frequency in the range of 3 Hz to 15 Hz, wherein said at least one electronic auscultatory sound signal is operatively coupled to either a differential input of said first electronic differential-input high-pass filter or a differential input of said first differential-input high-pass filter portion of said electronic band-pass filter;
 - ii. an amplifier portion comprising an electronic differential-input amplifier associated with either said first electronic differential-input high-pass filter or said first differential-input high-pass filter portion of said electronic band-pass filter;
 - iii. a low-pass filter portion comprising either an electronic low-pass filter, or a low-pass filter portion of said electronic band-pass filter, wherein said electronic low-pass filter or said low-pass filter portion of said electronic band-pass filter is operatively coupled to an output of said electronic differential-input amplifier; and
 - iv. an analog-to-digital converter portion operatively coupled to an output of either said electronic low-pass filter or said electronic band-pass filter, wherein said analog-to-digital converter portion provides for converting said output of either said electronic low-pass filter or said electronic band-pass filter to digital form; and
 - b. a communications interface operatively coupled to an output of said analog-to-digital converter portion, wherein said communications interface provides for transmitting at least one digital signal generated by said analog-to-digital converter portion to a device external of said recording module.

2. A recording module for processing at least one electronic auscultatory sound signal from a corresponding at least one auscultatory sound-or-vibration sensor operatively coupled to a portion of the skin of a test subject as recited in claim 1, wherein said high-pass filter portion comprises a pair of first high-pass filter input circuits in cooperation with a pair of inputs of said electronic differential-input amplifier, said electronic differential-input amplifier comprises either a common first operational amplifier or a corresponding pair of first operational amplifiers, each first high-pass filter input circuit of said pair of first high-pass filter input circuits comprises a first capacitor and a first resistor, a first terminal of said first capacitor is operatively coupled to said at least one electronic auscultatory sound signal, a second terminal of said first capacitor is operatively coupled to a node that is operatively coupled to a corresponding input of said electronic differential-input amplifier, a first terminal of said first resistor is operatively coupled to said node, and a second terminal of said first resistor is operatively coupled to a circuit ground.

3. A recording module for processing at least one electronic auscultatory sound signal from a corresponding at least one auscultatory sound-or-vibration sensor operatively coupled to a portion of the skin of a test subject as recited in claim 2, wherein said high-pass filter portion further comprises a second resistor and a second capacitor, said second resistor is in series with said first capacitor, and said second capacitor is in parallel with said first resistor.

4. A recording module for processing at least one electronic auscultatory sound signal from a corresponding at least one auscultatory sound-or-vibration sensor operatively coupled to a portion of the skin of a test subject as recited in claim 2, wherein said high-pass filter portion further comprises a second high pass filter circuit in cooperation with a second operational amplifier,

5. A recording module for processing at least one electronic auscultatory sound signal from a corresponding at least one auscultatory sound-or-vibration sensor operatively coupled to a portion of the skin of a test subject as recited in claim 4, wherein an input of said second operational amplifier is operatively coupled to an output of said electronic differential-input amplifier. and said circuit ground is operatively coupled to the skin of the test subject via a series RC network.

6. A recording module for processing at least one electronic auscultatory sound signal from a corresponding at least one auscultatory sound-or-vibration sensor operatively coupled to a portion of the skin of a test subject as recited in claim 5, wherein said circuit ground is operatively coupled to the skin of the test subject via a ground conductor on a surface of said recording module in contact with said skin of said test subject.

7. A recording module for processing at least one electronic auscultatory sound signal from a corresponding at least one auscultatory sound-or-vibration sensor operatively coupled to a portion of the skin of a test subject as recited in claim 1, wherein said electronic differential-input amplifier is configured with a variable gain, and said variable gain is responsive to an external signal from said device external of said recording module, responsive to said at least one digital signal generated by said recording module.

8. A recording module for processing at least one electronic auscultatory sound signal from a corresponding at least one auscultatory sound-or-vibration sensor operatively

coupled to a portion of the skin of a test subject as recited in claim 7, further comprising a plurality of resistors and a corresponding plurality of electronically-controllable analog switches, wherein each electronically-controllable analog switch of said plurality of electronically-controllable analog switches provides for controlling an operative coupling a corresponding resistor to a pair of nodes operatively coupled to said electronic differential-input amplifier, wherein when said electronically-controllable analog switch is activated responsive to said external signal, said corresponding resistor is connected electrically in parallel with said pair of nodes, and when said electronically-controllable analog switch is deactivated responsive to said external signal, the resistance across said pair of nodes is unaffected by said corresponding resistor.

9. A recording module for processing at least one electronic auscultatory sound signal from a corresponding at least one auscultatory sound-or-vibration sensor operatively coupled to a portion of the skin of a test subject as recited in claim 1, wherein said analog-to-digital converter portion incorporates a variable-gain amplifier, and a gain of said variable-gain amplifier is responsive to an external signal from said device external of said recording module, responsive to said at least one digital signal generated by said recording module.

10. A recording module for processing at least one electronic auscultatory sound signal from a corresponding at least one auscultatory sound-or-vibration sensor operatively coupled to a portion of the skin of a test subject as recited in claim 1, wherein said communications interface comprises a USB interface, wherein said recording module is powered from said USB interface.

11. A recording module for processing at least one electronic auscultatory sound signal from a corresponding at least one auscultatory sound-or-vibration sensor operatively coupled to a portion of the skin of a test subject as recited in claim 1, wherein said communications interface comprises a wireless interface, further comprising a battery that provides for powering said recording module.

12. A recording module for processing at least one electronic auscultatory sound signal from a corresponding at least one auscultatory sound-or-vibration sensor operatively coupled to a portion of the skin of a test subject as recited in claim 1, wherein said at least one auscultatory sound-or-vibration sensor is powered by said recording module.

13. A recording module for processing at least one electronic auscultatory sound signal from a corresponding at least one auscultatory sound-or-vibration sensor operatively coupled to a portion of the skin of a test subject as recited in claim 1, wherein said electronic low-pass filter, or said low-pass filter portion of said electronic band-pass filter, of each said corresponding auscultatory-sound-signal-processing channel has a 3 dB cut-off frequency in the range of 500 Hz to 2.5 KHz.

14. A recording module for processing at least one electronic auscultatory sound signal from a corresponding at least one auscultatory sound-or-vibration sensor operatively coupled to a portion of the skin of a test subject as recited in claim 13, wherein said electronic low-pass filter, or said low-pass filter portion of said electronic band-pass filter, of each said corresponding auscultatory-sound-signal-processing channel has a 3 dB cut-off frequency in the range of 1 kHz to 2.5 KHz.

15. A recording module for processing at least one electronic auscultatory sound signal from a corresponding at least one auscultatory sound-or-vibration sensor operatively coupled to a portion of the skin of a test subject as recited in claim **1**, wherein said recording module further provides for processing an electrographic signal from a corresponding ECG sensor operatively coupled to a corresponding portion of said skin of said test subject, further comprising a corresponding electrographic-signal-processing channel in correspondence with said ECG sensor, wherein said corresponding electrographic-signal-processing channel provides for receiving said electrographic signal from said ECG sensor, and said corresponding electrographic-signal-processing channel comprises:

- a. a high-pass filter portion comprising either a first electronic differential-input high-pass filter having a 3 dB cut-off frequency in the range of 1 Hz to 3 Hz, or a first differential-input high-pass filter portion of an electronic band-pass filter having a 3 dB cut-off frequency in the range of 1 Hz to 3 Hz, wherein said electrographic signal is operatively coupled to either a differential input of said first electronic differential-input high-pass filter or a differential input of said first differential-input high-pass filter portion of said electronic band-pass filter;
- b. an amplifier portion comprising an electronic differential-input amplifier associated with either said first electronic differential-input high-pass filter or said first differential-input high-pass filter portion of said electronic band-pass filter;
- c. a low-pass filter portion comprising either an electronic low-pass filter, or a low-pass filter portion of said electronic band-pass filter, wherein said electronic band-pass filter or said low-pass filter portion of said electronic band-pass filter is operatively coupled to an output of said electronic differential-input amplifier; and
- d. an analog-to-digital converter portion operatively coupled to an output of either said electronic low-pass filter or said electronic band-pass filter, wherein said analog-to-digital converter portion provides for converting said output of either said electronic low-pass filter or said electronic band-pass filter to digital form, wherein said communications interface operatively coupled to an output of said analog-to-digital converter portion.

16. A recording module for processing at least one electronic auscultatory sound signal from a corresponding at least one auscultatory sound-or-vibration sensor operatively coupled to a portion of the skin of a test subject as recited in claim **15**, wherein said high-pass filter portion comprises a pair of first high-pass filter input circuits in cooperation with a pair of inputs of said electronic differential-input amplifier, said electronic differential-input amplifier comprises either a common first operational amplifier or a corresponding pair of first operational amplifiers, each first high-pass filter input circuit of said pair of first high-pass filter input circuits comprises a first capacitor and a first resistor, a first terminal of said first capacitor is operatively coupled to said electrographic signal, a second terminal of said first capacitor is operatively coupled to a node that is operatively coupled to a corresponding input of said electronic differential-input amplifier, a first terminal of said first resistor is operatively coupled to said node, a second termi-

nal of said first resistor is operatively coupled to a circuit ground, and said circuit ground is operatively coupled to a ground electrode of said ECG sensor applied to the skin of the test subject, via a series RC network.

17. A recording module for processing at least one electronic auscultatory sound signal from a corresponding at least one auscultatory sound-or-vibration sensor operatively coupled to a portion of the skin of a test subject as recited in claim **15**, wherein said electronic low-pass filter, or said low-pass filter portion of said electronic band-pass filter, of said corresponding electrographic-signal-processing channel has a 3 dB cut-off frequency in the range of 500 Hz to 2.5 KHz.

18. A recording module for processing at least one electronic auscultatory sound signal from a corresponding at least one auscultatory sound-or-vibration sensor operatively coupled to a portion of the skin of a test subject as recited in claim **17**, wherein said electronic low-pass filter, or said low-pass filter portion of said electronic band-pass filter, of said corresponding electrographic-signal-processing channel has a 3 dB cut-off frequency in the range of 1 kHz to 2.5 KHz.

19. A recording module for processing at least one electronic auscultatory sound signal from a corresponding at least one auscultatory sound-or-vibration sensor operatively coupled to a portion of the skin of a test subject as recited in claim **1**, wherein said recording module further provides for processing a background sound signal from a corresponding microphone, further comprising a corresponding background-sound-signal-signal-processing channel in correspondence with said microphone, wherein said corresponding background-sound-signal-signal-processing channel provides for receiving said background sound signal from said microphone, and said corresponding background-sound-signal-signal-processing channel comprises:

- a. a high-pass filter portion comprising either a first electronic differential-input high-pass filter having a 3 dB cut-off frequency in the range of 65 Hz to 75 Hz, or a first differential-input high-pass filter portion of an electronic band-pass filter having a 3 dB cut-off frequency in the range of 65 Hz to 75 Hz, wherein said background sound signal is operatively coupled to either a differential input of said first electronic differential-input high-pass filter or a differential input of said first differential-input high-pass filter portion of said electronic band-pass filter;
- b. an amplifier portion comprising an electronic differential-input amplifier associated with either said first electronic differential-input high-pass filter or said first differential-input high-pass filter portion of said electronic band-pass filter;
- c. a low-pass filter portion comprising either an electronic low-pass filter, or a low-pass filter portion of said electronic band-pass filter, wherein said electronic band-pass filter or said low-pass filter portion of said electronic band-pass filter is operatively coupled to an output of said electronic differential-input amplifier; and
- d. an analog-to-digital converter portion operatively coupled to an output of either said electronic low-pass filter or said electronic band-pass filter, wherein said analog-to-digital converter portion provides for converting said output of either said electronic low-pass filter or said electronic band-pass filter to digital form,

wherein said communications interface operatively coupled to an output of said analog-to-digital converter portion.

20. A recording module for processing at least one electronic auscultatory sound signal from a corresponding at least one auscultatory sound-or-vibration sensor operatively coupled to a portion of the skin of a test subject as recited in claim **19**, wherein said electronic low-pass filter, or said low-pass filter portion of said electronic band-pass filter, of said corresponding background-sound-signal-signal-processing channel has a 3 dB cut-off frequency in the range of 500 Hz to 2.5 KHz.

21. A recording module for processing at least one electronic auscultatory sound signal from a corresponding at least one auscultatory sound-or-vibration sensor operatively coupled to a portion of the skin of a test subject as recited in claim **20**, wherein said electronic low-pass filter, or said low-pass filter portion of said electronic band-pass filter, of said corresponding background-sound-signal-signal-processing channel has a 3 dB cut-off frequency in the range of 1 kHz to 2.5 KHz.

22. A method of acquiring signals from a test subject to be used for assessing the cardiovascular health of the test subject, comprising:

- a. providing for operatively coupling at least one auscultatory sound signal from a corresponding at least one auscultatory sound-or-vibration sensor to a corresponding at least one auscultatory sound signal-processing channel of a recording module, wherein said at least one auscultatory sound signal-processing channel provides for transforming said at least one auscultatory sound signal to a corresponding at least one processed auscultatory sound signal through a method comprising:
 - i. operatively coupling said at least one auscultatory sound signal to a differential input of either a corresponding high-pass filter having a 3 dB cut-off frequency in the range of 3 Hz to 15 Hz, or a corresponding high-pass filter portion of a band-pass filter having a 3 dB cut-off frequency in the range of 3 Hz to 15 Hz;
 - ii. filtering said at least one auscultatory sound signal with either said corresponding high-pass filter or said corresponding high-pass filter portion of said band-pass filter;
 - iii. amplifying said at least one auscultatory sound signal with a corresponding amplifier having an amplification gain;
 - iv. filtering said at least one auscultatory sound signal with a corresponding low-pass filter, or a corresponding low-pass filter portion of said band-pass filter; and
 - v. converting an output of said at least one auscultatory sound signal-processing channel to digital form so as to generate a corresponding digital-output signal; and
- b. transferring at least one said corresponding digital-output signal to a device external of the recording module.

23. A method of acquiring signals from a test subject to be used for assessing the cardiovascular health of the test subject as recited in claim **22**, wherein said corresponding low-pass filter, or said corresponding low-pass filter portion

of said band-pass filter, used to filter said at least one auscultatory sound signal has a 3 dB cut-off frequency in the range of 500 Hz to 2 KHz.

24. A method of acquiring signals from a test subject to be used for assessing the cardiovascular health of the test subject as recited in claim **23**, wherein said corresponding low-pass filter, or said corresponding low-pass filter portion of said band-pass filter, used to filter said at least one auscultatory sound signal has a 3 dB cut-off frequency in the range of 1 kHz to 2 KHz.

25. A method of acquiring signals from a test subject to be used for assessing the cardiovascular health of the test subject as recited in claim **22**, further comprising:

- a. providing for operatively coupling an electrographic signal from an ECG sensor operatively coupled to the test subject to a corresponding electrographic signal-processing channel of said recording module, wherein said electrographic signal-processing channel provides for transforming said electrographic signal to a corresponding processed electrographic signal through a method comprising:
 - i. operatively coupling said electrographic signal to a differential input of either a corresponding high-pass filter having a 3 dB cut-off frequency in the range of 1 Hz to 3 Hz, or a corresponding high-pass filter portion of a band-pass filter having a 3 dB cut-off frequency in the range of 1 Hz to 3 Hz;
 - ii. filtering said electrographic signal with either said corresponding high-pass filter or said corresponding high-pass filter portion of said band-pass filter;
 - iii. amplifying said electrographic signal with a corresponding amplifier having an amplification gain;
 - iv. filtering said electrographic signal with a corresponding low-pass filter, or a corresponding low-pass filter portion of said band-pass filter; and
 - v. converting an output of said electrographic signal-processing channel to digital form so as to generate a corresponding digital-output signal; and
- b. transferring at least one said corresponding digital-output signal to said device external of said recording module.

26. A method of acquiring signals from a test subject to be used for assessing the cardiovascular health of the test subject as recited in claim **25**, wherein said corresponding low-pass filter, or said corresponding low-pass filter portion of said band-pass filter, used to filter said electrographic signal has a 3 dB cut-off frequency in the range of 500 Hz to 2 KHz.

27. A method of acquiring signals from a test subject to be used for assessing the cardiovascular health of the test subject as recited in claim **26**, wherein said corresponding low-pass filter, or said corresponding low-pass filter portion of said band-pass filter, used to filter said electrographic signal has a 3 dB cut-off frequency in the range of 1 kHz to 2 KHz.

28. A method of acquiring signals from a test subject to be used for assessing the cardiovascular health of the test subject as recited in claim **22**, further comprising:

- a. providing for operatively coupling a background sound signal from a microphone located in a same room as the test subject to a corresponding background-sound signal-processing channel of said recording module, wherein said background-sound signal-processing channel provides for transforming said background

sound signal to a corresponding processed background sound signal through a method comprising:

- i. operatively coupling said background sound signal to a differential input of either a corresponding high-pass filter having a 3 dB cut-off frequency in the range of 65 Hz to 75 Hz, or a corresponding high-pass filter portion of a band-pass filter having a 3 dB cut-off frequency in the range of 65 Hz to 75 Hz;
- ii. filtering said background sound signal with either said corresponding high-pass filter or said corresponding high-pass filter portion of said band-pass filter;
- iii. amplifying said background sound signal with a corresponding amplifier having an amplification gain;
- iv. filtering said background sound signal with a corresponding low-pass filter, or a corresponding low-pass filter portion of said band-pass filter; and

- v. converting an output of said background-sound signal-processing channel to digital form so as to generate a corresponding digital-output signal; and
- b. transferring at least one said corresponding digital-output signal to said device external of said recording module.

29. A method of acquiring signals from a test subject to be used for assessing the cardiovascular health of the test subject as recited in claim **28**, wherein said corresponding low-pass filter, or said corresponding low-pass filter portion of said band-pass filter, used to filter said background sound signal has a 3 dB cut-off frequency in the range of 500 Hz to 2 KHz.

30. A method of acquiring signals from a test subject to be used for assessing the cardiovascular health of the test subject as recited in claim **29**, wherein said corresponding low-pass filter, or said corresponding low-pass filter portion of said band-pass filter, used to filter said background sound signal has a 3 dB cut-off frequency in the range of 1 kHz to 2 KHz.

* * * * *

专利名称(译)	冠状动脉疾病检测信号处理系统和方法		
公开(公告)号	US20190117165A1	公开(公告)日	2019-04-25
申请号	US16/166104	申请日	2018-10-21
[标]申请(专利权)人(译)	曾吉康 周军 拉布隆特DANIEL MARTIN SIMON 香鼠布雷迪		
申请(专利权)人(译)	周君 拉布隆特, DANIEL MARTIN, SIMON 香鼠, BRADY		
当前申请(专利权)人(译)	周君 拉布隆特, DANIEL MARTIN, SIMON 香鼠, BRADY		
[标]发明人	ZHOU JUN LABONTE DANIEL MARTIN SIMON LASKA BRADY		
发明人	ZENG, JIKANG ISLAM, MD SHAHIDUL ZHOU, JUN LABONTE, DANIEL MARTIN, SIMON LASKA, BRADY TELENKOV, SERGEY A.		
IPC分类号	A61B5/00 A61B7/04 A61B5/0402 H04R3/04 H03G3/30		
CPC分类号	A61B5/7203 A61B7/04 A61B5/7225 A61B5/0402 H04R3/04 H03G3/30 A61B5/6823 A61B2562/0204 H03F3/45 H03F2203/45151 H03F2203/45156 A61B5/721 A61B5/7257 A61B2562/0219 H04R1/46		
优先权	62/575364 2017-10-20 US		
外部链接	Espacenet USPTO		

摘要(译)

由记录模块获取的听诊声音信号通过截止频率在3到15Hz范围内的高通滤波器耦合, 随后用低通滤波器滤波, 并且可选地在下进行可变增益放大。外部控制 - 通过相关联的对接系统的USB或无线接口, 响应于所得到的处理的听诊声音信号。对接系统中的声音发生器产生相关的测试信号, 该测试信号对于多个频率中的每一个具有整数个波长。将测试信号应用于相应的听诊声音或振动传感器以测试其完整性。使用傅里叶变换分析由记录模块记录的所产生的声音信号以确定传感器完整性。

