



US 20180289327A1

(19) **United States**

(12) **Patent Application Publication**
Freeman et al.

(10) **Pub. No.: US 2018/0289327 A1**
(43) **Pub. Date: Oct. 11, 2018**

(54) **DELIVERY OF ELECTRODE GEL USING CPR PUCK**

A61N 1/04 (2006.01)
A61M 16/00 (2006.01)
A61H 31/00 (2006.01)

(71) Applicant: **ZOLL Medical Corporation**,
Chelmsford, MA (US)

(52) **U.S. Cl.**
CPC *A61B 5/6839* (2013.01); *A61B 5/04087*
(2013.01); *A61B 5/0452* (2013.01); *A61N*
1/046 (2013.01); *A61H 2031/002* (2013.01);
A61B 5/6833 (2013.01); *A61M 16/0048*
(2013.01); *A61N 1/0496* (2013.01); *A61B*
5/04085 (2013.01)

(72) Inventors: **Gary A. Freeman**, Waltham, MA (US);
Ulrich Herken, Medford, MA (US)

(21) Appl. No.: **16/005,173**

(22) Filed: **Jun. 11, 2018**

(57) **ABSTRACT**

Related U.S. Application Data

(63) Continuation of application No. 14/167,343, filed on
Jan. 29, 2014, now Pat. No. 9,999,393.

(60) Provisional application No. 61/758,063, filed on Jan.
29, 2013.

Publication Classification

(51) **Int. Cl.**
A61B 5/00 (2006.01)
A61B 5/0408 (2006.01)
A61B 5/0452 (2006.01)

An electrode assembly includes a first surface to be placed adjacent a person's skin and a second surface including a plurality of reservoirs of conductive gel. The plurality of reservoirs of conductive gel are disposed on sections of the electrode assembly that are at least partially physically separated and may move at least partially independently of one another to conform to contours of a body of a patient. The electrode assembly is configured to dispense an amount of the electrically conductive gel onto the first surface in response to an activation signal and to provide for a defibrillating shock to be applied to the patient through the amount of the electrically conductive gel.

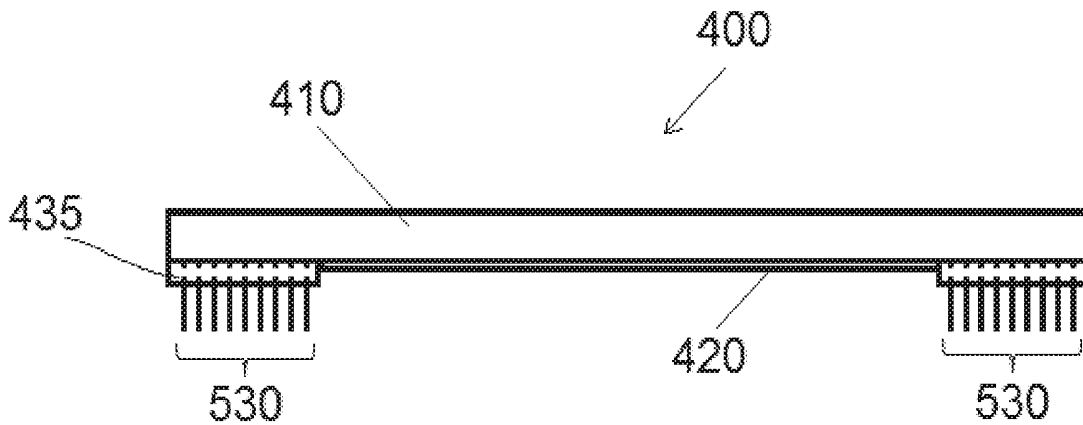

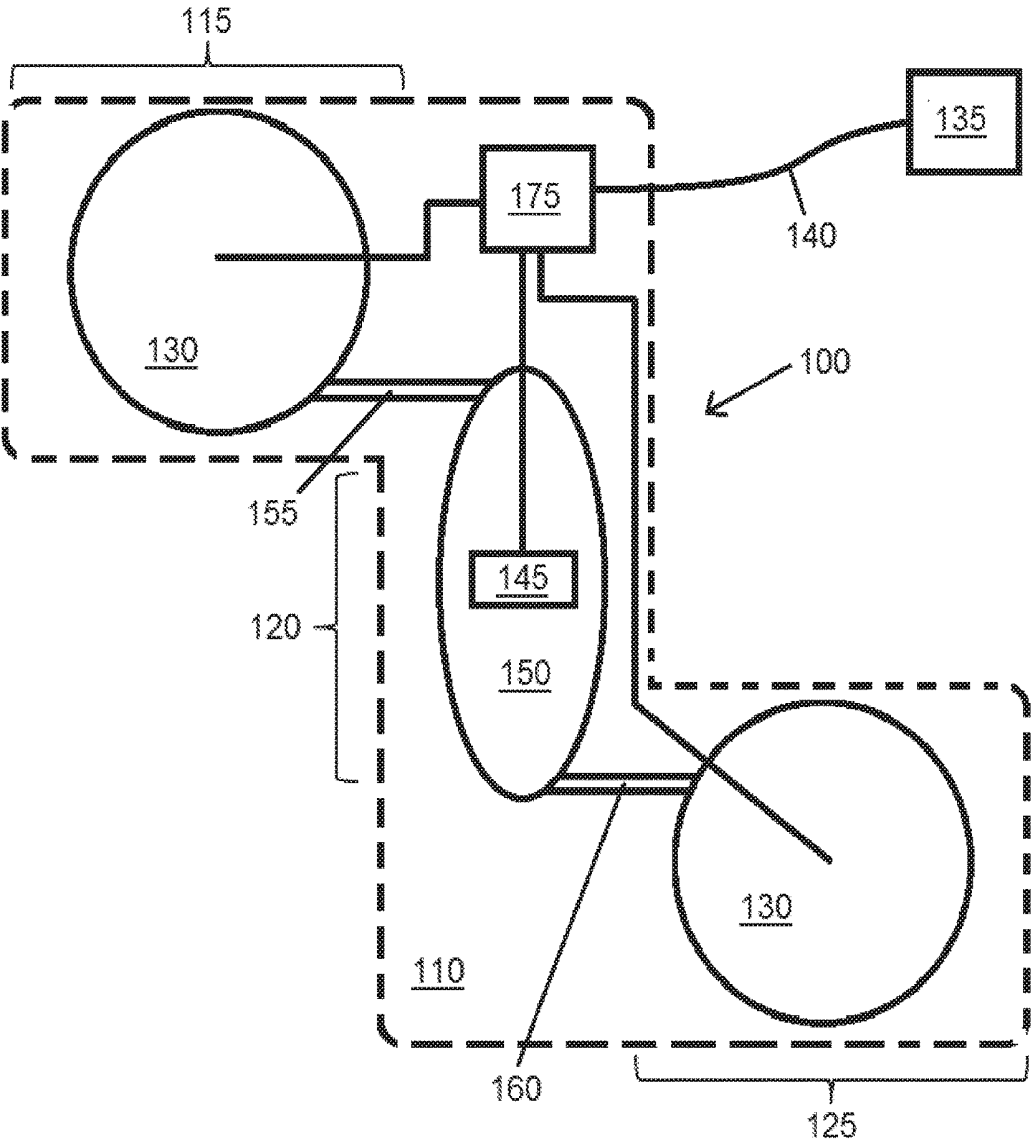

FIG. 1

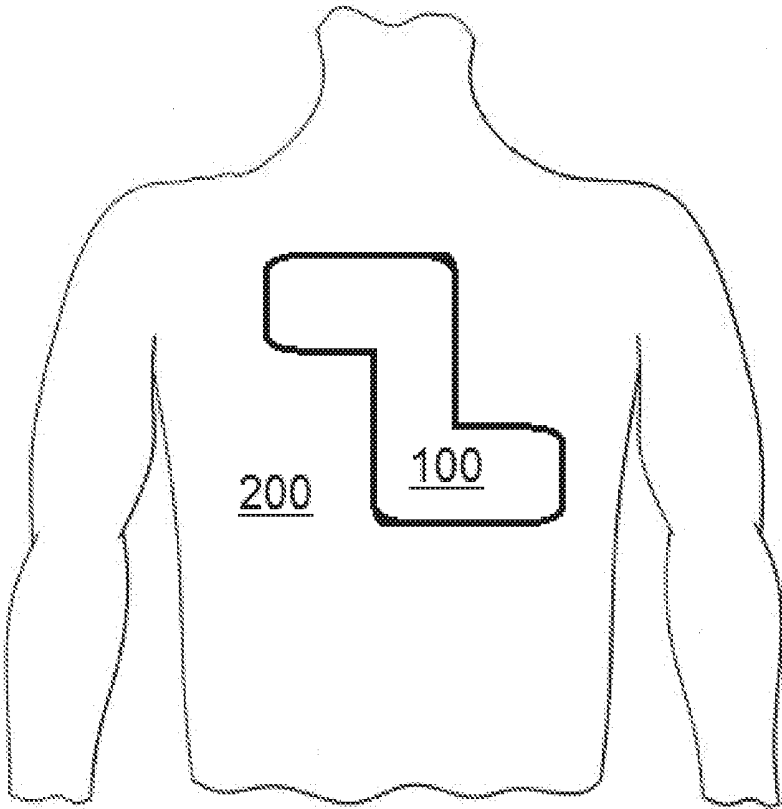

FIG. 2

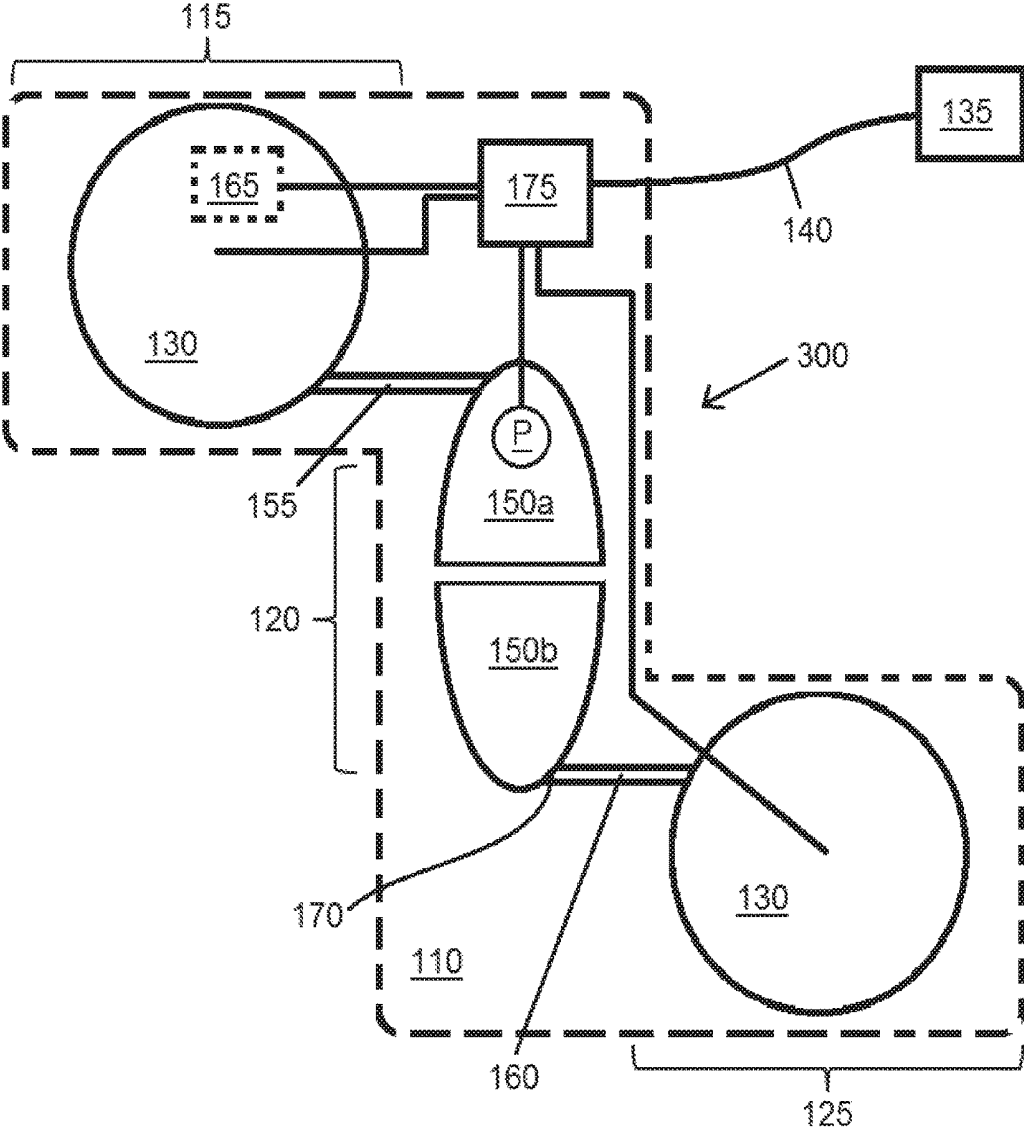

FIG. 3

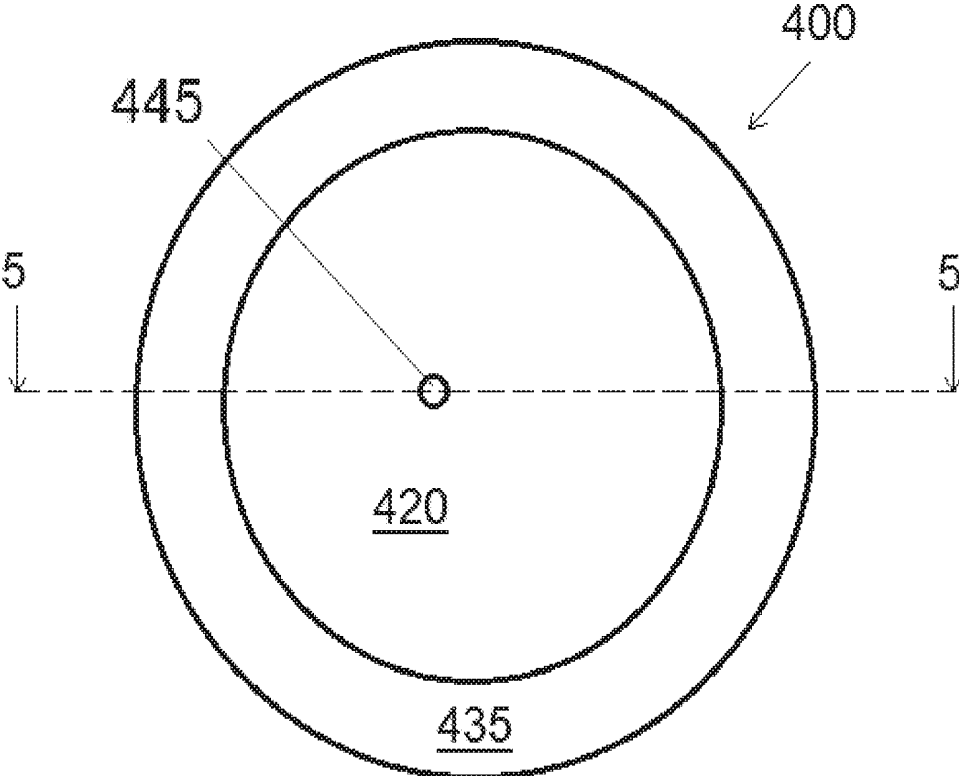

FIG. 4

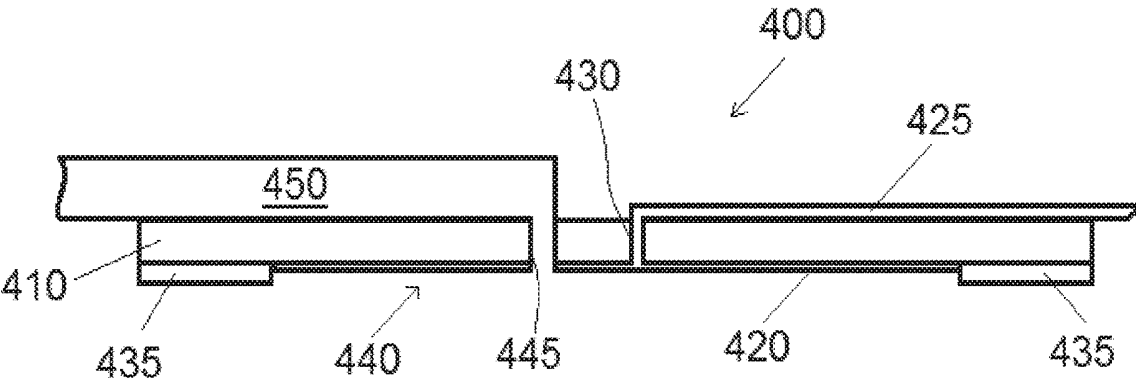

FIG. 5

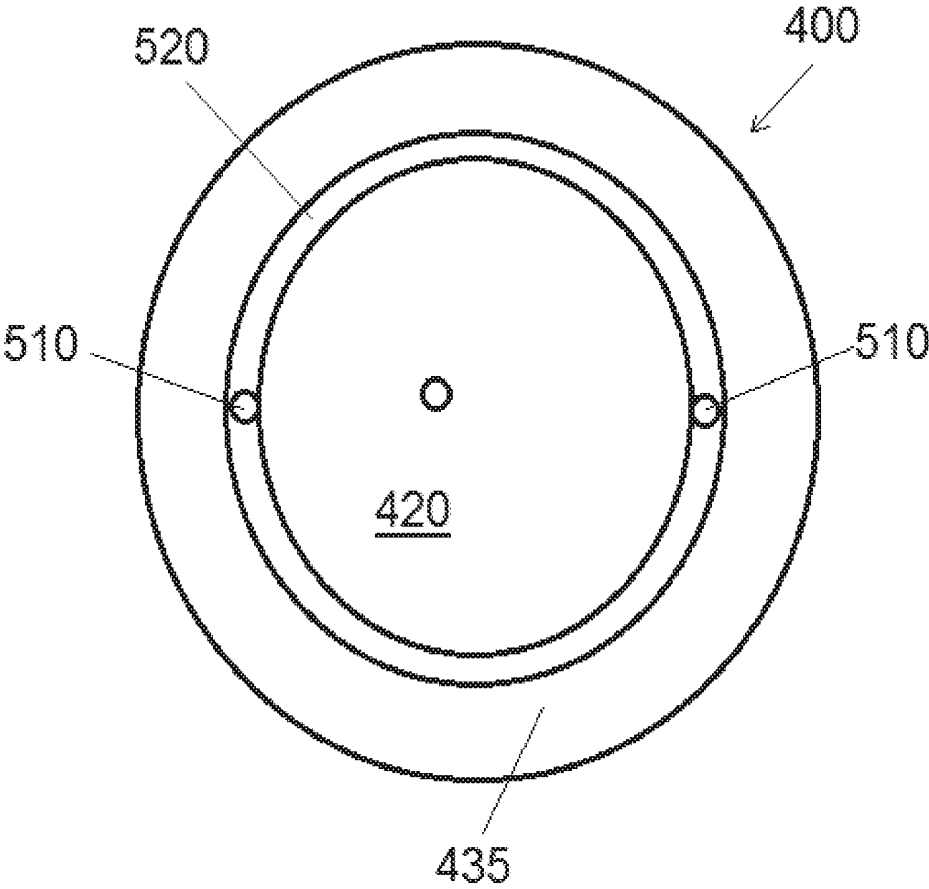

FIG. 6

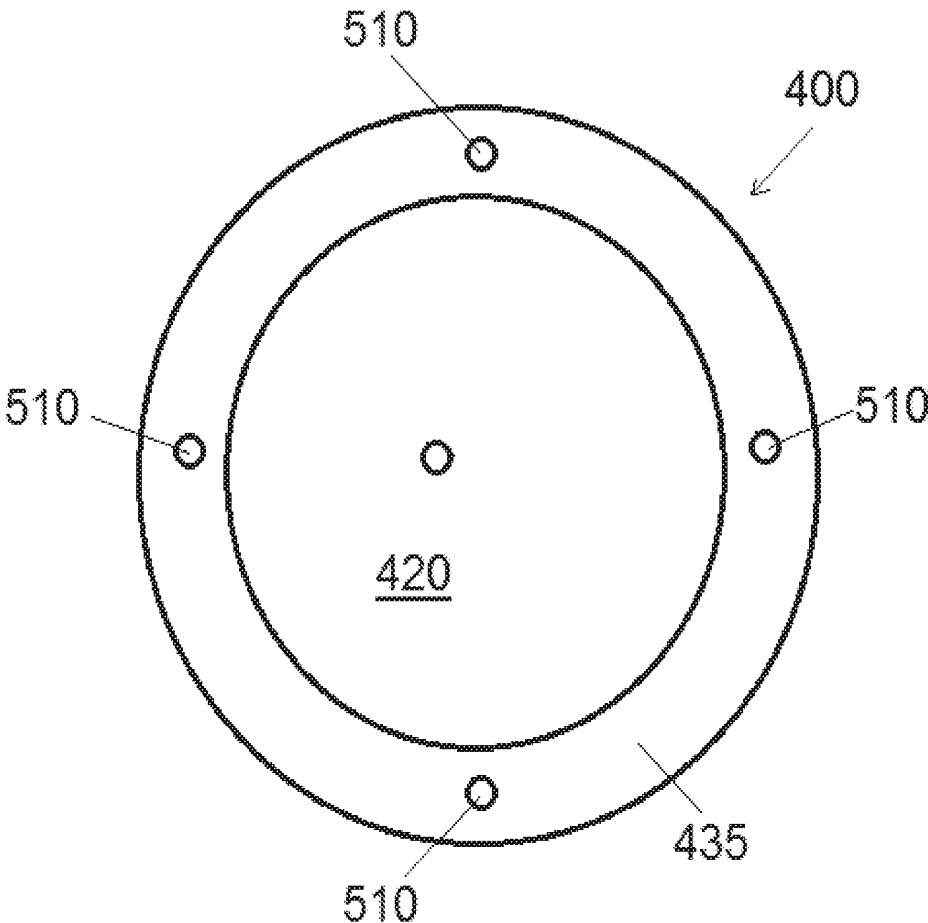

FIG. 7

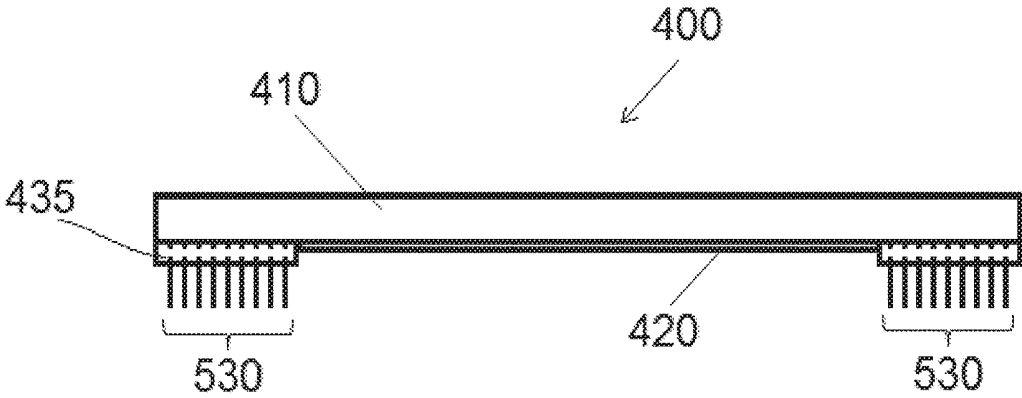

FIG. 8A

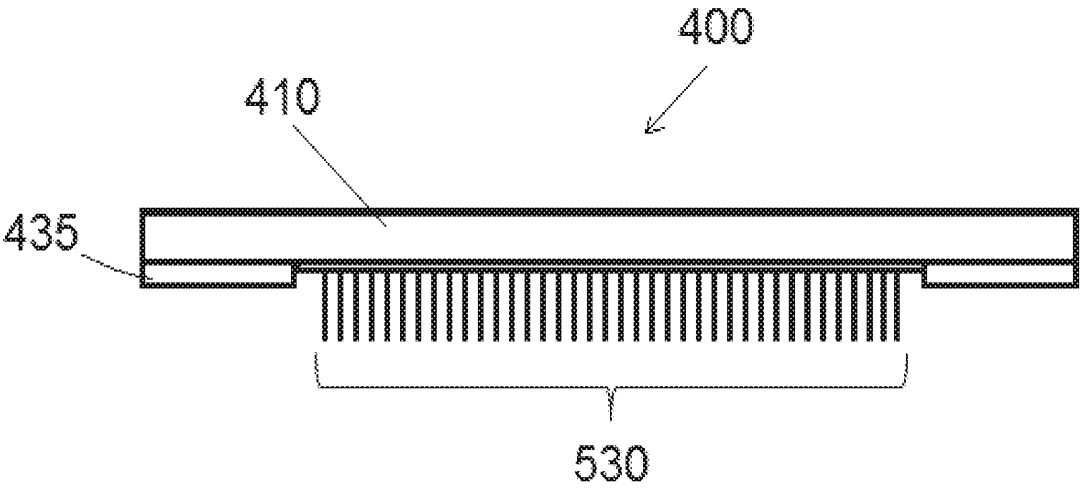

FIG. 8B

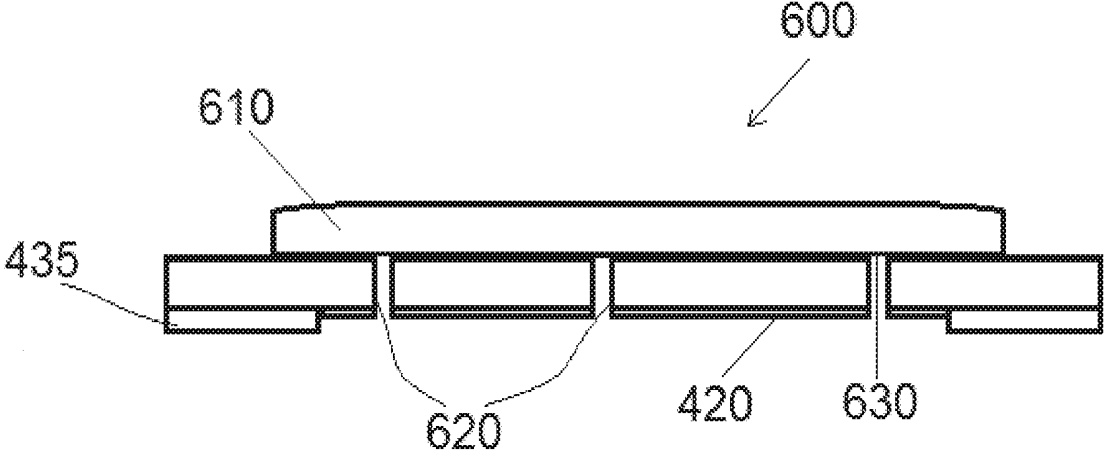

FIG. 9

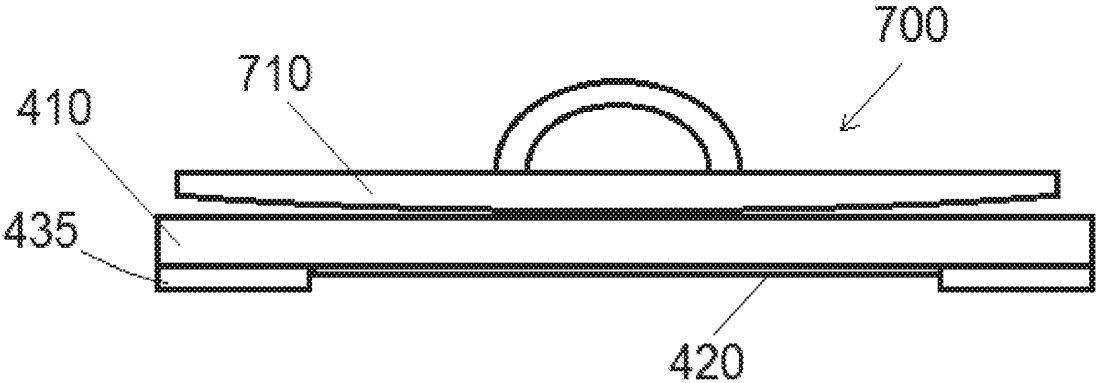

FIG. 10

DELIVERY OF ELECTRODE GEL USING CPR PUCK

RELATED APPLICATIONS

[0001] This application is a continuation of U.S. patent application Ser. No. 14/167,343, entitled "DELIVERY OF ELECTRODE GEL USING CPR PUCK" filed Jan. 29, 2014, which claims priority to U.S. Provisional Application Ser. No. 61/758,063, titled "DELIVERY OF ELECTRODE GEL USING CPR PUCK," filed on Jan. 29, 2013, which are each herein incorporated by reference in their entirety.

BACKGROUND

1. Field of the Invention

[0002] The present invention is directed to medical electrodes and electrode systems, and more particularly, to medical electrodes that may be used with a medical device, such as a defibrillator, which may be supplied with a conductive electrode gel prior to administration of an electrical charge to a subject through the medical electrodes.

2. Discussion of Related Art

[0003] Cardiac arrest and other cardiac health ailments are a major cause of death worldwide. Various resuscitation efforts aim to maintain the body's circulatory and respiratory systems during cardiac arrest in an attempt to save the life of the victim. The sooner these resuscitation efforts begin, the better the victim's chances of survival.

SUMMARY

[0004] In accordance with an aspect of the present invention, there is provided an electrode system. The electrode system comprises a compression device including a first gel reservoir. The first gel reservoir is configured to retain a conductive gel and to release the conductive gel responsive to compression of the compression device. The electrode system further comprises a first therapy pad configured to deliver a defibrillation pulse and a first conduit fluidly connecting the first gel reservoir to the first therapy pad.

[0005] In accordance with some embodiments, the system further comprises a second therapy pad.

[0006] In accordance with some embodiments, the system further comprises a second conduit fluidly connecting the first gel reservoir to the second therapy pad.

[0007] In accordance with some embodiments, the conductive gel is a first conductive gel and the compression device further includes a second gel reservoir in fluid communication with the second therapy pad. The second gel reservoir is configured to retain a second conductive gel and to release the second conductive gel responsive to compression of the compression device.

[0008] In accordance with some embodiments, the system further comprises a sensor configured to provide an indication of release of the conductive gel from the first gel reservoir.

[0009] In accordance with some embodiments, the sensor comprises a conductivity sensor disposed within the first therapy pad.

[0010] In accordance with some embodiments, the sensor comprises a pressure sensor disposed in the compression device.

[0011] In accordance with some embodiments, the pressure sensor is disposed within the first gel reservoir.

[0012] In accordance with some embodiments, the sensor comprises a valve disposed between the first gel reservoir and the first therapy pad.

[0013] In accordance with some embodiments, the sensor comprises a meter configured to measure an impedance between the first therapy pad and the second therapy pad.

[0014] In accordance with some embodiments, the first therapy pad includes a backing layer having a front surface configured to adhere to skin of a subject and a rear surface, a plate having a rear surface coupled to the front surface of the backing layer and a front surface that includes a conductive material layer, an electrical lead in electrical contact with the conductive material layer, and an adhesive film border formed on the front surface of the backing layer and defining a conductive gel cavity, the conductive gel cavity surrounded by the adhesive film border on all sides in a plane substantially parallel to the front surface of the backing layer, the conductive gel cavity in fluid communication with the first conduit.

[0015] In accordance with some embodiments, the backing layer is substantially impermeable to water and substantially permeable to air.

[0016] In accordance with some embodiments, the backing layer comprises expanded polytetrafluoroethylene.

[0017] In accordance with some embodiments, the adhesive film border comprises a light curable adhesive.

[0018] In accordance with some embodiments, the adhesive film border comprises an ultraviolet light curable adhesive.

[0019] In accordance with some embodiments, the system further comprises a source of ultraviolet light coupled to the first therapy pad.

[0020] In accordance with some embodiments, the source of ultraviolet light comprises a light emitting diode.

[0021] In accordance with some embodiments, the system further comprises a light guide configured and arranged to supply ultraviolet light to substantially all of the adhesive film border.

[0022] In accordance with some embodiments, one of the source of ultraviolet light and the light guide is at least partially disposed within the adhesive film border.

[0023] In accordance with some embodiments, the adhesive film border comprises epoxy.

[0024] In accordance with some embodiments, the first therapy pad includes a plurality of protrusions configured and arranged to facilitate adhesion of the first therapy pad to skin of a subject.

[0025] In accordance with some embodiments, the plurality of protrusions comprise barbs configured to penetrate an outer surface of the skin of the subject.

[0026] In accordance with some embodiments, the plurality of protrusions are configured to retain the first therapy pad in place on the skin of the subject.

[0027] In accordance with some embodiments, the barbs are biodegradable.

[0028] In accordance with some embodiments, the barbs are conductive.

[0029] In accordance with some embodiments, the plurality of protrusions comprise carbon nanofibers.

[0030] In accordance with some embodiments, the system further comprises a convex applicator for the first therapy pad.

[0031] In accordance with another aspect, there is provided a therapy electrode. The therapy electrode comprises a backing including a front surface and a rear surface, an electrolyte reservoir configured to release electrolyte onto the front surface of the backing responsive to application of a compressive force to the therapy electrode, and a plurality of barbs extending from the front surface of the backing and configured to penetrate an outer layer of skin of a subject and retain the therapy electrode in place on the skin of the subject.

[0032] In accordance with some embodiments, the barbs are biodegradable.

[0033] In accordance with some embodiments, the barbs are conductive.

[0034] In accordance with some embodiments, the barbs comprise carbon nanofibers.

BRIEF DESCRIPTION OF THE DRAWINGS

[0035] The accompanying drawings are not intended to be drawn to scale. In the drawings, each identical or nearly identical component that is illustrated in various figures is represented by a like numeral. For purposes of clarity, not every component may be labeled in every drawing. In the drawings:

[0036] FIG. 1 is a schematic illustration of an electrode system;

[0037] FIG. 2 illustrates the electrode system of FIG. 1 applied to the torso of a subject;

[0038] FIG. 3 is a schematic illustration of another electrode system;

[0039] FIG. 4 is a plan view of an electrode;

[0040] FIG. 5 is a cross sectional view of the electrode of FIG. 4;

[0041] FIG. 6 is a plan view of another electrode;

[0042] FIG. 7 is a plan view of another electrode;

[0043] FIG. 8A is a cross sectional view of another electrode;

[0044] FIG. 8B is a cross sectional view of another electrode;

[0045] FIG. 9 is a cross sectional view of another electrode; and

[0046] FIG. 10 is a cross sectional view of another electrode and an applicator for the electrode.

DETAILED DESCRIPTION

[0047] This invention is not limited in its application to the details of construction and the arrangement of components set forth in the following description or illustrated in the drawings. The invention is capable of other embodiments and of being practiced or of being carried out in various ways. Also, the phraseology and terminology used herein is for the purpose of description and should not be regarded as limiting. The use of “including,” “comprising,” “having,” “containing,” “involving,” and variations thereof herein is meant to encompass the items listed thereafter and equivalents thereof as well as additional items.

[0048] FIG. 1 is a schematic illustration of an electrode system, indicated generally at **100**, which may be utilized in, for example, an automated external defibrillator (AED) device, although embodiments of the electrode system may also or alternatively be used with other types of cardiac monitoring and/or treatment devices. Examples of AED devices include Advanced Life Support (ALS) AED devices,

such as the E Series, M Series, R Series, or X Series defibrillators, as well as Basic Life Support (BLS) AED devices, such as the AED Pro or AED Plus defibrillator, each available from ZOLL Medical Corporation of Chelmsford, Mass. The electrode system **100** may be placed on or secured to a torso of a subject **200**, as illustrated in FIG. 2, to provide treatment, for example, defibrillation.

[0049] As shown in FIG. 1, the electrode system **100** includes packaging **110**, which is indicated in FIG. 1 in dotted lines so as not to obscure the internal components of the electrode system **100**. The packaging **110** includes a substrate upon which other components of the electrode system are mounted. The packaging may be formed of a fabric, for example, cotton, or a plastic material. Embodiments of the present invention are not limited to any particular material of construction of the packaging **110**. The packaging **110** defines a first therapy pad **115**, a central region including a compression device **120**, and a second therapy pad **125**.

[0050] Each therapy pad **115**, **125**, includes an electrode **130**. The electrodes **130** are electrically coupled to a controller **135** which is in some embodiments located external to the electrode system **100**, for example, through an electrical connector **175** and electrical conductor(s) **140**. The controller is configured to deliver an electrical charge to the electrodes **130** as needed. The controller **135** may be supplied with power from an external source of power or by a battery, capacitor, battery and capacitor, or other electrical energy storage apparatus electrically coupled to the electrode system **100**.

[0051] The therapy pads and electrodes are illustrated in FIG. 1 as formed together in one integrated structure, however, in other embodiments, the therapy pads and/or electrodes may be provided in distinct packages on separate substrates. The distinct electrode/therapy pad packages may be coupled together by, for example, conduits for conductive electrode gel and/or electrical cables.

[0052] When placed on a subject to be treated by cardio pulmonary resuscitation (CPR), the central region of the packaging of the electrode system **100** provides a location at which a CPR administrator may apply compressions through the electrode system **100** to the chest of the subject. The central region of the packaging may include an accelerometer **145** which may monitor the frequency, depth, and intensity of compressions applied to the subject and supply this information to the controller **135**. The controller **135** may provide feedback, for example, through a speaker or display (not shown), to a CPR administrator based on the information supplied by the accelerometer regarding the sufficiency of the chest compressions or the need to increase or decrease the frequency, depth, or intensity of the compressions.

[0053] In accordance with one embodiment, the compression device **120** includes a gel reservoir **150**. The gel reservoir holds a conductive electrode gel. The conductive electrode gel is retained in the gel reservoir until needed. In some embodiments, responsive to compression of the compression device **120**, the gel reservoir releases the conductive electrode gel and supplies the conductive electrode gel to surfaces of the electrodes **130** through conduits **155**, **160** in fluid communication between the gel reservoir **150** and the electrodes **130**. In some embodiments, the conductive gel is retained within the gel reservoir by membranes at one or both ends of the conduits **155**, **160** which are configured

to rupture upon the application of sufficient pressure to the compression device. In other embodiments, the conductive gel is retained within the gel reservoir by mechanical valves at one or both ends of the conduits **155**, **160** which are configured to open upon the application of sufficient pressure to the compression device. Alternatively, the accelerometer **145** or a pressure sensor in the gel reservoir may supply a signal to the controller **135** responsive to compression of the compression device and the controller may provide a signal to open one or more mechanical valves in fluid communication between the gel reservoir **150** and the electrodes **130**. The mechanical valves may be located, for example, at one or both ends of the conduits **155**, **160**.

[0054] In an alternative embodiment, indicated generally at **300** in FIG. 3, the electrode system includes a pair of gel reservoirs **150a**, **150b**, each configured to supply conductive gel to a single electrode **130**. Other embodiments may include more than two gel reservoirs and/or more than two electrodes.

[0055] In some embodiments, the electrode system includes one or more sensors which provide an indication of release of the conductive electrode gel from the gel reservoir(s). For example, as illustrated in FIG. 3, the compression device **120** may include a pressure sensor **P** disposed within a gel reservoir. The pressure sensor may provide a signal to the controller indicative of a pressure applied to the compression device. The controller may compare a pressure calculated from the signal from the pressure sensor against a threshold pressure which is expected to cause release of conductive electrode gel from the gel reservoir. If the pressure calculated from the signal from the pressure sensor did not exceed the threshold, the controller would, for example, provide an indication of a fault, instruct a CPR administrator to apply greater pressure to the compression device, or send a signal to open a valve to allow the conductive electrode gel to flow from the gel reservoir(s) to the electrode(s). In another embodiment, the conductive electrode gel is retained within the gel reservoir under pressure. Release of the conductive electrode gel from the gel reservoir results in a reduced pressure within the gel reservoir. A signal supplied from the pressure sensor to the controller indicative of a pressure below a threshold pressure would indicate to the controller that the conductive electrode gel had been released from the gel reservoir.

[0056] In other embodiments, one or both therapy pads may include a conductivity sensor **165** disposed, for example, on a bottom surface of the electrode. The conductivity sensor **165** would indicate a lower conductivity in the presence of the conductive electrode gel than in the absence of the conductive electrode gel. The conductivity sensor **165** provides a conductivity signal to the controller **135** indicative of the presence or absence of the conductive electrode gel at the electrode. If the conductivity signal was indicative of the absence of the conductive electrode gel at the electrode, the controller would, for example, provide an indication of a fault, instruct a CPR administrator to apply greater pressure to the compression device, or send a signal to open a valve to allow the conductive electrode gel to flow from the gel reservoir(s) to the electrode(s). Alternatively still, in other embodiments, the controller may make an impedance measurement of the impedance between the electrodes (and including the subject) both before and after attempted deployment of the electrode gel to verify the presence and deployment of the electrode gel.

[0057] In another embodiment, a membrane or valve **170** disposed, for example, in one or both of the conduits **155**, **160** may provide a signal to the controller indicative of whether the membrane or valve **170** had been ruptured or opened to provide for the passage of the conductive gel. For example, the membrane or valve **170** may include a thin conductor which is severed upon opening of the membrane or valve **170**, providing a change in resistance which may be detected by the controller **135**. If the signal from the membrane or valve **170** was indicative of the conductive electrode gel not having been released, the controller would, for example, provide an indication of a fault, instruct a CPR administrator to apply greater pressure to the compression device, or send a signal to open a valve to allow the conductive electrode gel to flow from the gel reservoir(s) to the electrode(s).

[0058] In further embodiments, responsive to the detection of the application of CPR to a subject, for example, by signals provided from the accelerometer to the controller, the controller may cause the conductive electrode gel to flow to the electrodes **130** by the application of a pressurized gas to the inside of the gel reservoir(s), for example, as described in U.S. Pat. No. 5,078,134, titled PORTABLE DEVICE FOR SENSING CARDIAC FUNCTION AND AUTOMATICALLY DELIVERING ELECTRICAL THERAPY, issued Jan. 7, 1992, which is incorporated by reference herein in its entirety.

[0059] The controller **135** generally includes at least one processor, microprocessor, or controller, such as a processor commercially available from companies such as Texas Instruments, Intel, AMD, Sun, IBM, Motorola, Freescale and ARM Holdings. In some embodiments, the at least one processor of the controller **135** is configured to monitor the patient's medical condition, to perform medical data logging and storage, and/or to provide medical treatment to the patient in response to a detected medical condition, such as cardiac arrhythmia. Although not shown, the electrode system may include additional sensors capable of monitoring the physiological condition or activity of the patient. For example, sensors capable of measuring blood pressure, heart rate, thoracic impedance, pulse oxygen level, respiration rate, heart sounds, and the activity level of the patient may also be provided.

[0060] It is to be understood that the electrode systems and electrodes described herein are not limited to the shapes, sizes, or configurations illustrated. For example, although illustrated as disks, the electrodes **130** may alternatively be in the shape of rectangles or other shapes. Electrode systems may include more than a single electrode in a therapy pad and may include more than one therapy pad. Gel reservoirs as described herein may supply conductive electrode gel to more than one electrode and electrodes may be supplied conductive electrode gel from more than one gel reservoir.

[0061] An embodiment of an electrode **400** which may be used with electrode systems as described herein or with other electrode systems is illustrated in plan view from a front side (i.e., the side of the electrode to be adjacent the skin of the subject) in FIG. 4 and in cross section through line 5-5 of FIG. 4 in FIG. 5. The electrode includes a backing layer **410** (FIG. 5) which may be formed of a flexible, waterproof, yet breathable material that permits the passage of water vapor away from the subject. Suitable materials may include, for example, polyurethane or Tegaderm™ wound care dressings (3M, St. Paul, Minn., USA), expanded

polytetrafluoroethylene, for example, Gore-Tex® (W. L. Gore & Associates, Inc., Elkton, Md., USA), or other non-woven polymers. The backing layer 410 includes a front surface configured to adhere to the skin of a subject and a rear surface. A plate 420 includes a rear surface coupled to the front surface of the backing layer and a front surface that includes a conductive material layer. The conductive material layer may include, for example, a silver/silver chloride alloy. The plate 420 is, in some embodiments, formed from a conductive material, for example, a metal or conductive polymer. An electrical lead 425 is provided in electrical contact with the conductive material layer of the plate, for example, by passing through an aperture 430 through the backing layer 410. The electrical lead extends to a controller configured to deliver charge to the electrode and/or monitor a signal from the electrode. The electrical lead 425 is illustrated as extending across the rear of the electrode backing layer, but in other embodiments may extend across the front or may be embedded in the electrode backing layer.

[0062] The electrode 400 further includes an adhesive film layer 435 coupled to the front side of the electrode. The adhesive film layer forms a closed geometric shape, for example, a ring. The adhesive film layer, in combination with the plate 420, defines a conductive gel cavity 440. The conductive gel cavity 440 is surrounded on all sides by the adhesive film layer in a plane substantially parallel to the front surface of the backing layer. A gel conduit 450, which in some embodiments may be similar to one of conduits 155, 160, is fluidly connected to a source of conductive electrode gel, for example gel reservoir 150 of FIG. 1. The gel conduit 450 is also in fluid communication with the conductive gel cavity 440 through an aperture 445 in the electrode. In use, a conductive electrode gel would flow through the gel conduit 450 and into the conductive gel cavity 440 through the aperture 445 to provide a low resistance electrical path between the conductive material layer of the plate 420 and the skin of a subject to which the electrode 400 is attached to facilitate, for example, providing defibrillation to the subject with the electrode.

[0063] The adhesive film layer 435 facilitates retaining the electrode in contact with the skin of a subject and also confines conductive electrode gel within the conductive gel cavity 440. The adhesive film layer may include any form of adhesive that is capable of securing the electrode to the skin of a subject. For example, the adhesive film layer 435 includes, in some embodiments, a light curable adhesive. In some embodiments, the adhesive film layer 435 includes an ultraviolet (UV) light curable adhesive. In some embodiments, the electrode may be placed on the skin of a subject and exposed to ultraviolet light or light of a different frequency to cure the adhesive. In some embodiments, a source of light for curing the adhesive, for example a source of ultraviolet light, is included in an electrode system housing the electrode, or in the electrode itself. As illustrated in FIG. 6, the electrode may include one or more light emitting diodes (LEDs) 510, for example, UV LEDs positioned proximate the light curable adhesive of the adhesive film layer 435. The one or more LEDs 510 are, in some embodiments, optically coupled to a light pipe or guide 520. The light pipe or guide 520 directs light from the LED(s) to portions of the adhesive film layer 435 which might not otherwise be exposed to sufficient light from the LED(s) to cure. The light pipe or guide 520 facilitates the curing of the light curable adhesive of the adhesive film layer 435 with the

light provided by the one or more LEDs 510. In some embodiments, as illustrated in FIG. 7, the LEDs 510 and/or light pipe or guide 520 (not illustrated in FIG. 7) are embedded in the adhesive film layer 435 rather than positioned proximate an edge of the adhesive film layer 435 as in FIG. 6.

[0064] In use, the one or more LEDs 510 are activated to cure the light curable adhesive after the electrode has been positioned in place on the skin of a subject. The one or more LEDs 510 are in one embodiment activated by the controller 135, and in other embodiments activated by a separate switch and/or independent power supply. In some embodiments the electrode 400 includes a pressure sensor or switch which activates the one or more LEDs 510 upon application of more than a threshold pressure to the electrode against the skin of a subject.

[0065] The adhesive film layer 145 may alternatively or additionally include one or more forms of adhesive other than a light curable adhesive. For example, the adhesive film layer 145 includes, in some embodiments, epoxy.

[0066] Embodiments of the electrode may include one or more additional features which facilitate retaining the electrode in place on the skin of a subject. For example, as illustrated in FIG. 8A, where features such as the electrical lead 425 and gel conduit 450 have been omitted for clarity, the electrode 400 may include a plurality of protrusions 530. The protrusions 530 may extend through the adhesive film layer 435. Additionally or alternatively, the protrusions may be present on another portion of the electrode, for example, on a portion of the backing 410 extending beyond the external border of the adhesive material layer and/or in an inner region of the electrode as illustrated in FIG. 8B. The protrusions 530 may additionally or alternatively be present on a surface of a therapy pad including the electrode and positioned proximate the electrode to facilitate retaining the electrode in place on the skin of the subject.

[0067] The protrusions 530 are, in some embodiments, barbs configured to penetrate an outer surface of the skin of a subject. In some embodiments the barbs are formed of a biodegradable material which breaks down when inserted into the skin of a subject after a period of, for example, about one day. In some embodiments, the barbs comprise a conductive material, for example, metal wires or carbon nanotubes or nanofibers, and in some embodiments are configured to conduct an electrical charge into the subject during, for example, defibrillation of the subject.

[0068] In a further embodiment, illustrated generally at 600 in FIG. 9, an electrode may include an integral electrode gel reservoir 610 rather than being in fluid communication with a separate gel reservoir. The integral electrode gel reservoir 610 may be formed on the rear surface of the backing layer and may deliver conductive electrode gel into the conductive gel cavity 440 through an aperture or apertures 620. The aperture or apertures 620 in some embodiments are covered by a thin membrane 630, for example, a polymer film that ruptures upon application of pressure to the electrode gel reservoir to allow the passage of conductive electrode gel.

[0069] In a further embodiment, illustrated generally at 700 in FIG. 10, the electrode system may include an applicator 710 for aiding attachment of the electrode(s) to the skin of a subject. The applicator 710 may be removably coupled to the electrode with magnets, hook and loop fasteners, snaps, tabs and slots, or any other form of con-

necter known in the art. Alternatively, the applicator may simply be provided as part of the electrode system and used to adhere each electrode to the body of the subject. The applicator 710 includes a convex surface on a side of the applicator configured to contact the rear surface of the electrode. When a user applies the electrode to the skin of a subject using the applicator, the applicator first directs pressure to a central region of the electrode. Application of additional pressure to the applicator causes the direction of force applied to the electrode to move radially outward from the center of the electrode. The application of force first to the center of the electrode and then to portions of the electrode radially offset from the center also facilitates the removal of air from between the electrode and the skin of a subject to which the electrode is applied and helps ensure the electrode conforms to the skin of the subject as closely as possible. The applicator may be removed from the electrode once the electrode is attached to the skin of a subject and the conductive electrode gel suitably distributed.

[0070] Having thus described several aspects of at least one embodiment of this invention, it is to be appreciated various alterations, modifications, and improvements will readily occur to those skilled in the art. For example, it is to be appreciated that any of the features of any of the embodiments disclosed herein may be combined or substituted for features of any other embodiment disclosed herein. Such alterations, modifications, and improvements are intended to be part of this disclosure, and are intended to be within the scope of the invention. Accordingly, the foregoing description and drawings are by way of example only.

What is claimed is:

1. An electrode system comprising:
 - a first therapy pad having a front surface configured to be placed in contact with skin of a patient and a back surface, the first therapy pad configured to deliver a defibrillation pulse;
 - a first gel reservoir fluidly connected to the first therapy pad and configured to retain a conductive gel and to release the conductive gel responsive to compressive force applied to the first gel reservoir; and
 - a plurality of protrusions extending from the front surface of the first therapy pad and configured to conduct an electrical charge into the patient during delivery of the defibrillation pulse,
 wherein delivery of chest compressions to the patient by a CPR administrator causes the first gel reservoir to release the conductive gel therefrom to the front surface of the first therapy pad.
2. The system of claim 1, wherein the plurality of protrusions are configured to retain the first therapy pad in place on the skin of the patient.
3. The system of claim 1, where the plurality of protrusions comprise barbs configured to penetrate an outer surface of the skin of the patient.
4. The system of claim 3, wherein the barbs are biodegradable.
5. The system of claim 3, wherein the barbs are conductive.
6. The system of claim 1, wherein the plurality of protrusions comprise carbon nanofibers.
7. The system of claim 1, wherein the first therapy pad includes:

- a backing layer having a front surface configured to adhere to skin of the patient and a rear surface forming the back surface of the first therapy pad;
- a plate having a rear surface coupled to the front surface of the backing layer and a front surface that includes a conductive material layer;
- an electrical lead in electrical contact with the conductive material layer; and
- an adhesive film border formed on the front surface of the backing layer and defining a conductive gel cavity, the conductive gel cavity surrounded by the adhesive film border on all sides in a plane substantially parallel to the front surface of the backing layer, the conductive gel cavity in fluid communication with the first gel reservoir.

8. The system of claim 7, wherein the plurality of protrusions extend through the adhesive film border.

9. The system of claim 7, wherein the plurality of protrusions are provided on a portion of the front surface of the backing layer beyond the adhesive film border.

10. The system of claim 7, wherein the plurality of protrusions are provided on the front surface of the plate.

11. The system of claim 1, further comprising: a chest compression sensor associated with the first gel reservoir and separate from the first therapy pad, the chest compression sensor configured to be placed on a chest of the patient and to be compressed during delivery of chest compressions to the patient by the CPR administrator.

12. The system of claim 11, wherein the delivery of the chest compressions to the patient by the CPR administrator at the chest compression sensor compresses the first gel reservoir.

13. The system of claim 11, wherein the chest compression sensor comprises an accelerometer configured to sense information representative of the chest compressions applied to the patient.

14. The system of claim 1, further comprising a sensor configured to provide an indication of release of the conductive gel from the first gel reservoir.

15. The system of claim 14, wherein the sensor comprises a conductivity sensor disposed within the first therapy pad.

16. The system of claim 14, wherein the sensor comprises a pressure sensor disposed in the first gel reservoir.

17. The system of claim 14, wherein the sensor comprises a valve disposed between the first gel reservoir and the first therapy pad.

18. The system of claim 1, further comprising a first conduit extending from the first gel reservoir and being configured for fluidly connecting the first gel reservoir to the first therapy pad.

19. The system of claim 18, wherein the first conduit extends from the first gel reservoir in a first direction which is substantially orthogonal to a direction of the compression of the first gel reservoir.

20. The system of claim 19, further comprising a second therapy pad.

21. The system of claim 20, further comprising a second conduit fluidly connecting the first gel reservoir to the second therapy pad, the second conduit extending from the first gel reservoir in a second direction which is substantially orthogonal to the direction of the compression of the first gel reservoir, the first direction being different from the second direction.

22. The system of claim **20**, wherein the conductive gel is a first conductive gel and wherein the system further includes a second gel reservoir in fluid communication with the second therapy pad, the second gel reservoir configured to retain a second conductive gel and to release the second conductive gel responsive to compression of the second gel reservoir.

23. A therapy electrode configured to deliver a defibrillation pulse, comprising:

a backing layer including a front surface and a rear surface;

a gel reservoir configured to release conductive gel onto the front surface of the backing responsive to application of a compressive force to the gel reservoir; and

a plurality of protrusions extending from the front surface of the backing and configured to penetrate an outer layer of skin of a patient and conduct an electrical charge into the patient during delivery of a defibrillation pulse,

wherein delivery of chest compressions to the patient by a CPR administrator provides the compressive force for the conductive gel to be released from the gel reservoir.

24. The therapy electrode of claim **23**, wherein the plurality of protrusions are configured to retain the therapy electrode in place on the skin of the patient.

25. The therapy electrode of claim **23**, where the plurality of protrusions comprise barbs.

26. The therapy electrode of claim **25**, wherein the barbs are biodegradable.

27. The therapy electrode of claim **25**, wherein the barbs are conductive.

28. The therapy electrode of claim **23**, wherein the plurality of protrusions comprise carbon nanofibers.

29. The therapy electrode of claim **23**, further comprising: a plate having a rear surface coupled to the front surface of the backing layer and a front surface that includes a conductive material layer;

an electrical lead in electrical contact with the conductive material layer; and

an adhesive film border formed on the front surface of the backing layer and defining a conductive gel cavity, the conductive gel cavity surrounded by the adhesive film border on all sides in a plane substantially parallel to the front surface of the backing layer, the conductive gel cavity in fluid communication with the gel reservoir.

30. The therapy electrode of claim **29**, wherein the plurality of protrusions extend through the adhesive film border.

31. The therapy electrode of claim **29**, wherein the plurality of protrusions are provided on a portion of the front surface of the backing layer beyond the adhesive film border.

32. The therapy electrode of claim **29**, wherein the plurality of protrusions are provided on the front surface of the plate.

* * * * *

专利名称(译)	使用CPR圆盘递送电极凝胶		
公开(公告)号	US20180289327A1	公开(公告)日	2018-10-11
申请号	US16/005173	申请日	2018-06-11
[标]申请(专利权)人(译)	卓尔医学产品公司		
申请(专利权)人(译)	ZOLL医疗公司		
当前申请(专利权)人(译)	ZOLL医疗公司		
[标]发明人	FREEMAN GARY A HERKEN ULRICH		
发明人	FREEMAN, GARY A. HERKEN, ULRICH		
IPC分类号	A61B5/00 A61B5/0408 A61B5/0452 A61N1/04 A61H31/00 A61M16/00		
CPC分类号	A61B5/0452 A61B5/04087 A61B5/04085 A61B5/6833 A61M16/0048 A61N1/0496 A61B5/6839 A61H2031/002 A61N1/046		
优先权	61/758063 2013-01-29 US		
外部链接	Espacenet USPTO		

摘要(译)

电极组件包括邻近人的皮肤放置的第一表面和包括多个导电凝胶储存器的第二表面。多个导电凝胶储存器设置在电极组件的至少部分物理分离的部分上，并且可以至少部分地彼此独立地移动以符合患者身体的轮廓。电极组件被配置成响应于激活信号将一定量的导电凝胶分配到第一表面上，并且通过导电凝胶的量向患者施加除颤电击。

