



US 20180117341A1

(19) **United States**

(12) **Patent Application Publication**
Kane et al.

(10) **Pub. No.: US 2018/0117341 A1**
(43) **Pub. Date: May 3, 2018**

(54) **IMPLANTABLE MEDICAL DEVICE WITH PRESSURE SENSOR**

(52) **U.S. Cl.**
CPC *A61N 1/3706* (2013.01); *A61N 1/36521* (2013.01); *A61B 5/0031* (2013.01); *A61N 1/37512* (2017.08)

(71) Applicant: **CARDIAC PACEMAKERS, INC.**, St. Paul, MN (US)

(72) Inventors: **Michael J. Kane**, St. Paul, MN (US); **Benjamin J. Haasl**, Forest Lake, MN (US); **Keith R. Maile**, New Brighton, MN (US)

(57) **ABSTRACT**

(73) Assignee: **CARDIAC PACEMAKERS, INC.**, St. Paul, MN (US)

An implantable medical device (IMD) is configured with a pressure sensor. The IMD includes a housing, a pressure sensor and a fluid filled cavity. The housing has a diaphragm that is exposed to the environment outside of the housing. The pressure sensor has a pressure sensor diaphragm that is responsive to a pressure applied to the pressure sensor diaphragm and provides a pressure sensor output signal that is representative of the pressure applied to the pressure sensor diaphragm. The fluid filled cavity is in fluid communication with both the diaphragm of the housing and the pressure sensor diaphragm of the pressure sensor. The fluid filled cavity is configured to communicate a measure related to the pressure applied by the environment to the diaphragm of the housing to the pressure sensor diaphragm of the pressure sensor.

(21) Appl. No.: **15/791,311**

(22) Filed: **Oct. 23, 2017**

Related U.S. Application Data

(60) Provisional application No. 62/413,766, filed on Oct. 27, 2016.

Publication Classification

(51) **Int. Cl.**
A61N 1/37 (2006.01)
A61N 1/375 (2006.01)
A61B 5/00 (2006.01)

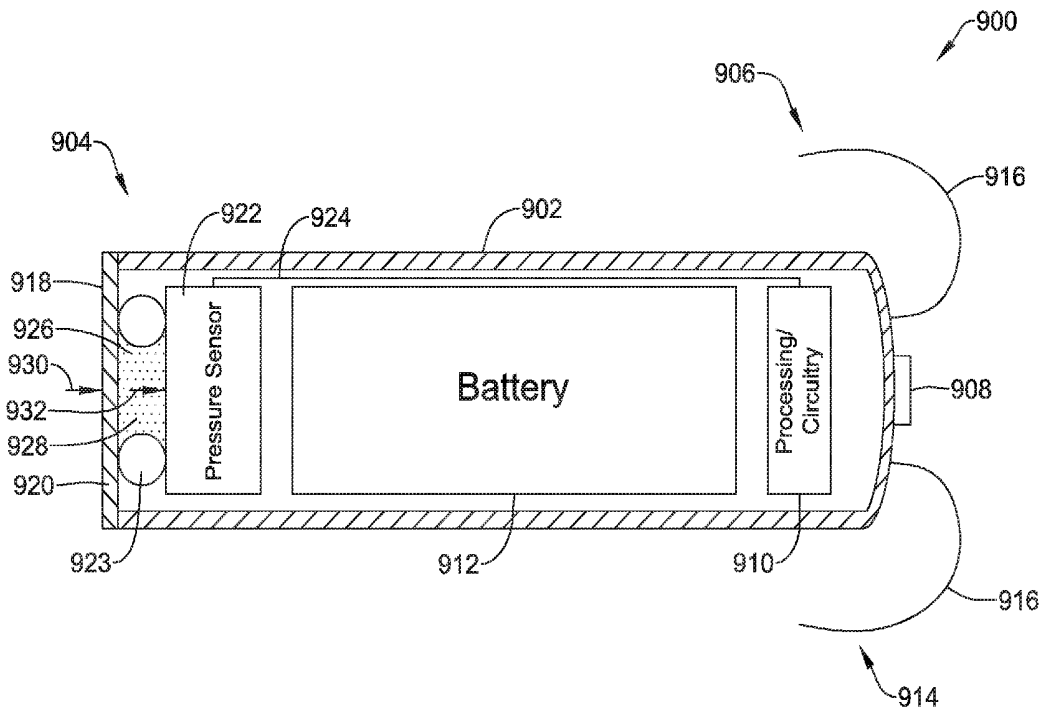

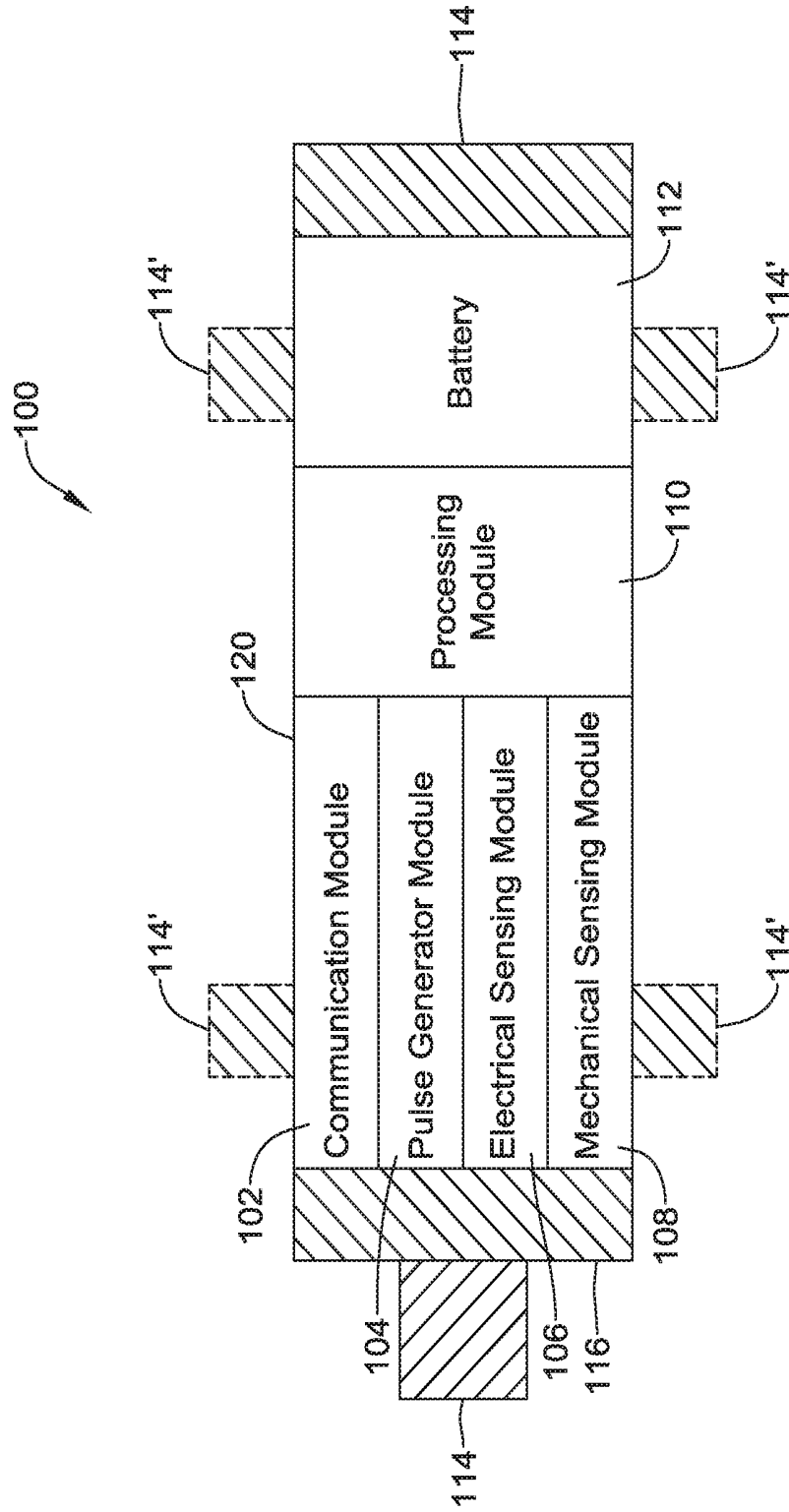

FIG. 1

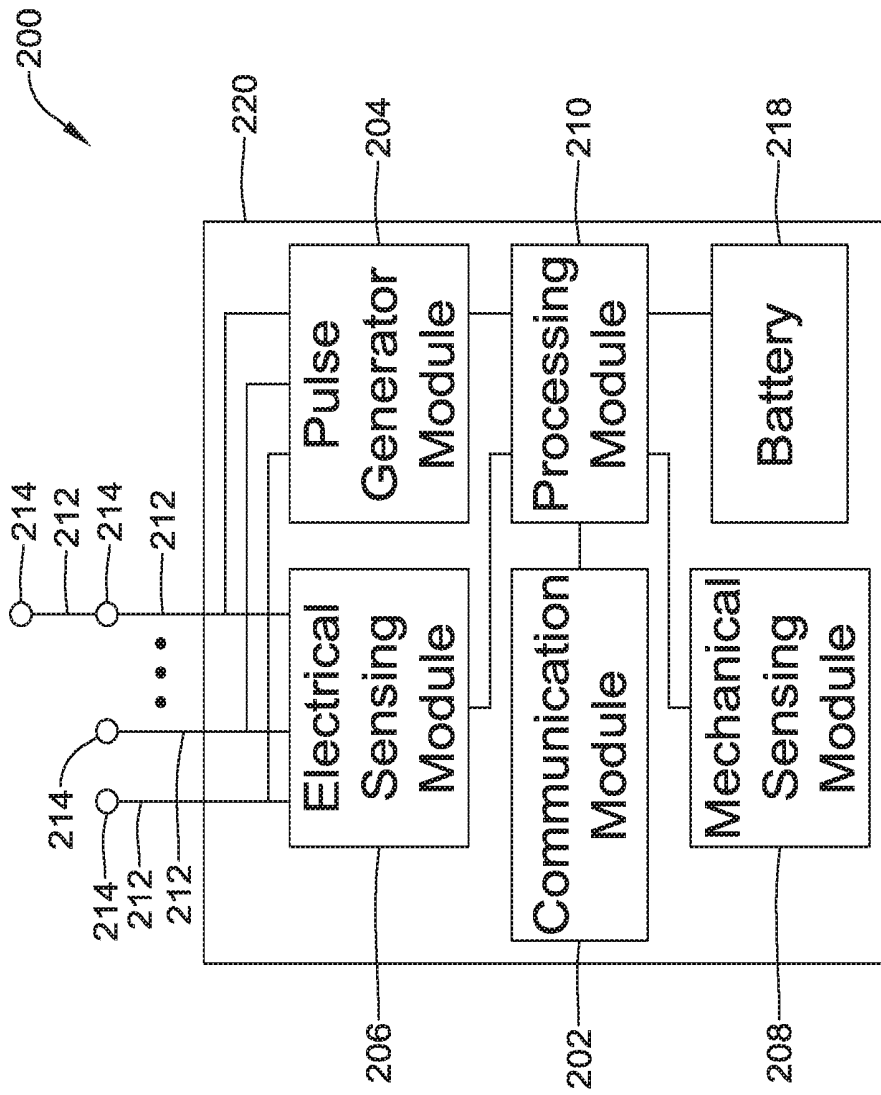

FIG. 2

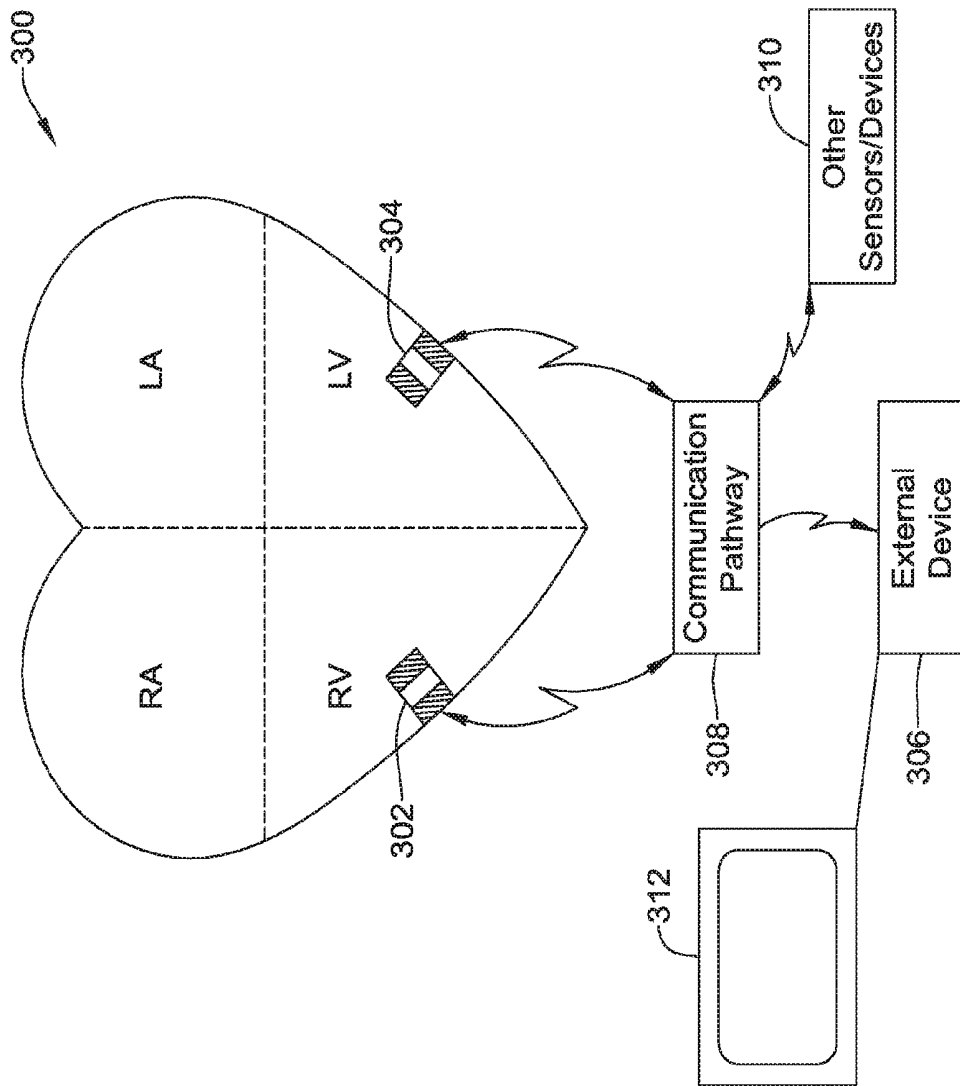

FIG. 3

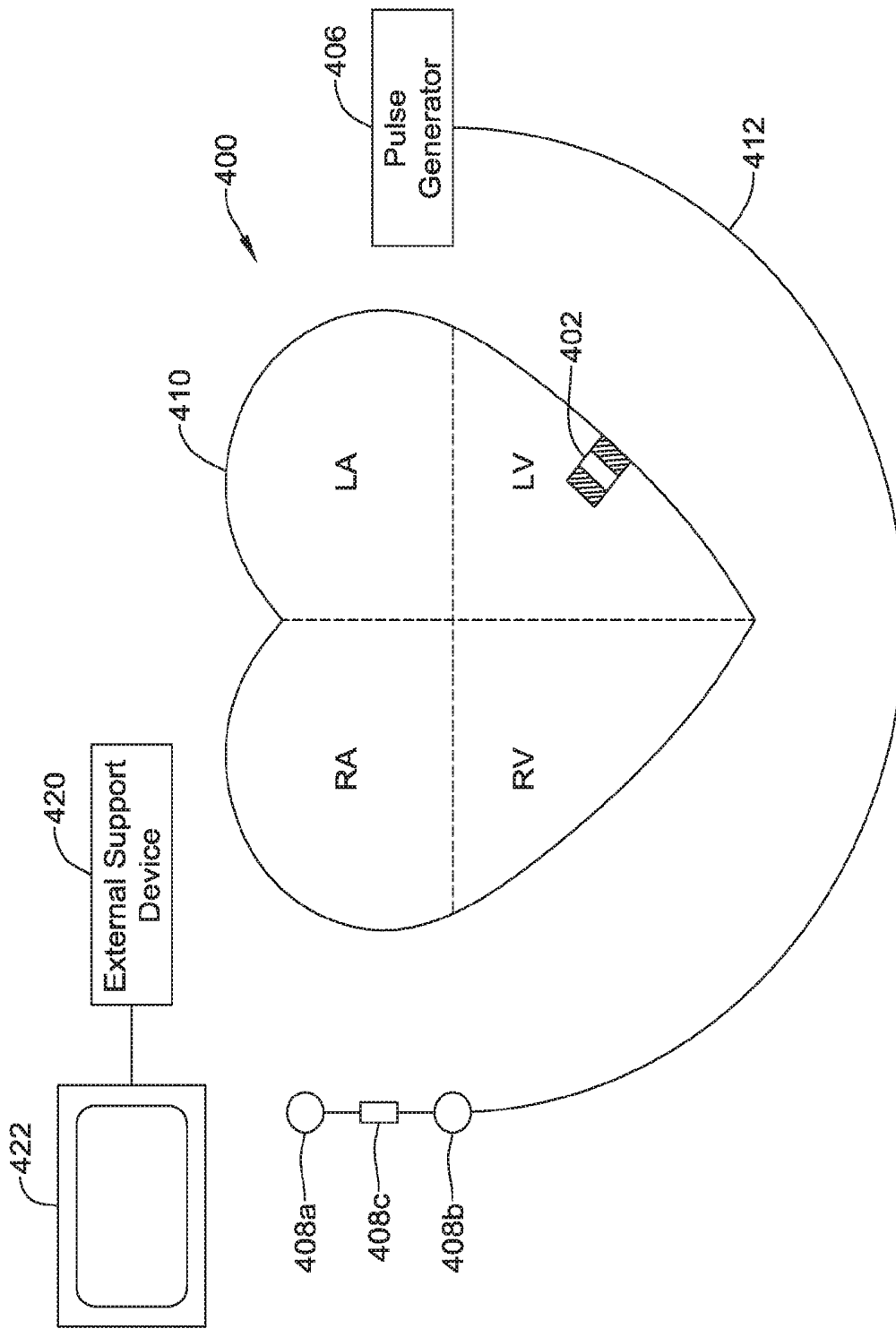

FIG. 4

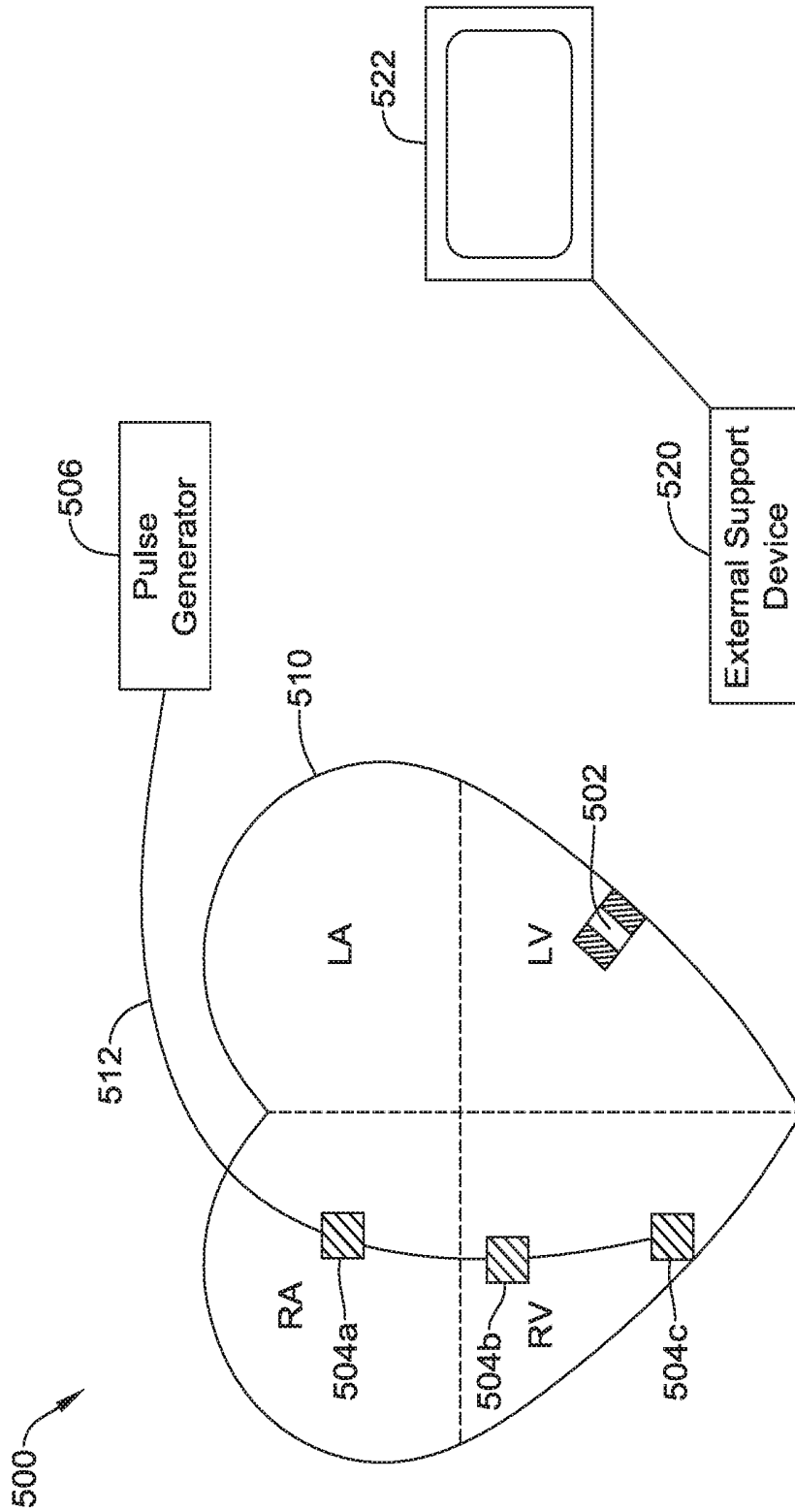

FIG. 5

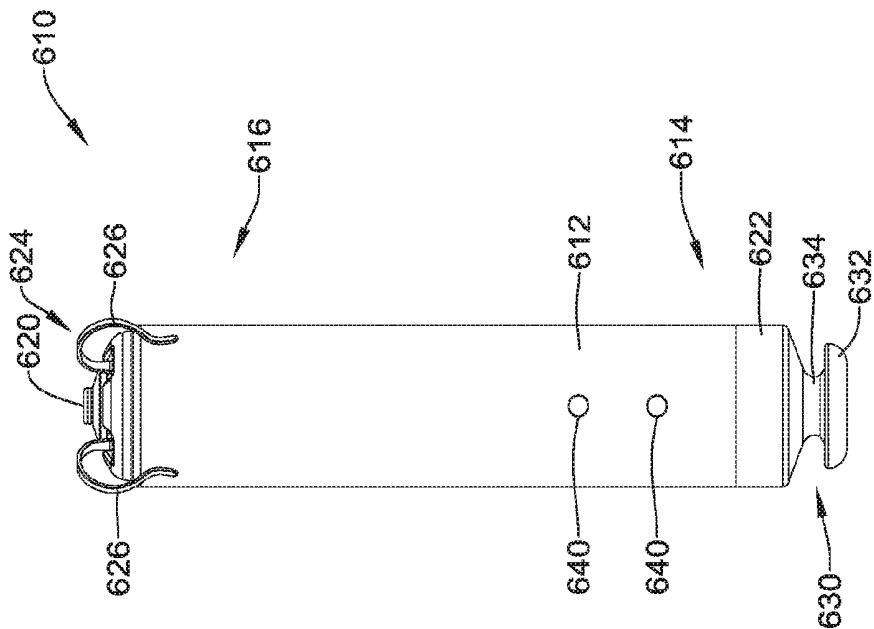

FIG. 6

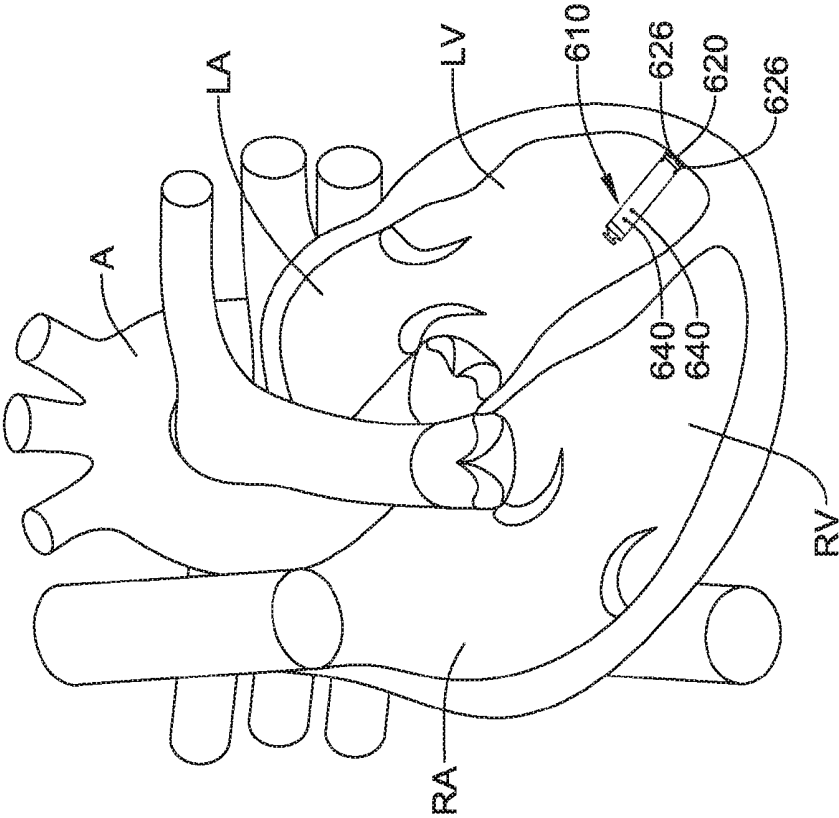

FIG. 7A

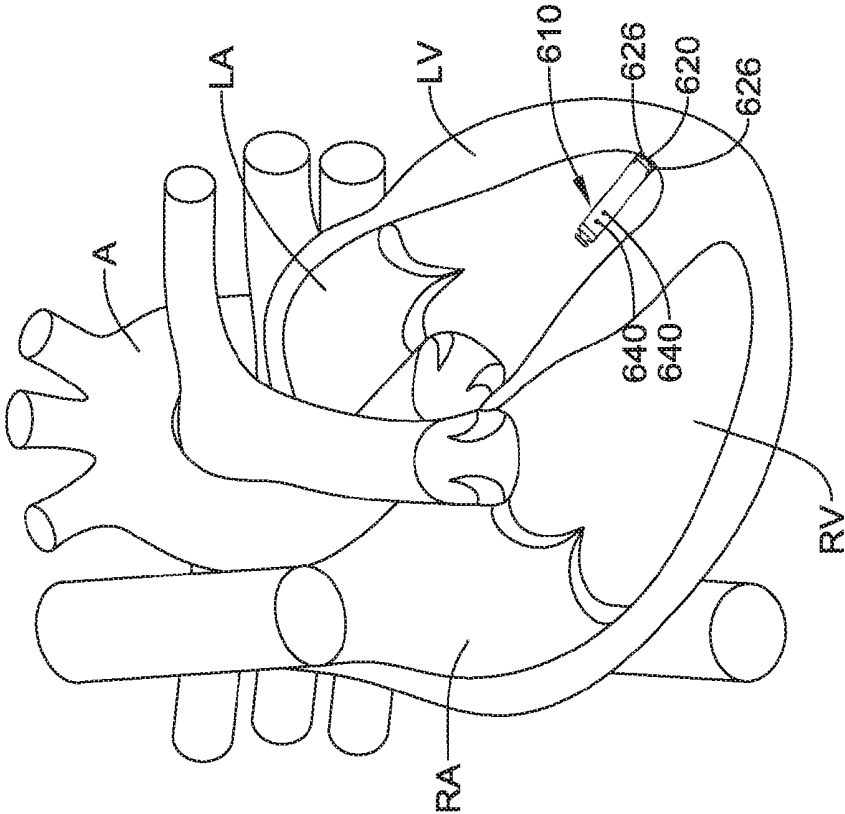

FIG. 7B

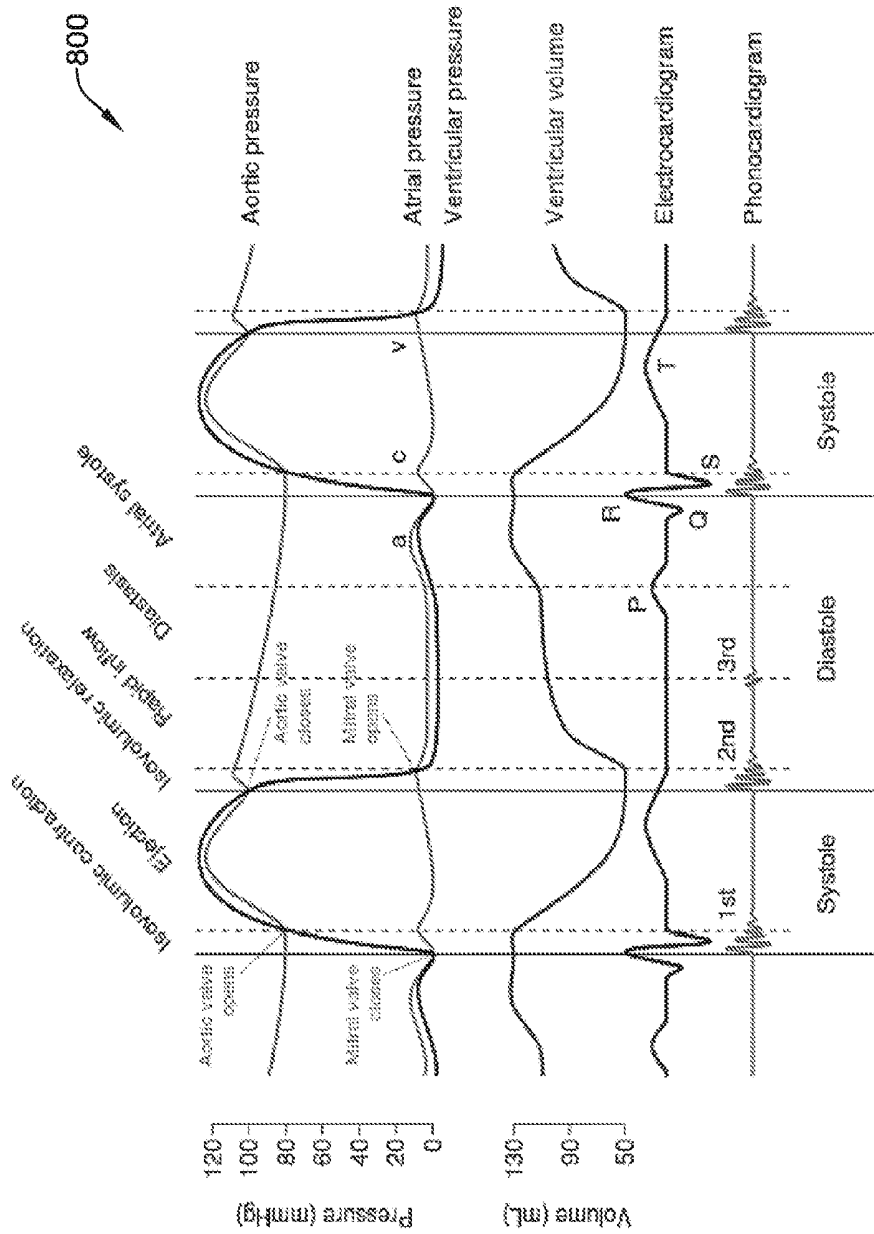

FIG. 8

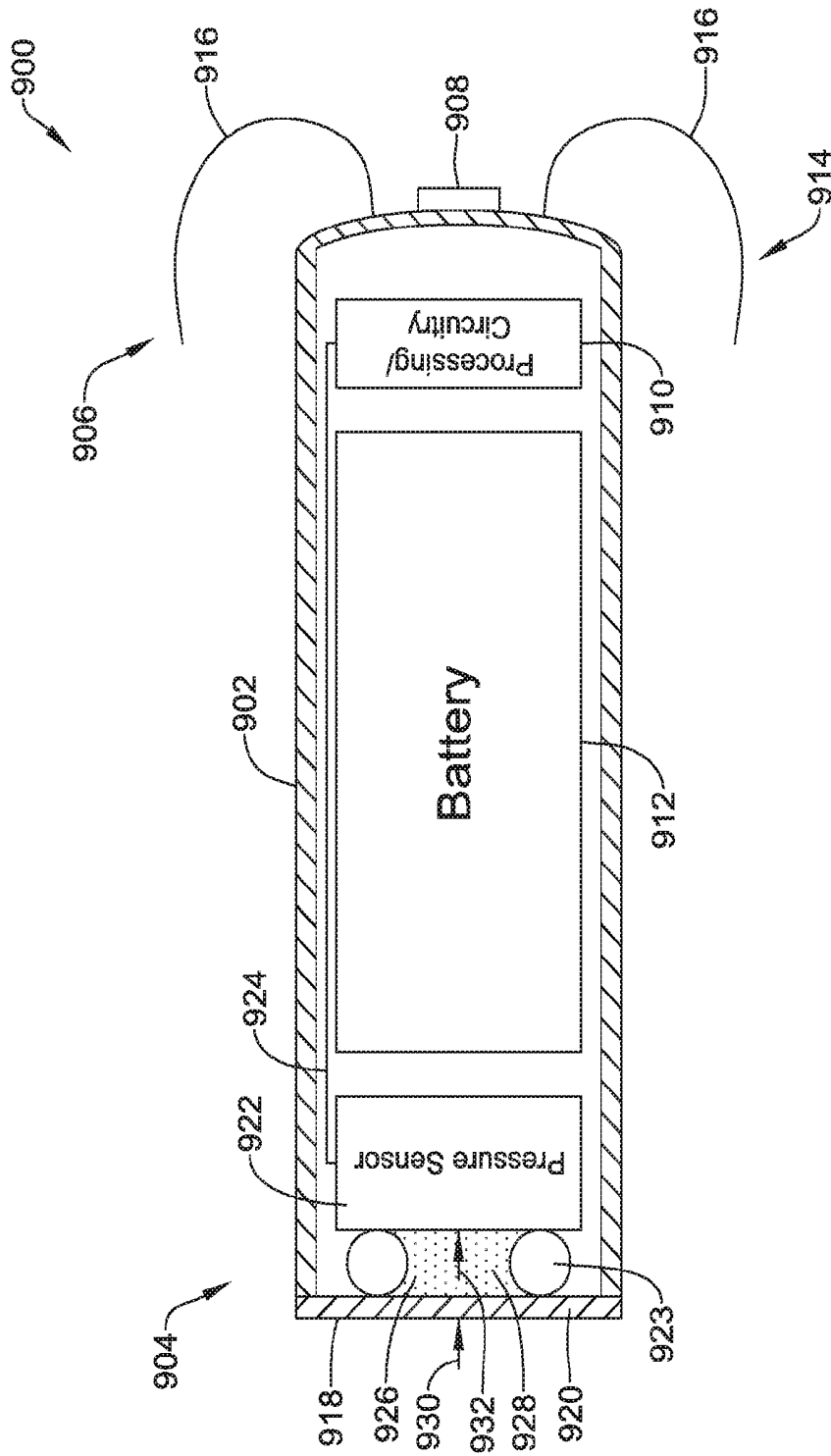

FIG. 9

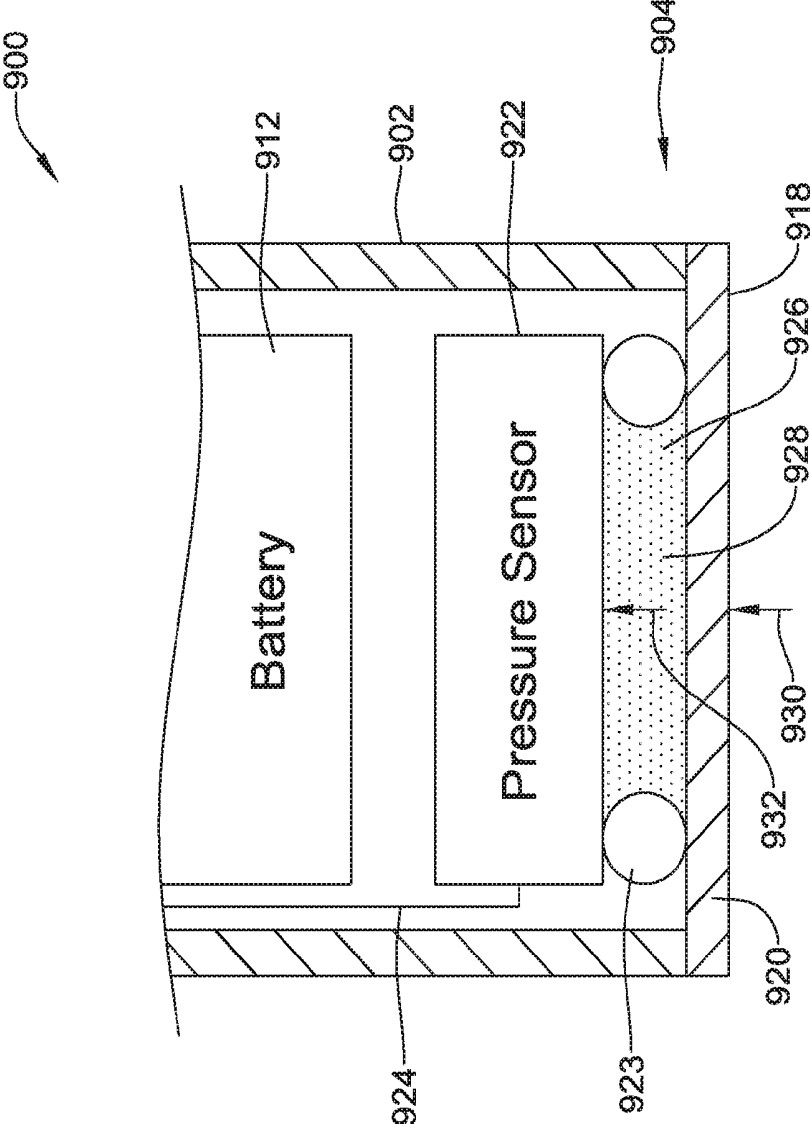

FIG. 10

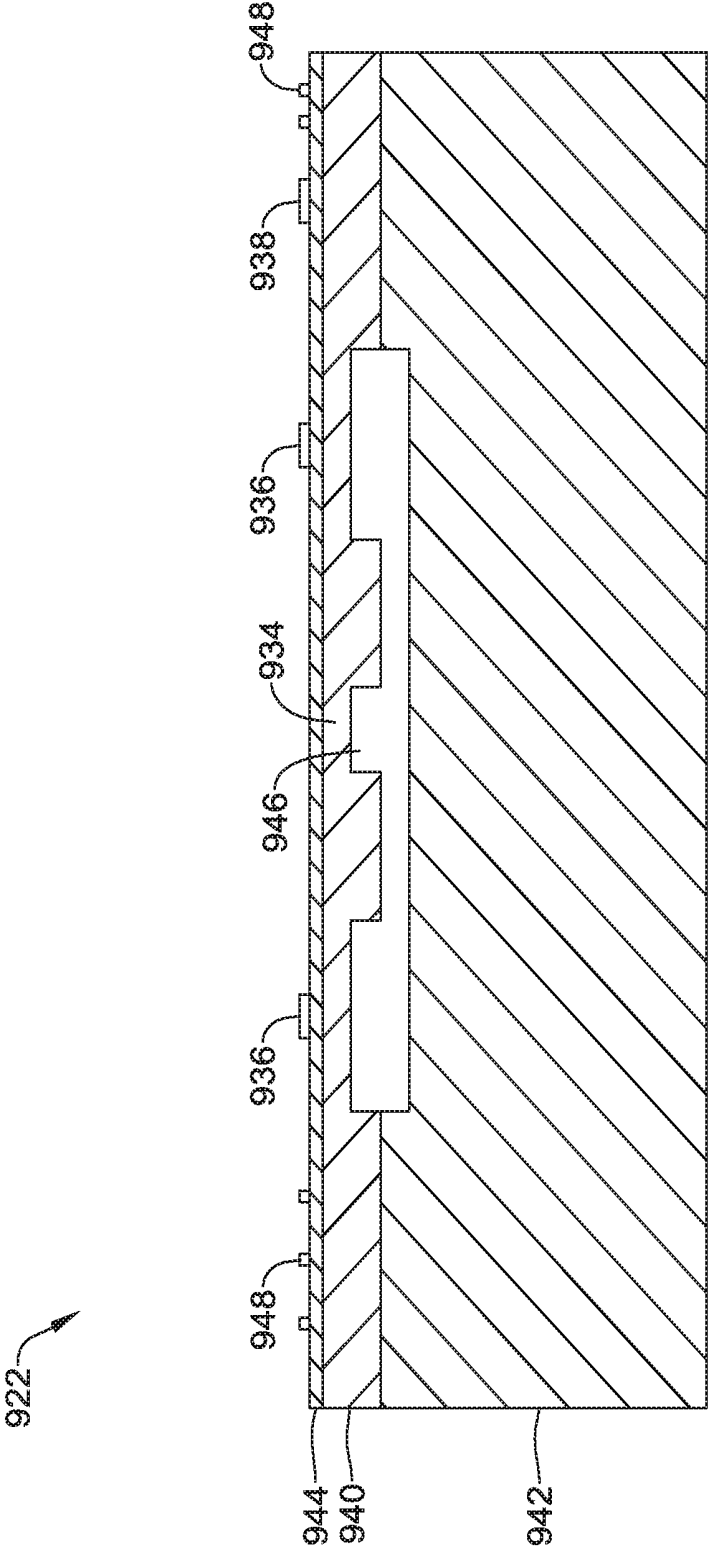

FIG. 11

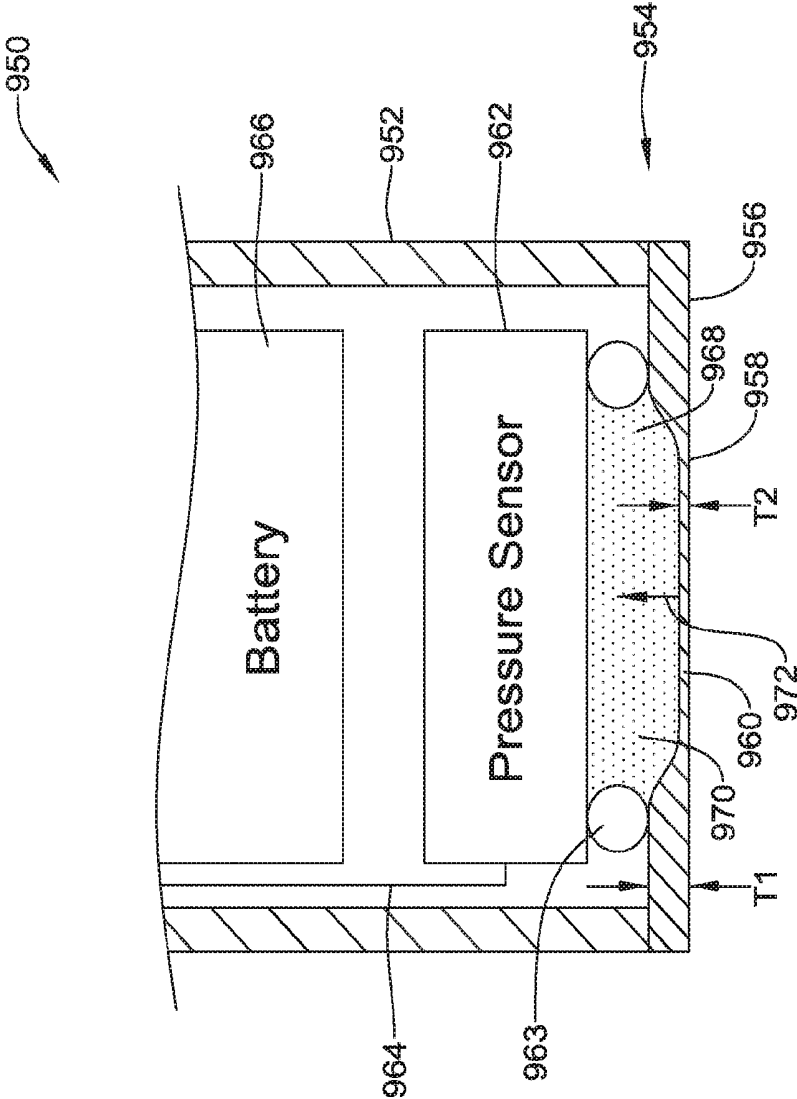

FIG. 12

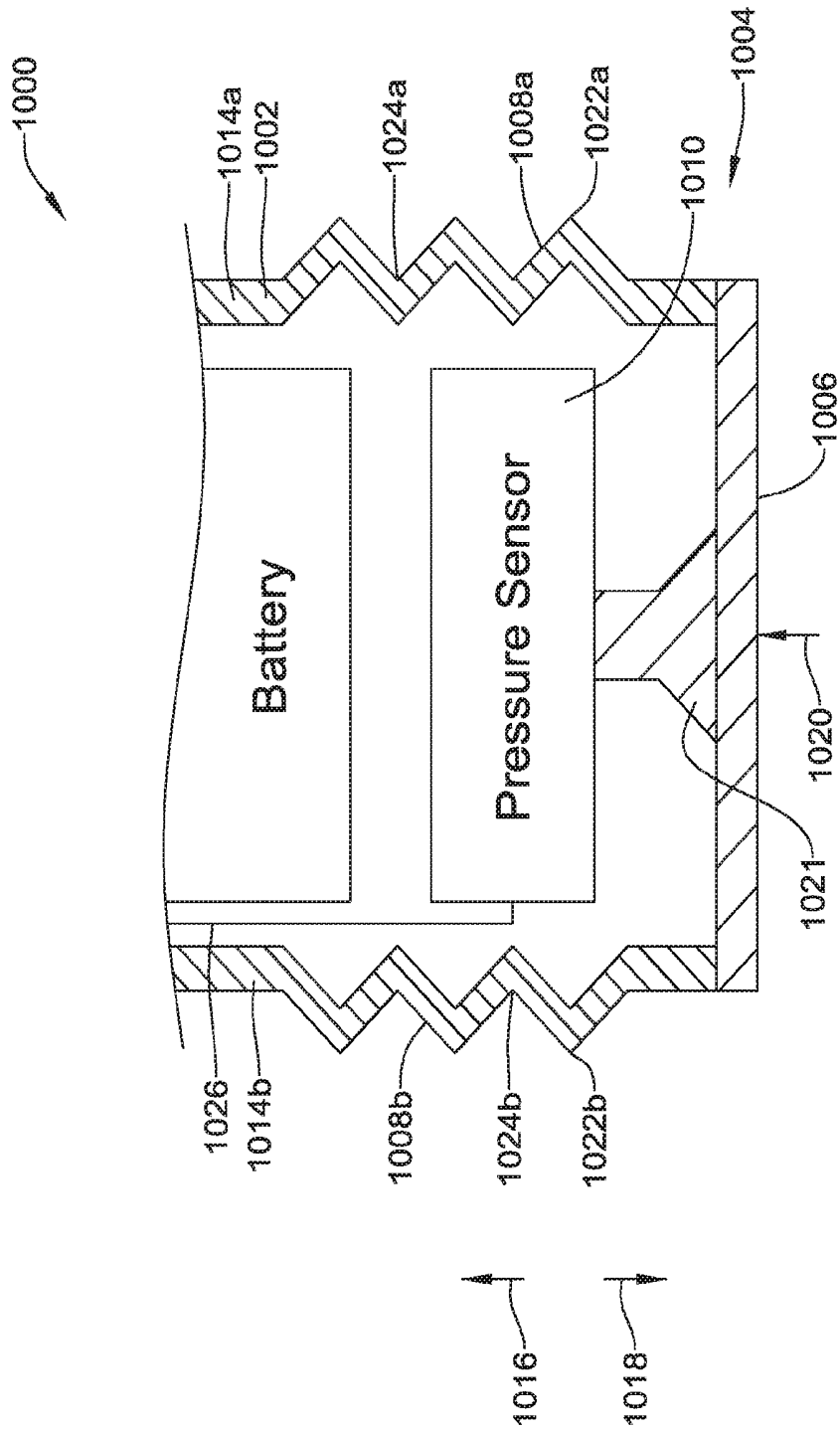

FIG. 13

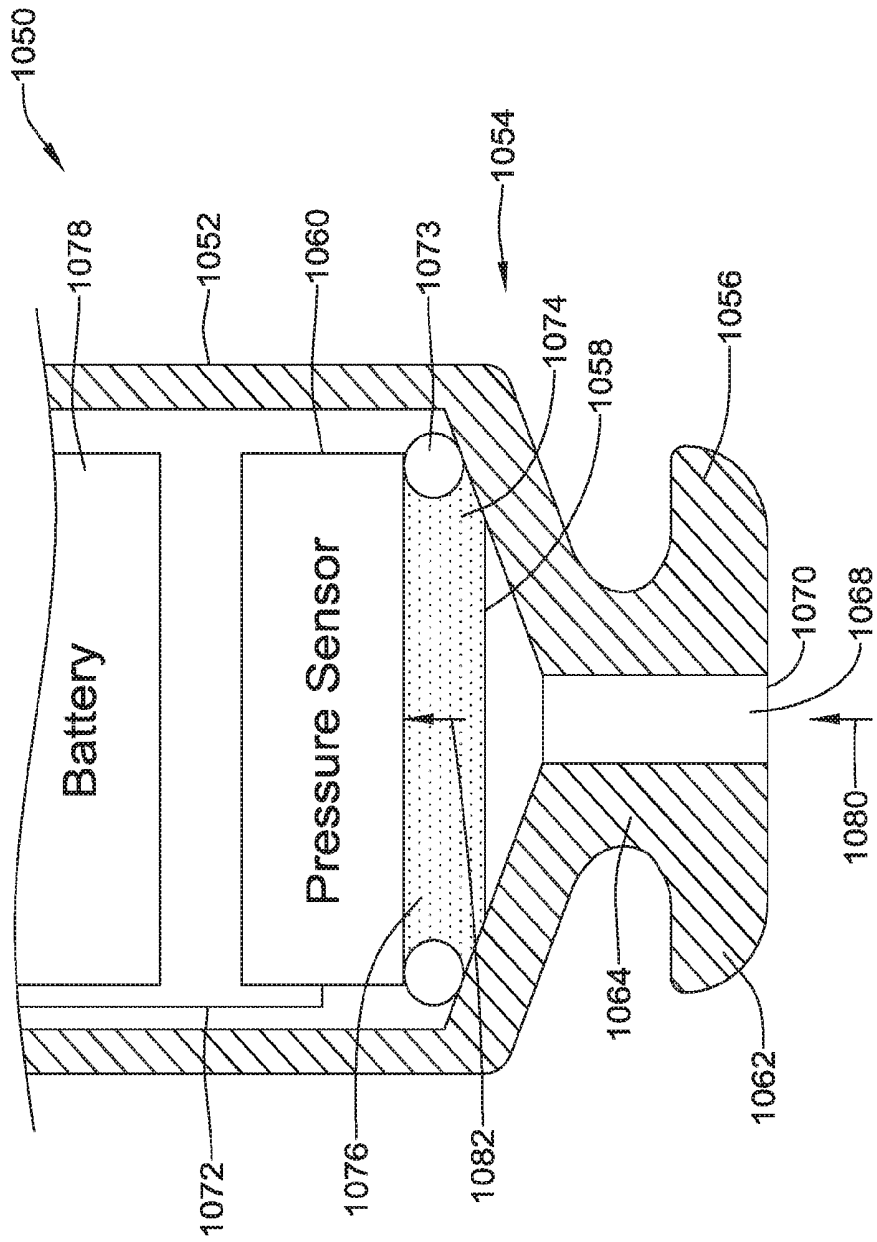

FIG. 14

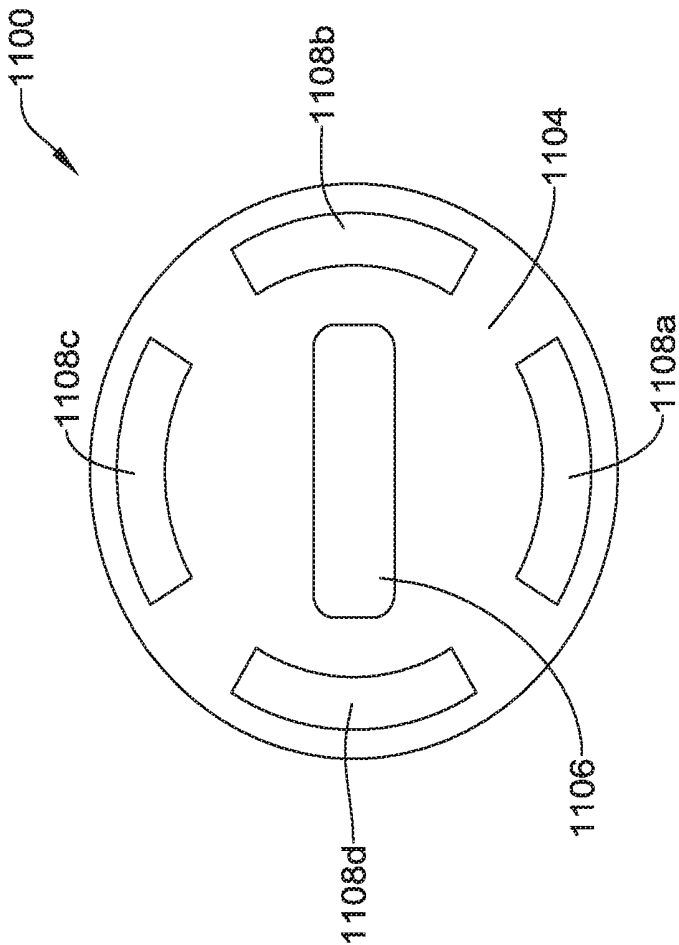

FIG. 15

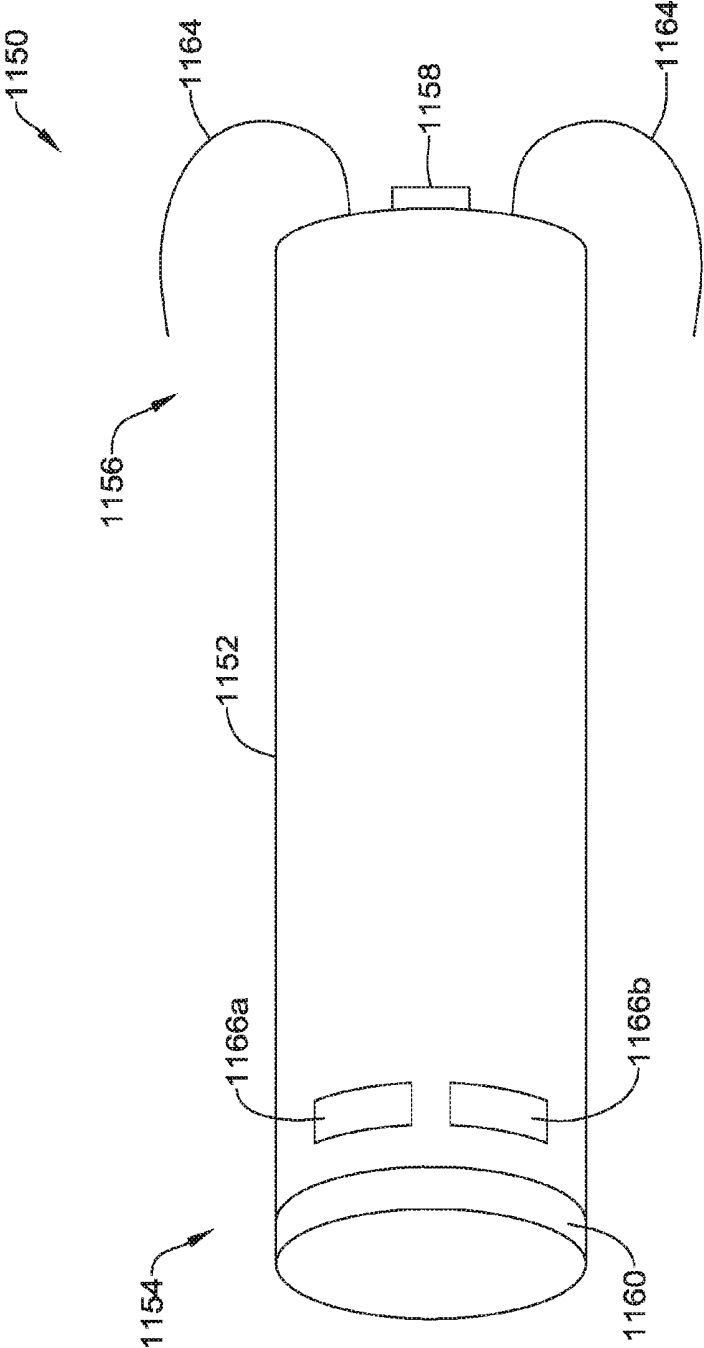

FIG. 16

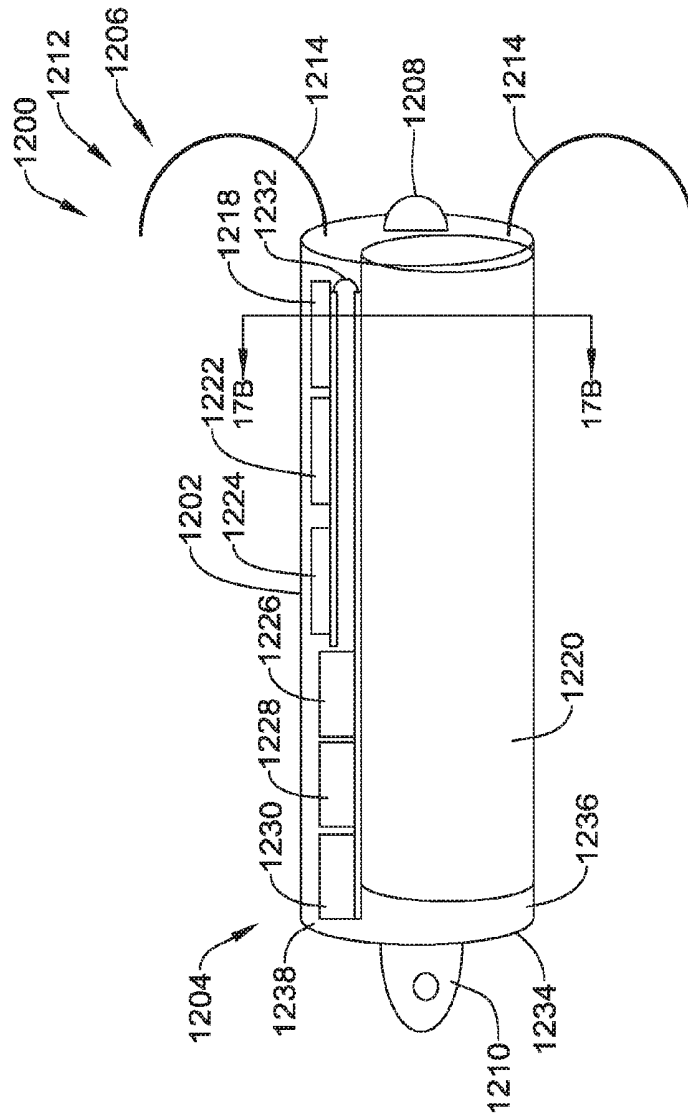

FIG. 17A

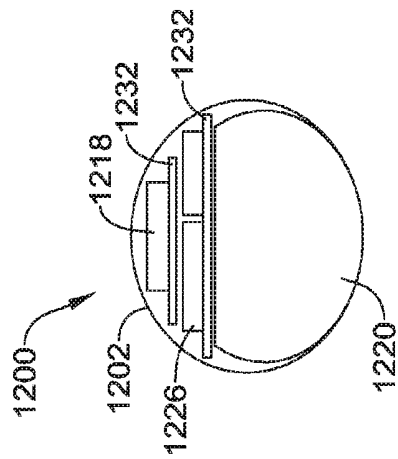

FIG. 17B

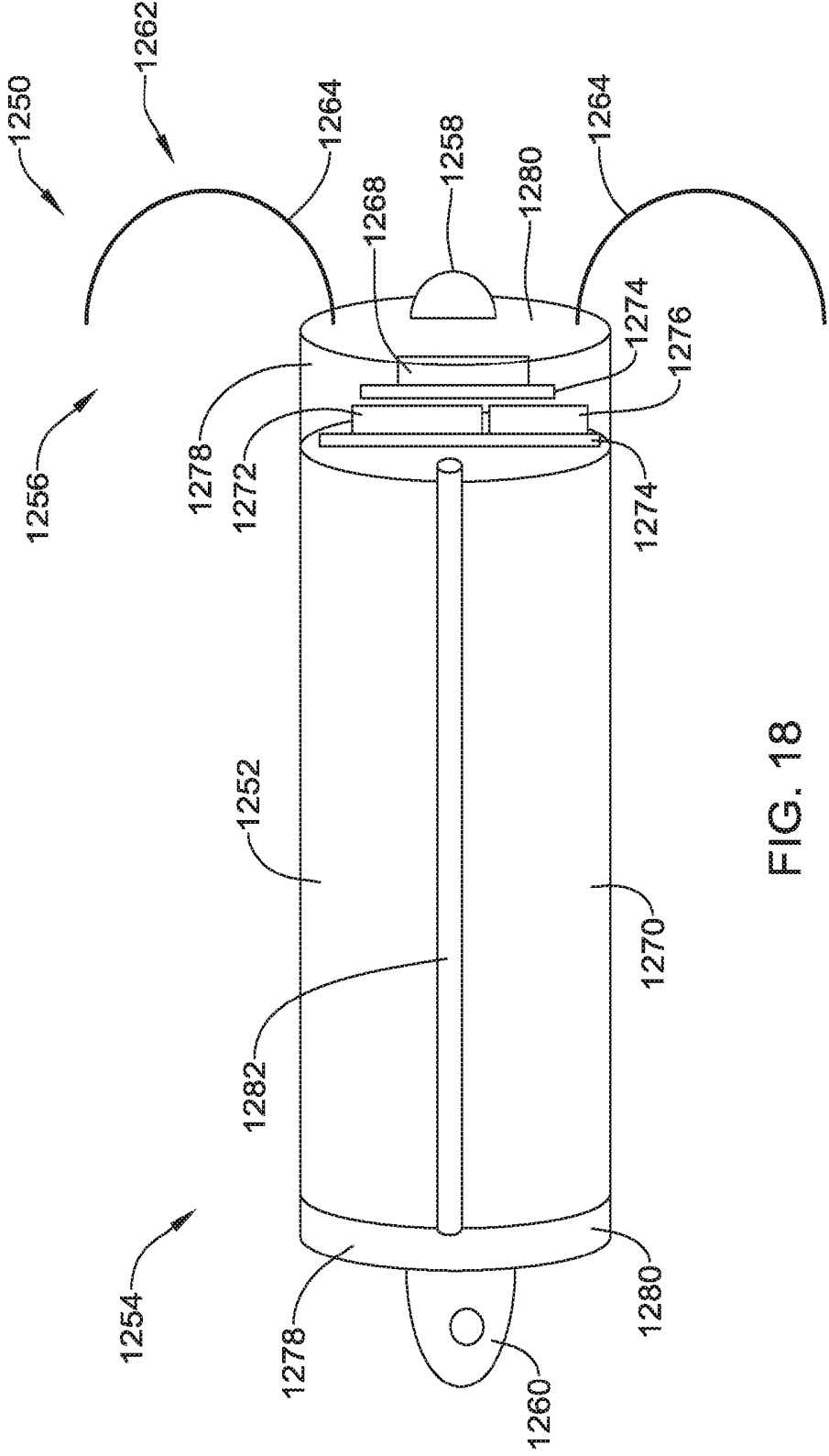

FIG. 18

IMPLANTABLE MEDICAL DEVICE WITH PRESSURE SENSOR

CROSS REFERENCE TO RELATED APPLICATIONS

[0001] This application claims the benefit of U.S. Provisional Patent Application Ser. No. 62/413,766 filed on Oct. 27, 2016, the disclosure of which is incorporated herein by reference.

TECHNICAL FIELD

[0002] The present disclosure generally relates to implantable medical devices and more particularly to implantable medical devices with pressure sensors

BACKGROUND

[0003] Implantable medical devices are commonly used to perform a variety of functions, such as to monitor one or more conditions and/or delivery therapy to a patient. In some cases, an implantable medical device may deliver neurostimulation therapy to a patient. In some cases, an implantable medical device may simply monitor one or more conditions, such as pressure, acceleration, cardiac events, and may communicate the detected conditions or events to another device, such as another implantable medical device or an external programmer.

[0004] In some cases, an implantable medical device may be configured to deliver pacing and/or defibrillation therapy to a patient. Such implantable medical devices may treat patients suffering from various heart conditions that may result in a reduced ability of the heart to deliver sufficient amounts of blood to a patient's body. In some cases, heart conditions may lead to rapid, irregular, and/or inefficient heart contractions. To help alleviate some of these conditions, various devices (e.g., pacemakers, defibrillators, etc.) may be implanted into a patient's body. When so provided, such devices can monitor and provide therapy, such as electrical stimulation therapy, to the patient's heart to help the heart operate in a more normal, efficient and/or safe manner. In some cases, a patient may have multiple implanted devices that cooperate to monitor and/or provide therapy to the patient's heart.

SUMMARY

[0005] The present disclosure generally relates to implantable medical devices and more particularly to implantable medical devices with pressure sensors.

[0006] In a first example, a leadless cardiac pacemaker (LCP) may be configured to sense cardiac activity and to pace a patient's heart. The LCP may comprise a housing having a proximal end and a distal end, a first electrode secured relative to the housing and exposed to the environment outside of the housing, and a second electrode secured relative to the housing and exposed to the environment outside of the housing. The housing may have a diaphragm that is exposed to the environment outside of the housing. The diaphragm may be responsive to a pressure applied to the diaphragm by the environment outside of the housing. A pressure sensor may be within the housing may have a pressure sensor diaphragm that is responsive to a pressure applied to the pressure sensor diaphragm and provides a pressure sensor output signal that is representative of the pressure applied to the pressure sensor diaphragm. A fluid

filled cavity may be in fluid communication with both the diaphragm of the housing and the pressure sensor diaphragm of the pressure sensor. The fluid filled cavity may be configured to communicate a measure related to the pressure applied by the environment to the diaphragm of the housing to the pressure sensor diaphragm of the pressure sensor. Circuitry in the housing may be in operative communication with the pressure sensor. The circuitry may be configured to determine a pressure exterior to the housing based on the pressure sensor output signal.

[0007] Alternatively or additionally to any of the examples above, in another example, the circuitry may be further operatively coupled to the first electrode and the second electrode, and may be further configured to use one or more cardiac signals sensed by the first electrode and the second electrode to determine when the patient's heart is in a first phase of a cardiac cycle and determine a pressure exterior to the housing based at least in part on the pressure sensor output signal taken during the first phase of a cardiac cycle. Alternatively or additionally to any of the examples above, in another example, the first phase of a cardiac cycle may be systole.

[0008] Alternatively or additionally to any of the examples above, in another example, the first phase of a cardiac cycle may be diastole.

[0009] Alternatively or additionally to any of the examples above, in another example, the circuitry may be configured to detect heart sounds of the patient's heart based at least in part on the pressure sensor output signal.

[0010] Alternatively or additionally to any of the examples above, in another example, the diaphragm of the housing may comprise a localized thinning of a housing wall of the housing.

[0011] Alternatively or additionally to any of the examples above, in another example, the diaphragm of the housing may comprise a region comprising a compliant material.

[0012] Alternatively or additionally to any of the examples above, in another example, the diaphragm of the housing may comprise one or more bellows.

[0013] Alternatively or additionally to any of the examples above, in another example, the LCP may further comprise a fixation member at the distal end of the housing for fixing the distal end of the housing to the patient's heart, and wherein the diaphragm of the housing may be adjacent the proximal end of the housing.

[0014] Alternatively or additionally to any of the examples above, in another example, the housing may include an elongated body with a distal end surface facing distally and a proximal end surface facing proximally, wherein the diaphragm of the housing may be situated on the proximal end surface of the housing.

[0015] Alternatively or additionally to any of the examples above, in another example, the housing may have a plurality of diaphragms that are exposed to the environment outside of the housing, each of the plurality of diaphragms are responsive to the pressure applied to the corresponding diaphragm by the environment outside of the housing.

[0016] Alternatively or additionally to any of the examples above, in another example, the fluid filled cavity may be filled with an incompressible fluid.

[0017] Alternatively or additionally to any of the examples above, in another example, the incompressible fluid may be a dielectric fluid.

[0018] Alternatively or additionally to any of the examples above, in another example, the LCP may further comprise an anti-thrombogenic coating disposed over the diaphragm of the housing.

[0019] Alternatively or additionally to any of the examples above, in another example, the diaphragm of the housing may have a first surface area and the pressure sensor diaphragm of the pressure sensor may have a second surface area, wherein a ratio of the first surface area to the second surface area is at least 5 to 1.

[0020] In another example, a leadless cardiac pacemaker (LCP) may be configured to sense cardiac activity and to pace a patient's heart. The LCP may comprise a housing having a proximal end and a distal end, a first electrode secured relative to the housing and exposed to the environment outside of the housing, and a second electrode secured relative to the housing and exposed to the environment outside of the housing. The housing may have a diaphragm that is exposed to the environment outside of the housing. The diaphragm may be responsive to a pressure applied to the diaphragm by the environment outside of the housing. One or more sensors may be coupled to the diaphragm of the housing for detecting a stress in the diaphragm of the housing, wherein the stress in the diaphragm is representative of the pressure applied to the diaphragm by the environment outside of the housing. Circuitry in the housing may be in operative communication with the one or more sensors for determining a pressure exterior to the housing based at least in part on the detected stress in the diaphragm of the housing.

[0021] Alternatively or additionally to any of the examples above, in another example, the diaphragm of the housing may comprise a localized thinning of a housing wall of the housing.

[0022] Alternatively or additionally to any of the examples above, in another example, the localized thinning of the housing wall may comprise a transition from a first thicker wall thickness to a second thinner wall thickness.

[0023] Alternatively or additionally to any of the examples above, in another example, the one or more sensors may comprise a piezo resistor, and wherein the stress in the diaphragm comprises one or more of compression and stretching.

[0024] In another example, an implantable medical device (IMD) may comprise a housing having a proximal end and a distal end, a first electrode secured relative to the housing and exposed to the environment outside of the housing, and a second electrode secured relative to the housing and exposed to the environment outside of the housing. The housing may have a diaphragm that is exposed to the environment outside of the housing. The diaphragm may be responsive to a pressure applied to the diaphragm by the environment outside of the housing. A pressure sensor may be positioned within the housing and may have a pressure sensor diaphragm that is responsive to a pressure applied to the pressure sensor diaphragm and provides a pressure sensor output signal that is representative of the pressure applied to the pressure sensor diaphragm. A fluid filled cavity may be in fluid communication with both the diaphragm of the housing and the pressure sensor diaphragm of the pressure sensor. The fluid filled cavity may be configured to communicate a measure related to the pressure applied by the environment to the diaphragm of the housing to the pressure sensor diaphragm of the pressure sensor. Circuitry

in the housing may be in operative communication with the pressure sensor. The circuitry may be configured to determine a pressure exterior to the housing based on the pressure sensor output signal, and further configured to communicate with another device via the first and second electrodes.

[0025] The above summary is not intended to describe each embodiment or every implementation of the present disclosure. Advantages and attainments, together with a more complete understanding of the disclosure, will become apparent and appreciated by referring to the following description and claims taken in conjunction with the accompanying drawings.

BRIEF DESCRIPTION OF THE DRAWINGS

[0026] The disclosure may be more completely understood in consideration of the following description of various illustrative embodiments in connection with the accompanying drawings, in which:

[0027] FIG. 1 is a schematic block diagram of an illustrative leadless cardiac pacemaker (LCP) according to one example of the present disclosure;

[0028] FIG. 2 is a schematic block diagram of another medical device (MD), which may be used in conjunction with an LCP 100 (FIG. 1) in order to detect and/or treat cardiac arrhythmias and other heart conditions;

[0029] FIG. 3 is a schematic diagram of an exemplary medical system that includes multiple LCPs and/or other devices in communication with one another;

[0030] FIG. 4 is a schematic diagram of an exemplary medical system that includes an LCP and another medical device, in accordance with yet another example of the present disclosure;

[0031] FIG. 5 is a schematic diagram of an exemplary medical system that includes an LCP and another medical device, in accordance with yet another example of the present disclosure;

[0032] FIG. 6 is a side view of an illustrative implantable leadless cardiac pacing device;

[0033] FIG. 7A is a plan view of an example leadless cardiac pacing device implanted within a heart during ventricular filling;

[0034] FIG. 7B is a plan view of an example leadless cardiac pacing device implanted within a heart during ventricular contraction;

[0035] FIG. 8 is a graph showing example pressures and volumes within the heart over time;

[0036] FIG. 9 is a schematic cross-sectional view of an illustrative leadless cardiac pacing device;

[0037] FIG. 10 is a schematic cross-sectional view of the proximal end of the illustrative leadless cardiac pacing device of FIG. 9;

[0038] FIG. 11 is a schematic cross-sectional view of an illustrative pressure sensor for use with a leadless cardiac pacing device;

[0039] FIG. 12 is a schematic cross-sectional view of a proximal end portion of another illustrative leadless cardiac pacing device;

[0040] FIG. 13 is a schematic cross-sectional view of a proximal end portion of another illustrative leadless cardiac pacing device;

[0041] FIG. 14 is a schematic cross-sectional view of a proximal end portion of another illustrative leadless cardiac pacing device;

[0042] FIG. 15 is an end view of the proximal end of another illustrative leadless cardiac pacing device;

[0043] FIG. 16 is a schematic perspective view of another illustrative leadless cardiac pacing device;

[0044] FIG. 17A is a schematic partial cross-sectional view of another illustrative leadless cardiac pacing device;

[0045] FIG. 17B is a cross sectional view of the illustrative leadless cardiac pacing device of FIG. 17A, taken along line 17B-17B; and

[0046] FIG. 18 is a schematic perspective view of another illustrative leadless cardiac pacing device.

[0047] While the disclosure is amenable to various modifications and alternative forms, specifics thereof have been shown by way of example in the drawings and will be described in detail. It should be understood, however, that the intention is not to limit aspects of the disclosure to the particular illustrative embodiments described. On the contrary, the intention is to cover all modifications, equivalents, and alternatives falling within the spirit and scope of the disclosure.

DESCRIPTION

[0048] The following description should be read with reference to the drawings in which similar elements in different drawings are numbered the same. The description and the drawings, which are not necessarily to scale, depict illustrative embodiments and are not intended to limit the scope of the disclosure. While the present disclosure is applicable to any suitable implantable medical device (IMD), the description below uses pacemakers and more particularly leadless cardiac pacemakers (LCP) as particular examples.

[0049] A normal, healthy heart induces contraction by conducting intrinsically generated electrical signals throughout the heart. These intrinsic signals cause the muscle cells or tissue of the heart to contract. This contraction forces blood out of and into the heart, providing circulation of the blood throughout the rest of the body. However, many patients suffer from cardiac conditions that affect this contractility of their hearts. For example, some hearts may develop diseased tissues that no longer generate or conduct intrinsic electrical signals. In some examples, diseased cardiac tissues conduct electrical signals at differing rates, thereby causing an unsynchronized and inefficient contraction of the heart. In other examples, a heart may initiate intrinsic signals at such a low rate that the heart rate becomes dangerously low. In still other examples, a heart may generate electrical signals at an unusually high rate. In some cases such an abnormality can develop into a fibrillation state, where the contraction of the patient's heart chambers are almost completely de-synchronized and the heart pumps very little to no blood. Implantable medical devices, which may be configured to determine occurrences of such cardiac abnormalities or arrhythmias and deliver one or more types of electrical stimulation therapy to patient's hearts, may help to terminate or alleviate these and other cardiac conditions.

[0050] FIG. 1 depicts an illustrative leadless cardiac pacemaker (LCP) that may be implanted into a patient and may operate to prevent, control, or terminate cardiac arrhythmias in patients by, for example, appropriately employing one or more therapies (e.g. anti-tachycardia pacing (ATP) therapy, cardiac resynchronization therapy (CRT), bradycardia therapy, defibrillation pulses, or the like). As can be seen in FIG. 1, the LCP 100 may be a compact device with all

components housed within the LCP 100 or directly on the housing 120. In the example shown in FIG. 1, the LCP 100 may include a communication module 102, a pulse generator module 104, an electrical sensing module 106, a mechanical sensing module 108, a processing module 110, a battery 112, and electrodes 114. The LCP 100 may include more or less modules, depending on the application.

[0051] The communication module 102 may be configured to communicate with devices such as sensors, other medical devices, and/or the like, that are located externally to the LCP 100. Such devices may be located either external or internal to the patient's body. Irrespective of the location, remote devices (i.e. external to the LCP 100 but not necessarily external to the patient's body) can communicate with the LCP 100 via the communication module 102 to accomplish one or more desired functions. For example, the LCP 100 may communicate information, such as sensed electrical signals, data, instructions, messages, etc., to an external medical device through the communication module 102. The external medical device may use the communicated signals, data, instructions and/or messages to perform various functions, such as determining occurrences of arrhythmias, delivering electrical stimulation therapy, storing received data, analyzing received data, and/or performing any other suitable function. The LCP 100 may additionally receive information such as signals, data, instructions and/or messages from the external medical device through the communication module 102, and the LCP 100 may use the received signals, data, instructions and/or messages to perform various functions, such as determining occurrences of arrhythmias, delivering electrical stimulation therapy, storing received data, analyzing received data, and/or performing any other suitable function. The communication module 102 may be configured to use one or more methods for communicating with remote devices. For example, the communication module 102 may communicate via radiofrequency (RF) signals, inductive coupling, optical signals, acoustic signals, conducted communication signals, and/or any other signals suitable for communication.

[0052] In the example shown in FIG. 1, the pulse generator module 104 may be electrically connected to the electrodes 114. In some examples, the LCP 100 may include one or more additional electrodes 114'. In such examples, the pulse generator 104 may also be electrically connected to the additional electrodes 114'. The pulse generator module 104 may be configured to generate electrical stimulation signals. For example, the pulse generator module 104 may generate electrical stimulation signals by using energy stored in a battery 112 within the LCP 100 and deliver the generated electrical stimulation signals via the electrodes 114 and/or 114'. Alternatively, or additionally, the pulse generator 104 may include one or more capacitors, and the pulse generator 104 may charge the one or more capacitors by drawing energy from the battery 112. The pulse generator 104 may then use the energy of the one or more capacitors to deliver the generated electrical stimulation signals via the electrodes 114 and/or 114'. In at least some examples, the pulse generator 104 of the LCP 100 may include switching circuitry to selectively connect one or more of the electrodes 114 and/or 114' to the pulse generator 104 in order to select which of the electrodes 114/114' (and/or other electrodes) the pulse generator 104 delivers the electrical stimulation therapy. The pulse generator module 104 may generate electrical stimulation signals with particular features or in

particular sequences in order to provide one or multiple of a number of different stimulation therapies. For example, the pulse generator module **104** may be configured to generate electrical stimulation signals to provide electrical stimulation therapy to combat bradycardia, tachycardia, cardiac dyssynchrony, bradycardia arrhythmias, tachycardia arrhythmias, fibrillation arrhythmias, cardiac synchronization arrhythmias and/or to produce any other suitable electrical stimulation therapy. Some more common electrical stimulation therapies include bradycardia therapy, anti-tachycardia pacing (ATP) therapy, cardiac resynchronization therapy (CRT), and cardioversion/defibrillation therapy.

[0053] In some examples, the LCP **100** may not include a pulse generator **104** or may turn off the pulse generator **104**. When so provided, the LCP **100** may be a diagnostic only device. In such examples, the LCP **100** may not deliver electrical stimulation therapy to a patient. Rather, the LCP **100** may collect data about cardiac electrical activity and/or physiological parameters of the patient and communicate such data and/or determinations to one or more other medical devices via the communication module **102**.

[0054] In some examples, the LCP **100** may include an electrical sensing module **106**, and in some cases, a mechanical sensing module **108**. The electrical sensing module **106** may be configured to sense the cardiac electrical activity of the heart. For example, the electrical sensing module **106** may be connected to the electrodes **114/114'**, and the electrical sensing module **106** may be configured to receive cardiac electrical signals conducted through the electrodes **114/114'**. The cardiac electrical signals may represent local information from the chamber in which the LCP **100** is implanted. For instance, if the LCP **100** is implanted within a ventricle of the heart, cardiac electrical signals sensed by the LCP **100** through the electrodes **114/114'** may represent ventricular cardiac electrical signals. The mechanical sensing module **108** may include one or more sensors, such as an accelerometer, a blood pressure sensor, a heart sound sensor, a blood-oxygen sensor, a temperature sensor, a flow sensor and/or any other suitable sensors that are configured to measure one or more mechanical and/or chemical parameters of the patient. Both the electrical sensing module **106** and the mechanical sensing module **108** may be connected to a processing module **110**, which may provide signals representative of the sensed mechanical parameters. Although described with respect to FIG. **1** as separate sensing modules, in some cases, the electrical sensing module **106** and the mechanical sensing module **108** may be combined into a single sensing module, as desired.

[0055] The electrodes **114/114'** can be secured relative to the housing **120** but exposed to the tissue and/or blood surrounding the LCP **100**. In some cases, the electrodes **114** may be generally disposed on either end of the LCP **100** and may be in electrical communication with one or more of the modules **102**, **104**, **106**, **108**, and **110**. The electrodes **114/114'** may be supported by the housing **120**, although in some examples, the electrodes **114/114'** may be connected to the housing **120** through short connecting wires such that the electrodes **114/114'** are not directly secured relative to the housing **120**. In examples where the LCP **100** includes one or more electrodes **114'**, the electrodes **114'** may in some cases be disposed on the sides of the LCP **100**, which may increase the number of electrodes by which the LCP **100** may sense cardiac electrical activity, deliver electrical stimulation and/or communicate with an external medical

device. The electrodes **114/114'** can be made up of one or more biocompatible conductive materials such as various metals or alloys that are known to be safe for implantation within a human body. In some instances, the electrodes **114/114'** connected to LCP **100** may have an insulative portion that electrically isolates the electrodes **114/114'** from adjacent electrodes, the housing **120**, and/or other parts of the LCP **100**.

[0056] The processing module **110** can be configured to control the operation of the LCP **100**. For example, the processing module **110** may be configured to receive electrical signals from the electrical sensing module **106** and/or the mechanical sensing module **108**. Based on the received signals, the processing module **110** may determine, for example, occurrences and, in some cases, types of arrhythmias. Based on any determined arrhythmias, the processing module **110** may control the pulse generator module **104** to generate electrical stimulation in accordance with one or more therapies to treat the determined arrhythmia(s). The processing module **110** may further receive information from the communication module **102**. In some examples, the processing module **110** may use such received information to help determine whether an arrhythmia is occurring, determine a type of arrhythmia, and/or to take particular action in response to the information. The processing module **110** may additionally control the communication module **102** to send/receive information to/from other devices.

[0057] In some examples, the processing module **110** may include a pre-programmed chip, such as a very-large-scale integration (VLSI) chip and/or an application specific integrated circuit (ASIC). In such embodiments, the chip may be pre-programmed with control logic in order to control the operation of the LCP **100**. By using a pre-programmed chip, the processing module **110** may use less power than other programmable circuits (e.g. general purpose programmable microprocessors) while still being able to maintain basic functionality, thereby potentially increasing the battery life of the LCP **100**. In other examples, the processing module **110** may include a programmable microprocessor. Such a programmable microprocessor may allow a user to modify the control logic of the LCP **100** even after implantation, thereby allowing for greater flexibility of the LCP **100** than when using a pre-programmed ASIC. In some examples, the processing module **110** may further include a memory, and the processing module **110** may store information on and read information from the memory. In other examples, the LCP **100** may include a separate memory (not shown) that is in communication with the processing module **110**, such that the processing module **110** may read and write information to and from the separate memory.

[0058] The battery **112** may provide power to the LCP **100** for its operations. In some examples, the battery **112** may be a non-rechargeable lithium-based battery. In other examples, a non-rechargeable battery may be made from other suitable materials, as desired. Because the LCP **100** is an implantable device, access to the LCP **100** may be limited after implantation. Accordingly, it is desirable to have sufficient battery capacity to deliver therapy over a period of treatment such as days, weeks, months, years or even decades. In some instances, the battery **112** may be a rechargeable battery, which may help increase the useable lifespan of the LCP **100**. In still other examples, the battery **112** may be some other type of power source, as desired.

[0059] To implant the LCP 100 inside a patient's body, an operator (e.g., a physician, clinician, etc.), may fix the LCP 100 to the cardiac tissue of the patient's heart. To facilitate fixation, the LCP 100 may include one or more anchors 116. The anchor 116 may include any one of a number of fixation or anchoring mechanisms. For example, the anchor 116 may include one or more pins, staples, threads, screws, helix, tines, and/or the like. In some examples, although not shown, the anchor 116 may include threads on its external surface that may run along at least a partial length of the anchor 116. The threads may provide friction between the cardiac tissue and the anchor to help fix the anchor 116 within the cardiac tissue. In other examples, the anchor 116 may include other structures such as barbs, spikes, or the like to facilitate engagement with the surrounding cardiac tissue.

[0060] FIG. 2 depicts an example of another medical device (MD) 200, which may be used in conjunction with an LCP 100 (FIG. 1) in order to detect and/or treat cardiac arrhythmias and other heart conditions. In the example shown, the MD 200 may include a communication module 202, a pulse generator module 204, an electrical sensing module 206, a mechanical sensing module 208, a processing module 210, and a battery 218. Each of these modules may be similar to the modules 102, 104, 106, 108, and 110 of the LCP 100. Additionally, the battery 218 may be similar to the battery 112 of the LCP 100. In some examples, the MD 200 may have a larger volume within the housing 220 than LCP 100. In such examples, the MD 200 may include a larger battery and/or a larger processing module 210 capable of handling more complex operations than the processing module 110 of the LCP 100.

[0061] While it is contemplated that the MD 200 may be another leadless device such as shown in FIG. 1, in some instances the MD 200 may include leads such as leads 212. The leads 212 may include electrical wires that conduct electrical signals between the electrodes 214 and one or more modules located within the housing 220. In some cases, the leads 212 may be connected to and extend away from the housing 220 of the MD 200. In some examples, the leads 212 are implanted on, within, or adjacent to a heart of a patient. The leads 212 may contain one or more electrodes 214 positioned at various locations on the leads 212, and in some cases at various distances from the housing 220. Some of the leads 212 may only include a single electrode 214, while other leads 212 may include multiple electrodes 214. Generally, the electrodes 214 are positioned on the leads 212 such that when the leads 212 are implanted within the patient, one or more of the electrodes 214 are positioned to perform a desired function. In some cases, the one or more of the electrodes 214 may be in contact with the patient's cardiac tissue. In some cases, the one or more of the electrodes 214 may be positioned subinternally or subcutaneously but adjacent the patient's heart. In some cases, the electrodes 214 may conduct intrinsically generated electrical signals to the leads 212, e.g. signals representative of intrinsic cardiac electrical activity. The leads 212 may, in turn, conduct the received electrical signals to one or more of the modules 202, 204, 206, and 208 of the MD 200. In some cases, the MD 200 may generate electrical stimulation signals, and the leads 212 may conduct the generated electrical stimulation signals to the electrodes 214. The electrodes 214 may then conduct the electrical signals and delivery the signals to the patient's heart (either directly or indirectly).

[0062] The mechanical sensing module 208, as with the mechanical sensing module 108, may contain or be electrically connected to one or more sensors, such as accelerometers, blood pressure sensors, heart sound sensors, blood-oxygen sensors, acoustic sensors, ultrasonic sensors and/or other sensors which are configured to measure one or more mechanical/chemical parameters of the heart and/or patient. In some examples, one or more of the sensors may be located on the leads 212, but this is not required. In some examples, one or more of the sensors may be located in the housing 220.

[0063] While not required, in some examples, the MD 200 may be an implantable medical device. In such examples, the housing 220 of the MD 200 may be implanted in, for example, a transthoracic region of the patient. The housing 220 may generally include any of a number of known materials that are safe for implantation in a human body and may, when implanted, hermetically seal the various components of the MD 200 from fluids and tissues of the patient's body.

[0064] In some cases, the MD 200 may be an implantable cardiac pacemaker (ICP). In this example, the MD 200 may have one or more leads, for example leads 212, which are implanted on or within the patient's heart. The one or more leads 212 may include one or more electrodes 214 that are in contact with cardiac tissue and/or blood of the patient's heart. The MD 200 may be configured to sense intrinsically generated cardiac electrical signals and determine, for example, one or more cardiac arrhythmias based on analysis of the sensed signals. The MD 200 may be configured to deliver CRT, ATP therapy, bradycardia therapy, and/or other therapy types via the leads 212 implanted within the heart or in concert with the LCP by commanding the LCP to pace. In some examples, the MD 200 may additionally be configured provide defibrillation therapy.

[0065] In some instances, the MD 200 may be an implantable cardioverter-defibrillator (ICD). In such examples, the MD 200 may include one or more leads implanted within a patient's heart. The MD 200 may also be configured to sense cardiac electrical signals, determine occurrences of tachyarrhythmias based on the sensed signals, and may be configured to deliver defibrillation therapy in response to determining an occurrence of a tachyarrhythmia. In some instances, the MD 200 may be a subcutaneous implantable cardioverter-defibrillator (S-ICD). In examples where the MD 200 is an S-ICD, one of the leads 212 may be a subcutaneously implanted lead. In at least some examples where the MD 200 is an S-ICD, the MD 200 may include only a single lead which is implanted subcutaneously, but this is not required. In some cases, the S-ICD lead may extend subcutaneously from the S-ICD can, around the sternum and may terminate adjacent the interior surface of the sternum.

[0066] In some examples, the MD 200 may not be an implantable medical device. Rather, the MD 200 may be a device external to the patient's body, and may include skin-electrodes that are placed on a patient's body. In such examples, the MD 200 may be able to sense surface electrical signals (e.g. cardiac electrical signals that are generated by the heart or electrical signals generated by a device implanted within a patient's body and conducted through the body to the skin). In such examples, the MD 200 may be configured to deliver various types of electrical stimulation therapy, including, for example, defibrillation therapy. The

MD 200 may be further configured to deliver electrical stimulation via the LCP by commanding the LCP to deliver the therapy.

[0067] FIG. 3 shows an example medical device system with a communication pathway through which multiple medical devices 302, 304, 306, and/or 310 may communicate. In the example shown, the medical device system 300 may include LCPs 302 and 304, an external medical device 306, and other sensors/devices 310. The external device 306 may be any of the devices described previously with respect to MD 200. In some embodiments, the external device 306 may be provided with or be in communication with a display 312. The display 312 may be a personal computer, tablet computer, smart phone, laptop computer, or other display as desired. In some instances, the display 312 may include input means for receiving an input from a user. For example, the display 312 may also include a keyboard, mouse, actuable (e.g. pushable) buttons, or a touchscreen display. These are just examples. The other sensors/devices 310 may be any of the devices described previously with respect to the MD 200. In some instances, the other sensors/devices 310 may include a sensor, such as an accelerometer or blood pressure sensor, or the like. In some cases, the other sensors/devices 310 may include an external programmer device that may be used to program one or more devices of the system 300.

[0068] Various devices of the system 300 may communicate via a communication pathway 308. For example, the LCPs 302 and/or 304 may sense intrinsic cardiac electrical signals and may communicate such signals to one or more other devices 302/304, 306, and 310 of the system 300 via the communication pathway 308. In one example, one or more of the devices 302/304 may receive such signals and, based on the received signals, determine an occurrence of an arrhythmia. In some cases, the device or devices 302/304 may communicate such determinations to one or more other devices 306 and 310 of the system 300. In some cases, one or more of the devices 302/304, 306, and 310 of the system 300 may take action based on the communicated determination of an arrhythmia, such as by delivering a suitable electrical stimulation to the heart of the patient. In another example, the LCPs 302 and/or 304 may sense indications of blood pressure (e.g. via one or more pressure sensors) and indications of volume (e.g. via an impedance between the electrodes of an LCP or between LCPs via an ultrasound transducer placed within the LCP, or via strain sensors placed on the heart in communication with the LCP). In one example, one or more of the devices 302/304 may receive such signals and, based on the received signals, determine a pressure-volume loop, and in some cases may communicate such information to one or more other devices 302/304, 306, and 310 of the system 300 via the communication pathway 308.

[0069] It is contemplated that the communication pathway 308 may communicate using RF signals, inductive coupling, conductive coupling optical signals, acoustic signals, or any other signals suitable for communication. Additionally, in at least some examples, the device communication pathway 308 may comprise multiple signal types. For instance, the other sensors/device 310 may communicate with the external device 306 using a first signal type (e.g. RF communication) but communicate with the LCPs 302/304 using a second signal type (e.g. conducted communication, inductive communication). Further, in some examples, commu-

nication between devices may be limited. For instance, as described above, in some examples, the LCPs 302/304 may communicate with the external device 306 only through the other sensors/devices 310, where the LCPs 302/304 send signals to the other sensors/devices 310, and the other sensors/devices 310 relay the received signals to the external device 306.

[0070] In some cases, the communication pathway 308 may include conducted communication. Accordingly, devices of the system 300 may have components that allow for such conducted communication. For instance, the devices of the system 300 may be configured to transmit conducted communication signals (e.g. current and/or voltage pulses) into the patient's body via one or more electrodes of a transmitting device, and may receive the conducted communication signals (e.g. pulses) via one or more electrodes of a receiving device. The patient's body may "conduct" the conducted communication signals (e.g. pulses) from the one or more electrodes of the transmitting device to the electrodes of the receiving device in the system 300. In such examples, the delivered conducted communication signals (e.g. pulses) may differ from pacing or other therapy signals. For example, the devices of the system 300 may deliver electrical communication pulses at an amplitude/pulse width that is sub-threshold to the heart. Although, in some cases, the amplitude/pulse width of the delivered electrical communication pulses may be above the capture threshold of the heart, but may be delivered during a refractory period of the heart and/or may be incorporated in or modulated onto a pacing pulse, if desired.

[0071] Delivered electrical communication pulses may be modulated in any suitable manner to encode communicated information. In some cases, the communication pulses may be pulse width modulated or amplitude modulated. Alternatively, or in addition, the time between pulses may be modulated to encode desired information. In some cases, conducted communication pulses may be voltage pulses, current pulses, biphasic voltage pulses, biphasic current pulses, or any other suitable electrical pulse as desired.

[0072] In some cases, the communication pathway 308 may include inductive communication, and when so provided, the devices of the system 300 may be configured to transmit/receive inductive communication signals.

[0073] FIGS. 4 and 5 show illustrative medical device systems that may be configured to operate according to techniques disclosed herein. In FIG. 4, an LCP 402 is shown fixed to the interior of the left ventricle of the heart 410, and a pulse generator 406 is shown coupled to a lead 412 having one or more electrodes 408a, 408b, 408c. In some cases, the pulse generator 406 may be part of a subcutaneous implantable cardioverter-defibrillator (S-ICD), and the one or more electrodes 408a, 408b, 408c may be positioned subcutaneously adjacent the heart. In some cases, the S-ICD lead may extend subcutaneously from the S-ICD can, around the sternum and one or more electrodes 408a, 408b, 408c may be positioned adjacent the interior surface of the sternum. In some cases, the LCP 402 may communicate with the subcutaneous implantable cardioverter-defibrillator (S-ICD).

[0074] In some cases, the LCP 402 may be in the right ventricle, right atrium or left atrium of the heart, as desired. In some cases, more than one LCP 402 may be implanted. For example, one LCP may be implanted in the right ventricle and another may be implanted in the right atrium. In another example, one LCP may be implanted in the right

ventricle and another may be implanted in the left ventricle. In yet another example, one LCP may be implanted in each of the chambers of the heart.

[0075] In FIG. 5, an LCP 502 is shown fixed to the interior of the left ventricle of the heart 510, and a pulse generator 506 is shown coupled to a lead 512 having one or more electrodes 504a, 504b, 504c. In some cases, the pulse generator 506 may be part of an implantable cardiac pacemaker (ICP) and/or an implantable cardioverter-defibrillator (ICD), and the one or more electrodes 504a, 504b, 504c may be positioned in the heart 510. In some cases, the LCP 502 may communicate with the implantable cardiac pacemaker (ICP) and/or an implantable cardioverter-defibrillator (ICD).

[0076] The medical device systems 400 and 500 may also include an external support device, such as external support devices 420 and 520. The external support devices 420 and 520 can be used to perform functions such as device identification, device programming and/or transfer of real-time and/or stored data between devices using one or more of the communication techniques described herein. As one example, communication between the external support device 420 and the pulse generator 406 is performed via a wireless mode, and communication between the pulse generator 406 and the LCP 402 is performed via a conducted mode. In some examples, communication between the LCP 402 and the external support device 420 is accomplished by sending communication information through the pulse generator 406. However, in other examples, communication between the LCP 402 and the external support device 420 may be via a communication module. In some embodiments, the external support devices 420, 520 may be provided with or be in communication with a display 422, 522. The display 422, 522 may be a personal computer, tablet computer, smart phone, laptop computer, or other display as desired. In some instances, the display 422, 522 may include input means for receiving an input from a user. For example, the display 422, 522 may also include a keyboard, mouse, actuatable buttons, or be a touchscreen display. These are just examples.

[0077] FIGS. 4-5 illustrate two examples of medical device systems that may be configured to operate according to techniques disclosed herein. Other example medical device systems may include additional or different medical devices and/or configurations. For instance, other medical device systems that are suitable to operate according to techniques disclosed herein may include additional LCPs implanted within the heart. Another example medical device system may include a plurality of LCPs without other devices such as the pulse generator 406 or 506, with at least one LCP capable of delivering defibrillation therapy. In yet other examples, the configuration or placement of the medical devices, leads, and/or electrodes may be different from those depicted in FIGS. 4 and 5. Accordingly, it should be recognized that numerous other medical device systems, different from those depicted in FIGS. 4 and 5, may be operated in accordance with techniques disclosed herein. As such, the examples shown in FIGS. 4 and 5 should not be viewed as limiting in any way.

[0078] FIG. 6 is a side view of an illustrative implantable leadless cardiac pacemaker (LCP) 610. The LCP 610 may be similar in form and function to the LCP 100 described above. The LCP 610 may include any of the modules and/or structural features described herein. The LCP 610 may include a shell or housing 612 having a proximal end 614 and a distal end 616. The illustrative LCP 610 includes a first

electrode 620 secured relative to the housing 612 and positioned adjacent to the distal end 616 of the housing 612 and a second electrode 622 secured relative to the housing 612 and positioned adjacent to the proximal end 614 of the housing 612. In some cases, the housing 612 may include a conductive material and may be insulated along a portion of its length. A section along the proximal end 614 may be free of insulation so as to define the second electrode 622. The electrodes 620, 622 may be sensing and/or pacing electrodes to provide electro-therapy and/or sensing capabilities. The first electrode 620 may be capable of being positioned against or may otherwise contact the cardiac tissue of the heart while the second electrode 622 may be spaced away from the first electrode 620. The first and/or second electrodes 620, 622 may be exposed to the environment outside the housing 612 (e.g. to blood and/or tissue).

[0079] It is contemplated that the housing 612 may take a variety of different shapes. For example, in some cases, the housing 612 may have a generally cylindrical shape. In other cases, the housing 612 may have a half-dome shape. In yet other embodiments, the housing 612 may be a rectangular prism. It is contemplated that the housing may take any cross sectional shape desired, including but not limited to annular, polygonal, oblong, square, etc.

[0080] In some cases, the LCP 610 may include a pulse generator (e.g., electrical circuitry) and a power source (e.g., a battery) within the housing 612 to provide electrical signals to the electrodes 620, 622 to control the pacing/sensing electrodes 620, 622. While not explicitly shown, the LCP 610 may also include a communications module, an electrical sensing module, a mechanical sensing module, and/or a processing module, and the associated circuitry, similar in form and function to the modules 102, 106, 108, 110 described above. The various modules and electrical circuitry may be disposed within the housing 612. Electrical communication between the pulse generator and the electrodes 620, 622 may provide electrical stimulation to heart tissue and/or sense a physiological condition.

[0081] In the example shown, the LCP 610 includes a fixation mechanism 624 proximate the distal end 616 of the housing 612. The fixation mechanism 624 is configured to attach the LCP 610 to a wall of the heart H, or otherwise anchor the LCP 610 to the anatomy of the patient. As shown in FIG. 6, in some instances, the fixation mechanism 624 may include one or more, or a plurality of hooks or tines 626 anchored into the cardiac tissue of the heart H to attach the LCP 610 to a tissue wall. In other instances, the fixation mechanism 624 may include one or more, or a plurality of passive tines, configured to entangle with trabeculae within the chamber of the heart H and/or a helical fixation anchor configured to be screwed into a tissue wall to anchor the LCP 610 to the heart H. These are just examples.

[0082] The LCP 610 may further include a docking member 630 proximate the proximal end 614 of the housing 612. The docking member 630 may be configured to facilitate delivery and/or retrieval of the LCP 610. For example, the docking member 630 may extend from the proximal end 614 of the housing 612 along a longitudinal axis of the housing 612. The docking member 630 may include a head portion 632 and a neck portion 634 extending between the housing 612 and the head portion 632. The head portion 632 may be an enlarged portion relative to the neck portion 634. For example, the head portion 632 may have a radial dimension from the longitudinal axis of the LCP 610 that is greater than

a radial dimension of the neck portion **634** from the longitudinal axis of the LCP **610**. In some cases, the docking member **630** may further include a tether retention structure (not explicitly shown) extending from or recessed within the head portion **632**. The tether retention structure may define an opening configured to receive a tether or other anchoring mechanism therethrough. The retention structure may take any shape that provides an enclosed perimeter surrounding the opening such that a tether may be securably and releasably passed (e.g. looped) through the opening. In some cases, the retention structure may extend through the head portion **632**, along the neck portion **634**, and to or into the proximal end **614** of the housing **612**. The docking member **630** may be configured to facilitate delivery of the LCP **610** to the intracardiac site and/or retrieval of the LCP **610** from the intracardiac site. While this describes one example docking member **630**, it is contemplated that the docking member **630**, when provided, can have any suitable configuration.

[0083] It is contemplated that the LCP **610** may include one or more pressure sensors **640** coupled to or formed within the housing **612** such that the pressure sensor(s) is exposed to and/or otherwise operationally coupled with the environment outside the housing **612** to measure blood pressures within the heart. In some cases, the one or more pressure sensors **640** may be coupled to an exterior surface of the housing **612**. In other cases, the one or more pressure sensors **640** may be positioned within the housing **612** with a pressure acting on the housing and/or a port on the housing **612** to affect the pressure sensor **640**. For example, if the LCP **610** is placed in the left ventricle, the pressure sensor(s) **640** may measure the pressure within the left ventricle. If the LCP **610** is placed in another portion of the heart (such as one of the atriums or the right ventricle), the pressure sensor(s) may measure the pressure within that portion of the heart. Some illustrative pressure sensor configurations will be described in more detail herein.

[0084] The pressure sensor(s) **640** may include a MEMS device, such as a MEMS device with a pressure diaphragm and piezoresistors on the diaphragm, a piezoelectric sensor, a capacitor-Micro-machined Ultrasonic Transducer (cMUT), a condenser, a micromanometer, a surface acoustic wave (SAW) device, or any other suitable sensor adapted for measuring cardiac pressure. The pressure sensor(s) **640** may be part of a mechanical sensing module described herein. It is contemplated that the pressure measurements obtained from the pressure sensor(s) **640** may be used to generate a pressure curve over cardiac cycles. The pressure sensor(s) **640** may measure/sense pressure in the chamber in which the LCP **610** is implanted. For example, an LCP **610** implanted in the left ventricle (LV) could sense LV pressure. The pressure sensor(s) **640** may be configured (either alone or in combination with other circuitry in the LCP **610**) to derive change in pressure over time and used to adjust atrium to ventricle pacing delay to optimize cardiac resynchronization therapy (CRT). In some cases, the pressure sensor(s) **640** may be configured to detect a-waves and change the pacing timing of the LCP **610** for CRT optimization. It is further contemplated that sensing pressure could be used during the implant procedure to optimize the placement of the LCP **610** in the chamber (e.g., LV by sampling at different implant locations and using the best location). Frequent pressure monitoring may be beneficial for management of heart failure patients. Frequent pressure moni-

toring may also be useful for patients with chronic heart disease, hypertension, regurgitation, valve issues, atrial contraction detection, and to aid in addressing other problems. It is further contemplated that the pressure sensor(s) **640** may be used for monitoring respiration and associated diseases (e.g., chronic obstructive pulmonary disease (COPD), etc.). These are just examples.

[0085] In some cases, pressure readings may be taken in combination with a cardiac chamber volume measurement such as an impedance measurement (e.g. the impedance between electrodes **620** and **622**) to generate a pressure-impedance loop for one or more cardiac cycles. The impedance may be a surrogate for chamber volume, and thus the pressure-impedance loop may be representative of a pressure-volume loop for the heart H.

[0086] FIG. 7A is a plan view of the example leadless cardiac pacing device **610** implanted within a left ventricle LV of the heart H during ventricular filling. The right ventricle RV, right atrium RA, left atrium LA, and aorta A are also illustrated. FIG. 7B is a plan view of the leadless cardiac pacing device **610** implanted within a left ventricle of the heart H during ventricular contraction. These figures illustrate how the volume of the left ventricle may change over a cardiac cycle. As can be seen in FIGS. 7A and 7B, the volume of the left ventricle during ventricular filling is larger than the volume of the left ventricle of the heart during ventricular contraction.

[0087] In some cases, the processing module and/or other control circuitry may capture, at a time point within each of one or more cardiac cycles, a pressure within the heart (e.g. left ventricle), resulting in one or more pressure data points. These one or more data points may be used, in combination with other pressure data points taken at different times during the one or more cardiac cycles, to generate a pressure curve. In some cases, one or more parameters may be extracted or derived from the pressure curve. The pressure curve may be used to facilitate cardiac resynchronization therapy (CRT), patient health status monitoring, and/or the management of a non-CRT cardiac therapy.

[0088] FIG. 8 is a graph **800** showing example pressures and volumes within a heart over time. More specifically, FIG. 8 depicts the aortic pressure, left ventricular pressure, left atrial pressure, left ventricular volume, an electrocardiogram (ECG or egram), and heart sounds of the heart H. A cardiac cycle may begin with diastole, and the mitral valve opens. The ventricular pressure falls below the atrial pressure, resulting in the ventricular filling with blood. During ventricular filling, the aortic pressure slowly decreases as shown. During systole, the ventricle contracts. When ventricular pressure exceeds the atrial pressure, the mitral valve closes, generating the S1 heart sound. Before the aortic valve opens, an isovolumetric contraction phase occurs where the ventricle pressure rapidly increases but the ventricular volume does not significantly change. Once the ventricular pressure equals the aortic pressure, the aortic valve opens and the ejection phase begins where blood is ejected from the left ventricle into the aorta. The ejection phase continues until the ventricular pressure falls below the aortic pressure, at which point the aortic valve closes, generating the S2 heart sound. At this point, the isovolumetric relaxation phase begins and ventricular pressure falls rapidly until it is exceeded by the atrial pressure, at which point the mitral valve opens and the cycle repeats. Cardiac pressure curves for the pulmonary artery, the right atrium,

and the right ventricle, and the cardiac volume curve for the right ventricle, similar to those illustrated in FIG. 8 for the left part of the heart, may be likewise generated. Typically, the cardiac pressure in the right ventricle is lower than the cardiac pressure in the left ventricle.

[0089] In one example, the heart sound signals can be recorded using acoustic sensors, (for example, a microphone), which capture the acoustic waves resulted from heart sounds. In another example, the heart sound signals can be recorded using accelerometers or pressure sensors that capture the accelerations or pressure waves caused by heart sounds. The heart sound signals can be recorded within or outside the heart. These are just examples.

[0090] FIG. 9 is a cross-section of another illustrative implantable leadless cardiac pacemaker (LCP) 900. The LCP 900 may be similar in form and function to the LCPs 100, 610 described above. The LCP 900 may include any of the modules and/or structural features described above with respect to the LCPs 100, 610. The LCP 900 may include a shell or housing 902 having a proximal end 904 and a distal end 906. In the example shown, the LCP 900 does not include a docking member. However, in some cases, a docking member may be provided, such as a cage extending proximally from adjacent the side walls of the housing 902. The illustrative LCP 900 includes a first electrode 908 secured relative to the housing 902 and positioned adjacent to the distal end 906 of the housing 902, and a second electrode (not explicitly shown) secured relative to the housing 902 and positioned adjacent to the proximal end 904 of the housing 902. In some instances, the first electrode 908 may be positioned on a distal end surface facing distally. In some cases, the housing 902 may include a conductive material and may be insulated along a portion of its length. A section along the proximal end 904 may be free of insulation so as to define the second electrode. The electrodes 908 may be sensing and/or pacing electrodes to aid in providing electro-therapy and/or sensing capabilities. The first electrode 908 may be capable of being positioned against or may otherwise contact the cardiac tissue of the heart while the second electrode may be spaced away from the first electrode 908. The first and/or second electrodes 908 may be exposed to the environment outside the housing 902 (e.g. to blood and/or tissue).

[0091] In some cases, the LCP 900 may include a pulse generator (e.g., electrical circuitry) 910 and a power source (e.g., a battery) 912 within the housing 902 to provide and/or receive electrical signals via the first and second electrodes. While not explicitly shown, the LCP 900 may also include a communications module, an electrical sensing module, a mechanical sensing module, and/or a processing module, and associated circuitry, similar in form and function to the modules 102, 106, 108, 110 described above. The various modules and electrical circuitry may be disposed within the housing 902. Electrical communication between the pulse generator and the electrodes may provide electrical stimulation to heart tissue and/or sense a physiological condition.

[0092] In the example shown, the LCP 900 further includes a fixation mechanism 914 proximate the distal end 906 of the housing 902. The fixation mechanism 914 is configured to attach the LCP 900 to a wall of the heart H, or otherwise anchor the LCP 900 to the anatomy of the patient. As shown in FIG. 9, in some instances, the fixation mechanism 914 may include one or more, or a plurality of hooks or tines 916 anchored into the cardiac tissue of the heart H

to attach the LCP 900 to a tissue wall. In other instances, the fixation mechanism 914 may include one or more, or a plurality of passive tines, configured to entangle with trabeculae within the chamber of the heart H and/or a helical fixation anchor configured to be screwed into a tissue wall to anchor the LCP 900 to the heart H. These are just examples.

[0093] Referring now to FIG. 10, which illustrates an enlarged cross-sectional view of the proximal end 904 of the LCP 900. The housing 902 may include a proximal end surface 918 facing proximally (e.g., in a generally opposite direction from the distal end surface). In some instances, the proximal end surface 918 of the housing 902 may form a diaphragm 920. In some cases, the diaphragm 920 may be formed from the housing material itself. When so provided, the wall thickness of the housing in the region of the diaphragm 920 may be thinned to increase the flexibility of the diaphragm 920. In other cases, the diaphragm 920 may be formed from another material, such as but not limited to silicone, polyimides, etc. to form a deformable or movable diaphragm 920 that is responsive to a pressure applied to the diaphragm 920. In any event, the diaphragm 920 may be fabricated to flex or deform as the pressure (external to the housing 902) in the heart (e.g., left ventricle) changes, as will be described in more detail herein. While the entire proximal end surface 918 may form the diaphragm 920, it is contemplated that only a portion of the end surface 918 may form the diaphragm 920. In some cases, the diaphragm 920 may be 1 millimeter in diameter or less. In other cases, the diaphragm 920 may be greater than 1 millimeter in diameter. In some cases, the diaphragm 920 may have a round shape. In other cases, the diaphragm 920 may have a square, rectangular or any other suitable shape. In the example shown, the diaphragm 920 may be configured to transfer an endocardial pressure external to the housing 902 to a pressure sensor 922 positioned within the housing 902.

[0094] As will be described in more detail herein, the diaphragm 920 need not be placed on the proximal end surface 918 of the housing 902. It is contemplated that the diaphragm 920 may be formed in any surface of the housing 902 (or docking member, if so provided) desired. In some cases, locating the diaphragm 920 on or adjacent to the proximal end 904 of the housing 902 may orientate the diaphragm towards the heart valves (when the LCP 900 is positioned in the apex of the heart) and in-line with maximum pressure changes, which may achieve higher signal levels. It may also locate the diaphragm 920 away from the heart tissue, may reduce the likelihood that diaphragm 920 will become fibrossed-over. In some cases, the diaphragm 920 may be coated with an anti-thrombogenic coating to help prevent tissue growth.

[0095] In FIG. 10, a pressure sensor 922 is positioned adjacent to, but not necessarily in direct contact with, the diaphragm 920. When so provided, a fluid filled cavity 926 filled with a fluid 928 may be positioned between the diaphragm 920 of the housing and the pressure sensor 922. In some cases, the pressure sensor 922 may include a diaphragm 934, as best shown in FIG. 11, which is exposed to the fluid filled cavity 926. The fluid filled cavity 926 may communicate a measure related to the pressure applied by the environment (e.g. endocardial pressures) to the diaphragm 920 of the housing 902 to the pressure sensor diaphragm 934 of the pressure sensor 922. In some cases, the fluid filled cavity 926 may be confined to a portion of the

volume of the housing, such as between the flexible diaphragm 920 of the housing and the diaphragm 934 of the pressure sensor 922. An O-ring 923 or other seal may be used to confine the fluid 928. In other instances, the fluid filled cavity 926 may encompass the entire volume of the housing 902 (e.g., the volume not filled by other components).

[0096] It is contemplated that the fluid filled cavity 926 may be filled with an incompressible fluid 928. In some cases, the fluid 928 may also be dielectric or non-conductive. Some illustrative fluids 928 may include, but are not limited to, mineral oil, fluorocarbons perfluorohexane, perfluoro (2-butyl-tetrahydrofurane), perfluorotriethylamine, and/or Fluorinert™ (manufactured by the 3M Company, St. Paul, Minn.). In some cases, the fluid 928 may be highly soluble to gases that are likely to arise inside of the housing, particularly at body temperature (e.g. 37° C.). For example, the fluid 928 may be highly soluble to hydrogen, helium, nitrogen, argon, water, and/or other gases or liquids that might arise inside of the housing as a result of, for example, outgassing of internal components of the LCP 900. As a pressure or external force 930 is applied to the outer surface of the diaphragm 920. In response, the diaphragm 920 may flex inwards and the fluid 928 may transfer the force to the pressure sensor 922, as shown at arrow 932. The pressure sensor 922 may provide a pressure sensor signal that is representative of the pressure or external force 930.

[0097] In some cases, the fluid 928 (and/or the diaphragm 920) may be selected to match the acoustic impedance of blood. This may facilitate the use of the pressure sensor 922 as an acoustic pressure sensor. In some cases, the pressure sensor 922 may be used to detect various sounds such as heart sounds, valve regurgitation, respiration, blood flow, blood turbulence and/or other suitable sounds. In some cases, sounds having a frequency of up to 200 Hz or more may be detected.

[0098] In some cases, the pressure sensor 922 may be a Micro-Electro-Mechanical System (MEMS) pressure sensor, such as shown in FIG. 11. FIG. 11 illustrates a cross-sectional view of an illustrated MEMS pressure sensor. MEMS pressure sensors are often formed by anisotropically etching a recess into a back side of a silicon substrate, leaving a thin flexible diaphragm 934. For an absolute pressure sensor, a sealed cavity 946 is created behind the diaphragm 934. The sealed cavity 946 may be evacuated to a very low pressure, near zero. In operation, the front side of the diaphragm 934 is exposed to an input pressure, such as from the fluid 928, and may flex or deform by an amount that is related to the difference between the input pressure and the vacuum pressure in the sealed cavity 946.

[0099] The diaphragm 934 of the pressure sensor 922 may include one or more sense elements 936, which may detect the flexing of the diaphragm 934. In some cases, the sensor elements may include piezoresistors, the change resistance with increased stress in the diaphragm 934. The piezoresistors may be connected to a circuit, such as a Wheatstone bridge circuit, that outputs a signal that is related to the amount of stress sensed in the diaphragm 934, which is ultimately related to the amount of pressure applied to the outer surface of the diaphragm 920 of the housing. The stress may be one or more of compression or stretching of the diaphragm 920. In some cases, the diaphragm 934 of the pressure sensor 922 and/or the diaphragm 920 of the housing may be made thinner and/or may include one or more

support bosses to help increase the sensitivity and/or linearity of the flexure of the diaphragm.

[0100] In some cases, circuitry 938 may be fabricated in to the first substrate 940, and may be connected to the sensor elements 936. The circuitry 938 may be configured to provide some level of signal processing before providing an output signal to bond pads 948 of the pressure sensor 922. The signal processing circuitry may filter, amplify, linearize, calibrate and/or otherwise process the raw sensor signal produced by the sensor elements (e.g. piezoresistors 936). While the sense elements 936 have been described as piezoresistors, it is contemplated that the sensor elements 936 may be configured to provide a capacitive output value. For example, the back side of the diaphragm 934 may support a first plate of a capacitor sensor, and the top side of the second substrate may support a second plate. As the diaphragm 934 flexes toward the second substrate, the distance between the first plate and the second plate changes. This changes the capacitance between the first plate and the second plate. This change in capacitance can be sensed by circuitry 938.

[0101] The bond pads 948 may be electrically coupled to the circuitry 910 in the housing 902 of the LCP 900 through one or more electrical conductors 924 to relay one or more output signals of the pressure sensor 922 to the circuitry 910. The circuitry 910 may be configured to determine a pressure exterior to the housing 902 based on the pressure sensor 922 output signal(s).

[0102] While the pressure sensor 922 has been described as a MEMS pressure sensor, it is contemplated that pressure sensor 922 may take any suitable form. In one alternative example, the pressure sensor may be formed in such a way that radio waves can be used to detect changes in pressure without sensor elements incorporated into the device. Such a pressure sensor may include a flexible base substrate, a bottom inductive coil positioned on the base substrate, a layer of pressure sensitive rubber pyramids positioned over the bottom inductive coil, a top inductive coil positioned on top of the rubber pyramids, and a top substrate positioned over the top inductive coil. As a pressure is exerted on the sensor, the inductive coils move closer together. Radio waves (from an applied source) reflected by the inductive coils have a lower resonance frequency when the coils are positioned closer together. Thus, the frequency of the radio waves can indicate the distance between the coils, which may then be correlated to the pressure exerted on the device.

[0103] As indicate above, the pressure sensor 922 may be configured to measure absolute pressure, rather than gauge pressure. A communication link may be used to determine atmospheric pressure such that the pressure readings provided to the physician are in terms of gauge pressure. Atmospheric pressure may be measured outside of the patient's body using an external device. The external device may be in communication with the LCP 900 through any of the wireless means described herein. An absolute pressure sensor 922 may provide higher accuracy with lower drift. In some cases, the absolute pressure readings may be transmitted to an external device and converted to gauge pressure at the external device where it can be viewed by a physician and/or transmitted to another external device viewable by the physician.

[0104] In some cases, the diaphragm 920 of the housing 902 may have a first surface area and the pressure sensor diaphragm 934 may have a second surface area. The ratio of

the first surface area to the second surface area may be at least 5 to 1, greater than 10 to 1, greater than 20 to one, or more. In some instances, the pressure sensor 922 may be configured to obtain pressure measurements in the range of 0 to 240 mmHg (gauge) with an accuracy of 1 mmHg and a resolution of less than 1 mmHg. It is contemplated that in some instances, the pressure sensor 922 may be configured to obtain pressure measurements greater than 240 mmHg (for example, when the patient is under extreme exertion). The pressure sensor 922 may be configured to obtain pressure measurements at a sample rate of greater than 100 Hertz (Hz). This may allow for pressure measurements to be used to determine characteristics of the cardiac cycle including, but not limited to, dP/dT, dicrotic notch, etc.

[0105] In some embodiments, one or more sensor elements (e.g. piezoresistors) may be placed directly on the inner surface of the diaphragm 920 of the housing 902 and/or on the housing 902 itself. The sensor elements may then detect the stress in the diaphragm 920 of the housing 902 and/or the housing 902. The sensor elements may be operatively coupled to circuitry (e.g. control electronics 910) through one or more electrical conductors 924. This embodiment may eliminate the need for the fluid filled cavity 926, the fluid 928, the diaphragm 934 of the pressure sensor 922, etc.

[0106] In the example of FIG. 9, the battery 912 is shown adjacent the pressure sensor 922. However, many different configurations of the internal components of the LCP 900 are contemplated. In the example shown, the processing module (e.g., circuitry or control electronics) 910 may be positioned in a distal portion 906 of the housing 902 adjacent to the distal electrode 908. The one or more electrical conductors 924 may be formed of a polyimide or similar interconnect having a cross-sectional dimension in the range of less than 250 microns. It is contemplated that the inside surface of the housing 902 may be electrically insulated and the electrical conductors 924 (e.g., trace) may be positioned on the inside surface of the housing 902 or along the outer surface of the battery 912, as desired. Alternatively, wires or a ribbon cable may be used. These are just examples.

[0107] In some cases, the pressure sensor 922 may be configured to obtain pressure measurements at predetermined intervals over one or more cardiac cycles. In other instances, the pressure sensor may be configured to obtain a pressure measurement in response to a specific cardiac event or at a specific time in a cardiac cycle. For example, the circuitry 910 may be configured to use one or more cardiac signals sensed by the first electrode 908 and/or second electrode to determine when the patient's heart is in a first phase of a cardiac cycle. The circuitry 910 may be configured to determine a pressure exterior to the housing 902 based at least in part on the pressure sensor output signal from the pressure sensor 922 taken during the first phase of the cardiac cycle. In some cases, the first phase may be systole and in other cases the first phase may be diastole. The circuitry 910 may be configured to determine a pressure exterior to the housing 902 based at least in part on the pressure sensor output signal from the pressure sensor 922 taken during the first phase of the cardiac cycle. It is contemplated that the circuitry 910 may be further configured to detect heart sounds of the patient's heart based at least in part on the pressure sensor output signal. For example, the first heart sound may be a timing fiducial for

a sudden increase in pressure while the second heart sound may be a timing fiducial for a sudden decrease in pressure.

[0108] In some cases, the circuitry 910 and/or pressure sensor 922 of the LCP 900 may be configured to obtain a plurality of pressure readings over one or more cardiac cycles. The pressure readings may be plotted (either by the circuitry 910 or an external device) to form a graph similar to the one shown in FIG. 8. Various parameters related to the function of the heart can be extrapolated from the graph including but not limited to peak to peak measurements, dP/dT, time averaged values, inotropic response of the ventricle, etc. In some instances, the pressure measurements may be compared to calibration values (e.g., measurements taken at the time of implantation of the LCP 900).

[0109] In some cases, a diaphragm 920 having a different material may not be provided. In other words, the diaphragm 920 may be formed of the same material and of the same thickness as the remaining portion of the housing 902. For example, the housing 902 may flex or deform to transfer a pressure external to the housing 902 to the pressure sensor 922 located within the housing 612. For example, the housing 902 may have a compliance such that the relative movement of the housing 902 in response to the external pressure may be coupled to the internal pressure sensor 922. The internal pressure sensor 922 may be calibrated relative to external pressures prior to implantation of the LCP 902 in a patient. The calibration data may be stored in the memory and/or electrical circuitry of the LCP 900. For example, once the LCP 900 is implanted, a measure related to the pressure applied by the environment (e.g. endocardial pressures) to the housing 902 may be communicated to a pressure sensing diaphragm 934 of the pressure sensor 922. It is contemplated that there may be some pressure loss (e.g., in the range of 1-20%) between the pressure exerted on the housing 902 and the pressure reading obtained at the pressure sensor 922. This pressure loss may be compensated for (e.g., nullified) by adjusting the pressure sensor signal from the pressure sensor 922 using the calibration data stored in the LCP 900. It is contemplated that an incompressible fluid may couple the housing 902 and the pressure sensing diaphragm 934 of the pressure sensor 922 in a manner similar to that described herein. For example, the entire housing 902 or a portion of the housing 902 may be coupled to the pressure sensor 922 by the incompressible fluid.

[0110] FIG. 12 illustrates a proximal end portion 954 of another illustrative LCP 950 having a diaphragm 960 and a pressure sensor 962. The LCP 950 may be similar in form and function to the LCPs 100, 610, 900 described above. The LCP 950 may include any of the modules and/or structural features described above with respect to the LCPs 100, 610, 900. The diaphragm 960, pressure sensor 962 and internal circuitry (not explicitly shown) may interact in a similar manner to the diaphragm 920, pressure sensor 922 and circuitry 910 described above.

[0111] The LCP 950 may include a shell or housing 952 having a proximal end portion 954 and a distal end (not explicitly shown). The housing 952 may include a proximal end surface 956 facing proximally (e.g., in a generally opposite direction from the distal end surface). In some instances, the proximal end surface 956 of the housing 952 may include a region of localized thinning 958. For example, the housing 952 may have a first wall thickness T1 and the region of localized thinning 958 may have a second wall thickness T2. The second wall thickness T2 may be less

than the first wall thickness **T1**. In some embodiments, the region of localized thinning **958** may have a thickness **T2** in the range of 30 microns. This is just an example. The region of localized thinning **958** may have a thickness such that the region **958** may be deformable or movable to create a diaphragm **960** that is responsive to a pressure applied to the proximal end surface **956**. This may allow the diaphragm **960** to flex or deform as the pressure (external to the housing **952**) in the heart (e.g., left ventricle) changes, as will be described in more detail herein.

[0112] In some cases, the region of localized thinning **958** may be created by removing material from the housing **952** from an interior of the housing **952**, which may reduce nucleation points for thrombus formation. The region of localized thinning **958** may transition from the first wall thickness **T1** to the second wall thickness **T2** in a tapered, sloped, or curved (e.g., exponential) manner. In other words, the region of localized thinning **158** may not have a uniform thickness across its width. A sloped transition between the first wall thickness **T1** and the second wall thickness **T2** may help reduce stress concentration and/or non-linearity in the proximal end surface **956**. However, in some cases, the region of localized thinning **958** may transition from the first wall thickness **T1** to the second wall thickness **T2** in an abrupt or step-wise manner. In other words, the region of localized thinning **158** may have a uniform thickness across its width (not explicitly shown). The region of localized thinning **958** may function as a diaphragm **960** formed by the housing **952**. In some cases, the diaphragm **960** may be as small as approximately 1 millimeter in diameter. The diaphragm **960** diameter and thickness may be configured so that the diaphragm **960** is able to suitably transfer a pressure external to the housing **952** (e.g. an endocardial pressure) to a pressure sensor **962** positioned within the housing **952**, via a cavity **968** filled with a fluid **970**. An O-ring **963** or other seal may be used to confine the fluid **970**. In other instances, the fluid filled cavity **970** may encompass the entire volume of the housing **952** (e.g., the volume not filled by other components) distal of the diaphragm **960**.

[0113] FIG. 13 illustrates a cross-sectional view of a proximal end portion **1004** of another illustrative LCP **1000** having a diaphragm **1006** and a force sensor **1010**. The LCP **1000** may be similar in form and function to the LCPs **100**, **610**, **900** described above. The LCP **1000** may include any of the modules and/or structural features described above with respect to the LCPs **100**, **610**, **900**. The diaphragm **1006**, a force sensor **1010** and internal circuitry (not explicitly shown) may interact in a similar manner to the diaphragm **920**, pressure sensor **922** and circuitry **910** described above.

[0114] The LCP **1000** may include a shell or housing **1002** having a proximal end portion **1004** and a distal end (not explicitly shown). The housing **1002** may include a proximal end surface **1006** facing proximally (e.g., in a generally opposite direction from the distal end surface). The proximal end surface **1006** may include a pair of generally opposing sidewalls **1014a**, **1014b** (collectively, **1014**) extending distally therefrom. In this example, the sidewalls **1014** may include a crumple-zone **1008a**, **1008b** (collectively, **1008**) formed therein. The crumple-zones **1008** may have an accordion or bellow-like structure including a plurality of peaks **1022a**, **1022b** (collectively, **1022**) and valleys **1024a**, **1024b** (collectively, **1024**) which allows the crumple-zones **1008** to compress in the distal direction **1016** or elongate in

the proximal direction **1018**. This may allow the internal volume of the housing **1002** to change as an exteriorly applied pressure **1020** is applied to the housing **1002**. While the peaks **1022** and valleys **1024** are illustrated as having sharp or abrupt edges, the peaks **1022** and valleys **1024** may have gentle slopes or curves as desired.

[0115] A strut **1021** may extend from the proximal end surface **1006** to the force sensor **1010**. The force sensor **1010** may sense the force that is applied by the strut **1021**. The strut **1021** may transfer the force that is applied to the proximal end surface **1006** of the housing by an external pressure (e.g. endocardial pressure). The force applied to the proximal end surface **1006** of the housing by an external pressure (e.g. endocardial pressure) is amplified by the ratio of the surface area of the proximal end surface **1006** to the surface area of the strut that abuts the force sensor **1010**.

[0116] The force sensor **1010** may be operatively coupled to circuitry or control electronics (not explicitly shown) of the LCP **1000** through one or more electrical connections **1026**. FIG. 13 illustrates the battery **1028** adjacent to the force sensor **1010**. However, many different configurations of the internal components are contemplated. The one or more electrical connections **1026** may be formed of a polyimide or similar interconnect having a cross-sectional dimension in the range of less than **250** microns. It is contemplated that the inside surface of the housing **1002** may be electrically insulated and the electrical connection **1026** (e.g., trace) positioned on the inside surface of the housing **1002** or along the outer surface of the battery **1028**, as desired. Alternatively, wires or a ribbon cable may be used. These are just examples.

[0117] FIG. 14 illustrates a cross-sectional view of a proximal end portion **1054** of another illustrative LCP **1050** having a diaphragm **1058** and a pressure sensor **1060**. The LCP **1050** may be similar in form and function to the LCPs **100**, **610**, **900** described above. The LCP **1050** may include any of the modules and/or structural features described above with respect to the LCPs **100**, **610**, **900**. The diaphragm **1058**, pressure sensor **1060** and internal circuitry (not explicitly shown) may interact in a similar manner to the diaphragm **920**, pressure sensor **922** and circuitry **910** described above.

[0118] The LCP **1050** may include a shell or housing **1052** having a proximal end portion **1054** and a distal end (not explicitly shown). The housing **1052** may include a docking member **1056** extending proximally from the proximal end portion **1054**. The docking member **1056** may be configured to facilitate delivery and/or retrieval of the LCP **1050**. For example, the docking member **1056** may extend from the proximal end portion **1054** of the housing **1052** along a longitudinal axis of the housing **1052**. The docking member **1056** may include a head portion **1062** and a neck portion **1064** extending between the housing **1052** and the head portion **1062**. The head portion **1062** may be an enlarged portion relative to the neck portion **1064**. An access port **1068** may extend through the head portion **1062** and the neck portion **1064** to fluidly couple the diaphragm **1058** with the blood in the heart. The diaphragm **1058** may be constructed using any of the materials and/or configurations described herein. Alternatively, the diaphragm **1058** may be positioned at the proximal opening **1070** of the access port **1068**.

[0119] A pressure sensor **1060** may be positioned adjacent to, but not necessarily in direct contact with the diaphragm

1058. The pressure sensor **1060** may be operatively coupled to circuitry or control electronics (not explicitly shown) of the LCP **1050** through one or more electrical connections **1072**. FIG. **14** illustrates the battery **1078** adjacent to the pressure sensor **1060**. However, many different configurations of the internal components of the LCP **1050** are contemplated. The one or more electrical connections **1072** may be formed of a polyimide or similar interconnect having a cross-sectional dimension in the range of less than 250 microns. It is contemplated that the inside surface of the housing **1052** may be electrically insulated and the electrical connection **1072** (e.g., trace) positioned on the inside surface of the housing **1052** or along the outer surface of the battery **1078**, as desired. Alternatively, wires or a ribbon cable may be used. These are just examples.

[**10120**] The pressure sensor **1060** may be positioned in or adjacent to a cavity **1074** filled with a fluid **1076**. The fluid filled cavity **1074** is in fluid communication with the diaphragm **1058** and the pressure sensor **1060**, such that the fluid filled cavity **1074** may communicate a measure related to the pressure applied by the environment to the diaphragm **1058** to a pressure sensor diaphragm of the pressure sensor **1060**. In some cases, the fluid filled cavity **1074** may be confined to a portion of the volume of the housing **1052**, such as between the flexible diaphragm **1058** and a sensor diaphragm (not shown) of the pressure sensor **1060**. An O-ring **1073** or other seal may be used to confine the fluid **1076**. In other instances, the fluid filled cavity **1074** may encompass the entire volume of the housing **1052** (e.g., the volume not filled by other components) distal of the diaphragm **1058**. In the example shown in FIG. **14**, the diaphragm **1058** is located distal of the docking member **1056**. An access port **1068** is provided through the docking member **1056** so allow endocardial pressure **1080** to engage the diaphragm **1058**.

[**10121**] In some cases, a plurality of access ports **1108a-1108d** may be provided to the diaphragm **1058**, such as shown in FIG. **15**. FIG. **15** illustrates a proximal end view of another illustrative LCP **1100** having a diaphragm and an internally positioned pressure sensor (not explicitly shown). The LCP **1100** may be similar in form and function to the LCP **1050** described above. The LCP **1100** may include any of the modules and/or structural features described above with respect to the LCPs **100**, **610**, **900**, **1050**. A diaphragm, pressure sensor and internal circuitry (not explicitly shown in FIG. **11**) may interact in a similar manner to the diaphragm **1058**, pressure sensor **1060** and circuitry of FIG. **14**.

[**10122**] The LCP **1100** may include a shell or housing having a proximal end region **1104** and a distal end (not explicitly shown). The housing **1102** may include a docking member **1106** extending proximally from the proximal end region **1104**. The docking member **1106** may be configured to facilitate delivery and/or retrieval of the LCP **1100**. For example, the docking member **1106** may extend from the proximal end region **1104** of the housing **1102** along a longitudinal axis of the housing **1102**. One or more access ports **1108a**, **1108b**, **1108c**, **1108d** (collectively, **1108**) may be formed through the docking member **1106** and/or through the proximal end region **1104** of the housing **1102**. It is contemplated that the access ports **1108** may allow endocardial pressure **1080** to engage the diaphragm inside of the housing, similar to that shown and described with respect to FIG. **14**.

[**10123**] FIG. **16** is a side view of another illustrative implantable leadless cardiac pacemaker (LCP) **1150**. The LCP **1150** may be similar in form and function to the LCPs **100**, **610**, **900** described above. The LCP **1150** may include any of the modules and/or structural features described above with respect to the LCPs **100**, **610**, **900**. The LCP **1150** may include a shell or housing **1152** having a proximal end **1154** and a distal end **1156**. In the example shown, the LCP **1150** does not include a docking member. However, in some cases, a docking member may be provided at the proximal end **1154** of the LCP **1150**. The illustrative LCP **1150** includes a first electrode **1158** secured relative to the housing **1152** and positioned adjacent to the distal end **1156** of the housing **1152**, and a second electrode **1160** secured relative to the housing **1152** and positioned adjacent to the proximal end **1154** of the housing **1152**. In some instances, the first electrode **1158** may be positioned on a distal end surface facing distally. In some cases, the housing **1152** may include a conductive material and may be insulated along a portion of its length. A section along the proximal end **1154** may be free of insulation so as to define the second electrode. The electrodes **1158**, **1160** may be sensing and/or pacing electrodes to provide electro-therapy and/or sensing capabilities. The first electrode **1158** may be capable of being positioned against or may otherwise contact the cardiac tissue of the heart while the second electrode may be spaced away from the first electrode **1158**. The first and/or second electrodes **1158**, **1160** may be exposed to the environment outside the housing **1152** (e.g. to blood and/or tissue).

[**10124**] In some cases, the LCP **1150** may include a pulse generator (e.g., electrical circuitry) and a power source (e.g., a battery) within the housing **1152** to provide electrical signals to the electrodes **1158**, **1160** to control the pacing/sensing electrodes **1158**, **1160**. While not explicitly shown, the LCP **1150** may also include a communications module, an electrical sensing module, a mechanical sensing module, and/or a processing module, and the associated circuitry, similar in form and function to the modules **102**, **106**, **108**, **110** described above. The various modules and electrical circuitry may be disposed within the housing **1152**.

[**10125**] In the example shown, the LCP **1150** includes a fixation mechanism **1162** proximate the distal end **1156** of the housing **1152**. The fixation mechanism **1162** is configured to attach the LCP **1150** to a wall of the heart, or otherwise anchor the LCP **1150** to the anatomy of the patient. As shown in FIG. **16**, in some instances, the fixation mechanism **1162** may include one or more, or a plurality of hooks or tines **1164** anchored into the cardiac tissue of the heart to attach the LCP **1150** to a tissue wall. In other instances, the fixation mechanism **1162** may include one or more, or a plurality of passive tines, configured to entangle with trabeculae within the chamber of the heart and/or a helical fixation anchor configured to be screwed into a tissue wall to anchor the LCP **1150** to the heart. These are just examples.

[**10126**] The housing **1152** may include a plurality of pressure sensitive regions or diaphragms **1166a**, **1166b** (collectively, **1166**). While the example shown in FIG. **16** illustrates two diaphragms **1166**, the LCP **1150** may include any number of diaphragms **1166** desired such as, but not limited to, one, two, three, four, or more. It is further contemplated that the diaphragms **1166** may be uniformly or eccentrically positioned about the circumference of the housing **1152**. In some cases, the diaphragms **1166** may be spaced equally

about the entire circumference of the housing 1152, while in other cases, the diaphragms 1166 may be positioned about a portion of the circumference of the housing 1152. In some embodiments, the diaphragms 1166 may be formed from a flexible or compliant material, such as, but not limited to silicone, polyimides, etc. to form a deformable or movable diaphragm 1166 that is responsive to a pressure applied to the diaphragm 1166. In other cases, the diaphragms 1166 may be formed from a thinned wall of the housing itself. In either case, this may allow the diaphragms 1166 to flex or deform as the pressure (external to the housing 1152) in the heart (e.g., left ventricle) changes, as will be described in more detail herein. Alternatively, the diaphragms 1166 may be a combination of flexible materials and/or regions of localized thinning, and/or any other suitable configuration. While the diaphragms 1166 are illustrated as positioned adjacent to the proximal end 1154, it is contemplated that the diaphragms 1166 may be positioned anywhere along the length of the LCP 1150 as desired.

[0127] In some cases, locating the diaphragms 1166 on or adjacent to the proximal end 1154 of the housing 1152 may orientate the diaphragm towards the heart valves (when the LCP 1150 is positioned in the apex of the heart), which may achieve higher levels of sensitivity. Locating the diaphragm 1166 further away from the heart tissue may also reduce the likelihood of the diaphragm becoming fibrosed-over. However, the diaphragm 1166 may be coated with an anti-thrombogenic coating to help reduce such tissue growth.

[0128] One or more pressure sensors may be positioned adjacent to, but not necessarily in direct contact with, the diaphragms 1166. In some embodiments, piezoresistors may be placed directly on the inner surface of the diaphragms 1166. The pressure sensor may be operatively coupled to the circuitry or control electronics of the LCP 1050 through one or more electrical connections. The one or more electrical connections may be formed of a polyimide or similar interconnect having a cross-sectional dimension in the range of less than 250 microns. It is contemplated that the inside surface of the housing 1152 may be electrically insulated and the electrical connection (e.g., trace) positioned on the inside surface of the housing 1152 or along the outer surface of the battery, as desired. Alternatively, wires or a ribbon cable may be used. These are just examples.

[0129] The one or more pressure sensors may be positioned in or adjacent to one or more cavities filled with a fluid. The one or more fluid filled cavities may be in fluid communication with the diaphragms 1166 and the one or more pressure sensors such that the one or more fluid filled cavities may communicate a measure related to the pressure applied by the environment to the diaphragms 1166 of the housing 1152 to a pressure sensor diaphragm of a corresponding pressure sensor. In some instances, a fluid filled cavity may encompass the entire volume of the housing 1152 (e.g., the volume not filled with other components). In other embodiments, the one or more fluid filled cavities may be a portion of the volume of the housing between the flexible diaphragms 1166 and the pressure sensor. In some cases, each of the diaphragms 1166 has a corresponding pressure sensor, such that a separate pressure signal can be derived for each of the diaphragms 1166. When so provided, pressures at different locations of the housing may be detected. In some cases, these different pressures can be used to detect a variety of different conditions including, for example, blood flow around the housing, pressure waves as

they pass over the housing, relative direction of a detected heart sound using the relative locations of the diaphragms 1166 and the delay between detection times. These are just examples.

[0130] FIG. 17A is a partial cross-sectional view of another illustrative implantable leadless cardiac pacemaker (LCP) 1200. The LCP 1200 may be similar in form and function to the LCPs 100, 610, 900 described above. The LCP 1200 may include any of the modules and/or structural features described above with respect to the LCPs 100, 610, 900. The LCP 1200 may include a shell or housing 1202 having a proximal end region 1204 and a distal end 1206. The housing 1202 may include a docking member 1210 extending proximally from the proximal end region 1204. The docking member 1210 may be configured to facilitate delivery and/or retrieval of the LCP 1200. For example, the docking member 1210 may extend from the proximal end region 1204 of the housing 1202 along a longitudinal axis of the housing 1202.

[0131] The illustrative LCP 1200 includes a first electrode 1208 secured relative to the housing 1202 and positioned adjacent to the distal end 1206 of the housing 1202, and a second electrode (not explicitly shown) secured relative to the housing 1202 and positioned adjacent to the proximal end region 1204 of the housing 1202. In some instances, the first electrode 1208 may be positioned on a distal end surface facing distally. In some cases, the housing 1202 may include a conductive material and may be insulated along a portion of its length. A section along the proximal end region 1204 may be free of insulation so as to define the second electrode. The electrodes 1208 may be sensing and/or pacing electrodes to provide electro-therapy and/or sensing capabilities. The first electrode 1208 may be capable of being positioned against or may otherwise contact the cardiac tissue of the heart while the second electrode may be spaced away from the first electrode 1208. The first and/or second electrodes 1208 may be exposed to the environment outside the housing 1202 (e.g. to blood and/or tissue).

[0132] In some cases, the LCP 1200 may include a pulse generator 1218 (e.g., electrical circuitry) and a power source 1220 (e.g., a battery) within the housing 1202 to provide electrical signals to the electrodes 1208 to control the pacing/sensing electrodes 1208. The LCP 1200 may also include a communications module 1222, an electrical sensing module 1224, a mechanical sensing module 1226, and/or a processing module 1228, and the associated circuitry, similar in form and function to the modules 102, 106, 108, 110 described above. The various modules and electrical circuitry may be disposed within the housing 1202. The modules 1218, 1222, 1224, 1226, 1228 may be positioned on a flexible board (e.g., a flexible polyimide) 1232, which allows for electrical communication between the various modules. In some cases, the flexible board 1232 may be folded over to allow for different size components and/or more components to be present. In order to accommodate the flexible board 1232, the battery 1220 may have a generally "D" shaped cross-section. This is better illustrated in FIG. 17B which illustrates a cross-section of the LCP 1200 taken at line B-B of FIG. 17A.

[0133] In the example shown, the LCP 1200 includes a fixation mechanism 1212 proximate the distal end 1206 of the housing 1202. The fixation mechanism 1212 is configured to attach the LCP 1200 to a wall of the heart H, or otherwise anchor the LCP 1200 to the anatomy of the

patient. As shown in FIG. 16, in some instances, the fixation mechanism 1212 may include one or more, or a plurality of hooks or tines 1214 anchored into the cardiac tissue of the heart to attach the LCP 1200 to a tissue wall. In other instances, the fixation mechanism 1212 may include one or more, or a plurality of passive tines, configured to entangle with trabeculae within the chamber of the heart and/or a helical fixation anchor configured to be screwed into a tissue wall to anchor the LCP 1200 to the heart. These are just examples.

[0134] The housing 1202 may include one or more pressure sensitive regions or diaphragms (not explicitly shown). The diaphragm may be positioned in the proximal end surface 1234 of the housing 1202, in the docking member 1210, and/or in the side wall of the housing 1202 as desired. In some cases, all or a majority of the housing may function as a diaphragm. When so provided, the housing may have a wall thickness that will flex under endocardial pressures. In some cases, the entire housing may be filled with an incompressible and non-conductive fluid.

[0135] A pressure sensor 1230 may be positioned adjacent to, but not necessarily in direct contact with, the diaphragm (s). In some embodiments, a piezoresistors may be placed directly on the inner surface of the diaphragm(s). The pressure sensor 1230 may be operatively coupled to the circuitry or control electronics through one or more electrical connections (e.g., flexible board 1232). The pressure sensor 1230 may be positioned in or adjacent to a cavity 1236 filled with a fluid 1238. The fluid filled cavity 1236 is in fluid communication with the diaphragm(s) and the pressure sensor 1230 such that the fluid filled cavity 1236 may communicate a measure related to the pressure applied by the environment to the diaphragm(s) of the housing 1202 to a pressure sensor diaphragm of the pressure sensor 1230. As noted above, and in some instances, the fluid filled cavity 1236 may encompass the entire volume of the housing 1202 (e.g., the volume not filled with other components). In other embodiments, the fluid filled cavity 1236 may be a portion of the volume of the housing, and may extend between the flexible diaphragm and the pressure sensor 1230. The fluid filled cavity 1236 may be filled with an incompressible fluid 1238. In some cases, the fluid filled cavity 1236 may be filled with a non-conductive fluid 1238. In some cases, the fluid 1238 may be highly soluble to gases that are likely to arise inside of the housing, particularly at body temperature (e.g. 37° C.). For example, the fluid 1238 may be highly soluble to hydrogen, helium, nitrogen, argon, water, and/or other gases or liquids that might arise inside of the housing as a result of, for example, outgassing of internal components of the LCP 1200.

[0136] In some cases, the fluid 1238 (and/or the diaphragm material) may be selected to match the acoustic impedance of blood. This may facilitate the use of the pressure sensor 1230 as an acoustic pressure sensor. In some cases, the pressure sensor 1230 may be used to detect various sounds such as heart sounds, valve regurgitation, respiration, blood flow, blood turbulence and/or other suitable sounds. In some cases, sounds having a frequency of up to 200 Hz or more may be detected.

[0137] A pressure exterior to the housing 1202 may be communicated to the pressure sensor diaphragm of the pressure sensor 1230 through the fluid 1238. For example, as the diaphragm of the housing 1202 deflects inward, the incompressible fluid 1238 may transfer or communicate the

pressure exterior to the housing 1202 to the pressure sensor diaphragm of the pressure sensor 1230. The pressure sensor 1230 may use the deflection of the pressure sensor diaphragm to determine an output signal related to the pressure exterior to the housing 1202. The pressure sensor output signal may be communicated to the circuitry 1218, 1222, 1224, 1226, and/or 1228 in the housing 1202 through one or more electrical connections. The circuitry is configured to determine a pressure exterior to the housing 1202 based on the pressure sensor output signal.

[0138] FIG. 18 is a partial cross-sectional a side view of another illustrative implantable leadless cardiac pacemaker (LCP) 1250. The LCP 1250 may be similar in form and function to the LCPs 100, 610, 900 described above. The LCP 1250 may include any of the modules and/or structural features described above with respect to the LCPs 100, 610, 900. The LCP 1250 may include a shell or housing 1252 having a proximal end region 1254 and a distal end 1256. The housing 1252 may include a docking member 1260 extending proximally from the proximal end region 1254. The docking member 1260 may be configured to facilitate delivery and/or retrieval of the LCP 1250. For example, the docking member 1260 may extend from the proximal end region 1254 of the housing 1252 along a longitudinal axis of the housing 1252.

[0139] The illustrative LCP 1250 includes a first electrode 1258 secured relative to the housing 1252 and positioned adjacent to the distal end 1256 of the housing 1252 and a second electrode (not explicitly shown) secured relative to the housing 1252 and positioned adjacent to the proximal end region 1254 of the housing 1252. In some instances, the first electrode 1258 may be positioned on a distal end surface facing distally. In some cases, the housing 1252 may include a conductive material and may be insulated along a portion of its length. A section along the proximal end region 1254 may be free of insulation so as to define the second electrode. The electrodes 1258 may be sensing and/or pacing electrodes to provide electro-therapy and/or sensing capabilities. The first electrode 1258 may be capable of being positioned against or may otherwise contact the cardiac tissue of the heart while the second electrode may be spaced away from the first electrode 1258. The first and/or second electrodes 1258 may be exposed to the environment outside the housing 1252 (e.g. to blood and/or tissue).

[0140] In the example shown, the LCP 1250 includes a fixation mechanism 1262 proximate the distal end 1256 of the housing 1252. The fixation mechanism 1262 is configured to attach the LCP 1250 to a wall of the heart H, or otherwise anchor the LCP 1250 to the anatomy of the patient. As shown in FIG. 18, in some instances, the fixation mechanism 1262 may include one or more, or a plurality of hooks or tines 1264 anchored into the cardiac tissue of the heart to attach the LCP 1250 to a tissue wall. In other instances, the fixation mechanism 1262 may include one or more, or a plurality of passive tines, configured to entangle with trabeculae within the chamber of the heart and/or a helical fixation anchor configured to be screwed into a tissue wall to anchor the LCP 1250 to the heart. These are just examples.

[0141] In some cases, the LCP 1250 may include a pulse generator 1268 (e.g., electrical circuitry) and a power source 1270 (e.g., a battery) within the housing 1252 to provide electrical signals to the electrodes 1258 to control the pacing/sensing electrodes 1258. The LCP 1250 may also

include other modules **1272** including but not limited to a communications module, an electrical sensing module, a mechanical sensing module, and/or a processing module, and the associated circuitry, similar in form and function to the modules **102**, **106**, **108**, **110** described above. The various modules and electrical circuitry may be disposed within the housing **1252**. The modules **1268**, **1272**, may be positioned on a flexible board (e.g., a flexible polyimide) **1274** which allows for electrical communication between the various modules. In some cases, the flexible board **1274** may be folded over to allow for different size components and/or more components to be present. In order to minimize the feed thru and wiring requirements, the modules **1268**, **1272** may be positioned adjacent to the distal end **1256** of the LCP **1250**.

[0142] The housing **1252** may include one or more pressure sensitive regions or diaphragms (not explicitly shown). The diaphragm may be positioned in the proximal end surface of the housing **1252**, in the docking member **1260**, and/or in the side wall of the housing **1252** as desired. The diaphragm may be formed of any of the various materials and/or configurations described herein.

[0143] A pressure sensor **1276** may be positioned adjacent to, but not necessarily in direct contact with, the diaphragms. The pressure sensor **1276** may be operatively coupled to the circuitry or control electronics through one or more electrical connections (e.g., flexible board **1274**). In some cases, the pressure sensor **1276** may be positioned in the distal end **1256** of the LCP **1250** in or adjacent to a cavity **1278** filled with a fluid **1280**. The fluid filled cavity **1278** is in fluid communication with the diaphragm and the pressure sensor **1276** such that the fluid filled cavity **1278** may communicate a measure related to the pressure applied by the environment to the diaphragm of the housing **1252** to a pressure sensor diaphragm of the pressure sensor **1276**. In some embodiments, the battery **1270** may include a port or lumen **1282** extending therethrough. This may allow the pressure sensor **1276** to be positioned in the distal end **1256** of the LCP **1250** while allowing the diaphragm(s) to be positioned adjacent to the proximal end region **1254**. A fluid passage **1282** provides a fluid pathway to allow the diaphragm of the housing **1252** to be in fluid communication with the pressure sensor diaphragm. The port **1282** may extend through the center of the battery **1270** as shown. Rather than providing the port **1282**, it is contemplated that the fluid filled cavity **1278** may encompass the entire volume of the housing **1252** (e.g., the volume not filled with other components).

[0144] A pressure exterior to the housing **1252** may be communicated to the pressure sensor diaphragm through the fluid **1280**. For example, as the diaphragm of the housing **1252** deflects inward, an incompressible fluid **1280** may transfer or communicate the pressure exterior to the housing **1252** to the pressure sensor diaphragm, sometimes via fluid in the port **1282**. The pressure sensor **1276** may use the deflection of the pressure sensor diaphragm to determine an output signal related to the pressure exterior to the housing **1252**. The pressure sensor output signal may be communicated to the circuitry **1268**, **1272**, in the housing **1252** through one or more electrical connections. The circuitry is configured to determine a pressure exterior to the housing **1252** based on the pressure sensor output signal.

[0145] Those skilled in the art will recognize that the present disclosure may be manifested in a variety of forms other than the specific examples described and contemplated

herein. For instance, as described herein, various examples include one or more modules described as performing various functions. However, other examples may include additional modules that split the described functions up over more modules than that described herein. Additionally, other examples may consolidate the described functions into fewer modules. Accordingly, departure in form and detail may be made without departing from the scope and spirit of the present disclosure as described in the appended claims.

What is claimed is:

1. A leadless cardiac pacemaker (LCP) configured to sense cardiac activity and to pace a patient's heart, the LCP comprising:

- a housing having a proximal end and a distal end;
- a first electrode secured relative to the housing and exposed to the environment outside of the housing;
- a second electrode secured relative to the housing and exposed to the environment outside of the housing;
- the housing having a diaphragm that is exposed to the environment outside of the housing, the diaphragm is responsive to a pressure applied to the diaphragm by the environment outside of the housing;
- a pressure sensor within the housing, the pressure sensor having a pressure sensor diaphragm that is responsive to a pressure applied to the pressure sensor diaphragm and provides a pressure sensor output signal that is representative of the pressure applied to the pressure sensor diaphragm;
- a fluid filled cavity in fluid communication with both the diaphragm of the housing and the pressure sensor diaphragm of the pressure sensor, the fluid filled cavity is configured to communicate a measure related to the pressure applied by the environment to the diaphragm of the housing to the pressure sensor diaphragm of the pressure sensor; and
- circuitry in the housing in operative communication with the pressure sensor, the circuitry configured to determine a pressure exterior to the housing based on the pressure sensor output signal.

2. The LCP of claim 1, wherein the circuitry is further operatively coupled to the first electrode and the second electrode, and is further configured to:

- use one or more cardiac signals sensed by the first electrode and the second electrode to determine when the patient's heart is in a first phase of a cardiac cycle; and
- determine a pressure exterior to the housing based at least in part on the pressure sensor output signal taken during the first phase of a cardiac cycle.

3. The LCP of claim 2, wherein the first phase of a cardiac cycle is systole.

4. The LCP of claim 2, wherein the first phase of a cardiac cycle is diastole.

5. The LCP of claim 1, wherein the circuitry is configured to detect heart sounds of the patient's heart based at least in part on the pressure sensor output signal.

6. The LCP of claim 1, wherein the diaphragm of the housing comprises a localized thinning of a housing wall of the housing.

7. The LCP of claim 1, wherein the diaphragm of the housing comprises a region comprising a compliant material.

8. The LCP of claim 1, wherein the diaphragm of the housing comprises one or more bellows.

9. The LCP of claim 1, further comprising a fixation member at the distal end of the housing for fixing the distal end of the housing to the patient's heart, and wherein the diaphragm of the housing is adjacent the proximal end of the housing.

10. The LCP of claim 1, wherein the housing includes an elongated body with a distal end surface facing distally and a proximal end surface facing proximally, wherein the diaphragm of the housing is situated on the proximal end surface of the housing.

11. The LCP of claim 1, wherein the housing has a plurality of diaphragms that are exposed to the environment outside of the housing, each of the plurality of diaphragms are responsive to the pressure applied to the corresponding diaphragm by the environment outside of the housing.

12. The LCP of claim 1, wherein the fluid filled cavity is filled with an incompressible fluid.

13. The LCP of claim 12, wherein the incompressible fluid is a dielectric fluid.

14. The LCP of claim 1, further comprising an anti-thrombogenic coating disposed over the diaphragm of the housing.

15. The LCP of claim 1, wherein the diaphragm of the housing has a first surface area and the pressure sensor diaphragm of the pressure sensor has a second surface area, wherein a ratio of the first surface area to the second surface area is at least 5 to 1.

16. A leadless cardiac pacemaker (LCP) configured to sense cardiac activity and to pace a patient's heart, the LCP comprising:

- a housing having a proximal end and a distal end;
- a first electrode secured relative to the housing and exposed to the environment outside of the housing;
- a second electrode secured relative to the housing and exposed to the environment outside of the housing;
- the housing having a diaphragm that is exposed to the environment outside of the housing, the diaphragm is responsive to a pressure applied to the diaphragm by the environment outside of the housing;
- one or more sensors coupled to the diaphragm of the housing for detecting a stress in the diaphragm of the housing, wherein the stress in the diaphragm is representative of the pressure applied to the diaphragm by the environment outside of the housing; and

circuitry in the housing in operative communication with the one or more sensors for determining a pressure exterior to the housing based at least in part on the detected stress in the diaphragm of the housing.

17. The LCP of claim 16, wherein the diaphragm of the housing comprises a localized thinning of a housing wall of the housing.

18. The LCP of claim 17, wherein the localized thinning of the housing wall comprises a transition from a first thicker wall thickness to a second thinner wall thickness.

19. The LCP of claim 16, wherein the one or more sensors comprises a piezo resistor, and wherein the stress in the diaphragm comprises one or more of compression and stretching.

20. An implantable medical device (IMD) comprising:

- a housing having a proximal end and a distal end;
- a first electrode secured relative to the housing and exposed to the environment outside of the housing;
- a second electrode secured relative to the housing and exposed to the environment outside of the housing;
- the housing having a diaphragm that is exposed to the environment outside of the housing, the diaphragm is responsive to a pressure applied to the diaphragm by the environment outside of the housing;
- a pressure sensor within the housing, the pressure sensor having a pressure sensor diaphragm that is responsive to a pressure applied to the pressure sensor diaphragm and provides a pressure sensor output signal that is representative of the pressure applied to the pressure sensor diaphragm;
- a fluid filled cavity in fluid communication with both the diaphragm of the housing and the pressure sensor diaphragm of the pressure sensor, the fluid filled cavity is configured to communicate a measure related to the pressure applied by the environment to the diaphragm of the housing to the pressure sensor diaphragm of the pressure sensor; and
- circuitry in the housing in operative communication with the pressure sensor, the circuitry configured to determine a pressure exterior to the housing based on the pressure sensor output signal, and further configured to communicate with another device via the first and second electrodes.

* * * * *

专利名称(译)	带压力传感器的植入式医疗设备		
公开(公告)号	US20180117341A1	公开(公告)日	2018-05-03
申请号	US15/791311	申请日	2017-10-23
[标]申请(专利权)人(译)	心脏起搏器股份公司		
申请(专利权)人(译)	心脏起搏器, INC.		
当前申请(专利权)人(译)	心脏起搏器, INC.		
[标]发明人	KANE MICHAEL J HAASL BENJAMIN J MAILE KEITH R		
发明人	KANE, MICHAEL J. HAASL, BENJAMIN J. MAILE, KEITH R.		
IPC分类号	A61N1/37 A61N1/375 A61B5/00		
CPC分类号	A61N1/3706 A61N1/37512 A61B5/0031 A61N1/36521 A61N1/3627 A61N1/36557 A61B5/0215 A61B5/0422 A61B5/0452 A61B5/686 A61B5/6869 A61B5/6882 A61B7/00 A61B7/04 A61N1/36564 A61N1/3756		
优先权	62/413766 2016-10-27 US		
外部链接	Espacenet USPTO		

摘要(译)

可植入医疗设备 (IMD) 配置有压力传感器。IMD包括壳体, 压力传感器和充满流体的腔体。壳体具有隔膜, 该隔膜暴露于壳体外部的环境。压力传感器具有压力传感器隔膜, 该压力传感器隔膜响应于施加到压力传感器隔膜的压力并提供压力传感器输出信号, 该信号表示施加到压力传感器隔膜的压力。流体填充腔与壳体的膜片和压力传感器的压力传感器膜片流体连通。流体填充腔被配置为将与环境施加的压力相关的措施传递到壳体的隔膜到压力传感器的压力传感器隔膜。

