



US 20170172550A1

(19) **United States**

(12) **Patent Application Publication**
Mukherjee et al.

(10) **Pub. No.: US 2017/0172550 A1**
(43) **Pub. Date: Jun. 22, 2017**

(54) **SURGICAL INSTRUMENTS INCLUDING SENSORS**

A61B 17/068 (2006.01)
A61B 17/29 (2006.01)
A61B 5/022 (2006.01)
A61B 5/107 (2006.01)

(71) Applicant: **Covidien LP**, Mansfield, MA (US)

(72) Inventors: **Nilay Mukherjee**, Acton, MA (US);
Andrew Miesse, Durham, CT (US);
David C. Racenet, Killingworth, CT (US)

(52) **U.S. Cl.**
CPC *A61B 17/00* (2013.01); *A61B 5/022* (2013.01); *A61B 5/0261* (2013.01); *A61B 5/1072* (2013.01); *A61B 17/068* (2013.01); *A61B 17/29* (2013.01); *A61B 5/4836* (2013.01); *A61B 2017/00026* (2013.01); *A61B 2017/00057* (2013.01); *A61B 2017/00115* (2013.01); *A61B 2017/00199* (2013.01); *A61B 2090/065* (2016.02)

(21) Appl. No.: **15/370,145**

(22) Filed: **Dec. 6, 2016**

Related U.S. Application Data

(60) Provisional application No. 62/269,223, filed on Dec. 18, 2015.

Publication Classification

(51) **Int. Cl.**
A61B 17/00 (2006.01)
A61B 5/026 (2006.01)
A61B 5/00 (2006.01)

(57) **ABSTRACT**

A surgical instrument includes a handle portion, first and second jaw members operably coupled to the handle portion, and first and second sensors associated with the first or second jaw members. The first sensor is configured to measure local perfusion in tissue grasped between the first and second jaw members, and the second sensor is configured to measure a pressure applied to the tissue by the first and second jaw members.

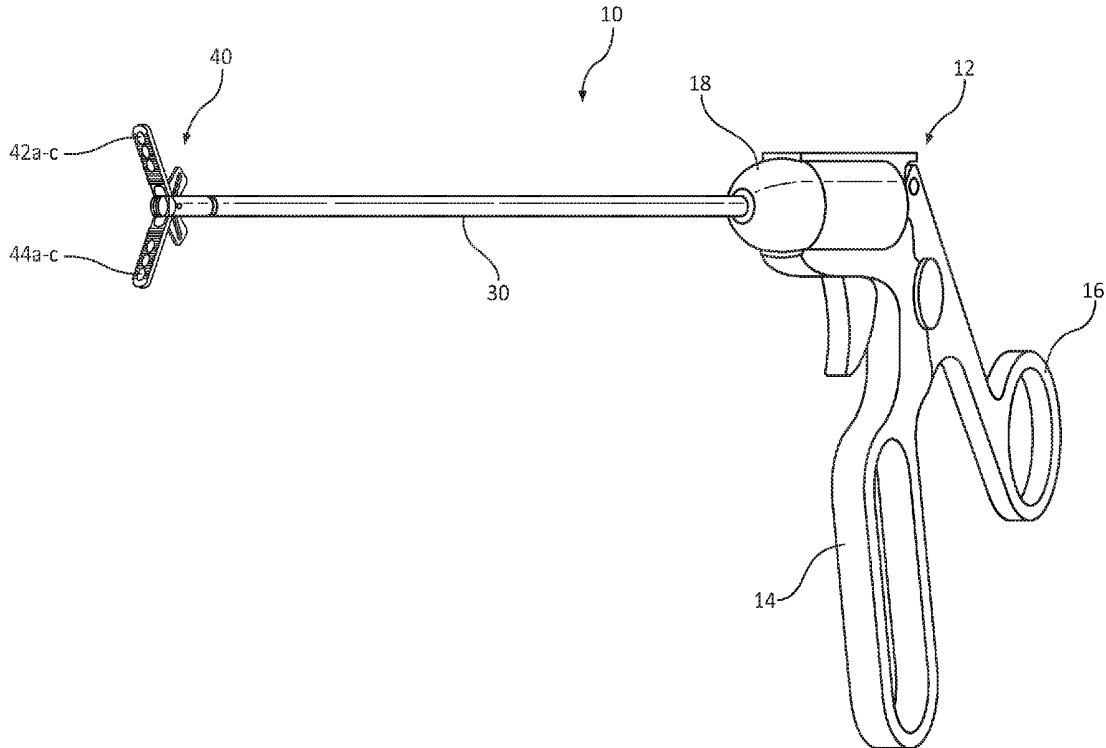

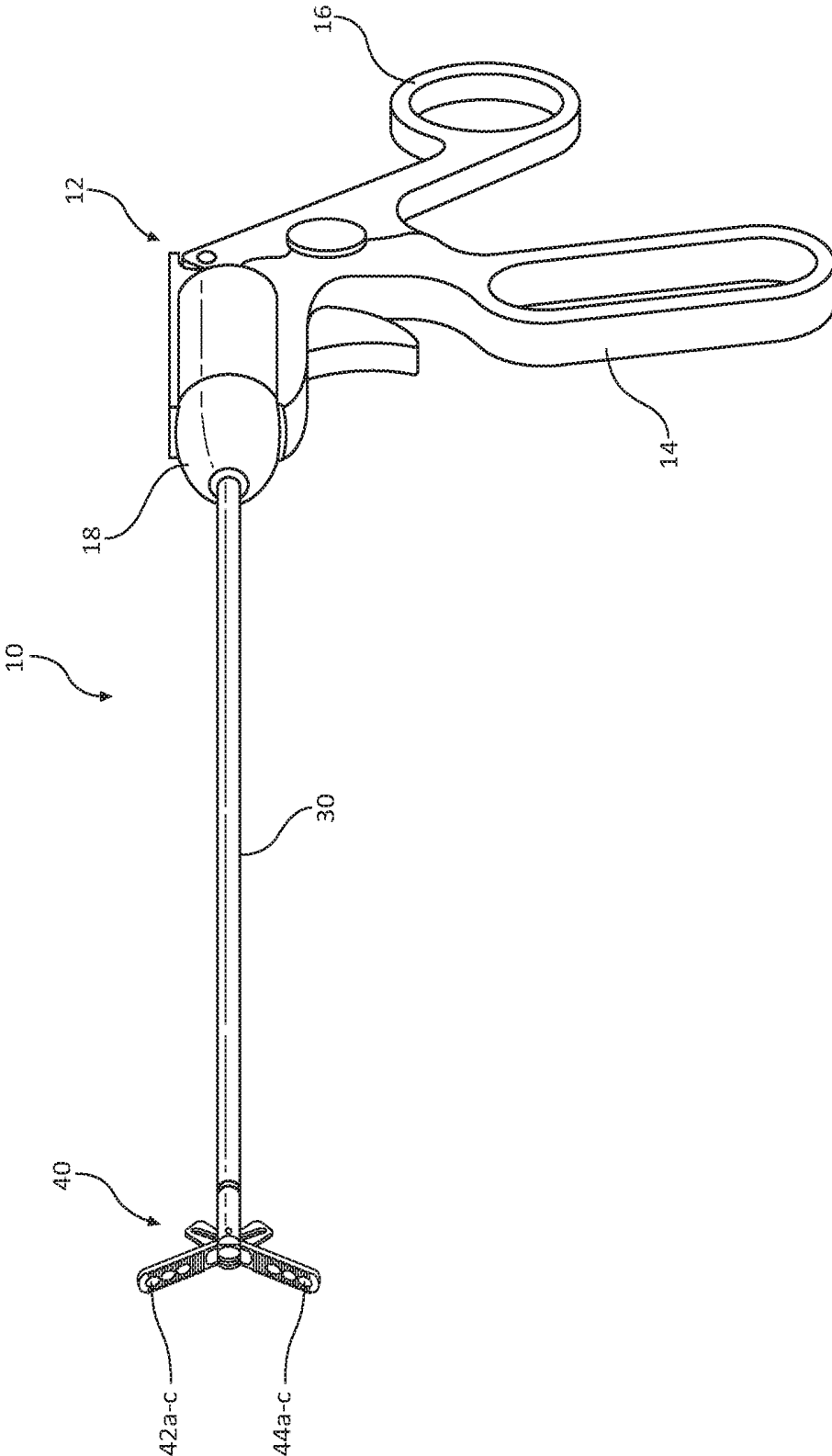

FIG. 1A

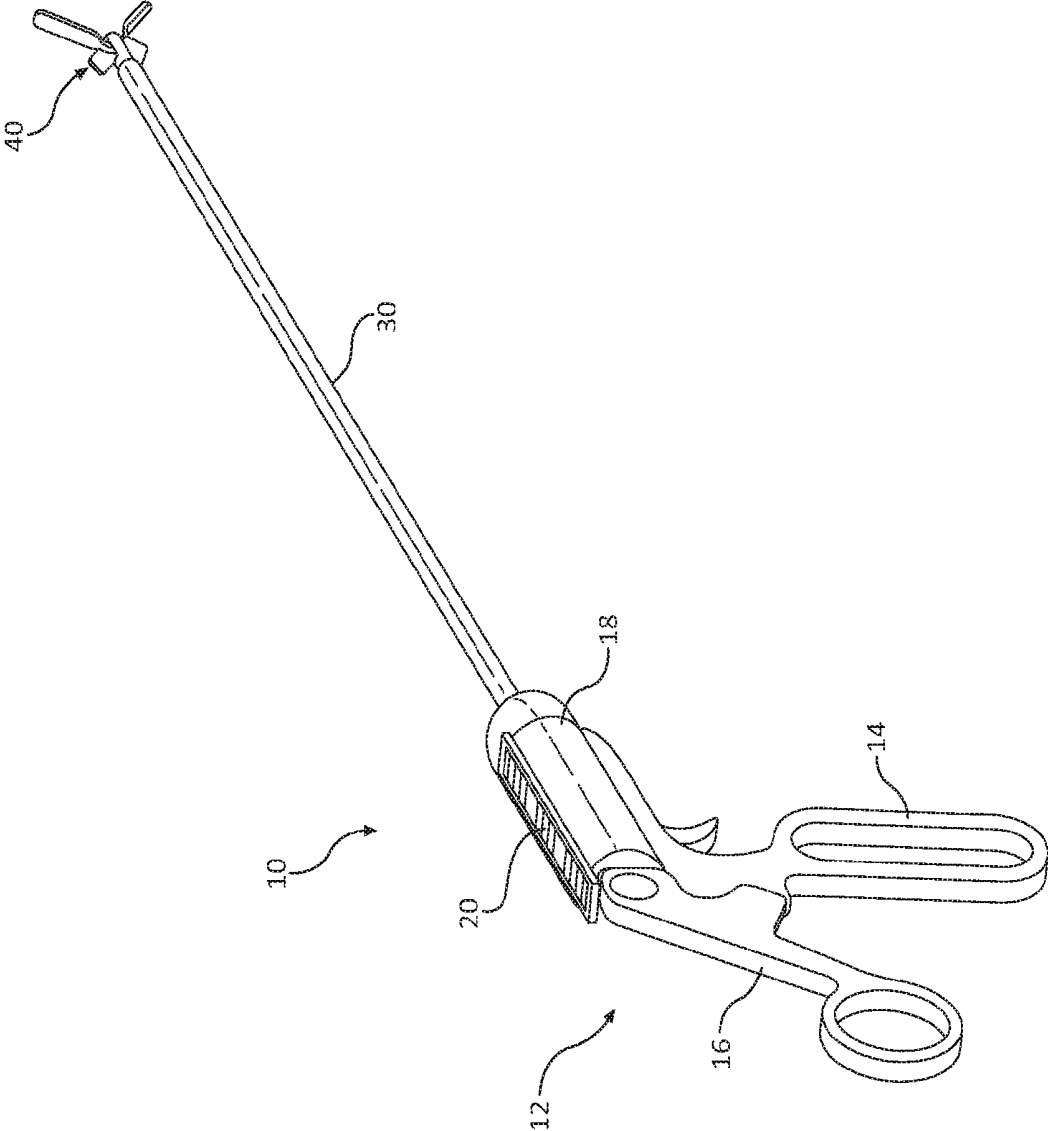

FIG. 1B

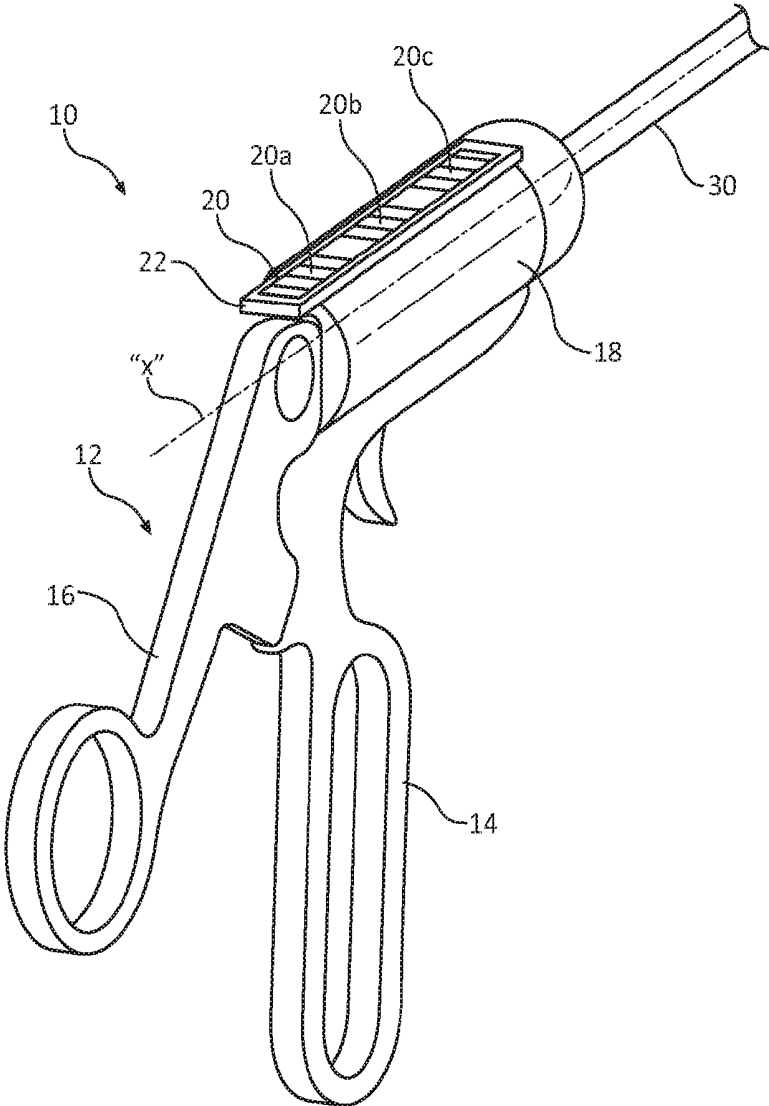

FIG. 2

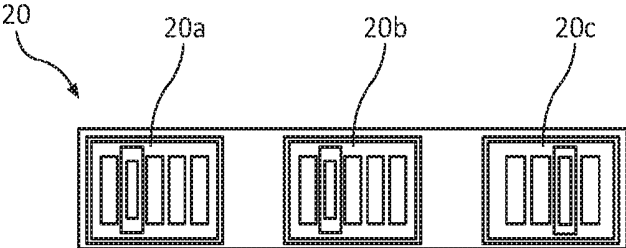

FIG. 3

SURGICAL INSTRUMENTS INCLUDING SENSORS

CROSS-REFERENCE TO RELATED APPLICATIONS

[0001] The present application claims priority to, and the benefit of, U.S. Provisional Patent Application Ser. No. 62/269,223, filed on Dec. 18, 2015, the entire contents of which are hereby incorporated by reference.

BACKGROUND

[0002] 1. Technical Field

[0003] The present disclosure relates to surgical instruments and, more particularly, to surgical graspers for grasping tissue and for determining characteristics of the grasped tissue in preparation for performing various surgical procedures.

[0004] 2. Background of Related Art

[0005] Colorectal surgery sometimes requires anastomosis, which involves resecting a piece of diseased bowel tissue and creating a new connection between presumably two healthy bowel segments. Typically, before performing the anastomosis, the amount of tissue to be resected is estimated using visual indicia of the bowel. The goal is to preserve as much healthy tissue as possible while at the same time removing all of the diseased tissue.

[0006] A risk involved in performing an anastomotic procedure is anastomotic leaks, which can be a serious complication that can result in an acute life-threatening condition. The anastomotic leaks are typically caused by a failure to resect all of the diseased tissue. Current methods used in estimating the amount of tissue to be resected during an anastomotic procedure are sometimes inadequate in preventing all anastomotic leaks.

[0007] Accordingly, a need exists for surgical instruments that can sense, either sequentially or simultaneously, a multitude of parameters and factors of the bowel tissue to aid a surgeon in performing a more successful anastomotic surgical procedure.

SUMMARY

[0008] In one aspect of the present disclosure, a surgical instrument is provided and includes a handle portion, first and second jaw members, and first and second sensors. The jaw members are operably coupled to the handle portion and movable relative to one another in response to an actuation of the handle portion. The first sensor is associated with the first or second jaw member and is configured to measure local perfusion in tissue grasped between the first and second jaw members. The second sensor is associated with the first or second jaw member and configured to measure a pressure applied to the tissue by the first and second jaw members.

[0009] In some embodiments, each of the first and second jaw members may include a tissue contacting surface. The first and second sensors may be disposed on the tissue contacting surface of the first or second jaw member.

[0010] In some embodiments, the surgical instrument may include third and fourth sensors. The third sensor may be configured to measure the local perfusion in the tissue grasped between the first and second jaw members, and the fourth sensor may be configured to measure the pressure applied to the tissue by the first and second jaw members.

The first and second sensors may be disposed on the tissue contacting surface of the first jaw member, and the third and fourth sensors may be disposed on the tissue contacting surface of the second jaw member.

[0011] In some embodiments, the first and third sensors may overlap with one another and the second and fourth sensors may overlap with one another when the first and second jaw members are in an approximated position.

[0012] In some embodiments, the tissue contacting surface of the first and/or second jaw member may define a plurality of teeth configured for atraumatically grasping tissue.

[0013] In some embodiments, the first and second sensors may be arranged in a linear array along a longitudinal axis defined by the first jaw member.

[0014] In some embodiments, the surgical instrument may further include a display disposed on the handle portion and in communication with the first and second sensors. The display may be configured to display the measured local perfusion and the measured pressure applied to the tissue by the first and second jaw members. The display may include three discreet display sections disposed in a linear array along a longitudinal axis defined by the handle portion. The display may have an elongated configuration and extend along a longitudinal axis defined by the handle portion. The display may be configured to display an index representative of the ratio of a surface perfusion pressure measured using the first and second sensors and a systemic blood pressure.

[0015] In some embodiments, the first sensor may be a Doppler flow sensor configured to measure the local perfusion in the tissue using Laser-Doppler flowmetry, light scattering, and/or light absorption.

[0016] In some embodiments, the surgical instrument may further include a third sensor associated with the first or second jaw member. The third sensor is configured to measure a thickness of the tissue grasped between the first and second jaw members. The first jaw member may include a tissue contacting surface having each of the first, second, and third sensors disposed thereon. The third sensor may be a slide potentiometer, a rotational potentiometer, or a linear variable differential transformer.

[0017] In some embodiments, the surgical instrument may be pre-programmed to clamp tissue at a predetermined clamping pressure known to cease perfusion through the tissue.

[0018] In another aspect of the present disclosure, a method of performing a surgical procedure is provided. The method includes positioning tissue between first and second jaw members of a surgical instrument, determining local perfusion of the tissue using a first sensor associated with the first or second jaw member, determining a pressure applied to the tissue by the first and second jaw members using a second sensor associated with the first or second jaw member, determining a surface perfusion pressure of the tissue using the determined local perfusion and the determined pressure applied to the tissue, and determining, using the measured surface perfusion pressure of the tissue, whether the tissue is viable.

[0019] Some methods may further include displaying the determined local perfusion and the determined pressure applied to the tissue on a display of the surgical instrument.

[0020] Some methods may further include displaying on the display an index representative of the ratio of the surface perfusion pressure and a systemic blood pressure.

[0021] Some methods may further include clamping the tissue between the first and second jaw members at a predetermined clamping pressure known to cease perfusion through the tissue, reducing the clamping pressure at a predetermined rate, and sending the determined pressure to the display at the moment when perfusion through the tissue restarts.

[0022] Some methods may further include determining a thickness of the tissue using a third sensor associated with one of the first or second jaw members, and determining, using the measured thickness of the tissue, a size of staples to be used in stapling the tissue.

[0023] These and other objects will be more clearly illustrated below by the description of the drawings and the detailed description of the preferred embodiments.

BRIEF DESCRIPTION OF THE DRAWINGS

[0024] The accompanying drawings, which are incorporated in and constitute a part of this specification, illustrate embodiments of the present disclosure and, together with the detailed description of the embodiments given below, serve to explain the principles of the disclosure.

[0025] FIG. 1A is a front, perspective view of a surgical instrument including sensors and a display, in accordance with the present disclosure;

[0026] FIG. 1B is a rear, perspective view of the surgical instrument of FIG. 1A;

[0027] FIG. 2 is an enlarged view of a handle portion of the surgical instrument of FIG. 1A illustrating the display of the surgical instrument;

[0028] FIG. 3 is an enlarged view of the display of FIG. 2;

[0029] FIG. 4 is an enlarged view of a jaw assembly of the surgical instrument of FIG. 1A illustrating sensors incorporated therein; and

[0030] FIG. 5 is a top view of the surgical instrument of FIG. 1A illustrating the jaw assembly grasping tissue.

DETAILED DESCRIPTION

[0031] Embodiments of the presently disclosed surgical instruments and systems will now be described in detail with reference to the drawing figures wherein like reference numerals identify similar or identical elements. As used herein and as is traditional, the term “distal” will refer to that portion which is further from the user while the term “proximal” will refer to that portion which is closer to the user.

[0032] With reference to FIGS. 1A and 1B, a surgical instrument, such as, for example, a tissue grasper 10 is provided. The tissue grasper 10 is configured to grasp tissue and sense a multiplicity of biological parameters of the grasped tissue to assist a surgeon in performing a surgical procedure, for example, an anastomotic surgical procedure, as will be described in detail herein. The tissue grasper 10 generally includes a handle portion 12, an elongated shaft 30, and a jaw assembly 40.

[0033] The handle portion 12 of the tissue grasper 10 includes a stationary handle 14 and a pivoting or movable handle 16 pivotably coupled to the stationary handle 14. Manipulation of the pivoting handle 16 relative to the stationary handle 14 effects a closing of the jaw assembly 40 to grasp tissue. The handle portion 12 of the tissue grasper 10 includes a longitudinal body portion 18 formed with the stationary handle 14. The body portion 18 has a display 20,

for example, an LED display or liquid-crystal display (“LCD”) for displaying various tissue parameters measured by various sensors 42a-c, 44a-c of the tissue grasper 10.

[0034] With reference to FIGS. 2 and 3, the body portion 18 of the handle portion 12 defines a longitudinal axis “X” that is coaxial with a longitudinal axis defined by the elongated shaft 30. The body portion 18 has a planar upper surface 22 on which the display 20 is situated. It is contemplated that the display 20 may be disposed at any suitable location of the body portion 18 or on any other component of the tissue grasper 10.

[0035] The display 20 may have multiple display sections, for example, three display sections 20a, 20b, 20c, arranged in a linear array along the longitudinal axis “X.” It is contemplated that the display 20 may include more or less than three discrete display sections. A first display section 20a of the display 20 is configured to display a visual indication of a measured tissue perfusion of tissue grasped by the tissue grasper 10. A second display section 20b of the display 20 is configured to display a visual indication of a measured amount of pressure being applied to tissue grasped by the tissue grasper 10. A third display section 20c of the display 20 is configured to display a measured thickness of the tissue grasped by the tissue grasper 10.

[0036] The visual indication displayed by each of the display sections 20a, 20b, 20c includes a range of colors increasing in brightness from a proximal portion to a distal portion thereof. For example, when viewing each of the first and second display sections 20a, 20b in a proximal to distal direction, the first and second display sections 20a, 20b may each be green, yellow, orange, and then red, with each color portion gradually blending into the adjacent color portion. Other colors and color arrangements for the first and second display sections 20a, 20b are contemplated. The tissue grasper 10 may be configured such that when the green of the first display section 20a is lit, this may indicate a relatively high tissue perfusion being measured by the tissue grasper 10, whereas when the red of the first display section 20a is lit, this may indicate a relatively low tissue perfusion being measured by the tissue grasper 10. The information related to the tissue perfusion may be useful when making a determination on the viability of the tissue being grasped, as will be described in more detail below.

[0037] With reference to the second display section 20b of the display 20, when the green of the second display section 20b is lit, this may be indicative of a relatively low grasping or clamping pressure being applied to tissue by the tissue grasper 10, whereas when the red of the second display section 20b is lit, this may be indicative of a relatively high grasping or clamping pressure being applied to tissue by the tissue grasper 10. The clamping pressure measured by the tissue grasper 10 and displayed by the second display section 20b of the tissue grasper 10 is used in conjunction with the tissue perfusion displayed by the first display section 20a of the tissue grasper 10 to determine the perfusion pressure of the grasped tissue.

[0038] The perfusion pressure is measured by applying a sufficient amount of clamping pressure on the subject tissue until there is no perfusion (i.e., no blood flow) through the tissue, and then slowly reducing the clamping pressure until perfusion through the grasped tissue restarts. The pressure at which the perfusion restarts is the tissue perfusion pressure. For a detailed description of a method of measuring surface

perfusion pressure, reference may be made to U.S. Pat. No. 7,618,376, the entire contents of which are incorporated by reference herein.

[0039] The information related to the amount of pressure being applied to tissue by the tissue grasper **10** may also be useful in preventing over-compression of tissue to prevent damage to healthy tissue.

[0040] In viewing the third display section **20c** from a proximal to distal direction, the third display section **20c** may be grey, brown, violet, and black. In some embodiments, third display section **20c** may be grey, white, blue, purple, tan, green, and black. Other colors and color arrangements for the third display section **20c** are contemplated. When the grey (proximal portion) of the third display section **20c** is lit, this may be an indication that tissue grasped by the tissue grasper **10** has a relatively small thickness (i.e., the tissue is too thin to withstand being stapled), whereas when the black (distal portion) of the third display section **20c** is lit, this may be an indication that tissue grasped by the tissue grasper **10** has a relatively large thickness (i.e., the tissue is too thick to be stapled). The information related to tissue thickness may be useful for making a determination on the size of the staples to be used when performing a surgical anastomosis on the grasped tissue.

[0041] In some embodiments, instead of display **20** utilizing ranges of colors or brightness to illustrate the measured tissue parameters (e.g., tissue perfusion, tissue compression, and tissue thickness), the display **20** may display ranges of numbers or various numeral outputs. In particular, the first, second, and third display sections **20a**, **20b**, **20c** may display the number ranges 0 to 3, 0 to 5, 0 to 10, 0 to 100, or any other suitable range, to illustrate information about the tissue being grasped by the tissue grasper **10**. For example, when the first display section **20a** displays the number 0, this may be an indication that the grasped tissue has very little or no perfusion (i.e., no blood flow), whereas when the first display section **20a** displays the number 100, this may be an indication that the grasped tissue has a high perfusion (i.e., ideal blood flow).

[0042] In some embodiments, the display **20** may illustrate information about grasped tissue utilizing any suitable indicia, for example, words such as poor, satisfactory, or good.

[0043] In some embodiments, tissue grasper **10** may not include display **20**, and instead, tissue grasper **10** may be configured to be connected to or be in communication with another type of display, for example, a tablet, a cell phone, a computer monitor, a laptop, or any suitable display device. Tissue grasper **10** may be connected to any of the aforementioned display devices via USB wires, Wi-Fi, or the like.

[0044] With reference to FIGS. 1A, 1B, and 4, the elongated shaft **30** of tissue grasper **10** extends distally from the handle portion **12** and houses an actuation rod (not explicitly shown). The elongated shaft **30** may be rotatable with respect to the handle portion **12** to rotate the jaw assembly **40** about the longitudinal axis "X." The elongated shaft **30** has two prongs **32**, **34** formed at its distal end **30b**. A pivot pin **36** extends transversely through the prongs **32**, **34** and the jaw assembly **40** to provide a point about which the jaw members **42**, **44** of the jaw assembly **40** pivot. The actuation rod has a proximal end (not shown) operably coupled to the movable trigger **16** (FIGS. 1A, 1B), and a distal end (not shown) extending between the prongs **32**, **34** and which is operably coupled to the jaw assembly **40**.

[0045] With reference to FIGS. 4 and 5, the jaw assembly **40** includes first and second juxtaposed jaw members **42**, **44**, respectively, which are simultaneously movable between a substantially approximated position, in which the jaw members **42**, **44** are in relatively close relation to one another, and a spaced position, in which the jaw members **42**, **44** are separated at least a sufficient distance to receive tissue therebetween, for example, tissue "T." The jaw assembly **40** includes a first proximal portion or a first flange **46** extending proximally from the first jaw member **42**, and a second proximal portion or a second flange **48** extending proximally from the second jaw member **44**. The flanges **46**, **48** each include an elongated angled cam slot **50**, **52** defined there-through configured to engage the distal end of the actuation rod (not explicitly shown) that drives the opening and closing of the jaw members **42**, **44** as the actuation rod moves through the cam slots **50**, **52**. As such, manipulation of the pivoting handle **16** (FIGS. 1A, 1B) relative to the stationary handle **14** actuates the actuation rod to effect an opening or a closing of the jaw assembly **40** about tissue "T."

[0046] With continued reference to FIGS. 4 and 5, the jaw members **42**, **44** each have a tissue contacting surface **54**, **56** such that when the jaw assembly **40** is in the closed configuration, tissue "T" is grasped between the tissue contacting surfaces **54**, **56**. The jaw members **42**, **44** each have a first sensor **42a**, **44a**, a second sensor **42b**, **44b**, and a third sensor **42c**, **44c**, disposed on respective tissue contacting surfaces **54**, **56**. The sensors **42a-c**, **44a-c** are arranged on respective tissue contacting surfaces **54**, **56** in a linear array along a longitudinal axis defined by respective jaw members **42**, **44**. In some embodiments, the sensors **42a-c**, **44a-c** may be arranged on respective tissue contacting surfaces **54**, **56** in any suitable manner.

[0047] The first sensors **42a**, **44a** of the jaw assembly **40** are perfusion sensors, for example, Doppler flow sensors, configured to measure local perfusion (i.e., blood flow) through tissue grasped between the jaw members **42**, **44**. The first sensors **42a**, **44a** may measure perfusion of the grasped tissue on the basis of known techniques, such as Laser-Doppler Flowetry ("LDF"), measuring light scattering, and/or measuring absorption of light from one or more LED's or other light sources. For a detailed description of LDF technology, reference may be made to U.S. Pat. Nos. 4,109,647 and 4,862,894, the entire contents of each of which are incorporated by reference herein.

[0048] In some embodiments, only one of the tissue contacting surfaces **54**, **56** of the jaw assembly **40** has a perfusion sensor. The first sensors **42a**, **44a** are in communication, via lead wires or wireless connection, with the first display section **20a** of the display **20** such that upon the first sensors **42a**, **44a** measuring the perfusion in grasped tissue, the first sensors **42a**, **44a** transmit the measurement data to the first display section **20a**, which displays the measurement in any of the manners described above with reference to FIGS. 2 and 3 (e.g., a range of colors, brightness levels, numbers, words.)

[0049] In some embodiments, the first sensors **42a**, **44a** may also be in communication, via lead wires or wireless connection, with a computing device or processor (not shown) such as a laser Doppler monitor, which processes the information collected by the first sensors **42a**, **44a** to calculate the tissue perfusion. The computing device may also be in communication, via lead wires or wireless connection, with the first display section **20a** to send the processed

information related to the tissue perfusion to the first display section 20a so that the first display section 20a can display the tissue perfusion in any of the manners described above with reference to FIGS. 2 and 3 (e.g., colors, brightness levels, numbers, words.)

[0050] With continued reference to FIGS. 4 and 5, the second sensors 42b, 44b of the jaw assembly 40 are pressure sensors or pressure measuring devices, for example, MEMS devices. For a detailed description of various MEMS devices, reference may be made to U.S. Pat. No. 8,808,311, the entire contents of which are incorporated by reference herein. The second sensors 42b, 44b are configured to measure the amount of pressure applied by the tissue grasper 10 to the grasped tissue (i.e., the clamping pressure). In some embodiments, only one of the tissue contacting surfaces 54, 56 has a pressure sensor. The second sensors 42b, 44b are in electrical communication, via lead wires of wireless connection, with the second display section 20b of the display 20 such that upon the second sensors 42b, 44b measuring the clamping pressure applied to the grasped tissue, the second sensors 42b, 44b transmit the measurement data to the second display section 20b, which displays the measurement in any of the manners described above with reference to FIGS. 2 and 3 (e.g., colors, brightness levels, numbers, words.) Additionally or alternately, the second sensors 42b, 44b may send the measured clamping pressure to the computing device for processing, which then sends the information to the display 20.

[0051] The third sensors 42c, 44c of the jaw assembly 40 are gap determination elements, for example, slide potentiometers, rotational potentiometers, devices used to measure impedance between the contacting surfaces 54, 56, or Linear Variable Differential Transformers (“LVDT”), configured to measure the thickness of the grasped tissue by measuring the gap distance between the jaw members 42, 44. For a detailed description of various sensors capable of measuring tissue thickness, reference may be made to U.S. Pat. No. 8,002,795, the entire contents of which are incorporated by reference herein. In some embodiments, only one of the tissue contacting surfaces 54, 56 has a gap determination element. The third sensors 42c, 44c are in electrical communication, via wire leads or wireless connection, with the third display section 20c of the display 20 such that upon the third sensors 42c, 44c measuring the tissue thickness of the grasped tissue, the third sensors 42c, 44c transmit the measurement data to the third display section 20c, which displays the measurement in any of the manners described above with reference to FIGS. 2 and 3 (e.g., colors, brightness levels, numbers, words.) Additionally or alternately, the third sensors 42c, 44c may be in communication, via lead wires or wireless connection, to the computing device, which receives the tissue thickness measurements from the third sensors 42c, 44c, and processes the measurement data and then sends the information to the display 20.

[0052] In some embodiments, the display 20 may include a fourth display section (not shown) configured to display an index representative of the ratio of the surface perfusion pressure measured by first sensors 42a, 44a and second sensors 42b, 44b of the tissue grasper 10, and a systemic blood pressure measured by a blood pressure cuff (not shown), as will be described in detail below.

[0053] In operation, the tissue grasper 10 may be used prior to, during, or after a surgical procedure, for example, an anastomotic surgical procedure, to gather various data

about the subject tissue. In an anastomotic surgical procedure, unhealthy or diseased bowel tissue is resected and the ends of the remaining healthy segments of bowel are stapled together to recreate a continuous bowel. Prior to stapling the ends of the separate bowel segments to one another, the viability of the ends of the separate bowel segments should be assessed in order to predict the likelihood of post-surgery anastomotic leaks or other adverse outcomes. To aid in making this viability assessment, a surgeon may make use of the tissue grasper 10 of the present disclosure.

[0054] In use of the tissue grasper 10, each of the two ends of the presumably healthy bowel segments are grasped, either separately or together, between the tissue contacting surfaces 54, 56 of the jaw assembly 40. While monitoring the perfusion reading (i.e., blood flow) displayed on the first display section 20a of the tissue grasper 10, the pivoting handle 16 is manipulated to gradually increase the clamping pressure until the perfusion reading indicates that no blood flow or virtually no blood flow is moving through the grasped tissue. While continuously monitoring both the first and second display sections 20a, 20b, the movable handle 16 of the tissue grasper 10 is manipulated to gradually reduce the amount of clamping pressure being applied to the tissue. The clamping pressure is reduced until first display section 20a displays a perfusion reading indicating that blood flow has returned to the grasped tissue. At the moment that the perfusion reading indicates that the blood flow is returned, the clamping pressure reading displayed by the second display section 20b is noted, which is the local perfusion pressure of the grasped tissue. The measured local perfusion pressure may be used to assess the viability of the grasped tissue. Additionally or alternately, the measured local perfusion pressure may be used in combination with other measurements, for example, a systemic blood pressure reading, to aid in making the determination of the viability of the tissue.

[0055] The systemic blood pressure may be taken using any suitable device, for example, a blood pressure cuff, applied to any suitable body portion of the patient, for example, the arm of the patient. An index may be calculated by taking a ratio of the local perfusion pressure measured by the tissue grasper 10 and the systemic blood pressure taken using the blood pressure cuff. The index may be calculated by the computing device and displayed as a number on the display 20 of the tissue grasper 10. The calculated index is predictive of whether an anastomotic leak may occur and/or the grade of an anastomotic leak. As such, a surgeon can use the index to make a determination on whether the two ends of the presumed healthy bowel segments are healthy enough to be stapled together and whether more tissue needs to be resected. For a detailed description of a method of calculating a perfusion index, reference may be made to U.S. Pat. No. 7,618,376, the entire contents of which were incorporated by reference above.

[0056] In some embodiments, the tissue grasper 10 may be pre-programmed to clamp tissue at a predetermined clamping pressure that is known to result in perfusion through the grasped tissue to stop. The tissue grasper 10 may also be pre-programmed to reduce the clamping pressure at a predetermined rate and automatically send the pressure reading to the computing device at the moment when perfusion through the grasped tissue restarts. The perfusion pressure reading may also be displayed on the display 20. This automated process eliminates human error in operating the

tissue grasper **10** by controlling the amount of clamping pressure being applied to the tissue instead of the surgeon.

[0057] The tissue grasper **10** may also be used to determine the size of the staples to be used in stapling the bowel segments together. The staple size may be determined by viewing the third display section **20c** of the tissue grasper **10**, which indicates the thickness of the grasped tissue. The leg height of the staples selected for the stapling procedure will correspond to the thickness of the tissue. It is contemplated that the tissue thickness measured by the third sensors **42c**, **44c** may be sent to the computing device, which has stored therein a look-up table that contains a staple size corresponding to each tissue thickness measurement.

[0058] In addition to the tissue grasper **10** being used to ensure that the tissue is in condition for stapling or acceptable for stapling, the tissue grasper **10** may also be used as a check after the staples have been fired to ensure that the tissue is healthy (e.g., has good blood flow, is healing properly, etc).

[0059] The tissue grasper **10** may also be configured to be incorporated into a robotic surgical system (not shown). The robotic surgical system is powered locally or remotely, and has electronic control systems localized in a console or distributed within or throughout the robotic surgical system. The robotic surgical system permits a surgeon to remotely manipulate the tissue grasper to more precisely control the movement of the tissue grasper **10**. The tissue grasper **10** may be configured to send the measurements gathered by the sensors **42a-c**, **44a-c** to an interface of the robotic surgical system on which the measurements may be displayed for the surgeon to read.

[0060] Although the illustrative embodiments of the present disclosure have been described herein, it is understood that the disclosure is not limited to those precise embodiments, and that various other changes and modifications may be affected therein by one skilled in the art without departing from the scope or spirit of the disclosure. All such changes and modifications are intended to be included within the scope of the disclosure.

What is claimed is:

1. A surgical instrument, comprising:
 - a handle portion;
 - first and second jaw members operably coupled to the handle portion and movable relative to one another in response to an actuation of the handle portion;
 - a first sensor associated with one of the first or second jaw members and configured to measure local perfusion in tissue grasped between the first and second jaw members; and
 - a second sensor associated with one of the first or second jaw members and configured to measure a pressure applied to the tissue by the first and second jaw members.
2. The surgical instrument according to claim 1, wherein each of the first and second jaw members includes a tissue contacting surface, the first and second sensors being disposed on the tissue contacting surface of one of the first or second jaw members.
3. The surgical instrument according to claim 2, further comprising:
 - a third sensor configured to measure the local perfusion in the tissue grasped between the first and second jaw members; and

a fourth sensor configured to measure the pressure applied to the tissue by the first and second jaw members, wherein the first and second sensors are disposed on the tissue contacting surface of the first jaw member, and the third and fourth sensors are disposed on the tissue contacting surface of the second jaw member.

4. The surgical instrument according to claim 3, wherein the first and third sensors overlap with one another and the second and fourth sensors overlap with one another the first and second jaw members are in an approximated position.

5. The surgical instrument according to claim 2, wherein the tissue contacting surface of at least one of the first or second jaw members defines a plurality of teeth configured for atraumatically grasping tissue.

6. The surgical instrument according to claim 1, wherein the first and second sensors are arranged in a linear array along a longitudinal axis defined by the first jaw member.

7. The surgical instrument according to claim 1, further comprising a display disposed on the handle portion and in communication with the first and second sensors, wherein the display is configured to display the measured local perfusion and the measured pressure applied to the tissue by the first and second jaw members.

8. The surgical instrument according to claim 7, wherein the display includes three discreet display sections disposed in a linear array along a longitudinal axis defined by the handle portion.

9. The surgical instrument according to claim 7, wherein the display has an elongated configuration and extends along a longitudinal axis defined by the handle portion.

10. The surgical instrument according to claim 7, wherein the display is configured to display an index representative of the ratio of a surface perfusion pressure measured using the first and second sensors and a systemic blood pressure.

11. The surgical instrument according to claim 1, wherein the first sensor is a Doppler flow sensor configured to measure the local perfusion in the tissue using at least one of Laser-Doppler flowmetry, light scattering, or light absorption.

12. The surgical instrument according to claim 1, further comprising a third sensor associated with one of the first or second jaw members and configured to measure a thickness of the tissue grasped between the first and second jaw members.

13. The surgical instrument according to claim 12, wherein the first jaw member includes a tissue contacting surface, each of the first, second, and third sensors disposed on the tissue contacting surface.

14. The surgical instrument according to claim 12, wherein the third sensor is selected from the group consisting of a slide potentiometer, a rotational potentiometer, and a linear variable differential transformer.

15. The surgical instrument according to claim 1, wherein the surgical instrument is pre-programmed to clamp tissue at a predetermined clamping pressure known to cease perfusion through the tissue.

16. A method of performing a surgical procedure, comprising:

- positioning tissue between first and second jaw members of a surgical instrument, the first or second jaw members having a first sensor and a second sensor;
- determining local perfusion of the tissue using the first sensor;

determining a pressure applied to the tissue by the first and second jaw members using the second sensor;
determining a surface perfusion pressure of the tissue using the determined local perfusion and the determined pressure applied to the tissue; and
determining, using the measured surface perfusion pressure of the tissue, whether the tissue is viable.

17. The method according to claim 16, further comprising displaying the determined local perfusion and the determined pressure applied to the tissue on a display of the surgical instrument.

18. The method according to claim 17, further comprising displaying on the display an index representative of the ratio of the surface perfusion pressure and a systemic blood pressure.

19. The method according to claim 17, further comprising:

clamping the tissue between the first and second jaw members at a predetermined clamping pressure known to cease perfusion through the tissue;
reducing the clamping pressure at a predetermined rate;
and
sending the determined pressure to the display at the moment when perfusion through the tissue restarts.

20. The method according to claim 16, further comprising:

determining a thickness of the tissue using a third sensor associated with one of the first or second jaw members;
and
determining, using the measured thickness of the tissue, a size of staples to be used in stapling the tissue.

* * * * *

专利名称(译)	手术器械包括传感器		
公开(公告)号	US20170172550A1	公开(公告)日	2017-06-22
申请号	US15/370145	申请日	2016-12-06
[标]申请(专利权)人(译)	柯惠有限合伙公司		
申请(专利权)人(译)	COVIDIEN LP		
当前申请(专利权)人(译)	COVIDIEN LP		
[标]发明人	MUKHERJEE NILAY MIESSE ANDREW RACENET DAVID C		
发明人	MUKHERJEE, NILAY MIESSE, ANDREW RACENET, DAVID C.		
IPC分类号	A61B17/00 A61B5/026 A61B5/00 A61B17/068 A61B17/29 A61B5/022 A61B5/107		
CPC分类号	A61B17/00 A61B5/022 A61B5/0261 A61B5/1072 A61B17/068 A61B17/29 A61B2505/05 A61B2017/00026 A61B2017/00057 A61B2017/00115 A61B2017/00199 A61B2090/065 A61B5/4836 A61B17/282 A61B5/0084 A61B5/1076 A61B5/1459 A61B5/6843 A61B5/6847 A61B2017/00022 A61B2017/00106 A61B2017/2926 A61B2562/063 A01N1/0247		
优先权	62/269223 2015-12-18 US		
其他公开文献	US10624616		
外部链接	Espacenet USPTO		

摘要(译)

一种手术器械包括手柄部分，可操作地连接到手柄部分的第一和第二钳口构件，以及与第一或第二钳口构件相关联的第一和第二传感器。第一传感器配置成测量夹在第一和第二钳口构件之间的组织中的局部灌注，第二传感器配置成测量由第一和第二钳口构件施加到组织的压力。

