



US 20160331451A1

(19) **United States**

(12) **Patent Application Publication**
Nabutovsky et al.

(10) **Pub. No.: US 2016/0331451 A1**
(43) **Pub. Date: Nov. 17, 2016**

(54) **FEEDBACK SYSTEMS AND METHODS FOR RENAL DENERVATION UTILIZING BALLOON CATHETER**

Publication Classification

(71) Applicant: **St. Jude Medical, Cardiology Division, Inc.**, St. Paul, MN (US)
(72) Inventors: **Yelena Nabutovsky**, Sunnyvale, CA (US); **Edward Karst**, Los Angeles, CA (US); **Fujian Qu**, San Jose, CA (US)

(51) **Int. Cl.**
A61B 18/14 (2006.01)
A61B 5/0215 (2006.01)
A61B 5/00 (2006.01)
(52) **U.S. Cl.**
CPC *A61B 18/1492* (2013.01); *A61B 5/6853* (2013.01); *A61B 5/0215* (2013.01); *A61B 2018/00267* (2013.01)

(21) Appl. No.: **15/219,991**
(22) Filed: **Jul. 26, 2016**

(57) **ABSTRACT**

Related U.S. Application Data

(60) Continuation of application No. 15/063,600, filed on Mar. 8, 2016, now Pat. No. 9,427,283, which is a division of application No. 14/868,455, filed on Sep. 29, 2015, now Pat. No. 9,314,300, which is a division of application No. 13/836,193, filed on Mar. 15, 2013, now Pat. No. 9,179,973.

A renal denervation system includes an ablation catheter and an inflation balloon. The renal denervation catheter is insertable into a renal artery to perform a renal denervation procedure. The inflation balloon is inflatable within the renal artery, wherein one of a blood pressure condition in the renal artery resulting from operation of the inflation balloon and a performance characteristic of the inflation balloon indicates efficacy of the renal denervation procedure.

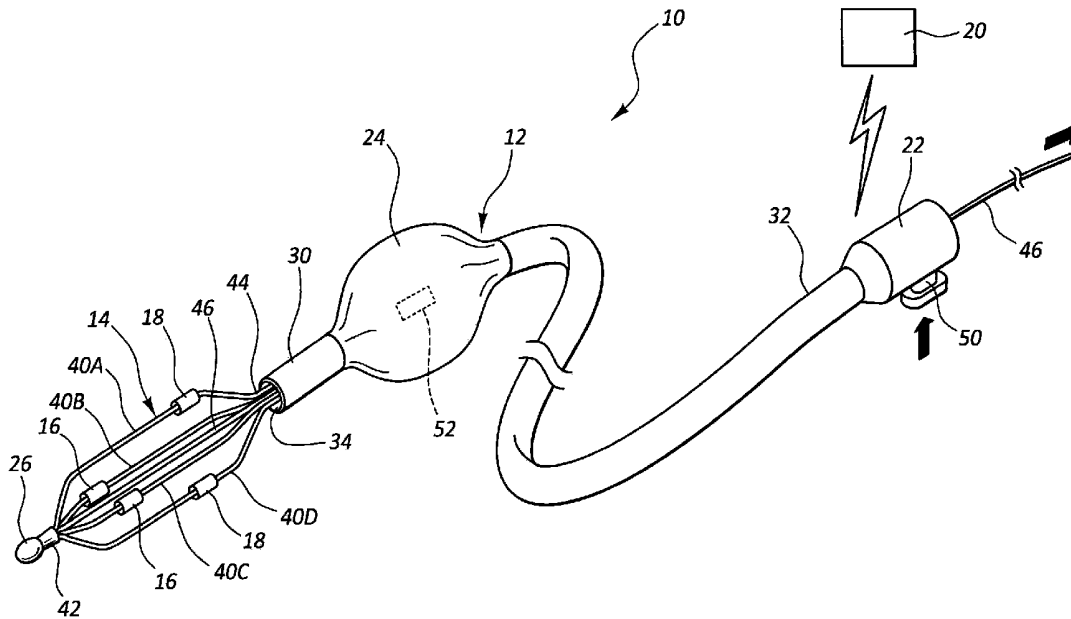

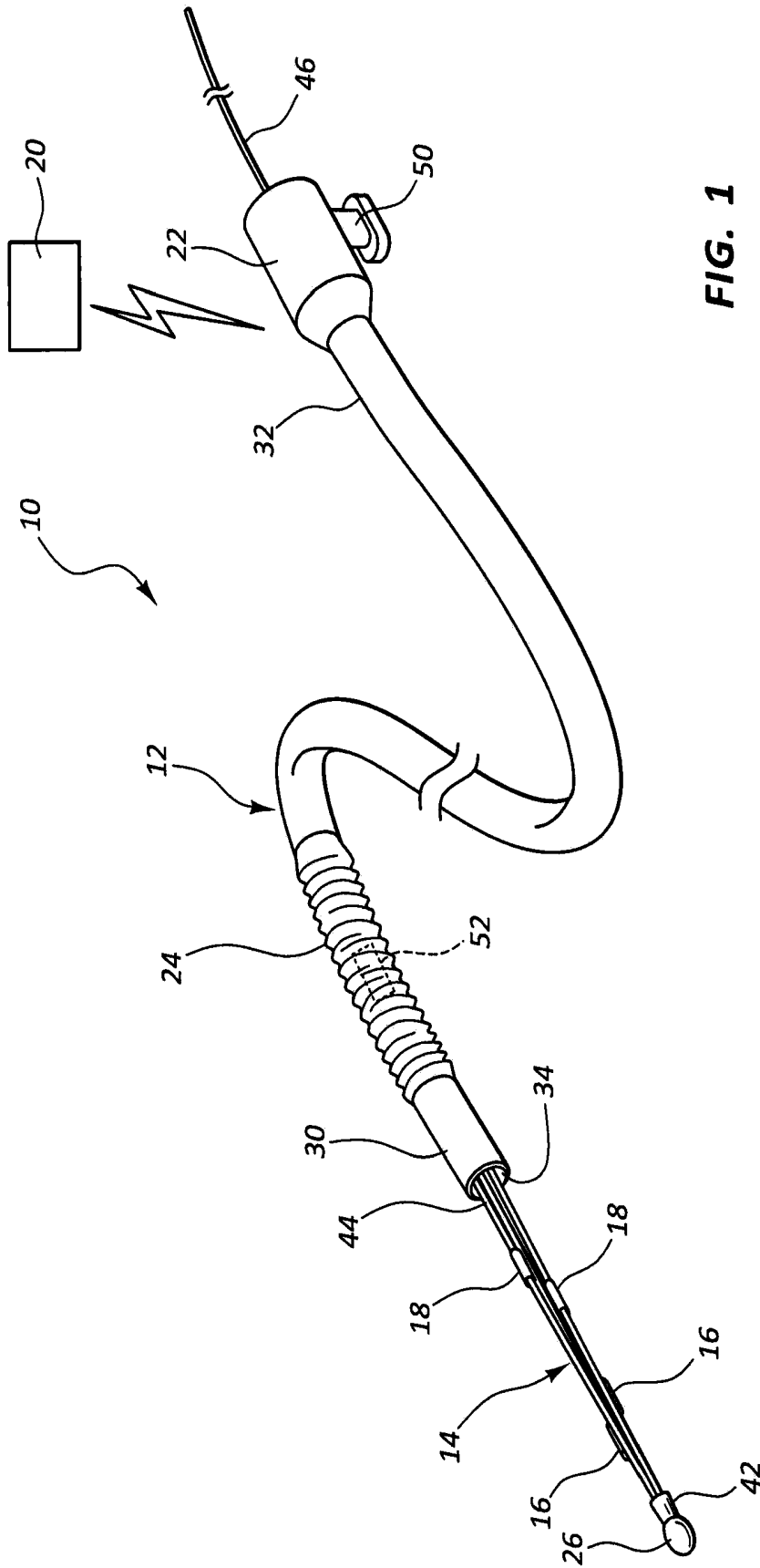

FIG. 1

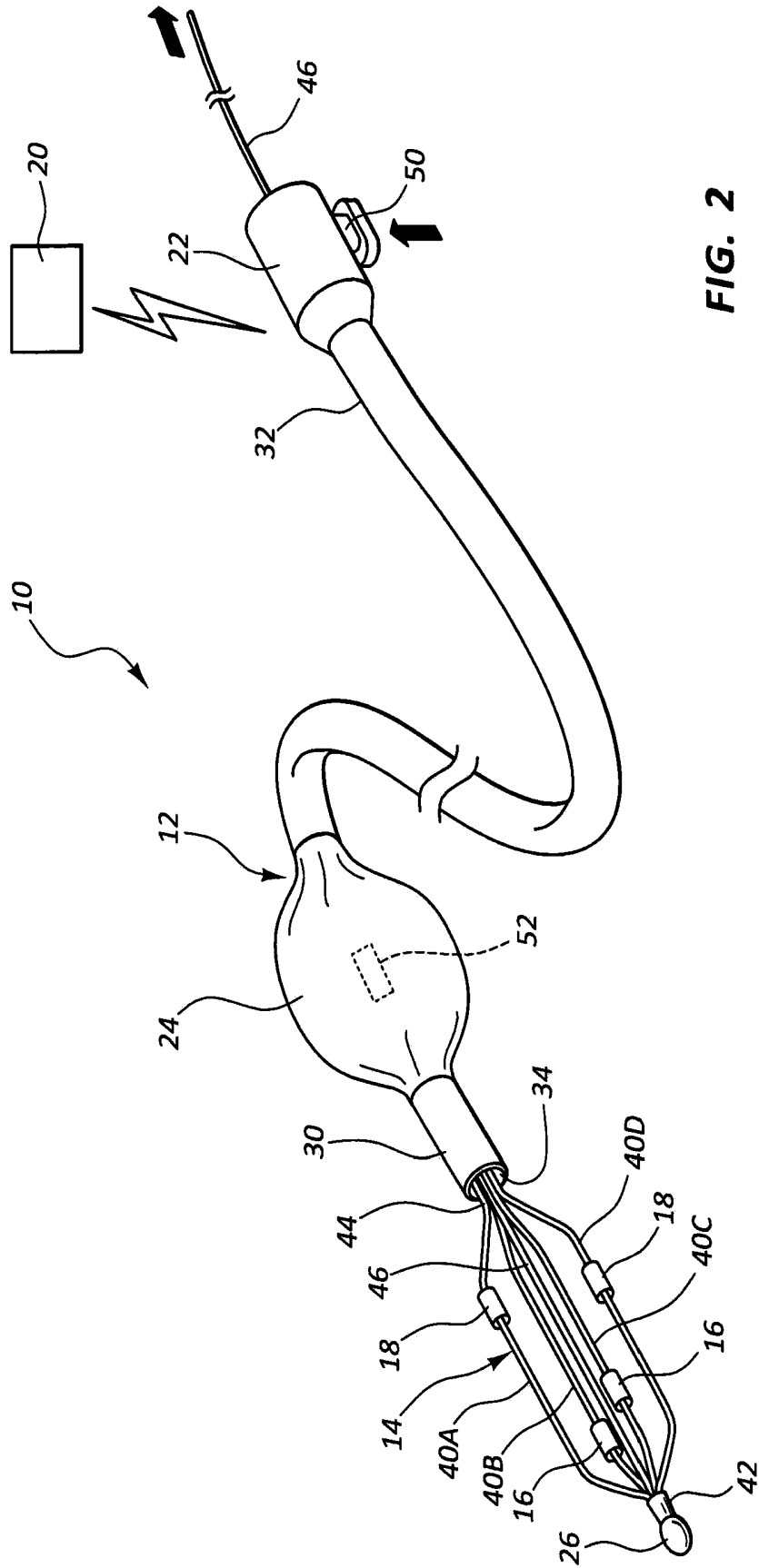

FIG. 2

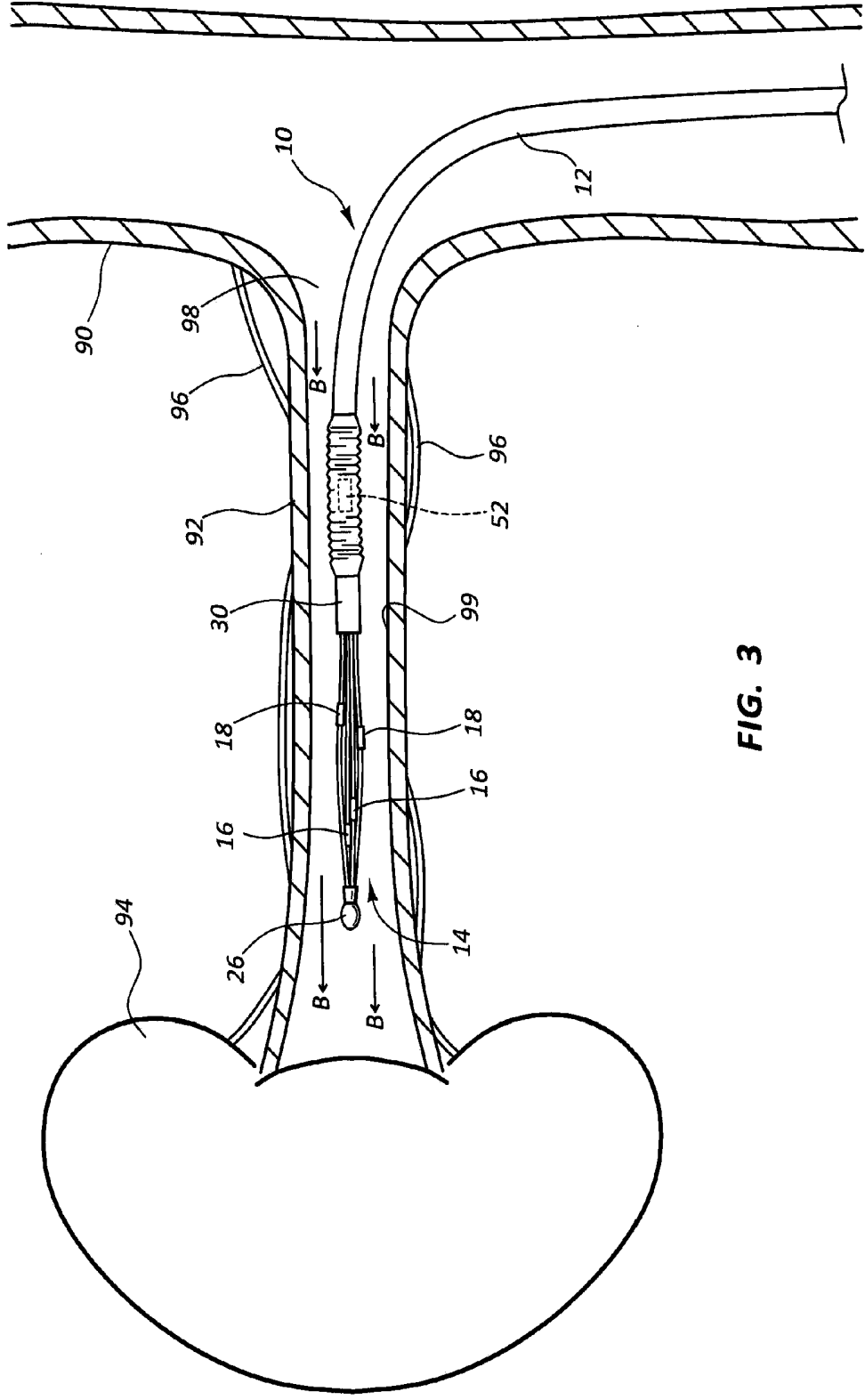

FIG. 3

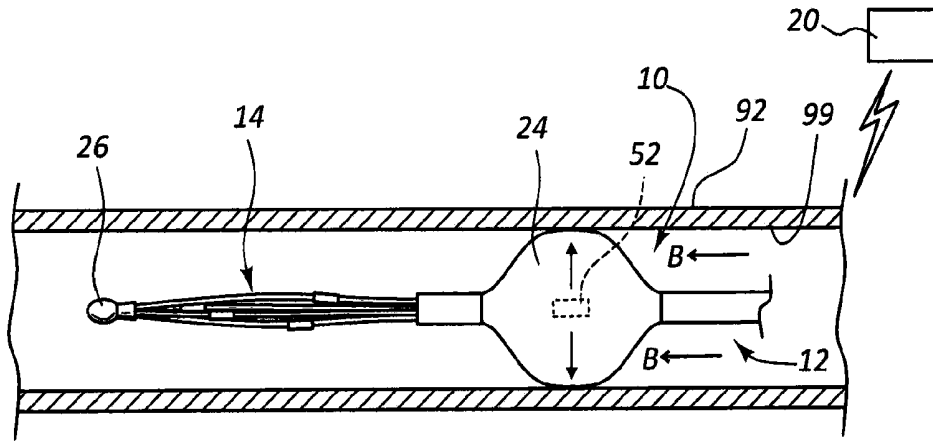

FIG. 4

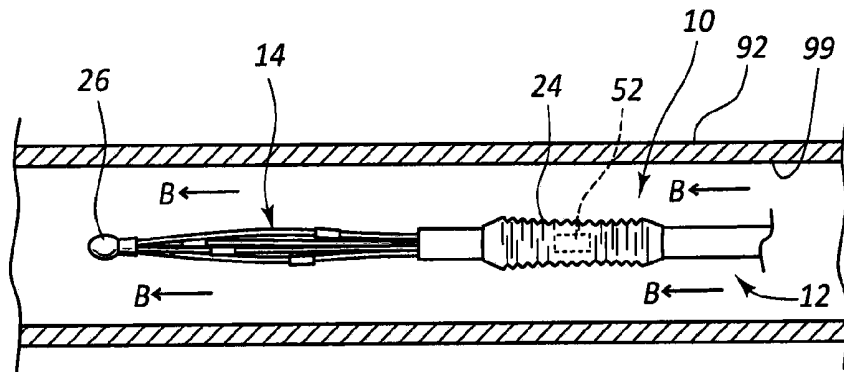

FIG. 5

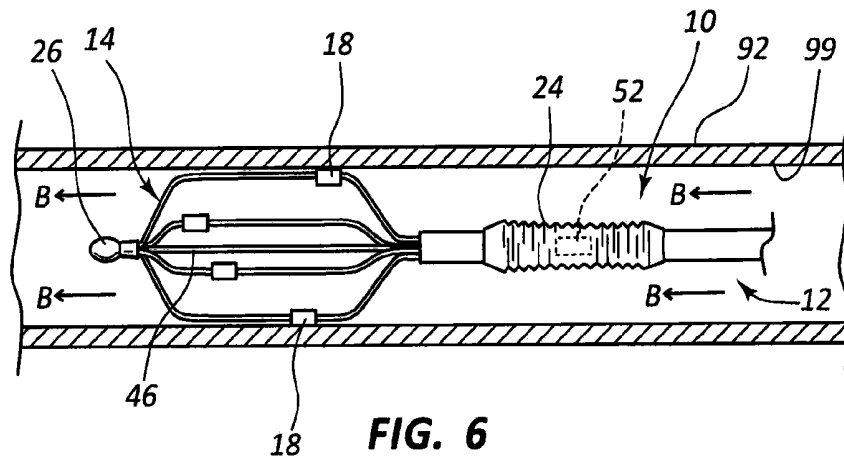

FIG. 6

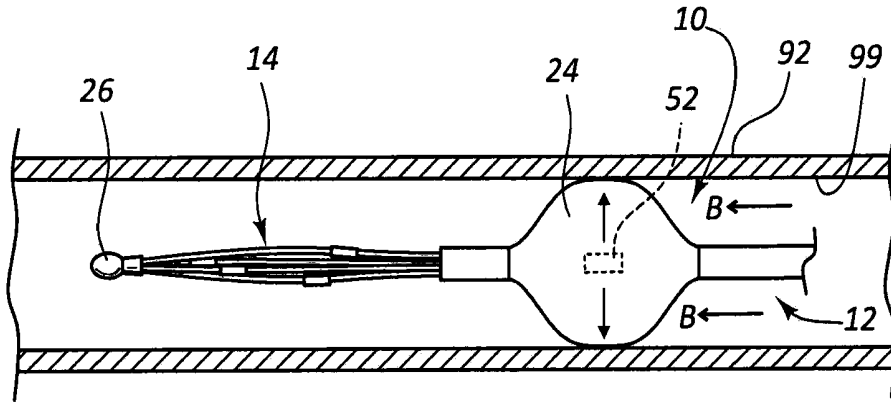

FIG. 7

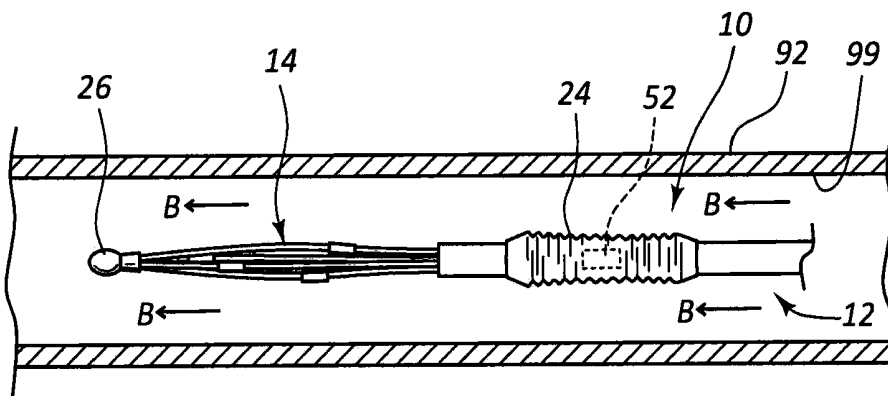

FIG. 8

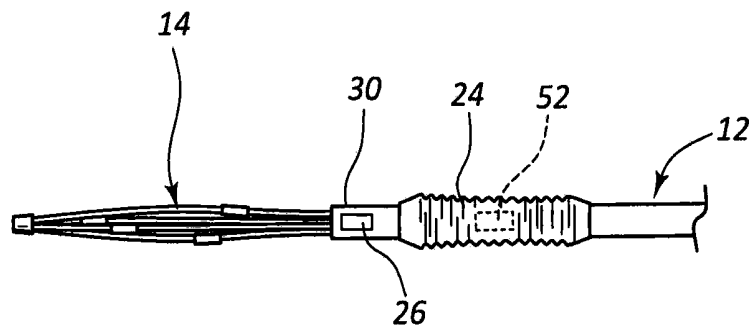

FIG. 9

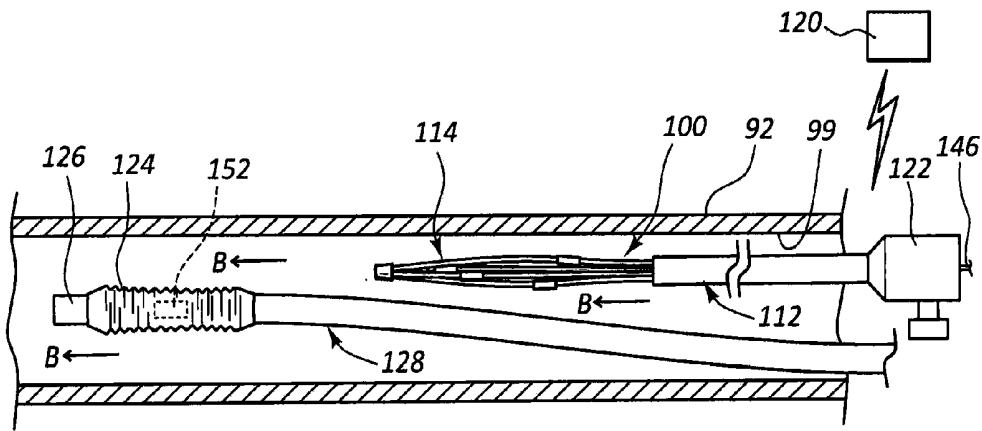

FIG. 10

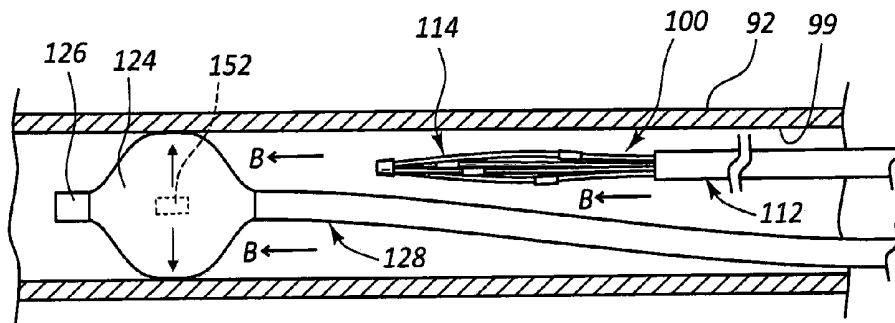

FIG. 11

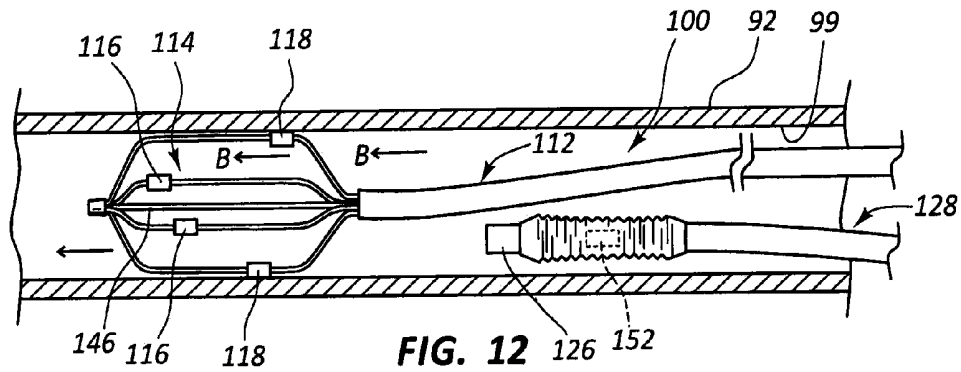

FIG. 12

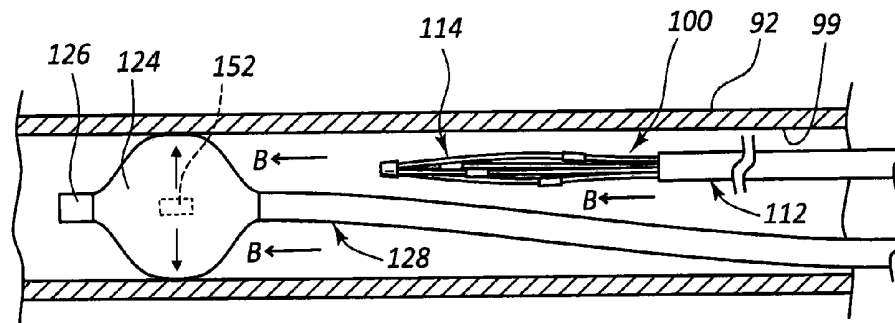

FIG. 13

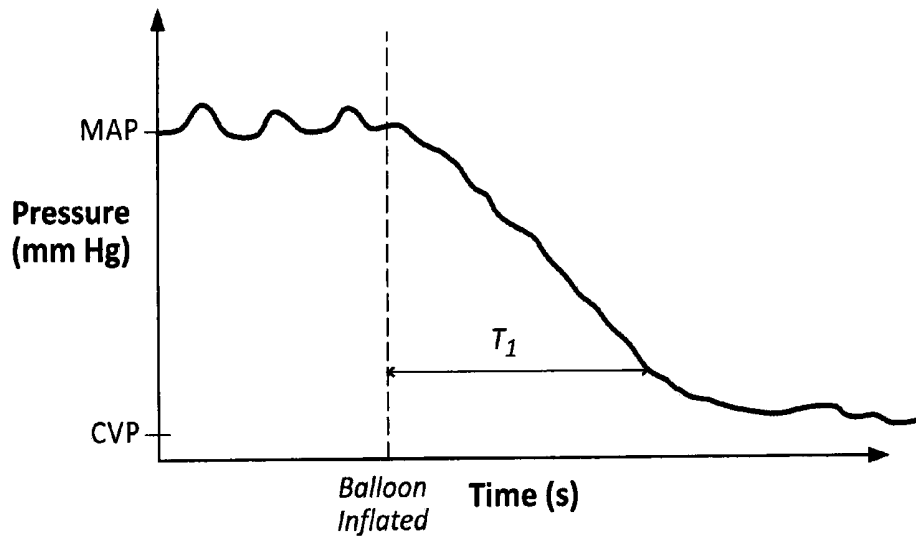

FIG. 14A

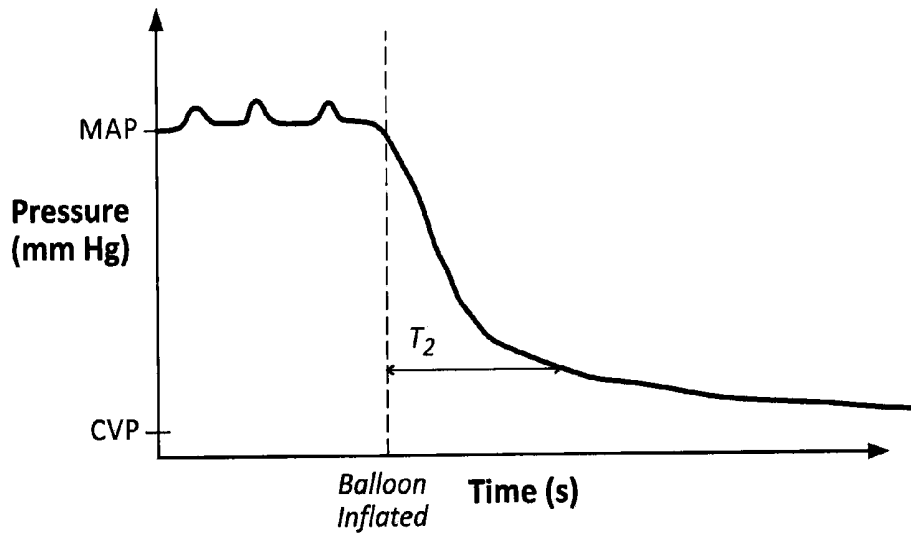

FIG. 14B

FEEDBACK SYSTEMS AND METHODS FOR RENAL DENERVATION UTILIZING BALLOON CATHETER

TECHNICAL FIELD

[0001] The present disclosure relates generally to renal denervation system and methods, and more particularly, to systems and methods for assessing the efficacy of a renal denervation procedure intraoperatively.

BACKGROUND

[0002] Renal denervation is a method whereby sympathetic nerve activity involving the targeted kidney is blocked or suppressed. Excessive sympathetic activity has been implicated in vasoconstriction, reduction in renal blood flow, retention of fluid and salt, elevated renin generation, over-activation of the renin-angiotension-aldosterone mechanism, increased catecholamine production and, ultimately, arterial hypertension. Thus, renal denervation is used to alter neural signaling mechanisms involving the kidney to treat hypertension and other related disorders.

[0003] Renal denervation is achieved through destruction of afferent and efferent nerve fibers that run adjacent to the renal arteries. Successful renal denervation results in lower systemic arterial blood pressure in a treated patient. Renal denervation has also been shown to have benefits in conjunction with current guideline-based treatment strategies in heart failure, diabetes, obesity, sleep apnea, and ventricular tachycardia (VT). A conventional renal denervation procedure involves introducing a radiofrequency (RF) ablation catheter, which ablates renal nerves at various locations using variable energy. Ideally, the operator's objective is to ablate as minimally as necessary to achieve an appropriate degree of renal denervation for the least amount of time and at the fewest locations. In order to achieve it, there is a need for feedback mechanisms to provide the operator with insight about the efficacy of the renal denervation treatment during the treatment procedure. This feedback would enable the operator to decide whether additional power, duration, and/or ablation locations are needed to accomplish adequate renal denervation.

SUMMARY

[0004] One aspect of the present disclosure relates to a renal denervation system, which includes a renal ablation catheter and an inflation balloon. The renal ablation catheter is insertable into a renal artery to perform a renal denervation procedure. The inflation balloon is inflatable within the renal artery, wherein a blood pressure condition in the renal artery resulting from operation of the inflation balloon and a performance characteristic of the inflation balloon indicates the efficacy of the renal denervation procedure.

[0005] The inflated balloon may block blood flow through the renal artery temporarily, and the blood pressure condition is assessed at a location distal of the inflation balloon (e.g., between the inflation balloon and the kidney) with a blood pressure measurement sensor. The blood pressure condition may be measured before and after ablating the renal artery in order to detect if there is a change in blood pressure condition. The blood pressure condition assessment includes a rate of decay of the blood pressure after blood occlusion due to balloon inflation. Another blood pressure condition assessment includes a time period required to

inflate the inflation balloon. The time period required to inflate the balloon to reach a pressure threshold may relate to the degree of vasodilation in the renal artery. The renal denervation catheter and the inflation balloon may be separately insertable into the renal artery.

[0006] Another aspect of the present disclosure relates to a method of determining efficacy of a renal denervation procedure in a renal artery. The method includes providing a renal denervation catheter and a inflation balloon, filling the inflation balloon within the renal artery to stop blood flow and measuring one of a blood pressure condition in the renal artery and a performance characteristic of the inflation balloon prior to performing the renal denervation procedure to obtain a first measurement, then filling the inflation balloon within the renal artery to stop blood flow and measuring the one of a blood pressure condition in the renal artery and a performance characteristic of the inflation balloon after performing the renal denervation procedure to obtain a second measurement, and comparing the first and second measurements to determine the efficacy of the renal denervation procedure.

[0007] The blood pressure condition may include a decay of the blood pressure condition upon deflating the inflation balloon. Measuring the blood pressure condition may include positioning a pressure sensor distal of the balloon (e.g., between the inflation balloon and the kidney). The performance characteristic of the inflation balloon may include an inflation rate of the inflation balloon. The performance characteristic of the inflation balloon may include an amount of time to inflate the inflation balloon to a predetermined pressure level. A reduction in the amount of time may correlate with unloading of sympathetic tone from the renal artery.

[0008] A further aspect of the present disclosure relates to a method of determining the efficacy of a renal denervation procedure in a renal artery. The method includes providing a renal denervation catheter and a inflation balloon, measuring a first amount of time to fill the inflation balloon within the renal artery, performing a first renal denervation procedure in the renal artery with the renal denervation catheter, after performing the first renal denervation procedure, measuring a second amount of time to fill the inflation balloon within the renal artery, and comparing the first and second amounts of time to determine the efficacy of the first renal denervation procedure.

[0009] Filling the inflation balloon may include filling the inflation balloon to a predetermined pressure level. The method may include axially moving the renal denervation catheter within the renal artery, performing a second renal denervation procedure, after performing the second renal denervation procedure, measuring a third amount of time to fill the inflation balloon, and comparing the third amount of time to at least one of the first and second amounts of time to determine efficacy of the second renal denervation procedure.

[0010] Another aspect of the present disclosure relates to a method of determining efficacy of a renal denervation procedure in a renal artery. The method includes providing a renal denervation catheter and a inflation balloon, inflating the inflation balloon to block blood flow through the renal artery and measuring a first rate of decay of blood pressure in the renal artery, deflating the inflation balloon, performing a first renal denervation procedure in the renal artery with the renal denervation catheter, after performing the renal

denervation procedure, inflating the inflation balloon to block blood flow through the renal artery and measuring a second rate of decay of blood pressure in the renal artery, and comparing the first and second rates of decay of blood pressure to determine efficacy of the first renal denervation procedure.

[0011] The renal denervation catheter may include a plurality of ablation members, and the method may include positioning the inflation balloon distal of the plurality of ablation members prior to filling the inflation balloon. The method may include providing the renal denervation catheter and inflation balloon on a common delivery device. The method may include performing a second renal denervation procedure after comparing the rates of decay of blood pressure, after performing the second renal denervation procedure, filling the inflation balloon to block blood flow through the renal artery and measuring a third rate of decay of blood pressure in the renal artery, and comparing the third rates of decay of blood pressure with at least one of the first and second rates of decay of blood pressure to determine efficacy of the second renal denervation procedure.

[0012] The foregoing and other features, utilities, and advantages of the invention will be apparent from the following detailed description of the invention with reference to the accompanying drawings.

BRIEF DESCRIPTION OF THE DRAWINGS

[0013] The accompanying drawings illustrate various embodiments of the present disclosure and are a part of the specification. The illustrated embodiments are merely examples of the present disclosure and do not limit the scope of the invention.

[0014] FIG. 1 is a perspective view of an example renal denervation catheter in accordance with the present disclosure.

[0015] FIG. 2 is a perspective view of the renal denervation catheter of FIG. 1 in a deployed position.

[0016] FIG. 3 shows the renal denervation catheter of FIG. 1 positioned in a renal artery.

[0017] FIG. 4 shows the renal denervation catheter of FIG. 3 with an inflation balloon inflated to block blood flow through the renal artery.

[0018] FIG. 5 shows the renal denervation catheter of FIG. 4 with the balloon in a deflated position.

[0019] FIG. 6 shows the renal denervation catheter of FIG. 5 in a deployed position within the renal artery.

[0020] FIG. 7 shows the renal denervation catheter of FIG. 6 in a contracted position and the balloon reinflated to block blood flow through the renal catheter.

[0021] FIG. 8 shows the renal denervation catheter of FIG. 7 with the balloon deflated.

[0022] FIG. 9 shows another example renal denervation catheter in accordance with the present disclosure.

[0023] FIG. 10 shows another example renal denervation catheter and a separate balloon catheter positioned in a renal artery in accordance with the present disclosure.

[0024] FIG. 11 shows the renal denervation catheter and balloon catheter of FIG. 10 with the balloon inflated to block blood flow within the renal artery.

[0025] FIG. 12 shows the renal denervation catheter and balloon catheter of FIG. 11 with the balloon deflated and withdrawn and the renal denervation catheter in a deployed position.

[0026] FIG. 13 shows the renal denervation catheter and balloon catheter of FIG. 12 with the renal denervation catheter in a contracted position and the balloon catheter advanced with the balloon inflated to block blood flow through the renal artery.

[0027] FIGS. 14A and 14B are graphs showing pressure decay within the renal artery distal of an inflated balloon before and after a renal denervation procedure, respectively.

[0028] Throughout the drawings, identical reference numbers designate similar, but not necessarily identical, elements.

DETAILED DESCRIPTION

[0029] The systems and methods disclosed herein are directed to aspects of renal denervation in a patient. The principles disclosed herein may be applicable to other systems and methods used for treating other aspects of the body, including, for example, any portion of the gastrointestinal, cardiovascular, nervous, hormonal, respiratory, excretory and reproductive systems of the body.

[0030] Renal denervation includes ablation of the renal artery using an ablation catheter. While not meant to be limiting, the systems and methods disclosed herein are used to provide feedback to an operator concerning the efficacy of the renal denervation procedure. The feedback may be given during the procedure, such as after ablating the renal artery while the ablation catheter remains positioned within the renal artery. It will be appreciated that the systems and methods disclosed herein may be applicable to other ablation procedures that disrupt innervation.

[0031] The general structure and function of renal denervation catheters (also referred to as renal ablation catheters) used for ablating tissue in the renal artery are well known in the art. The principles disclosed herein may be useful in conjunction with various renal denervation catheters and methods of conducting renal denervation procedures. One procedure for renal denervation includes introducing a radio frequency ablation catheter into the renal artery and ablating renal nerves at several locations using variable energy up to, for example, about 8 Watts. The locations may be determined by a plurality of pre-positioned ablation members arranged in contact with an interior surface of the renal artery at various axially and circumferentially spaced apart locations. In other examples, a single ablation member is moved to a plurality of positions within the renal artery to ablate the renal nerves. Typically, the renal denervation procedure includes inserting the ablation catheter into the aorta retrograde to the junction with the renal artery, and then advanced the ablation catheter into the renal artery. The anatomic terms "distal" (meaning further into the renal artery) and "proximal" (meaning less far into the renal artery) are used herein to describe relative positions within the renal artery.

[0032] The renal denervation catheters of the present disclosure may provide feedback mechanisms for determining the efficacy of the procedure while the procedure is ongoing, or at least while the renal denervation device is positioned within the patient. In one example, the feedback mechanism includes determining a rate of blood flow or a change in blood flow rate through the renal artery and correlating attributes of the blood flow to efficacy of the procedure. The feedback mechanisms may provide real-time feedback to an operator while a renal denervation catheter is positioned within the renal artery. The feedback mechanism

may provide information to the operator prior to and after each ablation takes place. For example, the renal denervation catheter may be positioned at one axial location along the length of the renal artery where a first set of ablations of the denervation procedure occur. The feedback mechanism may provide feedback to the operator concerning the efficacy of the first set of ablations. If the feedback indicates that insufficient ablation has occurred, the operator may move the renal denervation catheter in an axial direction along the length of renal artery and perform a second set of ablations, or may leave the renal denervation catheter in the same location and apply additional energy for further ablation. The feedback mechanism may provide additional feedback concerning efficacy of the second set of ablations. Thereafter, the operator may determine whether any additional ablation may be needed.

[0033] The renal denervation devices and methods disclosed herein utilize an inflation balloon, which is operable within the renal artery to temporarily stop blood flow without causing adverse hemodynamic effects. The inflation balloon may be an independent unit insertable into the renal artery. Alternatively, the balloon may be embedded in the body of the ablation catheter or in the body of a delivery catheter for the procedure. In a first method, a pressure sensor is positioned distal or downstream of the balloon (e.g., between the balloon and the kidney) to monitor blood pressure. After the balloon is inflated, the pressure sensor measures the decrease in blood pressure as blood passes to the glomerular apparatus and tubules of the kidney. This decrease in blood pressure may be referred to as pressure decay or exponential decay of blood pressure. Determinants of the exponential decay of blood pressure when the inflation balloon is inflated include the resistance of small arterioles and capillaries of the kidney, which prevents immediate outflow of all blood and capacitance of the renal artery and tributaries, which deflate as pressure is reduced. These two properties may be estimated using the profile of decaying blood pressure when the inflation balloon is inflated. Material properties of the vessels are unlikely to change over a short time scale, so the one way to alter the shape of the exponential decay is by altering renal vascular resistance, which is maintained under neural control. One purpose of the ablation is to relax renal vascular resistance, and may be titrated by measuring the change in the time constant of the exponential curve, which is typically directly proportional to the renal vascular resistance. A change in renal vascular resistance may be calculated by comparing time constant of exponential decay curve before and after ablation. The blood pressure measured before and after inflating the balloon may be plotted on a first graph. An increase in the rate of blood pressure decay may be used as a marker of successful denervation.

[0034] The balloon may then be deflated and the patient may be treated with at least one ablation member as part of a denervation procedure. Thereafter, the operator may reinflate the balloon and again measure the pressure decay. The pressure decay may be plotted on a second graph. Differences in the pressure decay before and after the denervation procedure may correspond to efficacy of the ablation.

[0035] A successful ablation typically reduces sympathetic vessel tone distal or downstream (e.g., toward the kidney) of the ablation site. The reduction in sympathetic vessel tone tends to decrease resistance to renal blood flow, which brings about a more rapid decrease in blood pressure

downstream of the inflated balloon. Comparing the rate of pressure decrease before and after the denervation procedure may provide a reasonable indication of the success of the denervation procedure. The operator may then determine whether additional ablation is needed. The pressure decay may be measured after each ablation.

[0036] In another example method, the balloon positioned within the renal artery is inflated to a predetermined pressure level. The time required to obtain the pressure level within the balloon may correlate to sympathetic tone in the renal artery. A renal artery that has been treated with a denervation procedure typically has less sympathetic tone, thereby permitting the balloon to inflate at a faster rate to reach the predetermined pressure level. Comparing the amount of time required to inflate the balloon to a desired pressure level prior to and after a denervation procedure may provide an indication to the operator of the efficacy of the renal denervation procedure. The operator may determine, based at least in part on feedback related to the change in the amount of time required to inflate the balloon, whether additional ablation is needed. A shortening of balloon inflation time may be used as a marker of successful denervation. The balloon may be inflated after each set of ablations to provide additional feedback to the operator concerning the efficacy of the denervation procedure.

[0037] In the examples described above, the inflation balloon may be integrated into a renal denervation catheter. Alternatively, the balloon may be carried by a separate balloon catheter that is operable independent of the denervation catheter. The balloon catheter may be advanced and withdrawn within the renal artery and relative to the denervation catheter as needed in order to obtain the desired feedback prior to and after performing ablation with the denervation catheter.

[0038] Referring now to FIGS. 1 and 2, an example renal denervation catheter 10 is shown including a catheter shaft 12, a deployable basket 14, ablation electrodes 16, 18, a controller 20, a hub 22, a balloon 24, and a pressure sensor 26. The deployable basket 14 is positioned at a distal end of the catheter shaft 12. The ablation electrodes 16, 18 are mounted to the deployable basket 14. The hub 22 is positioned at a proximal end of the catheter shaft 12. The balloon 24 may be mounted directly to the catheter shaft, such as at a proximal end portion of the catheter shaft 12. The pressure sensor 26 is typically positioned distal of the balloon 24, such as at a distal tip of the deployable basket 14.

[0039] The catheter shaft 12 includes distal and proximal ends 30, 32, and a lumen 34. The deployable basket 14 includes a plurality of splines 40A-D, distal and proximal ends 42, 44, and a pull wire 46. The pull wire 46 may extend through the lumen 34 of the catheter shaft 12. Applying an axially force to the pull wire 46 may move the deployable basket 14 from a retracted position as shown in FIG. 1 to a deployed position as shown in FIG. 2.

[0040] The ablation electrodes 16, 18 may be mounted individually to the splines 40A-D. The ablation electrodes 16 may be referred to as distal electrodes and the ablation electrodes 18 may be referred to as proximal electrodes. The ablation electrodes 16, 18 are typically spaced apart axially along the length of the renal denervation catheter 10 and positioned spaced apart circumferentially when the deployable basket 14 is in a deployed position of FIG. 2. Many other arrangements are possible for the deployable basket 14 and ablation electrodes carried thereon. Different numbers

of ablation electrodes and different numbers of splines may be used in other embodiments.

[0041] The ablation electrodes 16, 18 may include radio frequency (RF) electrodes. In other embodiments, the ablation electrodes 16, 18 may include other types of energy sources such as, for example, ultrasound, laser, cryothermal, and microwave energy sources.

[0042] The controller 20 may communicate with various features of the renal denervation catheter 10 such as, for example, the ablation electrodes 16, 18. The controller 20 may control the amount of energy delivered to the ablation electrodes 16, 18, the on/off state of the ablation electrodes 16, 18, and collect data provided by the ablation electrodes 16, 18 such as, for example, a temperature reading or a power level. The controller 20 may be electrically coupled to the ablation electrodes 16, 18 and other features such as, for example, the pressure sensor 26.

[0043] The pressure sensor 26 may be mounted at any location distal of the balloon 24. The pressure sensor 26 may be mounted to the deployable basket 14. In the example of FIGS. 1-8, the pressure sensor 26 is mounted to the distal end 42 of the deployable basket 14. FIG. 9 shows another example in which the pressure sensor 26 is mounted to the distal end 30 of the catheter shaft 12.

[0044] The hub 22 may include a pass-through opening that is connected in fluid communication with lumen 34 of the catheter shaft 12. The pull wire 46 may extend through the hub 22 where the pull wire 46 is exposed for operation by the operator. The pull wire 46 may be coupled to an actuating member (not shown) such as, for example, a lever or trigger that provides easier operation. The hub 22 may also include an inflation port 50. The inflation port 50 may be connected to a source of inflation fluid, which is delivered to the balloon 24. In at least some examples, the catheter shaft 12 includes a dedicated inflation lumen coupled in fluid communication with the balloon 24 and the inflation port 50. In other examples, the inflation fluid flows through the lumen 34. The lumen 34 includes sealing members that provide a sealed connection with the pull wire 46 to limit fluid flow out through the distal and proximal ends of the catheter shaft 12.

[0045] Referring to FIGS. 3-8, an example method of renal denervation is shown and described. FIG. 3 shows the renal denervation catheter 10 inserted through an aorta 90 and into a renal artery 92. The renal artery 92 provides blood flow to kidney 94. A plurality of renal nerves 96 may extend along an exterior of the renal artery 92 and may be positioned in and on a side wall of the renal artery 92. The renal artery 92 may have an inner surface 99 and may have an ostium 98 leading from the aorta 90.

[0046] In an initial step of the renal denervation procedure, the renal denervation catheter 10 may be inserted into the renal artery 92 to position the deployable basket 14 adjacent to the ostium 98. The deployable basket 14 may be operated into a deployed position to contact the ablation electrodes 16, 18 in contact with the inner surface 99 of the renal artery 92. The ablation electrodes 16, 18 or other features of the renal denervation catheter 10 may be operated to provide electrical stimulus of the renal nerves 96 (e.g., via control by controller 20 shown in FIG. 4). The electrical stimulus may produce a physiological response in the kidney 94 such as, for example, increased production of certain fluids and chemicals such as rennin. The physiological response of the kidney 94 may be measurable. This measured response may

be compared to the physiological response to the kidney 94 being electrically stimulated after completion of the renal denervation procedure.

[0047] Referring again to FIG. 3, the deployable basket 14 is contracted and the renal denervation catheter 10 is further advanced into the renal artery 92. The pressure sensor 26 may begin to measure the blood pressure within renal artery 92. The blood pressure may be plotted on a graph such as the graph shown in FIG. 14A. The blood pressure within the renal artery 92 may be calculated as a mean arterial pressure (MAP).

[0048] Referring now to FIG. 4, the balloon 24 may be inflated to stop the blood flow B at a location proximal of the pressure sensor 26. Blood in the renal artery 92 distal of the inflated balloon 24 passes to the glomerular apparatus and tubules of the kidney 94 resulting in a reduction in blood pressure. The decrease in renal artery blood pressure distal of the inflated balloon 24 may be modeled as an exponential decay from MAP as shown in FIG. 14A. The blood pressure eventually reaches an asymptotic value or central venous pressure (CVP). A time T_1 to complete a percentage of the transition from MAP to CVP is determined using, for example, the controller 20. In one example, the percentage used for determining time T_1 is in the range of about 50% to about 75%, and more particularly in the range of about 60% to about 65%. A sigmoidal function or other appropriate choice of curve may be used as a model of the decrease in blood pressure as part of comparing how the rate of decrease in blood pressure changes as a result of the denervation procedure.

[0049] Referring to FIG. 5, the balloon 24 is deflated and blood flow B is reinitiated in the renal artery 92. Referring to FIG. 6, the deployable basket 14 is deployed to contact the ablation electrodes 16, 18 against the inner surface 99 of the renal artery 92. Power is supplied to the ablation electrodes 16, 18 to ablate the renal artery 92, thereby providing denervation of the renal nerves 96. The pressure sensor 26 may continue to measure the blood pressure during and after completion of the ablation.

[0050] Referring to FIG. 7, the balloon 24 may be re-inflated to stop the blood flow B in the renal artery 92. The deployable basket 14 may remain in the deployed position shown in FIG. 6 while the balloon 24 is re-inflated. Alternatively, the deployable basket 14 may be contracted as shown in FIG. 7 while the balloon 24 is re-inflated. The pressure measurements taken by pressure sensor 26 may be plotted on a graph as shown in FIG. 14B after completion of the denervation described with reference to FIG. 6 and prior to and after re-inflating the balloon 24. A time T_2 to reach a percentage of the transition from MAP to CVP (e.g., about 63.2%) may be determined using, for example, the controller 20. The time T_2 may be compared to the time T_1 . If the difference between time T_2 and time T_1 (e.g., ΔT) is within a predetermined range, or the time T_2 reaches a predetermined threshold level, the denervation procedure described with reference to FIG. 6 may be considered successful. If the ΔT or value of T_2 is outside of a desired range or does not reach a predetermined value, respectively, the operator may choose to conduct additional ablation.

[0051] In one example, the operator deflates the balloon 24, repositions the deployable basket 14 at a different axial position along the renal artery 92, and then further ablates the renal nerves with the ablation electrodes 16, 18. Thereafter, the balloon 24 is re-inflated and the pressure sensor 26

supplies a downstream pressure measurement so that an additional pressure decay curve may be plotted in a graph comparable to the graphs shown in FIGS. 14A and 14B. A time T_3 to reach a percentage of the transition from MAP to CVP is determined and compared to the time T_1 and/or time T_2 to determine whether sufficient denervation has occurred.

[0052] The pattern of determining a pressure decay curve, evaluating the ΔT and/or absolute value of T_2 or T_3 , and performing denervation via ablation with ablation electrodes 16, 18 may continue until the operator concludes that sufficient denervation has occurred.

[0053] In general, if the pressure decay is sufficiently different after an ablation is performed and/or is indicative of a dilated vessel, the renal denervation procedure may be stopped. Otherwise, another site may be ablated or more energy applied at the same ablation site. The time constant of pressure decay may be a quantitative, acutely changing metric that provides real-time feedback for titration of renal artery ablation. The time constants of contralateral renal arteries may also be compared simultaneously.

[0054] Referring now to FIGS. 10-13, another example renal denervation system is shown and described. The renal denervation system includes a renal denervation catheter 100 and a balloon catheter 128, which together may be referred to as a renal denervation system. The renal denervation catheter 100 includes a catheter shaft 112, a deployable basket 114, ablation electrodes 116, 118, a controller 120, and a hub 122. The balloon catheter 128 includes a balloon 124 and a pressure sensor 126. The renal denervation catheter 100 and balloon catheter 128 may be operable independent of each other. For example, the renal denervation catheter 100 may be advanced into and removed from the renal artery 92 independent of advancing and withdrawing the balloon catheter 128.

[0055] Referring to FIG. 10, the balloon catheter 128 and renal denervation catheter 100 may be advanced into the renal artery 92, with the balloon 124 positioned distal of the deployable basket 114. The pressure sensor 126 may be positioned on the balloon catheter 128 at a location distal of the balloon 124 so that the pressure sensor 126 is arranged downstream of the balloon 124 when inflated.

[0056] Referring to FIG. 11, the balloon 124 is inflated to block blood flow B through the renal artery 92. The pressure sensor 126 may collect blood pressure measurements prior to and after inflating the balloon 124. The measurements from pressure sensor 126 may be plotted on a graph such as the graph shown in FIG. 14A. A time T_1 may be determined for completion of a percentage of the transition from MAP to CVP (e.g., about 63.2%).

[0057] Referring to FIG. 12, the balloon 124 is deflated and the balloon catheter 128 is withdrawn to position the balloon 124 proximal of the deployable basket 114. Alternatively, the renal denervation catheter 100 may be advanced while the balloon catheter 128 maintains a constant axial position. The deployable basket 114 may be operated into a deployed position using a pull wire 146 to contact the ablation electrodes 116, 118 against an inner surface 99 of the renal artery 92. The ablation electrodes 116, 118 are operated to ablate the renal nerves 96 associated with the renal artery 92. The controller 120 may operate to control operation of at least the ablation electrodes 116, 118. Blood flow B may continue after deflating the balloon 124 and during and after the denervation procedure.

[0058] Referring to FIG. 13, the balloon 24 may be positioned distal of the deployable basket 114 and then inflated to stop the blood flow B. The pressure sensor 126 may determine blood pressure at a location distal of the balloon 124 prior to and after inflation of balloon 124. The measurements from pressure sensor 126 may be plotted on a graph such as the graph shown in FIG. 14B. A time T_2 to reach a percentage of the transition from MAP to CVP (e.g., about 63%) may be determined and compared to the time T_1 . If the ΔT between T_2 and T_1 is within a predetermined range, or the value of T_2 reaches a threshold value, the renal denervation procedure may be stopped. If the ΔT is outside of a certain range, or the absolute value of T_2 does not meet the threshold level, the operator may choose to perform additional ablation and denervation.

[0059] The steps shown and described with reference to FIGS. 10-13 may be repeated as needed until a desired ΔT is reached. The renal denervation catheter 100 and balloon catheter 128 may be advanced and withdrawn axially as needed in order to position the balloon 124 at a location where blood flow B is stopped when a balloon 124 is inflated.

[0060] As mentioned above, in some examples, rather than using ΔT as the primary indicator of efficacy of the denervation procedure, an absolute value for T may be used. For example, a value of T less than 5 seconds may indicate sufficient denervation has occurred.

[0061] Referring again to FIGS. 3-8, another example method of renal denervation is described using the renal denervation catheter 10. The renal denervation catheter 10 may be operable in this method without the use of pressure sensor 26. According to this method, an amount of time required to fill the balloon 24 to a predetermined pressure is used to determine sympathetic tone in the renal artery 92, which may correlate with efficacy of a renal denervation procedure. Referring to FIG. 3, the renal denervation catheter 10 may be positioned within the renal artery 92. FIG. 4 shows the balloon 24 inflated. The time required to fill the balloon 24 to a predetermined pressure, size or shape is measured. In one example, a balloon sensor 52 may be used to determine the pressure within balloon 24. The balloon sensor 52 may be positioned within balloon 24 or may be positioned at any desired location along the flow path of the inflation fluid used to fill balloon 24. In one example, the balloon sensor 52 is associated with the source of inflation fluid, which is connected to the inflation port 50 of the hub 22.

[0062] Referring to FIG. 5, the balloon 24 is deflated and the renal denervation catheter 10 is operated to deploy the deployable basket 14 to contact the ablation electrodes 16, 18 against the inner surface 99 of the renal artery 92. The ablation electrodes 16, 18 are operated to ablate the renal nerves 96 associated with the renal artery 92. After completing the ablation, the balloon 24 is reinflated as shown in FIG. 7. An amount of time required to fill the balloon 24 (e.g., reach a threshold pressure condition within balloon 24 or achieve a certain size or shape) is determined and compared to the amount of time required to fill the balloon 24 prior to ablation. If the denervation procedure achieved its therapeutic aim of unloading sympathetic tone from the renal arterioles and capillaries, the resistive portion of the vascular impedance will decrease, while the material elasticity of the renal artery 92 will not change substantially. If the renal denervation procedure is effective and vasodilation

ensues, the time to inflate the balloon **24** decreases. The balloon **24** may be inflated and a time recorded prior to the procedure and then again after each ablation at various sites along the renal artery. If the time to fill the balloon **24** decreases sufficiently after ablation (e.g., a ΔT within a predetermined range), the renal denervation procedure may be stopped. Alternatively, as mentioned above, an absolute value for T may be used to determine whether sufficient denervation has occurred. If the operator determines additional denervation is required, another site may be ablated or more energy may be applied at the same ablation site. As shown in FIG. 8, the balloon **24** may eventually be deflated, the deployable basket **14** contracted, and the renal denervation catheter **100** removed from the renal artery **92**.

[0063] Referring again to FIGS. 10-13, the renal denervation catheter **100** and balloon catheter **128** may be used to determine the efficacy of a renal denervation procedure based on the amount of time required to fill the balloon **124**. The renal denervation catheter **100** and balloon catheter **128** may be positioned in the renal artery **92** as shown in FIG. 10. The balloon **124** is inflated prior to ablation using the renal denervation catheter **100**. The time required to inflate the balloon **124** to a predetermined pressure is determined as shown in FIG. 11. The pressure conditioned within balloon **124** may be determined using a balloon sensor **152**. Alternatively, other devices and methods may be used to determine whether a size, shape or other feature or characteristic of the balloon has been achieved. Thereafter, the balloon **124** is deflated and the balloon catheter **128** is positioned proximal of the deployable basket **114**. The renal denervation catheter **100** is operated to ablate the renal artery **92**.

[0064] After the ablation, the balloon **124** is again positioned distal of the renal denervation catheter **100** and inflated. The time required to inflate the balloon **124** to a predetermined pressure or to reach a desired shape or size is determined and compared to the time required to fill the balloon **124** prior to the denervation procedure (e.g., determination of ΔT). If the amount of time required to fill the balloon **124** to the predetermined pressure decreases a sufficient amount or is completed in a predetermined time period, the operator may stop the renal denervation procedure and remove the renal denervation catheter **100** and balloon catheter **128** from the renal artery **92**. Otherwise, another site may be ablated or more energy may be applied to the same ablation site to conduct further denervation. Thereafter, the balloon **124** is again inflated and the time required to fill the balloon **124** is compared to at least one of the times required to fill the balloon previously (e.g., before or after previous ablations).

[0065] The methods of determining efficacy of a renal denervation procedure using the time required to fill a balloon described above may be based primarily on vascular impedance. Vascular impedance presents as a resistance, determined primarily by a sympathetic tone, along with a portion that depends on vascular distention as a function of fluid volume and the elastic material properties of the containing vessels. Successful renal denervation may change vascular impedance.

[0066] The amount of time required to fill the inflation balloon may be referred to as a performance characteristic of the balloon. Other performance characteristics of the balloon may be used as an indicator of vascular impedance or other characteristics of the renal artery such as sympathetic tone.

[0067] As used in this specification and the appended claims, the terms “engage” and “engagable” are used broadly to mean interlock, mesh, or contact between two structures or devices. A “tube” is an elongated device with a passageway. A “lumen” refers to any open space or cavity in a bodily organ, especially in a blood vessel. The words “including” and “having,” as well as their derivatives, as used in the specification, including the claims, have the same meaning as the word “comprising.”

[0068] The preceding description has been presented only to illustrate and describe exemplary embodiments of the invention. It is not intended to be exhaustive or to limit the invention to any precise form disclosed. Many modifications and variations are possible in light of the above teaching. It is intended that the scope of the invention be defined by the following claims.

1-47. (canceled)

48. A method of determining efficacy of a renal denervation procedure in a renal artery, comprising:

providing a renal denervation catheter and an inflation balloon;

measuring a first amount of time to fill the inflation balloon within the renal artery;

deflating the inflation balloon;

performing a first renal denervation procedure in the renal artery with the renal denervation catheter;

after performing the renal denervation procedure, measuring a second amount of time to fill the inflation balloon within the renal artery;

comparing the first and second amounts of time to determine a change in the first and second amounts of time; and

determining that the efficacy of the first renal denervation procedure is sufficient when the change in the first and second amounts of time is within a predetermined range.

49. The method of claim 48, wherein measuring the first amount of time to fill the inflation balloon includes measuring the first amount of time to fill the inflation balloon to a predetermined pressure level.

50. The method of claim 48, further comprising:

determining that the efficacy of the first renal denervation procedure is insufficient when the change in the first and second amounts of time is not within the predetermined range;

axially moving the renal denervation catheter within the renal artery;

performing a second renal denervation procedure;

after performing the second renal denervation procedure, measuring a third amount of time to fill the inflation balloon; and

comparing the third amount of time with at least one of the first and second amounts of time to determine efficacy of the second renal denervation procedure.

51. The method of claim 50, wherein comparing the third amount of time with at least one of the first and second amounts of time comprises comparing the first and third amounts of time to determine a change in the first and third amounts of time, the method further comprising determining that the efficacy of the second renal denervation procedure is sufficient when the change in the first and third amounts of time is within the predetermined range.

52. The method of claim 50, wherein comparing the third amount of time with at least one of the first and second

amounts of time comprises comparing the second and third amounts of time to determine a change in the second and third amounts of time, the method further comprising determining that the efficacy of the second renal denervation procedure is sufficient when the change in the second and third amounts of time is within another predetermined range.

53. The method of claim **48**, further comprising positioning a balloon sensor in the inflation balloon, wherein measuring the first amount of time comprises measuring the first amount of time using the balloon sensor, and wherein measuring the second amount of time comprises measuring the second amount of time using the balloon sensor.

54. The method of claim **48**, wherein the change between the first amount of time and the second amount of time correlates to unloading of sympathetic tone from the renal artery.

55. The method of claim **48**, wherein measuring the first amount of time to fill the inflation balloon includes measuring the first amount of time to fill the inflation balloon to a predetermined size.

56. The method of claim **48** further comprising removing the renal denervation catheter and the inflation balloon from the renal artery after determining that the efficacy of the first renal denervation procedure is sufficient.

57. The method of claim **48** further comprising providing the renal denervation catheter and inflation balloon on a common delivery device.

58. A renal denervation system, comprising:

an ablation catheter insertable into a renal artery to perform a renal denervation procedure including ablating a renal artery;

an inflation balloon inflatable within the renal artery, wherein a performance characteristic of the inflation balloon indicates efficacy of the renal denervation procedure, wherein the performance characteristic of the inflation balloon includes an amount of time to fill the inflation balloon, wherein a first amount of time to fill the inflation balloon is measured before ablating the renal artery and a second amount of time to fill the inflation balloon is measured after ablating the renal artery to detect a change in the first and second amounts of time.

59. The renal denervation system of claim **58**, wherein the first amount of time to fill the inflation balloon includes the first amount of time to fill the inflation balloon to a predetermined pressure level.

60. The renal denervation system of claim **58** further comprising a balloon sensor within the inflation balloon, wherein the balloon sensor is configured to measure the first amount of time and the second amount of time.

61. The renal denervation system of claim **58**, wherein the change between the first amount of time and the second amount of time correlates to unloading of sympathetic tone from the renal artery.

62. The renal denervation system of claim **58**, wherein the first amount of time to fill the inflation balloon includes the first amount of time to fill the inflation balloon to a predetermined size.

63. The renal denervation system of claim **58**, wherein the renal denervation catheter and the inflation balloon are coupled to a common delivery device.

64. An inflation balloon configured to be inflated within a renal artery as part of a renal denervation procedure including ablating the renal artery, wherein a performance characteristic of the inflation balloon indicates efficacy of the renal denervation procedure, wherein the performance characteristic of the inflation balloon includes an amount of time to fill the inflation balloon, wherein a first amount of time to fill the inflation balloon is measured before ablating the renal artery and a second amount of time to fill the inflation balloon is measured after ablating the renal artery to detect a change in the first and second amounts of time.

65. The inflation balloon of claim **64**, wherein the first amount of time to fill the inflation balloon includes the first amount of time to fill the inflation balloon to a predetermined pressure level.

66. The inflation balloon of claim **64** further comprising a balloon sensor within the inflation balloon, wherein the balloon sensor is configured to measure the first amount of time and the second amount of time.

67. The inflation balloon of claim **64**, wherein the first amount of time to fill the inflation balloon includes the first amount of time to fill the inflation balloon to a predetermined size.

* * * * *

专利名称(译)	利用球囊导管进行肾去神经支配的反馈系统和方法		
公开(公告)号	US20160331451A1	公开(公告)日	2016-11-17
申请号	US15/219991	申请日	2016-07-26
[标]申请(专利权)人(译)	圣犹达医疗用品心脏病学部门有限公司		
申请(专利权)人(译)	ST.犹达医疗用品, 心脏病DIVISION, INC.		
当前申请(专利权)人(译)	ST.犹达医疗用品, 心脏病DIVISION, INC.		
[标]发明人	NABUTOVSKY YELENA KARST EDWARD QU FUJIAN		
发明人	NABUTOVSKY, YELENA KARST, EDWARD QU, FUJIAN		
IPC分类号	A61B18/14 A61B5/0215 A61B5/00		
CPC分类号	A61B18/1492 A61B5/6853 A61B5/0215 A61B2018/00404 A61B2018/00577 A61B2018/00511 A61B2018/00761 A61B2018/00267 A61B18/18 A61B2018/0022 A61B2018/00285 A61B2018/00434 A61B2018/00505 A61B2018/00642 A61B2018/00744 A61B2018/00773 A61B2018/00863 A61B2090/064		
其他公开文献	US9713494		
外部链接	Espacenet USPTO		

摘要(译)

肾去神经系统包括消融导管和充气气囊。肾去神经导管可插入肾动脉中以进行肾去神经支配术。充气气囊在肾动脉内是可膨胀的，其中由充气气囊的操作引起的肾动脉中的血压状况和充气气囊的性能特征之一指示肾去神经支配手术的功效。

