



US010561330B2

(12) **United States Patent**
Kharam et al.

(10) **Patent No.:** **US 10,561,330 B2**
(45) **Date of Patent:** **Feb. 18, 2020**

(54) **IMPLANTABLE MEDICAL DEVICE HAVING A SENSE CHANNEL WITH PERFORMANCE ADJUSTMENT**

(58) **Field of Classification Search**
CPC A61B 2560/0209; A61B 5/0402; A61B 5/0456; A61B 5/686; A61B 5/7203;
(Continued)

(71) Applicant: **CARDIAC PACEMAKERS, INC.**, St. Paul, MN (US)

(56) **References Cited**

(72) Inventors: **Aleksandra Kharam**, Maple Grove, MN (US); **Ron A. Balczewski**, Bloomington, MN (US); **Paul Huelskamp**, St. Paul, MN (US); **Lance Eric Juffer**, Lino Lakes, MN (US); **Keith R. Maile**, New Brighton, MN (US)

U.S. PATENT DOCUMENTS

3,835,864 A 9/1974 Rasor et al.
3,943,936 A 3/1976 Rasor et al.
(Continued)

(73) Assignee: **CARDIAC PACEMAKERS, INC.**, St. Paul, MN (US)

FOREIGN PATENT DOCUMENTS

AU 2008279789 B2 10/2011
AU 2008329620 B2 5/2014
(Continued)

(*) Notice: Subject to any disclaimer, the term of this patent is extended or adjusted under 35 U.S.C. 154(b) by 114 days.

OTHER PUBLICATIONS

US 8,886,318 B2, 11/2014, Jacobson et al. (withdrawn)
(Continued)

(21) Appl. No.: **15/792,353**

Primary Examiner — George Manuel

(22) Filed: **Oct. 24, 2017**

(74) *Attorney, Agent, or Firm* — Seager, Tufte & Wickhem LLP.

(65) **Prior Publication Data**

(57) **ABSTRACT**

US 2018/0116540 A1 May 3, 2018

An implantable medical device (IMD) may include a sensor for providing a sensor output signal and a sense channel configured to receive the sensor output signal from the sensor. The sense channel may be configured to process the sensor output signal and output a sense channel output signal. The sense channel may have an adjustable performance level, wherein for a higher performance level the sense channel consumes more power than for a lower performance level. A controller may be configured to adjust the performance level of the sense channel to achieve more performance and more power consumption when a higher degree of sense channel performance is desired and to achieve less performance and less power consumption when a higher degree of performance is not desired.

Related U.S. Application Data

(60) Provisional application No. 62/413,726, filed on Oct. 27, 2016.

(51) **Int. Cl.**
A61B 5/0402 (2006.01)
A61B 5/0456 (2006.01)
(Continued)

(52) **U.S. Cl.**
CPC **A61B 5/0456** (2013.01); **A61B 5/0402** (2013.01); **A61B 5/686** (2013.01);
(Continued)

20 Claims, 11 Drawing Sheets

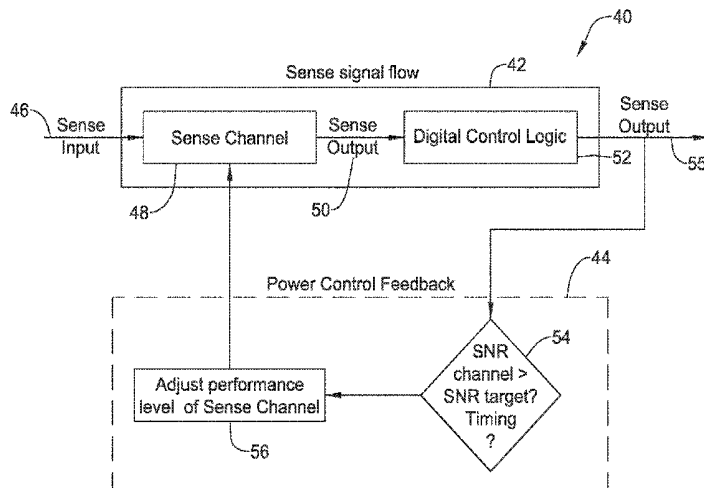

(51)	Int. Cl.		5,179,945 A	1/1993	Van Hofwegen et al.
	<i>A61N 1/372</i>	(2006.01)	5,193,539 A	3/1993	Schulman et al.
	<i>A61N 1/37</i>	(2006.01)	5,193,540 A	3/1993	Schulman et al.
	<i>A61N 1/378</i>	(2006.01)	5,241,961 A	9/1993	Henry
	<i>A61N 1/375</i>	(2006.01)	5,243,977 A	9/1993	Trabucco et al.
	<i>A61B 5/00</i>	(2006.01)	5,259,387 A	11/1993	DePinto
(52)	U.S. Cl.		5,269,326 A	12/1993	Verrier
	CPC	<i>A61B 5/7203</i> (2013.01); <i>A61B 5/7221</i>	5,284,136 A	2/1994	Hauck et al.
		(2013.01); <i>A61N 1/3704</i> (2013.01); <i>A61N</i>	5,300,107 A	4/1994	Stokes et al.
		<i>1/3708</i> (2013.01); <i>A61N 1/378</i> (2013.01);	5,301,677 A	4/1994	Hsung
		<i>A61N 1/3756</i> (2013.01); <i>A61N 1/37205</i>	5,305,760 A	4/1994	McKown et al.
		(2013.01); <i>A61N 1/37252</i> (2013.01); <i>A61N</i>	5,312,439 A	5/1994	Loeb
		<i>1/37512</i> (2017.08); <i>A61B 2560/0209</i> (2013.01)	5,313,953 A	5/1994	Yomtov et al.
(58)	Field of Classification Search		5,314,459 A	5/1994	Swanson et al.
	CPC ..	<i>A61B 5/7221</i> ; <i>A61N 1/3704</i> ; <i>A61N 1/3708</i> ;	5,318,597 A	6/1994	Hauck et al.
		<i>A61N 1/37205</i> ; <i>A61N 1/37252</i> ; <i>A61N</i>	5,324,316 A	6/1994	Schulman et al.
		<i>1/37512</i> ; <i>A61N 1/3756</i> ; <i>A61N 1/378</i>	5,331,966 A	7/1994	Bennett et al.
	See application file for complete search history.		5,334,222 A	8/1994	Salo et al.
(56)	References Cited		5,342,408 A	8/1994	deCoriolis et al.
	U.S. PATENT DOCUMENTS		5,370,667 A	12/1994	Alt
			5,372,606 A	12/1994	Lang et al.
			5,376,106 A	12/1994	Stahmann et al.
			5,383,915 A	1/1995	Adams
			5,388,578 A	2/1995	Yomtov et al.
			5,404,877 A	4/1995	Nolan et al.
			5,405,367 A	4/1995	Schulman et al.
			5,411,031 A	5/1995	Yomtov
			5,411,525 A	5/1995	Swanson et al.
			5,411,535 A	5/1995	Fujii et al.
			5,456,691 A	10/1995	Snell
			5,458,622 A	10/1995	Alt
			5,466,246 A	11/1995	Silvian
			5,468,254 A	11/1995	Hahn et al.
			5,472,453 A	12/1995	Alt
			5,522,866 A	6/1996	Fernald
			5,540,727 A	7/1996	Tockman et al.
			5,545,186 A	8/1996	Olson et al.
			5,545,202 A	8/1996	Dahl et al.
			5,571,146 A	11/1996	Jones et al.
			5,591,214 A	1/1997	Lu
			5,620,466 A	4/1997	Haefner et al.
			5,634,938 A	6/1997	Swanson et al.
			5,649,968 A	7/1997	Alt et al.
			5,662,688 A	9/1997	Haefner et al.
			5,674,259 A	10/1997	Gray
			5,683,426 A	11/1997	Greenhut et al.
			5,683,432 A	11/1997	Goedeke et al.
			5,706,823 A	1/1998	Wodlinger
			5,709,215 A	1/1998	Perttu et al.
			5,720,770 A	2/1998	Nappholz et al.
			5,728,154 A	3/1998	Crossett et al.
			5,741,314 A	4/1998	Daly et al.
			5,741,315 A	4/1998	Lee et al.
			5,752,976 A	5/1998	Duffin et al.
			5,752,977 A	5/1998	Grevious et al.
			5,755,736 A	5/1998	Gillberg et al.
			5,759,199 A	6/1998	Snell et al.
			5,774,501 A	6/1998	Halpern et al.
			5,792,195 A	8/1998	Carlson et al.
			5,792,202 A	8/1998	Rueter
			5,792,203 A	8/1998	Schroepfel
			5,792,205 A	8/1998	Alt et al.
			5,792,208 A	8/1998	Gray
			5,814,089 A	9/1998	Stokes et al.
			5,827,216 A	10/1998	Igo et al.
			5,836,985 A	11/1998	Rostami et al.
			5,836,987 A	11/1998	Baumann et al.
			5,842,977 A	12/1998	Lesho et al.
			5,855,593 A	1/1999	Olson et al.
			5,861,009 A	1/1999	Armstrong et al.
			5,873,894 A	2/1999	Vandegriff et al.
			5,891,184 A	4/1999	Lee et al.
			5,897,586 A	4/1999	Molina
			5,899,876 A	5/1999	Flower
			5,899,928 A	5/1999	Sholder et al.
			5,919,214 A	7/1999	Ciciarelli et al.
			5,935,078 A	8/1999	Feierbach
			5,941,906 A	8/1999	Barreras, Sr. et al.
			5,944,744 A	8/1999	Paul et al.

(56)

References Cited

U.S. PATENT DOCUMENTS

5,954,757	A	9/1999	Gray	6,440,066	B1	8/2002	Bardy
5,978,713	A	11/1999	Prutchi et al.	6,441,747	B1	8/2002	Khair et al.
5,991,660	A	11/1999	Goyal	6,442,426	B1	8/2002	Kroll
5,991,661	A	11/1999	Park et al.	6,442,432	B2	8/2002	Lee
5,999,848	A	12/1999	Gord et al.	6,443,891	B1	9/2002	Grevious
5,999,857	A	12/1999	Weijand et al.	6,445,953	B1	9/2002	Bulkes et al.
6,016,445	A	1/2000	Baura	6,453,200	B1	9/2002	Koslar
6,026,320	A	2/2000	Carlson et al.	6,459,929	B1	10/2002	Hopper et al.
6,029,085	A	2/2000	Olson et al.	6,470,215	B1	10/2002	Kraus et al.
6,041,250	A	3/2000	DePinto	6,471,645	B1	10/2002	Warkentin et al.
6,044,298	A	3/2000	Salo et al.	6,480,745	B2	11/2002	Nelson et al.
6,044,300	A	3/2000	Gray	6,487,443	B2	11/2002	Olson et al.
6,055,454	A	4/2000	Heemels	6,490,487	B1	12/2002	Kraus et al.
6,073,050	A	6/2000	Griffith	6,498,951	B1	12/2002	Larson et al.
6,076,016	A	6/2000	Feierbach	6,507,755	B1	1/2003	Gozani et al.
6,077,236	A	6/2000	Cunningham	6,507,759	B1	1/2003	Prutchi et al.
6,080,187	A	6/2000	Alt et al.	6,512,940	B1	1/2003	Brabec et al.
6,083,248	A	7/2000	Thompson	6,522,915	B1	2/2003	Ceballos et al.
6,106,551	A	8/2000	Crossett et al.	6,526,311	B2	2/2003	Begemann
6,115,636	A	9/2000	Ryan	6,539,253	B2	3/2003	Thompson et al.
6,128,526	A	10/2000	Stadler et al.	6,542,775	B2	4/2003	Ding et al.
6,141,581	A	10/2000	Olson et al.	6,553,258	B2	4/2003	Stahmann et al.
6,141,583	A	10/2000	Pape et al.	6,561,975	B1	5/2003	Pool et al.
6,141,588	A	10/2000	Cox et al.	6,564,807	B1	5/2003	Schulman et al.
6,141,592	A	10/2000	Pauly	6,574,506	B2	6/2003	Kramer et al.
6,144,879	A	11/2000	Gray	6,584,351	B1	6/2003	Ekwall
6,162,195	A	12/2000	Igo et al.	6,584,352	B2	6/2003	Combs et al.
6,164,284	A	12/2000	Schulman et al.	6,597,948	B1	7/2003	Rockwell et al.
6,167,303	A	* 12/2000	Thompson A61N 1/378 607/2	6,597,951	B2	7/2003	Kramer et al.
6,167,310	A	12/2000	Grevious	6,622,045	B2	9/2003	Snell et al.
6,201,993	B1	3/2001	Kruse et al.	6,622,046	B2	9/2003	Fraley et al.
6,208,894	B1	3/2001	Schulman et al.	6,628,985	B2	9/2003	Sweeney et al.
6,211,799	B1	4/2001	Post et al.	6,647,292	B1	11/2003	Bardy et al.
6,221,011	B1	4/2001	Bardy	6,666,844	B1	12/2003	Igo et al.
6,240,316	B1	5/2001	Richmond et al.	6,689,117	B2	2/2004	Sweeney et al.
6,240,317	B1	5/2001	Villaseca et al.	6,690,959	B2	2/2004	Thompson
6,256,534	B1	7/2001	Dahl	6,694,189	B2	2/2004	Begemann
6,259,947	B1	7/2001	Olson et al.	6,704,602	B2	3/2004	Berg et al.
6,266,558	B1	7/2001	Gozani et al.	6,718,212	B2	4/2004	Parry et al.
6,266,567	B1	7/2001	Ishikawa et al.	6,721,597	B1	4/2004	Bardy et al.
6,270,457	B1	8/2001	Bardy	6,738,670	B1	5/2004	Almendinger et al.
6,272,377	B1	8/2001	Sweeney et al.	6,746,797	B2	6/2004	Benson et al.
6,273,856	B1	8/2001	Sun et al.	6,749,566	B2	6/2004	Russ
6,277,072	B1	8/2001	Bardy	6,758,810	B2	7/2004	Lebel et al.
6,280,380	B1	8/2001	Bardy	6,763,269	B2	7/2004	Cox
6,285,907	B1	9/2001	Kramer et al.	6,778,860	B2	8/2004	Ostroff et al.
6,292,698	B1	9/2001	Duffin et al.	6,788,971	B1	9/2004	Sloman et al.
6,295,473	B1	9/2001	Rosar	6,788,974	B2	9/2004	Bardy et al.
6,297,943	B1	10/2001	Carson	6,804,558	B2	10/2004	Haller et al.
6,298,271	B1	10/2001	Weijand	6,807,442	B1	10/2004	Myklebust et al.
6,307,751	B1	10/2001	Bodony et al.	6,847,844	B2	1/2005	Sun et al.
6,312,378	B1	11/2001	Bardy	6,871,095	B2	3/2005	Stahmann et al.
6,315,721	B2	11/2001	Schulman et al.	6,878,112	B2	4/2005	Linberg et al.
6,336,903	B1	1/2002	Bardy	6,885,889	B2	4/2005	Chinchoy
6,345,202	B2	2/2002	Richmond et al.	6,892,094	B2	5/2005	Ousdigian et al.
6,351,667	B1	2/2002	Godie	6,897,788	B2	5/2005	Khair et al.
6,351,669	B1	2/2002	Hartley et al.	6,904,315	B2	6/2005	Panken et al.
6,353,759	B1	3/2002	Hartley et al.	6,922,592	B2	7/2005	Thompson et al.
6,358,203	B2	3/2002	Bardy	6,931,282	B2	8/2005	Esler
6,361,780	B1	3/2002	Ley et al.	6,934,585	B1	8/2005	Schloss et al.
6,366,812	B1	4/2002	Levine et al.	6,957,107	B2	10/2005	Rogers et al.
6,368,284	B1	4/2002	Bardy	6,978,176	B2	12/2005	Latouf
6,371,922	B1	4/2002	Baumann et al.	6,985,773	B2	1/2006	Von Arx et al.
6,398,728	B1	6/2002	Bardy	6,990,375	B2	1/2006	Kloss et al.
6,400,982	B2	6/2002	Sweeney et al.	7,001,366	B2	2/2006	Ballard
6,400,990	B1	6/2002	Silvian	7,003,350	B2	2/2006	Denker et al.
6,408,208	B1	6/2002	Sun	7,006,864	B2	2/2006	Echt et al.
6,409,674	B1	6/2002	Brockway et al.	7,013,178	B2	3/2006	Reinke et al.
6,411,848	B2	6/2002	Kramer et al.	7,027,871	B2	4/2006	Burnes et al.
6,424,865	B1	7/2002	Ding	7,050,849	B2	5/2006	Echt et al.
6,434,429	B1	8/2002	Kraus et al.	7,060,031	B2	6/2006	Webb et al.
6,438,410	B2	8/2002	Hsu et al.	7,063,693	B2	6/2006	Guenst
6,438,417	B1	8/2002	Rockwell et al.	7,082,336	B2	7/2006	Ransbury et al.
6,438,421	B1	8/2002	Stahmann et al.	7,085,606	B2	8/2006	Flach et al.
				7,092,758	B2	8/2006	Sun et al.
				7,110,824	B2	9/2006	Amundson et al.
				7,120,504	B2	10/2006	Osypka
				7,130,681	B2	10/2006	Gebhardt et al.
				7,139,613	B2	11/2006	Reinke et al.

(56)

References Cited

U.S. PATENT DOCUMENTS

7,142,912	B2	11/2006	Wagner et al.	7,616,991	B2	11/2009	Mann et al.
7,146,225	B2	12/2006	Guenst et al.	7,617,001	B2	11/2009	Penner et al.
7,146,226	B2	12/2006	Lau et al.	7,617,007	B2	11/2009	Williams et al.
7,149,581	B2	12/2006	Goedeke	7,630,767	B1	12/2009	Poore et al.
7,149,588	B2	12/2006	Lau et al.	7,634,313	B1	12/2009	Kroll et al.
7,158,839	B2	1/2007	Lau	7,637,867	B2	12/2009	Zdeblick
7,162,307	B2	1/2007	Patrias	7,640,060	B2	12/2009	Zdeblick
7,164,952	B2	1/2007	Lau et al.	7,647,109	B2	1/2010	Hastings et al.
7,177,700	B1	2/2007	Cox	7,650,186	B2	1/2010	Hastings et al.
7,181,505	B2	2/2007	Haller et al.	7,657,311	B2	2/2010	Bardy et al.
7,184,830	B2	2/2007	Echt et al.	7,668,596	B2	2/2010	Von Arx et al.
7,186,214	B2	3/2007	Ness	7,682,316	B2	3/2010	Anderson et al.
7,191,015	B2	3/2007	Lamson et al.	7,691,047	B2	4/2010	Ferrari
7,200,437	B1	4/2007	Nabutovsky et al.	7,702,392	B2	4/2010	Echt et al.
7,200,439	B2	4/2007	Zdeblick et al.	7,713,194	B2	5/2010	Zdeblick
7,206,423	B1	4/2007	Feng et al.	7,713,195	B2	5/2010	Zdeblick
7,209,785	B2	4/2007	Kim et al.	7,729,783	B2	6/2010	Michels et al.
7,209,790	B2	4/2007	Thompson et al.	7,734,333	B2	6/2010	Ghanem et al.
7,211,884	B1	5/2007	Davis et al.	7,734,343	B2	6/2010	Ransbury et al.
7,212,871	B1	5/2007	Morgan	7,738,958	B2	6/2010	Zdeblick et al.
7,226,440	B2	6/2007	Gelfand et al.	7,738,964	B2	6/2010	Von Arx et al.
7,228,183	B2	6/2007	Sun et al.	7,742,812	B2	6/2010	Ghanem et al.
7,236,821	B2	6/2007	Cates et al.	7,742,816	B2	6/2010	Masoud et al.
7,236,829	B1	6/2007	Farazi et al.	7,742,822	B2	6/2010	Masoud et al.
7,254,448	B2	8/2007	Almendinger et al.	7,743,151	B2	6/2010	Vallapureddy et al.
7,260,436	B2	8/2007	Kilgore et al.	7,747,335	B2	6/2010	Williams
7,270,669	B1	9/2007	Sra	7,751,881	B2	7/2010	Cowan et al.
7,272,448	B1	9/2007	Morgan et al.	7,758,521	B2	7/2010	Morris et al.
7,277,755	B1	10/2007	Falkenberg et al.	7,761,150	B2	7/2010	Ghanem et al.
7,280,872	B1	10/2007	Mosesov et al.	7,761,164	B2	7/2010	Verhoef et al.
7,288,096	B2	10/2007	Chin	7,765,001	B2	7/2010	Echt et al.
7,289,847	B1	10/2007	Gill et al.	7,769,452	B2	8/2010	Ghanem et al.
7,289,852	B2	10/2007	Helfinstine et al.	7,783,362	B2	8/2010	Whitehurst et al.
7,289,853	B1	10/2007	Campbell et al.	7,792,588	B2	9/2010	Harding
7,289,855	B2	10/2007	Nghiem et al.	7,797,059	B1	9/2010	Bornzin et al.
7,302,294	B2	11/2007	Kamath et al.	7,801,596	B2	9/2010	Fischell et al.
7,305,266	B1	12/2007	Kroll	7,809,438	B2	10/2010	Echt et al.
7,310,556	B2	12/2007	Bulkes	7,840,281	B2	11/2010	Kveen et al.
7,319,905	B1	1/2008	Morgan et al.	7,844,331	B2	11/2010	Li et al.
7,321,798	B2	1/2008	Muhlenberg et al.	7,844,348	B2	11/2010	Swoyer et al.
7,333,853	B2	2/2008	Mazar et al.	7,846,088	B2	12/2010	Ness
7,336,994	B2	2/2008	Hettrick et al.	7,848,815	B2	12/2010	Brisken et al.
7,345,607	B1	3/2008	Frigaard et al.	7,848,823	B2	12/2010	Drasler et al.
7,347,819	B2	3/2008	Lebel et al.	7,860,455	B2	12/2010	Fukumoto et al.
7,366,572	B2	4/2008	Heruth et al.	7,871,433	B2	1/2011	Lattouf
7,373,207	B2	5/2008	Lattouf	7,877,136	B1	1/2011	Moffitt et al.
7,384,403	B2	6/2008	Sherman	7,877,142	B2	1/2011	Moaddeb et al.
7,386,342	B1	6/2008	Falkenberg et al.	7,881,786	B2	2/2011	Jackson
7,392,090	B2	6/2008	Sweeney et al.	7,881,798	B2	2/2011	Miesel et al.
7,406,105	B2	7/2008	DelMain et al.	7,881,810	B1	2/2011	Chitre et al.
7,406,349	B2	7/2008	Seeberger et al.	7,890,173	B2	2/2011	Brisken et al.
7,410,497	B2	8/2008	Hastings et al.	7,890,181	B2	2/2011	Denzene et al.
7,425,200	B2	9/2008	Brockway et al.	7,890,192	B1	2/2011	Kelsch et al.
7,433,739	B1	10/2008	Salys et al.	7,894,885	B2	2/2011	Bartal et al.
7,496,409	B2	2/2009	Greenhut et al.	7,894,894	B2	2/2011	Stadler et al.
7,496,410	B2	2/2009	Heil	7,894,907	B2	2/2011	Cowan et al.
7,502,652	B2	3/2009	Gaunt et al.	7,894,910	B2	2/2011	Cowan et al.
7,512,448	B2	3/2009	Malick et al.	7,894,915	B1	2/2011	Chitre et al.
7,515,969	B2	4/2009	Tockman et al.	7,899,537	B1	3/2011	Kroll et al.
7,526,342	B2	4/2009	Chin et al.	7,899,541	B2	3/2011	Cowan et al.
7,529,589	B2	5/2009	Williams et al.	7,899,542	B2	3/2011	Cowan et al.
7,532,933	B2	5/2009	Hastings et al.	7,899,554	B2	3/2011	Williams et al.
7,536,222	B2	5/2009	Bardy et al.	7,901,360	B1	3/2011	Yang et al.
7,536,224	B2	5/2009	Ritscher et al.	7,904,170	B2	3/2011	Harding
7,539,541	B2	5/2009	Quiles et al.	7,907,993	B2	3/2011	Ghanem et al.
7,544,197	B2	6/2009	Kelsch et al.	7,920,928	B1	4/2011	Yang et al.
7,558,631	B2	7/2009	Cowan et al.	7,925,343	B1	4/2011	Min et al.
7,565,195	B1	7/2009	Kroll et al.	7,930,022	B2	4/2011	Zhang et al.
7,584,002	B2	9/2009	Burnes et al.	7,930,040	B1	4/2011	Kelsch et al.
7,590,455	B2	9/2009	Heruth et al.	7,937,135	B2	5/2011	Ghanem et al.
7,606,621	B2	10/2009	Brisken et al.	7,937,148	B2	5/2011	Jacobson
7,610,088	B2	10/2009	Chinchoy	7,937,161	B2	5/2011	Hastings et al.
7,610,092	B2	10/2009	Cowan et al.	7,941,214	B2	5/2011	Kleckner et al.
7,610,099	B2	10/2009	Almendinger et al.	7,945,333	B2	5/2011	Jacobson
7,610,104	B2	10/2009	Kaplan et al.	7,946,997	B2	5/2011	Hübinette
				7,949,404	B2	5/2011	Hill
				7,949,405	B2	5/2011	Feher
				7,953,486	B2	5/2011	Daum et al.
				7,953,493	B2	5/2011	Fowler et al.

(56)

References Cited

U.S. PATENT DOCUMENTS

7,962,202 B2	6/2011	Bhunia	8,340,780 B2	12/2012	Hastings et al.
7,974,702 B1	7/2011	Fain et al.	8,352,025 B2	1/2013	Jacobson
7,979,136 B2	7/2011	Young et al.	8,352,028 B2	1/2013	Wenger
7,983,753 B2	7/2011	Severin	8,352,038 B2	1/2013	Mao et al.
7,991,467 B2	8/2011	Markowitz et al.	8,359,098 B2	1/2013	Lund et al.
7,991,471 B2	8/2011	Ghanem et al.	8,364,261 B2	1/2013	Stubbs et al.
7,996,087 B2	8/2011	Cowan et al.	8,364,276 B2	1/2013	Willis
8,000,791 B2	8/2011	Sunagawa et al.	8,369,959 B2	2/2013	Meskens
8,000,807 B2	8/2011	Morris et al.	8,369,962 B2	2/2013	Abrahamson
8,001,975 B2	8/2011	DiSilvestro et al.	8,380,320 B2	2/2013	Spital
8,002,700 B2	8/2011	Ferek-Petric et al.	8,386,051 B2	2/2013	Rys
8,010,209 B2	8/2011	Jacobson	8,391,981 B2	3/2013	Mosesov
8,019,419 B1	9/2011	Panescu et al.	8,391,990 B2	3/2013	Smith et al.
8,019,434 B2	9/2011	Quiles et al.	8,406,874 B2	3/2013	Liu et al.
8,027,727 B2	9/2011	Freeberg	8,406,879 B2	3/2013	Shuros et al.
8,027,729 B2	9/2011	Sunagawa et al.	8,406,886 B2	3/2013	Gaunt et al.
8,032,219 B2	10/2011	Neumann et al.	8,412,352 B2	4/2013	Griswold et al.
8,036,743 B2	10/2011	Savage et al.	8,417,340 B2	4/2013	Goossen
8,046,079 B2	10/2011	Bange et al.	8,417,341 B2	4/2013	Freeberg
8,046,080 B2	10/2011	Von Arx et al.	8,423,149 B2	4/2013	Hennig
8,050,297 B2	11/2011	DelMain et al.	8,428,722 B2	4/2013	Verhoef et al.
8,050,759 B2	11/2011	Stegemann et al.	8,433,402 B2	4/2013	Ruben et al.
8,050,774 B2	11/2011	Kveen et al.	8,433,409 B2	4/2013	Johnson et al.
8,055,345 B2	11/2011	Li et al.	8,433,420 B2	4/2013	Bange et al.
8,055,350 B2	11/2011	Roberts	8,447,412 B2	5/2013	Dal Molin et al.
8,060,212 B1	11/2011	Rios et al.	8,452,413 B2	5/2013	Young et al.
8,065,018 B2	11/2011	Haubrich et al.	8,457,740 B2	6/2013	Osche
8,073,542 B2	12/2011	Doerr	8,457,742 B2	6/2013	Jacobson
8,078,278 B2	12/2011	Penner	8,457,744 B2	6/2013	Janzig et al.
8,078,283 B2	12/2011	Cowan et al.	8,457,761 B2	6/2013	Warior
8,095,123 B2	1/2012	Gray	8,478,407 B2	7/2013	Demmer et al.
8,102,789 B2	1/2012	Rosar et al.	8,478,408 B2	7/2013	Hastings et al.
8,103,359 B2	1/2012	Reddy	8,478,431 B2	7/2013	Griswold et al.
8,103,361 B2	1/2012	Moser	8,494,632 B2	7/2013	Sun et al.
8,112,148 B2	2/2012	Giffakis et al.	8,504,156 B2	8/2013	Bonner et al.
8,114,021 B2	2/2012	Robertson et al.	8,509,910 B2	8/2013	Sowder et al.
8,121,680 B2	2/2012	Falkenberg et al.	8,515,559 B2	8/2013	Roberts et al.
8,123,684 B2	2/2012	Zdeblick	8,525,340 B2	9/2013	Eckhardt et al.
8,126,545 B2	2/2012	Flach et al.	8,527,068 B2	9/2013	Ostroff
8,131,334 B2	3/2012	Lu et al.	8,532,790 B2	9/2013	Griswold
8,140,161 B2	3/2012	Willerton et al.	8,538,526 B2	9/2013	Stahmann et al.
8,150,521 B2	4/2012	Crowley et al.	8,541,131 B2	9/2013	Lund et al.
8,160,672 B2	4/2012	Kim et al.	8,543,205 B2	9/2013	Ostroff
8,160,702 B2	4/2012	Mann et al.	8,547,248 B2	10/2013	Zdeblick et al.
8,160,704 B2	4/2012	Freeberg	8,548,605 B2	10/2013	Ollivier
8,165,694 B2	4/2012	Carbanaru et al.	8,554,333 B2	10/2013	Wu et al.
8,175,715 B1	5/2012	Cox	8,565,882 B2	10/2013	Matos
8,180,451 B2	5/2012	Hickman et al.	8,565,897 B2	10/2013	Regnier et al.
8,185,213 B2	5/2012	Kveen et al.	8,571,678 B2	10/2013	Wang
8,187,161 B2	5/2012	Li et al.	8,577,327 B2	11/2013	Makdissi et al.
8,195,293 B2	6/2012	Limousin et al.	8,588,926 B2	11/2013	Moore et al.
8,204,595 B2	6/2012	Pianca et al.	8,612,002 B2	12/2013	Faltys et al.
8,204,605 B2	6/2012	Hastings et al.	8,615,310 B2	12/2013	Khairkahan et al.
8,209,014 B2	6/2012	Doerr	8,626,280 B2	1/2014	Allavatam et al.
8,214,043 B2	7/2012	Matos	8,626,294 B2	1/2014	Sheldon et al.
8,224,244 B2	7/2012	Kim et al.	8,634,908 B2	1/2014	Cowan
8,229,556 B2	7/2012	Li	8,634,912 B2	1/2014	Bornzin et al.
8,233,985 B2	7/2012	Bulkes et al.	8,634,919 B1	1/2014	Hou et al.
8,262,578 B1	9/2012	Bharmi et al.	8,639,335 B2	1/2014	Peichel et al.
8,265,748 B2	9/2012	Liu et al.	8,644,934 B2	2/2014	Hastings et al.
8,265,757 B2	9/2012	Mass et al.	8,649,859 B2	2/2014	Smith et al.
8,280,521 B2	10/2012	Haubrich et al.	8,670,842 B1	3/2014	Bornzin et al.
8,285,387 B2	10/2012	Utsi et al.	8,676,319 B2	3/2014	Knoll
8,290,598 B2	10/2012	Boon et al.	8,676,335 B2	3/2014	Katoozi et al.
8,290,600 B2	10/2012	Hastings et al.	8,694,097 B2*	4/2014	Cao A61N 1/3704
8,295,939 B2	10/2012	Jacobson			607/14
8,301,254 B2	10/2012	Mosesov et al.	8,700,173 B2	4/2014	Edlund
8,315,701 B2	11/2012	Cowan et al.	8,700,181 B2	4/2014	Bornzin et al.
8,315,708 B2	11/2012	Berthelsdorf et al.	8,705,599 B2	4/2014	dal Molin et al.
8,321,021 B2	11/2012	Kisker et al.	8,718,766 B2	5/2014	Wahlberg
8,321,036 B2	11/2012	Brockway et al.	8,718,773 B2	5/2014	Willis et al.
8,332,036 B2	12/2012	Hastings et al.	8,725,260 B2	5/2014	Shuros et al.
8,335,563 B2	12/2012	Stessman	8,738,133 B2	5/2014	Shuros et al.
8,335,568 B2	12/2012	Heruth et al.	8,738,147 B2	5/2014	Hastings et al.
8,340,750 B2	12/2012	Prakash et al.	8,744,555 B2	6/2014	Allavatam et al.
			8,744,572 B1	6/2014	Greenhut et al.
			8,747,314 B2	6/2014	Stahmann et al.
			8,755,884 B2	6/2014	Demmer et al.
			8,758,365 B2	6/2014	Bonner et al.

(56)

References Cited

U.S. PATENT DOCUMENTS

8,768,483	B2	7/2014	Schmitt et al.	9,399,139	B2	7/2016	Demmer et al.
8,774,572	B2	7/2014	Hamamoto	9,399,140	B2	7/2016	Cho et al.
8,781,605	B2	7/2014	Bornzin et al.	9,409,033	B2	8/2016	Jacobson
8,788,035	B2	7/2014	Jacobson	9,427,594	B1	8/2016	Bornzin et al.
8,788,053	B2	7/2014	Jacobson	9,433,368	B2	9/2016	Stahmann et al.
8,798,740	B2	8/2014	Samade et al.	9,433,780	B2	9/2016	Régnier et al.
8,798,745	B2	8/2014	Jacobson	9,457,193	B2	10/2016	Klimovitch et al.
8,798,762	B2	8/2014	Fain et al.	9,492,668	B2	11/2016	Sheldon et al.
8,798,770	B2	8/2014	Reddy	9,492,669	B2	11/2016	Demmer et al.
8,805,505	B1	8/2014	Roberts	9,492,674	B2	11/2016	Schmidt et al.
8,805,528	B2	8/2014	Corndorf	9,492,677	B2	11/2016	Greenhut et al.
8,812,109	B2	8/2014	Blomqvist et al.	9,511,233	B2	12/2016	Sambelashvili
8,818,504	B2	8/2014	Bodner et al.	9,511,236	B2	12/2016	Varady et al.
8,827,913	B2	9/2014	Havel et al.	9,511,237	B2	12/2016	Deterre et al.
8,831,747	B1	9/2014	Min et al.	9,522,276	B2	12/2016	Shen et al.
8,855,789	B2	10/2014	Jacobson	9,522,280	B2	12/2016	Fishler et al.
8,868,186	B2	10/2014	Kroll	9,526,522	B2	12/2016	Wood et al.
8,886,339	B2	11/2014	Faltys et al.	9,526,891	B2	12/2016	Eggen et al.
8,903,473	B2	12/2014	Rogers et al.	9,526,909	B2	12/2016	Stahmann et al.
8,903,500	B2	12/2014	Smith et al.	9,533,163	B2	1/2017	Klimovitch et al.
8,903,513	B2	12/2014	Ollivier	9,561,382	B2	2/2017	Persson et al.
8,909,336	B2	12/2014	Navarro-Paredes et al.	9,566,012	B2	2/2017	Greenhut et al.
8,914,131	B2	12/2014	Bornzin et al.	9,636,511	B2	5/2017	Carney et al.
8,923,795	B2	12/2014	Makdissi et al.	9,669,223	B2	6/2017	Auricchio et al.
8,923,963	B2	12/2014	Bonner et al.	9,687,654	B2	6/2017	Sheldon et al.
8,938,300	B2	1/2015	Rosero	9,687,655	B2	6/2017	Pertijs et al.
8,942,806	B2	1/2015	Sheldon et al.	9,687,659	B2	6/2017	Von Arx et al.
8,958,892	B2	2/2015	Khairkahan et al.	9,694,186	B2	7/2017	Carney et al.
8,977,358	B2	3/2015	Ewert et al.	9,782,594	B2	10/2017	Stahmann et al.
8,989,873	B2	3/2015	Locsin	9,782,601	B2	10/2017	Ludwig
8,996,109	B2	3/2015	Karst et al.	9,789,317	B2	10/2017	Greenhut et al.
9,002,467	B2	4/2015	Smith et al.	9,789,319	B2	10/2017	Sambelashvili
9,008,776	B2	4/2015	Cowan et al.	9,808,617	B2	11/2017	Ostroff et al.
9,008,777	B2	4/2015	Dianaty et al.	9,808,628	B2	11/2017	Sheldon et al.
9,014,818	B2	4/2015	Deterre et al.	9,808,631	B2	11/2017	Maile et al.
9,017,341	B2	4/2015	Bornzin et al.	9,808,632	B2	11/2017	Reinke et al.
9,020,611	B2	4/2015	Khairkahan et al.	9,808,633	B2	11/2017	Bonner et al.
9,037,262	B2	5/2015	Regnier et al.	9,808,637	B2	11/2017	Sharma et al.
9,042,984	B2	5/2015	Demmer et al.	9,855,414	B2	1/2018	Marshall et al.
9,072,911	B2	7/2015	Hastings et al.	9,855,430	B2	1/2018	Ghosh et al.
9,072,913	B2	7/2015	Jacobson	9,855,435	B2	1/2018	Sahabi et al.
9,155,882	B2	10/2015	Grubac et al.	9,861,815	B2	1/2018	Tran et al.
9,168,372	B2	10/2015	Fain	10,080,887	B2	9/2018	Schmidt et al.
9,168,380	B1	10/2015	Greenhut et al.	10,080,888	B2	9/2018	Kelly et al.
9,168,383	B2	10/2015	Jacobson et al.	10,080,900	B2	9/2018	Ghosh et al.
9,180,285	B2	11/2015	Moore et al.	10,080,903	B2	9/2018	Willis et al.
9,192,774	B2	11/2015	Jacobson	10,086,206	B2	10/2018	Sambelashvili
9,205,225	B2	12/2015	Khairkahan et al.	10,118,026	B2	11/2018	Grubac et al.
9,216,285	B1	12/2015	Boling et al.	10,124,163	B2	11/2018	Ollivier et al.
9,216,293	B2	12/2015	Berthiaume et al.	10,124,175	B2	11/2018	Berthiaume et al.
9,216,298	B2	12/2015	Jacobson	10,130,821	B2	11/2018	Grubac et al.
9,227,077	B2	1/2016	Jacobson	10,137,305	B2	11/2018	Kane et al.
9,238,145	B2	1/2016	Wenzel et al.	10,201,710	B2	2/2019	Jackson et al.
9,242,102	B2	1/2016	Khairkahan et al.	10,207,115	B2	2/2019	Echt et al.
9,242,113	B2	1/2016	Smith et al.	10,207,116	B2	2/2019	Sheldon et al.
9,248,300	B2	2/2016	Rys et al.	2002/0032470	A1	3/2002	Linberg
9,265,436	B2	2/2016	Min et al.	2002/0035376	A1	3/2002	Bardy et al.
9,265,962	B2	2/2016	Dianaty et al.	2002/0035377	A1	3/2002	Bardy et al.
9,272,155	B2	3/2016	Ostroff	2002/0035378	A1	3/2002	Bardy et al.
9,278,218	B2	3/2016	Karst et al.	2002/0035380	A1	3/2002	Rissmann et al.
9,278,229	B1	3/2016	Reinke et al.	2002/0035381	A1	3/2002	Bardy et al.
9,283,381	B2	3/2016	Grubac et al.	2002/0042629	A1	4/2002	Bardy et al.
9,283,382	B2	3/2016	Berthiaume et al.	2002/0042630	A1	4/2002	Bardy et al.
9,289,612	B1	3/2016	Sambelashvili et al.	2002/0042634	A1	4/2002	Bardy et al.
9,302,115	B2	4/2016	Molin et al.	2002/0049475	A1	4/2002	Bardy et al.
9,333,364	B2	5/2016	Echt et al.	2002/0052636	A1	5/2002	Bardy et al.
9,358,387	B2	6/2016	Suwito et al.	2002/0068958	A1	6/2002	Bardy et al.
9,358,400	B2	6/2016	Jacobson	2002/0072773	A1	6/2002	Bardy et al.
9,364,675	B2	6/2016	Deterre et al.	2002/0082665	A1	6/2002	Haller et al.
9,370,663	B2	6/2016	Moulder	2002/0091414	A1	7/2002	Bardy et al.
9,375,580	B2	6/2016	Bonner et al.	2002/0095196	A1	7/2002	Linberg
9,375,581	B2	6/2016	Baru et al.	2002/0099423	A1	7/2002	Berg et al.
9,381,365	B2	7/2016	Kibler et al.	2002/0103510	A1	8/2002	Bardy et al.
9,393,424	B2	7/2016	Demmer et al.	2002/0107545	A1	8/2002	Rissmann et al.
9,393,436	B2	7/2016	Doerr	2002/0107546	A1	8/2002	Ostroff et al.
				2002/0107547	A1	8/2002	Erlinger et al.
				2002/0107548	A1	8/2002	Bardy et al.
				2002/0107549	A1	8/2002	Bardy et al.
				2002/0107559	A1	8/2002	Sanders et al.

(56)

References Cited

U.S. PATENT DOCUMENTS

2002/0120299 A1	8/2002	Ostroff et al.	2006/0265018 A1	11/2006	Smith et al.
2002/0173830 A1	11/2002	Starkweather et al.	2007/0004979 A1	1/2007	Wojciechowicz et al.
2002/0193846 A1	12/2002	Pool et al.	2007/0016098 A1	1/2007	Kim et al.
2003/0009203 A1	1/2003	Lebel et al.	2007/0027508 A1	2/2007	Cowan
2003/0028082 A1	2/2003	Thompson	2007/0078490 A1	4/2007	Cowan et al.
2003/0040779 A1	2/2003	Engmark et al.	2007/0088394 A1	4/2007	Jacobson
2003/0041866 A1	3/2003	Linberg et al.	2007/0088396 A1	4/2007	Jacobson
2003/0045805 A1	3/2003	Sheldon et al.	2007/0088397 A1	4/2007	Jacobson
2003/0088278 A1	5/2003	Bardy et al.	2007/0088398 A1	4/2007	Jacobson
2003/0097153 A1	5/2003	Bardy et al.	2007/0088405 A1	4/2007	Jacobson
2003/0105497 A1	6/2003	Zhu et al.	2007/0135882 A1	6/2007	Drasler et al.
2003/0114908 A1	6/2003	Flach	2007/0135883 A1	6/2007	Drasler et al.
2003/0144701 A1	7/2003	Mehra et al.	2007/0150037 A1	6/2007	Hastings et al.
2003/0187460 A1	10/2003	Chin et al.	2007/0150038 A1	6/2007	Hastings et al.
2003/0187461 A1	10/2003	Chin	2007/0156190 A1	7/2007	Cinbis
2004/0024435 A1	2/2004	Leckrone et al.	2007/0219525 A1	9/2007	Gelfand et al.
2004/0068302 A1	4/2004	Rodgers et al.	2007/0219590 A1	9/2007	Hastings et al.
2004/0087938 A1	5/2004	Leckrone et al.	2007/0225545 A1	9/2007	Ferrari
2004/0088035 A1	5/2004	Guenst et al.	2007/0233206 A1	10/2007	Frikart et al.
2004/0102830 A1	5/2004	Williams	2007/0239244 A1	10/2007	Morgan et al.
2004/0127959 A1	7/2004	Amundson et al.	2007/0255376 A1	11/2007	Michels et al.
2004/0133242 A1	7/2004	Chapman et al.	2007/0276444 A1	11/2007	Gelbart et al.
2004/0147969 A1	7/2004	Mann et al.	2007/0293900 A1	12/2007	Sheldon et al.
2004/0147973 A1	7/2004	Hauser	2007/0293904 A1	12/2007	Gelbart et al.
2004/0167558 A1	8/2004	Igo et al.	2008/0004663 A1	1/2008	Jorgenson
2004/0167587 A1	8/2004	Thompson	2008/0021505 A1	1/2008	Hastings et al.
2004/0172071 A1	9/2004	Bardy et al.	2008/0021519 A1	1/2008	De Geest et al.
2004/0172077 A1	9/2004	Chinchoy	2008/0021532 A1	1/2008	Kveen et al.
2004/0172104 A1	9/2004	Berg et al.	2008/0065183 A1	3/2008	Whitehurst et al.
2004/0176817 A1	9/2004	Wahlstrand et al.	2008/0065185 A1	3/2008	Worley
2004/0176818 A1	9/2004	Wahlstrand et al.	2008/0071318 A1	3/2008	Brooke et al.
2004/0176830 A1	9/2004	Fang	2008/0109054 A1	5/2008	Hastings et al.
2004/0186529 A1	9/2004	Bardy et al.	2008/0119911 A1	5/2008	Rosero
2004/0204673 A1	10/2004	Flaherty	2008/0130670 A1	6/2008	Kim et al.
2004/0210292 A1	10/2004	Bardy et al.	2008/0154139 A1	6/2008	Shuros et al.
2004/0210293 A1	10/2004	Bardy et al.	2008/0154322 A1	6/2008	Jackson et al.
2004/0210294 A1	10/2004	Bardy et al.	2008/0228234 A1	9/2008	Stancer
2004/0215308 A1	10/2004	Bardy et al.	2008/0234771 A1	9/2008	Chinchoy et al.
2004/0220624 A1	11/2004	Ritscher et al.	2008/0243217 A1	10/2008	Wildon
2004/0220626 A1	11/2004	Wagner	2008/0269814 A1	10/2008	Rosero
2004/0220639 A1	11/2004	Mulligan et al.	2008/0269825 A1	10/2008	Chinchoy et al.
2004/0230283 A1	11/2004	Prinzen et al.	2008/0275518 A1	11/2008	Ghanem et al.
2004/0249431 A1	12/2004	Ransbury et al.	2008/0275519 A1	11/2008	Ghanem et al.
2004/0260348 A1	12/2004	Bakken et al.	2008/0288039 A1	11/2008	Reddy
2004/0267303 A1	12/2004	Guenst	2008/0294208 A1	11/2008	Willis et al.
2005/0061320 A1	3/2005	Lee et al.	2008/0294210 A1	11/2008	Rosero
2005/0070962 A1	3/2005	Echt et al.	2008/0294229 A1	11/2008	Friedman et al.
2005/0102003 A1	5/2005	Grabek et al.	2008/0306359 A1	12/2008	Zdeblick et al.
2005/0149138 A1	7/2005	Min et al.	2009/0018599 A1	1/2009	Hastings et al.
2005/0165466 A1	7/2005	Morris et al.	2009/0024180 A1	1/2009	Kisker et al.
2005/0182465 A1	8/2005	Ness	2009/0036941 A1	2/2009	Corbucci
2005/0203410 A1	9/2005	Jenkins	2009/0048646 A1	2/2009	Katoozi et al.
2005/0283208 A1	12/2005	Von Arx et al.	2009/0062895 A1	3/2009	Stahmann et al.
2005/0288743 A1	12/2005	Ahn et al.	2009/0082827 A1	3/2009	Kveen et al.
2006/0042830 A1	3/2006	Maghribi et al.	2009/0082828 A1	3/2009	Ostroff
2006/0052829 A1	3/2006	Sun et al.	2009/0088813 A1	4/2009	Brockway et al.
2006/0052830 A1	3/2006	Spinelli et al.	2009/0131907 A1	5/2009	Chin et al.
2006/0064135 A1	3/2006	Brockway	2009/0135886 A1	5/2009	Robertson et al.
2006/0064149 A1	3/2006	Belacazar et al.	2009/0143835 A1	6/2009	Pastore et al.
2006/0085039 A1	4/2006	Hastings et al.	2009/0171408 A1	7/2009	Solem
2006/0085041 A1	4/2006	Hastings et al.	2009/0171414 A1	7/2009	Kelly et al.
2006/0085042 A1	4/2006	Hastings et al.	2009/0204163 A1	8/2009	Shuros et al.
2006/0095078 A1	5/2006	Tronnes	2009/0204170 A1	8/2009	Hastings et al.
2006/0106442 A1	5/2006	Richardson et al.	2009/0210024 A1	8/2009	M.
2006/0116746 A1	6/2006	Chin	2009/0216292 A1	8/2009	Pless et al.
2006/0135999 A1	6/2006	Bodner et al.	2009/0234407 A1	9/2009	Hastings et al.
2006/0136004 A1	6/2006	Cowan et al.	2009/0234411 A1	9/2009	Sambelashvili et al.
2006/0161061 A1	7/2006	Echt et al.	2009/0266573 A1	10/2009	Engmark et al.
2006/0200002 A1	9/2006	Guenst	2009/0275998 A1	11/2009	Burnes et al.
2006/0206151 A1	9/2006	Lu	2009/0275999 A1	11/2009	Burnes et al.
2006/0212079 A1	9/2006	Routh et al.	2009/0299447 A1	12/2009	Jensen et al.
2006/0241701 A1	10/2006	Markowitz et al.	2010/0013668 A1	1/2010	Kantervik
2006/0241705 A1	10/2006	Neumann et al.	2010/0016911 A1	1/2010	Willis et al.
2006/0247672 A1	11/2006	Vidlund et al.	2010/0023085 A1	1/2010	Wu et al.
2006/0259088 A1	11/2006	Pastore et al.	2010/0030061 A1	2/2010	Canfield et al.
			2010/0030327 A1	2/2010	Chatel
			2010/0042108 A1	2/2010	Hibino
			2010/0056871 A1	3/2010	Govari et al.
			2010/0063375 A1	3/2010	Kassab et al.

(56)

References Cited

U.S. PATENT DOCUMENTS

2010/0063562	A1	3/2010	Cowan et al.	2012/0197373	A1	8/2012	Khairkhahan et al.
2010/0069983	A1	3/2010	Peacock, III et al.	2012/0215285	A1	8/2012	Tahmasian et al.
2010/0094367	A1	4/2010	Sen	2012/0232565	A1	9/2012	Kveen et al.
2010/0114209	A1	5/2010	Krause et al.	2012/0245665	A1	9/2012	Friedman et al.
2010/0114214	A1	5/2010	Morelli et al.	2012/0277600	A1	11/2012	Greenhut
2010/0125281	A1	5/2010	Jacobson et al.	2012/0277606	A1	11/2012	Ellingson et al.
2010/0168761	A1	7/2010	Kassab et al.	2012/0283795	A1	11/2012	Stancer et al.
2010/0168819	A1	7/2010	Freeberg	2012/0283807	A1	11/2012	Deterre et al.
2010/0198288	A1	8/2010	Ostroff	2012/0289776	A1	11/2012	Keast et al.
2010/0198304	A1	8/2010	Wang	2012/0289815	A1	11/2012	Keast et al.
2010/0217367	A1	8/2010	Belson	2012/0290021	A1	11/2012	Saurkar et al.
2010/0228308	A1	9/2010	Cowan et al.	2012/0290025	A1	11/2012	Keimel
2010/0234906	A1	9/2010	Koh	2012/0296381	A1	11/2012	Matos
2010/0234924	A1	9/2010	Willis	2012/0303082	A1	11/2012	Dong et al.
2010/0241185	A1	9/2010	Mahapatra et al.	2012/0316613	A1	12/2012	Keefe et al.
2010/0249729	A1	9/2010	Morris et al.	2013/0012151	A1	1/2013	Hankins
2010/0286744	A1	11/2010	Echt et al.	2013/0023975	A1	1/2013	Locsin
2010/0298841	A1	11/2010	Prinzen et al.	2013/0035748	A1	2/2013	Bonner et al.
2010/0312309	A1	12/2010	Harding	2013/0041422	A1	2/2013	Jacobson
2011/0022113	A1	1/2011	Zdeblick et al.	2013/0053908	A1	2/2013	Smith et al.
2011/0071586	A1	3/2011	Jacobson	2013/0053915	A1	2/2013	Holmstrom et al.
2011/0077708	A1	3/2011	Ostroff	2013/0053921	A1	2/2013	Bonner et al.
2011/0112600	A1	5/2011	Cowan et al.	2013/0060298	A1	3/2013	Splett et al.
2011/0118588	A1	5/2011	Komblau et al.	2013/0066169	A1	3/2013	Rys et al.
2011/0118810	A1	5/2011	Cowan et al.	2013/0072770	A1	3/2013	Rao et al.
2011/0137187	A1	6/2011	Yang et al.	2013/0079798	A1	3/2013	Tran et al.
2011/0144720	A1	6/2011	Cowan et al.	2013/0079861	A1	3/2013	Reinert et al.
2011/0152970	A1	6/2011	Jollota et al.	2013/0085350	A1	4/2013	Schugt et al.
2011/0160558	A1	6/2011	Rassatt et al.	2013/0085403	A1	4/2013	Gunderson et al.
2011/0160565	A1	6/2011	Stubbs et al.	2013/0085550	A1	4/2013	Polefko et al.
2011/0160801	A1	6/2011	Markowitz et al.	2013/0096649	A1	4/2013	Martin et al.
2011/0160806	A1	6/2011	Lyden et al.	2013/0103047	A1	4/2013	Steingisser et al.
2011/0166620	A1	7/2011	Cowan et al.	2013/0103109	A1	4/2013	Jacobson
2011/0166621	A1	7/2011	Cowan et al.	2013/0110008	A1	5/2013	Bourget et al.
2011/0184491	A1	7/2011	Kivi	2013/0110127	A1	5/2013	Bornzin et al.
2011/0190835	A1	8/2011	Brockway et al.	2013/0110192	A1	5/2013	Tran et al.
2011/0208260	A1	8/2011	Jacobson	2013/0110219	A1	5/2013	Bornzin et al.
2011/0218587	A1	9/2011	Jacobson	2013/0116529	A1	5/2013	Min et al.
2011/0230734	A1	9/2011	Fain et al.	2013/0116738	A1	5/2013	Samade et al.
2011/0237967	A1	9/2011	Moore et al.	2013/0116740	A1	5/2013	Bornzin et al.
2011/0245890	A1	10/2011	Brisben et al.	2013/0116741	A1	5/2013	Bornzin et al.
2011/0251660	A1	10/2011	Griswold	2013/0123872	A1	5/2013	Bornzin et al.
2011/0251662	A1	10/2011	Griswold et al.	2013/0123875	A1	5/2013	Varady et al.
2011/0270099	A1	11/2011	Ruben et al.	2013/0131591	A1	5/2013	Berthiaume et al.
2011/0270339	A1	11/2011	Murray, III et al.	2013/0131693	A1	5/2013	Berthiaume et al.
2011/0270340	A1	11/2011	Pellegrini et al.	2013/0138006	A1	5/2013	Bornzin et al.
2011/0270341	A1	11/2011	Ruben et al.	2013/0150695	A1	6/2013	Biela et al.
2011/0276102	A1	11/2011	Cohen	2013/0150911	A1	6/2013	Perschbacher et al.
2011/0282423	A1	11/2011	Jacobson	2013/0150912	A1	6/2013	Perschbacher et al.
2012/0004527	A1	1/2012	Thompson et al.	2013/0184776	A1	7/2013	Shuros et al.
2012/0029323	A1	2/2012	Zhao	2013/0192611	A1	8/2013	Taepke, II et al.
2012/0041508	A1	2/2012	Rouso et al.	2013/0196703	A1	8/2013	Masoud et al.
2012/0059433	A1	3/2012	Cowan et al.	2013/0197609	A1	8/2013	Moore et al.
2012/0059436	A1	3/2012	Fontaine et al.	2013/0231710	A1	9/2013	Jacobson
2012/0065500	A1	3/2012	Rogers et al.	2013/0238072	A1	9/2013	Deterre et al.
2012/0078322	A1	3/2012	Dal Molin et al.	2013/0238073	A1	9/2013	Makdissi et al.
2012/0089198	A1	4/2012	Ostroff	2013/0253309	A1	9/2013	Allan et al.
2012/0093245	A1	4/2012	Makdissi et al.	2013/0253342	A1	9/2013	Griswold et al.
2012/0095521	A1	4/2012	Hintz	2013/0253343	A1	9/2013	Waldhauser et al.
2012/0095539	A1	4/2012	Khairkhahan et al.	2013/0253344	A1	9/2013	Griswold et al.
2012/0101540	A1	4/2012	O'Brien et al.	2013/0253345	A1	9/2013	Griswold et al.
2012/0101553	A1	4/2012	Reddy	2013/0253346	A1	9/2013	Griswold et al.
2012/0109148	A1	5/2012	Bonner et al.	2013/0253347	A1	9/2013	Griswold et al.
2012/0109149	A1	5/2012	Bonner et al.	2013/0261497	A1	10/2013	Pertjjs et al.
2012/0109236	A1	5/2012	Jacobson et al.	2013/0265144	A1	10/2013	Banna et al.
2012/0109259	A1	5/2012	Bond et al.	2013/0268042	A1	10/2013	Hastings et al.
2012/0116489	A1	5/2012	Khairkhahan et al.	2013/0274828	A1	10/2013	Willis
2012/0150251	A1	6/2012	Giftakis et al.	2013/0274847	A1	10/2013	Ostroff
2012/0158111	A1	6/2012	Khairkhahan et al.	2013/0282070	A1	10/2013	Cowan et al.
2012/0165827	A1	6/2012	Khairkhahan et al.	2013/0282073	A1	10/2013	Cowan et al.
2012/0172690	A1	7/2012	Anderson et al.	2013/0296727	A1	11/2013	Sullivan et al.
2012/0172891	A1	7/2012	Lee	2013/0303872	A1	11/2013	Taff et al.
2012/0172892	A1	7/2012	Grubac et al.	2013/0324825	A1	12/2013	Ostroff et al.
2012/0172942	A1	7/2012	Berg	2013/0325081	A1	12/2013	Karst et al.
2012/0197350	A1	8/2012	Roberts et al.	2013/0345770	A1	12/2013	Dianaty et al.
				2014/0012344	A1	1/2014	Hastings et al.
				2014/0018876	A1	1/2014	Ostroff
				2014/0018877	A1	1/2014	Demmer et al.
				2014/0031836	A1	1/2014	Ollivier

(56)

References Cited

U.S. PATENT DOCUMENTS

2014/0039570 A1 2/2014 Carroll et al.
 2014/0039591 A1 2/2014 Drasler et al.
 2014/0043146 A1 2/2014 Makdissi et al.
 2014/0046395 A1 2/2014 Regnier et al.
 2014/0046420 A1 2/2014 Moore et al.
 2014/0058240 A1 2/2014 Mothilal et al.
 2014/0058494 A1 2/2014 Ostroff et al.
 2014/0074114 A1 3/2014 Khairkahan et al.
 2014/0074186 A1 3/2014 Faltys et al.
 2014/0094891 A1 4/2014 Pare et al.
 2014/0100624 A1 4/2014 Ellingson
 2014/0100627 A1 4/2014 Min
 2014/0107723 A1 4/2014 Hou et al.
 2014/0121719 A1 5/2014 Bonner et al.
 2014/0121720 A1 5/2014 Bonner et al.
 2014/0121722 A1 5/2014 Sheldon et al.
 2014/0128935 A1 5/2014 Kumar et al.
 2014/0135865 A1 5/2014 Hastings et al.
 2014/0142648 A1 5/2014 Smith et al.
 2014/0148675 A1 5/2014 Nordstrom et al.
 2014/0148815 A1 5/2014 Wenzel et al.
 2014/0155950 A1 6/2014 Hastings et al.
 2014/0169162 A1 6/2014 Romano et al.
 2014/0172060 A1 6/2014 Bornzin et al.
 2014/0180306 A1 6/2014 Grubac et al.
 2014/0180366 A1 6/2014 Edlund
 2014/0207149 A1 7/2014 Hastings et al.
 2014/0207210 A1 7/2014 Willis et al.
 2014/0214104 A1 7/2014 Greenhut et al.
 2014/0222015 A1 8/2014 Keast et al.
 2014/0222098 A1 8/2014 Baru et al.
 2014/0222109 A1 8/2014 Moulder
 2014/0228913 A1 8/2014 Molin et al.
 2014/0236172 A1 8/2014 Hastings et al.
 2014/0243848 A1 8/2014 Auricchio et al.
 2014/0255298 A1 9/2014 Cole et al.
 2014/0257324 A1 9/2014 Fain
 2014/0257422 A1 9/2014 Herken
 2014/0257444 A1 9/2014 Cole et al.
 2014/0276929 A1 9/2014 Foster et al.
 2014/0303704 A1 10/2014 Suwito et al.
 2014/0309706 A1 10/2014 Jacobson
 2014/0343348 A1 11/2014 Kaplan et al.
 2014/0371818 A1 12/2014 Bond et al.
 2014/0379041 A1 12/2014 Foster
 2015/0025612 A1 1/2015 Haasl et al.
 2015/0039041 A1 2/2015 Smith et al.
 2015/0045868 A1 2/2015 Bonner et al.
 2015/0051609 A1 2/2015 Schmidt et al.
 2015/0051610 A1 2/2015 Schmidt et al.
 2015/0051611 A1 2/2015 Schmidt et al.
 2015/0051612 A1 2/2015 Schmidt et al.
 2015/0051613 A1 2/2015 Schmidt et al.
 2015/0051614 A1 2/2015 Schmidt et al.
 2015/0051615 A1 2/2015 Schmidt et al.
 2015/0051616 A1 2/2015 Haasl et al.
 2015/0051682 A1 2/2015 Schmidt et al.
 2015/0057520 A1 2/2015 Foster et al.
 2015/0057558 A1 2/2015 Stahmann et al.
 2015/0057721 A1 2/2015 Stahmann et al.
 2015/0088155 A1 3/2015 Stahmann et al.
 2015/0105836 A1 4/2015 Bonner et al.
 2015/0126854 A1 5/2015 Keast et al.
 2015/0157861 A1 6/2015 Aghassian
 2015/0157866 A1 6/2015 Demmer et al.
 2015/0173655 A1 6/2015 Demmer et al.
 2015/0190638 A1 7/2015 Smith et al.
 2015/0196756 A1 7/2015 Stahmann et al.
 2015/0196757 A1 7/2015 Stahmann et al.
 2015/0196758 A1 7/2015 Stahmann et al.
 2015/0196769 A1 7/2015 Stahmann et al.
 2015/0217119 A1 8/2015 Nikolski et al.
 2015/0221898 A1 8/2015 Chi et al.
 2015/0224315 A1 8/2015 Stahmann
 2015/0224320 A1 8/2015 Stahmann

2015/0230699 A1 8/2015 Berul et al.
 2015/0238769 A1 8/2015 Demmer et al.
 2015/0258345 A1 9/2015 Smith et al.
 2015/0290468 A1 10/2015 Zhang
 2015/0297905 A1 10/2015 Greenhut et al.
 2015/0297907 A1 10/2015 Zhang
 2015/0305637 A1 10/2015 Greenhut et al.
 2015/0305638 A1 10/2015 Zhang
 2015/0305639 A1 10/2015 Greenhut et al.
 2015/0305640 A1 10/2015 Reinke et al.
 2015/0305641 A1 10/2015 Stadler et al.
 2015/0305642 A1 10/2015 Reinke et al.
 2015/0306374 A1 10/2015 Seifert et al.
 2015/0306375 A1 10/2015 Marshall et al.
 2015/0306401 A1 10/2015 Demmer et al.
 2015/0306406 A1 10/2015 Crutchfield et al.
 2015/0306407 A1 10/2015 Crutchfield et al.
 2015/0306408 A1 10/2015 Greenhut et al.
 2015/0321016 A1 11/2015 O'Brien et al.
 2015/0328459 A1 11/2015 Chin et al.
 2015/0335884 A1 11/2015 Khairkahan et al.
 2016/0015322 A1 1/2016 Anderson et al.
 2016/0023000 A1 1/2016 Cho et al.
 2016/0030757 A1 2/2016 Jacobson
 2016/0033177 A1 2/2016 Barot et al.
 2016/0051823 A1 2/2016 Maile et al.
 2016/0121127 A1 5/2016 Klimovitch et al.
 2016/0121128 A1 5/2016 Fishler et al.
 2016/0121129 A1 5/2016 Persson et al.
 2016/0213919 A1 7/2016 Suwito et al.
 2016/0213937 A1 7/2016 Reinke et al.
 2016/0213939 A1 7/2016 Carney et al.
 2016/0228026 A1 8/2016 Jackson
 2016/0317825 A1 11/2016 Jacobson
 2016/0367823 A1 12/2016 Cowan et al.
 2017/0014629 A1 1/2017 Ghosh et al.
 2017/0035315 A1 2/2017 Jackson
 2017/0043173 A1 2/2017 Sharma et al.
 2017/0043174 A1 2/2017 Greenhut et al.
 2017/0189681 A1 7/2017 Anderson
 2017/0281261 A1 10/2017 Shuros et al.
 2017/0281952 A1 10/2017 Shuros et al.
 2017/0281953 A1 10/2017 Min et al.
 2017/0281955 A1 10/2017 Maile et al.
 2017/0312531 A1 11/2017 Sawchuk
 2018/0256902 A1 9/2018 Toy et al.
 2018/0256909 A1 9/2018 Smith et al.
 2018/0264262 A1 9/2018 Haasl et al.
 2018/0264270 A1 9/2018 Koop et al.
 2018/0264272 A1 9/2018 Haasl et al.
 2018/0264273 A1 9/2018 Haasl et al.
 2018/0264274 A1 9/2018 Haasl et al.
 2018/0339160 A1 11/2018 Carroll

FOREIGN PATENT DOCUMENTS

AU 2014203793 A1 7/2014
 CA 1003904 A1 1/1977
 CN 202933393 U 5/2013
 EP 0362611 A1 4/1990
 EP 503823 A2 9/1992
 EP 0570674 A1 11/1993
 EP 1702648 A2 9/2006
 EP 1904166 B1 6/2011
 EP 2471452 A1 7/2012
 EP 2433675 B1 1/2013
 EP 2441491 B1 1/2013
 EP 2452721 B1 11/2013
 EP 2662113 A3 11/2013
 EP 1948296 B1 1/2014
 EP 2760541 B1 5/2016
 EP 2833966 B1 5/2016
 JP 2000051373 A 2/2000
 JP 2002502640 A 1/2002
 JP 2004512105 A 4/2004
 JP 2005508208 A 3/2005
 JP 2005245215 A 9/2005
 JP 2008540040 A 11/2008
 JP 5199867 B2 2/2013

(56)

References Cited

FOREIGN PATENT DOCUMENTS

WO	9500202	A1	1/1995
WO	9636134	A1	11/1996
WO	9724981	A2	7/1997
WO	9826840	A1	6/1998
WO	9939767	A1	8/1999
WO	0234330	A2	5/2002
WO	02098282	A2	12/2002
WO	2005000206	A3	1/2005
WO	2005042089	A1	5/2005
WO	2006065394	A1	6/2006
WO	2006086435	A3	8/2006
WO	2006113659	A1	10/2006
WO	2006124833	A3	11/2006
WO	2007073435	A1	6/2007
WO	2007075974	A2	7/2007
WO	2009006531	A1	1/2009
WO	2012054102	A1	4/2012
WO	2013080038	A2	6/2013
WO	2013098644	A3	7/2013

WO	2013184787	A1	12/2013
WO	2014120769	A1	8/2014

OTHER PUBLICATIONS

International Search Report and Written Opinion for Application No. PCT/US2017/058102, 26 pages, dated Feb. 6, 2018.

“Instructions for Use System 1, Leadless Cardiac Pacemaker (LCP) and Delivery Catheter,” Nanostim Leadless Pacemakers, pp. 1-28, 2013.

Hachisuka et al., “Development and Performance Analysis of an Intra-Body Communication Device,” The 12th International Conference on Solid State Sensors, Actuators and Microsystems, vol. 4A1.3, pp. 1722-1725, 2003.

Seyedi et al., “A Survey on Intrabody Communications for Body Area Network Application,” IEEE Transactions on Biomedical Engineering, vol. 60(8): 2067-2079, 2013.

Spickler et al., “Totally Self-Contained Intracardiac Pacemaker,” Journal of Electrocardiology, vol. 3(3&4): 324-331, 1970.

Wegmüller, “Intra-Body Communication for Biomedical Sensor Networks,” Diss. ETH, No. 17323, 1-173, 2007.

* cited by examiner

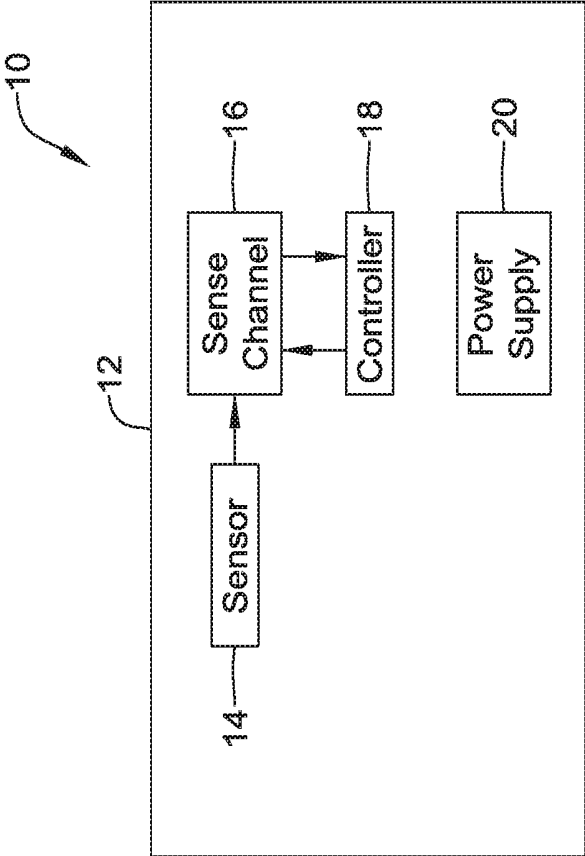

FIG. 1

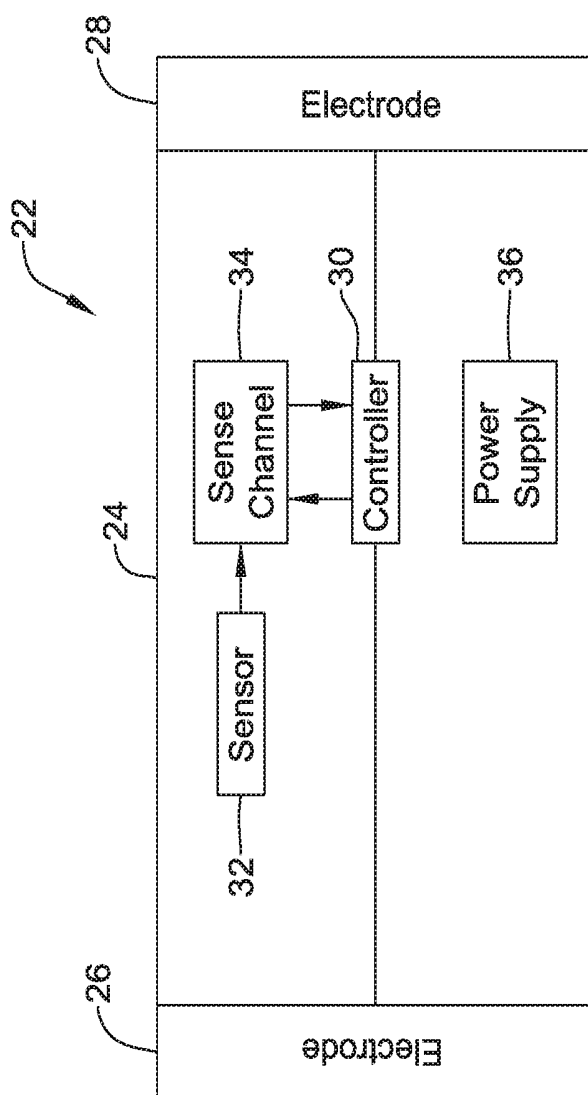

FIG. 2

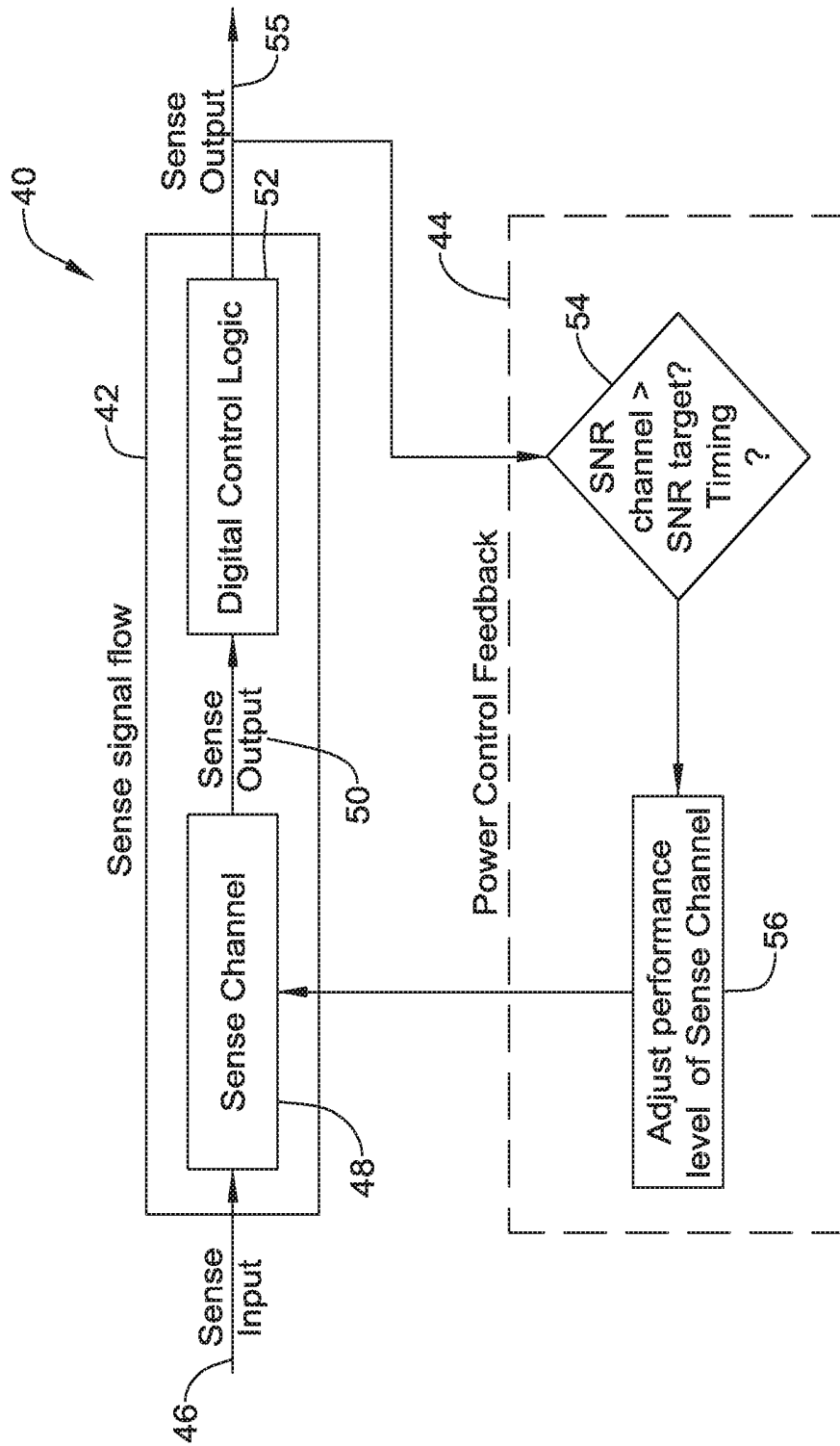

FIG. 3

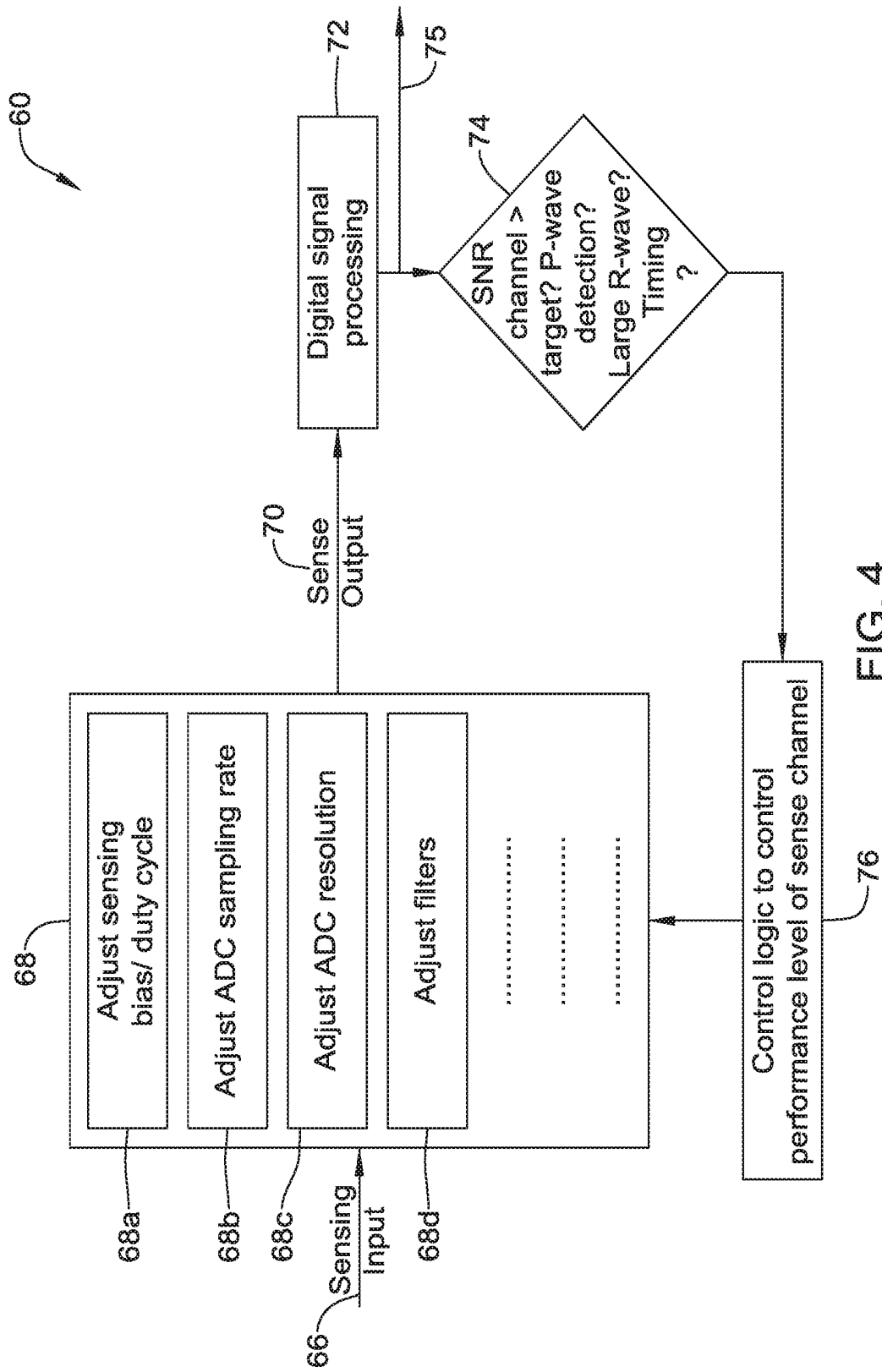

FIG. 4

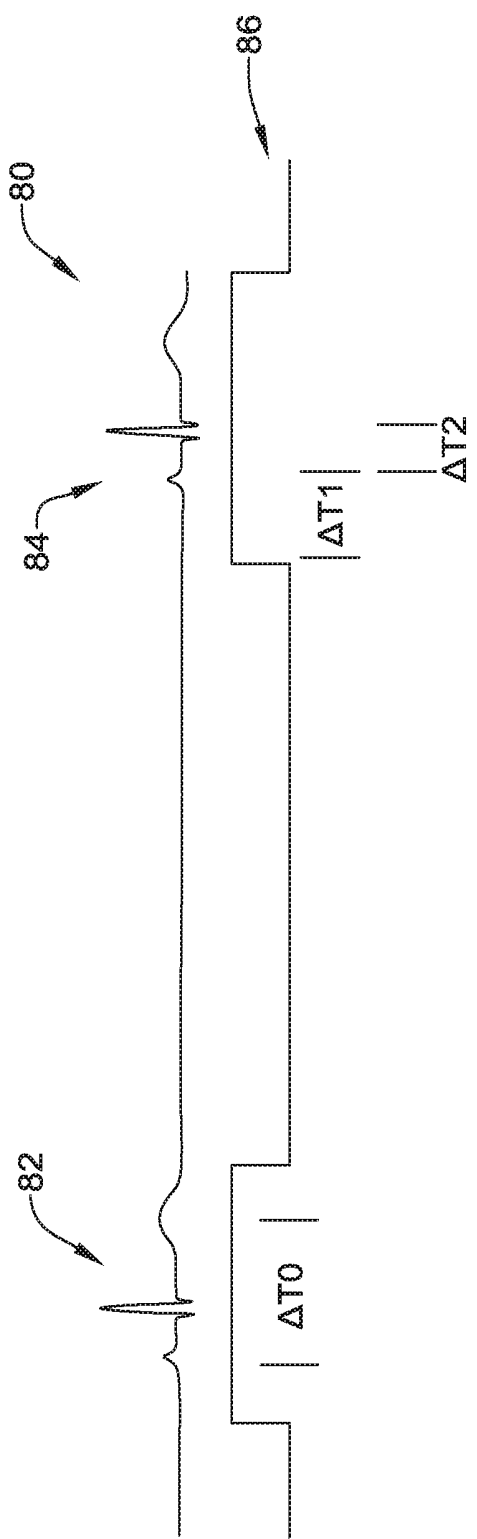

FIG. 5

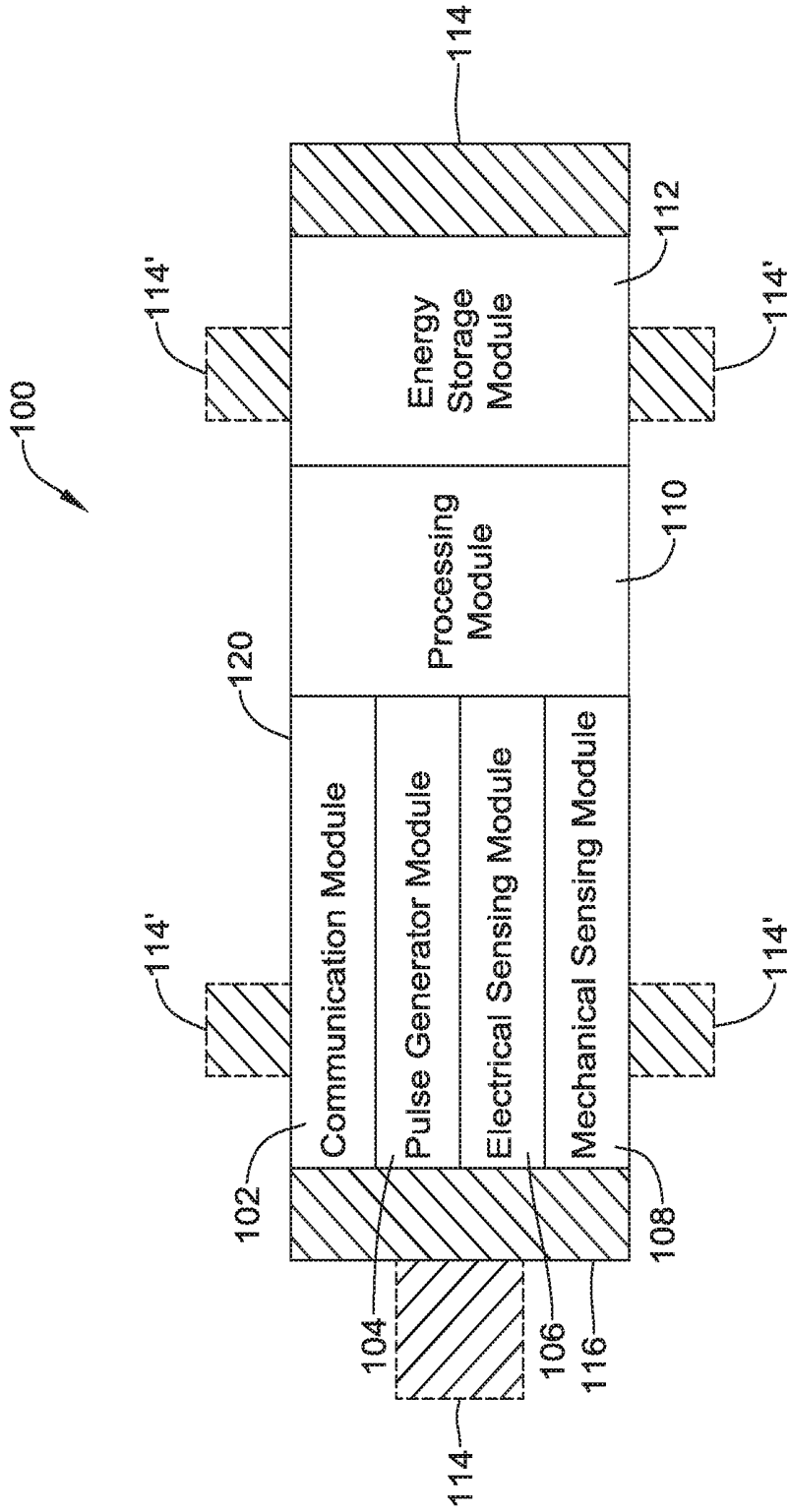

Figure 6

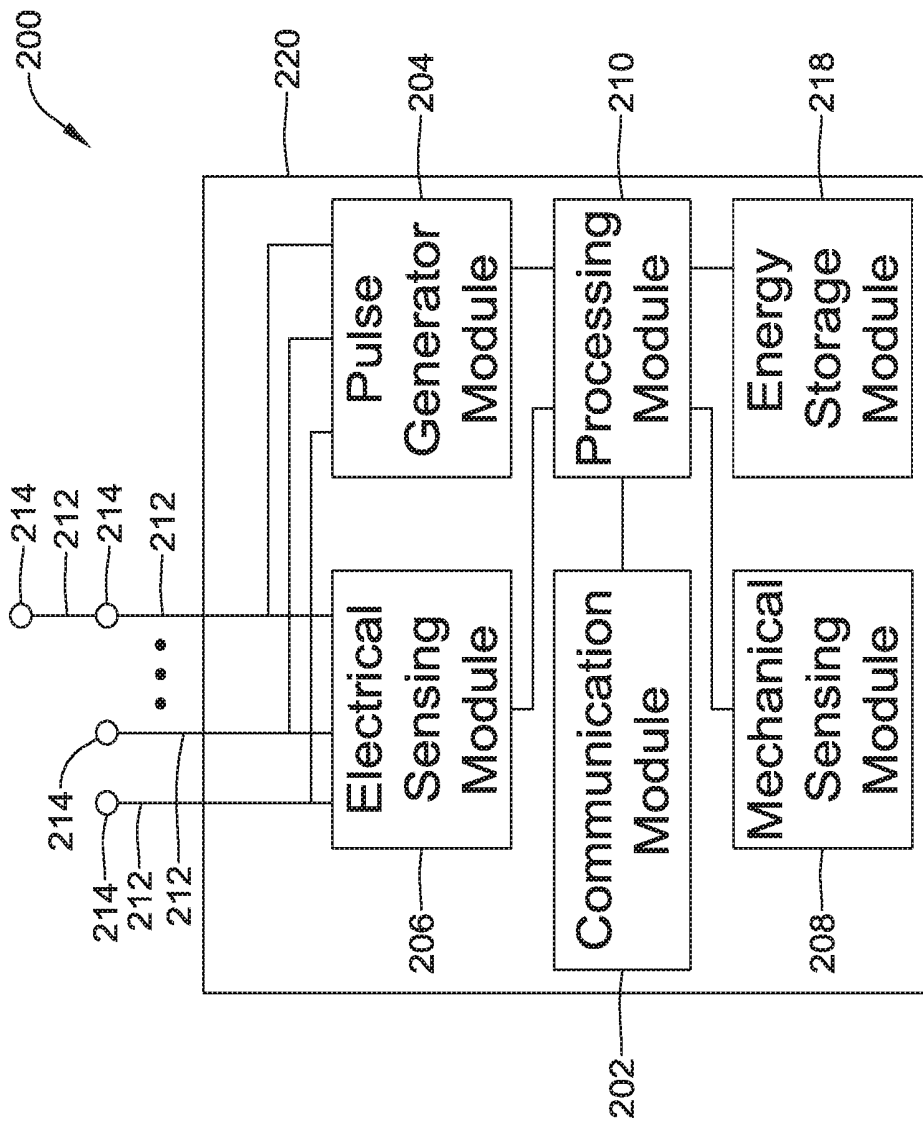

Figure 7

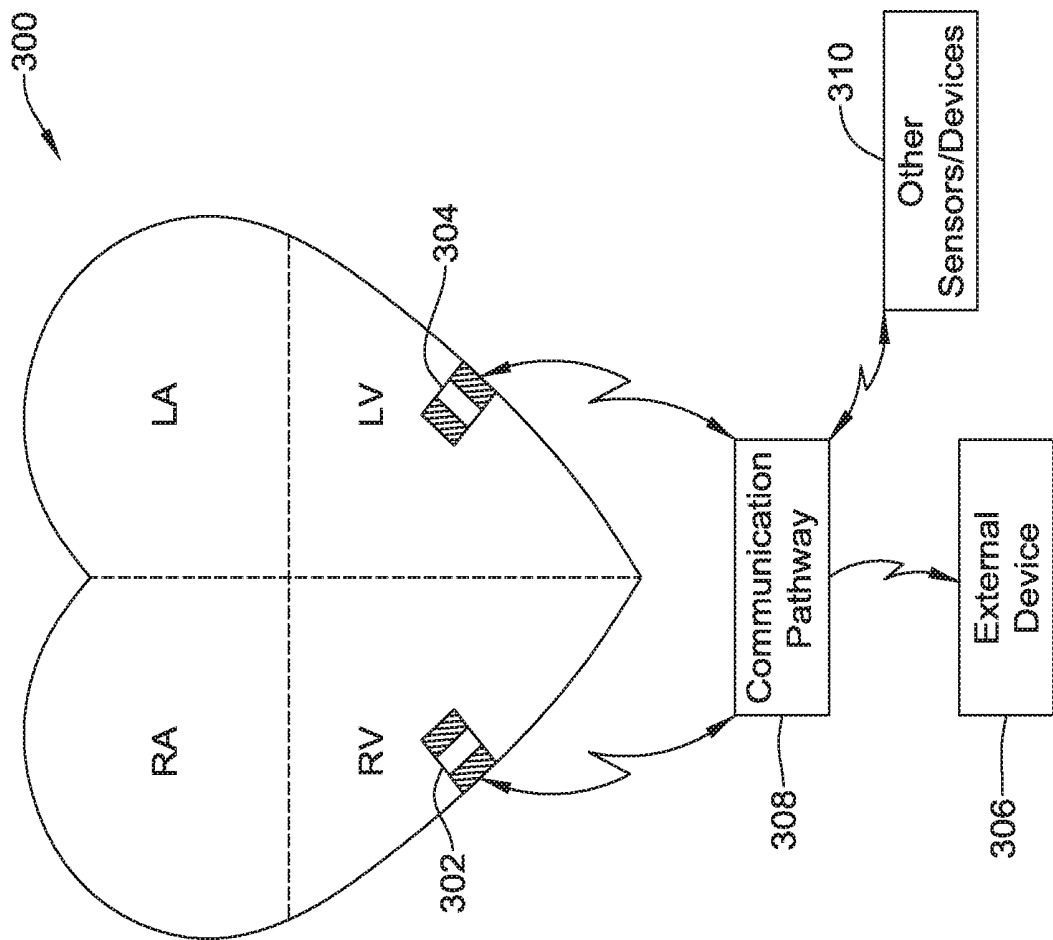

Figure 8

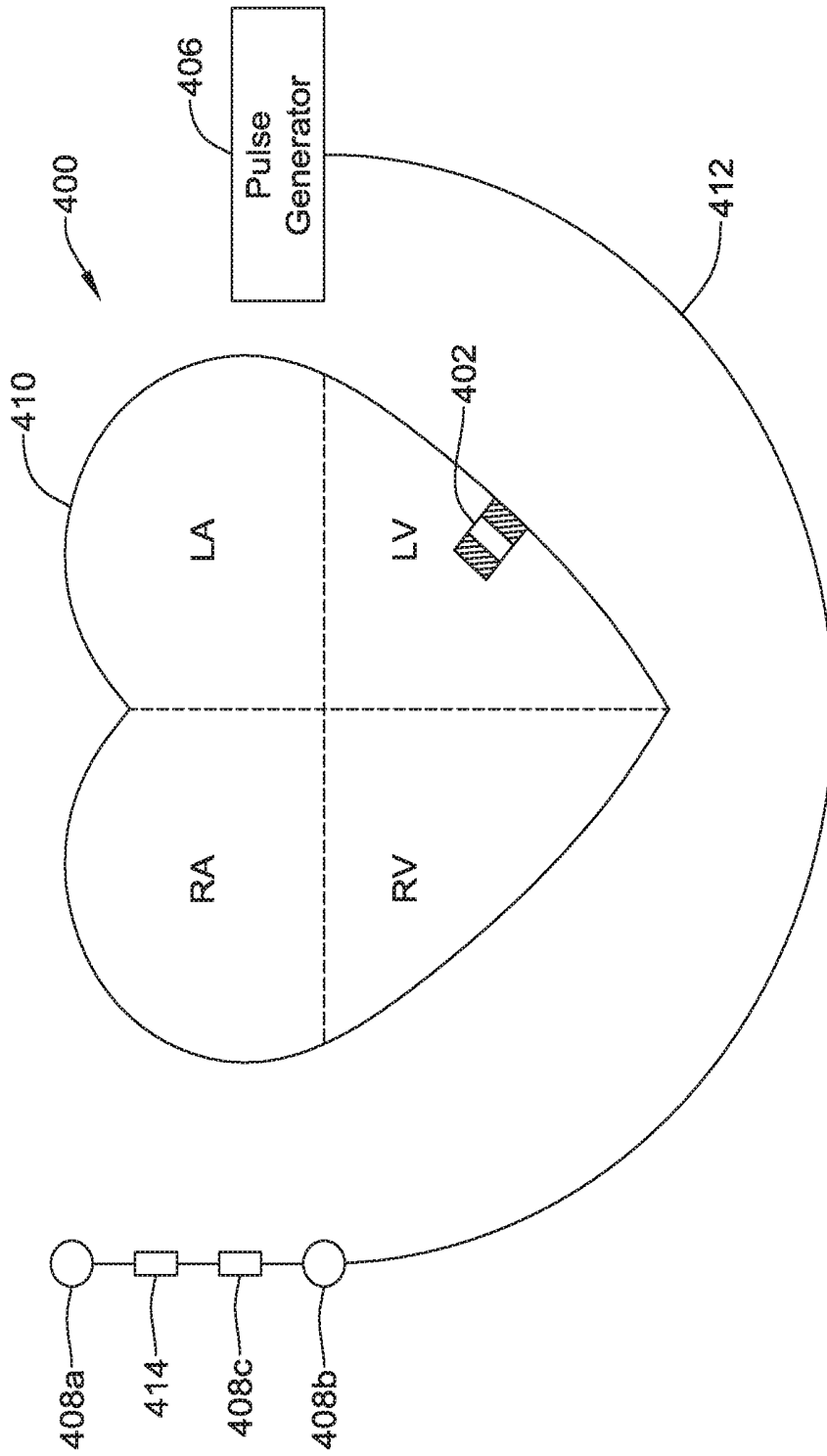

Figure 9

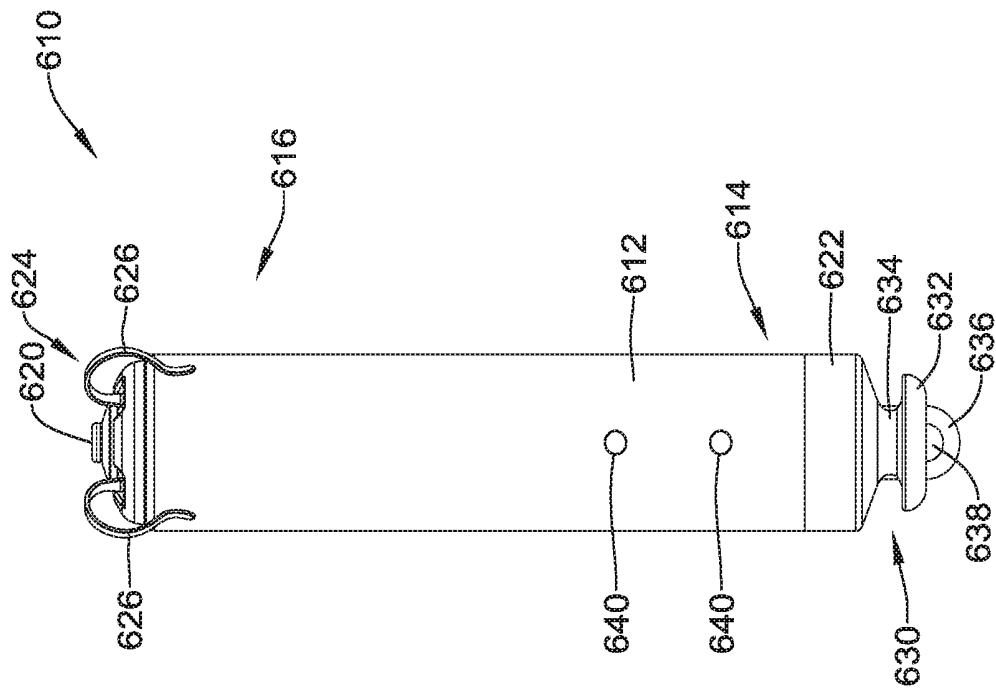

FIG. 10

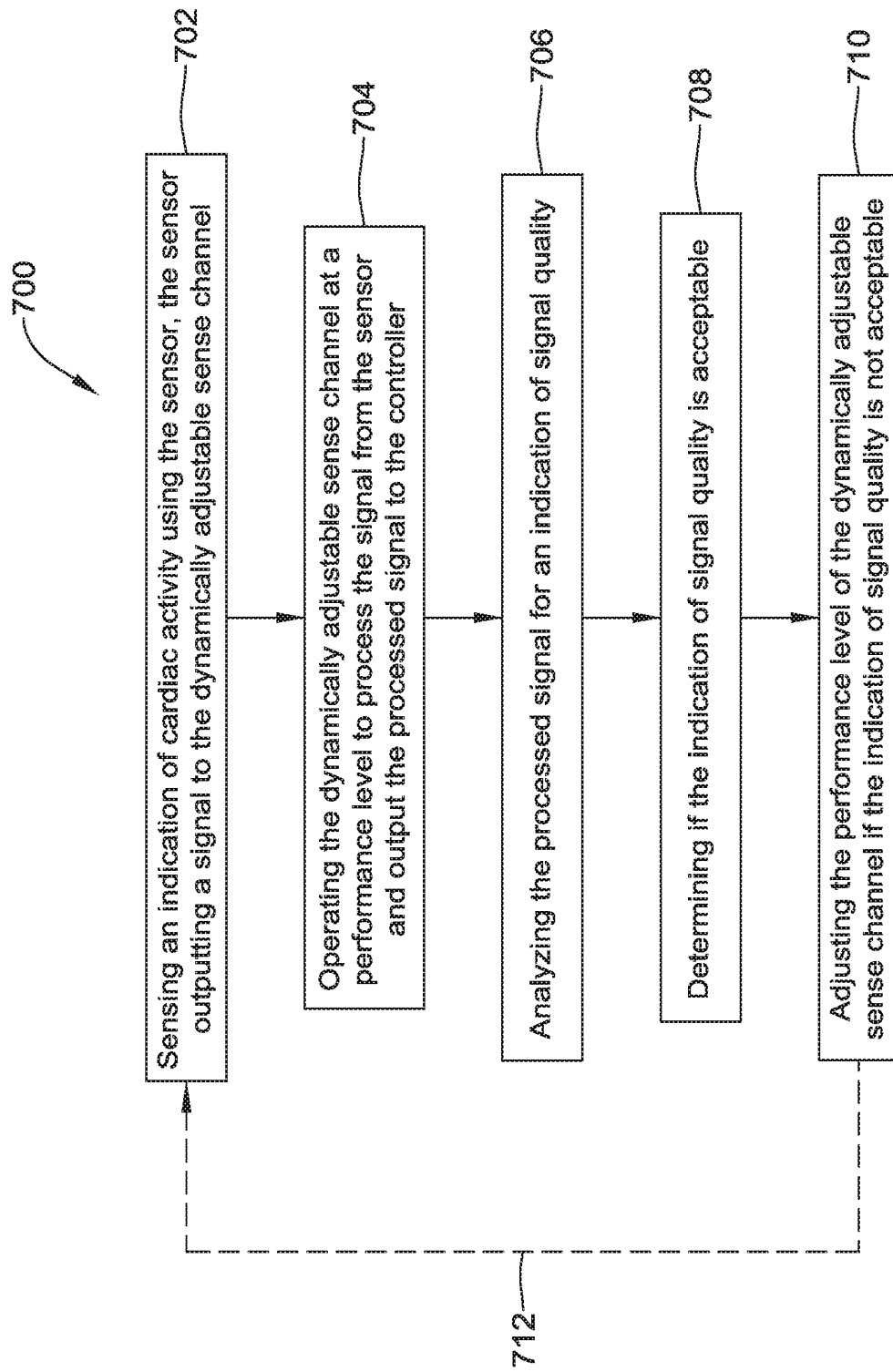

FIG. 11

IMPLANTABLE MEDICAL DEVICE HAVING A SENSE CHANNEL WITH PERFORMANCE ADJUSTMENT

CROSS REFERENCE TO RELATED APPLICATIONS

This application claims the benefit of U.S. Provisional Patent Application Ser. No. 62/413,726 filed on Oct. 27, 2016, the disclosure of which is incorporated herein by reference.

TECHNICAL FIELD

The present disclosure pertains to medical devices, and more particularly to implantable medical devices in which performance may be adjusted

BACKGROUND

Implantable medical devices are commonly used today to monitor and/or delivery therapy to a patient. In one example, many patients suffer from heart conditions that can result in a reduced ability of the heart to deliver sufficient amounts of blood to the patient's body. Such heart conditions may lead to slow, rapid, irregular, and/or inefficient heart contractions. To help alleviate some of these conditions, various medical devices (e.g., pacemakers, defibrillators, etc.) can be implanted in a patient's body. Such devices may monitor and in some cases provide electrical stimulation (e.g. pacing, defibrillation, etc.) to the heart to help the heart operate in a more normal, efficient and/or safe manner. In another example, neuro stimulators are often used to stimulate tissue of a patient to help alleviate pain and/or some other condition. In yet another example, an implantable medical device may simply be a monitor that monitors one or more physiological or other parameters of the patient, and to communicate the sensed parameters to another device such as another implanted medical device or an external programmer. To extend the effective lifetime of such implanted medical devices, there is a desire to conserve energy while still providing effective monitoring and/or delivery of therapy to the patient.

SUMMARY

This disclosure describes implantable medical devices that include a sense channel that can be dynamically adjusted to achieve a desired performance level based on the current conditions and/or current needs. A higher performance level will typically increase the power consumption of the sense channel relative to a lower performance level. By setting the performance level of the sense channel to an appropriate level, the effective lifetime of the power supply of the implantable medical device may be extended.

In one example, an implantable medical device (IMD) may include a housing, a sensor for providing a sensor output signal and a sense channel that is configured to receive the sensor output signal from the sensor, process the sensor output signal, and output a sense channel output signal. The sense channel may have an adjustable performance level, wherein for a higher performance level the sense channel consumes more power and for a lower performance level the sense channel consumes less power. The IMD may include a controller that is configured to receive the sense channel output signal. In some cases, the controller may be configured to adjust the performance level of the

sense channel to achieve more performance and more power consumption when a higher degree of performance is desired and to achieve less performance and less power consumption when a high degree of performance is not desired.

Alternatively or additionally to any of the embodiments above, the controller may be configured to determine a measure of a signal-to-noise ratio (SNR) of the sense channel output signal, and to adjust the performance level of the sense channel based at least in part on the measure of the signal-to-noise ratio (SNR) of the sense channel output signal.

Alternatively or additionally to any of the embodiments above, the performance level of the sense channel may be adjusted by adjusting a noise floor of a sense amplifier of the sense channel.

Alternatively or additionally to any of the embodiments above, the performance level of the sense channel may be adjusted by adjusting a resolution of the sense channel and/or a supply voltage of a sense amplifier of the sense channel.

Alternatively or additionally to any of the embodiments above, the performance level of the sense channel may be adjusted by adjusting a sample rate of the sense channel.

Alternatively or additionally to any of the embodiments above, the sense channel may include a sense amplifier, and the performance level of the sense channel may be adjusted by adjusting a bias of the sense amplifier.

Alternatively or additionally to any of the embodiments above, the sense channel is activated and deactivated at a duty cycle, and the performance level of the sense channel may be adjusted by adjusting the duty cycle of the sense channel.

Alternatively or additionally to any of the embodiments above, the sense channel samples the sensor output signal at a sample rate, and the performance level of the sense channel may be adjusted by adjusting the sample rate of the sense channel.

Alternatively or additionally to any of the embodiments above, the sense channel includes an analog-to-digital (A/D) converter with an adjustable resolution, and the performance level of the sense channel may be adjusted by adjusting the resolution of the A/D converter.

Alternatively or additionally to any of the embodiments above, the IMD is configured to sense and process two or more different cardiac signals, and the controller may be configured to adjust the performance level of the sense channel based at least in part on which of the two or more different cardiac signals is to be sensed and processed. In some cases, the two or more different cardiac signals include an R-wave and a P-Wave, and the controller may be configured to adjust the performance level of the sense channel to achieve more performance and more power consumption when the P-Wave is to be sensed and processed, and to adjust the performance level of the sense channel to achieve less performance and less power consumption when the R-Wave is to be sensed and processed.

Alternatively or additionally to any of the embodiments above, the controller may be configured to automatically and dynamically adjust the performance level of the sense channel.

Alternatively or additionally to any of the embodiments above, the IMD may be a leadless cardiac pacemaker (LCP).

Alternatively or additionally to any of the embodiments above, the IMD may be an insertable cardiac monitor (ICM).

In another example, a leadless cardiac pacemaker (LCP) configured for implantation into a patient's heart may be

configured to sense electrical cardiac activity and to deliver pacing pulses to the patient's heart. The LCP may include a housing, a first electrode that is secured relative to the housing and a second electrode that is secured relative to the housing and is spaced from the first electrode. A controller may be disposed within the housing and may be operably coupled to the first electrode and the second electrode such that the controller is capable of receiving, via the first electrode and the second electrode, electrical cardiac signals of the heart. A sensor may be disposed within the housing and may be configured to sense an indication of cardiac activity and provide a sensor output signal. A sense channel may be configured to receive the sensor output signal from the sensor, process the sensor output signal and to output a sense channel output signal. In some cases, the sense channel may have an adjustable performance level, wherein for a higher performance level the sense channel consumes more power and for a lower performance level the sense channel consumes less power. The controller may be configured to receive the sense channel output signal and to adjust the performance level of the sense channel to achieve more performance and more power consumption when a higher degree of performance is desired and to achieve less performance and less power consumption when a high degree of performance is not desired.

Alternatively or additionally to any of the embodiments above, the LCP may be configured to sense and process two or more different cardiac signals, and the controller may be configured to adjust the performance level of the sense channel based at least in part on which of the two or more different cardiac signals is to be sensed and processed.

Alternatively or additionally to any of the embodiments above, the sensor may include an electrical signal sensor that senses an electric signal between the first electrode and the second electrode.

Alternatively or additionally to any of the embodiments above, the sensor may include one or more of an accelerometer, a pressure sensor, a gyroscope, and a magnetic sensor.

In another example, a method of monitoring a patient's heart using an implantable medical device that is configured for implantation proximate the patient's heart and that includes a sensor configured to sense an indication of cardiac activity, a dynamically adjustable sense channel configured to process a signal from the sensor, and a controller operably coupled to the dynamically adjustable sense channel. The illustrative method includes sensing an indication of cardiac activity using the sensor, the sensor outputting a signal to the dynamically adjustable sense channel. The dynamically adjustable sense channel is operated at a performance level to process the signal from the sensor and output the processed signal to the controller. The processed signal may then be analyzed for an indication of signal quality and a determination may be made as to whether the indication of signal quality is acceptable. The performance level of the dynamically adjustable sense channel may be adjusted upward if the indication of signal quality is not acceptable. In some cases, the performance level of the dynamically adjustable sense channel may be adjusted downward to a lower performance level if the indication of signal quality exceeds a threshold to help reduce power consumption. The illustrative method may further include repeating the sensing, operating, analyzing, determining and adjusting steps until the indication of signal quality is determined to be acceptable.

The above summary of some illustrative embodiments is not intended to describe each disclosed embodiment or

every implementation of the present disclosure. The Figures, and Detailed Description, which follow, more particularly exemplify some of these embodiments.

BRIEF DESCRIPTION OF THE DRAWINGS

The disclosure may be more completely understood in consideration of the following detailed description in connection with the accompanying drawings, in which:

FIG. 1 is a schematic block diagram of an implantable medical device (IMD) in accordance with an example of the disclosure;

FIG. 2 is a schematic block diagram of a leadless cardiac pacemaker (LCP) in accordance with an example of the disclosure;

FIG. 3 is a schematic diagram of an illustrative logic flow that may be used in the IMD of FIG. 1 and/or the LCP of FIG. 2;

FIG. 4 is a schematic diagram of an illustrative logic flow that may be used in the IMD of FIG. 1 and/or the LCP of FIG. 2;

FIG. 5 is a schematic illustration of a cardiac signal, indicating example time ranges for activating a sense channel in order to reduce power consumption;

FIG. 6 is a schematic block diagram of an illustrative LCP in accordance with an example of the disclosure;

FIG. 7 is a schematic block diagram of another illustrative medical device that may be used in conjunction with the LCP of FIG. 6;

FIG. 8 is a schematic diagram of an exemplary medical system that includes multiple LCPs and/or other devices in communication with one another;

FIG. 9 is a schematic diagram of a system including an LCP and another medical device, in accordance with an example of the disclosure;

FIG. 10 is a side view of an illustrative implantable leadless cardiac device; and

FIG. 11 is a flow diagram of an illustrative method for monitoring a patient's heart using the IMD of FIG. 1 and/or the LCP of FIG. 2.

While the disclosure is amenable to various modifications and alternative forms, specifics thereof have been shown by way of example in the drawings and will be described in detail. It should be understood, however, that the intention is not to limit the disclosure to the particular embodiments described. On the contrary, the intention is to cover all modifications, equivalents, and alternatives falling within the spirit and scope of the disclosure.

DETAILED DESCRIPTION

For the following defined terms, these definitions shall be applied, unless a different definition is given in the claims or elsewhere in this specification.

All numeric values are herein assumed to be modified by the term "about," whether or not explicitly indicated. The term "about" generally refers to a range of numbers that one of skill in the art would consider equivalent to the recited value (i.e., having the same function or result). In many instances, the terms "about" may include numbers that are rounded to the nearest significant figure.

The recitation of numerical ranges by endpoints includes all numbers within that range (e.g. 1 to 5 includes 1, 1.5, 2, 2.75, 3, 3.80, 4, and 5).

As used in this specification and the appended claims, the singular forms "a," "an," and "the" include plural referents unless the content clearly dictates otherwise. As used in this

specification and the appended claims, the term “or” is generally employed in its sense including “and/or” unless the content clearly dictates otherwise.

It is noted that references in the specification to “an embodiment”, “some embodiments”, “other embodiments”, etc., indicate that the embodiment described may include one or more particular features, structures, and/or characteristics. However, such recitations do not necessarily mean that all embodiments include the particular features, structures, and/or characteristics. Additionally, when particular features, structures, and/or characteristics are described in connection with one embodiment, it should be understood that such features, structures, and/or characteristics may also be used connection with other embodiments whether or not explicitly described unless clearly stated to the contrary.

The following detailed description should be read with reference to the drawings in which similar structures in different drawings are numbered the same. The drawings, which are not necessarily to scale, depict illustrative embodiments and are not intended to limit the scope of the disclosure.

FIG. 1 is a schematic view of an implantable medical device (IMD) 10. In some cases, the IMD 10 may represent an insertable cardiac monitor (ICM). In some cases, the IMD 10 may represent a cardiac pacemaker such as a leadless cardiac pacemaker (LCP). These are just examples.

Cardiac pacemakers provide electrical stimulation to heart tissue to cause the heart to contract and thus pump blood through the vascular system. Conventional pacemakers may include an electrical lead that extends from a pulse generator implanted subcutaneously or sub-muscularly to an electrode positioned adjacent the inside or outside wall of the cardiac chamber. As an alternative to conventional pacemakers, self-contained or leadless cardiac pacemakers (LCP) have been proposed. Leadless cardiac pacemakers (LCP) are small capsules that may, for example, be fixed to an intracardiac implant site in a cardiac chamber. In some cases, the small capsule may include bipolar pacing/sensing electrodes, a power source (e.g. a battery), and associated electrical circuitry for controlling the pacing/sensing electrodes, and thus may provide electrical stimulation to heart tissue and/or sense a physiological condition. The capsule may be delivered to the heart using a delivery device which may be advanced through a femoral vein, into the inferior vena cava, into the right atrium, through the tricuspid valve, and into the right ventricle. Accordingly, it may be desirable to provide delivery devices which facilitate advancement through the vasculature.

Referring specifically to FIG. 1, and in some instances, the IMD 10 includes a housing 12 and a sensor 14 that may be configured to provide a sensor output signal. In some cases, the sensor 14 may be an electrical signal sensor that senses an electric signal between, for example, two sensor electrodes. In some instances, the sensor 14 may be one or more of an accelerometer, a pressure sensor, a gyroscope and a magnetic sensor. These are just examples. In some cases, a sense channel 16 may be configured to receive the sensor output signal from the sensor 14, process the sensor output signal and output a sense channel output signal. It is contemplated that the sensor output signal may be processed by an analog circuit (e.g. sense amplifier), a digital circuit (e.g. Analog-to-Digital Converter) and/or digital processor, or both. In some cases, the sense channel 16 may have an adjustable performance level, wherein a higher performance level the sense channel 16 consumes more power than a lower performance level.

A controller 18 may be configured to receive the sense channel output signal from the sense channel 16. In some cases, the controller 18 may be configured to adjust the performance level of the sense channel 16 to achieve more performance (and thus more power consumption) when a higher degree of performance is desired, and to achieve less performance (and less power consumption) when a high degree of performance is not desired. In some cases, the controller 18 may be configured to adjust the performance level of the sense channel 16 in accordance with one or more received signals or other indications of the patient’s posture and/or activity level. For example, if the patient is sleeping, the sense channel 16 may be operated at a lower performance level as their cardiac cycle may be expected to vary less, for example. As another example, if the patient is relatively active, the sense channel 16 may be operated at a higher performance level as their cardiac cycle may be expected to vary more.

In some cases, the controller 18 may be configured to dynamically adjust the performance level of the sense channel 16. In some cases, for example, the controller 18 may be configured to determine a measure of a signal-to-noise ratio (SNR) of the sense channel output signal, and adjust the performance level of the sense channel 16 based at least in part on the measure of the signal-to-noise ratio (SNR) of the sense channel output signal. In another example, the IMD 10 may be configured to sense and process two or more different cardiac signals, and the controller 18 may be configured to adjust the performance level of the sense channel 16 based at least in part on which of the two or more different cardiac signals is to be sensed and processed. For example, the two or more different cardiac signals may include an R-wave and a P-Wave, and the controller 18 may be configured to adjust the performance level of the sense channel 16 to achieve more performance and more power consumption when the P-Wave is to be sensed and processed, and to adjust the performance level of the sense channel 16 to achieve less performance and less power consumption when the R-Wave is to be sensed and processed.

In some cases, the performance level of the sense channel 16 may be increased by increasing a noise floor and/or a bias of a sense amplifier (not explicitly shown) of the sense channel 16. In some cases, the performance level of the sense channel may be increased by increasing a sample rate of the sense channel 16. If increased sensitivity is desired, the controller 18 may increase the sample rate of the sense channel 16. In some cases, if increased sensitivity is desired, the controller 18 may increase the supply voltage to the sense channel 16. If power conservation considerations outweigh a need for sensitivity, the controller 18 may decrease the sample rate of the sense channel 16. In some cases, the sense channel 16 may be activated and deactivated at a duty cycle, and the performance level of the sense channel 16 may be adjusted by adjusting the duty cycle of the sense channel 16. In some cases, a duty cycle may correspond to a single cardiac cycle. In some cases, a duty cycle may correspond to several consecutive cardiac cycles. In some instances, for example, the duty cycle may pertain to turning off the sense channel 16 during a refractory period. As another example, in some cases the duty cycle may include turning the sense channel 16 on during a particular cardiac cycle and then turning the sense channel 16 off during a subsequent cardiac cycle. These are just examples. In some cases, the sense channel 16 may include an analog-to-digital (A/D) converter with an adjustable resolution, and the performance level of the sense channel

16 may be adjusted by adjusting the resolution and/or sample rate of the A/D converter.

A power supply 20 may provide power to the sensor 14, sense channel 16 and/or controller 18. The power supply 20 may include a capacitor, a battery and/or any other suitable power storage device. In some cases, the power supply 20 may be a non-rechargeable lithium-based battery. These are just examples. In most cases, the power supply will have a limited power capacity, which limits the effective lifetime of the corresponding implanted medical device. To extend the effective lifetime of the implanted medical device, there is a desire to reduce battery consumption while still providing effective monitoring and/or delivery of therapy to the patient.

FIG. 2 is a schematic view of a leadless cardiac pacemaker (LCP) 22 that is configured for implantation into a patient's heart. The LCP 22 may be configured to sense electrical cardiac activity and to deliver pacing pulses to the patient's heart when appropriate. In some cases, the LCP 22 may include a housing 24, a first electrode 26 that is secured relative to the housing 24, and a second electrode 28 that is secured relative to the housing 24 and that is spaced from the first electrode 26. A controller 30 may be disposed within the housing 24 and may be operably coupled to the first electrode 26 and to the second electrode 28 such that the controller 30 is capable of receiving, via the first electrode 26 and the second electrode 28, electrical cardiac signals of the patient's heart. In some cases, a sensor 32 may be disposed within the housing 24 and may be configured to sense an indication of cardiac activity and/or another parameter relative to the patient and to provide a sensor output signal. A sense channel 34 may be configured to receive the sensor output signal from the sensor 32 and to process (analog and/or digital) the sensor output signal in order to output a sense channel output signal. In some cases, the sense channel 34 may have an adjustable performance level, wherein for a higher performance level the sense channel 34 consumes more power and for a lower performance level the sense channel 34 consumes less power.

The controller 30 may be configured to receive the sense channel output signal and adjust the performance level of the sense channel 34 to achieve more performance and more power consumption when a higher degree of performance is desired and to achieve less performance and less power consumption when a high degree of performance is not desired. The controller 30, sense channel 34 and/or sensor 32 may be operably powered by a power supply 36.

In some cases, the sensor 32 may be an electrical signal sensor that senses an electric signal between the first electrode 26 and the second electrode 28. In some instances, the sensor 32 may be one or more of an accelerometer, a pressure sensor, a gyroscope and a magnetic sensor. These are just some example sensors.

In some cases, the controller 30 may be configured to dynamically adjust the performance level of the sense channel 34. In some cases, for example, the controller 30 may be configured to determine a measure of a signal-to-noise ratio (SNR) of the sense channel output signal, and adjust the performance level of the sense channel 34 based at least in part on the measure of the signal-to-noise ratio (SNR) of the sense channel output signal. In another example, the LCP 22 may be configured to sense and process two or more different cardiac signals, and the controller 30 may be configured to adjust the performance level of the sense channel 34 based at least in part on which of the two or more different cardiac signals is to be sensed and processed. For example, the two or more different cardiac signals may

include an R-wave and a P-Wave, and the controller 30 may be configured to adjust the performance level of the sense channel 34 to achieve more performance and more power consumption when the P-Wave is to be sensed and processed, and to adjust the performance level of the sense channel 34 to achieve less performance and less power consumption when the R-Wave is to be sensed and processed.

In some cases, the performance level of the sense channel 34 may be increased by increasing a noise floor and/or a bias of a sense amplifier (not explicitly shown) of the sense channel 34. In some cases, the performance level of the sense channel 34 may be increased by increasing a sample rate of the sense channel 34. If increased sensitivity is desired, the controller 30 may increase the sample rate of the sense channel 34. If power conservation considerations outweigh a need for sensitivity, the controller 30 may decrease the sample rate of the sense channel 34. In some cases, the sense channel 34 may be activated and deactivated at a duty cycle, and the performance level of the sense channel 34 may be adjusted by adjusting the duty cycle of the sense channel 34. In some cases, the sense channel 34 may include an analog-to-digital (A/D) converter with an adjustable resolution, and the performance level of the sense channel 34 may be adjusted by adjusting the resolution and/or sample rate of the A/D converter. These are just examples.

FIG. 3 is a schematic diagram of an illustrative logic flow 40 that may be used in controlling the sense channel 16 (FIG. 1) and/or the sense channel 34 (FIG. 2). In some cases, the logic flow 40 may be considered as including a sense signal flow block 42 and a power control feedback block 44. In some instances, a sense input 46 may enter the logic flow 40, such as a signal from the sensor 14 (FIG. 1) and/or the sensor 32 (FIG. 2) and pass through the sense channel 48. In the example shown, the sense channel 48 may function to amplify the sense input 46, and provide a sense output signal 50 to a digital control logic block 52. The digital control logic block 52, when provided, may include an Analog-to-Digital Converter (ADC) and/or other digital processing circuitry. In the example shown in FIG. 3, a sense channel output signal 55 exits the digital control logic block 52 and may be used by the controller 18 (FIG. 1) and/or controller 30 (FIG. 2) to control one or more functions of the IMD 10 (FIG. 1) and/or LCP (FIG. 2).

In the example shown in FIG. 3, the sense channel output signal 55 is also provided to the power control feedback block 44. The power control feedback block 44 may be part of the controller 18 (FIG. 1), the controller 30 (FIG. 2), or a separate control block. In FIG. 3, the sense channel output signal 55 is provided to a signal to noise (SNR) decision block 54 of the power control feedback block 44. The SNR decision block 54 may determine a SNR value for the sense channel output signal 55, and may compare the SNR value to a threshold, standard or baseline. In the example shown, the control block 56 may adjust the performance level of the sense channel 48 depending on whether the SNR value is above or below a SNR value. In some cases, the control block 56 may adjust the performance level of the sense channel 48 upward to provide an increased signal to noise ratio (SNR Value) if the desired signal (e.g. P-wave) in the sense input 46 is small relative to existing noise, or perhaps to adjust the performance level of the sense channel 48 downward to reduce the signal to noise ratio (SNR value) if the desired signal (e.g. R-wave) in the sense input 46 is relatively large relative to existing noise. This is just one example.

FIG. 4 is a schematic diagram of an illustrative logic flow 60 that may be used in controlling the sense channel 16 (FIG. 1) and/or the sense channel 34 (FIG. 2). In some instances, a sense input 66 may enter the logic flow 60, such as a signal from the sensor 14 (FIG. 1) and/or the sensor 32 (FIG. 2) and pass through the sense channel 68. In some cases, the sense channel 68 may function to amplify the sense input 66, and provide a sense output signal 70 to a digital signal processing block 72. The digital signal processing block 72, when provided, may include an Analog-to-Digital Converter (ADC) and/or other digital processing circuitry. In the example shown in FIG. 4, a sense channel output signal 75 exits the digital signal processing block 72 and may be used by the controller 18 (FIG. 1) and/or controller 30 (FIG. 2) to control one or more functions of the IMD 10 (FIG. 1) and/or LCP (FIG. 2).

In the example shown in FIG. 4, the sense channel output signal 75 is also provided to a signal to noise (SNR) decision block 74, where a SNR value for a desired signal in the sense channel output signal 75 is estimated or determined. A control block 76 may then adjust the performance level of the sense channel 68 to achieve a desired SNR value in the sense channel output signal 75. In some cases, the SNR value may be directly measured.

Rather than directly measuring the SNR value, it is contemplated that the SNR decision block 74 may simply identify whether the IMD or LCP is currently attempting to sense a smaller signal (e.g. P-wave) that may have a relatively lower signal to noise ratio (SNR), or if the IMD or LCP is currently attempting to sense a larger signal (e.g. an R-wave) that may have a relatively higher signal to noise ratio (SNR). This may be reported to the control block 76. If the IMD or LCP is currently attempting to sense a smaller signal, the control block 76 may automatically increase the performance level of the sense channel 68 at the expense of power consumption, and if the IMD or LCP is currently attempting to sense a larger signal, the control block 76 may decrease the performance level of the sense channel 68 to reduce power consumption. In some cases, the SNR decision block 74 may confirm that the resulting SNR value is sufficient.

Control block 76 may be part of a feedback path to adjust the performance level of the sense channel 68. In some cases, the control block 76 may adjust the sense channel 68 to, for example, provide an increased signal to noise ratio (SNR value) if the sense input 66 is small relative to existing noise, or perhaps to allow a decreased signal to noise ratio (SNR value) if the sense input 66 is relatively robust relative to existing noise. In some cases, the decision block 74 may monitor the sense channel output signal 75 when a desired signal is not expected at the sense input 66 to help identify the existing noise level.

In some cases, the sense channel 68 may have an adjustable performance level. For example, a bias and/or gain of a sense amplifier of the sense channel 68 may be adjusted as shown at block 68a to change the performance level of the sense channel 68. Increasing the gain may amplify a desired signal relative to the existing noise. In another example, a sampling rate and/or resolution (number of bits) of an ADC may be adjusted as shown at blocks 68b and 68c, to change the performance level of the sense channel 68. In another example, one or more filters (Low pass, high pass, band pass) of the sense channel 68 may be activated/deactivated and/or one or more poles of one or more filters may be adjusted, as shown at block 68d, to help filter the noise and thus change the performance level of the sense channel 68. These are just examples.

In some cases, a sense channel or portions thereof may be operated in accordance with an expected timing within, for example, a cardiac cycle. For example, if a sensor operably coupled to a sense channel is configured to sense a P-wave, the sense channel may be configured to turn itself on or to increase its resolution, sensitivity or gain shortly before the next P-wave is expected. To illustrate, FIG. 5 provides a cardiac signal trace 80 including a first QRS complex 82 and a second QRS complex 84 and a timing signal 86. In the example shown, an expected PT time (e.g. an expected time from P-wave to T-wave) may be utilized. This is labeled as delta T0 on the timing signal 86, and may be on the order of 300 milliseconds. In some cases, the sense channel may be activated or placed in a higher performance mode during the period delta T0, and deactivated or placed in a lower performance mode outside of the period delta T0.

In some case, the sense channel may be turned off just before the T-wave (such as about 0 to 50 milliseconds after the previous R-wave), and then may be turned on a time delta T1 before the P-wave. In some cases, P-wave timing may be predicted using a timing fiducial from a previous cardiac cycle, and a time period denoted as delta T2 may be subtracted from an R-R interval (time between a first R-wave and a second R-wave). As another option, a dynamic PT time may be used, based upon the QT interval, which is based on the heart rate. These are just examples of adjusting the performance level of a sense channel based on when a desired signal is expected to be present.

FIG. 6 depicts an illustrative leadless cardiac pacemaker (LCP) that may be implanted into a patient and may operate to deliver appropriate therapy to the heart, such as to deliver anti-tachycardia pacing (ATP) therapy, cardiac resynchronization therapy (CRT), bradycardia therapy, and/or the like. The LCP shown in FIG. 6 may include the features described herein for adjusting the performance level of a sense channel. As can be seen in FIG. 6, the LCP 100 may be a compact device with all components housed within the or directly on a housing 120. In some cases, the LCP 100 may be considered as being an example of the IMD 10 (FIG. 1) and/or the LCP 22 (FIG. 2). In the example shown in FIG. 6, the LCP 100 may include a communication module 102, a pulse generator module 104, an electrical sensing module 106, a mechanical sensing module 108, a processing module 110, a battery 112, and an electrode arrangement 114. The LCP 100 may include more or less modules, depending on the application.

The communication module 102 may be configured to communicate with devices such as sensors, other medical devices such as an SICD, and/or the like, that are located externally to the LCP 100. Such devices may be located either external or internal to the patient's body. Irrespective of the location, external devices (i.e. external to the LCP 100 but not necessarily external to the patient's body) can communicate with the LCP 100 via communication module 102 to accomplish one or more desired functions. For example, the LCP 100 may communicate information, such as sensed electrical signals, data, instructions, messages, R-wave detection markers, etc., to an external medical device (e.g. SICD and/or programmer) through the communication module 102. The external medical device may use the communicated signals, data, instructions, messages, R-wave detection markers, etc., to perform various functions, such as determining occurrences of arrhythmias, delivering electrical stimulation therapy, storing received data, and/or performing any other suitable function. The LCP 100 may additionally receive information such as signals, data, instructions and/or messages from the external

medical device through the communication module **102**, and the LCP **100** may use the received signals, data, instructions and/or messages to perform various functions, such as determining occurrences of arrhythmias, delivering electrical stimulation therapy, storing received data, and/or performing any other suitable function. The communication module **102** may be configured to use one or more methods for communicating with external devices. For example, the communication module **102** may communicate via radio-frequency (RF) signals, inductive coupling, optical signals, acoustic signals, conducted communication signals, and/or any other signals suitable for communication.

In the example shown in FIG. **6**, the pulse generator module **104** may be electrically connected to the electrodes **114**. In some examples, the LCP **100** may additionally include electrodes **114'**. In such examples, the pulse generator **104** may also be electrically connected to the electrodes **114'**. The pulse generator module **104** may be configured to generate electrical stimulation signals. For example, the pulse generator module **104** may generate and deliver electrical stimulation signals by using energy stored in the battery **112** within the LCP **100** and deliver the generated electrical stimulation signals via the electrodes **114** and/or **114'**. Alternatively, or additionally, the pulse generator **104** may include one or more capacitors, and the pulse generator **104** may charge the one or more capacitors by drawing energy from the battery **112**. The pulse generator **104** may then use the energy of the one or more capacitors to deliver the generated electrical stimulation signals via the electrodes **114** and/or **114'**. In at least some examples, the pulse generator **104** of the LCP **100** may include switching circuitry to selectively connect one or more of the electrodes **114** and/or **114'** to the pulse generator **104** in order to select which of the electrodes **114/114'** (and/or other electrodes) the pulse generator **104** delivers the electrical stimulation therapy. The pulse generator module **104** may generate and deliver electrical stimulation signals with particular features or in particular sequences in order to provide one or multiple of a number of different stimulation therapies. For example, the pulse generator module **104** may be configured to generate electrical stimulation signals to provide electrical stimulation therapy to combat bradycardia, tachycardia, cardiac synchronization, bradycardia arrhythmias, tachycardia arrhythmias, fibrillation arrhythmias, cardiac synchronization arrhythmias and/or to produce any other suitable electrical stimulation therapy. Some more common electrical stimulation therapies include anti-tachycardia pacing (ATP) therapy, cardiac resynchronization therapy (CRT), and cardioversion/defibrillation therapy. In some cases, the pulse generator **104** may provide a controllable pulse energy. In some cases, the pulse generator **104** may allow the controller to control the pulse voltage, pulse width, pulse shape or morphology, and/or any other suitable pulse characteristic.

In some examples, the LCP **100** may include an electrical sensing module **106**, and in some cases, a mechanical sensing module **108**. The electrical sensing module **106** may be configured to sense the cardiac electrical activity of the heart. For example, the electrical sensing module **106** may be connected to the electrodes **114/114'**, and the electrical sensing module **106** may be configured to receive cardiac electrical signals conducted through the electrodes **114/114'**. The cardiac electrical signals may represent local information from the chamber in which the LCP **100** is implanted. For instance, if the LCP **100** is implanted within a ventricle of the heart (e.g. RV, LV), cardiac electrical signals sensed by the LCP **100** through the electrodes **114/114'** may repre-

sent ventricular cardiac electrical signals. In some cases, the LCP **100** may be configured to detect cardiac electrical signals from other chambers (e.g. far field), such as the P-wave from the atrium.

The mechanical sensing module **108** may include one or more sensors, such as an accelerometer, a pressure sensor, a heart sound sensor, a blood-oxygen sensor, a chemical sensor, a temperature sensor, a flow sensor and/or any other suitable sensors that are configured to measure one or more mechanical/chemical parameters of the patient. Both the electrical sensing module **106** and the mechanical sensing module **108** may be connected to a processing module **110**, which may provide signals representative of the sensed mechanical parameters. Although described with respect to FIG. **6** as separate sensing modules, in some cases, the electrical sensing module **206** and the mechanical sensing module **208** may be combined into a single sensing module, as desired.

The electrodes **114/114'** can be secured relative to the housing **120** but exposed to the tissue and/or blood surrounding the LCP **100**. In some cases, the electrodes **114** may be generally disposed on either end of the LCP **100** and may be in electrical communication with one or more of the modules **102**, **104**, **106**, **108**, and **110**. The electrodes **114/114'** may be supported by the housing **120**, although in some examples, the electrodes **114/114'** may be connected to the housing **120** through short connecting wires such that the electrodes **114/114'** are not directly secured relative to the housing **120**. In examples where the LCP **100** includes one or more electrodes **114'**, the electrodes **114'** may in some cases be disposed on the sides of the LCP **100**, which may increase the number of electrodes by which the LCP **100** may sense cardiac electrical activity, deliver electrical stimulation and/or communicate with an external medical device. The electrodes **114/114'** can be made up of one or more biocompatible conductive materials such as various metals or alloys that are known to be safe for implantation within a human body. In some instances, the electrodes **114/114'** connected to the LCP **100** may have an insulative portion that electrically isolates the electrodes **114/114'** from adjacent electrodes, the housing **120**, and/or other parts of the LCP **100**. In some cases, one or more of the electrodes **114/114'** may be provided on a tail (not shown) that extends away from the housing **120**.

The processing module **110** can be configured to control the operation of the LCP **100**. For example, the processing module **110** may be configured to receive electrical signals from the electrical sensing module **106** and/or the mechanical sensing module **108**. Based on the received signals, the processing module **110** may determine, for example, abnormalities in the operation of the heart H. Based on any determined abnormalities, the processing module **110** may control the pulse generator module **104** to generate and deliver electrical stimulation in accordance with one or more therapies to treat the determined abnormalities. The processing module **110** may further receive information from the communication module **102**. In some examples, the processing module **110** may use such received information to help determine whether an abnormality is occurring, determine a type of abnormality, and/or to take particular action in response to the information. The processing module **110** may additionally control the communication module **102** to send/receive information to/from other devices.

In some examples, the processing module **110** may include a pre-programmed chip, such as a very-large-scale integration (VLSI) chip and/or an application specific integrated circuit (ASIC). In such embodiments, the chip may be

pre-programmed with control logic in order to control the operation of the LCP 100. By using a pre-programmed chip, the processing module 110 may use less power than other programmable circuits (e.g. general purpose programmable microprocessors) while still being able to maintain basic functionality, thereby potentially increasing the battery life of the LCP 100. In other examples, the processing module 110 may include a programmable microprocessor. Such a programmable microprocessor may allow a user to modify the control logic of the LCP 100 even after implantation, thereby allowing for greater flexibility of the LCP 100 than when using a pre-programmed ASIC. In some examples, the processing module 110 may further include a memory, and the processing module 110 may store information on and read information from the memory. In other examples, the LCP 100 may include a separate memory (not shown) that is in communication with the processing module 110, such that the processing module 110 may read and write information to and from the separate memory.

The battery 112 may provide power to the LCP 100 for its operations. In some examples, the battery 112 may be a non-rechargeable lithium-based battery. In other examples, a non-rechargeable battery may be made from other suitable materials, as desired. Because the LCP 100 is an implantable device, access to the LCP 100 may be limited after implantation. Accordingly, it is desirable to have sufficient battery capacity to deliver therapy over a period of treatment such as days, weeks, months, years or even decades. In some instances, the battery 112 may be a rechargeable battery, which may help increase the useable lifespan of the LCP 100. In still other examples, the battery 112 may be some other type of power source, as desired.

To implant the LCP 100 inside a patient's body, an operator (e.g., a physician, clinician, etc.), may fix the LCP 100 to the cardiac tissue of the patient's heart. To facilitate fixation, the LCP 100 may include one or more anchors 116. The anchor 116 may include any one of a number of fixation or anchoring mechanisms. For example, the anchor 116 may include one or more pins, staples, threads, screws, helix, tines, and/or the like. In some examples, although not shown, the anchor 116 may include threads on its external surface that may run along at least a partial length of the anchor 116. The threads may provide friction between the cardiac tissue and the anchor to help fix the anchor 116 within the cardiac tissue. In other examples, the anchor 116 may include other structures such as barbs, spikes, or the like to facilitate engagement with the surrounding cardiac tissue.

FIG. 7 depicts an example of another or second medical device (MD) 200, which may be used in conjunction with the LCP 100 (FIG. 6) in order to detect and/or treat cardiac abnormalities. In some cases, the MD 200 may be considered as an example of the IMD 10 (FIG. 1) and/or the LCP 22 (FIG. 2). In the example shown, the MD 200 may include a communication module 202, a pulse generator module 204, an electrical sensing module 206, a mechanical sensing module 208, a processing module 210, and a battery 218. Each of these modules may be similar to the modules 102, 104, 106, 108, and 110 of LCP 100. Additionally, the battery 218 may be similar to the battery 112 of the LCP 100. In some examples, however, the MD 200 may have a larger volume within the housing 220. In such examples, the MD 200 may include a larger battery and/or a larger processing module 210 capable of handling more complex operations than the processing module 110 of the LCP 100.

While it is contemplated that the MD 200 may be another leadless device such as shown in FIG. 6, in some instances the MD 200 may include leads such as leads 212. The leads

212 may include electrical wires that conduct electrical signals between the electrodes 214 and one or more modules located within the housing 220. In some cases, the leads 212 may be connected to and extend away from the housing 220 of the MD 200. In some examples, the leads 212 are implanted on, within, or adjacent to a heart of a patient. The leads 212 may contain one or more electrodes 214 positioned at various locations on the leads 212, and in some cases at various distances from the housing 220. Some leads 212 may only include a single electrode 214, while other leads 212 may include multiple electrodes 214. Generally, the electrodes 214 are positioned on the leads 212 such that when the leads 212 are implanted within the patient, one or more of the electrodes 214 are positioned to perform a desired function. In some cases, the one or more of the electrodes 214 may be in contact with the patient's cardiac tissue. In some cases, the one or more of the electrodes 214 may be positioned subcutaneously and outside of the patient's heart. In some cases, the electrodes 214 may conduct intrinsically generated electrical signals to the leads 212, e.g. signals representative of intrinsic cardiac electrical activity. The leads 212 may, in turn, conduct the received electrical signals to one or more of the modules 202, 204, 206, and 208 of the MD 200. In some cases, the MD 200 may generate electrical stimulation signals, and the leads 212 may conduct the generated electrical stimulation signals to the electrodes 214. The electrodes 214 may then conduct the electrical signals and delivery the signals to the patient's heart (either directly or indirectly).

The mechanical sensing module 208, as with the mechanical sensing module 108, may contain or be electrically connected to one or more sensors, such as accelerometers, acoustic sensors, blood pressure sensors, heart sound sensors, blood-oxygen sensors, and/or other sensors which are configured to measure one or more mechanical/chemical parameters of the heart and/or patient. In some examples, one or more of the sensors may be located on the leads 212, but this is not required. In some examples, one or more of the sensors may be located in the housing 220.

While not required, in some examples, the MD 200 may be an implantable medical device. In such examples, the housing 220 of the MD 200 may be implanted in, for example, a transthoracic region of the patient. The housing 220 may generally include any of a number of known materials that are safe for implantation in a human body and may, when implanted, hermetically seal the various components of the MD 200 from fluids and tissues of the patient's body.

In some cases, the MD 200 may be an implantable cardiac pacemaker (ICP). In this example, the MD 200 may have one or more leads, for example the leads 212, which are implanted on or within the patient's heart. The one or more leads 212 may include one or more electrodes 214 that are in contact with cardiac tissue and/or blood of the patient's heart. The MD 200 may be configured to sense intrinsically generated cardiac electrical signals and determine, for example, one or more cardiac arrhythmias based on analysis of the sensed signals. The MD 200 may be configured to deliver CRT, ATP therapy, bradycardia therapy, and/or other therapy types via the leads 212 implanted within the heart. In some examples, the MD 200 may additionally be configured provide defibrillation therapy.

In some instances, the MD 200 may be an implantable cardioverter-defibrillator (ICD). In such examples, the MD 200 may include one or more leads implanted within a patient's heart. The MD 200 may also be configured to sense cardiac electrical signals, determine occurrences of tachyar-

rhythmias based on the sensed signals, and may be configured to deliver defibrillation therapy in response to determining an occurrence of a tachyarrhythmia. In other examples, the MD 200 may be a subcutaneous implantable cardioverter-defibrillator (S-ICD). In examples where the MD 200 is an S-ICD, one of the leads 212 may be a subcutaneously implanted lead. In at least some examples where the MD 200 is an S-ICD, the MD 200 may include only a single lead which is implanted subcutaneously, but this is not required. In some instances, the lead(s) may have one or more electrodes that are placed subcutaneously and outside of the chest cavity. In other examples, the lead(s) may have one or more electrodes that are placed inside of the chest cavity, such as just interior of the sternum but outside of the heart H.

In some examples, the MD 200 may not be an implantable medical device. Rather, the MD 200 may be a device external to the patient's body, and may include skin-electrodes that are placed on a patient's body. In such examples, the MD 200 may be able to sense surface electrical signals (e.g. cardiac electrical signals that are generated by the heart or electrical signals generated by a device implanted within a patient's body and conducted through the body to the skin). In such examples, the MD 200 may be configured to deliver various types of electrical stimulation therapy, including, for example, defibrillation therapy.

FIG. 8 illustrates an example of a medical device system and a communication pathway through which multiple medical devices 302, 304, 306, and/or 310 may communicate. In the example shown, the medical device system 300 may include LCPs 302 and 304, external medical device 306, and other sensors/devices 310. The external device 306 may be any of the devices described previously with respect to the MD 200. Other sensors/devices 310 may also be any of the devices described previously with respect to the MD 200. In some instances, other sensors/devices 310 may include a sensor, such as an accelerometer, an acoustic sensor, a blood pressure sensor, or the like. In some cases, other sensors/devices 310 may include an external programmer device that may be used to program one or more devices of the system 300.

Various devices of the system 300 may communicate via communication pathway 308. For example, the LCPs 302 and/or 304 may sense intrinsic cardiac electrical signals and may communicate such signals to one or more other devices 302/304, 306, and 310 of the system 300 via communication pathway 308. In one example, one or more of the devices 302/304 may receive such signals and, based on the received signals, determine an occurrence of an arrhythmia. In some cases, the device or devices 302/304 may communicate such determinations to one or more other devices 306 and 310 of the system 300. In some cases, one or more of the devices 302/304, 306, and 310 of the system 300 may take action based on the communicated determination of an arrhythmia, such as by delivering a suitable electrical stimulation to the heart of the patient. It is contemplated that the communication pathway 308 may communicate using RF signals, inductive coupling, optical signals, acoustic signals, or any other signals suitable for communication. Additionally, in at least some examples, device communication pathway 308 may include multiple signal types. For instance, other sensors/device 310 may communicate with the external device 306 using a first signal type (e.g. RF communication) but communicate with the LCPs 302/304 using a second signal type (e.g. conducted communication). Further, in some examples, communication between devices may be limited. For instance, as described above, in some examples, the

LCPs 302/304 may communicate with the external device 306 only through other sensors/devices 310, where the LCPs 302/304 send signals to other sensors/devices 310, and other sensors/devices 310 relay the received signals to the external device 306.

In some cases, the communication pathway 308 may include conducted communication. Accordingly, devices of the system 300 may have components that allow for such conducted communication. For instance, the devices of system 300 may be configured to transmit conducted communication signals (e.g. current and/or voltage pulses) into the patient's body via one or more electrodes of a transmitting device, and may receive the conducted communication signals (e.g. pulses) via one or more electrodes of a receiving device. The patient's body may "conduct" the conducted communication signals (e.g. pulses) from the one or more electrodes of the transmitting device to the electrodes of the receiving device in the system 300. In such examples, the delivered conducted communication signals (e.g. pulses) may differ from pacing or other therapy signals. For example, the devices of the system 300 may deliver electrical communication pulses at an amplitude/pulse width that is sub-capture threshold to the heart. Although, in some cases, the amplitude/pulse width of the delivered electrical communication pulses may be above the capture threshold of the heart, but may be delivered during a blanking period of the heart (e.g. refractory period) and/or may be incorporated in or modulated onto a pacing pulse, if desired.

Delivered electrical communication pulses may be modulated in any suitable manner to encode communicated information. In some cases, the communication pulses may be pulse width modulated or amplitude modulated. Alternatively, or in addition, the time between pulses may be modulated to encode desired information. In some cases, conducted communication pulses may be voltage pulses, current pulses, biphasic voltage pulses, biphasic current pulses, or any other suitable electrical pulse as desired.

FIG. 9 shows an illustrative medical device system. In FIG. 9, an LCP 402 is shown fixed to the interior of the left ventricle of the heart 410, and a pulse generator 406 is shown coupled to a lead 412 having one or more electrodes 408a-408c. In some cases, the pulse generator 406 may be part of a subcutaneous implantable cardioverter-defibrillator (S-ICD), and the one or more electrodes 408a-408c may be positioned subcutaneously. In some cases, the one or more electrodes 408a-408c may be placed inside of the chest cavity but outside of the heart, such as just interior of the sternum.

In some cases, the LCP 402 may communicate with the subcutaneous implantable cardioverter-defibrillator (S-ICD). In some cases, the lead 412 and/or pulse generator 406 may include an accelerometer 414 that may, for example, be configured to sense vibrations that may be indicative of heart sounds.

In some cases, the LCP 402 may be in the right ventricle, right atrium, left ventricle or left atrium of the heart, as desired. In some cases, more than one LCP 402 may be implanted. For example, one LCP may be implanted in the right ventricle and another may be implanted in the right atrium. In another example, one LCP may be implanted in the right ventricle and another may be implanted in the left ventricle. In yet another example, one LCP may be implanted in each of the chambers of the heart.

FIG. 10 is a side view of an illustrative implantable leadless cardiac pacemaker (LCP) 610. The LCP 610 may be similar in form and function to the LCP 100 described above. The LCP 610 may include any of the modules and/or

structural features described above with respect to the LCP 100 described above. The LCP 610 may include a shell or housing 612 having a proximal end 614 and a distal end 616. The illustrative LCP 610 includes a first electrode 620 secured relative to the housing 612 and positioned adjacent to the distal end 616 of the housing 612 and a second electrode 622 secured relative to the housing 612 and positioned adjacent to the proximal end 614 of the housing 612. In some cases, the housing 612 may include a conductive material and may be insulated along a portion of its length. A section along the proximal end 614 may be free of insulation so as to define the second electrode 622. The electrodes 620, 622 may be sensing and/or pacing electrodes to provide electro-therapy and/or sensing capabilities. The first electrode 620 may be capable of being positioned against or may otherwise contact the cardiac tissue of the heart while the second electrode 622 may be spaced away from the first electrode 620. The first and/or second electrodes 620, 622 may be exposed to the environment outside the housing 612 (e.g. to blood and/or tissue).

In some cases, the LCP 610 may include a pulse generator (e.g., electrical circuitry) and a power source (e.g., a battery) within the housing 612 to provide electrical signals to the electrodes 620, 622 to control the pacing/sensing electrodes 620, 622. While not explicitly shown, the LCP 610 may also include, a communications module, an electrical sensing module, a mechanical sensing module, and/or a processing module, and the associated circuitry, similar in form and function to the modules 102, 106, 108, 110 described above. The various modules and electrical circuitry may be disposed within the housing 612. Electrical connections between the pulse generator and the electrodes 620, 622 may allow electrical stimulation to heart tissue and/or sense a physiological condition.

In the example shown, the LCP 610 includes a fixation mechanism 624 proximate the distal end 616 of the housing 612. The fixation mechanism 624 is configured to attach the LCP 610 to a wall of the heart H, or otherwise anchor the LCP 610 to the anatomy of the patient. In some instances, the fixation mechanism 624 may include one or more, or a plurality of hooks or tines 626 anchored into the cardiac tissue of the heart H to attach the LCP 610 to a tissue wall. In other instances, the fixation mechanism 624 may include one or more, or a plurality of passive tines, configured to entangle with trabeculae within the chamber of the heart H and/or a helical fixation anchor configured to be screwed into a tissue wall to anchor the LCP 610 to the heart H. These are just examples.

The LCP 610 may further include a docking member 630 proximate the proximal end 614 of the housing 612. The docking member 630 may be configured to facilitate delivery and/or retrieval of the LCP 610. For example, the docking member 630 may extend from the proximal end 614 of the housing 612 along a longitudinal axis of the housing 612. The docking member 630 may include a head portion 632 and a neck portion 634 extending between the housing 612 and the head portion 632. The head portion 632 may be an enlarged portion relative to the neck portion 634. For example, the head portion 632 may have a radial dimension from the longitudinal axis of the LCP 610 that is greater than a radial dimension of the neck portion 634 from the longitudinal axis of the LCP 610. In some cases, the docking member 630 may further include a tether retention structure 636 extending from or recessed within the head portion 632. The tether retention structure 636 may define an opening 638 configured to receive a tether or other anchoring mechanism therethrough. While the retention structure 636 is

shown as having a generally “U-shaped” configuration, the retention structure 636 may take any shape that provides an enclosed perimeter surrounding the opening 638 such that a tether may be securably and releasably passed (e.g. looped) through the opening 638. In some cases, the retention structure 636 may extend though the head portion 632, along the neck portion 634, and to or into the proximal end 614 of the housing 612. The docking member 630 may be configured to facilitate delivery of the LCP 610 to the intracardiac site and/or retrieval of the LCP 610 from the intracardiac site. While this describes one example docking member 630, it is contemplated that the docking member 630, when provided, can have any suitable configuration.

It is contemplated that the LCP 610 may include one or more pressure sensors 640 coupled to or formed within the housing 612 such that the pressure sensor(s) is exposed to the environment outside the housing 612 to measure blood pressure within the heart. For example, if the LCP 610 is placed in the left ventricle, the pressure sensor(s) 640 may measure the pressure within the left ventricle. If the LCP 610 is placed in another portion of the heart (such as one of the atriums or the right ventricle), the pressures sensor(s) may measure the pressure within that portion of the heart. The pressure sensor(s) 640 may include a MEMS device, such as a MEMS device with a pressure diaphragm and piezoresistors on the diaphragm, a piezoelectric sensor, a capacitor-Micro-machined Ultrasonic Transducer (cMUT), a condenser, a micro-monometer, or any other suitable sensor adapted for measuring cardiac pressure. The pressures sensor(s) 640 may be part of a mechanical sensing module described herein. It is contemplated that the pressure measurements obtained from the pressures sensor(s) 640 may be used to generate a pressure curve over cardiac cycles. The pressure readings may be taken in combination with impedance measurements (e.g. the impedance between electrodes 620 and 622) to generate a pressure-impedance loop for one or more cardiac cycles as will be described in more detail below. The impedance may be a surrogate for chamber volume, and thus the pressure-impedance loop may be representative for a pressure-volume loop for the heart H.

In some embodiments, the LCP 610 may be configured to measure impedance between the electrodes 620, 622. More generally, the impedance may be measured between other electrode pairs, such as the additional electrodes 114' described above. In some cases, the impedance may be measure between two spaced LCP's, such as two LCP's implanted within the same chamber (e.g. LV) of the heart H, or two LCP's implanted in different chambers of the heart H (e.g. RV and LV). The processing module of the LCP 610 and/or external support devices may derive a measure of cardiac volume from intracardiac impedance measurements made between the electrodes 620, 622 (or other electrodes). Primarily due to the difference in the resistivity of blood and the resistivity of the cardiac tissue of the heart H, the impedance measurement may vary during a cardiac cycle as the volume of blood (and thus the volume of the chamber) surrounding the LCP changes. In some cases, the measure of cardiac volume may be a relative measure, rather than an actual measure. In some cases, the intracardiac impedance may be correlated to an actual measure of cardiac volume via a calibration process, sometimes performed during implantation of the LCP(s). During the calibration process, the actual cardiac volume may be determined using fluoroscopy or the like, and the measured impedance may be correlated to the actual cardiac volume.

In some cases, the LCP 610 may be provided with energy delivery circuitry operatively coupled to the first electrode

620 and the second electrode 622 for causing a current to flow between the first electrode 620 and the second electrode 622 in order to determine the impedance between the two electrodes 620, 622 (or other electrode pair). It is contemplated that the energy delivery circuitry may also be configured to deliver pacing pulses via the first and/or second electrodes 620, 622. The LCP 610 may further include detection circuitry operatively coupled to the first electrode 620 and the second electrode 622 for detecting an electrical signal received between the first electrode 620 and the second electrode 622. In some instances, the detection circuitry may be configured to detect cardiac signals received between the first electrode 620 and the second electrode 622.

When the energy delivery circuitry delivers a current between the first electrode 620 and the second electrode 622, the detection circuitry may measure a resulting voltage between the first electrode 620 and the second electrode 622 (or between a third and fourth electrode separate from the first electrode 620 and the second electrode 622, not shown) to determine the impedance. When the energy delivery circuitry delivers a voltage between the first electrode 620 and the second electrode 622, the detection circuitry may measure a resulting current between the first electrode 620 and the second electrode 622 (or between a third and fourth electrode separate from the first electrode 620 and the second electrode 622) to determine the impedance.

FIG. 11 is a flow diagram showing an illustrative method 700 of monitoring a patient's heart using an implantable medical device (such as, but not limited to, the IMD 10 of FIG. 1, the LCP of FIG. 2, the LCP of FIG. 6, the LCP of FIG. 10) that is configured for implantation proximate the patient's heart and that includes a sensor configured to sense an indication of cardiac activity and a dynamically adjustable sense channel configured to process a signal from the sensor. The implantable medical device may further include a controller to dynamically adjust the performance level of the sense channel. As generally seen at block 702, an indication of cardiac activity may be sensed using the sensor. The sensor outputs a signal to the dynamically adjustable sense channel. The dynamically adjustable sense channel may be operated at a performance level to process the signal from the sensor and output the processed signal to the controller, as indicated at block 704. In some cases, and as seen at block 706, the processed signal may be analyzed for an indication of signal quality and a determination may be made as to whether the indication of signal quality is acceptable, as indicated at block 708. In some cases, and as seen at block 710, the performance level of the dynamically adjustable sense channel may be adjusted upward if the indication of signal quality is not acceptable. In some cases, the performance level of the dynamically adjustable sense channel may be adjusted downward to a lower performance level if the indication of signal quality exceeds a threshold in order to help reduce power consumption of the implantable medical device. In some cases, these steps may be repeated until the indication of signal quality is determined to be acceptable, as indicated by a dashed control line 712.

It should be understood that this disclosure is, in many respects, only illustrative. Changes may be made in details, particularly in matters of shape, size, and arrangement of steps without exceeding the scope of the disclosure. This may include, to the extent that it is appropriate, the use of any of the features of one example embodiment being used in other embodiments. The disclosure's scope is, of course, defined in the language in which the appended claims are expressed.

What is claimed is:

1. An implantable medical device (IMD) comprising:
 - a housing;
 - a sensor for providing a sensor output signal;
 - a sense channel receiving the sensor output signal from the sensor, the sense channel processing the sensor output signal and outputting a sense channel output signal;
 - the sense channel having an adjustable performance level, wherein for a higher performance level the sense channel consumes more power and for a lower performance level the sense channel consumes less power;
 - a controller receiving the sense channel output signal; and
 - the controller adjusting the performance level of the sense channel to achieve more performance and more power consumption when a higher degree of performance is desired and to achieve less performance and less power consumption when a high degree of performance is not desired.
2. The IMD of claim 1, wherein the controller determines a measure of a signal-to-noise ratio (SNR) of the sense channel output signal, and adjusts the performance level of the sense channel based at least in part on the measure of the signal-to-noise ratio (SNR) of the sense channel output signal.
3. The IMD of claim 1, wherein the performance level of the sense channel is adjusted by adjusting a noise floor of a sense amplifier of the sense channel.
4. The IMD of claim 1, wherein the performance level of the sense channel is adjusted by adjusting a resolution of the sense channel and/or a supply voltage of a sense amplifier of the sense channel.
5. The IMD of claim 1, wherein the performance level of the sense channel is adjusted by adjusted a sample rate of the sense channel.
6. The IMD of claim 1, wherein the sense channel comprises a sense amplifier, and wherein the performance level of the sense channel is adjusted by adjusting a bias of the sense amplifier.
7. The IMD of claim 1, wherein the sense channel is activated and deactivated at a duty cycle, and wherein the performance level of the sense channel is adjusted by adjusting the duty cycle of the sense channel.
8. The IMD of claim 1, wherein the sense channel samples the sensor output signal at a sample rate, and wherein the performance level of the sense channel is adjusted by adjusting the sample rate of the sense channel.
9. The IMD of claim 1, wherein the sense channel comprises an analog-to-digital (A/D) converter with an adjustable resolution, and wherein the performance level of the sense channel is adjusted by adjusting the resolution of the A/D converter.
10. The IMD of claim 1, wherein the IMD senses and processes two or more different cardiac signals, and wherein the controller adjusts the performance level of the sense channel based at least in part on which of the two or more different cardiac signals is to be sensed and processed.
11. The IMD of claim 10, wherein the two or more different cardiac signals comprise an R-wave and a P-Wave, and wherein the controller adjusts the performance level of the sense channel to achieve more performance and more power consumption when the P-Wave is to be sensed and processed, and adjusts the performance level of the sense channel to achieve less performance and less power consumption when the R-Wave is to be sensed and processed.
12. The IMD of claim 1, wherein the controller dynamically adjusts the performance level of the sense channel.

21

13. The IMD of claim 1, comprising a leadless cardiac pacemaker (LCP).

14. The IMD of claim 1, comprising an insertable cardiac monitor (ICM).

15. A leadless cardiac pacemaker (LCP) configured for implantation into a patient's heart, the LCP configured to sense electrical cardiac activity and to deliver pacing pulses to the patient's heart, the LCP comprising:

- a housing;
- a first electrode secured relative to the housing;
- a second electrode secured relative to the housing, the second electrode spaced from the first electrode;
- a controller disposed within the housing and operably coupled to the first electrode and the second electrode such that the controller is capable of receiving, via the first electrode and the second electrode, electrical cardiac signals of the heart;
- a sensor disposed within the housing, the sensor sensing an indication of cardiac activity and providing a sensor output signal;
- a sense channel receiving the sensor output signal from the sensor, the sense channel processing the sensor output signal and outputting a sense channel output signal;
- the sense channel having an adjustable performance level, wherein for a higher performance level the sense channel consumes more power and for a lower performance level the sense channel consumes less power;
- the controller receiving the sense channel output signal; and
- the controller adjusting the performance level of the sense channel to achieve more performance and more power consumption when a higher degree of performance is desired and to achieve less performance and less power consumption when a high degree of performance is not desired.

16. The LCP of claim 15, wherein the LCP senses and processes two or more different cardiac signals, and wherein

22

the controller adjusts the performance level of the sense channel based at least in part on which of the two or more different cardiac signals is to be sensed and processed.

17. The LCP of claim 15, wherein the sensor comprises an electrical signal sensor that senses an electric signal between the first electrode and the second electrode.

18. The LCP of claim 15, wherein the sensor comprises one or more of an accelerometer, a pressure sensor, a gyroscope, and a magnetic sensor.

19. A method of monitoring a patient's heart using an implantable medical device configured for implantation proximate the patient's heart, the implantable medical device including a sensor configured to sense an indication of cardiac activity and a dynamically adjustable sense channel configured to process a signal from the sensor, the implantable medical device further including a controller operably coupled to the dynamically adjustable sense channel, the method comprising:

- sensing an indication of cardiac activity using the sensor, the sensor outputting a signal to the dynamically adjustable sense channel;
- operating the dynamically adjustable sense channel at a performance level to process the signal from the sensor and output the processed signal to the controller;
- analyzing the processed signal for an indication of signal quality;
- determining if the indication of signal quality is acceptable; and
- adjusting the performance level of the dynamically adjustable sense channel if the indication of signal quality is not acceptable.

20. The method of claim 19, further comprising: repeating the sensing, operating, analyzing, determining and adjusting steps until the indication of signal quality is determined to be acceptable.

* * * * *

专利名称(译)	具有可调节性能的感测通道的可植入医疗设备		
公开(公告)号	US10561330	公开(公告)日	2020-02-18
申请号	US15/792353	申请日	2017-10-24
[标]申请(专利权)人(译)	心脏起搏器股份公司		
申请(专利权)人(译)	心脏起搏器, INC.		
当前申请(专利权)人(译)	心脏起搏器, INC.		
[标]发明人	KHARAM ALEKSANDRA BALCZEWSKI RON A HUELSKAMP PAUL MAILE KEITH R		
发明人	KHARAM, ALEKSANDRA BALCZEWSKI, RON A. HUELSKAMP, PAUL JUFFER, LANCE ERIC MAILE, KEITH R.		
IPC分类号	A61B5/0402 A61N1/37 A61N1/378 A61N1/375 A61B5/00 A61B5/0456 A61N1/372		
CPC分类号	A61N1/3708 A61N1/3756 A61N1/37512 A61N1/37205 A61B5/7221 A61N1/3704 A61N1/37252 A61N1/378 A61B5/0402 A61B5/7203 A61B5/0456 A61B5/686 A61B2560/0209		
优先权	62/413726 2016-10-27 US		
其他公开文献	US20180116540A1		
外部链接	Espacenet		

摘要(译)

植入式医疗设备 (IMD) 可以包括用于提供传感器输出信号的传感器和被配置为从传感器接收传感器输出信号的感测通道。感测通道可以被配置为处理传感器输出信号并输出感测通道输出信号。感测通道可以具有可调节的性能水平, 其中, 对于较高的性能水平, 感测通道比较低的性能水平消耗更多的功率。控制器可以被配置为在需要更高度度的感测通道性能时调整感测通道的性能水平以实现更高的性能和更多的功耗, 并且在期望更高度度的性能时实现更低的性能和更低的功耗。

