



US009283409B2

(12) **United States Patent**
Slayton et al.

(10) **Patent No.:** **US 9,283,409 B2**
(45) **Date of Patent:** ***Mar. 15, 2016**

(54) **ENERGY BASED FAT REDUCTION**

(71) Applicant: **Guided Therapy Systems, LLC**, Mesa, AZ (US)

(72) Inventors: **Michael H. Slayton**, Tempe, AZ (US);
Peter G. Barthe, Phoenix, AZ (US)

(73) Assignee: **Guided Therapy Systems, LLC**, Mesa, AZ (US)

(*) Notice: Subject to any disclaimer, the term of this patent is extended or adjusted under 35 U.S.C. 154(b) by 0 days.

This patent is subject to a terminal disclaimer.

(21) Appl. No.: **14/550,772**

(22) Filed: **Nov. 21, 2014**

(65) **Prior Publication Data**

US 2015/0088182 A1 Mar. 26, 2015

Related U.S. Application Data

(63) Continuation of application No. 14/192,520, filed on Feb. 27, 2014, now Pat. No. 8,920,324, which is a continuation of application No. 12/646,609, filed on Dec. 23, 2009, now Pat. No. 8,663,112, which is a

(Continued)

(51) **Int. Cl.**

A61B 8/00 (2006.01)

A61N 7/00 (2006.01)

(Continued)

(52) **U.S. Cl.**

CPC **A61N 7/00** (2013.01); **A61B 5/4869** (2013.01); **A61B 8/429** (2013.01); **A61B 8/4483** (2013.01); **A61B 8/483** (2013.01); **A61N 7/02** (2013.01); **B06B 1/0622** (2013.01); **G01S 7/5208** (2013.01); **G01S 15/8906** (2013.01);

(Continued)

(58) **Field of Classification Search**

CPC **A61N 7/02**; **A61N 2007/0008**
See application file for complete search history.

(56) **References Cited**

U.S. PATENT DOCUMENTS

2,427,348 A 9/1947 Bond et al.
3,913,386 A 10/1975 Saglio

(Continued)

FOREIGN PATENT DOCUMENTS

CN 104027893 9/2014
DE 4029175 3/1992

(Continued)

OTHER PUBLICATIONS

Calderhead et al., "One Mechanism Behind LED Photo-Therapy for Wound Healing and Skin Rejuvenation: Key Role of the Mast Cell" *Laser Therapy* 17.3: 141-148 (2008).

(Continued)

Primary Examiner — Bo J Peng

(74) *Attorney, Agent, or Firm* — Knobbe, Martens, Olson & Bear, LLP

(57) **ABSTRACT**

Methods for non-invasive fat reduction can include targeting a region of interest below a surface of skin, which contains fat and delivering ultrasound energy to the region of interest. The ultrasound energy generates a thermal lesion with said ultrasound energy on a fat cell. The lesion can create an opening in the surface of the fat cell, which allows the draining of a fluid out of the fat cell and through the opening. In addition, by applying ultrasound energy to fat cells to increase the temperature to between 43 degrees and 49 degrees, cell apoptosis can be realized, thereby resulting in reduction of fat.

20 Claims, 27 Drawing Sheets

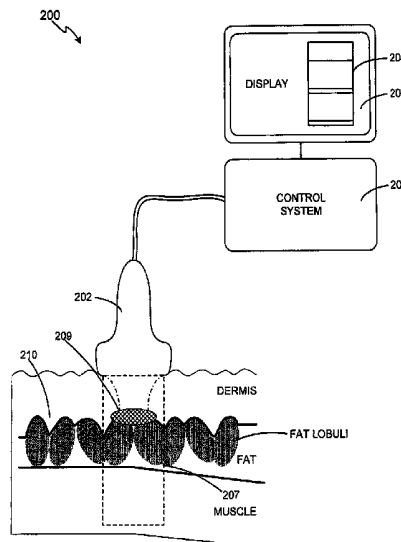

Related U.S. Application Data					
	continuation-in-part of application No. 11/163,154, filed on Oct. 6, 2005, now Pat. No. 8,133,180.	4,807,633 A	2/1989	Fry	
		4,817,615 A	4/1989	Fukukita et al.	
		4,858,613 A	8/1989	Fry	
		4,860,732 A	8/1989	Hasegawa et al.	
		4,865,041 A	9/1989	Hassler	
(60)	Provisional application No. 60/616,753, filed on Oct. 6, 2004, provisional application No. 61/140,725, filed on Dec. 24, 2008.	4,865,042 A	9/1989	Umemura	
		4,867,169 A	9/1989	Machida	
		4,874,562 A	10/1989	Hyon	
		4,875,487 A	10/1989	Seppi	
		4,881,212 A	11/1989	Takeuchi	
		4,891,043 A	1/1990	Zeimer et al.	
		4,893,624 A	1/1990	Lele	
		4,896,673 A	1/1990	Rose	
		4,900,540 A	2/1990	Ryan et al.	
		4,901,729 A	2/1990	Saitoh	
		4,917,096 A	4/1990	Englehart	
(51)	Int. Cl.	4,932,414 A *	6/1990	Coleman	A61B 8/14 128/916
	<i>A61B 5/00</i> (2006.01)				
	<i>A61N 7/02</i> (2006.01)				
	<i>B06B 1/06</i> (2006.01)				
	<i>G01S 7/52</i> (2006.01)				
	<i>G01S 15/89</i> (2006.01)				
	<i>A61B 8/08</i> (2006.01)				
	<i>A61B 8/14</i> (2006.01)	4,938,216 A	7/1990	Lele	
	<i>A61B 19/00</i> (2006.01)	4,938,217 A	7/1990	Lele	
		4,947,046 A	8/1990	Kawabata et al.	
(52)	U.S. Cl.	4,951,653 A	8/1990	Fry	
	CPC <i>G01S 15/899</i> (2013.01); <i>G01S 15/8993</i> (2013.01); <i>A61B 8/0858</i> (2013.01); <i>A61B 8/14</i> (2013.01); <i>A61B 8/4455</i> (2013.01); <i>A61B 2019/5276</i> (2013.01); <i>A61N 2007/0008</i> (2013.01); <i>A61N 2007/0052</i> (2013.01)	4,955,365 A	9/1990	Fry	
		4,958,626 A	9/1990	Nambu	
		4,976,709 A	12/1990	Sand	
		4,979,501 A	12/1990	Valchanov	
		4,992,989 A	2/1991	Watanabe et al.	
		5,012,797 A	5/1991	Liang	
		5,018,508 A *	5/1991	Fry	A61N 7/00 601/2
(56)	References Cited				
	U.S. PATENT DOCUMENTS	5,030,874 A	7/1991	Saito et al.	
		5,036,855 A	8/1991	Fry	
		5,040,537 A	8/1991	Katakura	
		5,054,310 A	10/1991	Flynn	
		5,054,470 A	10/1991	Fry	
		5,070,879 A	12/1991	Herres	
		5,088,495 A	2/1992	Miyagawa	
		5,115,814 A	5/1992	Griffith	
		5,117,832 A	6/1992	Sanghvi	
		5,123,418 A	6/1992	Saurel	
		5,143,063 A	9/1992	Fellner	
		5,143,074 A	9/1992	Dory	
		5,149,319 A	9/1992	Unger	
		5,150,711 A	9/1992	Dory	
		5,150,714 A	9/1992	Green	
		5,152,294 A	10/1992	Mochizuki et al.	
		5,156,144 A	10/1992	Iwasaki	
		5,158,536 A	10/1992	Sekins	
		5,159,931 A	11/1992	Pini	
		5,163,421 A	11/1992	Bernstein	
		5,163,436 A	11/1992	Saitoh et al.	
		5,178,135 A	1/1993	Uchiyama et al.	
		5,190,518 A	3/1993	Takasu	
		5,190,766 A	3/1993	Ishihara	
		5,191,880 A	3/1993	McLeod	
		5,205,287 A	4/1993	Erbel et al.	
		5,209,720 A	5/1993	Unger	
		5,212,671 A	5/1993	Fujii et al.	
		5,215,680 A	6/1993	D'Arrigo	
		5,224,467 A	7/1993	Oku	
		5,230,334 A	7/1993	Klopotek	
		5,230,338 A	7/1993	Allen et al.	
		5,247,924 A	9/1993	Suzuki et al.	
		5,255,681 A	10/1993	Ishimura et al.	
		5,257,970 A	11/1993	Dougherty	
		5,265,614 A	11/1993	Hayakawa	
		5,267,985 A	12/1993	Shimada	
		5,269,297 A	12/1993	Weng	
		5,282,797 A	2/1994	Chess	
		5,295,484 A	3/1994	Marcus	
		5,295,486 A	3/1994	Wollschlager et al.	
		5,304,169 A	4/1994	Sand	
		5,305,756 A	4/1994	Entrekin et al.	
		5,321,520 A	6/1994	Inga et al.	
		5,323,779 A	6/1994	Hardy et al.	
		5,327,895 A	7/1994	Hashimoto et al.	
		5,348,016 A	9/1994	Unger et al.	
		5,360,268 A	11/1994	Hayashi	
		5,370,121 A	12/1994	Reichenberger	

(56)

References Cited

U.S. PATENT DOCUMENTS

5,371,483 A	12/1994	Bhardwaj	5,694,936 A	12/1997	Fujimoto
5,375,602 A	12/1994	Lancee et al.	5,697,897 A	12/1997	Buchholtz
5,379,773 A	1/1995	Hornsby	5,701,900 A	12/1997	Shehada et al.
5,380,280 A	1/1995	Peterson	5,704,361 A	1/1998	Seward et al.
5,380,519 A	1/1995	Schneider et al.	5,706,252 A	1/1998	Le Verrier et al.
5,383,917 A	1/1995	Desai et al.	5,706,564 A	1/1998	Rhyne
5,391,140 A	2/1995	Schaetzle et al.	5,715,823 A	2/1998	Wood et al.
5,391,197 A	2/1995	Burdette et al.	5,720,287 A	2/1998	Chapelon et al.
5,392,259 A	2/1995	Bolorforosh	5,722,411 A	3/1998	Suzuki
5,396,143 A	3/1995	Seyed-Bolorforosh et al.	5,727,554 A	3/1998	Kalend et al.
5,398,689 A	3/1995	Connor et al.	5,735,280 A	4/1998	Sherman et al.
5,406,503 A	4/1995	Williams	5,743,863 A	4/1998	Chapelon
5,417,216 A	5/1995	Tanaka	5,746,005 A	5/1998	Steinberg
5,419,327 A	5/1995	Rohwedder	5,746,762 A	5/1998	Bass
5,423,220 A	6/1995	Finsterwald et al.	5,748,767 A	5/1998	Raab
5,435,311 A	7/1995	Umemura	5,749,364 A	5/1998	Sliwa et al.
5,438,998 A	8/1995	Hanafy	5,755,228 A	5/1998	Wilson et al.
5,458,596 A	10/1995	Lax	5,755,753 A	5/1998	Knowlton
5,460,179 A	10/1995	Okunuki et al.	5,762,066 A	6/1998	Law
5,460,595 A	10/1995	Hall et al.	5,763,886 A	6/1998	Schulte
5,469,854 A	11/1995	Unger et al.	5,769,790 A	6/1998	Watkins
5,471,988 A	12/1995	Fujio	5,779,644 A	7/1998	Eberle et al.
5,487,388 A	1/1996	Rello et al.	5,792,058 A	8/1998	Lee
5,492,126 A	2/1996	Hennige	5,795,297 A	8/1998	Daigle
5,496,256 A	3/1996	Bock	5,795,311 A	8/1998	Wess
5,501,655 A	3/1996	Rolt	5,810,009 A	9/1998	Mine et al.
5,503,152 A	4/1996	Oakley et al.	5,810,888 A	9/1998	Fenn
5,503,320 A	4/1996	Webster et al.	5,814,599 A	9/1998	Mitragotri et al.
5,507,790 A	4/1996	Weiss	5,817,013 A	10/1998	Ginn et al.
5,511,296 A	4/1996	Dias et al.	5,817,021 A	10/1998	Reichenberger
5,520,188 A	5/1996	Hennige	5,820,564 A	10/1998	Slayton
5,522,869 A	6/1996	Burdette	5,823,962 A	10/1998	Schaetzle
5,523,058 A	6/1996	Umemura et al.	5,827,204 A	10/1998	Grandia et al.
5,524,620 A	6/1996	Rosenchein	5,839,751 A	11/1998	Bonin
5,524,624 A	6/1996	Tepper	5,840,032 A	11/1998	Hatfield et al.
5,524,625 A	6/1996	Okazaki	5,844,140 A	12/1998	Seale
5,526,624 A	6/1996	Berg	5,853,367 A	12/1998	Chalek et al.
5,526,812 A	6/1996	Dumoulin et al.	5,869,751 A	2/1999	Bonin
5,526,814 A	6/1996	Cline et al.	5,871,524 A	2/1999	Knowlton
5,526,815 A	6/1996	Granz	5,873,902 A	2/1999	Sanghvi
5,529,070 A	6/1996	Augustine et al.	5,876,341 A	3/1999	Wang et al.
5,540,235 A	7/1996	Wilson	5,879,303 A	3/1999	Averkiou et al.
5,558,092 A	9/1996	Unger	5,882,557 A	3/1999	Hayakawa
5,560,362 A	10/1996	Sliwa et al.	5,891,034 A	4/1999	Bucholz
5,575,291 A	11/1996	Hayakawa	5,895,356 A	4/1999	Andrus et al.
5,575,807 A	11/1996	Faller	5,899,861 A	5/1999	Friemel et al.
5,577,502 A	11/1996	Darrow et al.	5,904,659 A	5/1999	Duarte
5,577,507 A	11/1996	Snyder et al.	5,919,219 A	7/1999	Knowlton
5,577,991 A	11/1996	Akui et al.	5,923,099 A	7/1999	Bilir
5,580,575 A	12/1996	Unger et al.	5,924,989 A	7/1999	Polz
5,601,526 A	2/1997	Chapelon	5,928,169 A	7/1999	Schatzle et al.
5,603,323 A	2/1997	Pflugrath et al.	5,931,805 A	8/1999	Brisken
5,609,562 A	3/1997	Kaali	5,938,606 A	8/1999	Bonnefous
5,615,091 A	3/1997	Palatnik	5,938,612 A	8/1999	Kline-Schoder
5,617,858 A	4/1997	Taverna et al.	5,948,011 A	9/1999	Knowlton
5,618,275 A	4/1997	Bock	5,957,844 A	9/1999	Dekel
5,620,479 A	4/1997	Diederich	5,957,882 A	9/1999	Nita et al.
5,622,175 A	4/1997	Sudol et al.	5,957,941 A	9/1999	Ream
5,638,819 A	6/1997	Manwaring et al.	5,964,707 A	10/1999	Fenster et al.
5,643,179 A	7/1997	Fujimoto	5,967,980 A	10/1999	Ferre et al.
5,644,085 A	7/1997	Lorraine et al.	5,968,034 A	10/1999	Fullmer
5,647,373 A	7/1997	Paltieli	5,971,949 A	10/1999	Levin
5,655,535 A	8/1997	Friemel et al.	5,977,538 A	11/1999	Unger et al.
5,655,538 A	8/1997	Lorraine	5,984,882 A	11/1999	Rosenchein
5,657,760 A	8/1997	Ying	5,990,598 A	11/1999	Sudol et al.
5,658,328 A	8/1997	Johnson	5,997,471 A	12/1999	Gumb et al.
5,660,836 A	8/1997	Knowlton	5,997,497 A	12/1999	Nita et al.
5,662,116 A	9/1997	Kondo	5,999,843 A	12/1999	Anbar
5,665,053 A	9/1997	Jacobs	6,004,262 A	12/1999	Putz et al.
5,665,141 A	9/1997	Vago	6,007,499 A	12/1999	Martin et al.
5,671,746 A	9/1997	Dreschel et al.	6,013,032 A	1/2000	Savord
5,673,699 A	10/1997	Trahey et al.	6,016,255 A	1/2000	Bolan et al.
5,676,692 A	10/1997	Sanghvi	6,019,724 A	2/2000	Gronningsaeter et al.
5,685,820 A	11/1997	Riek et al.	6,022,308 A	2/2000	Williams
5,690,608 A	11/1997	Watanabe	6,022,327 A	2/2000	Chang
			6,036,646 A	3/2000	Barthe
			6,039,048 A	3/2000	Silberg
			6,039,689 A	3/2000	Lizzi
			6,042,556 A	3/2000	Beach

(56)

References Cited

U.S. PATENT DOCUMENTS

6,049,159	A	4/2000	Barthe	6,425,867	B1	7/2002	Vaezy	
6,050,943	A	4/2000	Slayton	6,425,912	B1	7/2002	Knowlton	
6,059,727	A	5/2000	Fowlkes	6,428,477	B1	8/2002	Mason	
6,071,239	A	6/2000	Cribbs	6,428,532	B1	8/2002	Doukas	
6,080,108	A	6/2000	Dunham	6,430,446	B1	8/2002	Knowlton	
6,083,148	A	7/2000	Williams	6,432,057	B1	8/2002	Mazess et al.	
6,086,535	A	7/2000	Ishibashi	6,432,067	B1	8/2002	Martin	
6,086,580	A	7/2000	Mordon et al.	6,432,101	B1	8/2002	Weber	
6,090,054	A	7/2000	Tagishi	6,436,061	B1	8/2002	Costantino	
6,093,883	A	7/2000	Sanghvi	6,438,424	B1	8/2002	Knowlton	
6,101,407	A	8/2000	Groezinger	6,440,071	B1	8/2002	Slayton	
6,106,469	A	8/2000	Suzuki et al.	6,440,121	B1	8/2002	Weber	
6,113,558	A	9/2000	Rosenchein	6,443,914	B1 *	9/2002	Costantino	A61M 25/0026 601/2
6,113,559	A	9/2000	Klopotek	6,447,443	B1	9/2002	Keogh et al.	
6,120,452	A	9/2000	Barthe	6,451,013	B1	9/2002	Bays et al.	
6,123,081	A	9/2000	Durette	6,453,202	B1	9/2002	Knowlton	
6,126,619	A	10/2000	Peterson et al.	6,461,378	B1	10/2002	Knowlton	
6,135,971	A	10/2000	Hutchinson	6,470,216	B1	10/2002	Knowlton	
6,139,499	A	10/2000	Wilk	6,488,626	B1	12/2002	Lizzi	
6,159,150	A	12/2000	Yale et al.	6,491,657	B2	12/2002	Rowe	
6,171,244	B1	1/2001	Finger et al.	6,500,121	B1	12/2002	Slayton	
6,176,840	B1	1/2001	Nishimura	6,500,141	B1	12/2002	Irion	
6,183,426	B1	2/2001	Akisada	6,506,171	B1	1/2003	Vitek et al.	
6,183,502	B1	2/2001	Takeuchi	6,508,774	B1	1/2003	Acker	
6,183,773	B1	2/2001	Anderson	6,511,427	B1	1/2003	Sliwa, Jr. et al.	
6,190,323	B1	2/2001	Dias	6,511,428	B1 *	1/2003	Azuma	A61N 7/022 600/439
6,190,336	B1	2/2001	Duarte	6,514,244	B2	2/2003	Pope	
6,193,658	B1	2/2001	Wendelken	6,517,484	B1	2/2003	Wilk	
6,210,327	B1	4/2001	Brackett et al.	6,524,250	B1	2/2003	Weber	
6,213,948	B1	4/2001	Barthe	6,540,679	B2	4/2003	Slayton	
6,216,029	B1	4/2001	Paltieli	6,540,685	B1	4/2003	Rhoads et al.	
6,233,476	B1	5/2001	Strommer et al.	6,540,700	B1	4/2003	Fujimoto et al.	
6,234,990	B1	5/2001	Rowe et al.	6,547,788	B1	4/2003	Maguire et al.	
6,241,753	B1	6/2001	Knowlton	6,554,771	B1	4/2003	Buil et al.	
6,246,898	B1	6/2001	Vesely et al.	6,569,099	B1	5/2003	Babaev	
6,251,074	B1	6/2001	Averkiou et al.	6,569,108	B2	5/2003	Sarvazyan et al.	
6,251,088	B1	6/2001	Kaufman et al.	6,572,552	B2	6/2003	Fukukita	
6,268,405	B1	7/2001	Yao	6,575,956	B1	6/2003	Brisken et al.	
6,273,864	B1	8/2001	Duarte	6,595,934	B1 *	7/2003	Hissong	A61N 7/02 601/3
6,280,402	B1	8/2001	Ishibashi et al.	6,599,256	B1	7/2003	Acker	
6,287,257	B1	9/2001	Matichuk	6,605,080	B1	8/2003	Altshuler et al.	
6,287,304	B1	9/2001	Eggers et al.	6,607,498	B2	8/2003	Eshel	
6,296,619	B1	10/2001	Brisken	6,618,620	B1	9/2003	Freundlich et al.	
6,301,989	B1	10/2001	Brown et al.	6,623,430	B1	9/2003	Slayton	
6,307,302	B1	10/2001	Toda	6,626,854	B2	9/2003	Friedman	
6,309,355	B1	10/2001	Cain et al.	6,626,855	B1	9/2003	Weng	
6,311,090	B1	10/2001	Knowlton	6,638,226	B2	10/2003	He et al.	
6,315,741	B1 *	11/2001	Martin	6,645,150	B2	11/2003	Angelsen et al.	
			A61B 8/4461 601/3	6,645,162	B2	11/2003	Friedman	
6,322,509	B1	11/2001	Pan et al.	6,662,054	B2	12/2003	Kreindel	
6,322,532	B1	11/2001	D'Sa	6,663,627	B2	12/2003	Francischelli	
6,325,540	B1	12/2001	Lounsberry et al.	6,665,806	B1	12/2003	Shimizu	
6,325,758	B1	12/2001	Carol et al.	6,666,835	B2	12/2003	Martin	
6,325,769	B1	12/2001	Klopotek	6,669,638	B1	12/2003	Miller	
6,325,798	B1	12/2001	Edwards et al.	6,685,640	B1	2/2004	Fry	
6,338,716	B1	1/2002	Hossack et al.	6,692,450	B1	2/2004	Coleman	
6,350,276	B1	2/2002	Knowlton	6,699,237	B2	3/2004	Weber	
6,356,780	B1	3/2002	Licato et al.	6,716,184	B2	4/2004	Vaezy et al.	
6,361,531	B1	3/2002	Hissong	6,719,449	B1	4/2004	Laughlin	
6,370,411	B1	4/2002	Osadchy et al.	6,719,694	B2	4/2004	Weng	
6,375,672	B1	4/2002	Aksan	6,726,627	B1	4/2004	Lizzi et al.	
6,377,854	B1	4/2002	Knowlton	6,733,449	B1	5/2004	Krishnamurthy et al.	
6,377,855	B1	4/2002	Knowlton	6,749,624	B2	6/2004	Knowlton	
6,381,497	B1	4/2002	Knowlton	6,772,490	B2	8/2004	Toda	
6,381,498	B1	4/2002	Knowlton	6,773,409	B2	8/2004	Truckai et al.	
6,387,380	B1	5/2002	Knowlton	6,775,404	B1	8/2004	Pagoulatos et al.	
6,390,982	B1	5/2002	Bova et al.	6,790,187	B2	9/2004	Thompson et al.	
6,405,090	B1	6/2002	Knowlton	6,824,516	B2	11/2004	Batten et al.	
6,409,720	B1	6/2002	Hissong	6,835,940	B2	12/2004	Morikawa et al.	
6,413,216	B1	7/2002	Cain et al.	6,846,290	B2	1/2005	Lizzi et al.	
6,413,253	B1	7/2002	Koop	6,875,176	B2	4/2005	Mourad	
6,413,254	B1	7/2002	Hissong	6,882,884	B1	4/2005	Mosk et al.	
6,419,648	B1	7/2002	Vitek	6,887,239	B2	5/2005	Elstrom	
6,423,007	B2	7/2002	Lizzi et al.	6,889,089	B2	5/2005	Behl	
6,425,865	B1	7/2002	Salcudean	6,896,657	B2	5/2005	Willis	
				6,902,536	B2	6/2005	Manna	

(56)

References Cited

U.S. PATENT DOCUMENTS

6,905,466 B2	6/2005	Salgo	7,828,734 B2	11/2010	Azhari et al.
6,918,907 B2	7/2005	Kelly	7,833,162 B2	11/2010	Hasegawa et al.
6,920,883 B2	7/2005	Besette	7,841,984 B2	11/2010	Cribbs et al.
6,921,371 B2	7/2005	Wilson	7,846,096 B2	12/2010	Mast et al.
6,932,771 B2	8/2005	Whitmore	7,857,773 B2	12/2010	Desilets et al.
6,932,814 B2	8/2005	Wood	7,875,023 B2	1/2011	Eshel et al.
6,936,044 B2	8/2005	McDaniel	7,901,359 B2	3/2011	Mandrusov et al.
6,936,046 B2	8/2005	Hissong	7,905,007 B2	3/2011	Calisti et al.
6,945,937 B2	9/2005	Culp et al.	7,905,844 B2	3/2011	Desilets et al.
6,948,843 B2	9/2005	Laugharn et al.	7,914,453 B2	3/2011	Slayton et al.
6,953,941 B2	10/2005	Nakano et al.	7,914,469 B2	3/2011	Torbati
6,958,043 B2	10/2005	Hissong	7,931,611 B2	4/2011	Rovak et al.
6,971,994 B1	12/2005	Young et al.	7,955,262 B2	6/2011	Rosenberg
6,974,417 B2	12/2005	Lockwood	7,955,281 B2	6/2011	Pedersen et al.
6,976,492 B2	12/2005	Ingle	7,967,764 B2	6/2011	Lidgren et al.
6,992,305 B2	1/2006	Maezawa et al.	7,967,839 B2	6/2011	Flock et al.
6,997,923 B2	2/2006	Anderson	7,993,289 B2	8/2011	Quistgaard et al.
7,006,874 B2	2/2006	Knowlton	8,057,389 B2	11/2011	Barthe et al.
7,020,528 B2	3/2006	Neev	8,057,465 B2	11/2011	Sliwa, Jr. et al.
7,022,089 B2	4/2006	Ooba	8,066,641 B2	11/2011	Barthe et al.
7,058,440 B2	6/2006	Heuscher et al.	8,123,707 B2	2/2012	Huckle et al.
7,063,666 B2	6/2006	Weng	8,128,618 B2	3/2012	Gliklich et al.
7,070,565 B2	7/2006	Vaezy et al.	8,133,180 B2	3/2012	Slayton et al.
7,074,218 B2	7/2006	Washington et al.	8,133,191 B2	3/2012	Rosenberg et al.
7,094,252 B2	8/2006	Koop	8,142,200 B2	3/2012	Crunkilton et al.
7,108,663 B2	9/2006	Talish et al.	8,152,904 B2	4/2012	Slobodzian et al.
7,115,123 B2	10/2006	Knowlton	8,162,858 B2	4/2012	Manna et al.
7,122,029 B2	10/2006	Koop et al.	8,166,332 B2	4/2012	Barthe et al.
7,142,905 B2	11/2006	Slayton	8,182,428 B2	5/2012	Angelsen et al.
7,165,451 B1	1/2007	Brooks et al.	8,197,409 B2	6/2012	Foley et al.
7,179,238 B2	2/2007	Hissong	8,206,299 B2	6/2012	Foley et al.
7,189,230 B2	3/2007	Knowlton	8,208,346 B2	6/2012	Crunkilton
7,229,411 B2	6/2007	Slayton	8,211,017 B2	7/2012	Foley et al.
7,235,592 B2	6/2007	Muratoglu	8,262,591 B2	9/2012	Pedersen et al.
7,258,674 B2	8/2007	Cribbs	8,262,650 B2	9/2012	Zanelli et al.
7,273,459 B2	9/2007	Desilets	8,264,126 B2	9/2012	Toda et al.
7,294,125 B2	11/2007	Phalen et al.	8,273,037 B2	9/2012	Kreindel et al.
7,297,117 B2	11/2007	Trucco	8,282,554 B2	10/2012	Makin et al.
7,303,555 B2	12/2007	Makin et al.	8,292,835 B1	10/2012	Cimino
7,311,679 B2	12/2007	Desilets et al.	8,298,163 B1	10/2012	Cimino
7,327,071 B2	2/2008	Nishiyama et al.	8,333,700 B1	12/2012	Barthe et al.
7,331,951 B2	2/2008	Eshel et al.	8,334,637 B2	12/2012	Crunkilton et al.
7,332,985 B2	2/2008	Larson et al.	8,337,407 B2	12/2012	Quistgaard et al.
7,338,434 B1	3/2008	Haarstad et al.	8,343,051 B2	1/2013	Desilets et al.
7,347,855 B2	3/2008	Eshel	8,366,622 B2	2/2013	Slayton et al.
RE40,403 E	6/2008	Cho et al.	8,388,535 B2	3/2013	Weng et al.
7,393,325 B2	7/2008	Barthe	8,409,097 B2	4/2013	Slayton et al.
7,398,116 B2	7/2008	Edwards	8,425,435 B2	4/2013	Wing et al.
7,399,279 B2	7/2008	Abend et al.	8,444,562 B2	5/2013	Barthe et al.
7,491,171 B2	2/2009	Barthe et al.	8,454,540 B2	6/2013	Eshel et al.
7,507,235 B2	3/2009	Keogh et al.	8,460,193 B2	6/2013	Barthe et al.
7,510,536 B2	3/2009	Foley et al.	8,480,585 B2	7/2013	Slayton et al.
7,517,315 B2	4/2009	Willis	8,506,486 B2	8/2013	Slayton et al.
7,530,356 B2	5/2009	Slayton	8,512,250 B2	8/2013	Quistgaard et al.
7,530,958 B2	5/2009	Slayton	8,523,775 B2	9/2013	Barthe et al.
7,532,201 B2	5/2009	Quistgaard et al.	8,535,228 B2	9/2013	Slayton et al.
7,571,336 B2	8/2009	Barthe	8,570,837 B2	10/2013	Toda et al.
7,601,120 B2	10/2009	Moilanen et al.	8,573,392 B2	11/2013	Bennett et al.
7,615,015 B2	11/2009	Coleman	8,583,211 B2	11/2013	Salomir et al.
7,615,016 B2	11/2009	Barthe	8,585,618 B2	11/2013	Hunziker et al.
7,652,411 B2	1/2010	Crunkilton et al.	8,604,672 B2	12/2013	Toda et al.
7,662,114 B2	2/2010	Seip et al.	8,622,937 B2	1/2014	Weng et al.
7,674,257 B2	3/2010	Pless et al.	8,636,665 B2	1/2014	Slayton et al.
7,686,763 B2	3/2010	Vaezy et al.	8,641,622 B2	2/2014	Barthe et al.
7,694,406 B2	4/2010	Wildes et al.	8,663,112 B2	3/2014	Slayton et al.
7,695,437 B2	4/2010	Quistgaard et al.	8,672,848 B2	3/2014	Slayton et al.
7,713,203 B2	5/2010	Lacoste et al.	8,690,778 B2	4/2014	Slayton et al.
7,727,156 B2	6/2010	Angelsen et al.	8,690,779 B2	4/2014	Slayton et al.
7,758,524 B2	7/2010	Barthe	8,690,780 B2	4/2014	Slayton et al.
7,766,848 B2	8/2010	Desilets et al.	8,708,935 B2	4/2014	Barthe et al.
7,789,841 B2	9/2010	Huckle et al.	8,715,186 B2	5/2014	Slayton et al.
7,806,839 B2	10/2010	Mast et al.	8,726,781 B2	5/2014	Eckhoff et al.
7,815,570 B2	10/2010	Eshel et al.	8,728,071 B2	5/2014	Lischinsky et al.
7,819,826 B2	10/2010	Diederich et al.	8,753,295 B2	6/2014	Thierman
7,824,348 B2	11/2010	Barthe	8,758,253 B2	6/2014	Sano et al.
			8,836,203 B2	9/2014	Nobles et al.
			8,857,438 B2	10/2014	Barthe et al.
			8,858,471 B2	10/2014	Barthe et al.
			8,915,853 B2	12/2014	Barthe et al.

(56)

References Cited

U.S. PATENT DOCUMENTS

8,915,854	B2	12/2014	Slayton et al.	2003/0212393	A1	11/2003	Knowlton	
8,915,870	B2	12/2014	Barthe et al.	2003/0216648	A1	11/2003	Lizzi et al.	
8,920,320	B2	12/2014	Stecco et al.	2003/0216795	A1	11/2003	Harth	
8,920,324	B2	12/2014	Slayton et al.	2003/0220536	A1	11/2003	Hissong	
8,926,533	B2	1/2015	Bockenstedt et al.	2003/0220585	A1	11/2003	Hissong	
8,932,224	B2	1/2015	Barthe et al.	2003/0229331	A1	12/2003	Brisken et al.	
8,932,238	B2	1/2015	Wing et al.	2003/0233085	A1	12/2003	Giammarusti	
8,968,205	B2	3/2015	Zeng et al.	2003/0236487	A1	12/2003	Knowlton	
9,011,336	B2	4/2015	Slayton et al.	2004/0000316	A1	1/2004	Knowlton	
9,039,619	B2	5/2015	Barthe et al.	2004/0001809	A1	1/2004	Brisken	
9,095,697	B2	8/2015	Barthe et al.	2004/0002705	A1	1/2004	Knowlton	
2001/0009997	A1	7/2001	Pope	2004/0010222	A1	1/2004	Nunomura et al.	
2001/0009999	A1	7/2001	Kaufman et al.	2004/0015079	A1	1/2004	Berger et al.	
2001/0014780	A1	8/2001	Martin	2004/0015106	A1	1/2004	Coleman	
2001/0014819	A1	8/2001	Ingle	2004/0030227	A1	2/2004	Littrup	
2001/0031922	A1	10/2001	Weng	2004/0039312	A1	2/2004	Hillstead	
2001/0039380	A1	11/2001	Larson et al.	2004/0039418	A1	2/2004	Elstrom et al.	
2001/0041880	A1	11/2001	Brisken	2004/0041563	A1	3/2004	Lewin et al.	
2002/0000763	A1	1/2002	Jones	2004/0041880	A1	3/2004	Ikeda et al.	
2002/0002345	A1	1/2002	Marlinghaus	2004/0042168	A1	3/2004	Yang et al.	
2002/0040199	A1	4/2002	Klopotek	2004/0044375	A1	3/2004	Diederich et al.	
2002/0040442	A1	4/2002	Ishidera	2004/0049134	A1	3/2004	Tosaya et al.	
2002/0055702	A1	5/2002	Atala	2004/0049734	A1	3/2004	Tosaya et al.	
2002/0062077	A1	5/2002	Emmenegger	2004/0059266	A1	3/2004	Fry	
2002/0062142	A1	5/2002	Knowlton	2004/0068186	A1	4/2004	Ishida et al.	
2002/0072691	A1	6/2002	Thompson et al.	2004/0073079	A1	4/2004	Altshuler et al.	
2002/0082528	A1	6/2002	Friedman	2004/0073113	A1	4/2004	Salgo	
2002/0082529	A1	6/2002	Suorsa et al.	2004/0073115	A1*	4/2004	Horzewski	H04N 1/58 600/439
2002/0082589	A1	6/2002	Friedman	2004/0073116	A1	4/2004	Smith	
2002/0087080	A1	7/2002	Slayton	2004/0073204	A1	4/2004	Ryan et al.	
2002/0095143	A1	7/2002	Key	2004/0077977	A1	4/2004	Ella et al.	
2002/0099094	A1	7/2002	Anderson	2004/0082857	A1	4/2004	Schonenberger	
2002/0115917	A1	8/2002	Honda et al.	2004/0082859	A1	4/2004	Schaer	
2002/0128639	A1	9/2002	Pless et al.	2004/0102697	A1	5/2004	Evron	
2002/0128648	A1	9/2002	Weber	2004/0105559	A1	6/2004	Aylward et al.	
2002/0143252	A1	10/2002	Dunne et al.	2004/0106867	A1	6/2004	Eshel et al.	
2002/0156400	A1	10/2002	Babaev	2004/0122323	A1	6/2004	Vortman et al.	
2002/0161357	A1	10/2002	Anderson	2004/0122493	A1	6/2004	Ishibashi et al.	
2002/0165529	A1	11/2002	Danek	2004/0143297	A1	7/2004	Ramsey	
2002/0168049	A1	11/2002	Schriever	2004/0152982	A1	8/2004	Hwang et al.	
2002/0169394	A1	11/2002	Eppstein et al.	2004/0158150	A1	8/2004	Rabiner et al.	
2002/0169442	A1	11/2002	Neev	2004/0186535	A1	9/2004	Knowlton	
2002/0173721	A1	11/2002	Grunwald et al.	2004/0189155	A1	9/2004	Funakubo	
2002/0193784	A1*	12/2002	McHale	2004/0206365	A1	10/2004	Knowlton	
			A61K 41/00 606/27	2004/0210214	A1	10/2004	Knowlton	
				2004/0217675	A1*	11/2004	Desilets	A61B 8/00 310/367
2002/0193831	A1	12/2002	Smith	2004/0249318	A1	12/2004	Tanaka	
2003/0009153	A1	1/2003	Brisken et al.	2004/0254620	A1	12/2004	Lacoste	
2003/0014039	A1	1/2003	Barzell et al.	2004/0267252	A1	12/2004	Washington et al.	
2003/0018255	A1	1/2003	Martin	2005/0033201	A1	2/2005	Takahashi	
2003/0028111	A1	2/2003	Vaezy et al.	2005/0033316	A1	2/2005	Kertz	
2003/0028113	A1	2/2003	Gilbert et al.	2005/0038340	A1	2/2005	Vaezy et al.	
2003/0032900	A1	2/2003	Ella	2005/0055018	A1	3/2005	Kreindel	
2003/0036706	A1	2/2003	Slayton et al.	2005/0055073	A1	3/2005	Weber	
2003/0040739	A1	2/2003	Koop	2005/0061834	A1	3/2005	Garcia et al.	
2003/0050678	A1	3/2003	Sierra	2005/0070961	A1	3/2005	Maki	
2003/0055417	A1	3/2003	Truckai et al.	2005/0074407	A1	4/2005	Smith	
2003/0060736	A1	3/2003	Martin et al.	2005/0080469	A1	4/2005	Larson	
2003/0065313	A1	4/2003	Koop	2005/0091770	A1	5/2005	Mourad et al.	
2003/0073907	A1	4/2003	Taylor	2005/0096542	A1	5/2005	Weng at al.	
2003/0074023	A1	4/2003	Kaplan	2005/0104690	A1	5/2005	Larson et al.	
2003/0083536	A1	5/2003	Eshel	2005/0113689	A1	5/2005	Gritzky	
2003/0092988	A1	5/2003	Makin	2005/0131302	A1	6/2005	Poland	
2003/0097071	A1	5/2003	Halmann et al.	2005/0137656	A1	6/2005	Malak	
2003/0099383	A1	5/2003	Lefebvre	2005/0143677	A1	6/2005	Young et al.	
2003/0125629	A1	7/2003	Ustuner	2005/0154313	A1	7/2005	Desilets	
2003/0135135	A1	7/2003	Miwa et al.	2005/0154314	A1	7/2005	Quistgaard	
2003/0139790	A1	7/2003	Ingle et al.	2005/0154332	A1	7/2005	Zanelli	
2003/0153961	A1	8/2003	Babaev	2005/0154431	A1	7/2005	Quistgaard	
2003/0171678	A1	9/2003	Batten et al.	2005/0187495	A1	8/2005	Quistgaard	
2003/0171701	A1	9/2003	Babaev	2005/0191252	A1	9/2005	Mitsui	
2003/0176790	A1	9/2003	Slayton	2005/0193451	A1	9/2005	Quistgaard	
2003/0191396	A1	10/2003	Sanghvi	2005/0197681	A1	9/2005	Barolet et al.	
2003/0200481	A1	10/2003	Stanley	2005/0228281	A1	10/2005	Nefos	
2003/0212129	A1	11/2003	Liu et al.	2005/0240170	A1	10/2005	Zhang et al.	
2003/0212351	A1	11/2003	Hissong	2005/0251120	A1*	11/2005	Anderson	A61B 5/6804 606/20

(56)

References Cited

U.S. PATENT DOCUMENTS

2005/0251125	A1	11/2005	Pless et al.	2008/0183110	A1	7/2008	Davenport et al.
2005/0256406	A1	11/2005	Barthe	2008/0188745	A1	8/2008	Chen et al.
2005/0261584	A1	11/2005	Eshel	2008/0194964	A1	8/2008	Randall et al.
2005/0261585	A1	11/2005	Makin et al.	2008/0195000	A1	8/2008	Spooner et al.
2005/0267454	A1	12/2005	Hissong	2008/0200810	A1	8/2008	Buchalter
2005/0288748	A1	12/2005	Li et al.	2008/0200813	A1	8/2008	Quistgaard
2006/0004306	A1	1/2006	Altshuler	2008/0214966	A1	9/2008	Slayton
2006/0020260	A1	1/2006	Dover et al.	2008/0221491	A1	9/2008	Slayton
2006/0025756	A1	2/2006	Francischelli	2008/0223379	A1	9/2008	Stuker et al.
2006/0042201	A1	3/2006	Curry	2008/0242991	A1	10/2008	Moon et al.
2006/0058664	A1	3/2006	Barthe et al.	2008/0243035	A1	10/2008	Crunkilton
2006/0058671	A1	3/2006	Vitek et al.	2008/0269608	A1	10/2008	Anderson et al.
2006/0058707	A1	3/2006	Barthe	2008/0275342	A1	11/2008	Barthe
2006/0058712	A1	3/2006	Altshuler et al.	2008/0281206	A1	11/2008	Bartlett et al.
2006/0074309	A1	4/2006	Bonnefous	2008/0281236	A1	11/2008	Eshel et al.
2006/0074313	A1	4/2006	Slayton et al.	2008/0281237	A1	11/2008	Slayton
2006/0074314	A1	4/2006	Slayton	2008/0281255	A1	11/2008	Slayton
2006/0074355	A1	4/2006	Slayton	2008/0294073	A1	11/2008	Barthe
2006/0079816	A1	4/2006	Barthe	2008/0319356	A1	12/2008	Cain
2006/0079868	A1	4/2006	Makin	2009/0005680	A1	1/2009	Jones et al.
2006/0084891	A1	4/2006	Barthe	2009/0012394	A1	1/2009	Hobelsberger et al.
2006/0089632	A1	4/2006	Barthe	2009/0043198	A1	2/2009	Milner et al.
2006/0089688	A1	4/2006	Panescu	2009/0043293	A1	2/2009	Pankratov et al.
2006/0094988	A1	5/2006	Tosaya	2009/0048514	A1	2/2009	Azhari et al.
2006/0111744	A1	5/2006	Makin	2009/0069677	A1	3/2009	Chen et al.
2006/0116583	A1	6/2006	Ogasawara et al.	2009/0093737	A1	4/2009	Chomas et al.
2006/0116671	A1	6/2006	Slayton	2009/0156969	A1	6/2009	Santangelo
2006/0122508	A1	6/2006	Slayton	2009/0171252	A1	7/2009	Bockenstedt et al.
2006/0122509	A1	6/2006	Desilets	2009/0177122	A1	7/2009	Peterson
2006/0161062	A1	7/2006	Arditi et al.	2009/0177123	A1	7/2009	Peterson
2006/0184069	A1	8/2006	Vaitekunas	2009/0182231	A1	7/2009	Barthe et al.
2006/0184071	A1	8/2006	Klopotek	2009/0198157	A1	8/2009	Babaev et al.
2006/0189972	A1	8/2006	Grossman	2009/0216159	A1	8/2009	Slayton et al.
2006/0206105	A1	9/2006	Chopra	2009/0226424	A1	9/2009	Hsu
2006/0229514	A1	10/2006	Wiener	2009/0227910	A1	9/2009	Pedersen et al.
2006/0241440	A1	10/2006	Eshel	2009/0253988	A1	10/2009	Slayton et al.
2006/0241442	A1	10/2006	Barthe	2009/0281463	A1	11/2009	Chapelon et al.
2006/0241470	A1	10/2006	Novak et al.	2009/0312693	A1	12/2009	Thapliyal et al.
2006/0241576	A1	10/2006	Diederich et al.	2009/0318909	A1	12/2009	Debenedictis et al.
2006/0250046	A1	11/2006	Koizumi et al.	2010/0011236	A1	1/2010	Barthe et al.
2006/0282691	A1	12/2006	Barthe	2010/0022919	A1	1/2010	Peterson
2006/0291710	A1	12/2006	Wang et al.	2010/0022921	A1	1/2010	Seip et al.
2007/0032784	A1	2/2007	Gliklich et al.	2010/0022922	A1	1/2010	Barthe et al.
2007/0035201	A1	2/2007	Desilets	2010/0030076	A1	2/2010	Vortman et al.
2007/0055154	A1	3/2007	Torbati	2010/0042020	A1	2/2010	Ben-Ezra
2007/0055155	A1	3/2007	Owen et al.	2010/0049178	A1	2/2010	Deem et al.
2007/0055156	A1	3/2007	Desilets et al.	2010/0056925	A1	3/2010	Zhang et al.
2007/0065420	A1	3/2007	Johnson	2010/0100014	A1	4/2010	Eshel et al.
2007/0083120	A1	4/2007	Cain et al.	2010/0113983	A1	5/2010	Heckerman et al.
2007/0087060	A1	4/2007	Dietrich	2010/0130891	A1	5/2010	Taggart et al.
2007/0088245	A1	4/2007	Babaev et al.	2010/0160782	A1	6/2010	Slayton et al.
2007/0088346	A1	4/2007	Mirizzi et al.	2010/0160837	A1	6/2010	Hunziker et al.
2007/0161902	A1	7/2007	Dan	2010/0168576	A1	7/2010	Poland et al.
2007/0166357	A1	7/2007	Shaffer et al.	2010/0191120	A1	7/2010	Kraus et al.
2007/0167709	A1	7/2007	Slayton	2010/0241035	A1	9/2010	Barthe et al.
2007/0208253	A1	9/2007	Slayton	2010/0249602	A1	9/2010	Buckley et al.
2007/0219604	A1	9/2007	Yaroslaysky et al.	2010/0249669	A1	9/2010	Ulric et al.
2007/0219605	A1	9/2007	Yaroslaysky et al.	2010/0256489	A1	10/2010	Pedersen et al.
2007/0238994	A1	10/2007	Stecco et al.	2010/0274161	A1	10/2010	Azhari et al.
2007/0239075	A1	10/2007	Rosenberg	2010/0280420	A1	11/2010	Barthe et al.
2007/0239077	A1	10/2007	Azhari et al.	2010/0286518	A1	11/2010	Lee et al.
2007/0239079	A1	10/2007	Manstein et al.	2010/0312150	A1	12/2010	Douglas et al.
2007/0239142	A1	10/2007	Altshuler	2011/0040171	A1	2/2011	Foley et al.
2008/0027328	A1	1/2008	Klopotek	2011/0040190	A1	2/2011	Jahnke et al.
2008/0039724	A1	2/2008	Seip et al.	2011/0066084	A1	3/2011	Desilets et al.
2008/0071255	A1	3/2008	Barthe	2011/0087099	A1	4/2011	Eshel et al.
2008/0086054	A1	4/2008	Slayton	2011/0087255	A1	4/2011	McCormack et al.
2008/0086056	A1	4/2008	Chang et al.	2011/0112405	A1	5/2011	Barthe et al.
2008/0097214	A1	4/2008	Meyers et al.	2011/0144490	A1	6/2011	Davis et al.
2008/0097253	A1	4/2008	Pedersen et al.	2011/0178444	A1	7/2011	Slayton et al.
2008/0114251	A1	5/2008	Weymer et al.	2011/0178541	A1	7/2011	Azhari
2008/0139974	A1	6/2008	Da Silva	2011/0190745	A1	8/2011	Uebelhoer et al.
2008/0146970	A1	6/2008	Litman et al.	2011/0251524	A1	10/2011	Azhari et al.
2008/0167556	A1	7/2008	Thompson	2011/0251527	A1	10/2011	Kushculey et al.
2008/0183077	A1	7/2008	Moreau-Gobard et al.	2011/0270137	A1	11/2011	Goren et al.
				2011/0319793	A1	12/2011	Henrik et al.
				2012/0004549	A1	1/2012	Barthe et al.
				2012/0016239	A1	1/2012	Barthe et al.
				2012/0029353	A1	2/2012	Slayton et al.

(56)

References Cited

U.S. PATENT DOCUMENTS

2012/0035475 A1 2/2012 Barthe et al.
 2012/0035476 A1 2/2012 Barthe et al.
 2012/0046547 A1 2/2012 Barthe et al.
 2012/0053458 A1 3/2012 Barthe et al.
 2012/0111339 A1 5/2012 Barthe et al.
 2012/0123304 A1 5/2012 Rybyanets et al.
 2012/0136280 A1 5/2012 Rosenberg et al.
 2012/0136282 A1 5/2012 Rosenberg et al.
 2012/0143056 A1 6/2012 Slayton et al.
 2012/0143100 A1 6/2012 Jeong et al.
 2012/0165668 A1 6/2012 Slayton et al.
 2012/0165848 A1 6/2012 Slayton et al.
 2012/0191020 A1 7/2012 Vitek et al.
 2012/0197120 A1 8/2012 Makin et al.
 2012/0197121 A1 8/2012 Slayton et al.
 2012/0209150 A1 8/2012 Zeng et al.
 2012/0215105 A1 8/2012 Slayton et al.
 2012/0271202 A1 10/2012 Wisdom
 2012/0271294 A1 10/2012 Barthe et al.
 2012/0296240 A1 11/2012 Azhari et al.
 2012/0302883 A1 11/2012 Kong et al.
 2012/0316426 A1 12/2012 Foley et al.
 2012/0330197 A1 12/2012 Makin et al.
 2012/0330222 A1 12/2012 Makin et al.
 2012/0330223 A1 12/2012 Makin et al.
 2012/0330283 A1 12/2012 Hyde et al.
 2012/0330284 A1 12/2012 Hyde et al.
 2013/0012755 A1 1/2013 Slayton
 2013/0012816 A1 1/2013 Slayton et al.
 2013/0012838 A1 1/2013 Jaeger et al.
 2013/0012842 A1 1/2013 Barthe
 2013/0018285 A1 1/2013 Park et al.
 2013/0018286 A1 1/2013 Slayton et al.
 2013/0046209 A1 2/2013 Slayton et al.
 2013/0051178 A1 2/2013 Rybyanets
 2013/0060170 A1 3/2013 Lee et al.
 2013/0066208 A1 3/2013 Barthe et al.
 2013/0066237 A1 3/2013 Smotrich et al.
 2013/0072826 A1 3/2013 Slayton et al.
 2013/0096471 A1 4/2013 Slayton et al.
 2013/0190659 A1 7/2013 Slayton et al.
 2013/0211293 A1 8/2013 Auboiroux et al.
 2013/0225994 A1 8/2013 Hsu et al.
 2013/0274603 A1 10/2013 Barthe et al.
 2013/0281853 A1 10/2013 Slayton et al.
 2013/0281891 A1 10/2013 Slayton et al.
 2013/0296697 A1 11/2013 Slayton et al.
 2013/0296700 A1 11/2013 Slayton et al.
 2013/0303904 A1 11/2013 Barthe et al.
 2013/0303905 A1 11/2013 Barthe et al.
 2013/0310714 A1 11/2013 Eshel et al.
 2013/0310863 A1 11/2013 Makin et al.
 2013/0345562 A1 12/2013 Barthe et al.
 2014/0024974 A1 1/2014 Slayton et al.
 2014/0050054 A1 2/2014 Toda et al.
 2014/0081300 A1 3/2014 Melodelima et al.
 2014/0082907 A1 3/2014 Barthe et al.
 2014/0117814 A1 5/2014 Toda et al.
 2014/0142430 A1 5/2014 Slayton et al.
 2014/0148834 A1 5/2014 Barthe et al.
 2014/0180174 A1 6/2014 Slayton et al.
 2014/0187944 A1 7/2014 Slayton et al.
 2014/0188015 A1 7/2014 Slayton et al.
 2014/0188145 A1 7/2014 Slayton et al.
 2014/0194723 A1 7/2014 Herzog et al.
 2014/0208856 A1 7/2014 Schmid
 2014/0221823 A1 8/2014 Keogh et al.
 2014/0236049 A1 8/2014 Barthe et al.
 2014/0236061 A1 8/2014 Lee et al.
 2014/0243713 A1 8/2014 Slayton et al.
 2014/0257145 A1 9/2014 Emery
 2014/0276055 A1 9/2014 Barthe et al.
 2015/0000674 A1 1/2015 Barthe et al.
 2015/0080723 A1 3/2015 Barthe et al.
 2015/0080771 A1 3/2015 Barthe et al.

2015/0080874 A1 3/2015 Slayton et al.
 2015/0088182 A1 3/2015 Slayton et al.
 2015/0164734 A1 6/2015 Slayton et al.
 2015/0165238 A1 6/2015 Slayton et al.
 2015/0165243 A1 6/2015 Slayton et al.
 2015/0174388 A1 6/2015 Slayton

FOREIGN PATENT DOCUMENTS

DE 10140064 3/2003
 DE 10219297 11/2003
 DE 10219217 12/2004
 DE 20314479 12/2004
 EP 0142215 5/1984
 EP 0344773 12/1989
 EP 1479412 11/1991
 EP 0473553 4/1992
 EP 0661029 7/1995
 EP 1044038 10/2000
 EP 1050322 11/2000
 EP 1234566 8/2002
 EP 1262160 12/2002
 EP 1283690 2/2003
 EP 1374944 1/2004
 EP 1028660 1/2008
 EP 1874241 1/2008
 EP 1362223 5/2008
 EP 1750804 7/2008
 EP 1811901 4/2009
 EP 1785164 8/2009
 EP 2230904 9/2010
 EP 1501331 6/2011
 EP 2066405 11/2011
 EP 2474050 7/2012
 FR 2672486 8/1992
 GB 2113099 8/1983
 JP 63036171 2/1988
 JP 03048299 3/1991
 JP 3123559 5/1991
 JP 03136642 6/1991
 JP 4089058 3/1992
 JP 4-150847 5/1992
 JP 04150847 5/1992
 JP 7080087 3/1995
 JP 07505793 6/1995
 JP 2007505793 6/1995
 JP 7222782 8/1995
 JP 09047458 2/1997
 JP 9108288 4/1997
 JP 9503926 4/1997
 JP 11-505440 5/1999
 JP 11-506636 6/1999
 JP 2000166940 6/2000
 JP 2001170068 6/2001
 JP 2002-505596 2/2002
 JP 2002078764 3/2002
 JP 2002515786 5/2002
 JP 2002521118 7/2002
 JP 2002-537939 11/2002
 JP 2003050298 7/2003
 JP 2003204982 7/2003
 JP 2004-147719 5/2004
 JP 2005503388 2/2005
 JP 2005527336 9/2005
 JP 2005323213 11/2005
 JP 2006520247 9/2006
 JP 2008515559 5/2008
 JP 2009518126 5/2009
 JP 2010517695 5/2010
 KR 1020010024871 3/2001
 KR 100400870 10/2003
 KR 1020060113930 11/2006
 KR 1020070065332 6/2007
 KR 1020070070161 7/2007
 KR 1020070098856 10/2007
 KR 1020070104878 10/2007
 KR 1020070114105 11/2007
 KR 1020000059516 4/2012
 WO WO 96/25888 8/1996

(56) **References Cited**

FOREIGN PATENT DOCUMENTS

WO	WO9634568	11/1996
WO	WO 96/39079	12/1996
WO	WO 9735518	10/1997
WO	WO 9832379	7/1998
WO	WO 98/52465	11/1998
WO	WO 9933520	7/1999
WO	WO 9949788	10/1999
WO	WO 0006032	2/2000
WO	WO 0015300	3/2000
WO	WO 0021612	4/2000
WO	WO 0053113	9/2000
WO	WO 0128623	4/2001
WO	WO 0182777	11/2001
WO	WO 0182778	11/2001
WO	WO 0187161	11/2001
WO	WO0187161	11/2001
WO	WO 0209813	2/2002
WO	WO 0224050	3/2002
WO	WO02054018	7/2002
WO	WO 02092168	11/2002
WO	WO 03/053266	7/2003
WO	WO 03065347	8/2003
WO	WO 03070105	8/2003
WO	WO 03077833	9/2003
WO	WO 03086215	10/2003
WO	WO 03/096883	11/2003
WO	WO 03/099382	12/2003
WO	WO 03099177	12/2003
WO	WO 03101530	12/2003
WO	WO 2004000116	12/2003
WO	WO 2004080147	9/2004
WO	WO 2004110558	12/2004
WO	WO 2005011804	2/2005
WO	WO 2005065408	7/2005
WO	WO 2005090978	9/2005
WO	WO2005113068	12/2005
WO	WO 2006036870	4/2006
WO	WO 2006042163	4/2006
WO	WO 2006042168	4/2006
WO	WO 2006042201	4/2006
WO	WO 2006065671	6/2006
WO	WO 2006082573	8/2006
WO	WO 2007067563	6/2007
WO	WO 2008036622	3/2008
WO	WO2008036479	11/2008
WO	WO2008144274	11/2008
WO	WO 2009013729	1/2009
WO	WO2009149390	10/2009
WO	WO2012134645	1/2013
WO	WO2014045216	3/2014
WO	WO2014057388	4/2014

OTHER PUBLICATIONS

Alster, Tinas S., Tanzi, Elizabeth L., "Cellulite Treatment using a Novel Combination Radiofrequency, Infrared Light, and Mechanical Tissue Manipulation Device," *Journal of Cosmetic & Laser Therapy*, Jun. 2005, vol. 7, Issue 2, pp. 81-85.

Arthur et al., "Non-invasive estimation of hyperthermia temperatures with ultrasound," *Int. J. Hyperthermia*, Sep. 2005, 21(6), pp. 589-600.

Barthe et al., "Ultrasound therapy system and ablation results utilizing miniature imaging/therapy arrays," *Ultrasonics Symposium*, 2004 IEEE, Aug. 23, 2004, pp. 1792-1795, vol. 3.

Chen, L. et al., "Effect of Blood Perfusion on the ablation of liver parenchyma with high intensity focused ultrasound," *Phys. Med. Biol.*, 38:1661-1673; 1993b.

Coon, Joshua et al., "Protein identification using sequential ion/ion reactions and tandem mass spectrometry" *Proceedings of the National Academy of Sciences of the USA*, vol. 102, No. 27, Jul. 27, 2005, pp. 9463-9468.

Corry, Peter M., et al., "Human Cancer Treatment with Ultrasound", *IEEE Transactions on Sonics and Ultrasonics*, vol. SU-31, No. 5, Sep. 1984, pp. 444, 456.

Damianou et al., "Application of the Thermal Dose Concept for Predicting the Necrosed Tissue Volume During Ultrasound Surgery," 1993 IEEE Ultrasound Symposium, pp. 1199-1202.

Daum et al., Design and Evaluation of a Feedback Based Phased Array System for Ultrasound Surgery, *IEEE Transactions on Ultrasonics, Ferroelectrics, and Frequency Control*, vol. 45, No. 2, Mar. 1998, pp. 431-438.

Davis, Brian J., et al., "An Acoustic Phase Shift Technique for the Non-Invasive Measurement of Temperature Changes in Tissues", 1985 Ultrasonics Symposium, pp. 921-924.

Decision of the Korean Intellectual Property Tribunal dated Jun. 28, 2013 regarding Korean Patent No. 10-1142108, which is related to the pending application and/or an application identified in the Table on pp. 1-4 of the Information Disclosure Statement herein (English translation, English translation certification, and Korean decision included).

Fry, W.J. et al., "Production of Focal Destructive Lesions in the Central Nervous System with Ultrasound," *J. Neurosurg.*, 11:471-478; 1954.

Gliklich et al., Clinical Pilot Study of Intense Ultrasound therapy to Deep Dermal Facial Skin and Subcutaneous Tissues, *Arch Facial Plastic Surgery*, Mar. 1, 2007, vol. 9, No. 1.

Haar, G.R. et al., "Tissue Destruction with Focused Ultrasound in Vivo," *Eur. Urol.* 23 (suppl. 1):8-11; 1993.

Hassan et al., "Structure and Applications of Poly(vinyl alcohol) Hydrogels Produced by Conventional Crosslinking or by Freezing/Thawing Methods," *advanced in Polymer Science*, 2000, pp. 37-65, vol. 153.

Hassan et al., "Structure and Morphology of Freeze/Thawed PVA Hydrogels," *Macromolecules*, Mar. 11, 2000, pp. 2472-2479, vol. 33, No. 7.

Husseini et al., "The Role of Cavitation in Acoustically Activated Drug Delivery," *J. Control Release*, Oct. 3, 2005, pp. 253-261, vol. 107(2).

Husseini et al. "Investigating the mechanism of acoustically activated uptake of drugs from Pluronic micelles," *BMD Cancer* 2002, 2:20k, Aug. 30, 2002, pp. 1-6.

Jeffers et al., "Evaluation of the Effect of Cavitation Activity on Drug-Ultrasound Synergisms," 1993 IEEE Ultrasonics Symposium, pp. 925-928.

Jenne, J., et al., "Temperature Mapping for High Energy US-Therapy", 1994 Ultrasonics Symposium, pp. 1879-1882.

Johnson, S.A., et al., "Non-Intrusive Measurement of Microwave and Ultrasound-Induced Hyperthermia by Acoustic Temperature Tomography", *Ultrasonics Symposium Proceedings*, pp. 977-982. (1977).

Madersbacher, S. et al., "Tissue Ablation in Benign Prostatic Hyperplasia with High Intensity Focused Ultrasound," *Dur. Urol.*, 23 (suppl. 1):39-43; 1993.

Makin et al., "B-Scan Imaging and Thermal Lesion Monitoring Using Miniaturized Dual-Functionality Ultrasound Arrays," *Ultrasonics Symposium*, 2004 IEEE, Aug. 23, 2004, pp. 1788-1791, vol. 3.

Makin et al., "Confirmed Bulk Ablation and Therapy Monitoring Using Intracorporeal Image-Treat Ultrasound Arrays," 4th International Symposium on Therapeutic Ultrasound, Sep. 19, 2004.

Makin et al., "Miniaturized Ultrasound Arrays for Interstitial Ablation and Imaging," *UltraSound Med. Biol.* 2005, Nov. 1, 2005, pp. 1539-1550, vol. 31(11).

Manohar et al., "Photoacoustic mammography laboratory prototype: imaging of breast tissue phantoms," *Journal of Biomedical Optics*, Nov./Dec. 2004, pp. 1172-1181, vol. 9, No. 6.

Mast et al., "Bulk Ablation of Soft Tissue with Intense Ultrasound; Modeling and Experiments," *J. Acoust. Soc. Am.*, Oct. 1, 2005, pp. 2715-2724, vol. 118(4).

Mitragotri, S., "Healing sound: the use of ultrasound in drug delivery and other therapeutic applications," *Nature Reviews; Drug Delivery*, pp. 255-260, vol. 4 (Mar. 2005).

Paradossi et al., "Poly(vinyl alcohol) as versatile biomaterial for potential biomedical applications," *Journal of Materials Science: Materials in Medicine*, 2003, pp. 687-691, vol. 14.

Reid, Gavin, et al., "Tandem Mass spectrometry of ribonuclease A and B: N-linked glycosylation site analysis of whole protein ions," *Analytical Chemistry*. Feb. 1, 2002, vol. 74, No. 3, pp. 577-583.

(56)

References Cited

OTHER PUBLICATIONS

- Righetti et al., "Elastographic Characterization of HIFU-Induced Lesions in Canine Livers," 1999, *Ultrasound in Med & Bio*, vol. 25, No. 7, pp. 1099-1113.
- Saad et al., "Ultrasound-Enhanced Effects of Adriamycin Against Murine Tumors," *Ultrasound in Med. & Biol.* vol. 18, No. 8, pp. 715-723 (1992).
- Sanghvi, N.T., et al., "Transrectal Ablation of Prostrate Tissue Using Focused Ultrasound," 1993 *Ultrasonics Symposium*, IEEE, pp. 1207-1210.
- Sassen, Sander, "ATI's R520 architecture, the new king of the hill?" <http://www.hardwareanalysis.com/content/article/1813>, Sep. 16, 2005, 2 pages.
- Seip, Ralf, et al., "Noninvasive Detection of Thermal Effects Due to Highly Focused Ultrasonic Fields," *IEEE Symposium*, pp. 1229-1232, vol. 2, Oct. 3-Nov. 1993.
- Seip, Ralf, et al., "Noninvasive Estimation of Tissue Temperature Response to Heating Fields Using Diagnostic Ultrasound," *IEEE Transactions on Biomedical Engineering*, vol. 42, No. 8, Aug. 1995, pp. 828-839.
- Simon et al., "Applications of Lipid-Coated Microbubble Ultrasonic Contrast to Tumor Therapy," *Ultrasound in Med. & Biol.* vol. 19, No. 2, pp. 123-125 (1993).
- Smith, Nadine Barrie, et al., "Non-invasive In Vivo Temperature Mapping of Ultrasound Heating Using Magnetic Resonance Techniques", 1994 *Ultrasonics Symposium*, pp. 1829-1832, vol. 3.
- Surry et al., "Poly(vinyl alcohol) cryogel phantoms for use in ultrasound and MR imaging," *Phys. Med. Biol.*, Dec. 6, 2004, pp. 5529-5546, vol. 49.
- Syka J. E. P. et al., "Peptide and Protein Sequence Analysis by Electron Transfer Dissociation Mass Spectrometry," *Proceedings of the National Academy of Sciences of USA*, National Academy of Science, Washington, DC, vol. 101, No. 26, Jun. 29, 2004, pp. 9528-9533.
- Talbert, D. G., "An Add-On Modification for Linear Array Real-Time Ultrasound Scanners to Produce 3D Displays," *UTS Int'l 1977 Brighton, England* (Jun. 28-30, 1977) pp. 57-67.
- Tata et al., "Interaction of Ultrasound and Model Membrane Systems: Analyses and Predictions," *American Chemical Society, Phys. Chem.* 1992, 96, pp. 3548-3555.
- Ueno, S., et al., "Ultrasound Thermometry in Hyperthermia", 1990 *Ultrasonic Symposium*, pp. 1645-1652.
- Wang, H., et al., "Limits on Focused Ultrasound for Deep Hyperthermia", 1994 *Ultrasonic Symposium*, Nov. 1-4, 1994, pp. 1869-1872, vol. 3.
- Wasson, Scott, "NVIDIA's GeForce 7800 GTX graphics processor Power MADD," <http://techreport.com/reviews/2005q2/geforce-7800gtx/index.x?pg=1>, Jun. 22, 2005, 4 pages.
- White et al "Selective Creating of Thermal Injury Zones in the Superficial Musculoaponeurotic System Using Intense Ultrasound Therapy," *Arch Facial Plastic Surgery*, Jan./Feb. 2007, vol. 9, No. 1.
- Agren, Magnus S. et al., Collagenase in Wound Healing: Effect of Wound Age and Type. *The Journal of Investigative Dermatology*, vol. 99/No. 6, (Dec. 1992).
- Bozec, Laurent et al., Thermal Denaturation Studies of Collagen by Microthermal Analysis and Atomic Force Microscopy, *Biophysical Journal*, vol. 101, pp. 228-236. (Jul. 2001).
- Dierickx, Christine C., "The Role of Deep Heating for Noninvasive Skin Rejuvenation" *Lasers in Surgery and Medicine* 38:799-807 (2006).
- Dong, Yuan-Lin et al., "Effect of Ibuprofen on the Inflammatory Response to Surgical Wounds" *The Journal of Trauma*, vol. 35, No. 3. (1993).
- Dvivedi, Sanjay, et al. "Effect of Ibuprofen and diclofenac sodium on experimental wound healing" *Indian Journal of Experimental Biology*, vol. 35, pp. 1243-1245. (Nov. 1997).
- Greenhalgh, David G., "Wound healing and diabetes mellitus" *Clinics in Plastic Surgery* 30; 37-45. (2003).
- Guo, S. al., S et al., "Factors Affecting Wound Healing" *Critical Reviews in Oral Biology & Medicine*, *J Dent Res* 89(3), pp. 219-229. (2010).
- Hantash, Basil M. et al., "Bipolar Fractional Radiofrequency Treatment Induces Neoenlastogenesis and Neocollagenesis" *Lasers in Surgery and Medicine* 41:1-9 (2009).
- Hantash, Basil M. et al., "In Vivo Histological Evaluation of a Novel Ablative Fractional Resurfacing Device" *Lasers in Surgery and Medicine* 39:96-107 (2007).
- Krischak, G.D., et al., "The effects of non-steroidal anti-inflammatory drug application on incisional wound healing in rats" *Journal of Wound Care*, vol. 6, No. 2, (Feb. 2007).
- Lin, Sung-Jan, et al., "Monitoring the thermally induced structural transitions of collagen by use of second-harmonic generation microscopy" *Optics Letters*, vol. 30, No. 6, (Mar. 15, 2005).
- Meshkinpour, Azin, et al., "Treatment of Hypertrophic Scars and Keloids With a Radiofrequency Device: A Study of Collagen Effects" *Lasers in Surgery and Medicine* 37:343-349 (2005).
- Mosser, David M. et al., "Exploring the full spectrum of macrophage activation" *Nat Rev Immunol*; 8(12): 958-969. (Dec. 2008).
- Murota, Sei-Itzu, et al., "Stimulatory Effect of Prostaglandins on the Production of Hexosamine-Containing Substances by Cultured Fibroblasts (3) Induction of Hyaluronic Acid Synthetase by Prostaglandin" Department of Pharmacology, Tokyo Metropolitan Institute of Gerontology, Itabashiku, Tokyo-173, Japan. (Nov. 1977, vol. 14, No. 5).
- Murota, Sei-Itzu, et al., "The Stimulatory Effect of Prostaglandins on Production of Hexosamine-Containing Substances by Cultured Fibroblasts" Department of Pharmacology, Tokyo Metropolitan Institute of Gerontology, Itabashiku, Tokyo-173, Japan. (Aug. 1976, vol. 12, No. 2).
- Rappolee, Daniel A., et al., "Wound Macrophages Express TGF and Other Growth Factors in Vivo: Analysis by mRNA Phenotyping" *Science*, vol. 241, No. 4866 (Aug. 1988).
- Rosenberg, Carol S. "Wound Healing in the Patient with Diabetes Mellitus" *Nursing Clinics of North America*, vol. 25, No. 1, (Mar. 1990).
- Sandulache, Vlad C. et al., "Prostaglandin E2 inhibition of keloid fibroblast migration, contraction, and transforming growth factor (TGF)-B1-induced collagen synthesis" *Wound Rep Reg* 15 122-133, 2007.
- Suh, Dong Hye et al., "Intense Focused Ultrasound Tightening in Asian Skin: Clinical and Pathologic Results" *American Society for Dermatologic Surgery, Inc.*; 37:1595-1602. (2011).
- Verhofstad, Michiel H.J. et al., "Collagen Synthesis in rat skin and ileum fibroblasts is affected differently by diabetes-related factors" *Int. J. Exp. Path.* (1998), 79, 321-328.
- White, W. Matthew, et al., "Selective Transcutaneous Delivery of Energy to Porcine Soft Tissues Using Intense Ultrasound (IUS)" *Lasers in Surgery and Medicine* 40:67-75 (2008).
- Zelickson, Brian D. et al., "Histological and Ultrastructural Evaluation of the Effects of a Radiofrequency-Based Nonablative Dermal Remodeling Device, A Pilot Study" *Arch Dermatol*, vol. 140, (Feb. 2004).

* cited by examiner

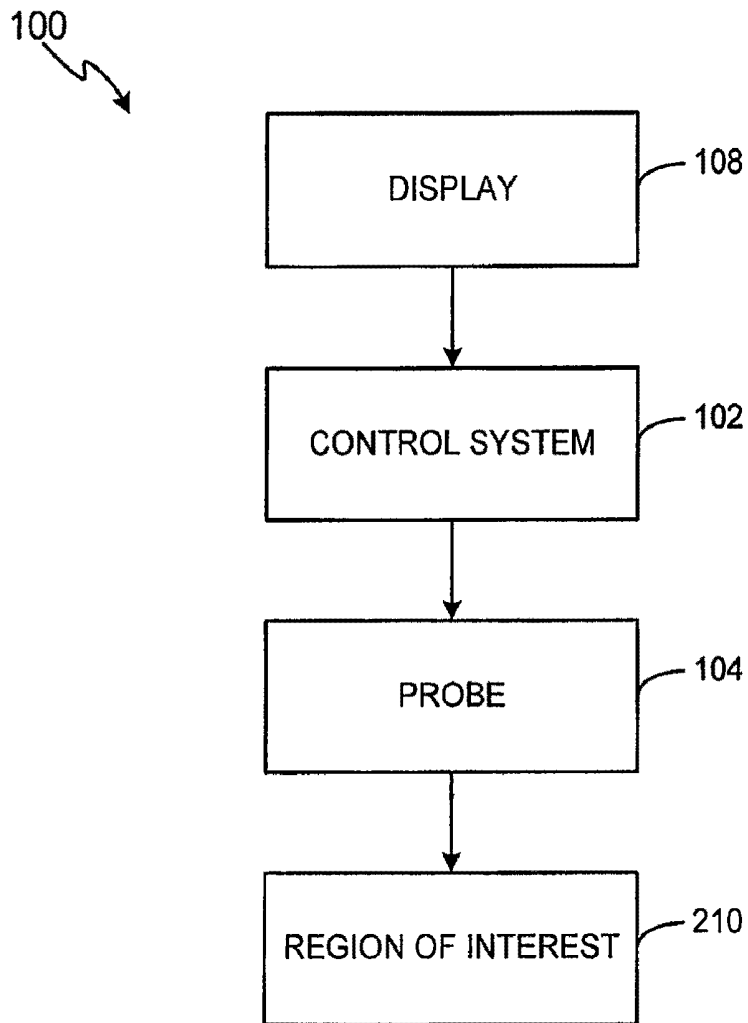

FIG. 1

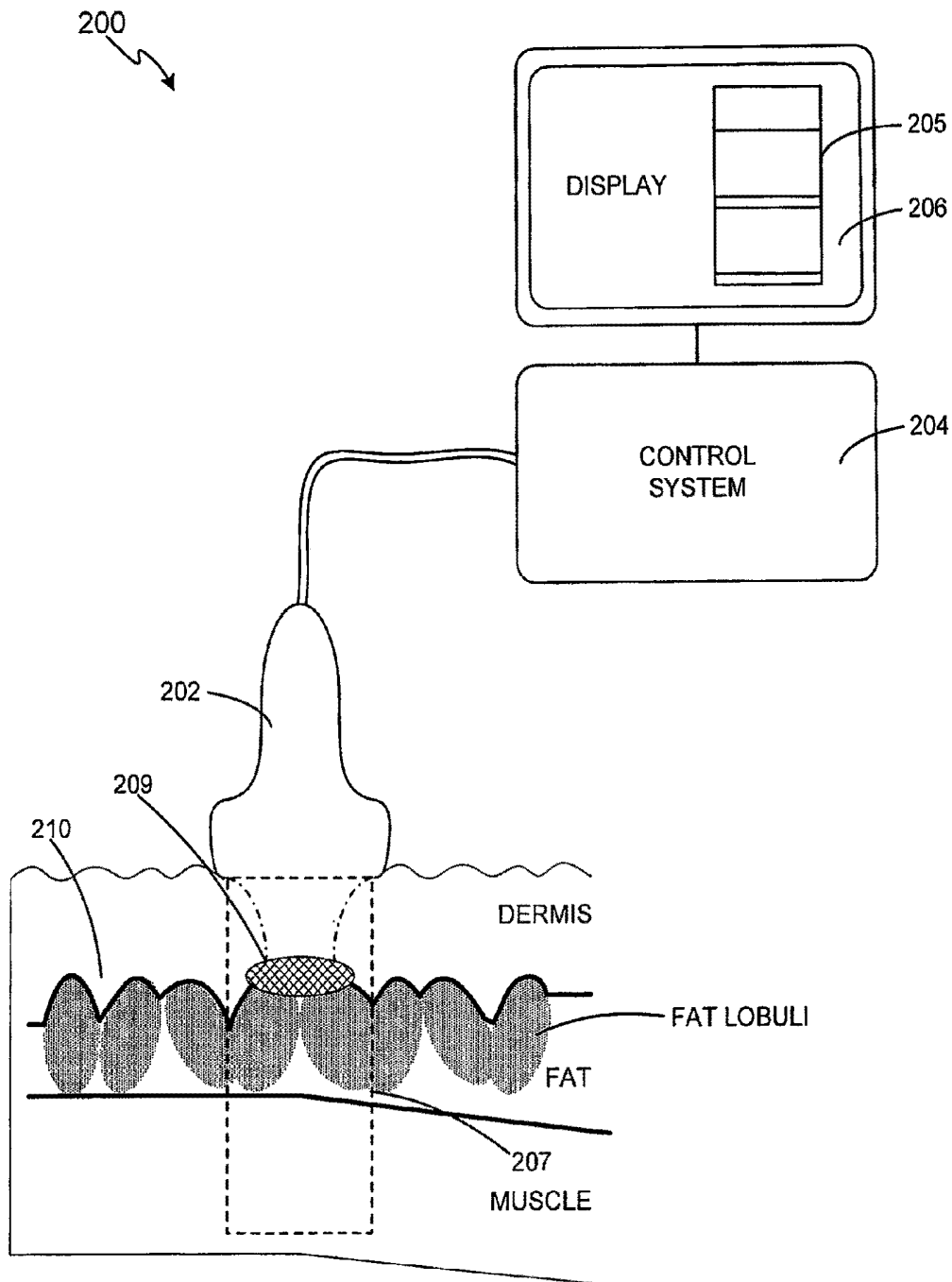

FIG. 2

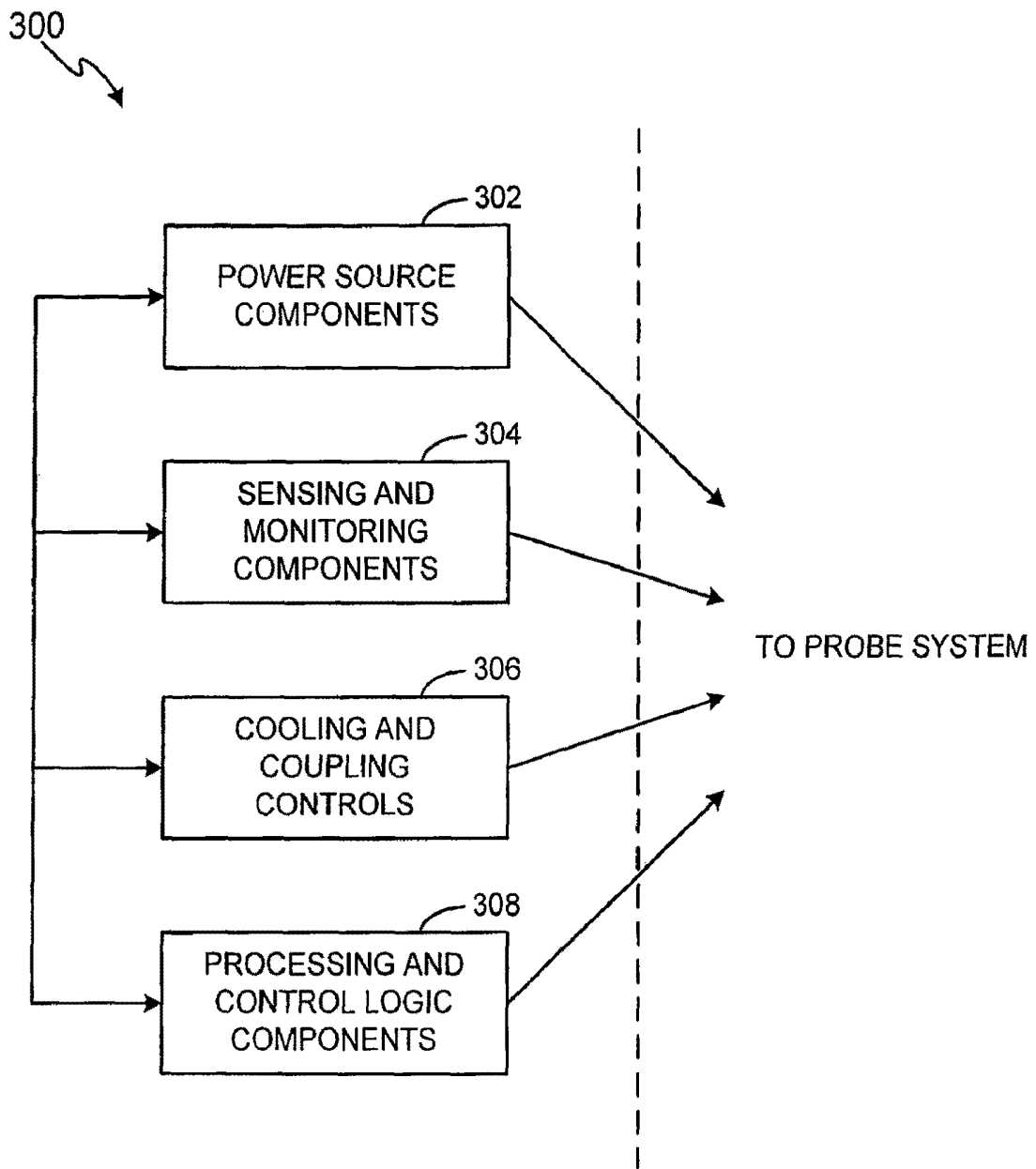

FIG. 3A

300 ↘

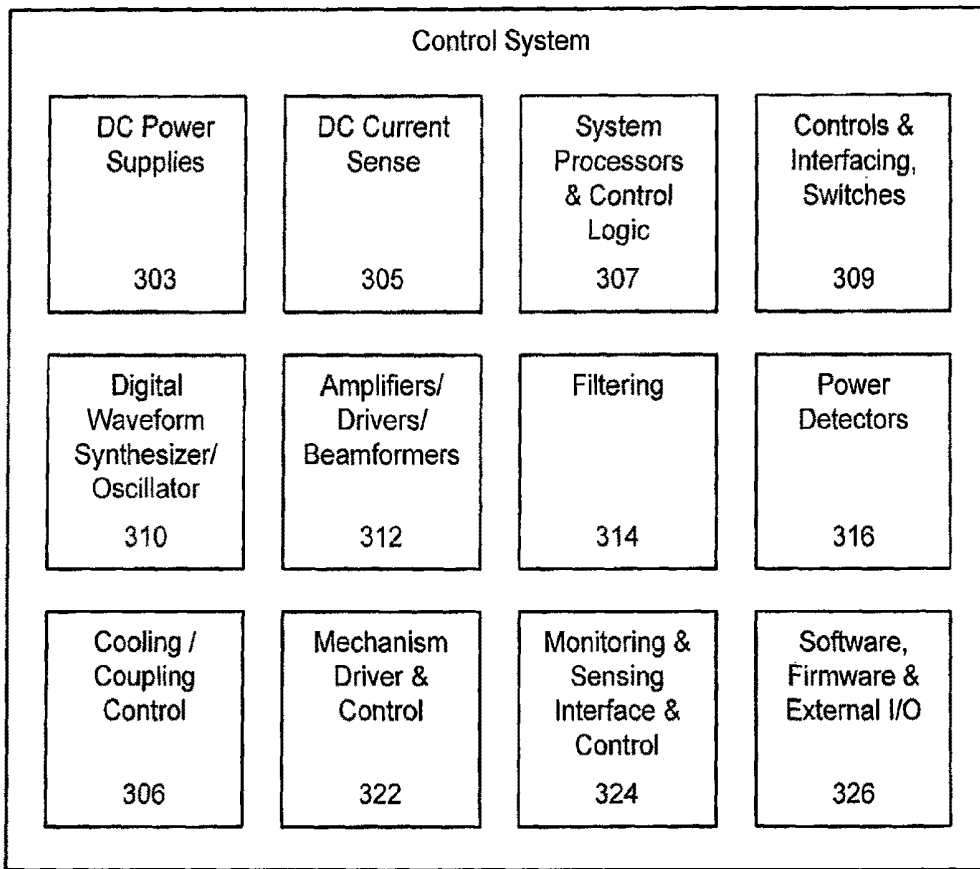

FIG. 3B

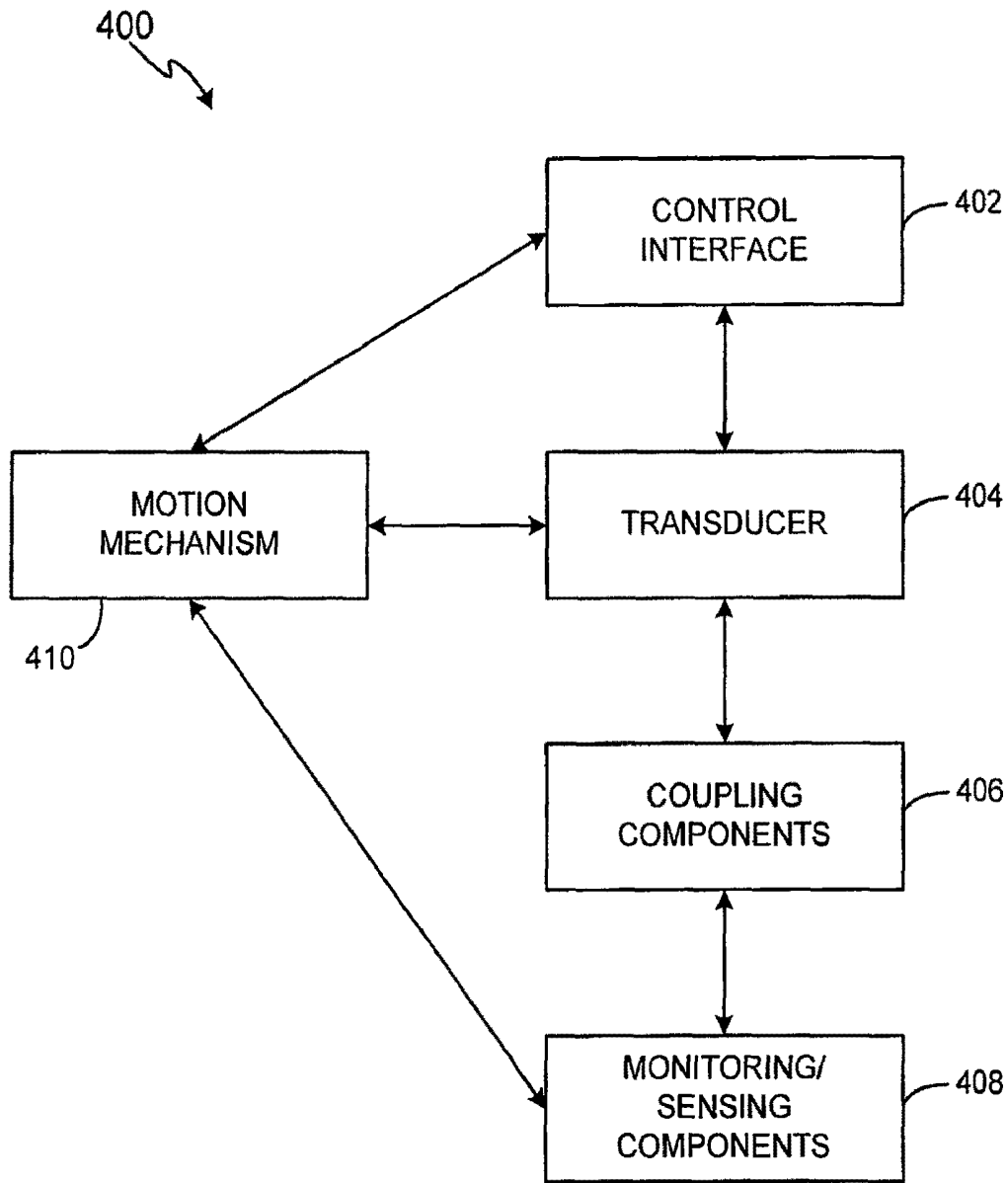

FIG. 4A

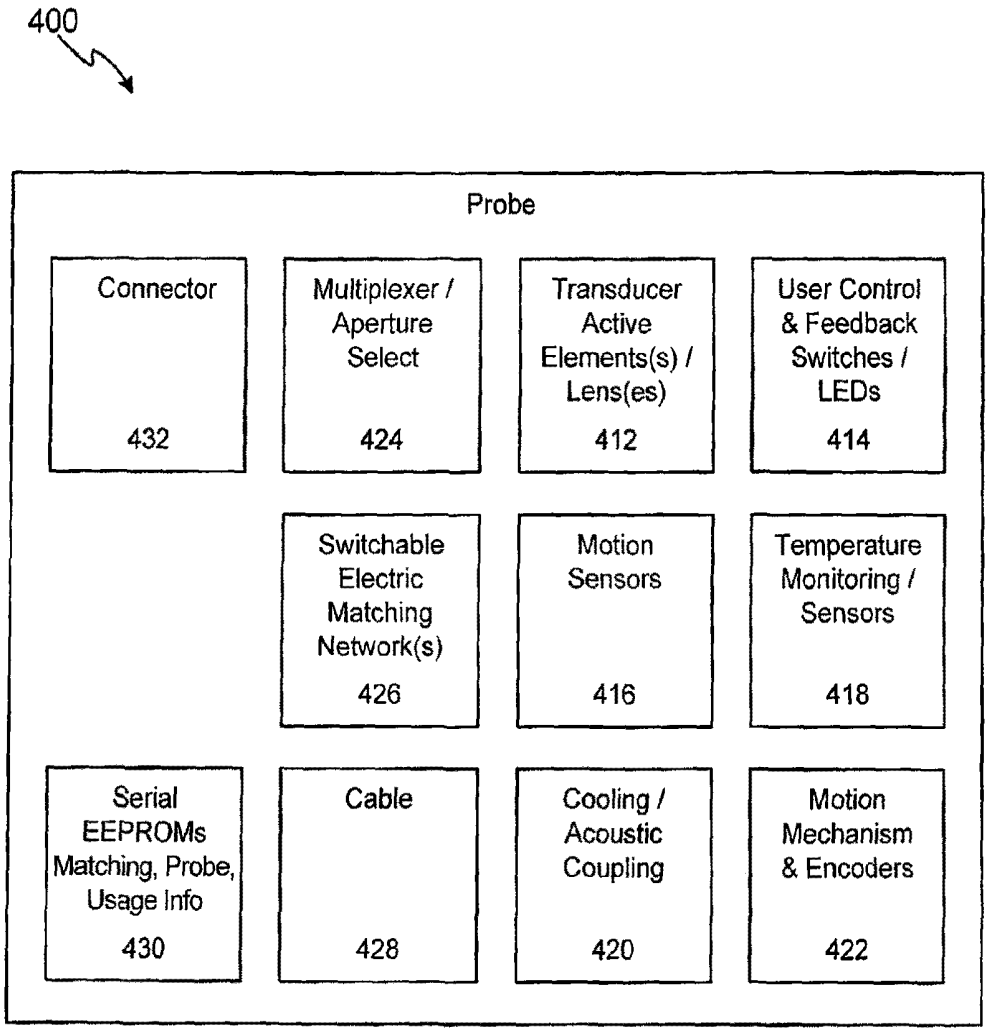

FIG. 4B

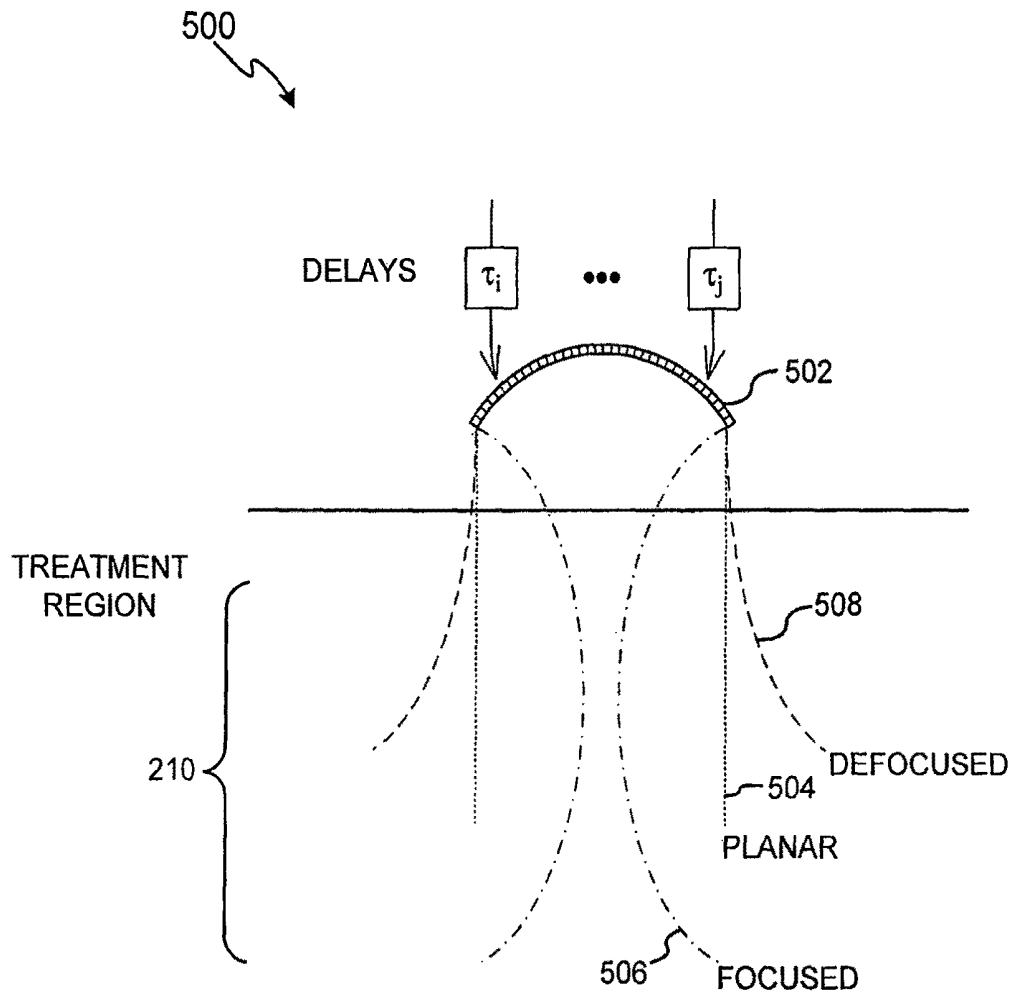

FIG. 5

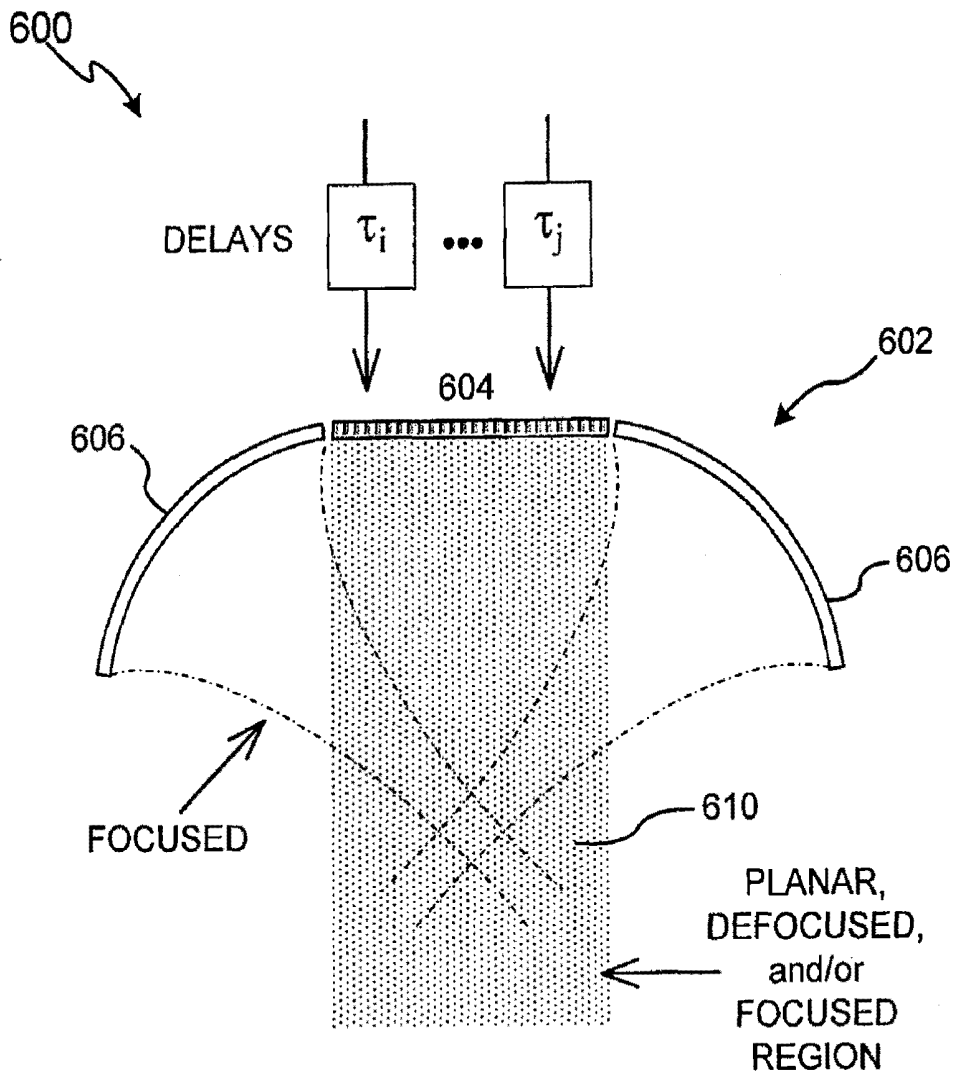

FIG. 6A

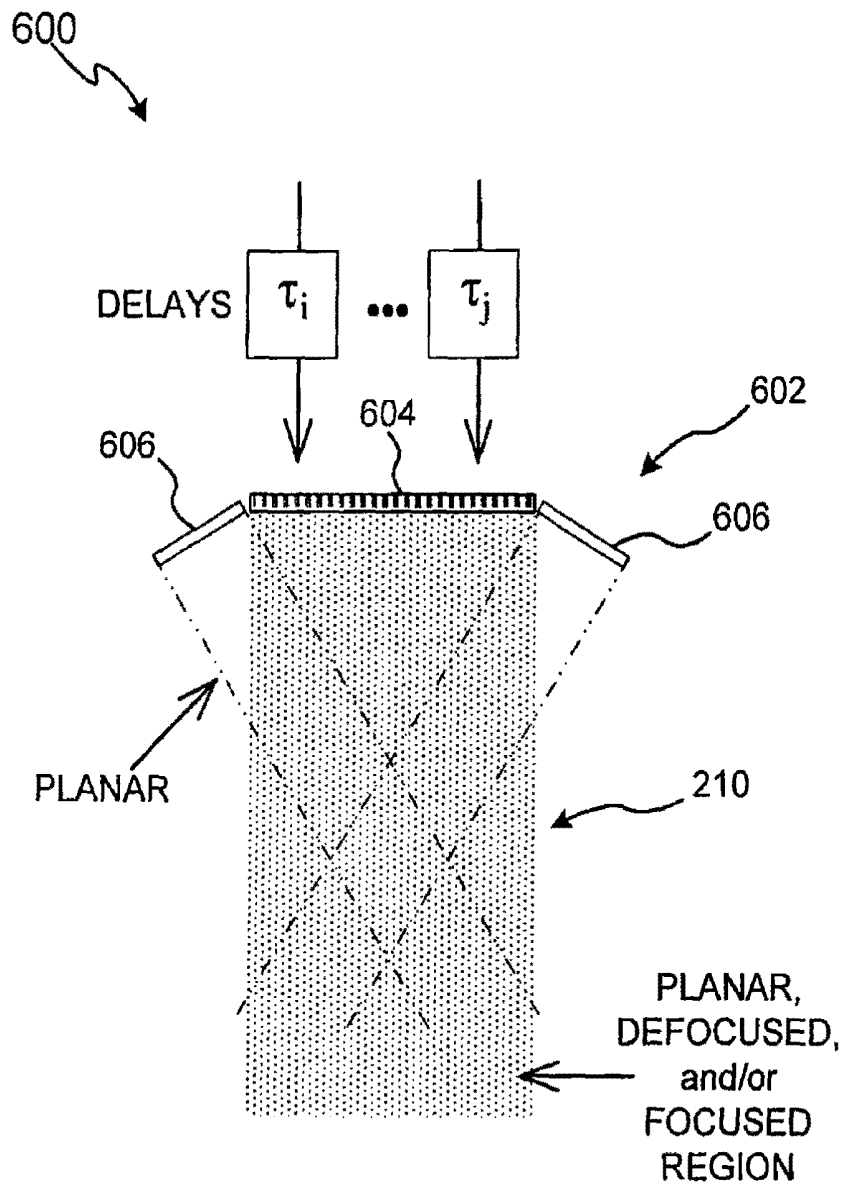

FIG. 6B

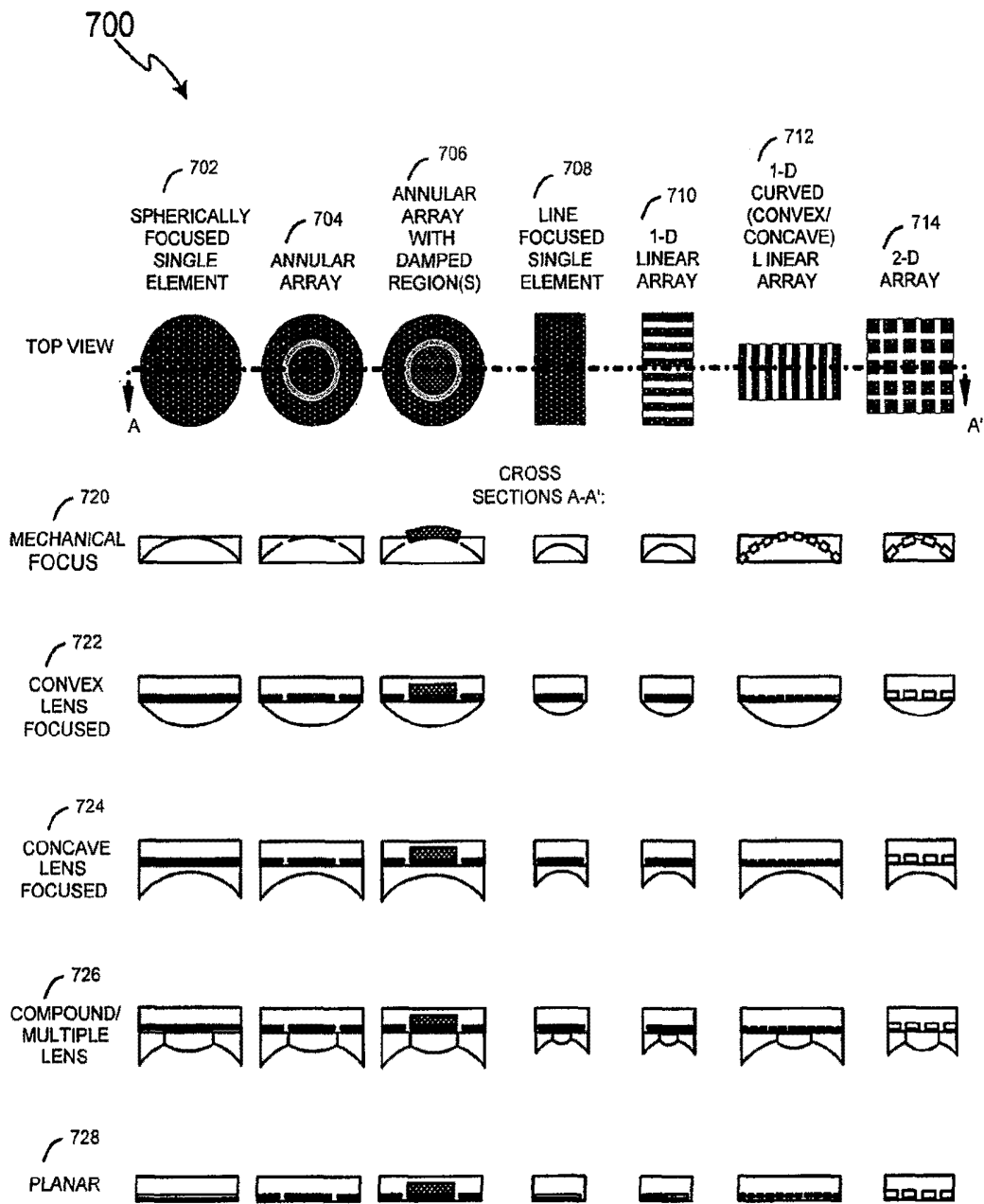

FIG. 7

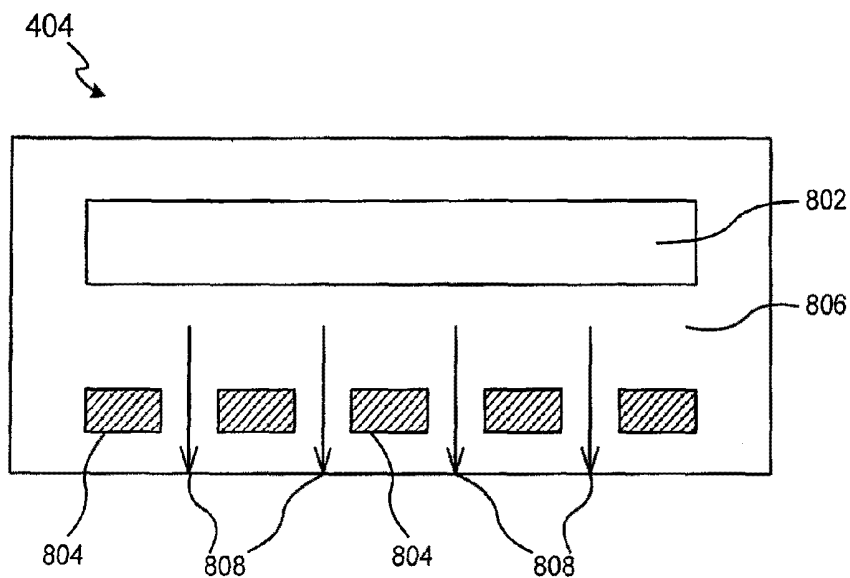

FIG. 8A

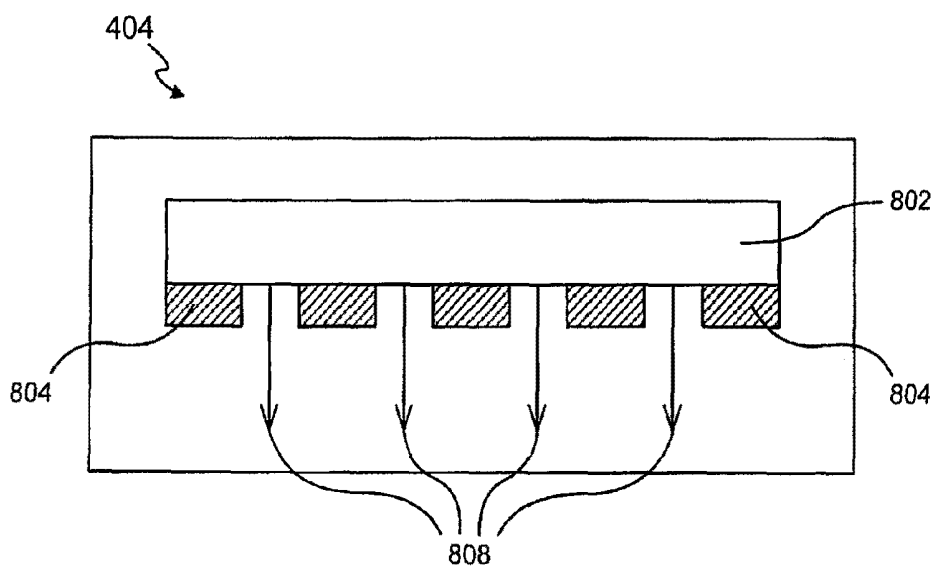

FIG. 8B

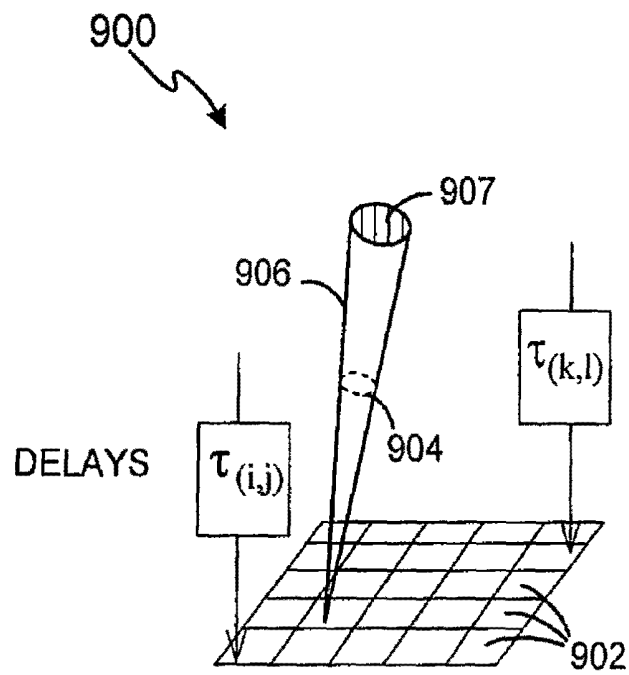

FIG. 9

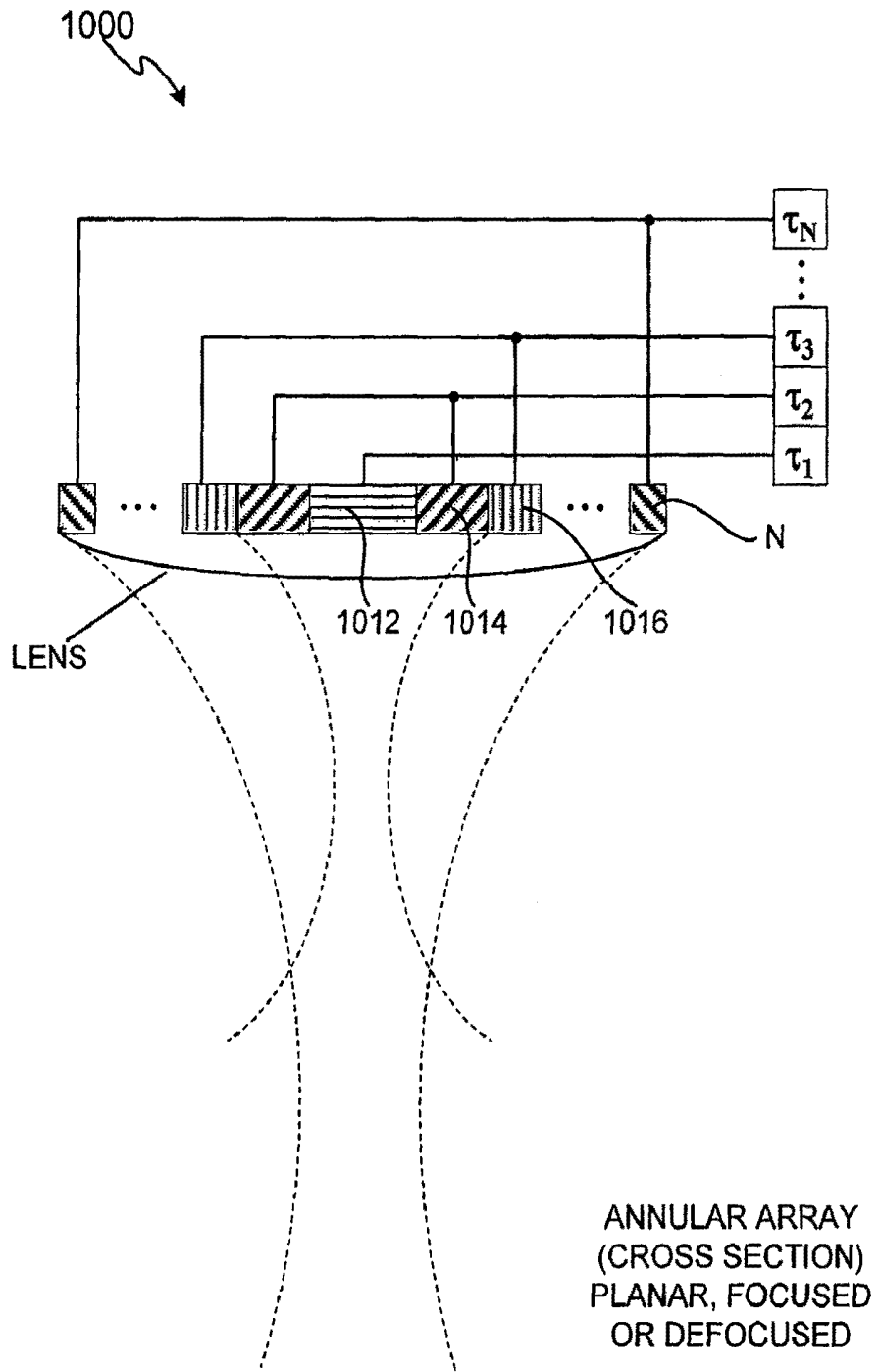

FIG. 10A

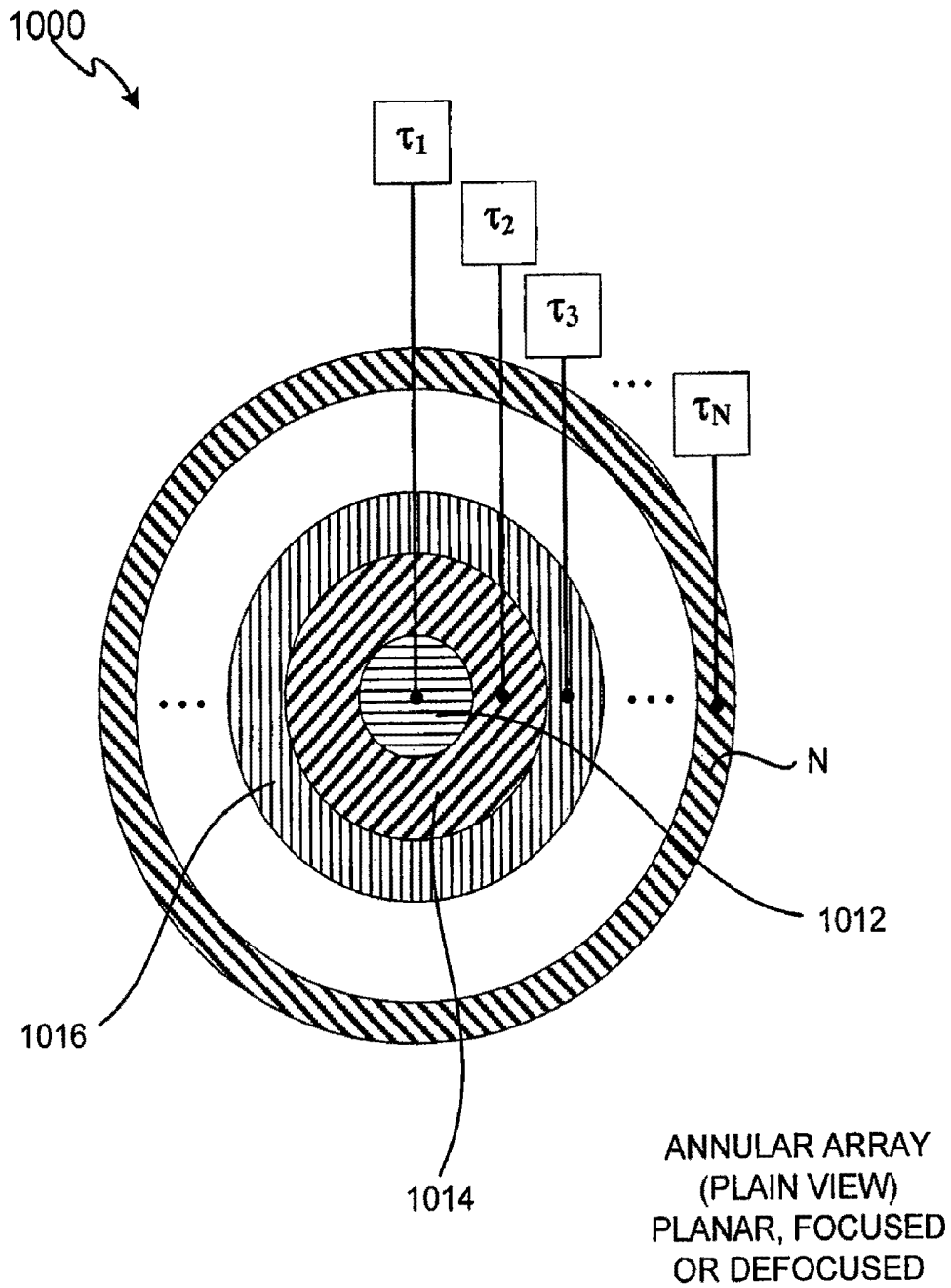

FIG. 10B

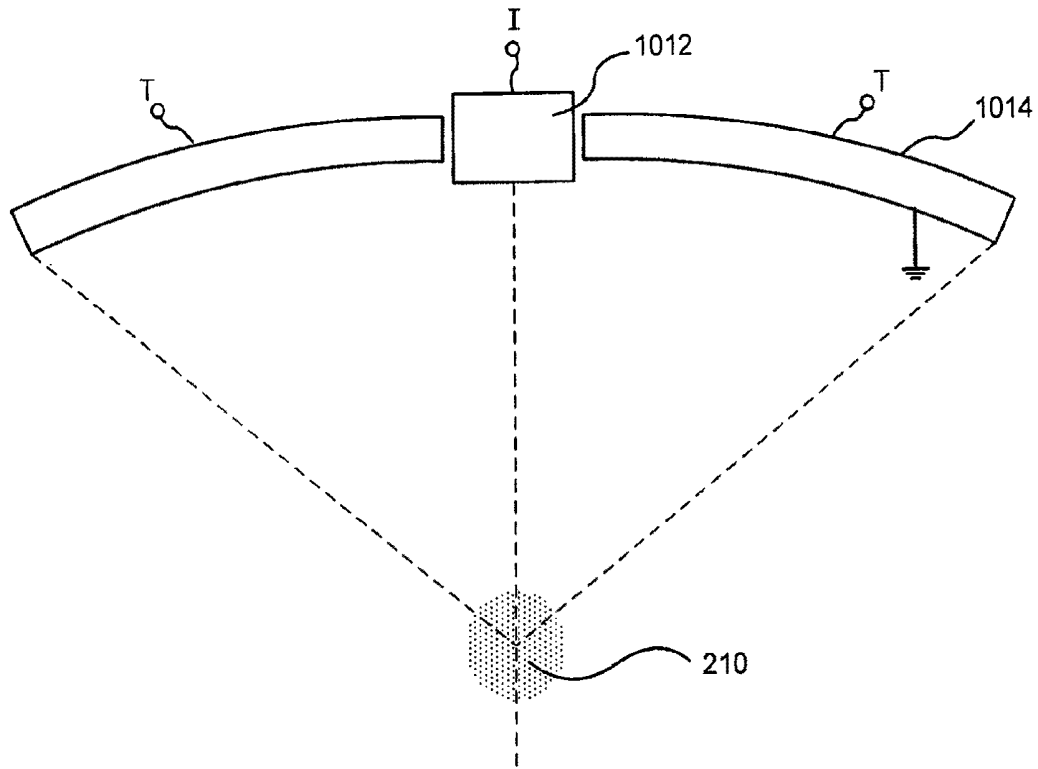

FIG. 10C

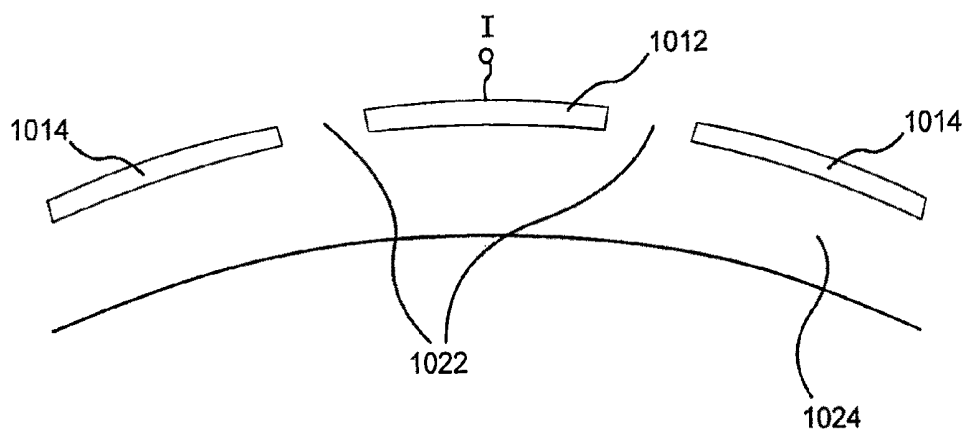

FIG. 10D

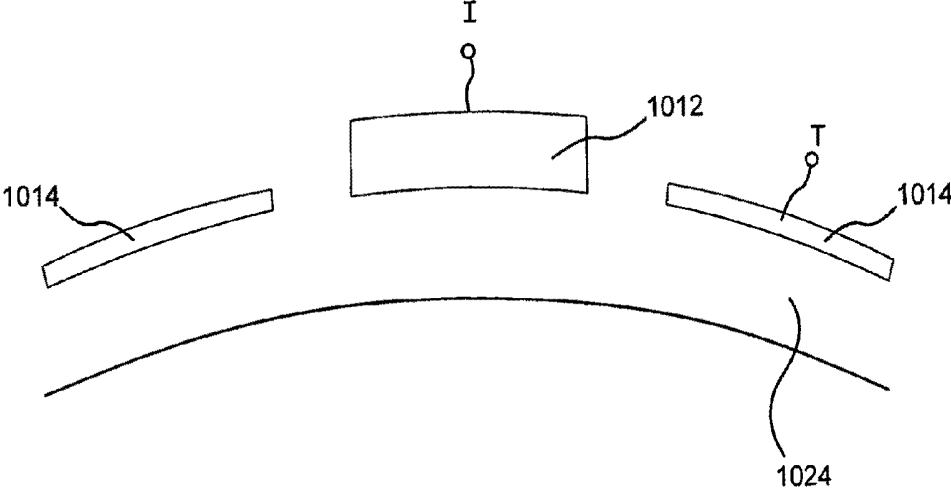

FIG. 10E

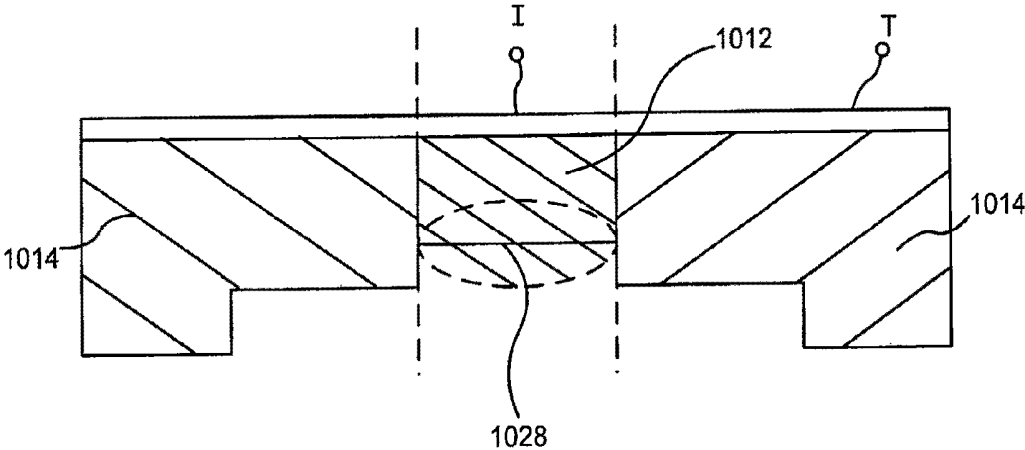

FIG. 10F

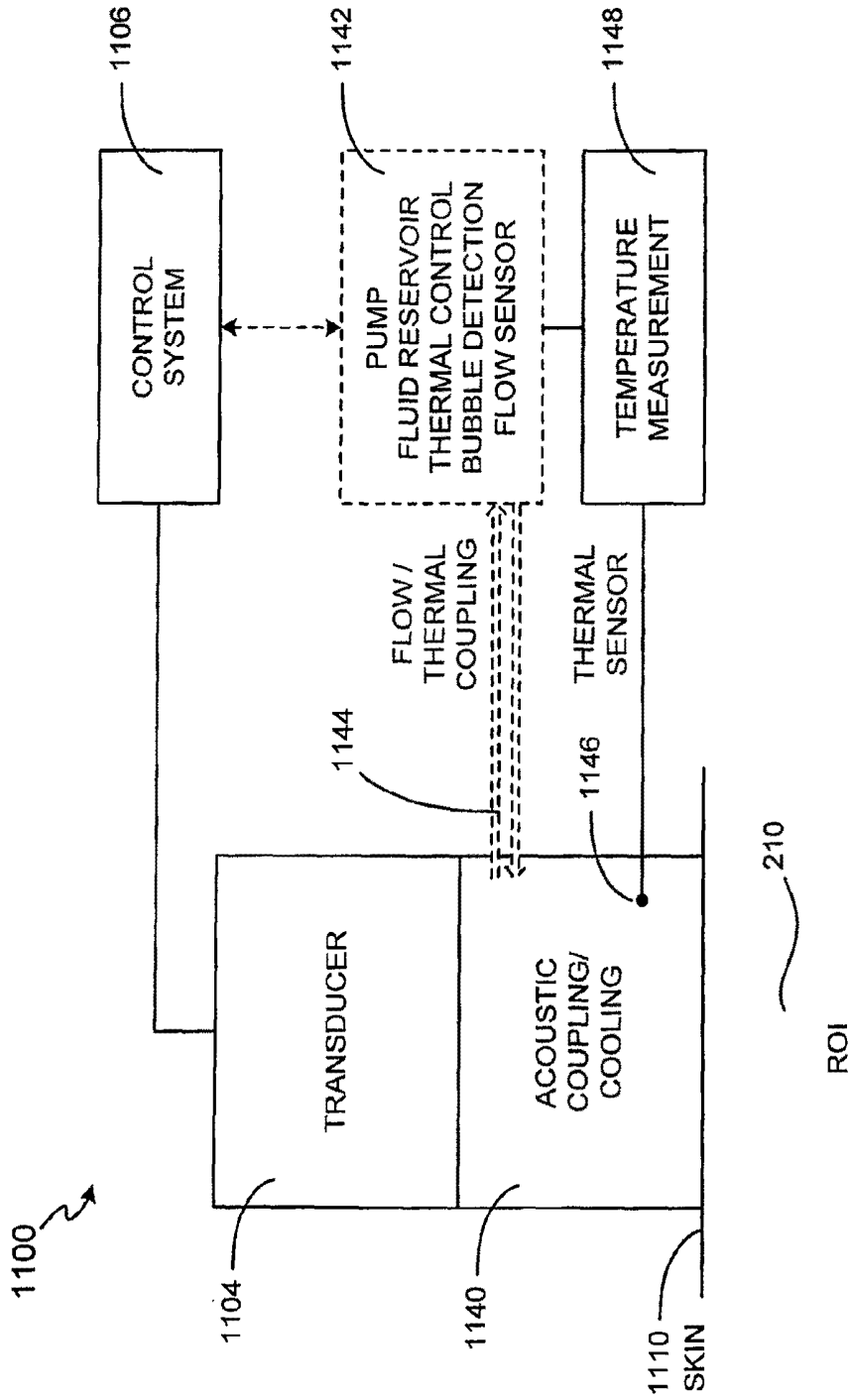

FIG. 11

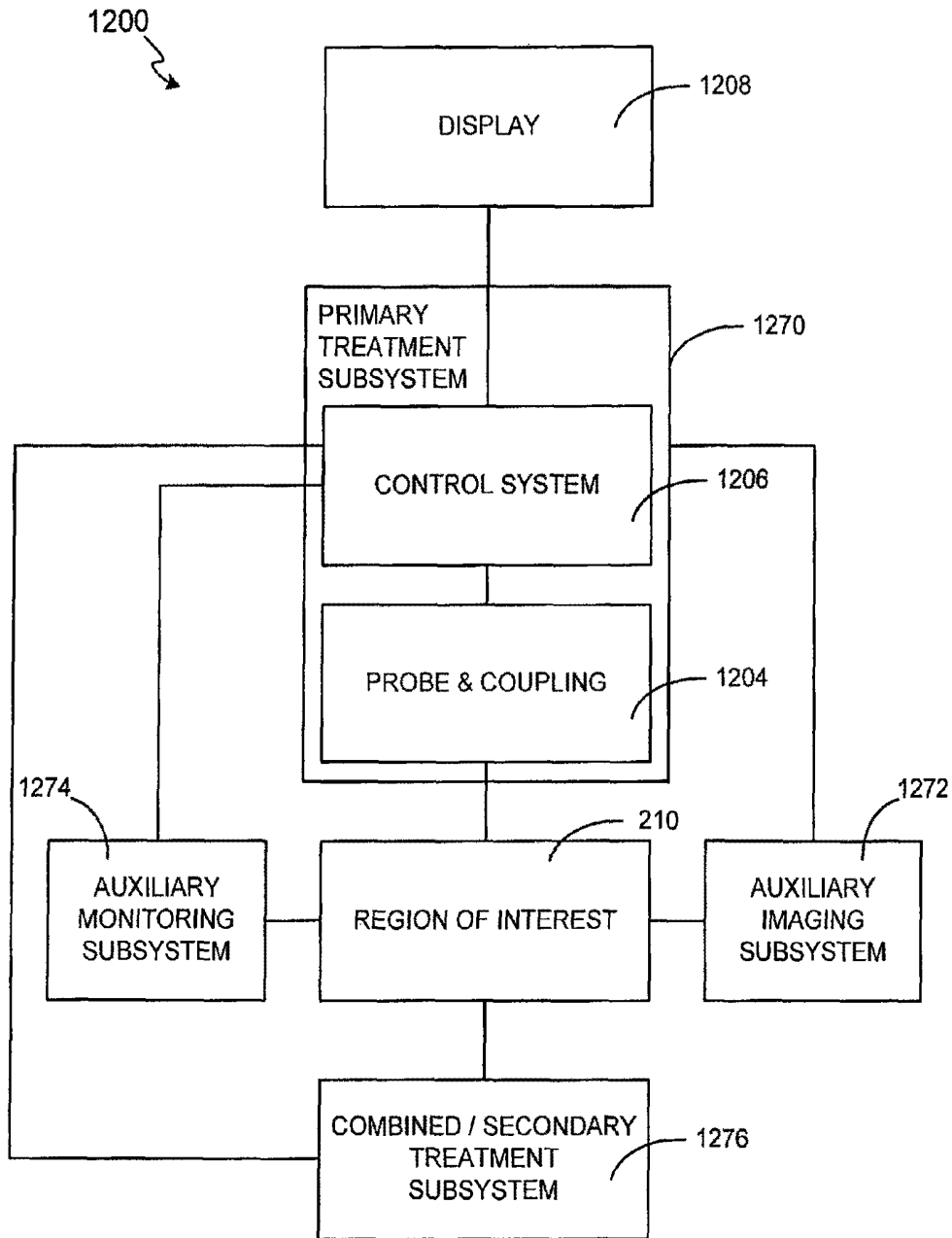

FIG. 12

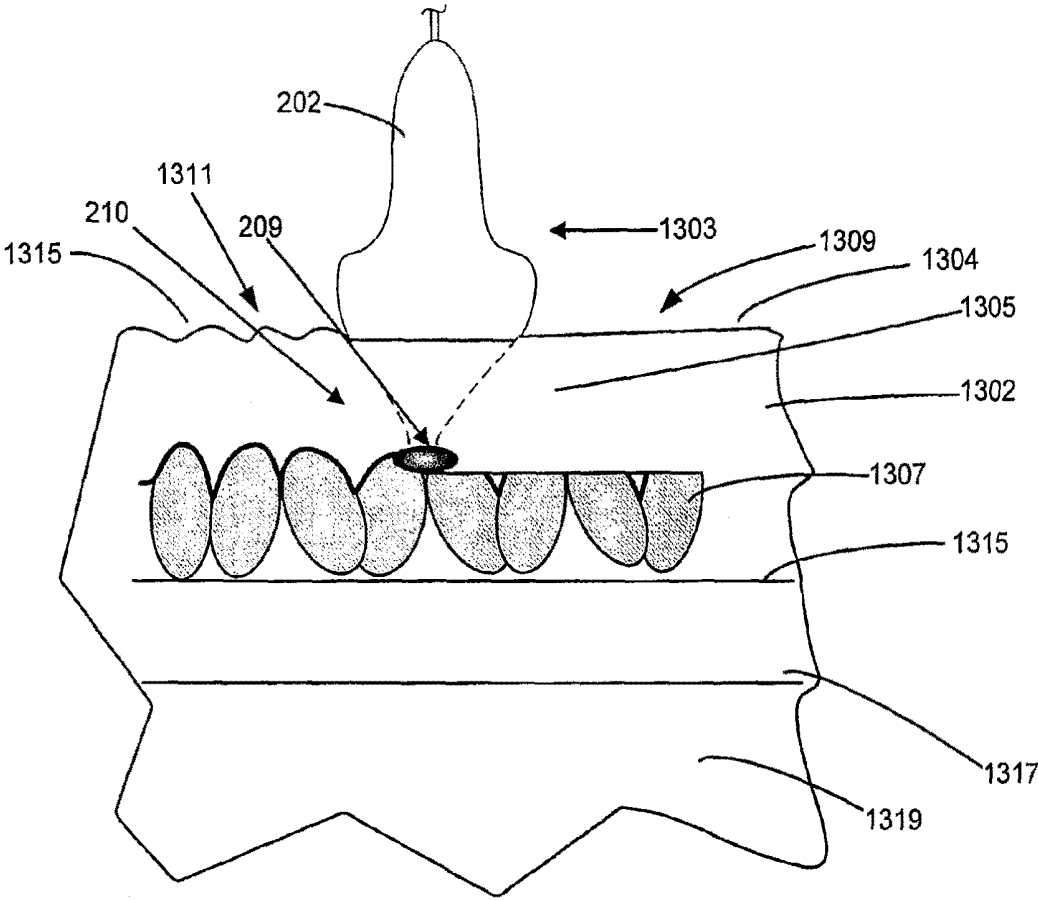

FIG. 13

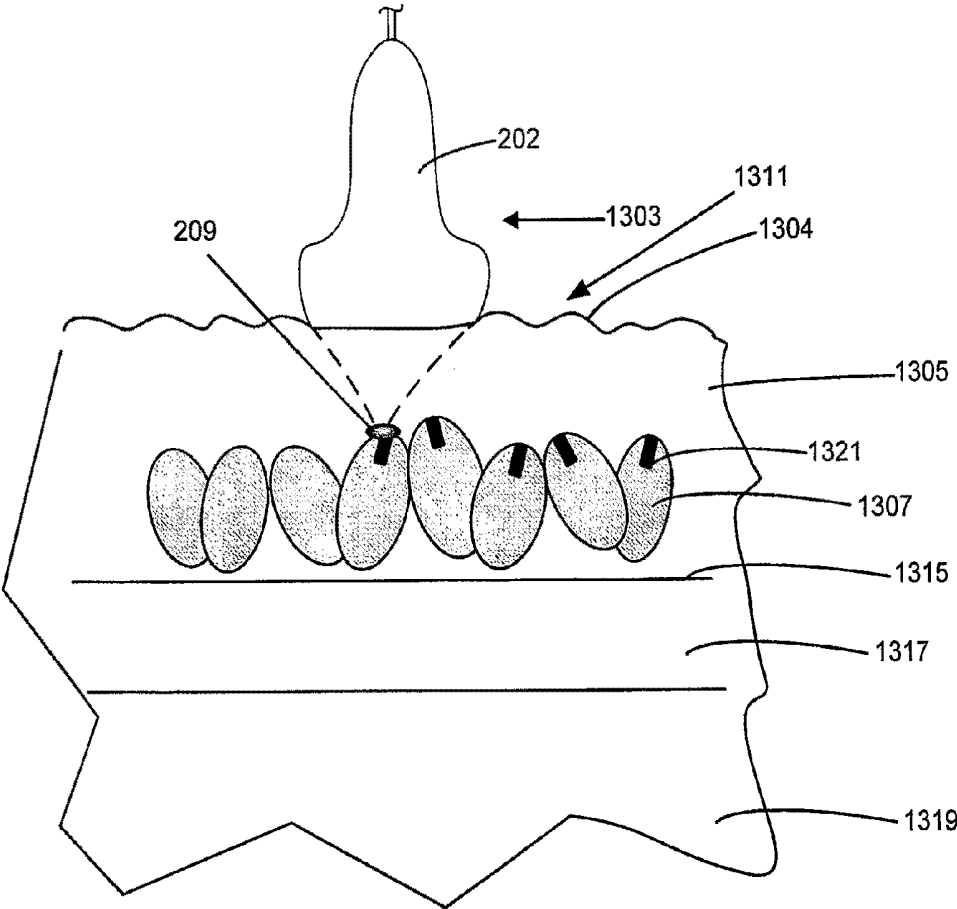

FIG. 14A

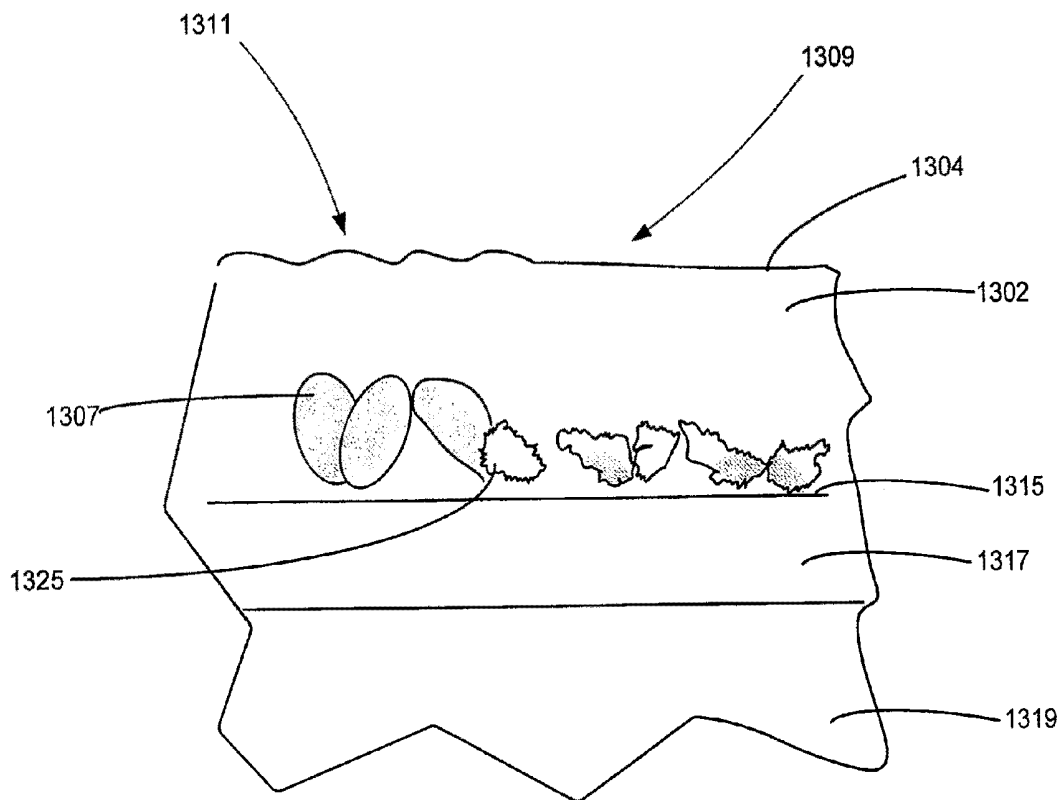

FIG. 14B

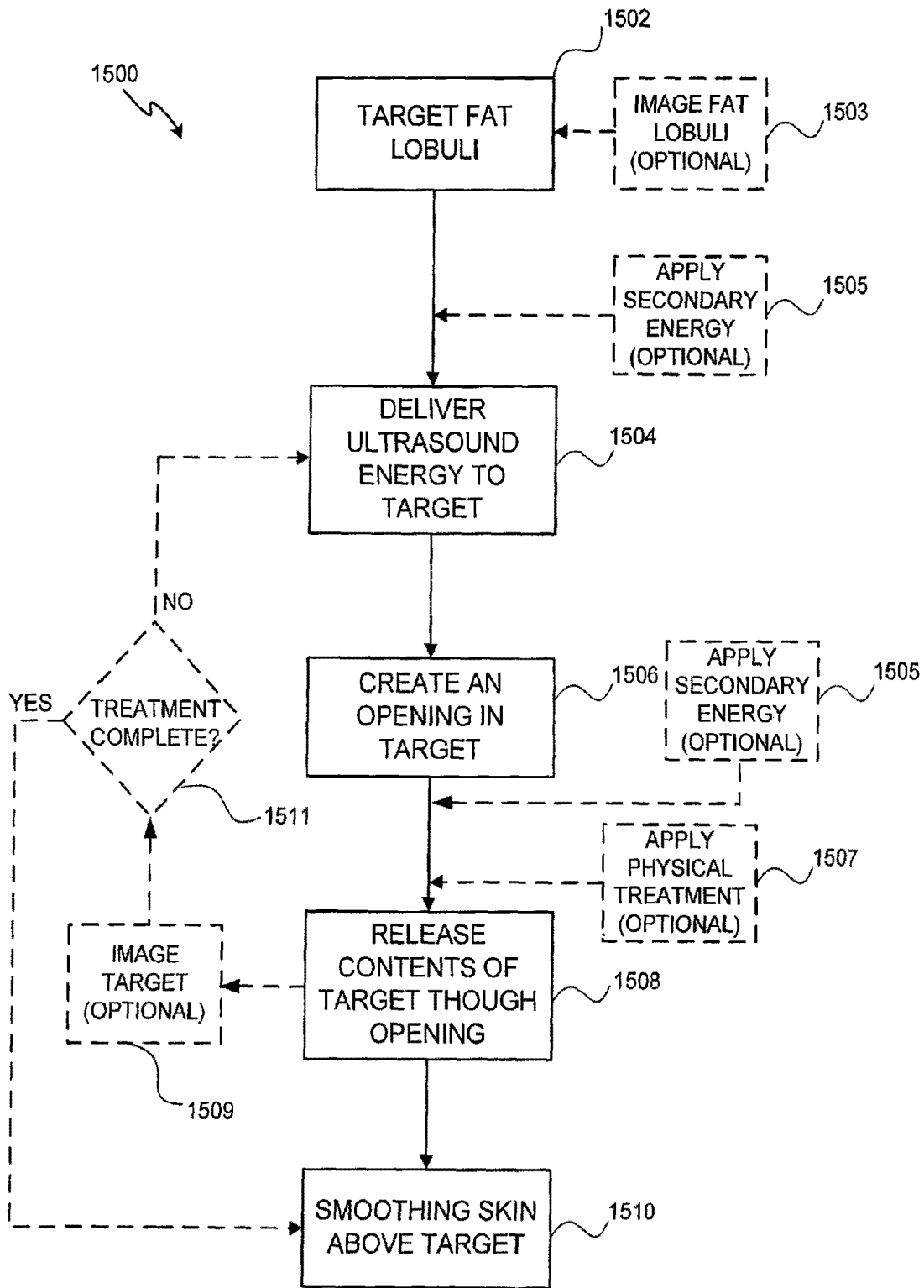

FIG. 15

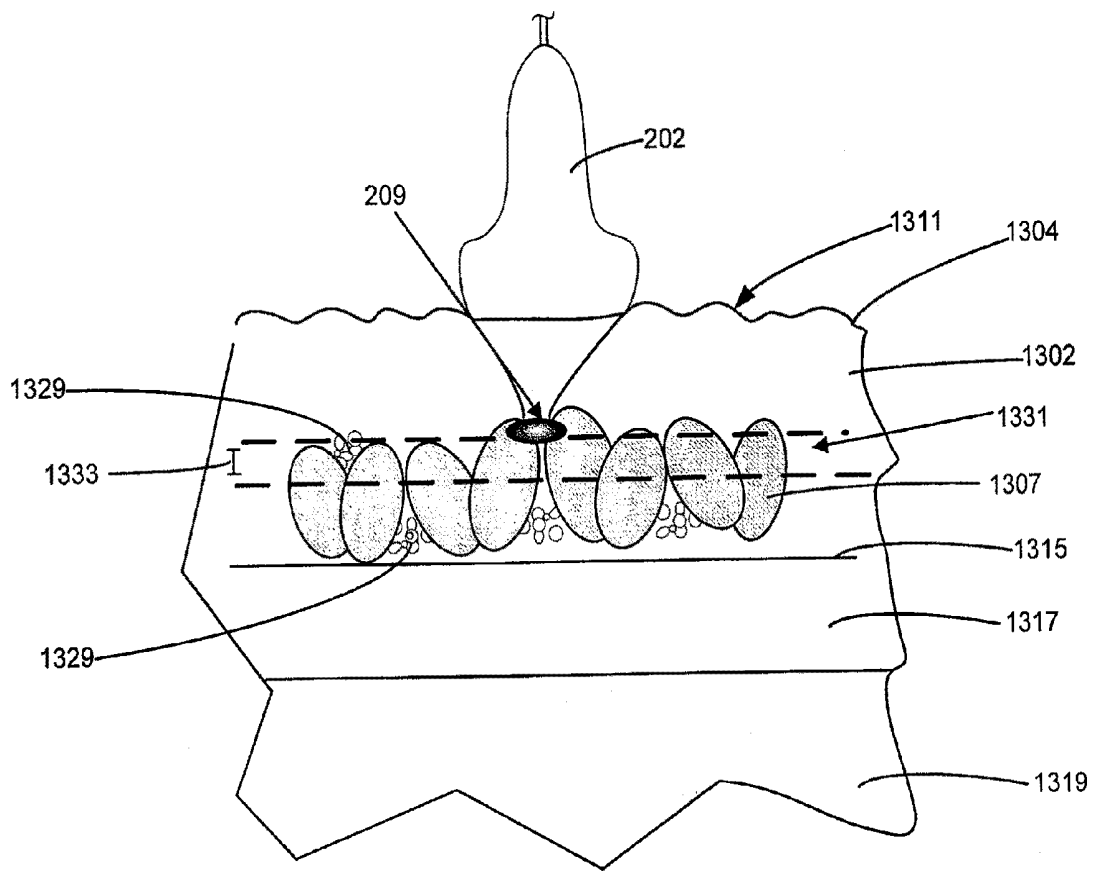

FIG. 16A

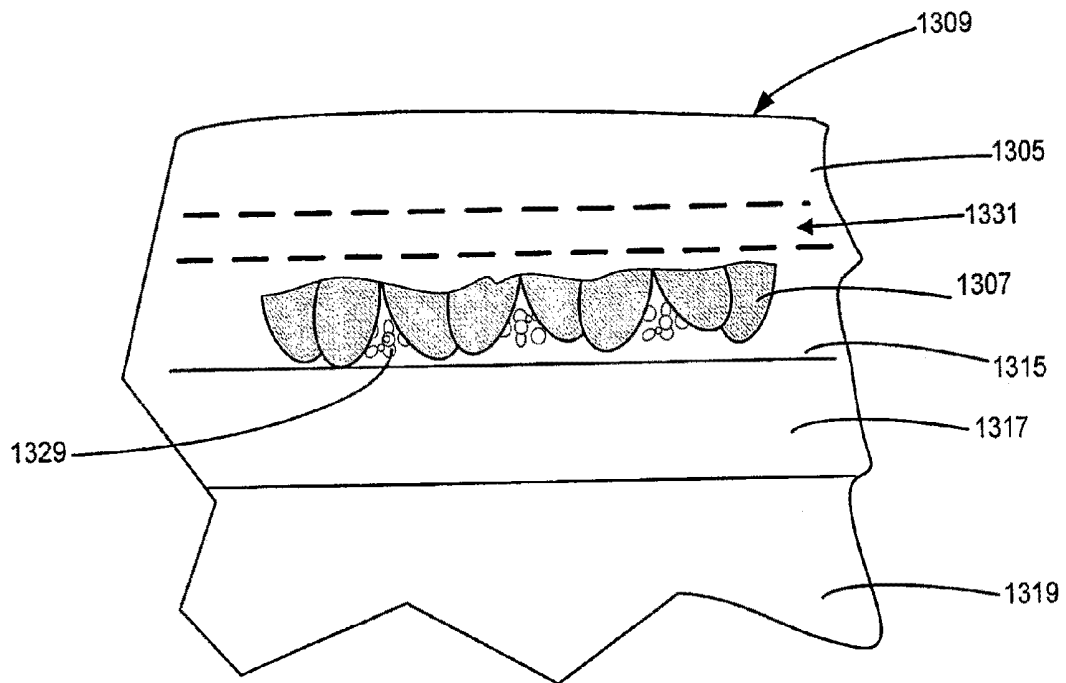

FIG. 16B

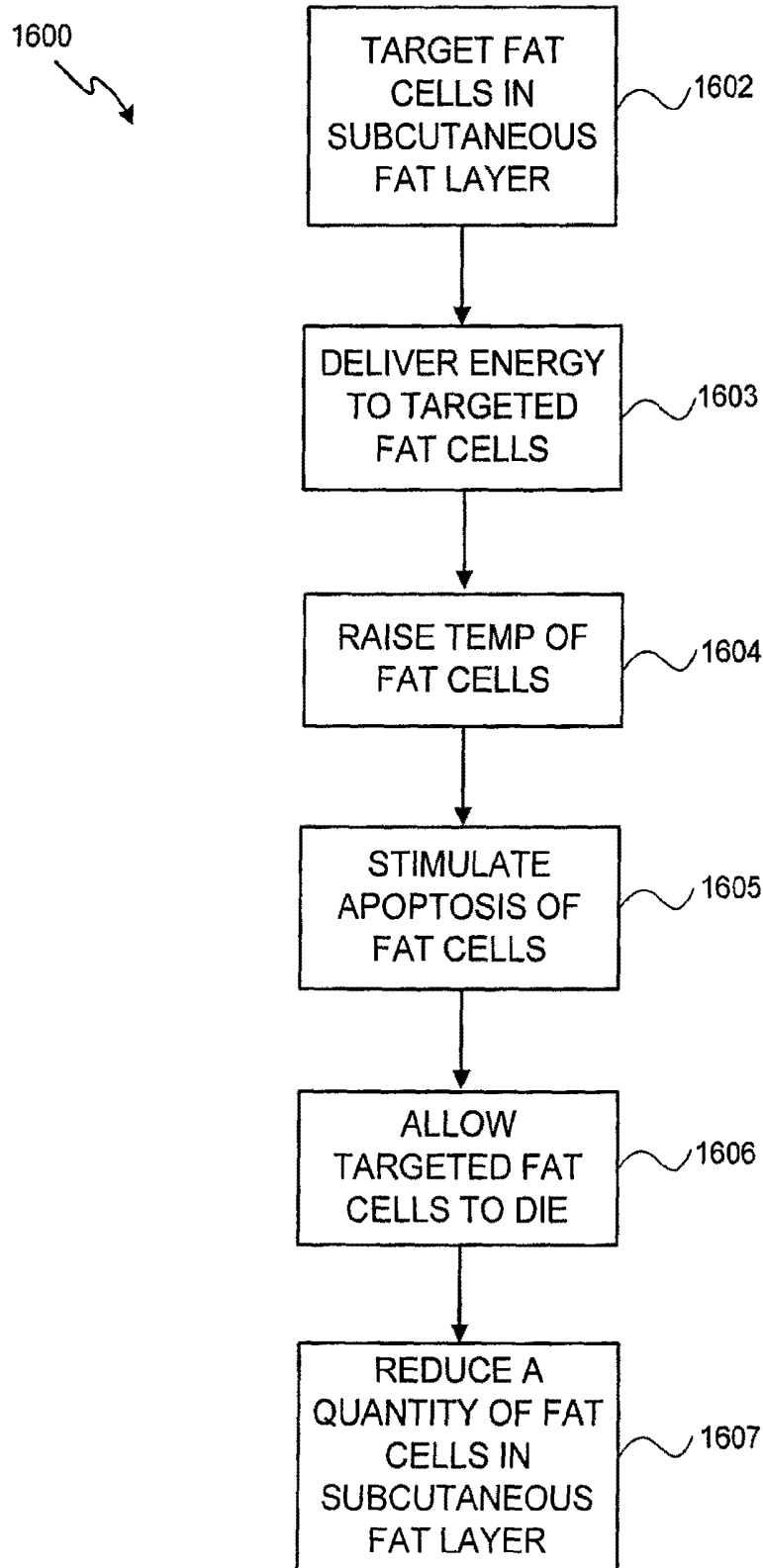

FIG. 17

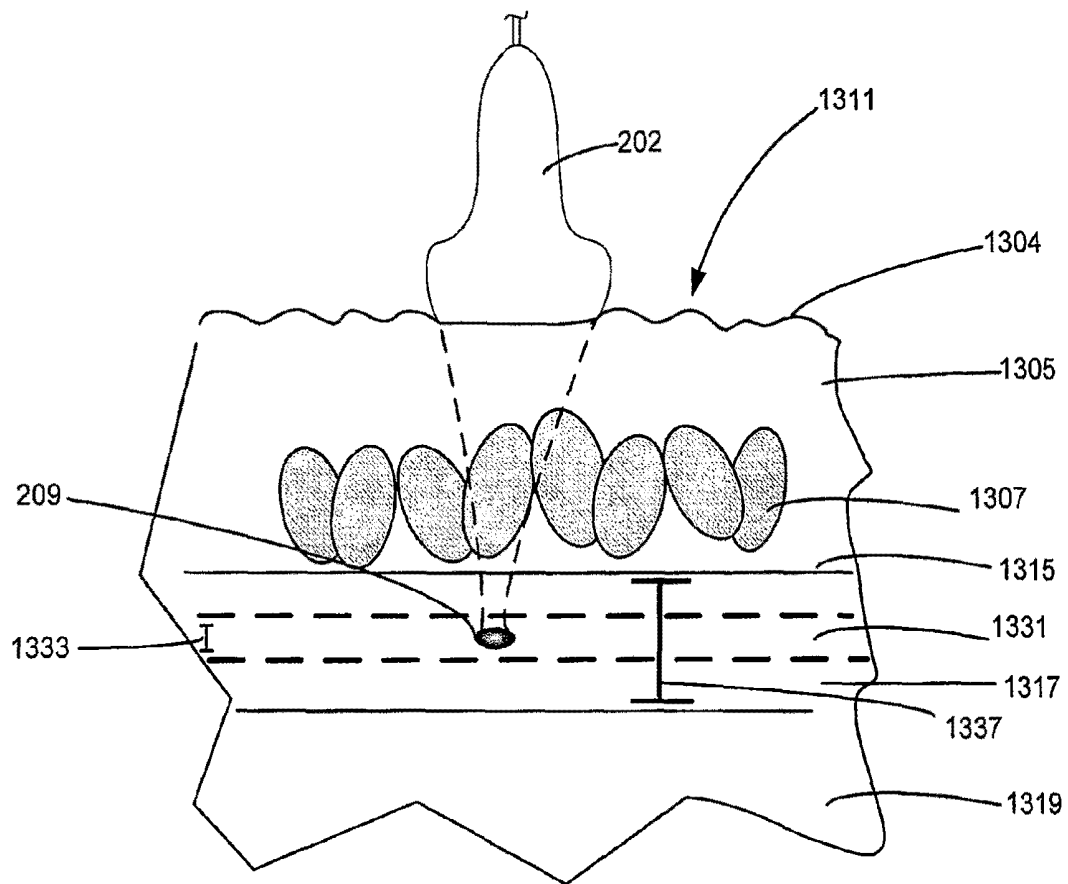

FIG. 18A

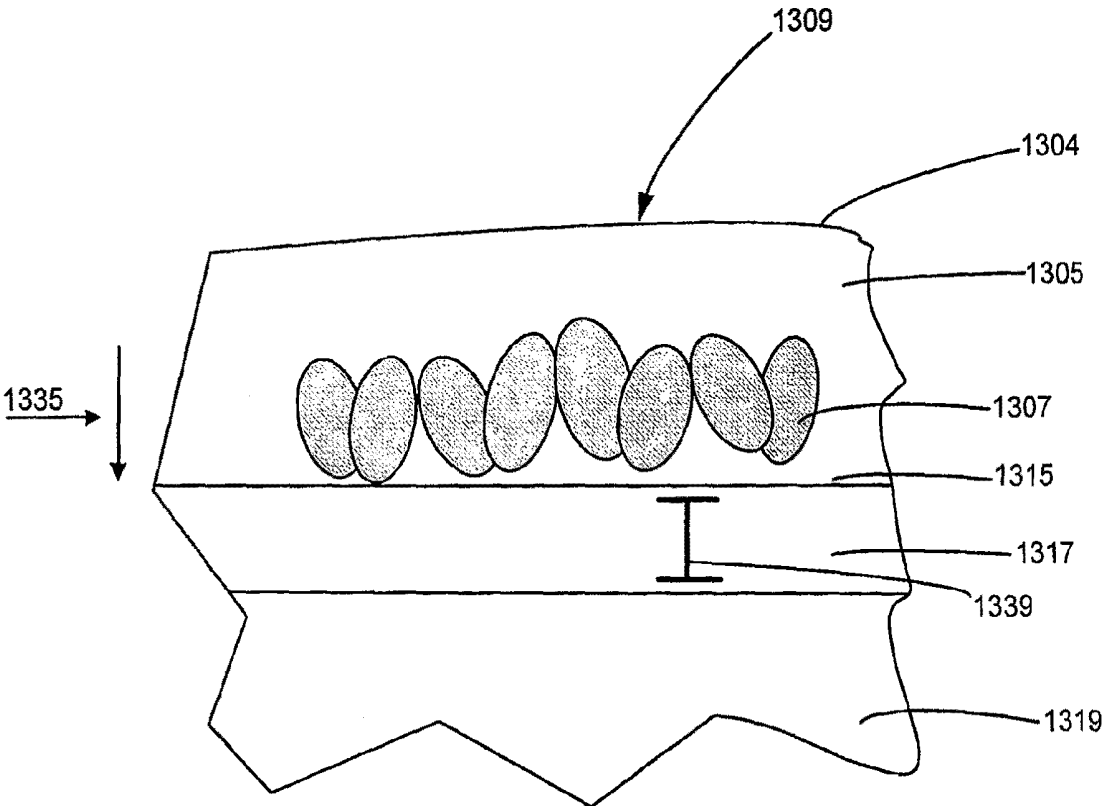

FIG. 18B

ENERGY BASED FAT REDUCTION**CROSS-REFERENCE TO RELATED APPLICATIONS**

This application is a continuation of U.S. application Ser. No. 14/192,520 filed Feb. 27, 2014, now U.S. Pat. No. 8,920,324 issued Dec. 30, 2014, which is a continuation of U.S. application Ser. No. 12/646,609 filed Dec. 23, 2009, now U.S. Pat. No. 8,663,112 issued Mar. 4, 2014, which is a continuation-in-part of U.S. application Ser. No. 11/163,154 filed on Oct. 6, 2005, now U.S. Pat. No. 8,133,180 issued Mar. 13, 2012, which claims the benefit of priority to U.S. Provisional No. 60/616,753 filed on Oct. 6, 2004, each of which are hereby incorporated by reference in their entirety herein. In addition, U.S. application Ser. No. 12/646,609, now U.S. Pat. No. 8,663,112 issued Mar. 4, 2014, claims the benefit of priority from U.S. Provisional No. 61/140,725 filed on Dec. 24, 2008, which is hereby incorporated by reference in its entirety herein. Any and all priority claims identified in the Application Data Sheet, or any correction thereto, are hereby incorporated by reference under 37 CFR 1.57.

BACKGROUND**1. Field of the Invention**

The present invention relates to ultrasound therapy systems, and in particular to methods and systems for treating cellulite or reducing fat.

2. Description of the Related Art

In general, cellulite refers to a common skin disorder which is characterized by a dimple appearance in a person's skin that may be found on the hips, thighs, and/or buttocks. Underneath the dermis and epidermis layers of the skin there are multiple layers of fat. Cellulite tends to develop in the subcutaneous fat layers, which is unique as compared to other fat layers because the subcutaneous fat can be structured into specific chambers surrounded by strands of linked tissue, which are known as fat lobuli. This appearance is much more common in women than in men because of differences in the way fat, muscle, and connective tissue are distributed in men's and women's skin. The lumpiness of cellulite is caused by the fat lobuli that push and distort the connective tissues beneath the skin; resulting protrusions and depressions of connective tissue anchor points create the appearance of cellulite.

Invasive treatments for cellulite include Iontophoresis, liposuction, and electrolipophoresis, which can involve an application of a low-frequency electric current. Non-invasive treatments for cellulite can include laser and suction massage combination therapy, pneumatic pressure massage therapy, lymphatic drainage massage, and low-frequency ultrasound diathermy. Such invasive and non-invasive treatments have yielded marginal results. In addition, a number of drugs that act on fatty tissue have been tried as therapeutic agents for cellulite treatment. Such drugs can be administered orally, applied topically as ointments, or by trans-dermal injection. At this point, no drug has been reported in the scientific literature as having a significant effect on cellulite. New developments for the treatment of cellulite are needed.

In addition, similar techniques have attempted to address the reduction of fat in humans, but such attempts have likewise had mixed results.

SUMMARY

In accordance with various aspects of the present invention, non-invasive methods and systems for fat reduction and/

or treatment of cellulite are provided. In accordance with an exemplary embodiment, a non-invasive method for cellulite treatment can include targeting a region of interest below a surface of skin, which contains fat lobuli and delivering ultrasound energy to the region of interest. The ultrasound energy generates a conformal lesion with said ultrasound energy on a surface of a fat lobuli. The lesion creates an opening in the surface of the fat lobuli, which allows the draining of a fluid out of the fat lobuli and through the opening.

In accordance with an exemplary embodiment, a non-invasive method for cellulite treatment can include targeting fat cells in a subcutaneous fat layer and delivering ultrasound energy to raise the temperature of the fat cells, stimulating apoptosis of the fat cells and then allowing the targeted fat cells to die, thereby reducing a quantity of fat cells in the subcutaneous layer.

Further areas of applicability will become apparent from the description provided herein. It should be understood that the description and specific examples are intended for purposes of illustration only and are not intended to limit the scope of the present invention.

BRIEF DESCRIPTION OF THE DRAWINGS

The drawings described herein are for illustration purposes only and are not intended to limit the scope of the present disclosure in any way. The present invention will become more fully understood from the detailed description and the accompanying drawings wherein:

FIG. 1 illustrates a block diagram of an ultrasound treatment system for treating cellulite in accordance with exemplary embodiments of the present invention;

FIG. 2 illustrates a cross-sectional diagram of a transducer system in accordance with exemplary embodiments of the present invention;

FIGS. 3A and 3B illustrate block diagrams of an exemplary control system in accordance with exemplary embodiments of the present invention;

FIGS. 4A and 4B illustrate block diagrams of an exemplary probe system in accordance with exemplary embodiments of the present invention;

FIG. 5 illustrates a cross-sectional diagram of an exemplary transducer in accordance with exemplary embodiments of the present invention;

FIGS. 6A and 6B illustrate cross-sectional diagrams of an exemplary transducer in accordance with exemplary embodiments of the present invention;

FIG. 7 illustrates exemplary transducer configurations for ultrasound treatment in accordance with exemplary embodiments of the present invention;

FIGS. 8A and 8B illustrate cross-sectional diagrams of an exemplary transducer in accordance with exemplary embodiments of the present invention;

FIG. 9 illustrates an exemplary transducer configured as a two-dimensional array for ultrasound treatment in accordance with exemplary embodiments of the present invention;

FIGS. 10A-10F illustrate cross-sectional diagrams of exemplary transducers in accordance with exemplary embodiments of the present invention;

FIG. 11 illustrates a schematic diagram of an acoustic coupling and cooling system in accordance with exemplary embodiments of the present invention;

FIG. 12 illustrates a block diagram of a treatment system comprising an ultrasound treatment subsystem combined with additional subsystems and methods of treatment moni-

toring and/or treatment imaging as well as a secondary treatment subsystem in accordance with exemplary embodiments of the present invention;

FIG. 13 is a cross-sectional diagram illustrating a method of treating cellulite in accordance with exemplary embodiments of the present invention;

FIGS. 14A and 14B are cross-sectional diagrams illustrating another method of treating cellulite in accordance with exemplary embodiments of the present invention;

FIG. 15 is a block diagram illustrating a method of treating cellulite in accordance with exemplary embodiments of the present invention;

FIGS. 16A and 16B are cross-sectional diagrams illustrating a method of reducing fat and treating cellulite in accordance with exemplary embodiments of the present invention;

FIG. 17 is a block diagram illustrating a method of fat reduction in accordance with exemplary embodiments of the present invention; and

FIGS. 18A and 18B are cross-sectional diagrams illustrating a method of reducing fat in accordance with exemplary embodiments of the present invention.

DETAILED DESCRIPTION

The following description is merely exemplary in nature and is not intended to limit the present invention or its teachings, applications, or uses thereof. It should be understood that throughout the drawings, corresponding reference numerals indicate like or corresponding parts and features. The description of specific examples indicated in various embodiments and aspects of the present invention are intended for purposes of illustration only and are not intended to limit the scope of the invention disclosed herein. Moreover, recitation of multiple embodiments having stated features is not intended to exclude other embodiments having additional features or other embodiments incorporating different combinations of the stated features.

The present invention may be described herein in terms of various functional components and processing steps. It should be appreciated that such components and steps may be realized by any number of hardware components configured to perform the specified functions. For example, the present invention may employ various medical treatment devices, visual imaging and display devices, input terminals and the like, which may carry out a variety of functions under the control of one or more control systems or other control devices. In addition, the present invention may be practiced in any number of medical or cosmetic contexts and the exemplary embodiments relating to a non-invasive methods and systems for fat reduction and/or cellulite treatment as described herein are merely indicative of exemplary applications for the invention. For example, various of the principles, features and methods discussed herein may be applied to any medical or cosmetic application, or other related applications.

Various aspects of the present invention provide a method of non-invasive treatment of cellulite. The method includes targeting a region of interest below a surface of skin, which contains fat lobuli and delivering ultrasound energy to the region of interest. The ultrasound energy generates a conformal lesion within the ultrasound energy on a surface of a fat lobuli, such as, for example, by creating a sharp focal of ultrasound energy onto the fat lobuli. The lesion creates an opening in the surface of the fat lobuli, such as, for example, by piercing the fat lobuli, which allows the draining of a fluid out of the fat lobuli through the opening.

Various aspects of the present invention can also provide a method for fat reduction that can include heating a region of

interest to a temperature in a range from about 43° C. to about 49° C., which can stimulate apoptosis of at least one fat cell in the fat lobuli. Still further, the method can include applying a physical treatment to said surface of skin and such physical treatment can include mesotherapy, iontophoresis, pressotherapy, pneumatic massage, lymphatic drainage, electroli-pophoresis, roller massage, low frequency ultrasound, vacuum suction, laser energy, and application of RF energy. The physical treatment can be before, after, or concurrent with the delivery of the ultrasound energy. The method can include the use of a second energy, which can be used before, after, or concurrent with the delivery of the ultrasound energy. The method can reduce the appearance of cellulite on the surface of skin.

Various aspects of the present invention provide a method of non-invasively stimulating apoptosis of a fat cell located in a subcutaneous fat layer. The method include targeting at least one fat cell in a subcutaneous layer below a skin surface and delivering energy to the fat cell. The delivered energy raises a temperature of the fat cell into a range from about 43° C. to about 49° C., which stimulates apoptosis of the fat cell.

The method can further include imaging of the fat cell. Still further, the method can include generating a conformal lesion into said at least one fat cell, which can create an opening in the fat cell and allow the moving of a material out of the fat cell through the opening. The energy is typically ultrasound energy in the range of about 750 kHz to about 20 MHz or in a range from about 2 MHz to about 20 MHz, or other more specific ranges. Still further the method can include applying a physical treatment to said surface of skin and such physical treatment can include mesotherapy, iontophoresis, pressotherapy, pneumatic massage, lymphatic drainage, electroli-pophoresis, roller massage, low-frequency ultrasound, vacuum suction, laser energy, and application of RF energy. The physical treatment can be before, after, or concurrent with the delivery of the energy. The method can include the use of a second energy, which can be used before, after, or concurrent with the delivery of the energy. The method can reduce the number of fat cells in the subcutaneous fat layer.

In addition, various aspects of the present invention provide a method that combines fat reduction and cellulite reduction. The method includes targeting a region of interest below a surface of skin, which contains fat lobuli, and delivering ultrasound energy to the region of interest. The ultrasound energy generates a conformal lesion with said ultrasound energy on a surface of a fat lobuli. The lesion creates an opening in the surface of the fat lobuli, which allows the draining of a fluid out of the fat lobuli through the opening. Additionally, the method can include targeting at least one fat cell in a subcutaneous layer below a skin surface and delivering a second energy to the fat cell. The delivered second energy raises a temperature of the fat cell into a range from about 43° C. to about 49° C., which stimulates apoptosis of the fat cell.

The method can further include a physical treatment as described herein, as well as the use of a secondary energy source. The method can both reduce the number of fat cells in the subcutaneous fat layer and reduce the appearance of cellulite on a skin surface. The method can be effective in physically breaking fat cell clusters and stretching fibrous bonds of cellulite.

In accordance with an exemplary embodiment, a method of non-invasive treatment of cellulite can include targeting a region of interest below a skin surface, which contains fat lobuli, and delivering ultrasound energy at a specified depth below the skin surface. The method further includes moving

a source of the energy along the skin surface and ablating a portion of the fat lobuli at the specified depth below the skin surface.

In accordance with the exemplary method, a specified depth is generally in the range of about 1 mm to about 35 mm below the skin surface. The method can include applying a physical treatment as described herein. The method can smooth the skin surface and may reduce the appearance of cellulite on the skin surface. The method can further include any of the additional method steps discussed herein.

In accordance with various aspects of the present invention, non-invasive methods and systems for the reduction of fat and/or the treating of cellulite are provided. For example, in accordance with an exemplary embodiment, with reference to FIG. 1, an exemplary treatment system **100** configured to treat a region of interest **106** comprises a control system **102**, an imaging/therapy probe with acoustic coupling **104**, and a display system **108**.

Control system **102** and display system **108** can comprise various configurations for controlling probe **104** and overall system **100** functionality. In various embodiments, control system **102** can include, for example but not limited to any of the following, a microprocessor with software and a plurality of input/output devices, systems or devices for controlling electronic and/or mechanical scanning and/or multiplexing of transducers, systems for power delivery, systems for monitoring, systems for sensing the spatial position of the probe and/or transducers, and/or systems for handling user input and recording treatment results, among others. Imaging/therapy probe **104** can comprise various probe and/or transducer configurations. For example, probe **104** can be configured for a combined dual-mode imaging/therapy transducer, coupled or co-housed imaging/therapy transducers, or simply a separate therapy probe and an imaging probe.

In accordance with an exemplary embodiment, treatment system **100** is configured for treating a deep tissue region that contains a lower part of dermis and proximal protrusions of fat lobuli into the dermis by, first, imaging region of interest (“ROI”) **210** for localization of the treatment area and surrounding structures, second, delivering ultrasound energy at a depth, distribution, timing, and energy level to achieve the desired therapeutic effect, and third monitoring the treatment area before, during, and after therapy to plan and assess the results and/or provide feedback. As to the delivery of energy, control system **102** and transducer system **102** can be suitably configured to deliver conformal ultrasound therapeutic energy to ROI **210** creating a thermal injury and coagulating the proximal protrusions of fat lobuli, thereby eliminating the fat protrusions into the dermis. As used herein, the term “dermis” refers to any part of the dermis and/or the epidermis.

Because the location and thickness of the fat lobuli varies from one patient to another (due to genetics, weight, age, etc.), imaging using a transducer can facilitate treatment within a patient, however imaging is not required to treat cellulite.

By planning a treatment protocol, the user may choose one or more spatial and/or temporal characteristics to provide conformal ultrasound energy to ROI **210**. For example, the user may select one or more spatial characteristics to control, including, for example, the use of one or more transducers, one or more mechanical and/or electronic focusing mechanisms, one or more transduction elements, one or more placement locations of the transducer relative to ROI **210**, one or more feedback systems, one or more mechanical arms, one or more orientations of the transducer, one or more temperatures of treatment, one or more coupling mechanisms and/or the like.

In addition, the user may choose one or more temporal characteristics to control in order to facilitate treatment of ROI **210**. For example, the user may select and/or vary the treatment time, frequency, power, energy, amplitude and/or the like in order to facilitate temporal control. For more information on selecting and controlling ultrasound spatial and temporal characteristics, see U.S. application Ser. No. 11/163,148, entitled “Method and System for Controlled Thermal Injury”, filed Oct. 6, 2005, published on Jun. 1, 2006 as U.S. Patent Application Publication No. 20060116671, and incorporated herein by reference.

After planning of a treatment protocol is complete, the treatment protocol can be implemented. That is, a transducer system can be used to deliver ultrasound energy to a treatment region to ablate select tissue in order to facilitate cellulite treatment. By delivering energy, the transducer may be driven at a select frequency, a phased array may be driven with certain temporal and/or spatial distributions, a transducer may be configured with one or more transduction elements to provide focused, defocused and/or planar energy, and/or the transducer may be configured and/or driven in any other ways hereinafter devised.

For treatment of ROI **210**, transducer system **102** may be configured to deliver one or more energy fields to promote one or more effects, for example, ablation of existing tissue, the breaking up of fat cell clusters, stretching of the fibrous bonds, enhancement of lymphatic drainage, stimulation of the evacuation of fat decay products, and/or enhanced cell permeability in order to treat cellulite. Additionally, for treatment of ROI **210**, transducer system **102** may be configured to deliver one or more energy fields to promote one or more effects, for example cell apoptosis, piercing cells to promote drainage, and ablating a layer of fat cells to a specified distance below a skin surface, such as for example giving the fat cells a haircut. Of course transducer system may be configured to deliver one energy field as needed by any of the methods of treatment described herein. As described herein, imaging is not necessary for treatment methods or treatment plans but rather is an optional step. For example, the dimpled pattern of cellulite is typically visible on the surface of a patient’s skin and the system user can easily identify ROI **210** that will be treated.

Through operation of treatment system **100**, a method for treatment of cellulite can be realized that can facilitate effective and efficient therapy without creating chronic injury to human tissue. For example, a user may first select one or more transducer probe configurations for treating ROI **210**. The user may select any probe configuration described herein. Because the treatment region ranges from about 0 mm to greater than about 5.5 cm or from about 1 mm to about 3.5 cm, exemplary transducer probes may include, for example, an annular array, a variable depth transducer, a mechanically moveable transducer, a cylindrical-shaped transducer, a linear or flat transducer and the like. As used herein, the term user may include a person, employee, doctor, nurse, and/or technician, utilizing any hardware and/or software of other control systems.

Once one or more transducers are selected, the user may then image ROI **210** in order to plan a treatment protocol. By imaging ROI **210**, the user may use the same treatment transducer probe and/or one or more additional transducers to image ROI **210** at a high resolution. In one embodiment, the transducer may be configured to facilitate high speed imaging over a large ROI **210** to enable accurate imaging over a large ROI **210**. In another embodiment, ultrasound imaging may include, individually or in combination, the use of Doppler flow monitoring and/or color flow monitoring. In addition,

other means of imaging such as photography and other visual optical methods, MRI, X-Ray, PET, infrared or others can be utilized separately or in combination for imaging and feedback of the superficial tissue and the vascular tissue in ROI 210.

An exemplary ultrasound therapy system of FIG. 1 is further illustrated in an exemplary embodiment in FIG. 2. A therapy transducer system 200 includes a transducer probe 202 connected to control system 204, and display 206, in combination may provide therapy, imaging, and/or temperature or other tissue parameters monitoring to ROI 210. Exemplary transducer system 200 is configured for, first, imaging and display of ROI 210 for localization of the treatment area and surrounding structures, second, delivery of focused, unfocused, or defocused ultrasound energy at a depth, distribution, timing, and energy level to achieve the desired therapeutic effect of thermal ablation to treat cellulite, and, third, to monitor the treatment area and surrounding structures before, during, and after therapy to plan and assess the results and/or provide feedback to control system 204 and/or an operator.

Exemplary transducer probe 202 can be configured to be suitably controlled and/or operated in various manners. For example, transducer probe 202 may be configured for use within an ultrasound treatment system, an ultrasound imaging system and/or an ultrasound imaging, therapy, and/or treatment monitoring system, including motion control subsystems.

Control system 204 can be configured with one or more subsystems, processors, input devices, displays and/or the like. Display 206 may be configured to image and/or monitor ROI 210 and/or any particular sub-region within ROI 210. Display 206 can be configured for two-dimensional, three-dimensional, real-time, analog, digital and/or any other type of imaging. Exemplary embodiments of both control system 204 and display 206 are described in greater detail herein.

ROI 210, can be comprised of superficial layer (epidermis/dermis) subcutaneous fat, lobuli, and muscle. Exemplary transducer system 200 is configured to provide cross-sectional two-dimensional imaging of the region 207, displayed as an image 205, with a controlled thermal lesion 209, confined approximately to proximal portion of fat lobuli and lower portion of dermis.

Transducer system 200 can be configured with the ability to controllably produce conformal treatment areas in superficial human tissue within ROI 210 through precise spatial and temporal control of acoustic energy deposition. In accordance with an exemplary embodiment, control system 204 and transducer probe 202 can be suitably configured for spatial control of the acoustic energy by controlling the manner of distribution of the acoustical energy. For example, spatial control may be realized through selection of the type of one or more transducer configurations insinuating ROI 210, selection of the placement and location of transducer probe 202 for delivery of acoustical energy relative to ROI 210, e.g., transducer probe 202 configured for scanning over part or whole of ROI 210 to deliver conformal ultrasound therapeutic energy to create a thermal injury, such as a lesion, and to coagulate the proximal protrusions of fat lobuli, thereby eliminating the fat protrusions into the dermis. Transducer probe 202 may also be configured for control of other environment parameters, e.g., the temperature at the acoustic coupling interface can be controlled. In addition to the spatial control, control system 204 and/or transducer probe 202 can also be configured for temporal control, such as through adjustment and optimization of drive amplitude levels, frequency/waveform selections, and timing sequences and other energy drive characteristics to control the treatment of tissue. The spatial and/

or temporal control can also be facilitated through open-loop and closed-loop feedback arrangements, such as through the monitoring of various positional and temporal characteristics. For example, through such spatial and/or temporal control, an exemplary treatment system 200 can enable the regions of thermal injury to possess arbitrary shape and size and allow the tissue to be treated in a controlled manner.

Transducer system 200 may be used to provide a mechanical action of ultrasound to physically break fat cell clusters and stretch the fibrous bonds. This mechanical action will also enhance lymphatic drainage, stimulating the evacuation of fat decay products. That is, the ultrasound may facilitate movement of the muscles and soft tissues within ROI 210, thereby facilitating the loosening of fat deposits and/or the break up of fibrous tissue surrounding fat deposits.

In addition, transducer system 200 can be configured to deliver various therapeutic levels of ultrasound to increase the speed at which fat metabolizes, according to Arrhenius' Law: $K=Ae^{sup.-B/T}$, where K is the kinetic rate of fat metabolization, A is a constant, B is the activation energy, and T is the temperature in degrees Kelvin. According to Arrhenius' Law, a metabolic reaction is a function of temperature. In exemplary embodiments, transducer system 200 is configured to provide various therapeutic levels of ultrasound to increase a temperature of fat cells in order to maximize the speed at which fat metabolizes. Moreover, transducer system 200 can be configured to deliver various therapeutic levels of ultrasound to increase the speed at which fat metabolizes. According to a modified equation of Arrhenius' Law, a metabolic reaction is a function of temperature and time, $T: K=Ate^{sup.-B/T}$, where K is the kinetic rate of fat metabolization, A is a constant, B is the activation energy, t is time, and T is the temperature in degrees Kelvin. In exemplary embodiments, transducer system 200 is configured to provide various therapeutic levels of ultrasound for a specified time period or for a pulsed delivery over time to increase a temperature of fat cells in order to maximize the speed at which fat metabolizes. Moreover, transducer system 200 can be configured to deliver various therapeutic levels of ultrasound for a specified time period or for a pulsed delivery over time to increase the speed at which fat metabolizes. Thus, ultrasound treatment from transducer system 200, ranging from approximately 750 kHz to 20 MHz, can increase the temperature in a treatment area, thereby increasing the metabolic reaction yield for that treatment area. As such, fat metabolism in the treatment area is increased which leads to fat cell reduction and decreases the appearance of cellulite above the treatment area. Ultrasound treatment from transducer 200 can be programmed to provide appropriate temperatures and optionally for appropriate time to ROI 210 to increase the spread of fat cell metabolism leading to fat cell destruction and optionally reducing the appearance of cellulite.

In some aspects of the present invention, a method of increasing metabolism of fat cells in a subcutaneous fat layer is provided. The method can include targeting a plurality of fat cells in a subcutaneous fat layer, heating the plurality of fat cells to a temperature as defined by Arrhenius' Law, increasing a metabolism of at least a portion of the plurality of fat cells, and reducing a portion of the plurality of fat cells. The method can also include any physical treatment described herein before, after, and/or concurrent with increasing the metabolism of the fat cells. In addition, the method can include the use a secondary energy as described herein.

As previously described, control systems 104 and 204 may be configured in a variety of manners with various subsystems and subcomponents. With reference to FIGS. 3A and 3B, in accordance with exemplary embodiments, an exem-

plary control system **300** can be configured for coordination and control of the entire therapeutic treatment process in accordance with the adjustable settings made by a therapeutic treatment system user. For example, control system **300** can suitably comprise power source components **302**, sensing and monitoring components **304**, cooling and coupling controls **306**, and/or processing and control logic components **308**. Control system **300** can be configured and optimized in a variety of ways with more or less subsystems and components to implement the therapeutic system for cellulite treatment, and the embodiment in FIGS. 3A and 3B are merely for illustration purposes.

For example, for power sourcing components **302**, control system **300** can comprise one or more direct current (DC) power supplies **303** configured to provide electrical energy for entire control system **300**, including power required by transducer electronic amplifier/driver **312**. DC current sense device **305** can also be provided to confirm the level of power going into amplifiers/drivers **312** for safety and monitoring purposes.

Amplifiers/drivers **312** can comprise multi-channel or single channel power amplifiers and/or drivers. In accordance with an exemplary embodiment for transducer array configurations, amplifiers/drivers **312** can also be configured with a beamformer to facilitate array focusing. An exemplary beamformer can be electrically excited by an oscillator/digitally controlled waveform synthesizer **310** with related switching logic.

Power sourcing components **302** can also include various filtering configurations **314**. For example, switchable harmonic filters and/or matching may be used at the output of amplifier/driver **312** to increase the drive efficiency and effectiveness. Power detection components **316** may also be included to confirm appropriate operation and calibration. For example, electric power and other energy detection components **316** may be used to monitor the amount of power going to an exemplary probe system.

Various sensing and monitoring components **304** may also be suitably implemented within control system **300**. For example, in accordance with an exemplary embodiment, monitoring, sensing and interface control components **324** may be configured to operate with various motion detection systems implemented within transducer probe **104** to receive and process information such as acoustic or other spatial and temporal information from ROI **210**. Sensing and monitoring components can also include various controls, interfacing and switches **309** and/or power detectors **316**. Such sensing and monitoring components **304** can facilitate open-loop and/or closed-loop feedback systems within treatment system **100**.

For example, in such an open-loop system, a system user can suitably monitor the imaging and/or other spatial or temporal parameters and then adjust or modify the same to accomplish a particular treatment objective. Instead of, or in combination with, open-loop feedback configurations, an exemplary treatment system can comprise a closed-loop feedback system, wherein images and/or spatial/temporal parameters can be suitably monitored within monitoring components **304** to generate signals.

During operation of exemplary treatment system **100**, a lesion configuration of a selected size, shape, and orientation is determined. Based on that lesion configuration, one or more spatial parameters are selected, along with suitable temporal parameters, the combination of which yields the desired conformal lesion. Operation of the transducer can then be initiated to provide the conformal lesion or lesions. Open and/or closed-loop feedback systems can also be imple-

mented to monitor the spatial and/or temporal characteristics, and/or other tissue parameter monitoring, to further control the conformal lesions.

Cooling/coupling control systems **306** may be provided to remove waste heat from exemplary probe **104**, provide a controlled temperature at the superficial tissue interface and deeper into tissue, and/or provide acoustic coupling from transducer probe **104** to ROI **210**. Such cooling/coupling control systems **306** can also be configured to operate in both open-loop and/or closed-loop feedback arrangements with various coupling and feedback components.

Processing and control logic components **308** can comprise various system processors and digital control logic **307**, such as one or more of microcontrollers, microprocessors, field-programmable gate arrays (FPGAs), computer boards, and associated components, including firmware and control software **326**, which interfaces to user controls and interfacing circuits as well as input/output circuits and systems for communications, displays, interfacing, storage, documentation, and other useful functions. System software and firmware **326** controls all initialization, timing, level setting, monitoring, safety monitoring, and all other system functions required to accomplish user-defined treatment objectives. Further, various control switches **308** can also be suitably configured to control operation.

An exemplary transducer probe **104** can also be configured in various manners and can comprise a number of reusable and/or disposable components and parts in various embodiments to facilitate its operation. For example, transducer probe **104** can be configured within any type of transducer probe housing or arrangement for facilitating the coupling of a transducer to a tissue interface, with such housing comprising various shapes, contours and configurations depending on the particular treatment application. For example, in accordance with an exemplary embodiment, transducer probe **104** can be depressed against a tissue interface whereby blood perfusion is partially or wholly cut-off, and tissue is flattened in superficial treatment ROI **210**. Transducer probe **104** can comprise any type of matching, such as for example, electric matching, which may be electrically switchable; multiplexer circuits and/or aperture/element selection circuits; and/or probe identification devices, to certify probe handle, electric matching, transducer usage history and calibration, such as one or more serial EEPROM (memories).

Transducer probe **104** may also comprise cables and connectors; motion mechanisms, motion sensors and encoders; thermal monitoring sensors; and/or user control and status related switches, and indicators such as LEDs. For example, a motion mechanism in probe **104** may be used to controllably create multiple lesions, or sensing of probe motion itself may be used to controllably create multiple lesions and/or stop creation of lesions, e.g. for safety reasons if probe **104** is suddenly jerked or is dropped. In addition, an external motion encoder arm may be used to hold the probe during use, whereby the spatial position and attitude of probe **104** is sent to the control system to help controllably create lesions. Furthermore, other sensing functionality such as profilometers or other imaging modalities may be integrated into the probe in accordance with various exemplary embodiments.

With reference to FIGS. 4A and 4B, in accordance with an exemplary embodiment, transducer probe **400** can comprise control interface **402**, transducer **404**, coupling components **406**, and monitoring/sensing components **408**, and/or motion mechanism **410**. However, transducer probe **400** can be configured and optimized in a variety of ways with more or less parts and components to provide ultrasound energy for cellulite treatment and/or fat reduction, and the embodiments

illustrated in FIGS. 4A and 4B are merely for illustration purposes. In some embodiments, transducer probe 104 is equivalent to transducer probe 400. In some embodiments, transducer probe 104, discussed above, can comprise control interface 402, transducer 404, coupling components 406, and monitoring/sensing components 408, and/or motion mechanism 410.

In accordance with an exemplary embodiment of the present invention, transducer probe 400 is configured to deliver energy over varying temporal and/or spatial distributions in order to provide energy effects and initiate responses in ROI 210. These effects can include, for example, thermal, cavitation, hydrodynamic, and resonance induced tissue effects. For example, exemplary transducer probe 400 can be operated under one or more frequency ranges to provide two or more energy effects and initiate one or more responses in ROI 210. In addition, transducer probe 400 can also be configured to deliver planar, defocused and/or focused energy to ROI 210 to provide two or more energy effects and to initiate one or more reactions. These responses can include, for example, diathermy, hemostasis, revascularization, angiogenesis, growth of interconnective tissue, tissue reformation, ablation of existing tissue, protein synthesis, cell apoptosis, and/or enhanced cell permeability.

These and various other exemplary embodiments of systems and components for such combined ultrasound treatment, effects and responses are more fully set forth in U.S. patent application Ser. No. 10/950,112, entitled "Method and System for Combined Ultrasound Treatment", filed Sep. 24, 2004, published on Apr. 6, 2006 as U.S. Patent Application Publication No. 20060074355, and incorporated herein by reference.

In addition, these and various other exemplary embodiments of systems and components for such combined ultrasound treatment, effects and responses are more fully set forth in U.S. Pat. No. 6,050,943, entitled "Imaging, Therapy, and Temperature Monitoring Ultrasonic System", issued Apr. 18, 2000, and U.S. Pat. No. 6,500,121 entitled "Imaging, Therapy, and temperature Monitoring Ultrasonic System," issued Dec. 31, 2002, both of which are incorporated herein by reference.

Control interface 402 is configured for interfacing with control system 300 to facilitate control of transducer probe 400. Control interface components 402 can comprise multiplexer/aperture select 424, switchable electric matching networks 426, serial EEPROMs and/or other processing components and matching and probe usage information 430 and interface connectors 432.

Coupling components 406 can comprise various devices to facilitate coupling of transducer probe 400 to ROI 210. For example, coupling components 406 can comprise cooling and acoustic coupling system 420 configured for acoustic coupling of ultrasound energy and signals. Coupling system 420 with possible connections such as manifolds may be utilized to couple sound into ROI 210, control temperature at the interface and deeper into tissue, provide liquid-filled lens focusing, and/or to remove transducer waste heat. Coupling system 420 may facilitate such coupling through use of various coupling mediums, including air and other gases, water and other fluids, gels, solids, and/or any combination thereof, or any other medium that allows for signals to be transmitted between transducer active elements 412 and ROI 210. In addition to providing a coupling function, in accordance with an exemplary embodiment, coupling system 420 can also be configured for providing temperature control during the treatment application. For example, coupling system 420 can be configured for controlled cooling of an interface surface or

region between transducer probe 400 and ROI 210 and beyond by suitably controlling the temperature of the coupling medium. The suitable temperature for such coupling medium can be achieved in various manners, and utilize various feedback systems, such as thermocouples, thermistors or any other device or system configured for temperature measurement of a coupling medium. Such controlled cooling can be configured to further facilitate spatial and/or thermal energy control of transducer probe 400.

Monitoring and sensing components 408 can comprise various motion and/or position sensors 416, temperature monitoring sensors 418, user control and feedback switches 414 and other like components for facilitating control by control system 300, e.g., to facilitate spatial and/or temporal control through open-loop and closed-loop feedback arrangements that monitor various spatial and temporal characteristics.

Motion mechanism 410 can comprise manual operation, mechanical arrangements, or some combination thereof. For example, motion mechanism 422 can be suitably controlled by control system 300, such as through the use of accelerometers, encoders or other position/orientation devices 416 to determine and enable movement and positions of transducer probe 400. Linear, rotational or variable movement can be facilitated, e.g., those depending on the treatment application and tissue contour surface.

Transducer 404 can comprise one or more transducers configured for producing conformal lesions of thermal injury in superficial human tissue within ROI 210 through precise spatial and temporal control of acoustic energy deposition. Transducer 404 can also comprise one or more transduction elements and/or lenses 412. The transduction elements can comprise a piezoelectrically active material, such as lead zirconate titanate (PZT), or any other piezoelectrically active material, such as a piezoelectric ceramic, crystal, plastic, and/or composite materials, as well as lithium niobate, lead titanate, barium titanate, and/or lead metaniobate. In addition to, or instead of, a piezoelectrically active material, transducer 404 can comprise any other materials configured for generating radiation and/or acoustical energy. Transducer 404 can also comprise one or more matching layers configured along with the transduction element such as coupled to the piezoelectrically active material. Acoustic matching layers and/or damping may be employed as necessary to achieve the desired electroacoustic response.

In accordance with an exemplary embodiment, the thickness of the transduction element of transducer 404 can be configured to be uniform. That is, transduction element 412 can be configured to have a thickness that is substantially the same throughout. In accordance with another exemplary embodiment, the thickness of transduction element 412 can also be configured to be variable. For example, transduction element(s) 412 of transducer 404 can be configured to have a first thickness selected to provide a center operating frequency of a lower range, for example from approximately 750 kHz to 5 MHz. Transduction element 404 can also be configured with a second thickness selected to provide a center operating frequency of a higher range, for example from approximately 5 MHz to 20 MHz or more. Transducer 404 can be configured as a single broadband transducer excited with at least two or more frequencies to provide an adequate output for generating a desired response. Transducer 404 can also be configured as two or more individual transducers, wherein each transducer comprises one or more transduction element. The thickness of the transduction elements can be configured to provide center-operating frequencies in a desired treatment range. For example, transducer 404 can

comprise a first transducer configured with a first transduction element having a thickness corresponding to a center frequency range of approximately 750 kHz to 5 MHz, and a second transducer configured with a second transduction element having a thickness corresponding to a center frequency of approximately 5 MHz to 20 MHz or more.

Transducer **404** may be composed of one or more individual transducers in any combination of focused, planar, or unfocused single-element, multi-element, or array transducers, including 1-D, 2-D, and annular arrays; linear, curvilinear, sector, or spherical arrays; spherically, cylindrically, and/or electronically focused, defocused, and/or lensed sources.

In accordance with another exemplary embodiment, transducer probe **400** may be suitably configured to provide three-dimensional treatment. For example, to provide three-dimensional treatment of ROI **210**, with reference again to FIG. **4**, a three-dimensional system can comprise transducer probe **400** configured with an adaptive algorithm, such as, for example, one utilizing three-dimensional graphic software, contained in a control system, such as for example control system **300**. The adaptive algorithm is suitably configured to receive two-dimensional imaging, temperature monitoring and/or treatment information relating to ROI **210**, process the received information, and then provide corresponding three-dimensional imaging, temperature and/or treatment information.

In accordance with another aspect of the invention, transducer probe **400** may be configured to provide one, two or three-dimensional treatment applications for focusing acoustic energy to one or more regions of interest. For example, as discussed above, transducer probe **400** can be suitably diced to form a one-dimensional array, e.g., a transducer comprising a single array of sub-transduction elements.

For example, with reference to an exemplary embodiment depicted in FIG. **5**, exemplary transducer **500** can be configured as an acoustic array **502** to facilitate phase focusing. That is, transducer **500** can be configured as an array of electronic apertures that may be operated by a variety of phases via variable electronic time delays. By the term “operated,” the electronic apertures of transducer **500** may be manipulated, driven, used, and/or configured to produce and/or deliver an energy beam corresponding to the phase variation caused by the electronic time delay. For example, these phase variations can be used to deliver defocused beams **508**, planar beams **504**, and/or focused beams **506**, each of which may be used in combination to achieve different physiological effects in ROI **210**. Transducer **500** may additionally comprise any software and/or other hardware for generating, producing and or driving a phased aperture array with one or more electronic time delays.

Transducer **500** can also be configured to provide focused treatment to one or more regions of interest using various frequencies. In order to provide focused treatment, transducer **500** can be configured with one or more variable depth devices to facilitate treatment. For example, transducer **500** may be configured with variable depth devices disclosed in commonly assigned U.S. patent application Ser. No. 10/944,500, entitled “System and Method for Variable Depth Ultrasound”, filed on Sep. 16, 2004, published on Mar. 16, 2006, as U.S. Patent Application Publication No. 20060058664, and incorporated herein by reference. In some embodiments, transducer probe **104** or transducer probe **400** can comprise transducer **500**.

In addition, transducer **500** can also be configured to treat one or more additional ROI **210** through the enabling of sub-harmonics or pulse-echo imaging, as disclosed in commonly assigned U.S. patent application Ser. No. 10/944,499, entitled “Method and System for Ultrasound Treatment with

a Multi-directional Transducer”, filed on Sep. 16, 2004, published on Mar. 16, 2006 as U.S. Patent Application Publication No. 20060058707, and incorporated herein by reference.

Moreover, any variety of mechanical lenses or variable focus lenses, e.g. liquid-filled lenses, may also be used to focus and/or defocus the sound field. For example, with reference to exemplary embodiments depicted in FIGS. **6A** and **6B**, transducer **600** may also be configured with an electronic focusing array **604** in combination with one or more transduction elements **606** to facilitate increased flexibility in treating ROI **210**. Array **604** may be configured in a manner similar to transducer **502**. That is, array **604** can be configured as an array of electronic apertures that may be operated by a variety of phases via variable electronic time delays, for example, $T_1, T_2 \dots T_j$. By the term “operated,” the electronic apertures of array **604** may be manipulated, driven, used, and/or configured to produce and/or deliver energy in a manner corresponding to the phase variation caused by the electronic time delay. For example, these phase variations can be used to deliver defocused beams, planar beams, and/or focused beams, each of which may be used in combination to achieve different physiological effects in ROI **210**.

Transduction elements **606** may be configured to be concave, convex, and/or planar. For example, in an exemplary embodiment depicted in FIG. **6A**, transduction elements **606** are configured to be concave in order to provide focused energy for treatment of ROI **210**. Additional embodiments of transducer **600** are disclosed in U.S. patent applications and U.S. patents that have been incorporated by reference herein.

In another exemplary embodiment, depicted in FIG. **6B**, transduction elements **606** can be configured to be substantially flat in order to provide substantially uniform energy to ROI **210**. While FIGS. **6A** and **6B** depict exemplary embodiments with transduction elements **604** configured as concave and substantially flat, respectively, transduction elements **604** can be configured to be concave, convex, and/or substantially flat. In addition, transduction elements **604** can be configured to be any combination of concave, convex, and/or substantially flat structures. For example, a first transduction element can be configured to be concave, while a second transduction element can be configured to be substantially flat. In some embodiments, transducer probe **104** or transducer probe **400** can comprise transducer **600**.

To further illustrate the various structures for transducer **404**, with reference to FIG. **7**, ultrasound therapy transducer **700** can be configured for a single focus, an array of foci, a locus of foci, a line focus, and/or diffraction patterns. Transducer **700** can also comprise single elements, multiple elements, annular arrays, one-, two-, or three-dimensional arrays, broadband transducers, and/or combinations thereof, with or without lenses, acoustic components, and mechanical and/or electronic focusing. Transducers configured as spherically focused single elements **702**, annular arrays **704**, annular arrays with damped regions **706**, line focused single elements **708**, 1-D linear arrays **710**, 1-D curvilinear arrays in concave or convex form, with or without elevation focusing, 2-D arrays, and 3-D spatial arrangements of transducers may be used to perform therapy and/or imaging and acoustic monitoring functions. For any transducer configuration, for example but not limited to including those employed in transducer probe **104** or transducer probe **400**, focusing and/or defocusing may be in one plane or two planes via mechanical focus **720**, convex lens **722**, concave lens **724**, compound or multiple lenses **726**, planar form **728**, or stepped form, such as illustrated in FIG. **10F**. Any transducer or combination of transducers may be utilized for treatment. For example, an annular transducer may be used with an outer portion dedi-

cated to therapy and the inner disk dedicated to broadband imaging wherein such imaging transducer and therapy transducer have different acoustic lenses and design, such as illustrated in FIGS. 10C-10F, as described below.

With reference to FIGS. 8A and 8B, transducer 404 can be configured as single-element arrays, wherein a single-element 802, e.g., a transduction element of various structures and materials, can be configured with a plurality of masks 804, such masks comprising ceramic, metal or any other material or structure for masking or altering energy distribution from element 802, creating an array of energy distributions 808. Masks 804 can be coupled directly to element 802 or separated by a standoff 806, such as any suitably solid or liquid material.

In accordance with another exemplary embodiment, transducer probe 104 or transducer probe 400 may be suitably diced in two dimensions to form a two-dimensional array. For example, with reference to FIG. 9, an exemplary two-dimensional array 900 can be suitably diced into a plurality of two-dimensional portions 902. Two-dimensional portions 902 can be suitably configured to focus on the treatment region at a certain depth, and thus provide respective slices 904, 907 of the treatment region. As a result, the two-dimensional array 900 can provide a two-dimensional slicing of image planes of a treatment region, thus providing two-dimensional treatment.

In accordance with another exemplary embodiment, transducer probe 400 may be suitably configured to provide three-dimensional treatment. For example, to provide three-dimensional treatment of ROI 210, with reference again to FIG. 3, a three-dimensional system can comprise transducer probe 104 or transducer probe 400 configured with an adaptive algorithm, such as, for example, one utilizing three-dimensional graphic software, contained in a control system, such as for example control system 300. The adaptive algorithm is suitably configured to receive two-dimensional imaging, temperature and/or treatment information relating to ROI 210, process the received information, and then provide corresponding three-dimensional imaging, temperature and/or treatment information.

In accordance with an exemplary embodiment, with reference again to FIG. 9, an exemplary three-dimensional system can comprise a two-dimensional array 900 configured with an adaptive algorithm to suitably receive 904 slices from different image planes of the treatment region, process the received information, and then provide volumetric information 906, e.g., three-dimensional imaging, temperature and/or treatment information. Moreover, after processing the received information with the adaptive algorithm, the two-dimensional array 900 may suitably provide therapeutic heating to the volumetric region 906 as desired.

Alternatively, rather than utilizing an adaptive algorithm, such as three-dimensional software, to provide three-dimensional imaging and/or temperature information, an exemplary three-dimensional system can comprise a single transducer 404 configured within a probe arrangement to operate from various rotational and/or translational positions relative to a target region.

An exemplary transducer 404 can also be configured as an annular array to provide planar, focused and/or defocused acoustical energy. For example, with reference to FIGS. 10A and 10B, in accordance with an exemplary embodiment, an annular array 1000 can comprise a plurality of rings 1012, 1014, 1016 to N. Rings 1012, 1014, 1016 to N can be mechanically and electrically isolated into a set of individual elements, and can create planar, focused, or defocused waves. For example, such waves can be centered on-axis, such as by

methods of adjusting corresponding transmit and/or receive delays, $T_1, T_2, T_3, \dots, T_N$. An electronic focus can be suitably moved along various depth positions, and can enable variable strength or beam tightness, while an electronic defocus can have varying amounts of defocusing. In accordance with an exemplary embodiment, a lens and/or convex or concave shaped annular array 1000 can also be provided to aid focusing or defocusing such that at any time differential delays can be reduced. Movement of annular array 1000 in one, two or three-dimensions, or along any path, such as through use of probes and/or any conventional robotic arm mechanisms, may be implemented to scan and/or treat a volume or any corresponding space within ROI 210.

Transducer 404 can also be configured in other annular or non-array configurations for imaging/therapy functions. For example, with reference to FIGS. 10C-10F, a transducer can comprise an imaging element 1012 configured with therapy element(s) 1014. Elements 1012 and 1014 can comprise a single-transduction element, e.g., a combined imaging/transducer element, or separate elements, can be electrically isolated 1022 within the same transduction element or between separate imaging and therapy elements, and/or can comprise standoff 1024 or other matching layers, or any combination thereof. For example, with particular reference to FIG. 10F, a transducer can comprise an imaging element 1012 having a surface 1028 configured for focusing, defocusing or planar energy distribution, with therapy elements 1014 including a stepped-configuration lens configured for focusing, defocusing, or planar energy distribution.

Various shaped treatment lesions can be produced using the various acoustic lenses and designs in FIGS. 10A-10F. For example, mushroom-shaped lesions may be produced from a spherically-focused source, and/or planar lesions from a flat source. That is, as the application of ablative ultrasound energy continues, this causes thermal expansion to generate a growing lesion. Concave planar sources and arrays can produce a "V-shaped" or ellipsoidal lesion. Electronic arrays, such as a linear array, can produce defocused, planar, or focused acoustic beams that may be employed to form a wide variety of additional lesion shapes at various depths. An array may be employed alone or in conjunction with one or more planar or focused transducers. Such transducers and arrays in combination produce a very wide range of acoustic fields and their associated benefits. A fixed focus and/or variable focus lens or lenses may be used to further increase treatment flexibility. A convex-shaped lens, with acoustic velocity less than that of superficial tissue, may be utilized, such as a liquid-filled lens, gel-filled or solid gel lens, rubber or composite lens, with adequate power handling capacity; or a concave-shaped, low profile, lens may be utilized and composed of any material or composite with velocity greater than that of tissue. While the structure of transducer source and configuration can facilitate a particular shaped lesion as suggested above, such structures are not limited to those particular shapes as the other spatial parameters, as well as the temporal parameters, can facilitate additional shapes within any transducer structure and source.

In accordance with an exemplary embodiment, with additional reference to FIG. 11, acoustic coupling and cooling 1140 can be provided to acoustically couple energy and imaging signals from transducer probe 1104 to and from ROI 210, to provide thermal control at the probe to ROI 210 interface 1110, and to remove potential waste heat from the transducer probe at region 1144. Temperature monitoring can be provided at the coupling interface via thermal sensor 1146 to provide a mechanism of temperature measurement 1148 and control via control system 1106 and thermal control system

1142. Thermal control may consist of passive cooling such as via heat sinks or natural conduction and convection or via active cooling such as with peltier thermoelectric coolers, refrigerants, or fluid-based systems comprised of pump, fluid reservoir, bubble detection, flow sensor, flow channels/tubing **1144** and thermal control **1142**. In some embodiments, transducer probe **1104** can be equivalent to transducer probe **104** or transducer probe **400**.

In accordance with another exemplary embodiment, with reference to FIG. **12**, an exemplary treatment system **200** can be configured with and/or combined with various auxiliary systems to provide additional functions. For example, an exemplary treatment system **1200** for treating ROI **210** can comprise a control system **1206**, a probe **1204**, and a display **1208**. In some embodiments, probe **1204** can be equivalent to transducer probe **104** or transducer probe **400** or transducer probe **1104**. Treatment system **1200** further comprises an auxiliary imaging modality **1274** and/or auxiliary monitoring modality **1272** may be based upon at least one of photography and other visual optical methods, magnetic resonance imaging (MRI), computed tomography (CT), optical coherence tomography (OCT), electromagnetic, microwave, or radio frequency (RF) methods, positron emission tomography (PET), infrared, ultrasound, acoustic, or any other suitable method of visualization, localization, or monitoring of cellulite within ROI **210**, including imaging/monitoring enhancements. Such imaging/monitoring enhancement for ultrasound imaging via probe **1204** and control system **1206** could comprise M-mode, persistence, filtering, color, Doppler, and harmonic imaging among others; furthermore an ultrasound treatment system **1270**, as a primary source of treatment, may be combined with a secondary source of treatment **1276**, including radio frequency (RF), intense pulsed light (IPL), laser, infrared laser, microwave, or any other suitable energy source.

An ultrasound treatment system as described herein, as a primary source of treatment, may be combined with a secondary source of treatment configured to deliver secondary treatment energy. Secondary treatment energy includes, but is not limited to, radio frequency (RF) energy, microwave energy, infrared light, visible light, ultraviolet light, and any other suitable electromagnetic energy. Secondary treatment energy may be coherent (as in a laser), incoherent, scattered, pulsed, refracted, focused, defocused, and/or delivered in any other form suitable for achieving a bio-effect.

In an exemplary embodiment, ultrasound treatment is combined with blue light treatment. As used herein, "blue light" means electromagnetic energy having a wavelength from about 400 nanometers to about 440 nanometers. Blue light is applied to the skin. Blue light may be applied as a pretreatment before therapeutic ultrasound energy is applied. Blue light may also be applied concurrently with therapeutic ultrasound energy. Furthermore, blue light may be applied before, during, or after therapeutic ultrasound treatment, or during any combination thereof.

In accordance with an exemplary embodiment, blue light is applied to ROI **210** for a period between 5 seconds and 20 minutes. Blue light may be applied to ROI **210** for any suitable amount of time in order to achieve a desired bio-effect.

In another exemplary embodiment, ultrasound treatment is combined with red light treatment. As used herein, "red light" means electromagnetic energy having a wavelength from about 600 nanometers to about 1350 nanometers. Red light is applied to ROI **210**. Red light may be applied as a pretreatment before therapeutic ultrasound energy is applied. Red light may also be applied concurrently with therapeutic ultra-

sound energy. Furthermore, red light may be applied before, during, or after therapeutic ultrasound treatment, or during any combination thereof.

In accordance with an exemplary embodiment, red light is applied to the skin for a period between 5 seconds and 20 minutes. Red light may be applied to the skin for any suitable amount of time in order to achieve a desired bio-effect.

In accordance with an exemplary embodiment, secondary treatment energy can be delivered by the probe which contains an ultrasound energy source. In other exemplary embodiments, secondary treatment energy is delivered by a source external to the probe. Secondary treatment energy may be generated by a light emitting diode (LED), a laser, an incandescent bulb, a fluorescent tube, an antenna, an intense pulsed light source, or any other suitable electromagnetic energy generation mechanism.

In one exemplary embodiment, energy is delivered in relatively small ablative areas in order to minimize and/or prevent scar tissue from forming. That is, each ablative area of treatment can range from approximately 100 microns to 55 mm in diameter. In another exemplary embodiment, ultrasound energy is used in a "lawnmower" type fashion to evenly ablate a treatment region to provide a substantially planar surface of lobuli. This "lawnmower"-type ablation in turn, helps to achieve a substantially smooth surface of the epidermis.

With reference to FIG. **13**, another method of non-invasive treatment of cellulite is illustrated according to various other embodiments of the present invention. The cross-sectional diagram illustrates the layers of tissue below skin surface **1304** which is not to scale and is used for illustration purposes. Dermis layer **1302** includes skin surface **1304** and both the epidermis and dermis portions of the skin. Below the dermis layer **1302** is fat lobuli **1307**. Fat lobuli **1307** causes protrusions in skin surface **1304**, which gives skin surface **1304** a dimpled appearance **1311** or cellulite. Below fat lobuli **1307** is fascia layer **1315**, subcutaneous fat layer **1317** and then muscle layer **1319**.

In various aspects, probe **202** is coupled to skin surface **1304** and emits ultrasound energy to create conformal lesion **209** at specific depth **1305**. Conformal lesion **209** ablates a portion of fat lobuli **1307**. Probe movement **1303** along skin surface **1304** allows for ablation of a plurality of fat lobuli **1307** at specific depth **1305**. This may be described as a lawnmower type ablation or a haircut of fat lobuli **1307**. Probe movement **1303** leaves behind smoothed skin **1309**. The treatment may need to be repeated in order to achieve a desired degree of smoothed skin **1309**. This method may be combined with any other method steps described herein such as for example applying a physical treatment or applying a secondary energy source.

In accordance with an exemplary embodiment of the present invention, a method of non-invasive treatment of cellulite includes targeting ROI **210** below skin surface **1304**, which contains fat lobuli **1307**, and delivering ultrasound energy at specified depth **1305** below skin surface **1304**. The method further includes moving a source of the energy along skin surface **1304** and ablating a portion of fat lobuli **1307** at specified depth **1305** below skin surface **1304**.

Specified depth **1305** is generally in the range of about 1 mm to about 35 mm below skin surface **1304**. The method can include applying a physical treatment as described herein. The method can smooth skin surface **1304** and may reduce the appearance of cellulite on skin surface **1304**. The method can further include any of the additional method steps discussed herein.

With reference to FIG. **14**, a method of non-invasive treatment of cellulite is illustrated according to another exemplary

embodiment of the present invention. The cross-sectional diagram illustrates the layers of tissue below skin surface 1304 which is not to scale and is used for illustration purposes. Dermis layer 1302 includes skin surface 1304 and both the epidermis and dermis portions of the skin. Below dermis layer 1302 is fat lobuli 1307. Fat lobuli 1307 causes protrusions in skin surface 1304, which gives skin surface 1304 a dimpled appearance 1311 or cellulite. Below fat lobuli 1307 is fascia layer 1315, subcutaneous fat layer 1317 and then muscle layer 1319.

In the exemplary embodiment illustrated in FIG. 14A, probe 202 is coupled to skin surface 1304 and emits ultrasound energy to create conformal lesion 209 in the surface of fat lobuli 1307 to create opening 1321. A material that is housed in the punctured fat lobuli 1317 flows out of opening 1321. This material can be a fluid, a lipid, a lymphatic substance, fat, tissue, bodily materials, or any other material and mixtures thereof. The material can be any tissue, fluid, or the like that is typically housed in fat lobuli 1317. Moving to FIG. 14B, reduced fat lobuli 1325 has shriveled due to the loss of the material. The shrinking of reduced fat lobuli 1325 can cause smoothed skin 1309 above reduced fat lobuli 1325 which has been drained of the material, thereby reducing the appearance of cellulite on skin surface 1304.

In accordance with another exemplary embodiment, a method of non-invasive treatment of cellulite includes targeting ROI 210 below skin surface 1304, which contains fat lobuli 1307 and delivering ultrasound energy to ROI 210. The ultrasound energy generates conformal lesion 209 with the ultrasound energy on a surface of fat lobuli 1307. The lesion creates opening 1321 in the surface of fat lobuli 1307, which allows the draining of a fluid out of fat lobuli 1307 and through opening 1321.

The method can further include heating ROI 210 to a temperature in a range from about 43° C. to about 49° C., which can stimulate apoptosis of at least one fat cell in fat lobuli 1307. Still further the method can include applying a physical treatment to skin surface 1304 and such physical treatment can include mesotherapy, Iontophoresis, pressotherapy, pneumatic massage, lymphatic drainage, electrolipophoresis, roller massage, low frequency ultrasound, vacuum suction, laser energy, and/or an application of RF energy. The physical treatment can be before, after, or concurrent with the delivery of the ultrasound energy. The method can include the use of a second energy, which can be used before, after, or concurrent with the delivery of the ultrasound energy. The method can reduce the appearance of cellulite on skin surface 1304.

With additional reference to FIG. 15, a block diagram illustrates an exemplary method for non-invasive treatment of cellulite according to various embodiments of the present invention. For example, method 1500 is a non-invasive treatment of cellulite. In step 1502, fat lobuli 1307 is targeted. Imaging the fat lobuli in a step 1503 may be useful in the targeting of fat lobuli 1307 but is optional or otherwise not required.

Targeting step 1502 is followed by energy delivery step 1504 which delivers ultrasound energy to form a conformal lesion 209 in the target which can be for example fat lobuli 1307. The ultrasound energy can be in the range from about 750 kHz to about 20 MHz and may be more useful in the range from about 2 MHz to about 10 MHz. The power of the ultrasound energy may be in a range from about 1 W to about 50 W and may be more useful in the range from about 2 W to about 20 W. The duration of the ultrasound energy may be in the range from about 10 milliseconds to about 20 minutes, or even more if desired. Energy delivery step 1504 may include applying secondary energy step 1505, which is optional.

Applying a secondary energy step 1505 may be useful in heating the tissue around the target to an elevated temperature prior to or during delivery of ultrasound energy to the targeted region, and can comprise a variety of energy sources including those discussed previously herein.

Energy delivery step 1504 is followed by creating an opening in the target step 1506, which provides an opening 1321. In this step 1506, conformal lesion 209 creates opening 1321 in the target. Upon creating an opening in the target, step 1506 is followed by a release of contents step 1508, in which at least a portion of the contents of fat lobuli 1307 are released through opening 1321, e.g., by draining. An application of secondary energy step 1505 may be applied after the creation of opening 1321 but is optional. Such application of secondary energy step 1505 may be useful in smoothing skin surface 1304 and/or in facilitating movement of at least a portion of the contents of fat lobuli 1307 to facilitate their release. The contents of fat lobuli 1307 can be a fluid, a lipid, a lymphatic substance, fat, tissue, bodily materials, or any other material and mixtures thereof. An application of physical treatment step 1507, such as, for example, by applying physical pressure or force to facilitate movement, may be useful in facilitating the releasing of at least a portion of the contents of fat lobuli 1307 through opening 1321, but this step 1507 is optional. An optional imaging step 1509 can be added for reviewing if the treatment was successful. If the treatment complete decision 1511 is yes, then the result is the final step 1510 wherein the skin is smoothed. If the treatment complete decision 1511 is no, then move to step 1504 for further treatment of the target until the treatment is successful within the treatment area, resulting in the smoothing of skin step 1510 which reduces the appearance of cellulite on skin surface 1304.

In accordance with another exemplary embodiment, a method of non-invasive treatment of cellulite includes identifying fat lobuli 1307 and creating a sharp focal of ultrasound energy onto fat lobuli 1307. The focal of energy pierces fat lobuli 1307 to create opening 1321, which then allows the flowing of a material out of fat lobuli 1307 through opening 1321. The method can further include any of the additional method steps discussed herein.

Now referring to FIG. 16, a method of non-invasive treatment for a reduction of fat is illustrated according to another exemplary embodiment of the present invention. In various embodiments, this method can be used as a non-invasive treatment of cellulite. The cross-sectional diagram illustrates the layers of tissue below skin surface 1304 which is not to scale and is used for illustration purposes. Dermis layer 1302 includes skin surface 1304 and both the epidermis and dermis portions of the skin. Below dermis layer 1302 is fat lobuli 1307. Fat lobuli 1307 causes protrusions in skin surface 1304, which gives skin surface 1304 a dimpled appearance 1311 or cellulite. Below fat lobuli 1307 is fascia layer 1315, subcutaneous fat layer 1317 and then muscle layer 1319.

In an exemplary embodiment, as illustrated in FIG. 16A, probe 202 is coupled to skin surface 1304 and emits ultrasound energy into adipose target area 1331. Adipose target area 1331 can include a portion of fat lobuli 1307. Adipose target area 1331 can include ROI 210. Fat lobuli 1307 can contain a plurality of adipose cells and a portion of the plurality of adipose cells can be located in adipose target area 1331. Adipose target area 1331 can include a plurality of other adipose cells 1329 that may be amongst fat lobuli 1307.

Probe 202 is targeted to deliver energy in adipose target area 1331. Adipose target area 1331 can be from about 1 mm to about 100 mm or greater below skin surface 1304. Height 1333 of adipose target area 1331 can be from about 1 mm to

about 10 mm or greater. Probe 202 delivers energy to create at least one conformal lesion 209 in adipose target area 1331. Delivered energy raises a temperature of at least a portion of adipose cells in fat lobuli 1307 and/or other adipose cells 1329 located in adipose target area 1331 to a range from about 43° C. to about 49° C., which stimulates apoptosis of fat cells, which can include at least a portion of other adipose cells in fat lobuli 1307 and/or other adipose cells 1329.

As illustrated in FIG. 16B, over a period of time, the portion of the plurality of adipose cells fat lobuli 1307 that were located in adipose target zone 1331 begin cell apoptosis. As these adipose cells die, fat lobuli 1307 shrinks. This cell apoptosis of the adipose cells reduces the amount of fat in an area on a patient. The effect of the reduction in size of fat lobuli 1307 by the adipose cell apoptosis can create smoothed skin 1309. In addition, other adipose cells 1329 that were located in adipose target area 1331 can begin cell apoptosis. As these other adipose cells 1329 die, skin surface 1304 can relax, which can contribute to creating smoothed skin 1309. Probe 202 can be moved along skin surface 1304 to enlarge the treatment of adipose target area 1331 of a patient's body.

An exemplary method, such as that illustrated by FIG. 16, can include applying a physical treatment to skin surface 1304, and such physical treatment can include mesotherapy, Iontophoresis, pressotherapy, pneumatic massage, lymphatic drainage, electrolipophoresis, roller massage, low frequency ultrasound, vacuum suction, laser energy, and application of RF energy. The physical treatment can be before, after, or concurrent with the delivery of the energy. The method can include the use of a second energy, which can be used before, after, or concurrent with the delivery of the energy.

With reference to FIG. 17, a block diagram illustrates a method 1600 of fat reduction according to an exemplary embodiment. For example, the method 1600 begins with step 1602 which is the targeting of a group of fat cells in adipose target area 1331. This targeting step 1602 may include the movement of probe 202 to include an enlarged target area. In targeting step 1602 a depth below skin surface 1304 that is appropriate for adipose target area 1331 is determined. Generally, a depth of greater than 1 mm but less than 100 mm is appropriate and this can vary from patient to patient depending on location on the body and level of patient's body fat.

Targeting step 1602 is followed by energy delivery step 1603 which is the delivering of ultrasound energy to the target fat cells. The ultrasound energy can be in the range from about 750 kHz to about 20 MHz and may be more useful in the range from about 2 MHz to about 10 MHz. The power of the ultrasound energy may be in a range from about 1 W to about 50 W and may be more useful in the range from about 2 W to about 20 W. The duration of the ultrasound energy may be in the range from about 10 milliseconds to about 20 minutes, or more if desired.

Energy delivery step 1603 is followed by raising temperature step 1604, which is the raising of the fat cell temperature from about 43.5° C. to about 49° C. Different combinations of parameters outlined in energy delivery step 1603 can be useful to raise the fat cell temperature to the desired range in step 1604. Raising temperature step 1604 creates or facilitates the stimulating apoptosis step 1605 which is the stimulating cell apoptosis of the fat cells in adipose target area 1331. If the fat cells are held in the desired temperature range for a sufficient amount of time, cell apoptosis will occur. Stimulating apoptosis step 1605 is followed by step 1606 which is the allowing of the targeted fat cells and/or targeted portions thereof to die. Upon allowing target portions to die in step 1606 results, a reduction of the total number of fat cells in adipose target area 1331 is achieved 1607. This reduction of the total number of

fat cells can result in lowering the circumference of a patient's body, for example the circumference of thighs, buttocks, hips, waist, and the like. In addition, this reduction of adipose target area 1331 can reduce an appearance of cellulite on skin surface 1304. Alternatively, or simultaneously, method 1600 can target fat cells in the subcutaneous fat layers to provide similar results.

Now with reference to FIGS. 18A and 18B, a method of non-invasive treatment for a reduction of fat is illustrated according to various exemplary embodiments of the present invention. In various embodiments, this method can be used as a non-invasive treatment of subcutaneous fat layer 1317. The cross-sectional diagram illustrates the layers of tissue below skin surface 1304 which is not to scale and is used for illustration purposes. The dermis layer 1302 includes skin surface 1304 and both the epidermis and dermis portions of the skin. Below dermis layer 1302 is fat lobuli 1307. Fat lobuli 1307 causes protrusions in skin surface 1304, which gives skin surface 1304 a dimpled appearance 1311 or cellulite. Below fat lobuli 1307 is fascia layer 1315, subcutaneous fat layer 1317 and then muscle layer 1319. Subcutaneous fat layer 1317 can have a selected depth 1337.

In an exemplary embodiment as illustrated in FIG. 18A, probe 202 is coupled to skin surface 1304 and emits ultrasound energy into adipose target area 1331. Adipose target area 1331 can include a portion of subcutaneous fat layer 1317. Subcutaneous fat layer 1317 can contain a plurality of adipose cells and a portion of the plurality of adipose cells can be located in adipose target area 1331.

Probe 202 is targeted to deliver energy in adipose target area 1331. Adipose target area 1331 can be from about 1 mm to about 100 mm or greater below the surface of the skin 1304. Height 1333 of adipose target area 1331 can be from about 1 mm to about 10 mm or greater. Probe 202 delivers energy to create at least one conformal lesion 209 which is located in adipose target area 1331. Delivered energy raises a temperature of at least a portion of the adipose cells located in adipose target area 1331 in to a range from about 43° C. to about 49° C., which stimulates apoptosis of the fat cells, which can include at least a portion of adipose cells in fat lobuli 1307 and/or other adipose cells 1399.

Over a period of time, the portion of the plurality of adipose cells in subcutaneous fat layer 1317 that were located in adipose target area 1331 begin cell apoptosis. As these adipose cells die, subcutaneous fat layer 1317 shrinks. This cell apoptosis of the adipose cells reduces the amount of fat in an area on a patient. As illustrated in FIG. 18B, the effect of the adipose cell apoptosis in subcutaneous fat layer 1317 can create smoothed skin 1309.

In addition, the effect of the adipose cell apoptosis in subcutaneous fat layer 1317 can create a reduction 1335 in the total volume of tissue in the treatment area. In accordance with the method, probe 202 can be moved along skin surface 1304 to enlarge the treatment of adipose target area 1331 of a patient's body. For example, this reduction 1335 can cause a decrease in the circumference of a patient's thighs, buttocks, hips, waist, and the like. As the adipose cell apoptosis in subcutaneous fat layer 1317 continues, skin surface 1304 can relax and can contribute to creating smoothed skin 1309. Subcutaneous fat layer 1317 can have a reduced depth 1339 after cell apoptosis. Reduced cell depth 1339 generally results from thickness of depth 1337 less the thickness 1333 of adipose target area 1331, i.e., the portion shrunk from cell apoptosis.

Various exemplary methods as illustrated in FIG. 18 provide a method of non-invasively stimulating apoptosis of a fat cell located in subcutaneous fat layer 1317. The method

includes targeting at least one fat cell in subcutaneous fat layer 1317 below skin surface 1304 and delivering energy to the fat cell. The delivered energy raises a temperature of the fat cell into a range from about 43° C. to about 49° C., which stimulates apoptosis of the fat cell.

The method can further include imaging of a fat cell or fat lobuli 1307. Still further, the method can include generating conformal lesion 209 into at least one fat cell, which can create opening 1321 in a fat cell or fat lobuli 1307 and allow the moving of a material out of a fat cell or fat lobuli 1307 and through opening 1321. This material can be a fluid, a lipid, a lymphatic substance, fat, tissue, bodily materials, or any other material and mixtures thereof. The ultrasound energy can be in the range from about 750 kHz to about 20 MHz and may be more useful in the range from about 2 MHz to about 10 MHz. The power of the ultrasound energy may be in a range from about 1 W to about 50 W and may be more useful in the range from about 2 W to about 20 W. The duration of the ultrasound energy may be in the range from about 10 milliseconds to about 20 minutes. Still further, the method can include applying a physical treatment to skin surface 1304 and such physical treatment can include mesotherapy, iontophoresis, pressotherapy, pneumatic massage, lymphatic drainage, electrolipophoresis, roller massage, low frequency ultrasound, vacuum suction, laser energy, and application of RF energy. The physical treatment can be before, after, or concurrent with the delivery of the energy. The method can include the use of a second energy, which can be used before, after, or concurrent with the delivery of the energy. The method can reduce the number of fat cells in subcutaneous fat layer 1317.

In addition, various other exemplary embodiments of the present invention can include a method that combines fat reduction and cellulite reduction. The method includes targeting ROI 210 below skin surface 1304, which contains fat lobuli 1307 and delivering ultrasound energy to ROI 210. The ultrasound energy generates conformal lesion 209 with said ultrasound energy on a surface of fat lobuli 1307. Conformal lesion 209 creates opening 1321 in the surface of fat lobuli 1307, which allows the draining of a fluid out of fat lobuli 1307 and through opening 1321. Additionally, the method can include targeting at least one fat cell in subcutaneous fat layer 1317 below skin surface 1304 and delivering a second energy to the fat cell. The delivered second energy raises a temperature of the fat cell into a range from about 43° C. to about 49° C., which stimulates apoptosis of the fat cell.

The method can further include a physical treatment as described herein, as well as the use of a secondary energy source. The method can both reduce the number of fat cells in subcutaneous fat layer 1317 and reduce the appearance of cellulite on skin surface 1304. The method can be effective in the physically breaking fat cell clusters and stretching fibrous bonds of cellulite.

In accordance with another exemplary embodiment of the present invention, a method of non-invasive treatment of cellulite includes identifying fat lobuli 1307 and creating a sharp focal of ultrasound energy onto fat lobuli 1307. The focal of energy pierces fat lobuli 1307 to create opening 1321, which then allows the flowing of a material out of fat lobuli 1307 through opening 1321. The method can further include any of the additional method steps discussed herein.

In various embodiments, the energy is delivered at a treatment depth from about 0 mm to about 50 mm or about 1 mm to about 35 mm. The ultrasound energy can be in the range from about 750 kHz to about 20 MHz and may be more useful in the range from about 2 MHz to about 10 MHz. The power of the ultrasound energy may be in a range from about 1 W to

about 50 W and may be more useful in the range from about 2 W to about 20 W. The duration of the ultrasound energy may be in the range from about 10 milliseconds to about 20 minutes.

Once the treatment protocol, for any of the methods of treatment discussed herein or variations thereof, has been implemented, ROI 210 may have one or more reactions to the treatment. For example, in some embodiments, the tissue responds by enhancement of lymphatic drainage, evacuation of fat decay products, creation of a thermal injury and/or coagulation of proximal protrusions of fat lobuli 1307.

In an exemplary embodiment, energy such as ultrasound energy is emitted from a treatment system at multiple depths to target numerous areas within a specific ROI 210. Multiple layers of tissue within ROI 210 are treated from the surface down to the deepest point of ultrasound energy penetration and no intervening layers of tissue are spared in one embodiment of the present invention. In addition to ultrasound energy, other energy forms such as laser energy, radio frequency energy, and other energies can be used and fall within the scope of the present invention. Further, blue light at a wavelength of approximately 400 to 450 nm can be used to pre-treat ROI 210 before the application of ultrasound energy or blue light of this wavelength can be used with ultrasound to increase the efficacy of treatment. In another embodiment, visible light in the range of 600 to 1350 nm can be used with the ultrasound during treatment.

Upon treatment, the steps outlined herein can be repeated one or more additional times to provide for optimal treatment results. Different ablation sizes and shapes of conformal lesion 209 may affect the recovery time and time between treatments. For example, in general, the larger the surface area of conformal lesion 209, the faster the recovery. The series of treatments can also enable the user to tailor additional treatments in response to a patient's responses to the ultrasound treatment.

The methods of treatment described herein can employ various shaped conformal lesions 209 and can be produced using the various acoustic lenses and designs described herein. For example, mushroom shaped lesions may be produced from a spherically-focused source, and/or planar lesions from a flat source. That is, as the application of ablative ultrasound energy continues, this causes thermal expansion to generate a growing lesion. Concave planar sources and arrays can produce a "V-shaped" or ellipsoidal lesion. Electronic arrays, such as a linear array, can produce defocused, planar, or focused acoustic beams that may be employed to form a wide variety of additional lesion shapes at various depths. Other lesion shapes that may be useful with the treatment methods described herein include the lesion shapes and patterns described in the U.S. patents and U.S. patent application that are incorporated by reference herein.

The citation of references herein does not constitute admission that those references are prior art or have relevance to the patentability of the invention disclosed herein. All references cited in the Description section of the specification are hereby incorporated by reference in their entirety for all purposes. In the event that one or more of the incorporated references differs from or contradicts this application, including, but not limited to, defined terms, term usage, described techniques, or the like, this application controls.

The present invention has been described above with reference to various exemplary embodiments. However, those skilled in the art will recognize that changes and modifications may be made to the exemplary embodiments without departing from the scope of the present invention. For example, the various operational steps, as well as the compo-

25

nents for carrying out the operational steps, may be implemented in alternate ways depending upon the particular application or in consideration of any number of cost functions associated with the operation of the system, e.g., various steps may be deleted, modified, or combined with other steps. These and other changes or modifications are intended to be included within the scope of the present invention, as set forth in the following claims.

What is claimed is:

1. An ultrasound treatment system for treatment of fat, the system comprising:

an ultrasound probe comprising a housing, a motion mechanism, and an ultrasound transducer,

wherein the ultrasound transducer comprises a therapy component and an imaging component,

wherein the therapy component consists of:

a single ultrasound therapy element,

wherein the single ultrasound therapy element delivers ultrasound energy at a frequency of between 2 MHz to 10 MHz,

wherein the single ultrasound therapy element is a single spherically focused element or a single cylindrically focused element,

wherein the single ultrasound therapy element is configured for delivery of energy at a temperature sufficient to coagulate at least a portion of a plurality of fat lobuli at a depth under a skin surface,

wherein the single ultrasound therapy element is connected to a portion of the motion mechanism,

wherein the imaging component comprises an ultrasound imaging element,

a control system comprising a processor and power supply; and

a display,

wherein a portion of the housing is configured for acoustic coupling to a skin surface,

wherein the ultrasound imaging element is in communication with the display,

wherein the ultrasound imaging element is configured for imaging a region of interest under the skin surface,

wherein the region of interest comprises a tissue, wherein the tissue comprises the plurality of fat lobuli at the depth under the skin surface,

wherein the display is configured to display an image of the region of interest,

wherein the single ultrasound therapy element is in communication with the control system,

wherein the motion mechanism is in communication with the control system,

wherein the motion mechanism moves the ultrasound therapy element to form a plurality of thermal foci at the depth for coagulating the at least a portion of the plurality of fat lobuli.

2. The system of claim 1, further comprising:

a user control switch to activate the single ultrasound therapy element,

wherein the ultrasound energy increases the speed at which fat metabolizes according to the Arrhenius Law: $Y=A \cdot e^{-B/T}$, where Y is the yield of metabolic reaction, A and B are constants, and T is the temperature in degrees Kelvin.

3. The system of claim 1, further comprising a monitoring system,

wherein the monitoring system is configured to monitor a treatment parameter, wherein the treatment parameter measured comprises a temperature of the tissue below the skin surface, and

26

wherein the housing further comprises a temperature monitoring sensor.

4. The system of claim 1,

wherein the motion mechanism comprises an encoder,

wherein the motion mechanism is a linear motion mechanism for linear movement of the single ultrasound therapy element within the ultrasound probe,

wherein the motion mechanism is configured to form a plurality of thermal lesions along a line at the depth in the region of interest by moving the single ultrasound therapy element.

5. The system of claim 1, further comprising an acoustic coupler between the ultrasound probe and the skin surface,

wherein the motion mechanism comprises an encoder, and wherein the motion mechanism is configured for any one of the group consisting of linear, rotational, and variable movement of the single ultrasound therapy element within the ultrasound probe.

6. The system of claim 1,

wherein the motion mechanism comprises an encoder for monitoring a position of the ultrasound therapy element on the motion mechanism in a housing of the probe,

wherein the ultrasound therapy element is configured to deliver the energy at the depth below the skin surface.

7. The system of claim 1, further comprising a monitoring system,

wherein the monitoring system is configured to monitor a treatment parameter, wherein the treatment parameter measured comprises a temperature of the tissue below the skin surface,

wherein the housing further comprises a temperature monitoring sensor,

wherein the therapy element is configured to increase a temperature of the tissue to a range of 43 to 49 degrees Celsius,

wherein the ultrasound energy is delivered with a treatment power of between 1 W and 50 W.

8. The system of claim 1, wherein the ultrasound imaging element and the single ultrasound therapy element are in a combined transducer, wherein the single therapy element is a single cylindrically focused element.

9. An ultrasound treatment system for treatment of fat, the system comprising:

an ultrasound probe comprising a housing, a motion mechanism, and an ultrasound transducer, wherein the ultrasound transducer comprises a therapy component, wherein the therapy component consists of:

a single cylindrically focused ultrasound therapy element,

wherein the single cylindrically focused ultrasound therapy element delivers ultrasound energy at a frequency of between 750 kHz to 20 MHz,

wherein the single cylindrically focused ultrasound therapy element is configured for delivery of energy at a temperature sufficient to coagulate at least a portion of a plurality of fat lobuli at a depth under a skin surface,

wherein a portion of the ultrasound probe is configured for acoustic coupling to a skin surface; and

a control system;

wherein the single cylindrically focused ultrasound therapy element is in communication with the control system,

wherein the motion mechanism is in communication with the control system,

27

wherein the single cylindrically focused ultrasound therapy element is connected to a portion of the motion mechanism,

wherein the motion mechanism moves the single cylindrically focused ultrasound therapy element to coagulate the at least the portion of the plurality of fat lobuli.

10. The system of claim 9,

wherein the housing further comprises an ultrasound imaging element,

wherein the ultrasound imaging element is configured for imaging a region of interest under the skin surface, wherein the region of interest comprises the plurality of fat lobuli.

11. The system of claim 9,

wherein the single cylindrically focused ultrasound therapy element delivers ultrasound energy at a frequency of between 2 MHz to 10 MHz, and

wherein the ultrasound energy increases the speed at which fat metabolizes according to the Arrhenius Law: $Y=A \cdot e^{-B/T}$, where Y is the yield of metabolic reaction, A and B are constants, and T is the temperature in degrees Kelvin.

12. The system of claim 9,

wherein the single cylindrically focused ultrasound therapy element is configured to deliver the energy up to 5.5 cm below the skin surface,

wherein the ultrasound energy is delivered with a treatment power of between 1 W and 50 W.

13. An ultrasound treatment system for treatment of fat, the system comprising:

an ultrasound probe comprising a housing, a motion mechanism, and an ultrasound transducer, wherein the ultrasound transducer comprises a therapy component and an imaging component,

wherein the therapy component consists of:

a single ultrasound therapy element,

wherein a portion of the ultrasound probe is configured for acoustic coupling to a skin surface;

a control system; and

a display;

wherein the imaging component comprises an ultrasound imaging element configured for imaging a region of interest under the skin surface, wherein the region of interest comprises a tissue, wherein the tissue comprises a plurality of fat lobuli,

wherein the display is configured to display an image of the region of interest,

wherein the single ultrasound therapy element is configured for delivery of energy to the region of interest under

28

the skin surface, wherein the single ultrasound therapy element is configured to coagulate at least a portion of the plurality of fat lobuli at a depth under the skin surface,

wherein the single ultrasound therapy element is connected to the motion mechanism,

wherein the motion mechanism moves the single ultrasound therapy element to form a plurality of thermal lesions at the at least the portion of the plurality of fat lobuli at the depth for reducing the appearance of fat.

14. The system of claim 13,

wherein the therapy element is a single element that delivers ultrasound energy at a frequency of between 2 MHz to 10 MHz,

wherein the ultrasound therapy element is configured to deliver the energy at the depth below the skin surface.

15. The system of claim 13, wherein the ultrasound energy is configured to deliver an energy level for heating at least the portion of the plurality of fat lobuli to a temperature in a range of 43 to 49 degrees Celsius.

16. The system of claim 13, further comprising a monitoring system,

wherein the monitoring system is configured to monitor a treatment parameter, wherein the treatment parameter measured comprises a temperature of the tissue below the skin surface,

wherein the housing further comprises a temperature monitoring sensor,

wherein the control system comprises a spatial control and a temporal control, the spatial control and the temporal control controlling the delivery of energy to heat the at least the portion of the plurality of fat lobuli at the depth under the skin surface.

17. The system of claim 13, further comprising a user control switch to activate the ultrasound therapy element and wherein the ultrasound energy increases the speed at which fat metabolizes according to the Arrhenius Law: $Y=A \cdot e^{-B/T}$, where Y is the yield of metabolic reaction, A and B are constants, and T is the temperature in degrees Kelvin.

18. The system of claim 13, wherein the control system comprises: an input device; a power supply; and a communication device.

19. The system of claim 13, wherein the therapy element is a spherically focused single element.

20. The system of claim 13, wherein the therapy element is a cylindrically focused single element.

* * * * *

专利名称(译)	基于能量的脂肪减少		
公开(公告)号	US9283409	公开(公告)日	2016-03-15
申请号	US14/550772	申请日	2014-11-21
申请(专利权)人(译)	引导治疗系统公司		
当前申请(专利权)人(译)	引导治疗系统公司		
[标]发明人	SLAYTON MICHAEL H BARTHE PETER G		
发明人	SLAYTON, MICHAEL H. BARTHE, PETER G.		
IPC分类号	A61B8/00 A61N7/00 A61B5/00 A61N7/02 B06B1/06 G01S7/52 G01S15/89 A61B8/08 A61B8/14		
CPC分类号	A61N7/00 A61B5/4869 A61B8/429 A61B8/4483 A61B8/483 A61N7/02 B06B1/0622 G01S7/5208 G01S15/8906 G01S15/899 G01S15/8993 A61N2007/0052 A61B8/0858 A61B8/14 A61B8/4455 A61B2090/378 A61N2007/0008 A61N2007/027 B06B1/0607 H05K999/99		
优先权	12/646609 2014-03-04 US 11/163154 2012-03-13 US 60/616753 2004-10-06 US 61/140725 2008-12-24 US		
其他公开文献	US20150088182A1		
外部链接	Espacenet USPTO		

摘要(译)

用于非侵入性脂肪减少的方法可包括将目标区域靶向皮肤表面下方，所述皮肤表面含有脂肪并将超声能量传递到感兴趣的区域。超声能量在脂肪细胞上产生具有所述超声能量的热损伤。病变可在脂肪细胞的表面形成开口，这允许流体从脂肪细胞排出并通过开口。另外，通过向脂肪细胞施加超声能量以将温度升高到43度和49度之间，可以实现细胞凋亡，从而导致脂肪减少。

