



US 20180103893A1

(19) **United States**

(12) **Patent Application Publication**
FLEMING et al.

(10) **Pub. No.: US 2018/0103893 A1**
(43) **Pub. Date: Apr. 19, 2018**

(54) **REMOTE DELIVERY AND MONITORING OF HEALTH CARE**

(52) **U.S. Cl.**
CPC *A61B 5/445* (2013.01); *A61B 2560/0456* (2013.01); *G16H 40/67* (2018.01); *A61B 5/0013* (2013.01); *A61B 5/0022* (2013.01); *A61B 5/0059* (2013.01); *A61B 5/6812* (2013.01); *A61B 5/74* (2013.01); *A61B 5/7207* (2013.01); *A61B 2090/378* (2016.02); *A61B 10/0045* (2013.01); *A61B 2560/0214* (2013.01); *A61B 2560/0431* (2013.01); *A61B 2090/376* (2016.02); *A61B 2560/0475* (2013.01); *A61B 5/7445* (2013.01)

(71) Applicant: **INTERNATIONAL BUSINESS MACHINES CORPORATION**, Armonk, NY (US)

(72) Inventors: **Mark FLEMING**, Oro Valley, AZ (US); **Christina LARA**, Tucson, AZ (US); **Michael P. COPELAND**, Vail, AZ (US); **Calline K. SANCHEZ**, Tucson, AZ (US)

(73) Assignee: **INTERNATIONAL BUSINESS MACHINES CORPORATION**, Armonk, NY (US)

(21) Appl. No.: **15/844,975**

(22) Filed: **Dec. 18, 2017**

Related U.S. Application Data

(63) Continuation of application No. 12/409,779, filed on Mar. 24, 2009, now Pat. No. 9,844,333.

Publication Classification

(51) **Int. Cl.**
A61B 5/00 (2006.01)
A61B 10/00 (2006.01)

(57) **ABSTRACT**

An automated medical apparatus for providing medical care in remote areas to a patient is provided. The apparatus includes a container having corrugated steel enclosure on all sides and transportable using a standardized commercial shipping mechanism, the container having a door with a handle and lock mechanism for secure entry and secure accommodation of the patient for treatment. The container has integrated into an inner ceiling side of the container, a plurality of automated dispensers, the dispensers configured for dispensing sterilization material upon determining by the apparatus that the door has been opened and closed, a first time and a second time respectively, such that the patient is assumed to have completed the treatment and exited the container. Further, the apparatus includes a power management device, a processor, a medical device interface, and a patient interface.

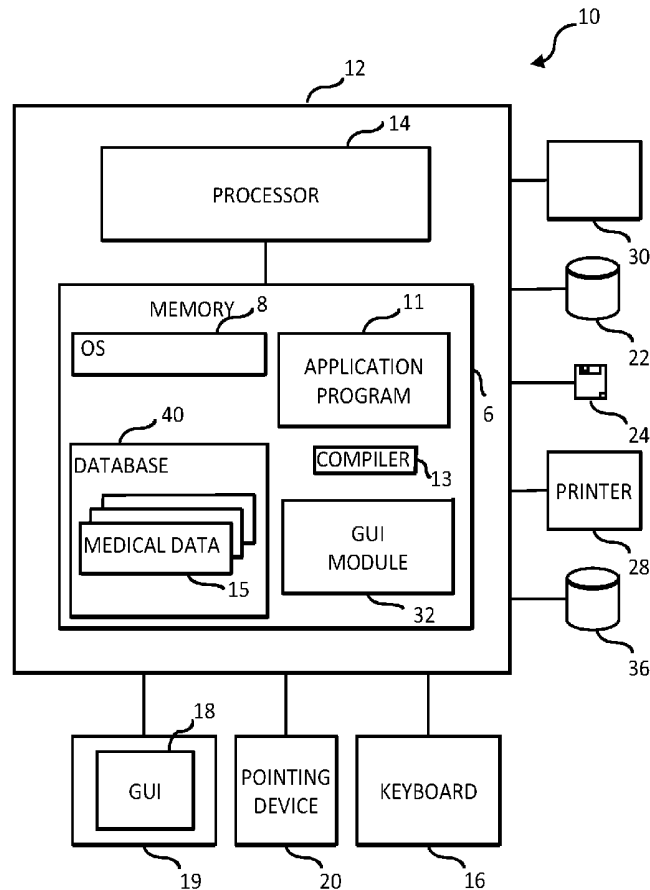

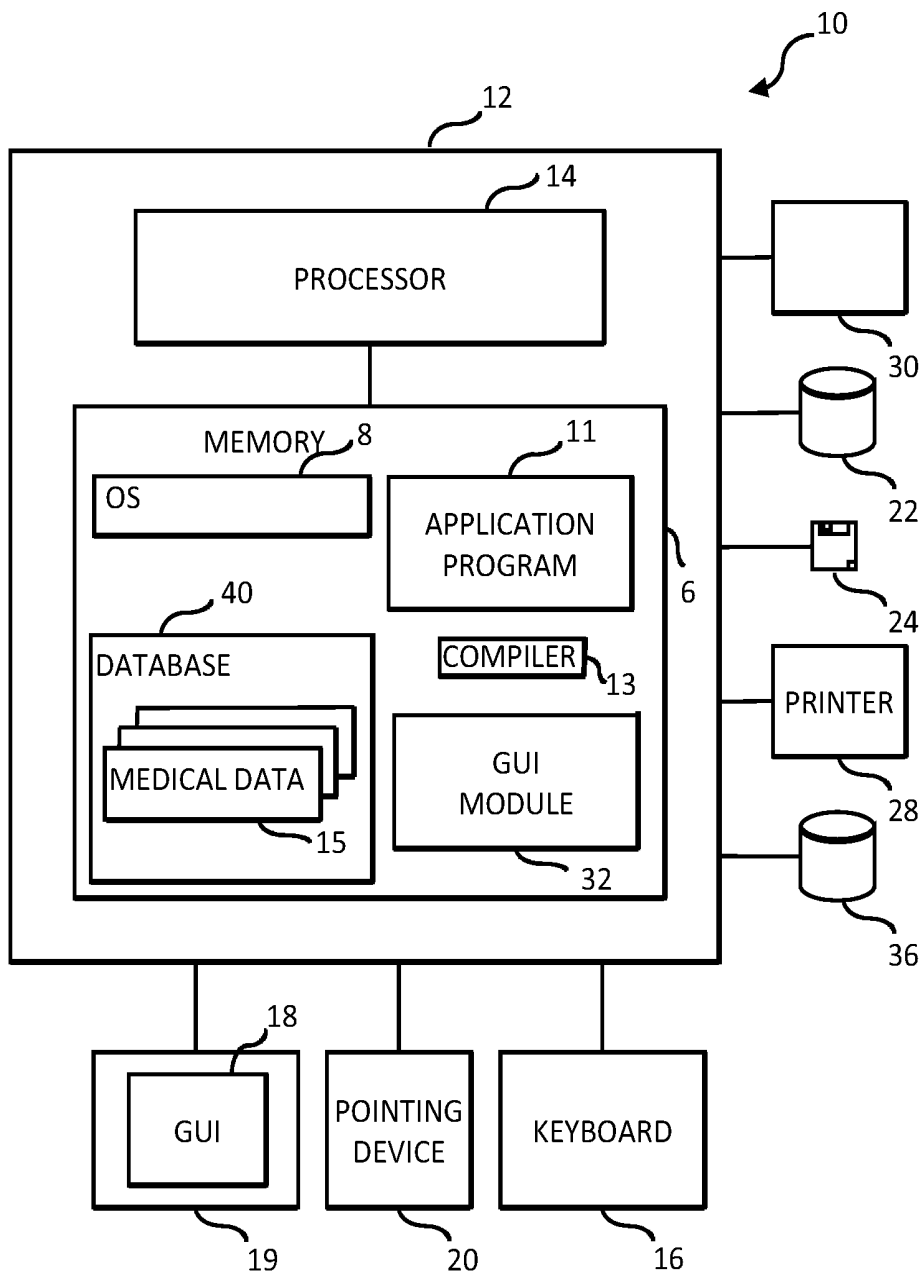

FIG. 1

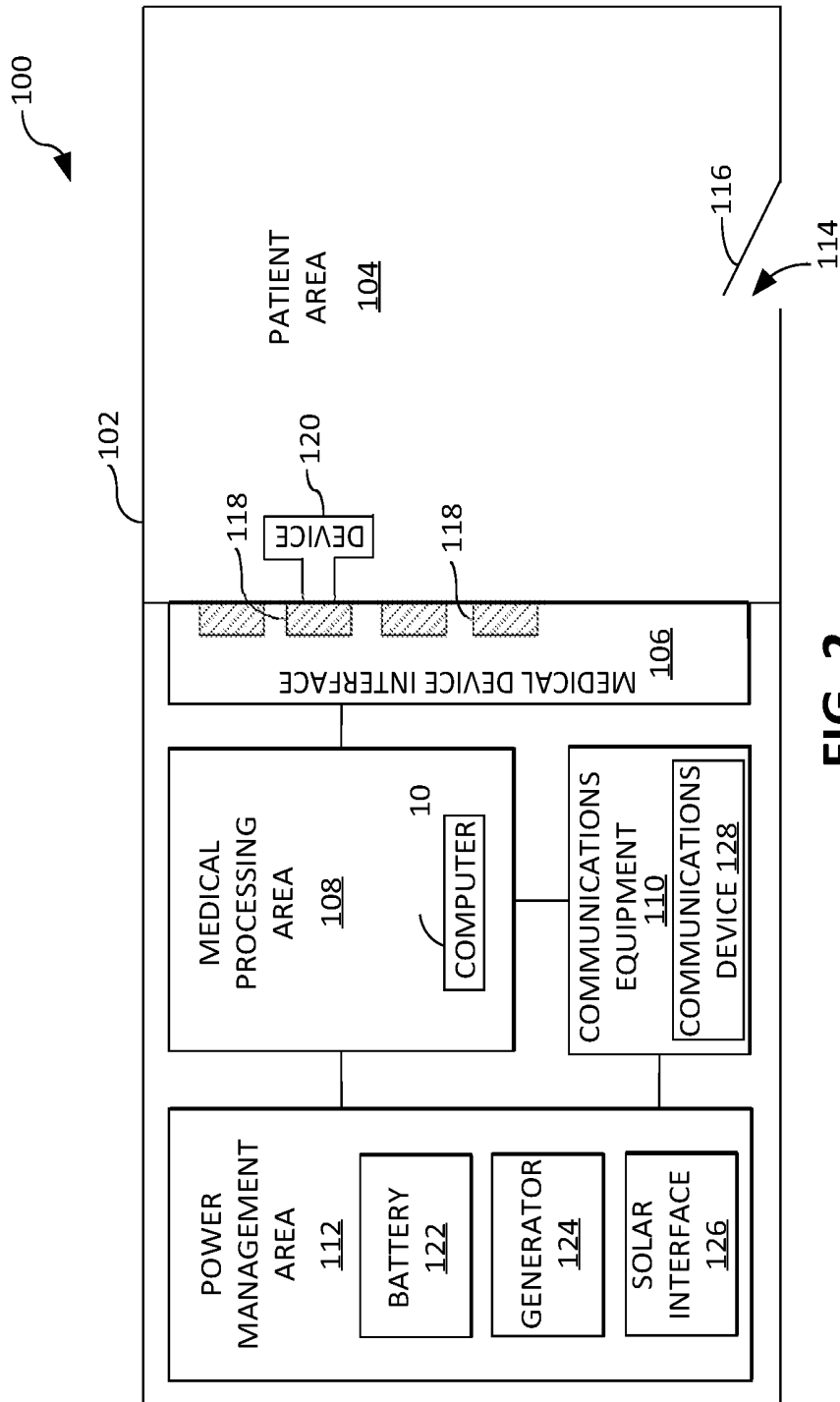

FIG. 2

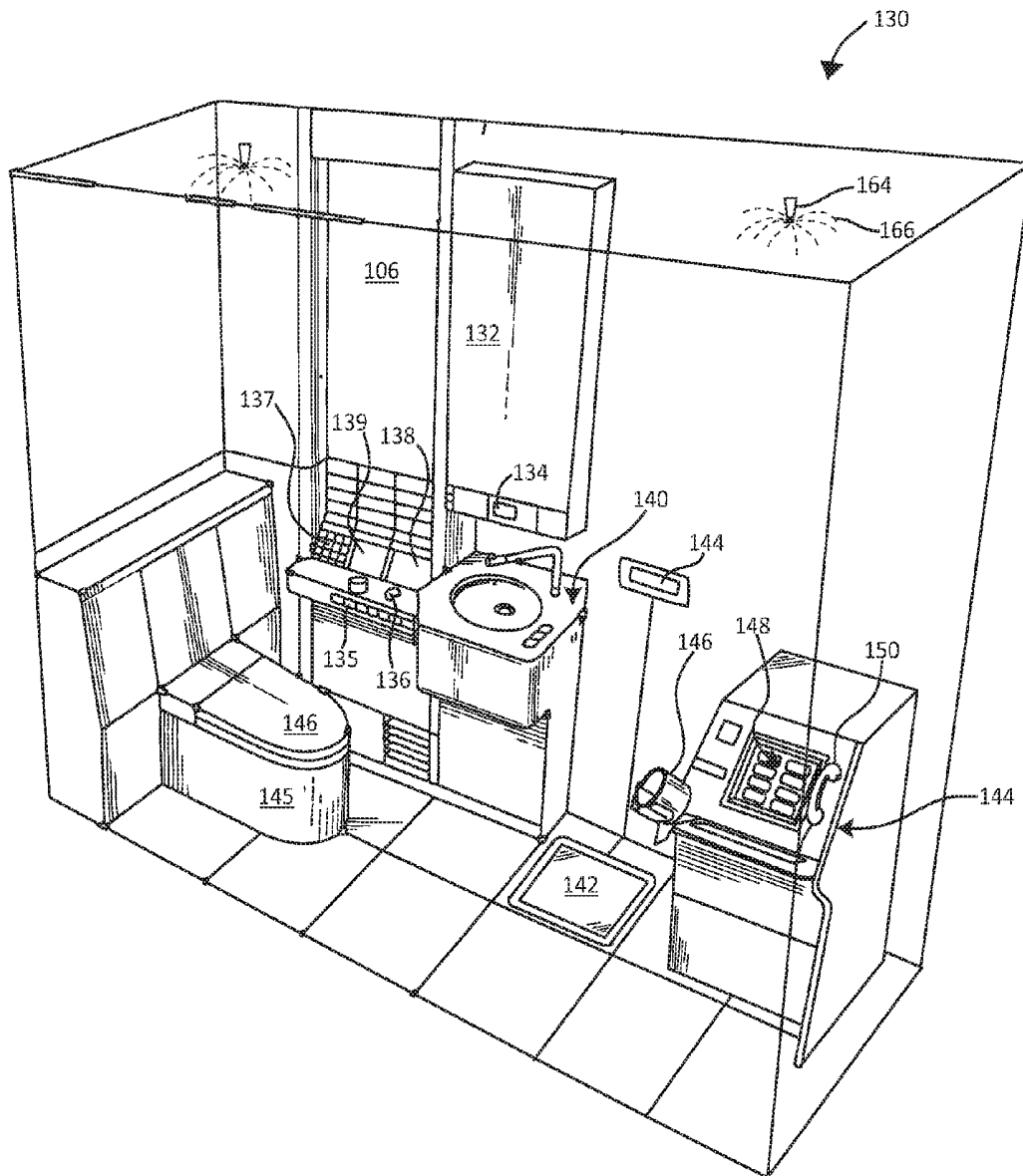

FIG. 3

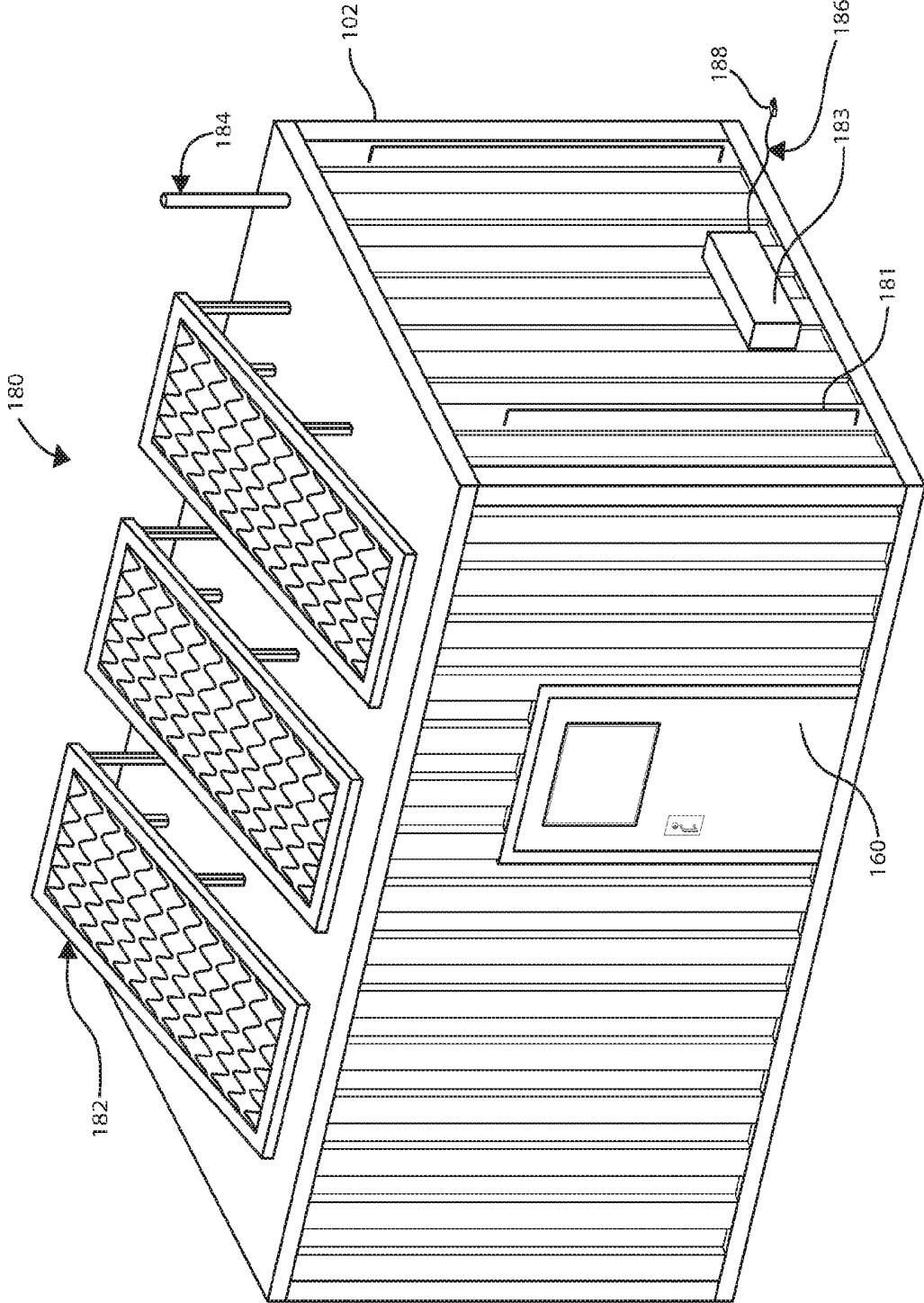

FIG. 4

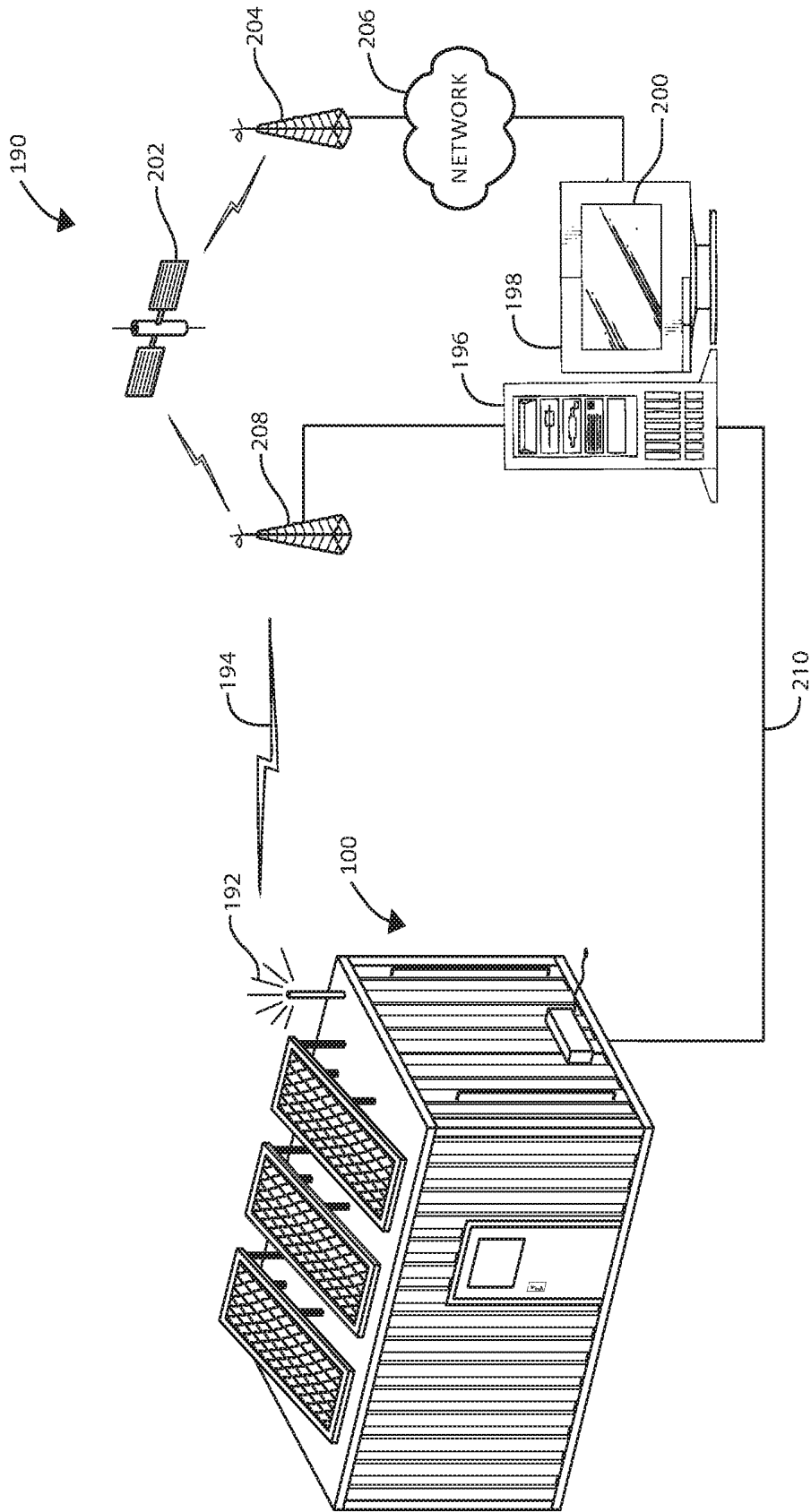

FIG. 5

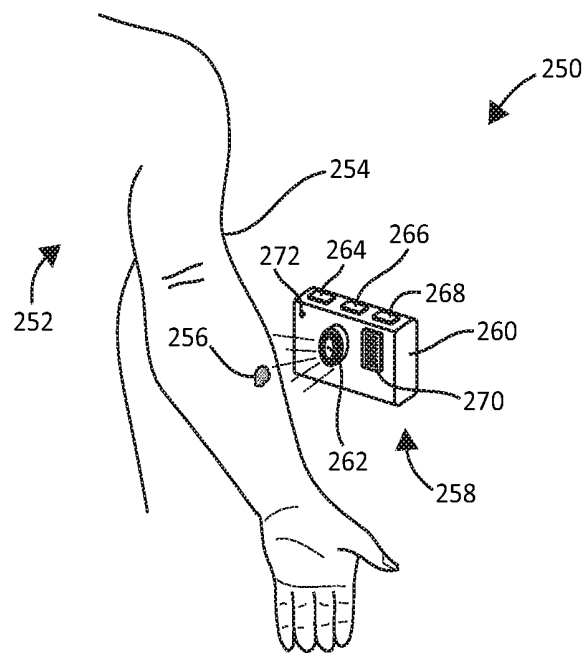

FIG. 6

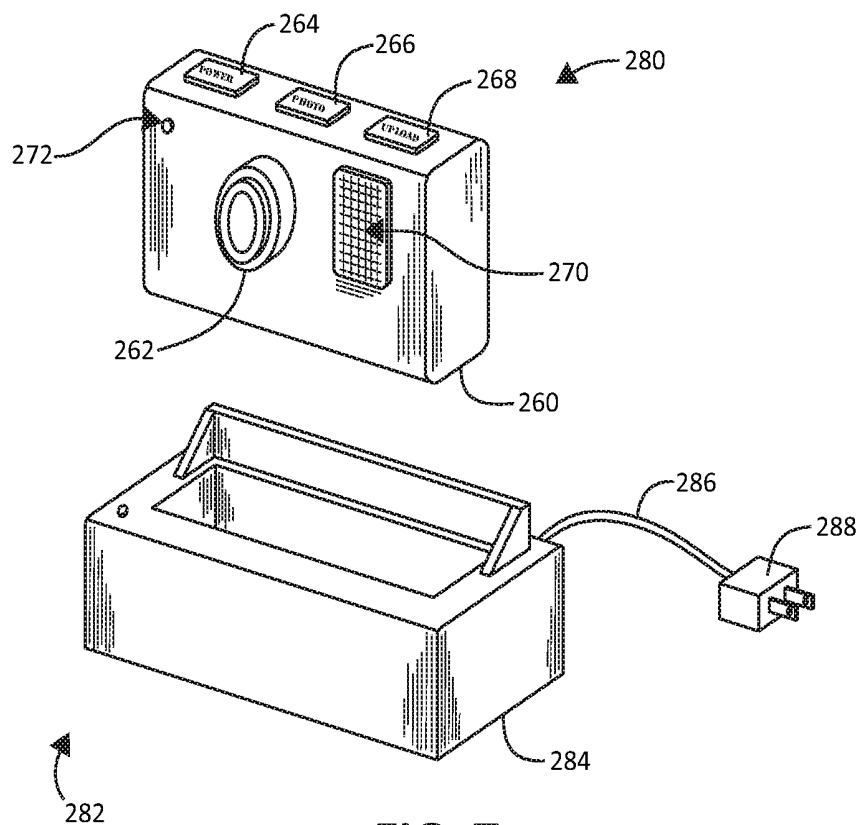

FIG. 7

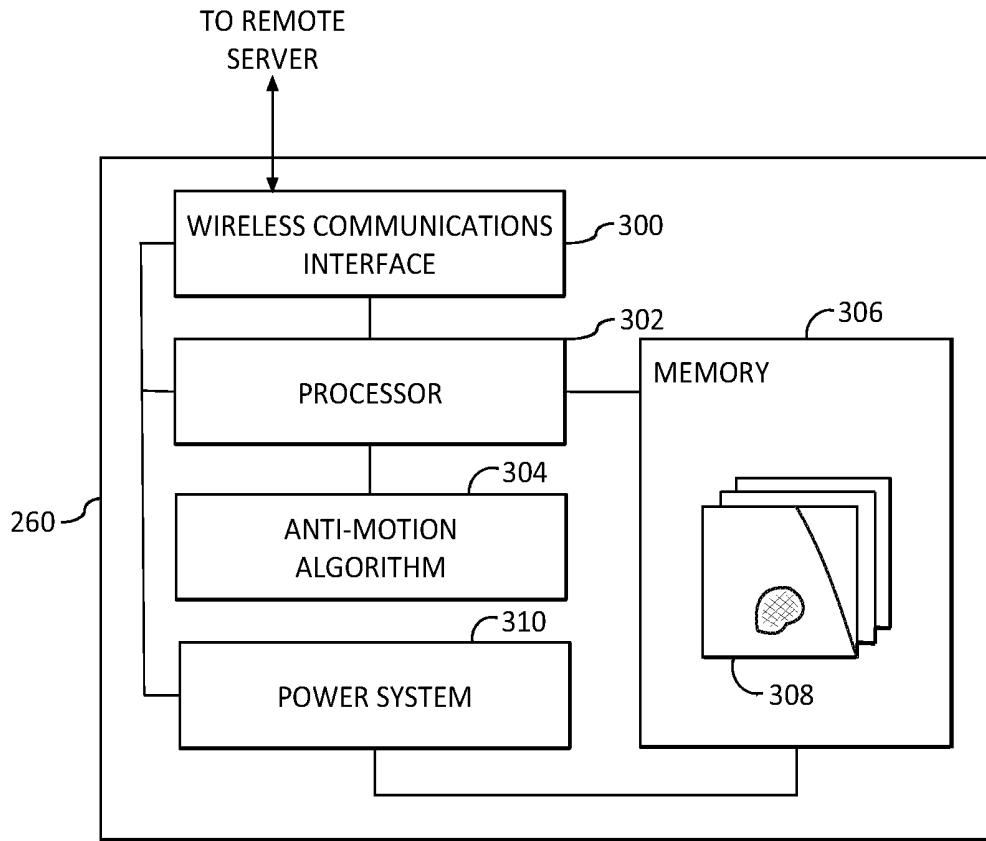

FIG. 8

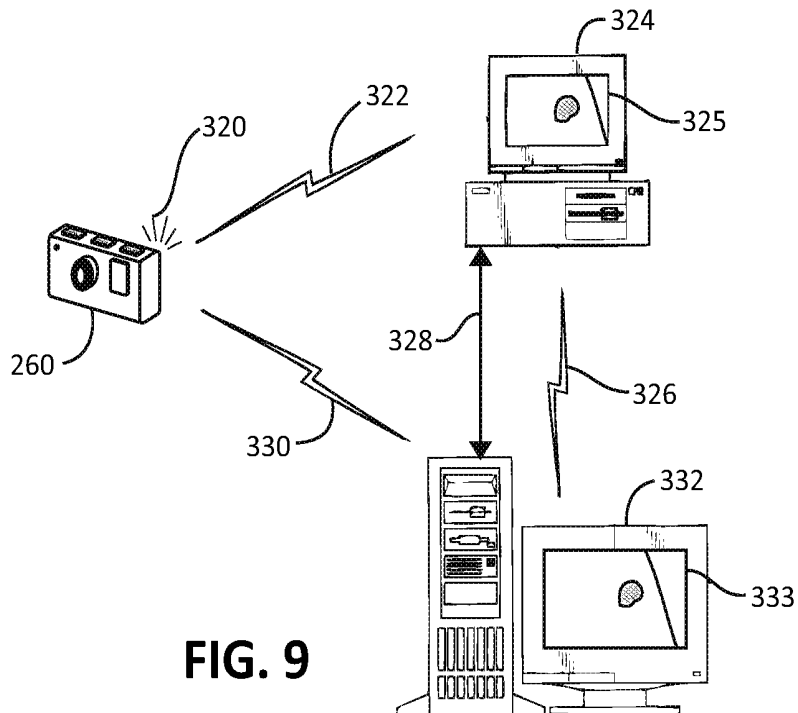

FIG. 9

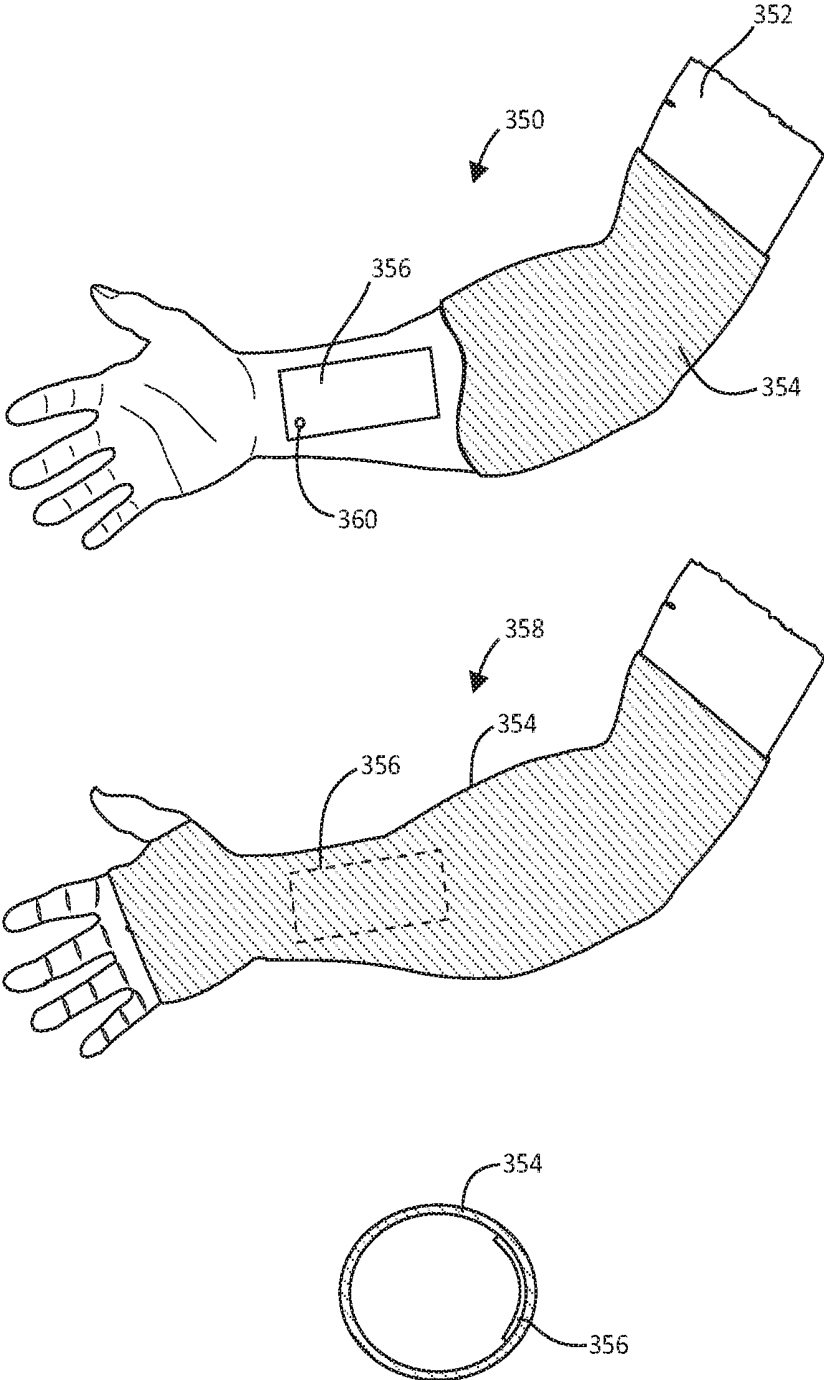

FIG. 10

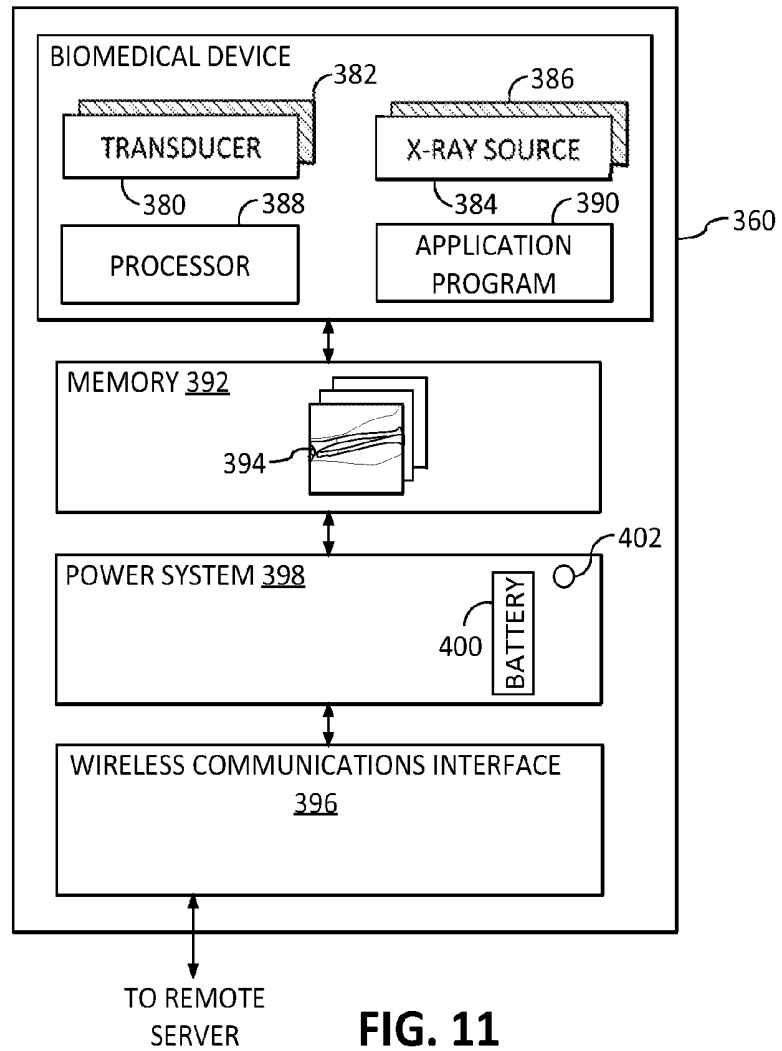

FIG. 11

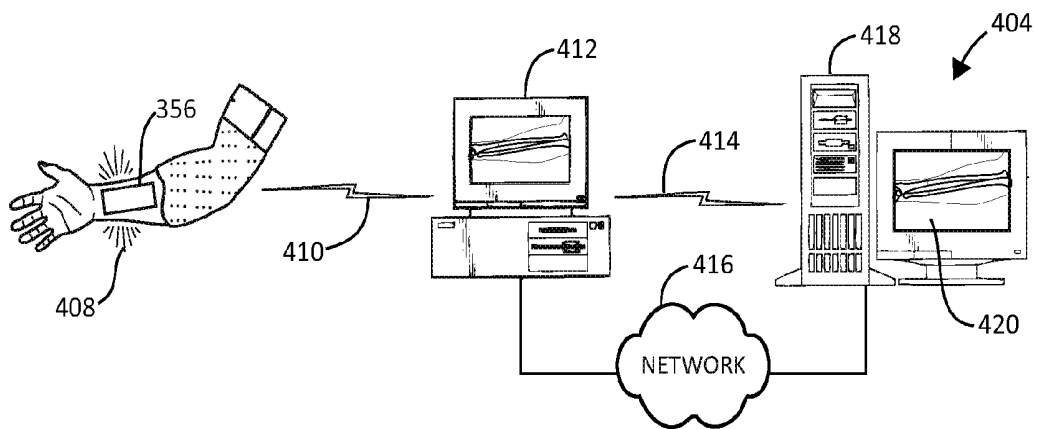

FIG. 12

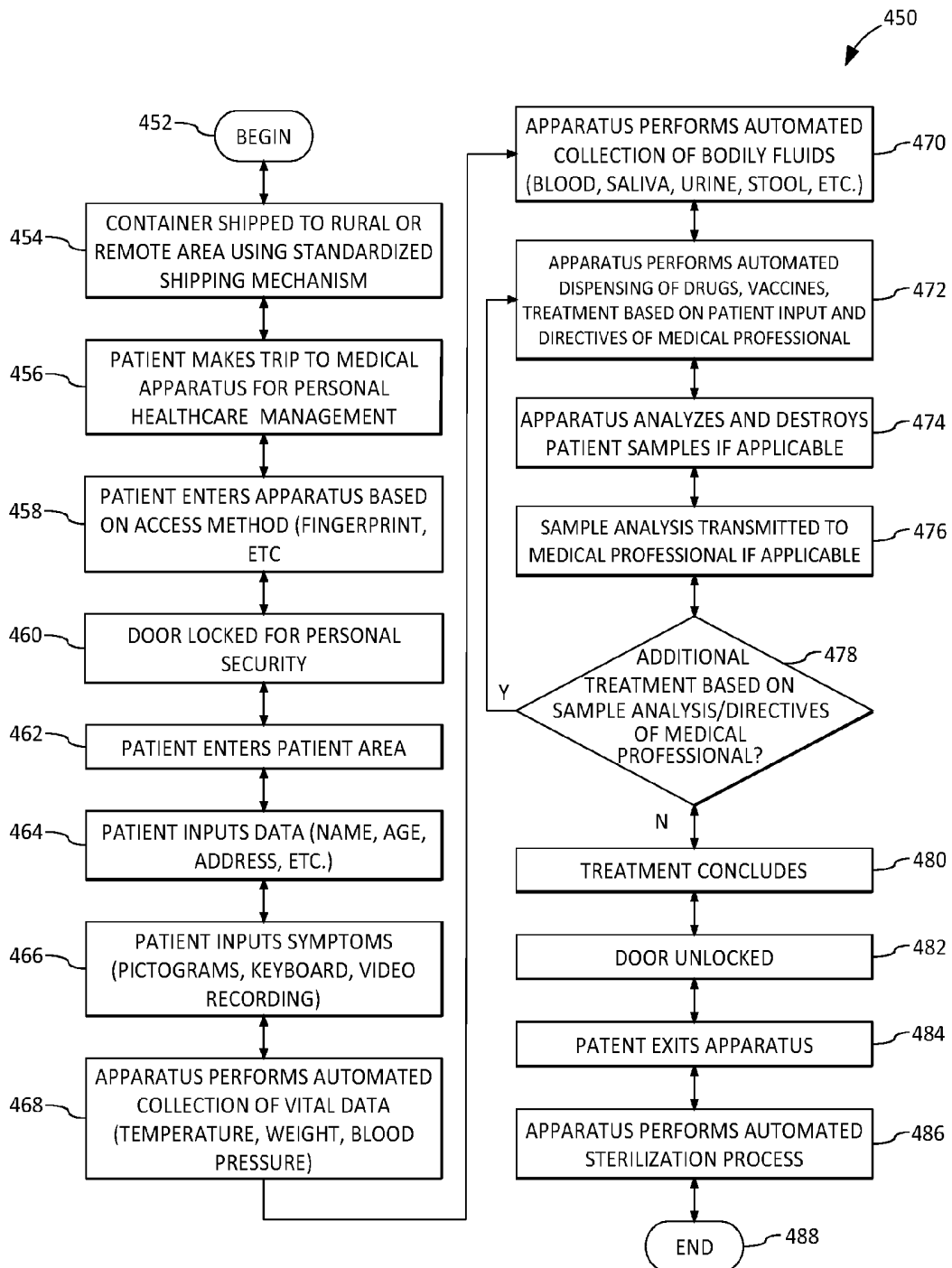

FIG. 13

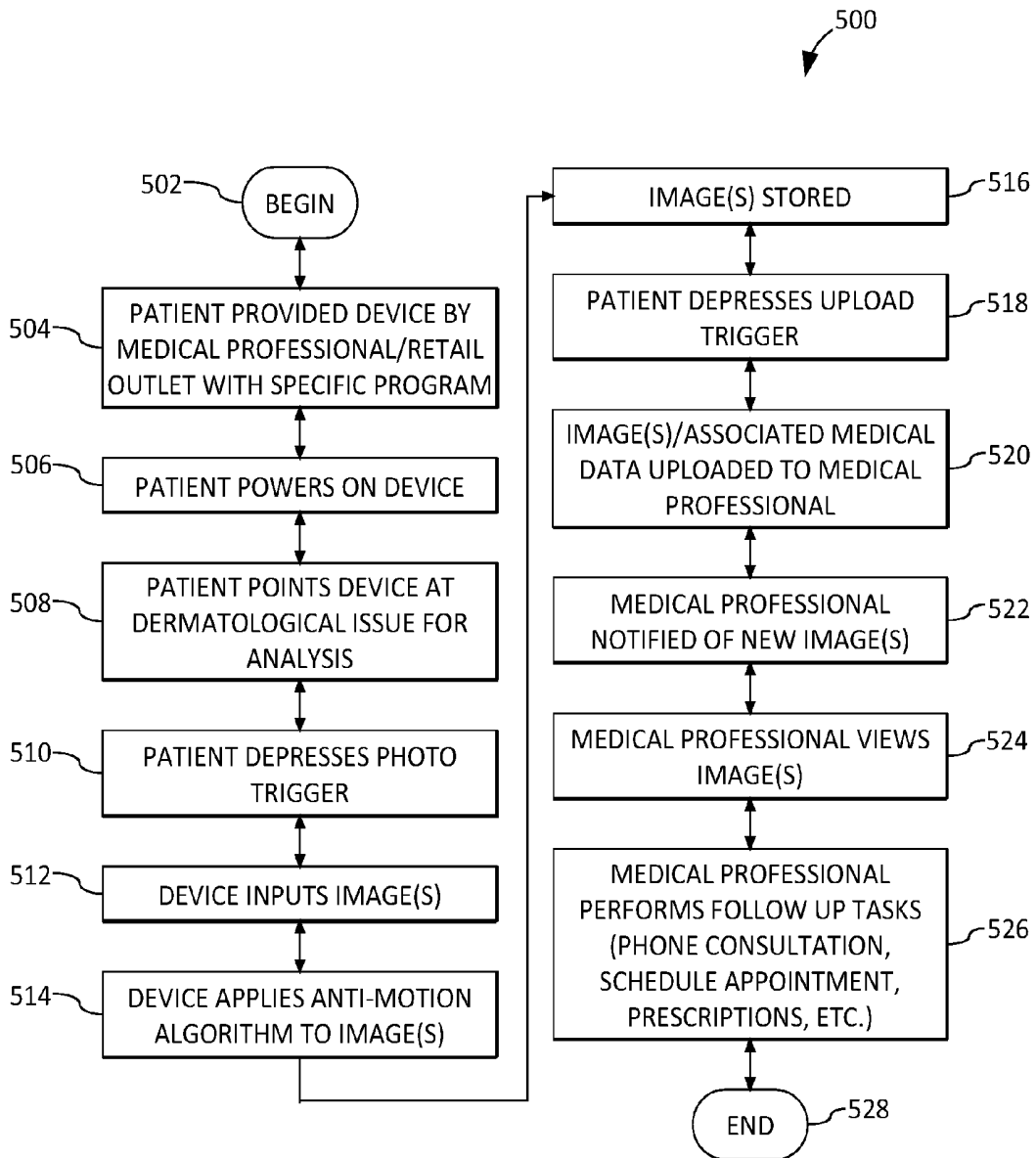

FIG. 14

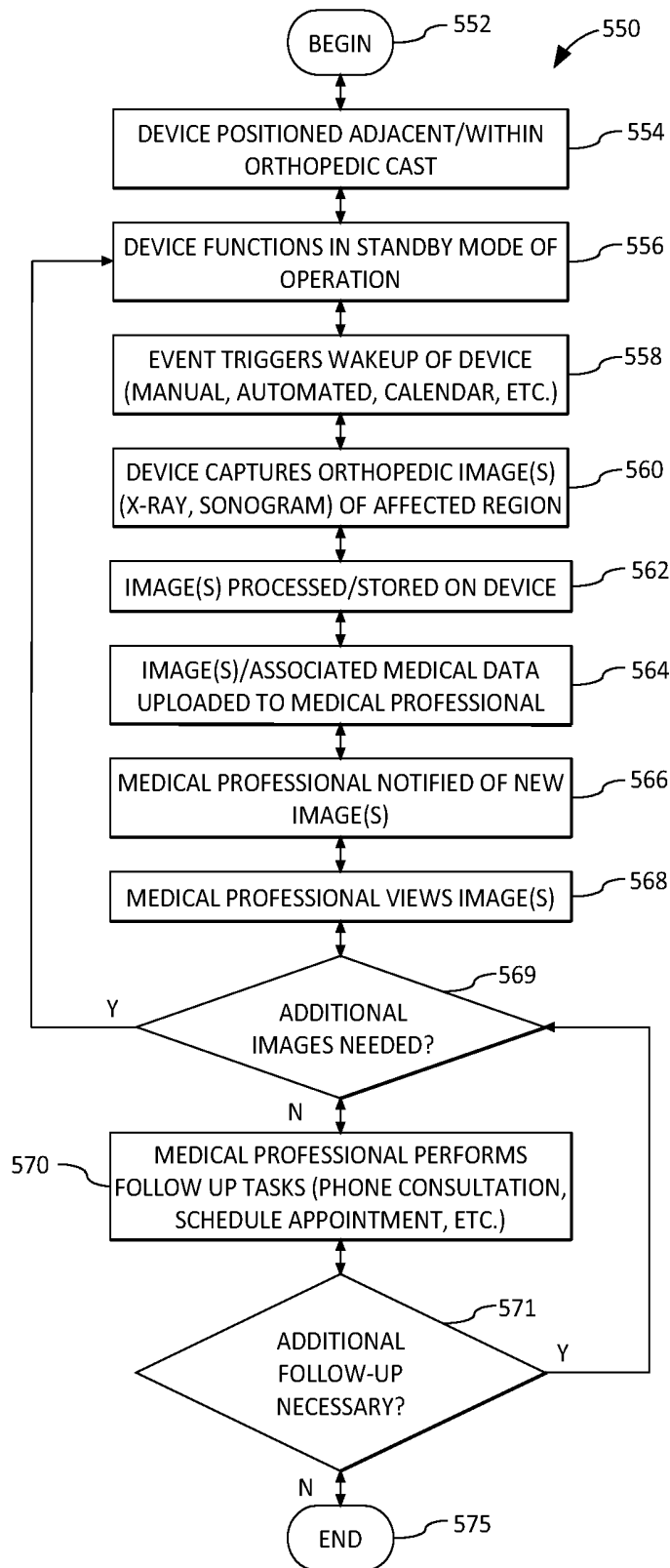

FIG. 15

REMOTE DELIVERY AND MONITORING OF HEALTH CARE

CROSS-REFERENCE TO RELATED APPLICATIONS

[0001] This Application is a Continuation of U.S. patent application Ser. No. 12/409,779, filed on Mar. 24, 2009, the contents of which are incorporated herein by reference.

BACKGROUND OF THE INVENTION

Field of the Invention

[0002] The present invention relates in general to computers and computer-assisted devices, and more particularly to apparatus, method and computer program product embodiments of devices for providing medical care with the remote assistance of a medical professional.

Description of the Related Art

[0003] Computers and computer systems are found in a variety of settings in today's society. Computing environments and networks may be found at home, at work, at school, in government, and in other settings. Computers and computer systems, including associated data storage, are increasingly being utilized to lower costs, increase productivity, provide security, and a host of other functions.

[0004] In the medical industry, the resources of medical professionals are increasingly spread in a variety of areas. In addition, demand for care has increased, while the supply, particularly of primary care physicians, has not. As a result, an alternative mechanism to meet medical need, such as providing remote contact with medical professionals for routine medical care, is needed. This alternative mechanism would help the medical professional better manage the increasing demand on their available resources, principally time, and allow for greater access to care for more patients. Currently, an effort is underway to facilitate medical consultations using computers and computing systems. This current effort, as of yet, has not fully addressed the need.

[0005] Providing health care in remote areas has been a challenge for decades. Traditionally, teams of healthcare professionals combine their talents and skills and engage in "missions" to areas where healthcare is required. These missions are limited in scope and duration, and generally rely on donations of time and equipment by the participants. Healthcare is only provided during the course of the missions, and follow-up care is rarely available for those in the area the mission visits. This has been the traditional method of first and second world nations providing healthcare to rural areas for many years, and there are few advances in this method.

SUMMARY OF THE INVENTION

[0006] In light of the foregoing, a need exists for tools allowing for the collection of medical data locally from a patient and supervision of a remote medical professional. In addition, a need exists for mechanisms whereby medical care may be provided to remote areas where accessibility to such care has been traditionally limited.

[0007] Accordingly, in one embodiment, by way of example only, an automated medical apparatus for providing medical care in remote areas to a patient is provided. The medical apparatus comprises a container having corrugated

steel enclosure on all sides and transportable using a standardized commercial shipping mechanism, the container having a door with a handle and lock mechanism for secure entry and secure accommodation of the patient for treatment. The container has integrated into an inner ceiling side of the container, a plurality of automated dispensers, the dispensers configured for dispensing sterilization material upon determining by the apparatus that the door has been opened and closed, a first time and a second time respectively, such that the patient is assumed to have completed the treatment and exited the container.

[0008] The medical apparatus further includes a power management device housed within the container, the power management device providing power to each of a patient interface, a medical device interface, and a processor; the patient interface housed within the container and the patient interface locally receiving a patient input from the patient during the treatment under remote supervision of a medical professional.

[0009] The medical apparatus further includes the medical device interface coupled to the patient interface, the medical device interface having a communications port facilitating a modular installation of a region-specific medical device to obtain medical information from the patient during the treatment; and the processor in communication with each of the medical device interface and the patient interface. The processor processes each of the patient input and the medical information obtained during the treatment in accordance with a directive of the medical professional.

[0010] Additional exemplary embodiments are disclosed herein and supply related advantages.

BRIEF DESCRIPTION OF THE DRAWINGS

[0011] In order that the advantages of the invention will be readily understood, a more particular description of the invention briefly described above will be rendered by reference to specific embodiments that are illustrated in the appended drawings. Understanding that these drawings depict exemplary embodiments of the invention and are not therefore to be considered to be limiting of its scope, the invention will be described and explained with additional specificity and detail through the use of the accompanying drawings, in which:

[0012] FIG. 1 illustrates an exemplary computing environment of which aspects thereof may be incorporated into embodiments of the present invention;

[0013] FIG. 2 illustrates an exemplary apparatus for providing medical care to rural and remote areas;

[0014] FIG. 3 illustrates an exemplary patient area of the apparatus depicted in FIG. 2;

[0015] FIG. 4 illustrates an exterior view of the exemplary apparatus depicted in FIG. 2;

[0016] FIG. 5 illustrates a system of communication between the apparatus depicted in FIG. 2 and a remote server accessible by a medical professional;

[0017] FIG. 6 illustrates a device for obtaining dermatological images for remote view by a medical professional;

[0018] FIG. 7 illustrates charging functionality of the device illustrated in FIG. 6;

[0019] FIG. 8 illustrates exemplary internal electronic components of the device illustrated in FIG. 6;

[0020] FIG. 9 illustrates an additional system of communication between the device illustrated in FIG. 6 and remote servers accessible by a medical professional;

[0021] FIG. 10 illustrates various views of a device for obtaining orthopedic images of a patient;

[0022] FIG. 11 illustrates exemplary internal components of the device illustrated in FIG. 10;

[0023] FIG. 12 illustrates an additional system of communication between the device illustrated in FIG. 10 and a remote server accessible by a medical professional;

[0024] FIG. 13 illustrates an exemplary method of operation of the apparatus illustrated in FIG. 2;

[0025] FIG. 14 illustrates an exemplary method of operation of the device illustrated in FIG. 6; and

[0026] FIG. 15 illustrates an exemplary method of operation of the device illustrated in FIG. 10.

DETAILED DESCRIPTION OF THE DRAWINGS

[0027] The illustrated embodiments below provide mechanisms for remote delivery and monitoring of health-care to patients. For example, in one embodiment, health dermatological health information is obtained using a specialized device and conveyed to a medical professional for remote diagnosis and monitoring purposes. In an additional embodiment, orthopedic health information is obtained using an additional specialized device and conveyed to a medical professional for monitoring purposes. In still an additional embodiment, an apparatus is delivered to a rural or remote area. The apparatus includes tools for obtaining medical data and treatment under the supervision of a medical professional. In each of the illustrated embodiments, the medical information is obtained from the patient without the need for onsite medical attendance of the medical professional. This frees the medical professional's resources to be spread across a greater area, and allows the delivery of medical care to locations where access by a medical professional has typically been difficult or impossible.

[0028] Embodiments of the invention may be described herein in terms of functional and/or logical block components and various processing steps. It should be appreciated that such block components may be realized by any number of hardware, software, and/or firmware components configured to perform the specified functions. For example, an embodiment of the invention may employ various integrated circuit components, e.g., memory elements, digital signal processing elements, logic elements, look-up tables, or the like, that may carry out a variety of functions under the control of one or more microprocessors or other control devices. In addition, those skilled in the art will appreciate that embodiments of the present invention may be practiced in conjunction with any number of data transmission and data formatting protocols and that the system described herein is one example embodiment of the invention.

[0029] For the sake of brevity, conventional techniques related to signal processing, data transmission, signaling, network control, the 802.11 family of specifications, wireless networks, additional communications systems and specifications, and other functional aspects of the systems (and the individual operating components of the systems) may not be described in detail herein. Furthermore, the connecting lines shown in the various figures contained herein are intended to represent example functional relationships and/or physical couplings between the various elements. It should be noted that many alternative or additional functional relationships or physical connections may be present in an embodiment of the invention.

[0030] The following description refers to elements or nodes or features being "connected" or "coupled" together. As used herein, unless expressly stated otherwise, "connected" means that one element/node/feature is directly joined to (or directly communicates with) another element/node/feature, and not necessarily mechanically. Likewise, unless expressly stated otherwise, "coupled" means that one element/node/feature is directly or indirectly joined to (or directly or indirectly communicates with) another element/node/feature, and not necessarily mechanically. The term "exemplary" is used in the sense of "example," rather than "model." Although the figures may depict example arrangements of elements, additional intervening elements, devices, features, or components may be present in an embodiment of the invention.

[0031] Turning to FIG. 1, an exemplary computer environment 10 in which aspects thereof may be incorporated into one or more embodiments of the present invention as will be further described is illustrated. Environment 10 includes a computer 12. The computer 12 comprises a processor 14 and a memory 6, such as random access memory (RAM). The computer 12 is operatively coupled to a display 19, which presents images such as windows to the user on a graphical user interface 18. The computer 12 may be coupled to other devices, such as a keyboard 16, a mouse device 20, a printer 28, etc. Of course, those skilled in the art will recognize that any combination of the above components, or any number of different components, peripherals, and other devices, may be used with the computer 12.

[0032] Generally, the computer 12 operates under control of an operating system (OS) 18 (e.g. z/OS, OS/2, LINUX, UNIX, WINDOWS, MAC OS) stored in the memory 6, and interfaces with the user to accept inputs and commands and to present results to the patient, for example through a graphical user interface (GUI) module 32. In one embodiment of the present invention, the OS 18 executes an application program 11 to gather medical information from a patient. Although the GUI module 32 is depicted as a separate module, the instructions performing the GUI functions can be resident or distributed in the operating system 18, the application program 11, or implemented with special purpose memory and processors.

[0033] Computer 12 includes a database 40. Database 40 may store a variety of relational information associated with patients, including vital information, medical histories, drug interactions, treatment instructions, and the like. Accordingly, database 40 is shown including a number of medical data files 15. Each of the medical data files 15 may be accessed by the database 40 using application program 11, for example. The skilled artisan will appreciate that application program 11, database 40 and medical data files 15 may vary in configuration and functionality according to a particular implementation.

[0034] The computer 12 also implements a compiler 13 that allows an application program 11 written in a programming language such as COBOL, PL/1, C, C++, JAVA, ADA, BASIC, VISUAL BASIC or any other programming language to be translated into code that is readable by the processor 14. After completion, the computer program 11 accesses and manipulates data stored in the memory 6 of the computer 12 using the relationships and logic that was generated using the compiler 13. The computer 12 also optionally comprises an external data communication device 30 such as a modem, satellite link, Ethernet card, wireless

link or other device for communicating with other computers, e.g. via the Internet or other network.

[0035] Data storage device **22** is a direct access storage device (DASD) **22**, including one or more primary volumes holding a number of datasets. DASD **22** may include a number of storage media, such as hard disk drives (HDDs), tapes, and the like. Data storage device **36** may also include a number of storage media in similar fashion to device **22**. The device **36** may be designated as a backup device **36** for holding backup versions of the number of datasets primarily stored on the device **22**. As the skilled artisan will appreciate, devices **22** and **36** need not be located on the same machine. Devices **22** may be located in geographically different regions, and connected by a network link such as Ethernet. Devices **22** and **36** may include one or more volumes, with a corresponding volume table of contents (VTOC) for each volume.

[0036] In one embodiment, instructions implementing the operating system **8**, the computer program **11**, and the compiler **13**, as well as the database **40** and medical data fileset **14** are tangibly embodied in a computer-readable medium, which may include one or more fixed or removable data storage devices, such as a zip drive, disc **24**, hard drive, DVD/CD-ROM, digital tape, etc., which are generically represented as the disc **24**. Further, the operating system **8** and the computer program **11** comprise instructions which, when read and executed by the computer **12**, cause the computer **12** to perform the steps necessary to implement and/or use the present invention. Computer program **11** and/or operating system **8** instructions may also be tangibly embodied in the memory **6** and/or transmitted through or accessed by the data communication device **30**. As such, the terms “article of manufacture,” “program storage device” and “computer program product” as may be used herein are intended to encompass a computer program accessible and/or operable from any computer readable device or media.

[0037] Embodiments of the present invention may include one or more associated software application programs **11** that include, for example, functions for managing a distributed computer system comprising a network of computing devices, such as a storage area network (SAN). Accordingly, processor **14** may comprise a storage management processor (SMP). The program **11** may operate within a single computer **12** or as part of a distributed computer system comprising a network of computing devices. The network may encompass one or more computers connected via a local area network and/or Internet connection (which may be public or secure, e.g. through a virtual private network (VPN) connection), or via a fibre channel SAN or other known network types as will be understood by those skilled in the art. (Note that a fibre channel SAN is typically used only for computers to communicate with storage systems, and not with each other.) As one skilled in the art will appreciate, however, various additional components of the environment **10** may work individually or in concert to define, initialize, and perform the functionality for facilitating deduplication product testing as will be further described.

[0038] In one of the illustrated embodiments, an on-demand, self-sustaining and self-sufficient advanced medical unit is provided for implementation in emerging/developing markets. An exemplary unit may include an unmanned structure, such as a shipping container, which contains all the instrumentation required to conduct a par-

ticular set of medical tests. Users of the apparatus enter the structure, provide personal credentials, and then have certain tests or medical procedures executed depending on need. Data would be collected by the apparatus and transmitted electronically in a secured manner to medical professionals, such as doctors, for analysis.

[0039] Diagnoses by the medical professional may be transmitted back to the apparatus for retrieval by the user at a later date. All patient data is secure, encrypted, and private. Medical equipment in the structure is secured in such a way as to prevent vandalism. Sterilization of the medical equipment would be automatic. The structure could easily be moved from one area to another via methods such as truck transport or helicopter transport. Power to the structure is provided by a sustainable, stand-alone method such as solar cells, yet also allows for local power connections.

[0040] The standalone apparatus described above advances providing medical care to areas where access to traditional medicine has been limited or nonexistent. First, the apparatus is unmanned, which reduces costs necessary to support onsite personnel. Second, the apparatus is automated, which reduces the chances for human error and contamination in the collection of medical samples. Third, the apparatus is sustainable through the use of self-contained, onboard power. Fourth, the apparatus is expeditious, as information is transmitted on a frequent basis for review by offsite medical staff. Finally, the apparatus is mobile, and can be moved to many areas over time, providing a broader reach of medical care than currently possible.

[0041] In one exemplary embodiment, the standalone apparatus described above is capable of being transported to various locations, using means such as truck, train, helicopter, or ship. The apparatus is housed in a shelter similar in size to a shipping container of the sort that are routinely used for exporting goods from various countries, and which can be seen stacked on trains and ships throughout the world. Equipment necessary to provide unmanned healthcare is installed within the container.

[0042] To assist the apparatus described above in providing unassisted, stand-alone healthcare, a renewable, self-contained power source for powering the apparatus may be integrated. Such a power system may include solar energy panels, an internal generator, or battery. A power connection for external attachment, in the event that external power is available, may also be included. Finally, a communication center for collecting and transmitting information to reviewing medical professionals may implement several communications mechanisms such as WiFi, Internet, Satellite, and cellular communications protocols. As will be further described, the patient area portion of the apparatus may be adapted for collection of patient data (such as vital statistics and the like), as well as for administration of healthcare related items (such as vaccines, medications, etc.).

[0043] Turning to FIG. 2, an exemplary apparatus **100** for providing medical care in remote and rural areas as described previously is illustrated in block diagram format. Apparatus **100** includes a container **102** or similar housing. Container **102** may be comprised of a corrugated steel material typically used in shipping containers to provide strength. As the skilled artisan will appreciate, a variety of additional materials may be implemented. Container **102** houses a patient area **104**. A patient accesses the patient area through a door **116** (illustrated through arrow **114**). The patient may interact with the apparatus to provide or collect

medical information, and receive treatment inside patient area **104**. Embodiments may include places for the patient to sit (not shown), provide samples, and otherwise interact with the apparatus **100**.

[0044] A medical device interface **106** portion provides an interface between the medical processing area **108** and the patient area **104**. Interface **106** includes several communications ports **118** in which one or more input devices **120** tailored to the region of deployment are modularly connected. Examples of such input devices **120** will be described further, following. Medical processing area includes a computer environment **10** such as the environment **10** depicted in FIG. 1 with specialized application to gathering, processing, and dispensing medical information and treatment. Again, as the skilled artisan will appreciate, the particular components of environment **10** will vary according to a particular implementation. For example, the computer environment **10** may include necessary electronics equipment for processing samples collected in the patient area **104**.

[0045] Medical processing area **108** is also connected to communications equipment **110** and power management area **112**. Power management area **112** performs power functions for the apparatus **100**. Power management area may include a variety of power sources, such as one or more onboard batteries **122**, a generator **124**, and/or a solar interface **126**. Power management area may be adapted to supply all of the power needs for the apparatus **100**, including the components in computer environment **10** and devices **120** connected to the medical device interface **106**. Alternatively, power management area **10** may include equipment allowing the connection of the apparatus **100** to the local power grid.

[0046] Communications equipment **110** includes one or more communications devices **128** providing the functionality necessary to send/receive communications to/from offsite medical personnel. Portions of the computer environment **10** may be used as or in conjunction with communications equipment **110**. Communications equipment may include devices such as cellular devices, WiFi, Internet, Voice Over Internet Protocol (VOIP), and similar devices to allow for the exchange of information between apparatus **100** and the medical professional.

[0047] Turning to FIG. 3, an exemplary interior **130** of a patient area is illustrated. Interior **130** includes a variety of equipment necessary to collect and analyze information, and dispense treatment to a patient. Interior **130** as illustrated includes several exemplary medical sampling and treatment devices that are operable by the patient and observable remotely under the supervision of the medical professional. GUI interface **144** includes a platform for the collection of medical information with an integrated GUI display **148** and communications device **150**, in this case, a telephone device. In other exemplary embodiments, communications device **150** may include such devices as cameras and imaging devices, microphones, keyboards, and other input devices (not shown). Further, GUI display **148** may be adapted to be touch sensitive for collection of patient input. A cuff device **146** is provided for obtaining medical data such as a patient's blood pressure. For the sake of convenience, a chair or other seating device in which the patient is seated is not shown.

[0048] GUI interface **144** is an example of one or more modular devices that are connectable into the medical device

interface. Other exemplary devices are additionally shown, including a scale **142** and interconnected display **144** for obtaining weight information, and a dispensary **132**. Dispensary **132** is adapted for dispensing treatment related items, such as first-aid materials **134** which may be obtained by the patient. Dispensary **132** may be adapted for providing a variety of health care related items, as the skilled artisan will appreciate. Below dispensary **132** is a lavatory **140** for use by a patient.

[0049] A commode **146** is provided. Commode **146** may be adapted to obtain samples of medical data, such as a urine sample, internally (shown by reference number **145**). An additional interface device **106** is located between the commode **146** and the lavatory **140** for patient interaction. Interface device **106** may include an additional GUI **139** for providing visual cues to the patient, as well as input buttons **135** and **137**. Interface **106** may also include a collection window **138** for obtaining samples from the patient and/or dispensing functionality. For example, window **138** may dispense certain drugs **136**, vaccines, and the like depending upon a particular patient input, sample analysis, interaction with the medical professional, etc.

[0050] Two dispensers **164** of sterilization material **166** are incorporated into the ceiling of the interior **130** to provide for automated sterilization functionality of the interior **130** once the patient concludes treatment. Such automated sterilization functionality may be enabled once the patient opens and closes the door, and the apparatus has determined that the patient has exited the patient area.

[0051] Turning to FIG. 4, an external view **180** of the apparatus **100** (FIG. 2) is depicted. Container **102** is comprised of corrugated steel, with handles **181** provided for ease of commercial shipment. Power supply **183** is connected internally to power management area **112** (FIG. 2) for external connection **186** of electrical power via plug **188**. A door **160** includes a handle and lock mechanism to allow for secure entry and treatment of the patient inside. Several solar panels **182** are arranged along the top portion of the apparatus for collection of solar rays. The solar panels **182** are also connected internally to the power management area. Finally, an antenna **184** is connected internally to the communications equipment **110** (FIG. 2) for sending and receiving information as the skilled artisan will appreciate.

[0052] FIG. 5 illustrates an exemplary system **190** of communication between the apparatus **100** and a remote server accessible by the medical professional. The apparatus **100** may implement wireless signals **192**, **194** which are collected and transmitted by transceiver **208** as illustrated via the depicted communications paths. Satellite communication may relay the wireless signals **192**, **194** to an additional transceiver **204**, where it is transmitted over network **206** (such as the World Wide Web or a local Intranet or Extranet) to the remote server **196**. The transceiver **208** may also send the communication directly to the remote server **196**. Alternatively still, the apparatus **100** may be hard-wired to the remote server **196**. In each case, data, images, information, voice and/or auditory communication, etc. may be relayed to/from the apparatus to/from the remote server **196** where it may be viewed on display **198** and shown on display **200**.

[0053] As the skilled artisan will appreciate, the illustrated communications paths may include a variety of communications mechanisms. For example, the paths may be compliant with a universal serial bus (USB) communications

protocol, an internet protocol (IP), an Institute for Electrical and Electronics Engineers (IEEE) wired or wireless communications protocol, a wireless application protocol (WAP), a local area network (LAN) protocol, a wide area network (WAN) protocol, a global system for mobile communication (GSM) protocol, and an AppleTalk® protocol.

[0054] An exemplary method of operation of the apparatus **100** may proceed as follows. As a first step, the apparatus is placed (such as commercially shipped or dropped) in a rural or remote area, or in emerging/developing markets for health care. Depending on the particular region, the container may be updated with all necessary interfaces, including software, power, and medical necessities required to accommodate particular health needs. The patient then makes a trip to the apparatus for personal healthcare management. The patient enters the apparatus, and door is locked for personal security. The patient seats himself or herself in the patient area, where he or she interacts with the apparatus. The following may occur: (1) input of patient data such as name, age, address, etc., (2) input of patient symptoms or concerns (this could be via pictograms, for more common ailments, through the use of a keyboard, for more detailed descriptions, or perhaps through a video recording of a patient narrative), (3) automated, unmanned collection of vital data such as temperature, weight, blood pressure, (4) automated, unmanned collection of blood, saliva, urine, stool samples or other bodily fluids, and (5) automated, unmanned dispensing of drugs, vaccines, and other treatments appropriate to the device. The apparatus may analyze, and later destroy, collected samples. Information representative of the samples may then be transmitted via the communications equipment. After patient has completed their visit, the door is unlocked, and the next patient is free to enter.

[0055] Additional embodiments may make possible the use of remotely administered healthcare. Such an additional embodiment may assist in the monitoring and treatment of dermatological issues. Currently, most dermatological care is provided through in-office doctor visits. Of these visits most consist of routine check-ups, which are administered by a dermatologist. For many people dermatological care is seldom, if ever sought out. But for patients that have higher risks for skin diseases, based on personal and/or family histories, these visits can come once every six months, or even more frequently, especially for those that have many non-routine/unscheduled visits.

[0056] To help reduce cost and improve healthcare resource allocation associated with dermatological issues, a mechanism may be implemented whereby a patient may convey dermatological information, particularly routinely collected information, to the medical professional at a remote location for analysis. In one embodiment, this mechanism allows patients to perform in-home dermatological examinations using a portable device, which uploads high resolution pictures to electronic data repositories owned and operated by their dermatologists' offices.

[0057] In one embodiment, an apparatus is provided allowing for in-home dermatological monitoring through a portable, wireless, and reusable device. The patient obtains the device from their dermatologist's office, preprogrammed to connect wirelessly to a specific upload location. Alternatively, the device can be bought from a retail outlet, and easily programmed by the user to connect to a particular image upload location. In the privacy of their own home, the patient uses the device to take pictures of the area(s) of skin

where there is/are concerns. The device may photograph as large an area of the body as needed by taking multiple images. Once the images are captured, the patient initiates an upload, and will be alerted when the upload is complete. The patient's dermatologist can then view and assess the images from their local machine, or through remote access. Such a device helps to make dermatological care more efficient, while being extremely easy to use for patients and doctors. Anyone with or without technical knowledge should be able to use the device without difficulty.

[0058] The device may feature a portable, rechargeable, and small footprint. Only a few large buttons may be located on the device to improve ease of use. The device may include a built-in flash memory for temporarily storing images. For security purposes, all images may be deleted upon successful upload. An indicator light (such as a blue light) may illuminate when at least one image is stored on local memory. An additional indicator light (such as a green light) may illuminate when the image(s) are successfully uploaded and deleted locally.

[0059] A high-resolution imaging device, such as but not necessarily limited to, a camera, is integrated into the device and specially adapted for capturing macro images. Additionally, software installed on the device, such as an anti-motion algorithm, may be applied to the images to improve quality. A lighting mechanism may also be incorporated for improving quality and capturing high-resolution dermatological images. Finally, the device may use a number of wireless mechanisms to communicate the image data to the medical professional.

[0060] Turning now to FIG. 6, a system **250** for capturing dermatological images of a patient using an exemplary device **258** is shown in view of the foregoing discussion. Device **258** includes a housing **260**, a high-resolution imaging device and lens **262**, a power button **264**, a photo button **266**, and an upload button **268**. A specialized lighting device **270** is adapted for capturing macro dermatological images. One or more indicator lights provides status information to the patient **252**.

[0061] As is shown, the device **258** is aimed at a dermatological issue **256** in question on the patient's arm **254**, such as a skin lesion that is in the process of healing. The patient powers on the device by pressing the power button **264**, and captures one or more dermatological images by pressing the photo button **266**.

[0062] FIG. 7 illustrates a more detailed view of the device, illustrating a charging system **280**. The exemplary device shown in FIG. 6 is again illustrated, including buttons **264**, **266**, and **268**, imaging device **262**, indicator light(s) **272**, and specialized lighting device **270**. A charging device **282** includes a housing **284** adapted for receiving the housing **260** of the device. A power cord **286** and plug **288** supplies power to the charging system.

[0063] Exemplary electronic components of the device are illustrated in FIG. 8 in block diagram form. As was previously mentioned, some of the components in computing environment **10** (FIG. 1), such as memory, processing, operating systems, and the like may be adapted and incorporated for the specialized purpose of obtaining dermatological images. The device **258** includes a wireless communications interface **300** for communication to/from a remote server. Wireless communications interface **300** may be adapted for use and compatibility with the variety of previously mentioned communications mechanisms. A processor

302 is adapted for processing images captured by the imaging device 312. An anti-motion algorithm 304 may be applied to the processing of the images (whether during the capturing phase or post capture) to enhance image quality. The images 308 are stored in a memory location 306.

[0064] FIG. 9 illustrates an additional exemplary system of communication between the device 258 and remote servers accessible by a medical professional, such as a dermatologist. The wireless communications interface, upon a depression of the upload button, uses wireless signals 320, 322, and 330, which are transmitted to one or more remote servers 340 and 342. In one embodiment, the remote server 340 is located proximately to the patient, such as the patient's home computer. The server 340 then transmits the image data across communications path 328 to the server 342 in the medical professional's office. In both or either case, the patient and/or the medical professional may view the images on GUI screens 325 and 333 as shown on displays 324 and 332.

[0065] Still additional embodiments may make possible the use of remotely administered healthcare. These additional embodiments may assist in the monitoring and treatment of orthopedic injuries. Currently when someone has a broken bone, many times healing of the bone requires cast setting. Normally, the medical professional is familiar with the bone being set and estimating a healing time. After the specified time the patient returns to the medical professional, the cast is removed and an X-ray has to be taken again to determine the state of the healing process. If the bone is not completely healed then a recast will be performed and the medical professional will again estimate the healing time. This process to evaluate the broken bone can take several attempts, incurring additional time and expense to the patient, the medical professional and insurance company. In addition, a certain amount of risk is involved with the unknowns of removing and resetting casts.

[0066] To reduce cost and resource use associated with routine visits to monitor orthopedic healing, exemplary embodiments as will be described may be implemented to assist in such tasks. One embodiment utilizes a reusable, portable, wireless orthopedic monitoring device. There are numerous possible advantages of such a device. Unnecessary visits to the medical professional are reduced or eliminated. The medical professional is able to monitor the healing process remotely. If a patient heals faster than expected, an office visit can be scheduled to remove the cast and begin any physical therapy. If the healing process is taking longer than expected, the device can remain on the patient until the doctor is ready to remove it. This not only saves money and materials associated with recasting, but also reduces some of the trauma associated with these types of office visits (particularly for children and elderly persons).

[0067] The embodiment uses a portable device that is strategically embedded into a reusable, portable, wireless orthopedic monitoring device. This device is positioned above the original fracture and obtains X-ray or ultrasound pictures/images of the healing bone. The device can be configured/programmed by the physician to take a predetermined number of images per day or per week. These images are then wirelessly uploaded using a wireless component embedded into the portable device to an Internet connected device in the patient's home, office or any other remote site. The internet connected device will then upload the same images to a remote data repository, owned and

controlled by an orthopedic office. The images can be viewed remotely by the medical professional to monitor the healing process, who will be alerted quickly to problems. In addition, if the fracture being monitored has healed faster than expected, the patient can be relieved of this orthopedic monitoring device and rehabilitation can begin sooner.

[0068] The device described above may include such functionality as network connectivity, built-in wireless and/or cellular capability, a standby power component (where power to the device is regulated in a standby mode until images are obtained), and an accessible battery compartment for replacement of batteries. FIG. 10 illustrates several views 350, 358 of an exemplary such device 356. Device 356 is positioned adjacent to, or within the orthopedic cast 354 of a patient's arm 352. Device 356 includes one or more indicator lights 360 to indicate low battery power. In view 358, the device is positioned between the cast and the patient's skin. This is more clearly shown in the bottom, cross-sectional view, where device 356 is positioned interiorly to the cast 354.

[0069] FIG. 11 illustrates exemplary electronic components of the device in block diagram form. As was previously mentioned, some of the components in computing environment 10 (FIG. 1), such as memory, processing, operating systems, and the like may be adapted and incorporated for the specialized purpose of obtaining orthopedic images. The device 356 includes a wireless communications interface 396 for communication to/from a remote server. Wireless communications interface 396 may be adapted for use and compatibility with the variety of previously mentioned communications mechanisms.

[0070] A power system 398 including a battery 400 and one or more indicator lights 402 is connected to the wireless communications interface 396. A memory 392 for storing orthopedic images 394 is connected to the power system 398 and a biomedical device 370. Biomedical device 370 is adapted for obtaining orthopedic images from the patient. Device 370 may include components for obtaining x-ray images and/or components for obtaining sonogram images of the patient. Accordingly, device 370 includes an acoustic transducer 380 for sending and receiving pulses of sound. An impedance-matching material 382 is positioned between the acoustic transducer and the housing of the device 356 to increase sound transfer efficiency. A processor 388 processes the received sound to generate sonogram images 394.

[0071] In similar fashion, an x-ray source and detector device 384 may also be incorporated. The x-ray source portion of source/detector 384 is shielded with a low-density insulating material 386 containing a high-Z substance. In either case of the x-ray source/detector 384 and transducer 380 devices, an application program 390 may be used with the assistance of processor 388 to generate the sonograms and/or x-ray images as the skilled artisan will appreciate. In one embodiment, the application program calendars a set schedule of days/times in which images of the patient will be obtained. The power system sets the biomedical device in a lower power/sleep mode of operation when the device is not active. Accordingly, the biomedical device may obtain a predetermined number of images according to a schedule set by the medical professional.

[0072] FIG. 12 illustrates an additional exemplary system 404 of communication between the device 356 and a remote server accessible by a medical professional, such as a physician. The wireless communications interface, upon

activation (such as directed by the application program, a wake up signal from computer 412, or another mechanism as the skilled artisan will appreciate), uses wireless signal 410 to convey orthopedic image data to computer 412. In one embodiment, the computer 412 is located proximately to the patient, such as the patient's home computer. The computer 412 then transmits the image data across network 416, or alternatively wirelessly using signal 414 to the server 418 in the medical professional's office. The medical professional may then view and analyze the orthopedic image shown on display 420.

[0073] Turning to FIGS. 13-15, various methods are depicted as examples of patient monitoring and treatment using the mechanisms of the present invention. As one skilled in the art will appreciate, various steps in these methods may be implemented in differing ways to suit a particular application. In addition, the described methods may be implemented by various means, such as hardware, software, firmware, or a combination thereof operational on or otherwise associated with the storage environment. For example, the methods may be implemented, partially or wholly, as a computer program product including a computer-readable storage medium having computer-readable program code portions stored therein. The computer-readable storage medium may include disk drives, flash memory, digital versatile disks (DVDs), compact disks (CDs), and other types of storage mediums.

[0074] Turning first to FIG. 13, method 450 illustrates an exemplary method of operation of the medical apparatus depicted in FIG. 2. Method 450 begins (step 452) with the shipment or placement of the container to a rural or remote area using a standardized shipping mechanism (step 454). The patient makes a trip to the medical apparatus for personal healthcare management (step 456). The patient enters the apparatus based on a particular access method (fingerprint, key, voice recognition, etc.) (step 458). The door is then locked for personal security (step 460).

[0075] The patient enters the patient area (step 462) and provides patient input (such as name, age, address, etc.) (step 464). The patient inputs symptoms (such as by use of pictograms, keyboard, video recording, etc.) (step 466). The apparatus then performs automated collection of vital data (such as temperature, weight, and blood pressure) (step 468). The apparatus then performs automated collection of bodily fluids (such as blood, saliva, urine, stool, etc.) (step 470). Based on the patient input and/or a preliminary analysis of the sample(s), and under the direction of the medical professional, the apparatus then performs automated dispensing of drugs, vaccines, and other treatment (step 472).

[0076] The analysis of the patient sample may continue (for example, if a culture is required) for some time, perhaps following exit of the patient from the apparatus. Once the sample is finished undergoing analysis, it is destroyed (step 474), and the analysis is transmitted to the medical professional (step 476). If additional treatment based on a sample analysis and/or the directives of the medical professional is needed (step 478), then steps 472-478 continue until treatment concludes (step 480). The door is unlocked (step 482), the patient exits apparatus (step 484), and the apparatus performs an automated sterilization process (step 486). The method 450 then ends (step 488).

[0077] Turning now to FIG. 14, an exemplary method 500 for operation of the device 258 (FIG. 6) is illustrated. Method 500 begins (step 502) with the providing of the

device by a medical professional or retail outlet. The device is programmed with a specific program (step 504) for collecting dermatological images. As a next step, the patient powers on the device (step 506), the patient aims the device at a dermatological issue for analysis (step 508), and depresses the photo button to obtain one or more dermatological images (step 510). The device inputs the images (step 512), and applies an anti-motion algorithm to improve image quality (step 514). The images are stored (step 516) on onboard memory.

[0078] The patient then depresses the upload button (step 518) to upload the dermatological information. The images and associated dermatological data (such as imaging device number, patient information, time of day, date, etc.) is uploaded to the medical professional (step 520). The medical professional is notified of the new images (step 522). The medical professional views and analyzes the images (step 524), and then performs follow-up tasks based on the analysis (step 526), such as performing phone consultations, scheduling a follow-up appointment, writing a prescription, etc. The method 500 then ends (step 528).

[0079] Turning now to FIG. 15, an exemplary method 550 for operation of the device 356 is illustrated. Method 550 begins (step 552) with the positioning of the device either adjacent to, or within, an orthopedic cast (step 554). The device functions in a standby mode of operation (step 556) until an event triggers the device to awake (step 558), such as a manual wakeup, an automated trigger, a calendared event, and the like.

[0080] Once the device is made active, one or more orthopedic images (e.g., x-ray, sonogram) are captured (step 560). The images are processed and stored on the device (step 562), and later uploaded to the medical professional along with the associated medical data in similar fashion to that previously described in FIG. 14 (step 564). The medical professional is notified of the new images (step 566). The medical professional views and analyzes the images (step 568).

[0081] In some cases, additional orthopedic images need to be obtained during the course of a patient's healing process. If additional images need be obtained (such as due to the course of an estimated healing period still underway) (step 569), then the method 500 returns to step 556 in a standby mode of operation until the next event triggers the wakeup of the device (again, step 558). Steps 560-568 continue again as previously described.

[0082] Following the conclusion of obtaining all scheduled images, uploading the images to the medical professional, and analysis by the medical professional, the professional performs follow-up tasks based on the analysis (step 570), such as performing phone consultations, scheduling a follow-up appointment, writing a prescription, etc. If additional follow-up treatment is necessary (step 571), then the method 550 queries again whether additional images need be taken (again, step 569). If yes, then the images are scheduled and obtained as before (returning to step 556). Additional follow-up tasks are again performed (again, step 570). If no additional follow-up is necessary (again, step 571), then the method 550 ends (step 572).

[0083] While the foregoing methods 450, 500, and 550 provide exemplary functionality of the mechanisms of the present invention, the skilled artisan will appreciate that similar functionality may be carried out. For example, in additional embodiments, the apparatus 100 (FIG. 2) may be

adapted to contact emergency medical personnel in case of a medical emergency, such as a paramedic team or hospital emergency room. For example, if a patient provides diagnostic information indicating a medical emergency, appropriate responding personnel may be contacted. The diagnostic information may be electronically forwarded to the responding personnel for analysis.

[0084] Some of the functional units described in this specification have been labeled as modules in order to more particularly emphasize their implementation independence. For example, a module may be implemented as a hardware circuit comprising custom VLSI circuits or gate arrays, off-the-shelf semiconductors such as logic chips, transistors, or other discrete components. A module may also be implemented in programmable hardware devices such as field programmable gate arrays, programmable array logic, programmable logic devices, or the like.

[0085] Modules may also be implemented in software for execution by various types of processors. An identified module of executable code may, for instance, comprise one or more physical or logical blocks of computer instructions which may, for instance, be organized as an object, procedure, or function. Nevertheless, the executables of an identified module need not be physically located together, but may comprise disparate instructions stored in different locations which, when joined logically together, comprise the module and achieve the stated purpose for the module.

[0086] Indeed, a module of executable code may be a single instruction, or many instructions, and may even be distributed over several different code segments, among different programs, and across several memory devices. Similarly, operational data may be identified and illustrated herein within modules, and may be embodied in any suitable form and organized within any suitable type of data structure. The operational data may be collected as a single data set, or may be distributed over different locations including over different storage devices, and may exist, at least partially, as electronic signals on a system or network.

[0087] While one or more embodiments of the present invention have been illustrated in detail, the skilled artisan will appreciate that modifications and adaptations to those embodiments may be made without departing from the scope of the present invention as set forth in the following claims.

What is claimed is:

1. An automated medical apparatus for providing medical care in remote areas to a patient, comprising:
 - a container having corrugated steel enclosure on all sides and transportable using a standardized commercial shipping mechanism, the container having a door with a handle and lock mechanism for secure entry and secure accommodation of the patient for treatment; wherein the container has integrated into an inner ceiling side of the container, a plurality of automated dispensers, the dispensers configured for dispensing

sterilization material upon determining by the apparatus that the door has been opened and closed, a first time and a second time respectively, such that the patient is assumed to have completed the treatment and exited the container;

a power management device housed within the container, the power management device providing power to each of a patient interface, a medical device interface, and a processor;

the patient interface housed within the container, the patient interface locally receiving a patient input from the patient during the treatment under remote supervision of a medical professional;

the medical device interface coupled to the patient interface, the medical device interface having a communications port facilitating a modular installation of a region-specific medical device to obtain medical information from the patient during the treatment; and

the processor in communication with each of the medical device interface and the patient interface, wherein the processor processes each of the patient input and the medical information obtained during the treatment in accordance with a directive of the medical professional.

2. The apparatus of claim 1, wherein the power management device includes at least one of a power generator, battery, solar interface device, and power interface compatible with a local power grid.

3. The apparatus of claim 1, further including a communications device connected to the processor, the communication device transmitting the patient input and the medical information to the medical professional.

4. The apparatus of claim 1, wherein the region-specific medical device includes one of a medical sampling device for obtaining patient data and a medical sample, a medical treatment device for administering a treatment regime to the patient, and dispensing device providing a dispensary to the patient.

5. The apparatus of claim 4, wherein the medical sampling device included in the region-specific medical device obtains at least one of temperature, weight, and blood pressure medical information and collects at least one of blood, saliva, urine, and stool, and the dispensing device dispenses at least one of a drug and a vaccine.

6. The apparatus of claim 5, wherein the medical sampling device included in the region-specific medical device, subsequent to completion of the treatment by the patient, destroys the medical sample for security and sterilization purposes.

7. The apparatus of claim 1, wherein a portion of the container providing the secure accommodation of the patient for the treatment is automatically sterilized using at least one dispenser of sterilization material upon conclusion of the treatment.

* * * * *

专利名称(译)	远程传递和监测医疗保健		
公开(公告)号	US20180103893A1	公开(公告)日	2018-04-19
申请号	US15/844975	申请日	2017-12-18
[标]申请(专利权)人(译)	国际商业机器公司		
申请(专利权)人(译)	国际商业机器公司		
当前申请(专利权)人(译)	国际商业机器公司		
[标]发明人	FLEMING MARK LARA CHRISTINA COPELAND MICHAEL P SANCHEZ CALLINE K		
发明人	FLEMING, MARK LARA, CHRISTINA COPELAND, MICHAEL P. SANCHEZ, CALLINE K.		
IPC分类号	A61B5/00 A61B10/00		
CPC分类号	A61B2560/0475 A61B5/0059 A61B10/0045 A61B2560/0431 A61B2560/0456 A61B5/0022 A61B5/0013 A61B2090/376 A61B2090/378 A61B5/74 A61B5/7207 A61B2560/0214 A61B5/6812 A61B5/7445 A61B5/445 G16H40/67 G06F19/3418		
外部链接	Espacenet USPTO		

摘要(译)

提供了一种用于在偏远地区向患者提供医疗护理的自动化医疗设备。该设备包括在所有侧面上具有波纹钢外壳并且可使用标准化的商业运输机构运输的容器，该容器具有带有手柄和锁定机构的门，用于牢固地进入和牢固地容纳患者进行治疗。容器已经集成到容器的内部天花板侧，多个自动分配器，分配器被配置用于分别在第一时间和第二时间由装置确定门已经被打开和关闭时分配消毒材料，例如假定病人已经完成治疗并退出容器。此外，该设备包括电力管理装置，处理器，医疗装置接口和患者接口。

