



US 20170095680A1

(19) **United States**

(12) **Patent Application Publication**  
**Slayton et al.**

(10) **Pub. No.: US 2017/0095680 A1**

(43) **Pub. Date: Apr. 6, 2017**

(54) **ENERGY BASED FAT REDUCTION**

**Publication Classification**

(71) Applicant: **Guided Therapy Systems, LLC**, Mesa, AZ (US)

(51) **Int. Cl.**  
*A61N 7/00* (2006.01)  
*G01S 7/52* (2006.01)  
*B06B 1/06* (2006.01)  
*G01S 15/89* (2006.01)  
*A61B 5/00* (2006.01)  
*A61B 8/08* (2006.01)

(72) Inventors: **Michael H. Slayton**, Tempe, AZ (US);  
**Peter G. Barthe**, Phoenix, AZ (US)

(21) Appl. No.: **15/380,267**

(52) **U.S. Cl.**  
 CPC ..... *A61N 7/00* (2013.01); *A61B 5/4869*  
 (2013.01); *A61B 8/0858* (2013.01); *B06B*  
*1/0607* (2013.01); *G01S 15/899* (2013.01);  
*G01S 7/5208* (2013.01); *A61N 2007/0008*  
 (2013.01); *A61N 2007/0052* (2013.01); *A61N*  
*2007/027* (2013.01)

(22) Filed: **Dec. 15, 2016**

**Related U.S. Application Data**

(63) Continuation of application No. 15/041,804, filed on Feb. 11, 2016, now Pat. No. 9,533,175, which is a continuation of application No. 14/550,772, filed on Nov. 21, 2014, now Pat. No. 9,283,409, which is a continuation of application No. 14/192,520, filed on Feb. 27, 2014, now Pat. No. 8,920,324, which is a continuation of application No. 12/646,609, filed on Dec. 23, 2009, now Pat. No. 8,663,112, which is a continuation-in-part of application No. 11/163,154, filed on Oct. 6, 2005, now Pat. No. 8,133,180.

(60) Provisional application No. 60/616,753, filed on Oct. 6, 2004, provisional application No. 61/140,725, filed on Dec. 24, 2008.

(57) **ABSTRACT**

Methods for non-invasive fat reduction can include targeting a region of interest below a surface of skin, which contains fat and delivering ultrasound energy to the region of interest. The ultrasound energy generates a thermal lesion with said ultrasound energy on a fat cell. The lesion can create an opening in the surface of the fat cell, which allows the draining of a fluid out of the fat cell and through the opening. In addition, by applying ultrasound energy to fat cells to increase the temperature to between 43 degrees and 49 degrees, cell apoptosis can be realized, thereby resulting in reduction of fat.

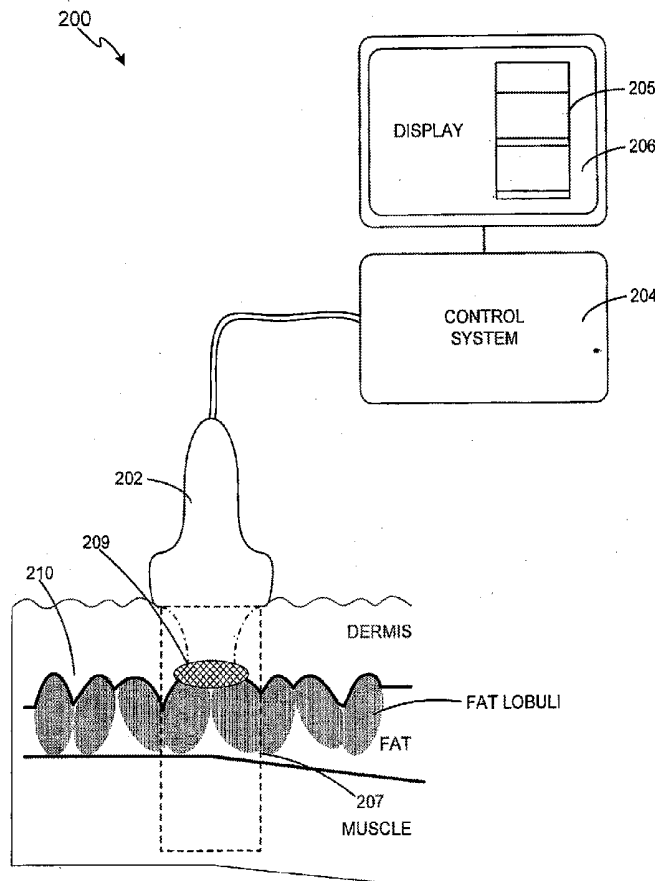

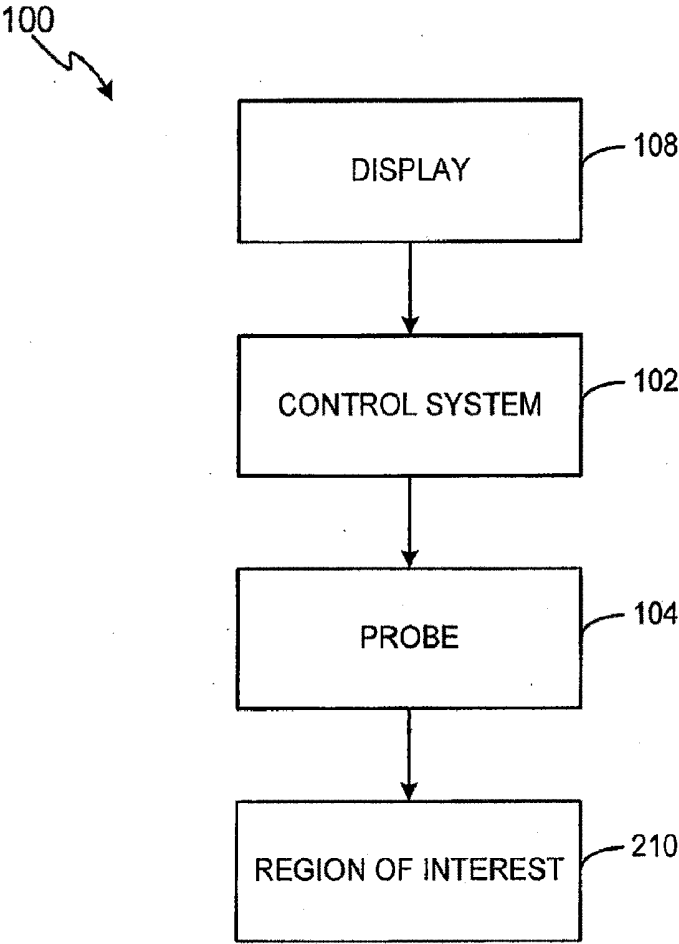

**FIG. 1**

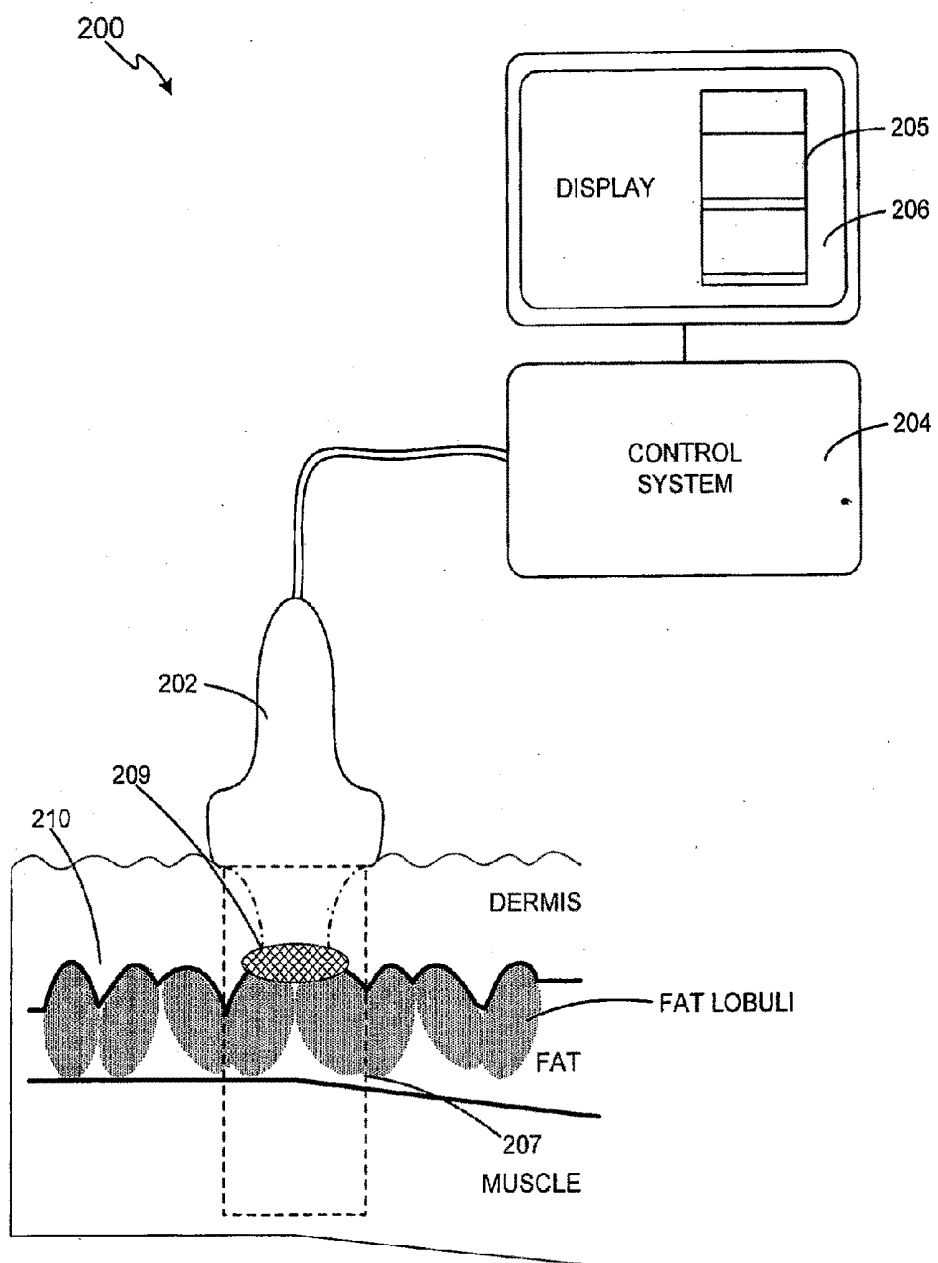

FIG. 2

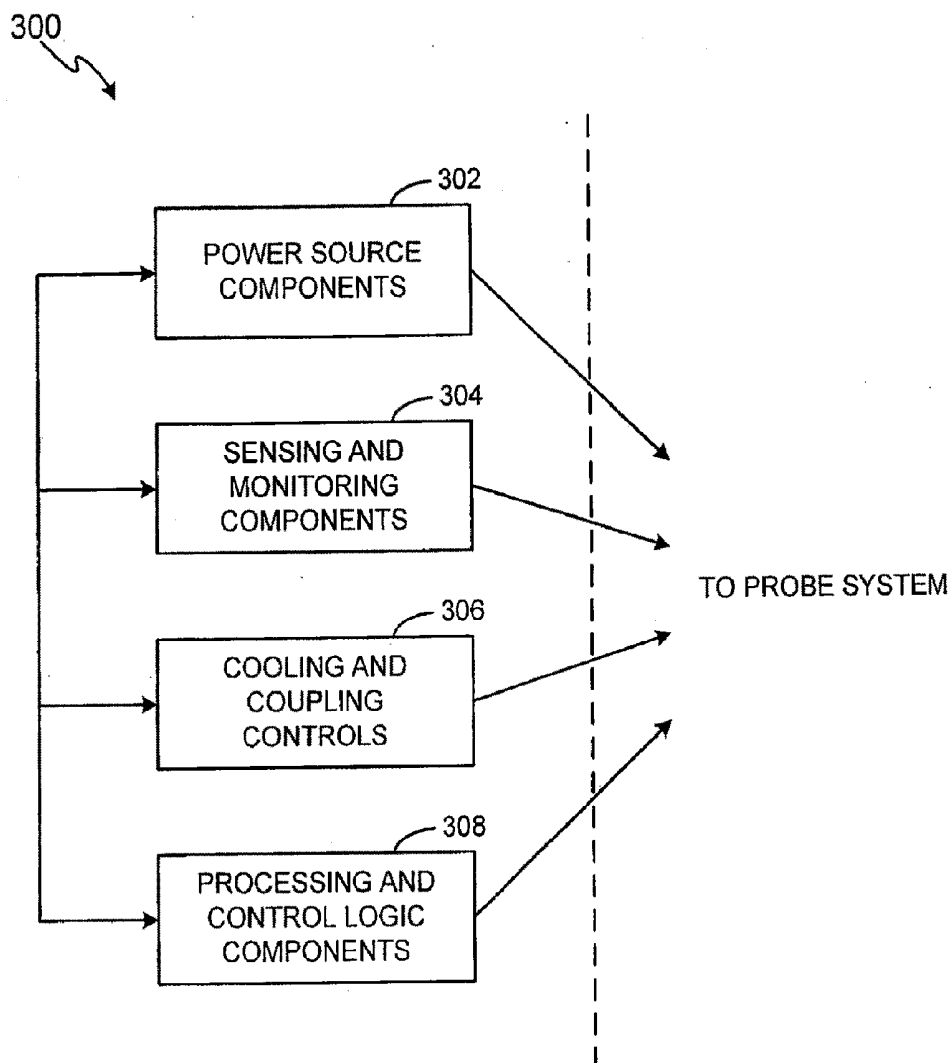
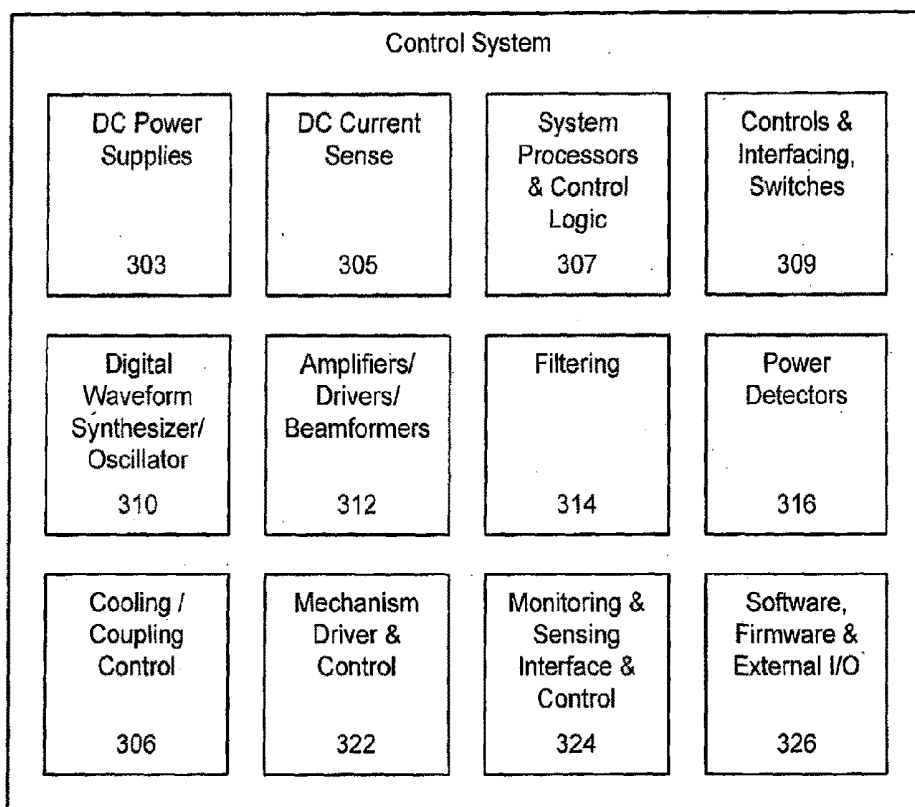

FIG. 3A

300 ↘



**FIG. 3B**

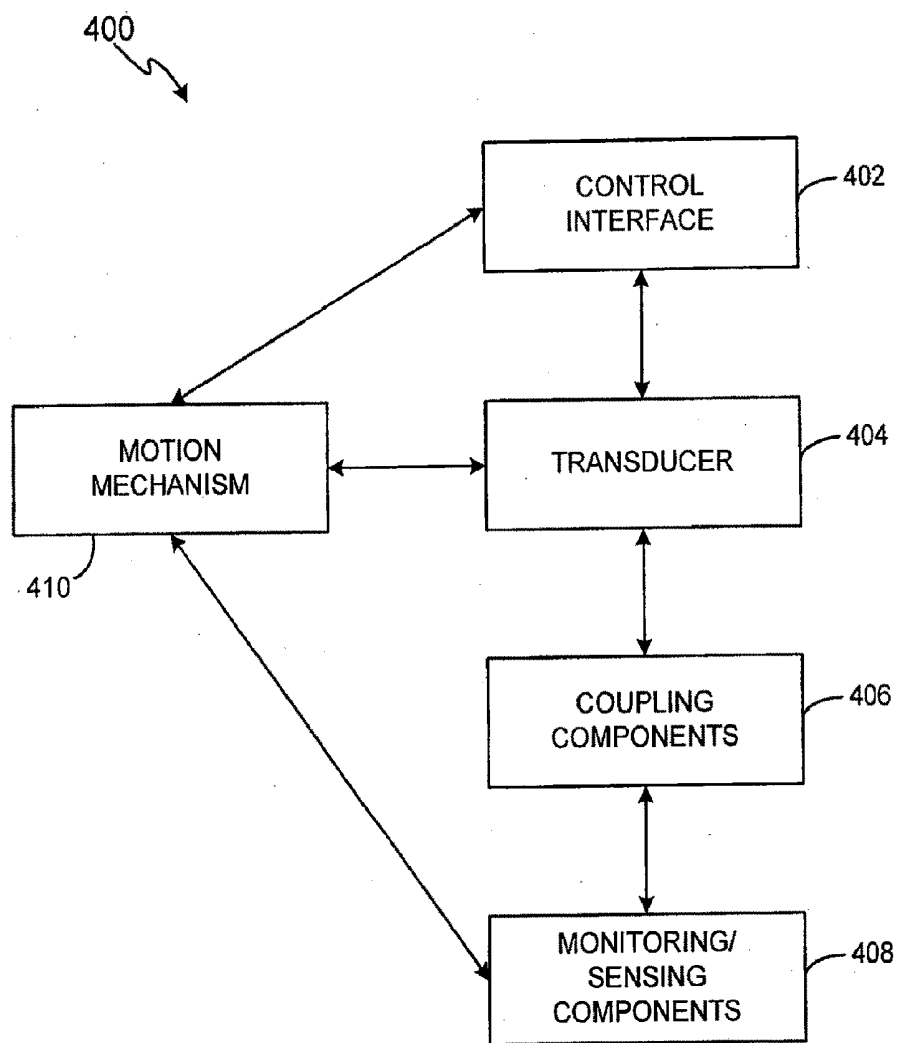

FIG. 4A

400 ↘

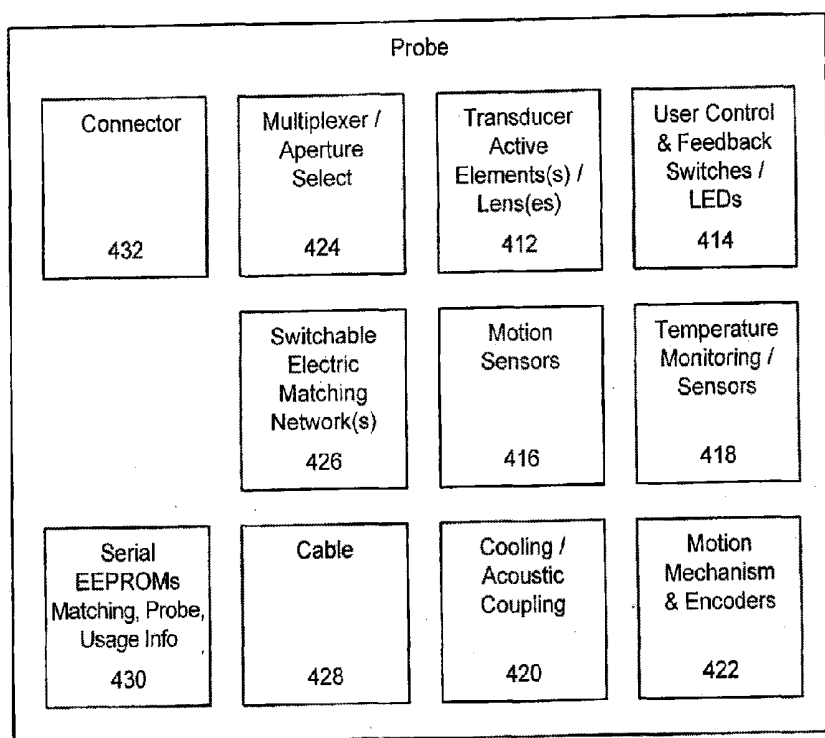

FIG. 4B

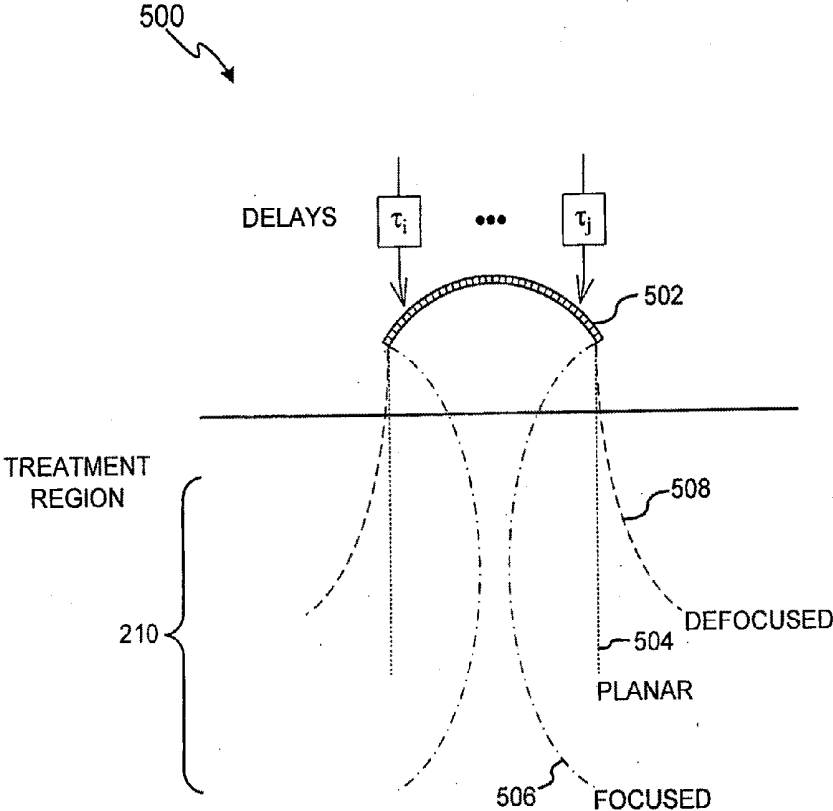

FIG. 5

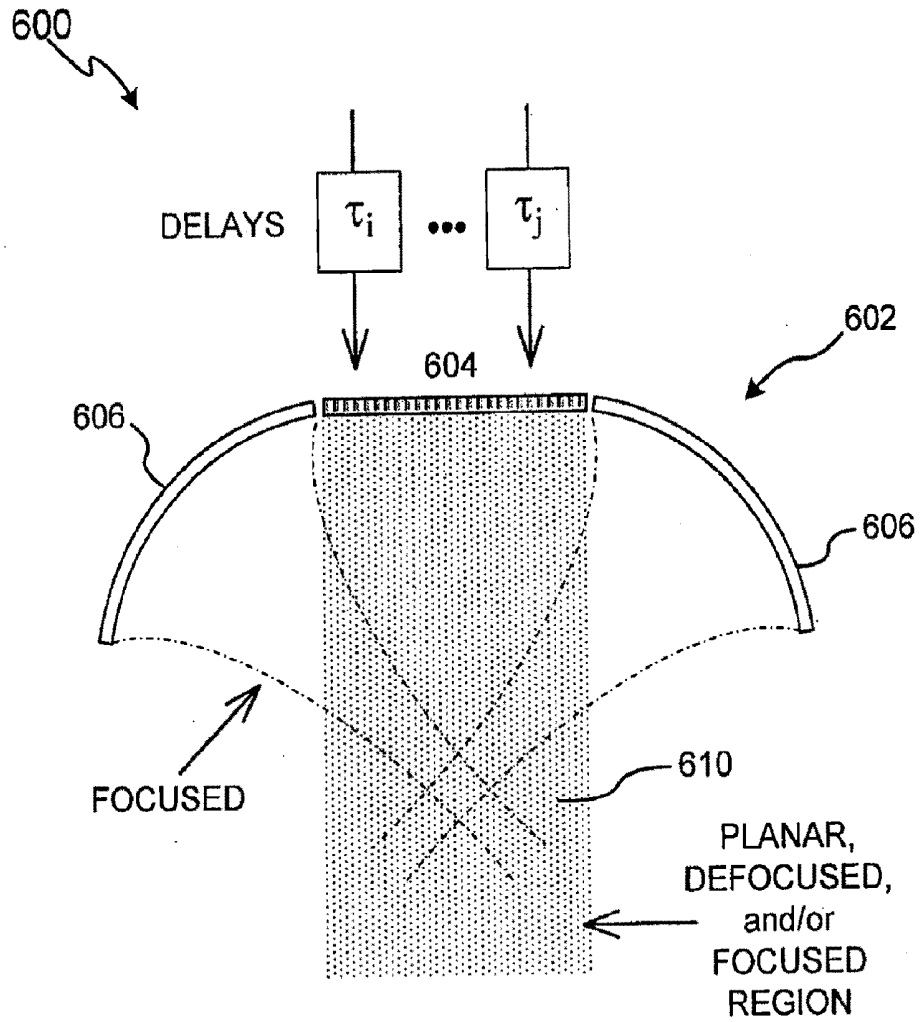
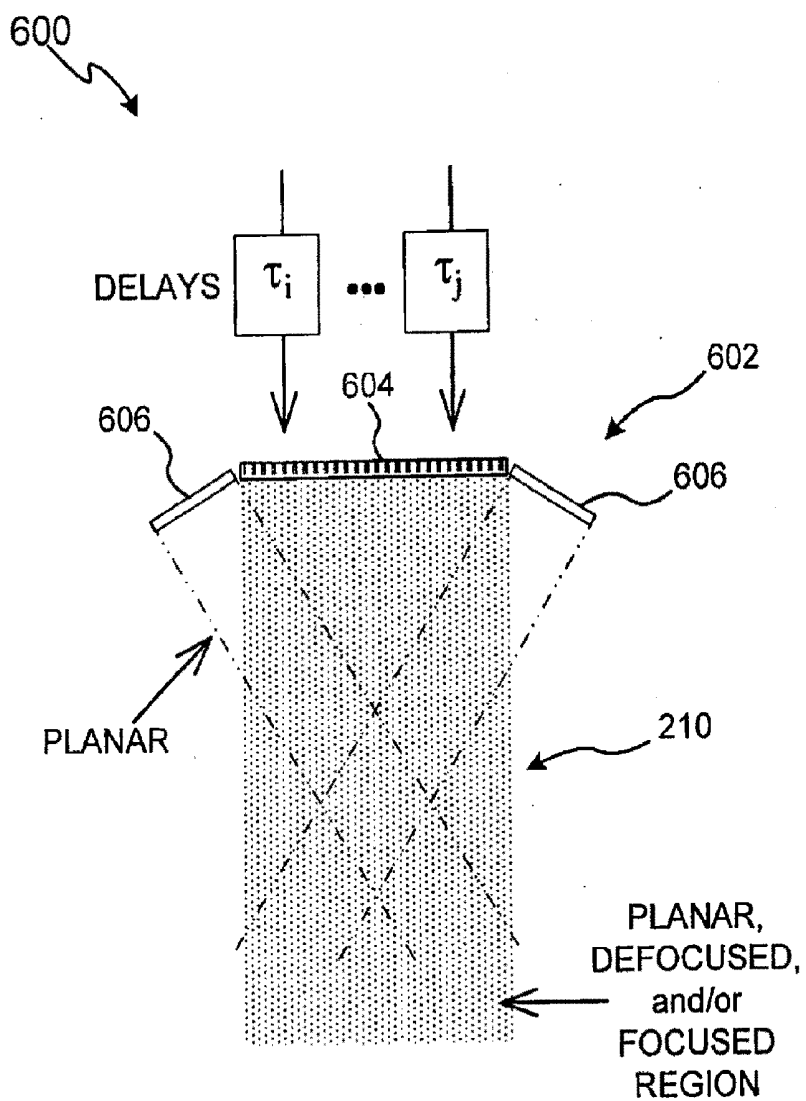

FIG. 6A



**FIG. 6B**

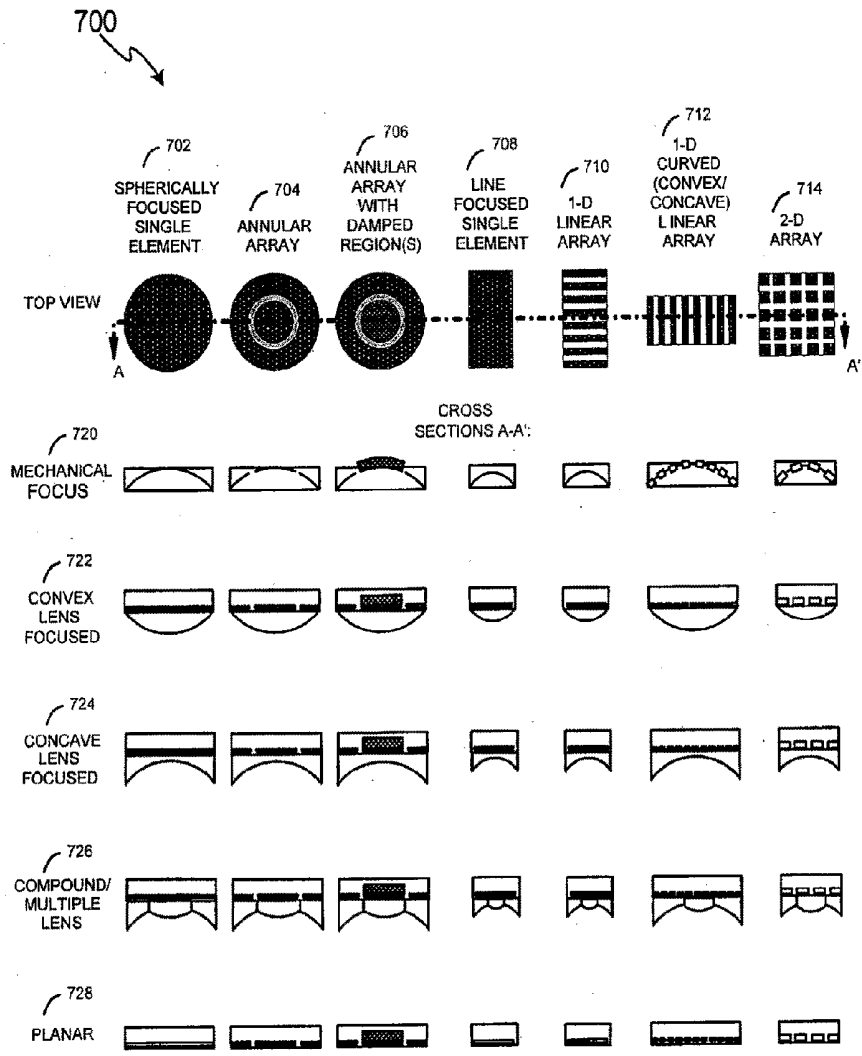

FIG. 7

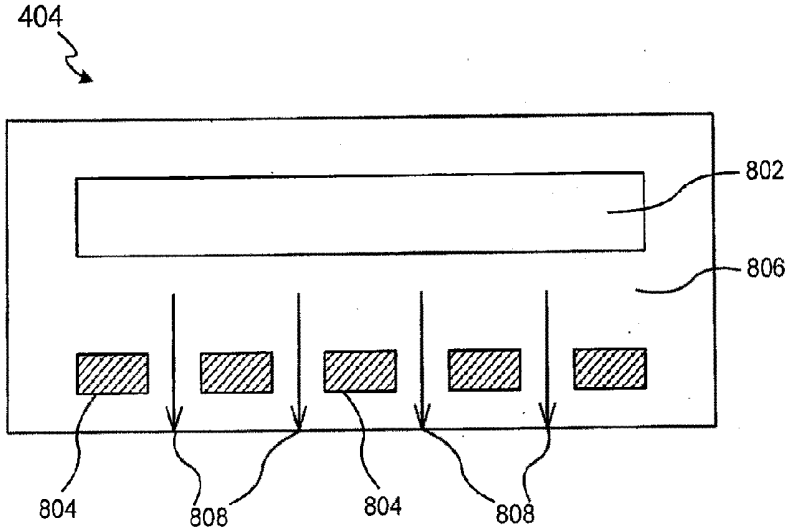

FIG. 8A

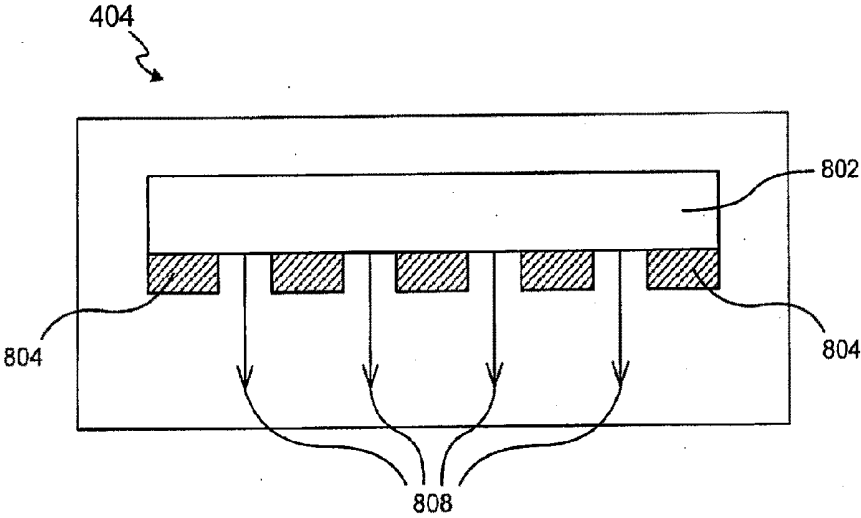

FIG. 8B

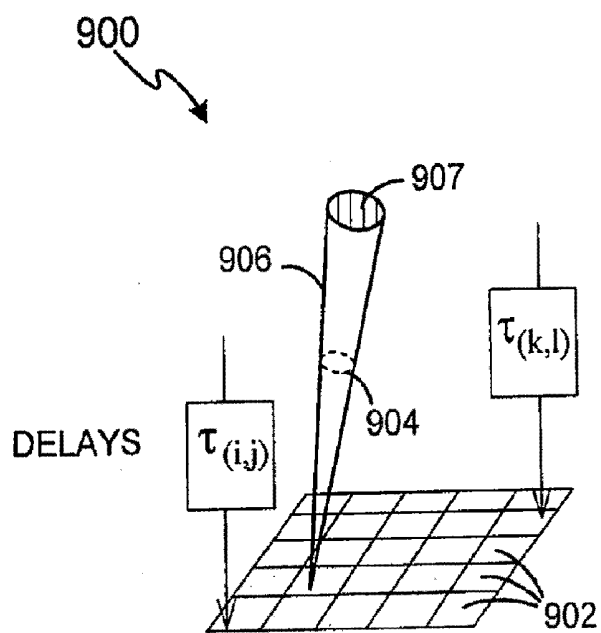

FIG. 9

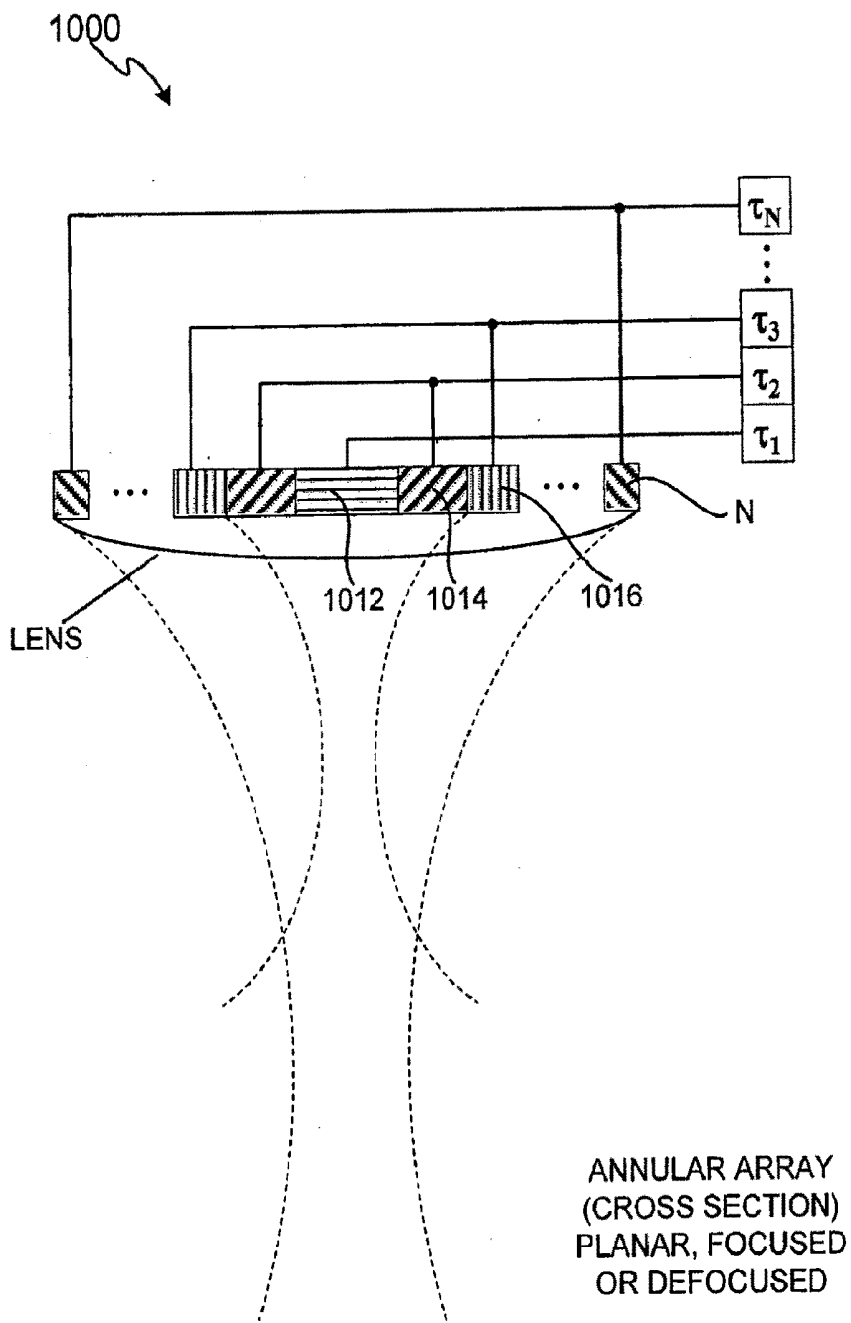
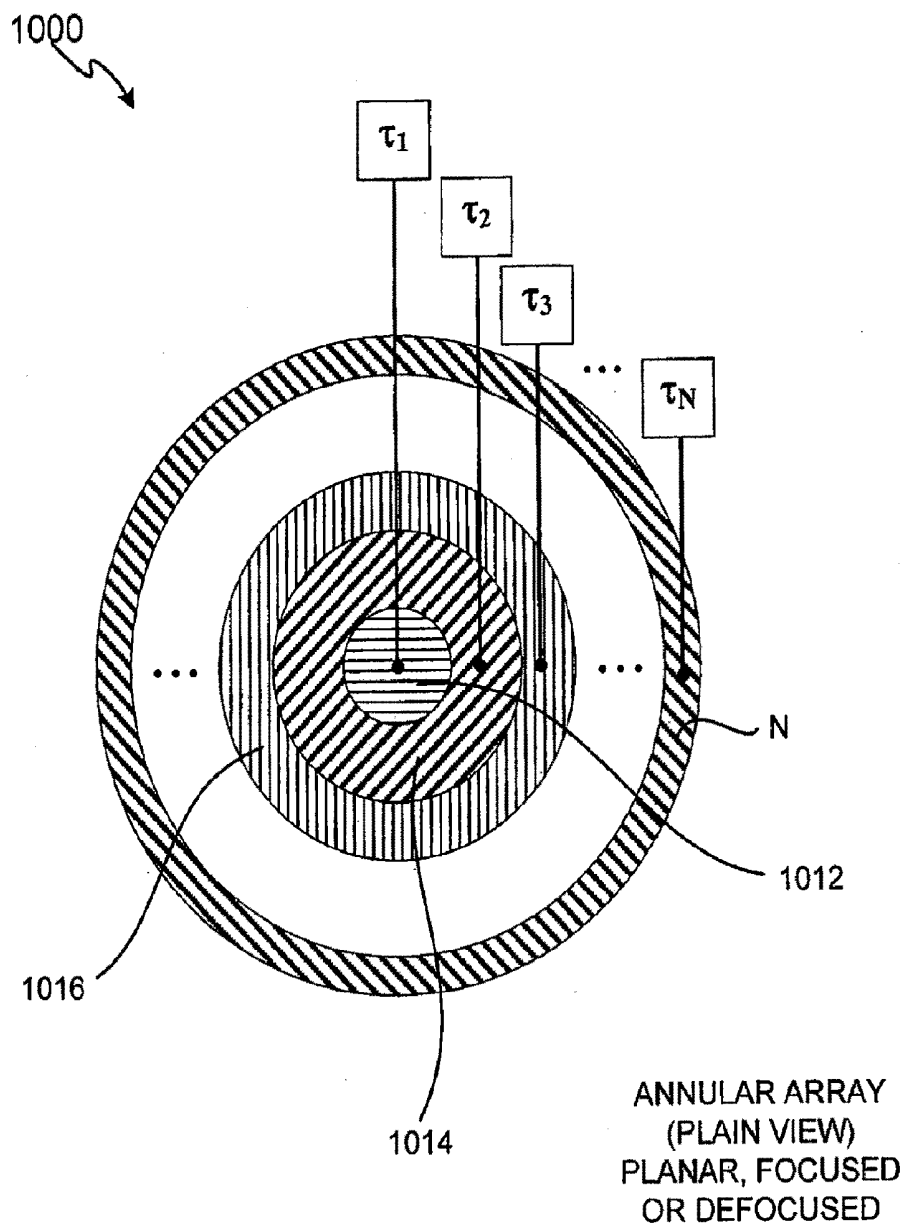

FIG. 10A



**FIG. 10B**

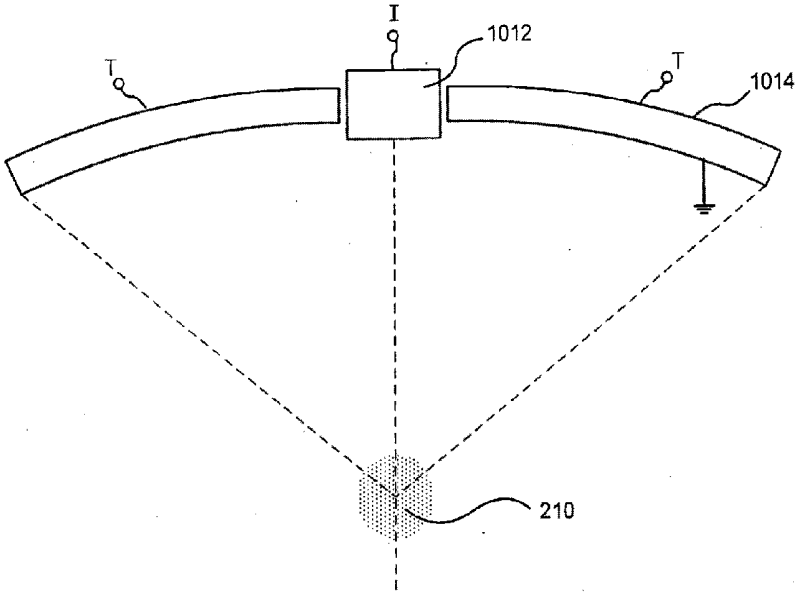

FIG. 10C

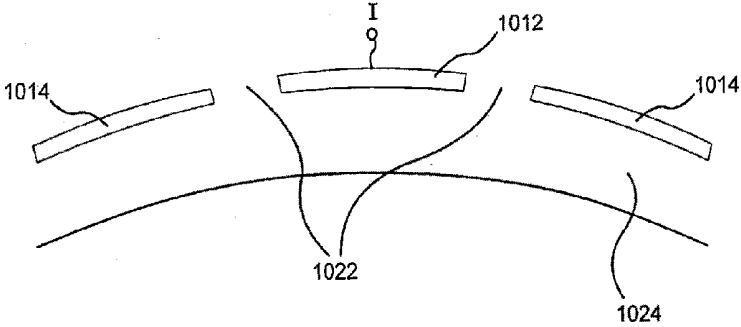

FIG. 10D

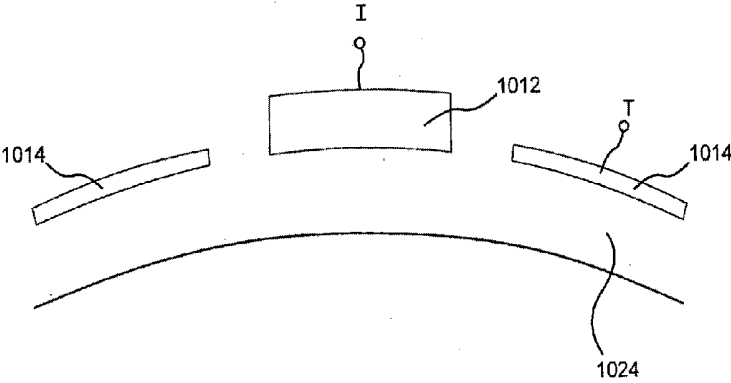

FIG. 10E

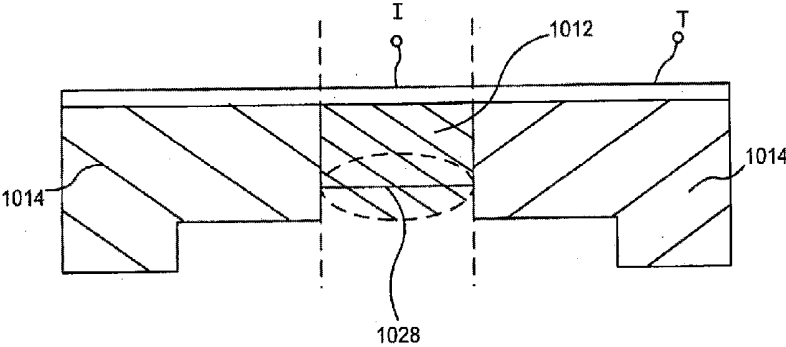

FIG. 10F

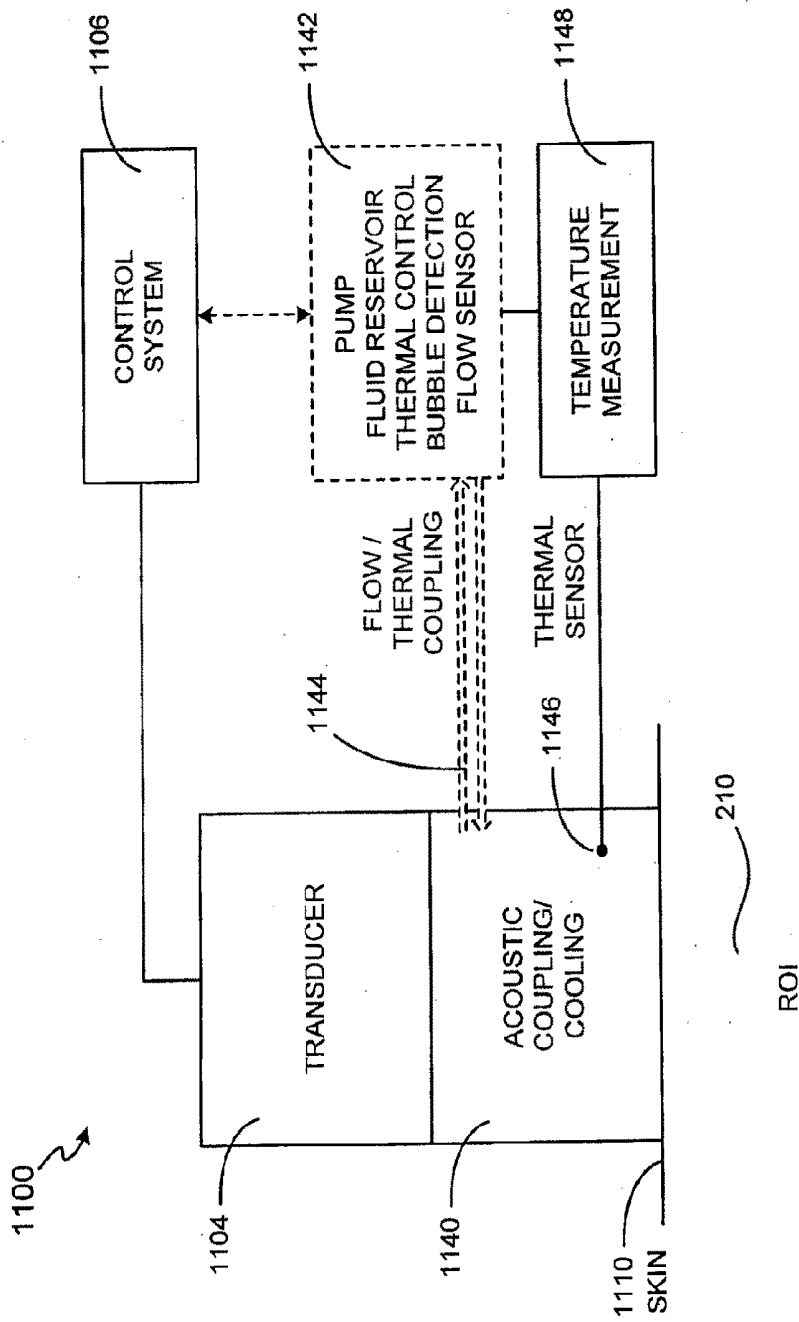

FIG. 11

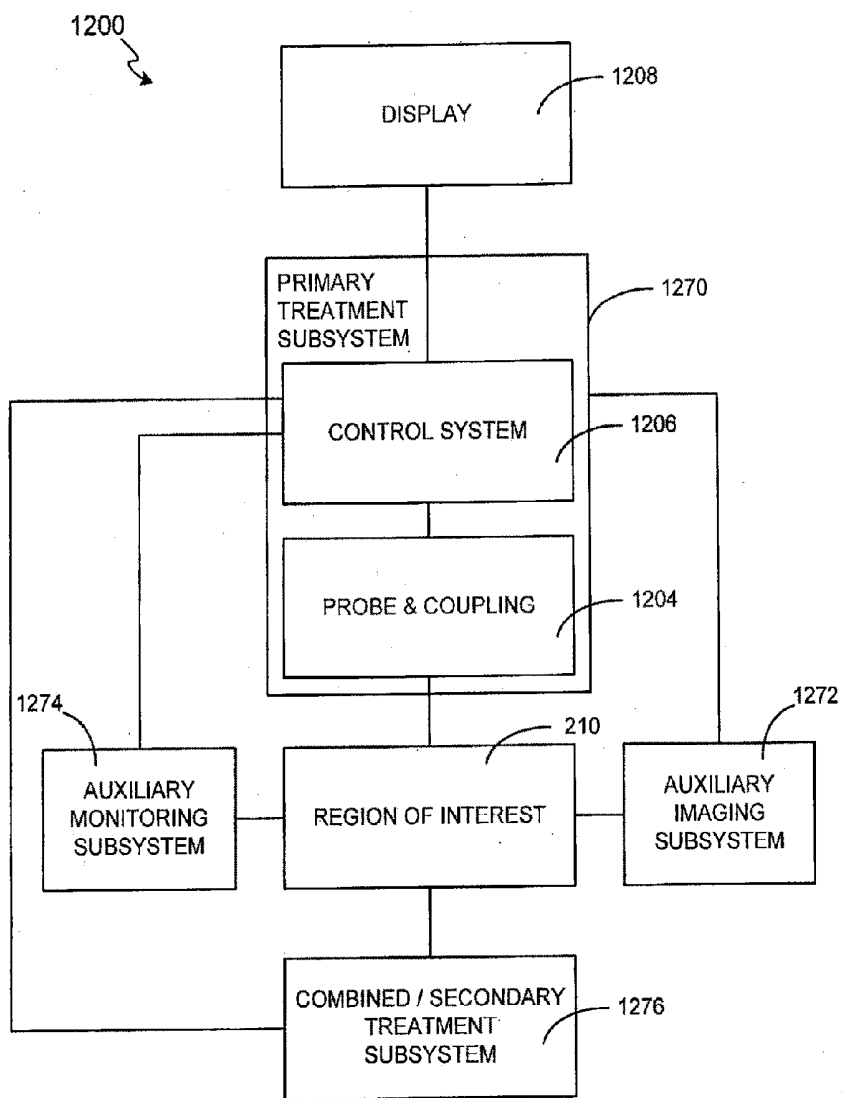

FIG. 12

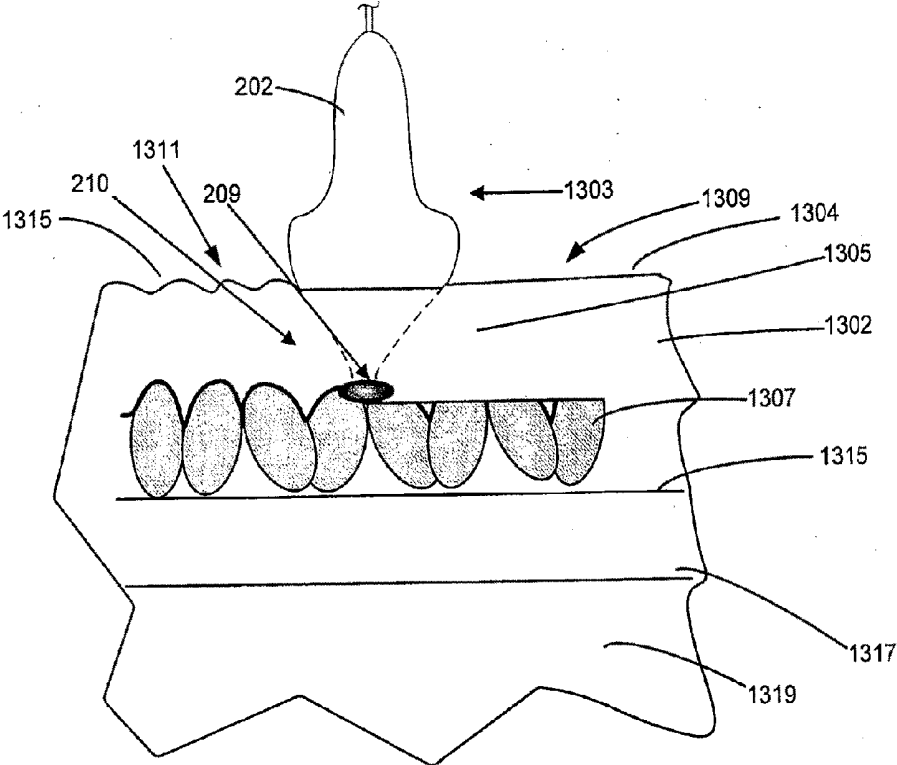

FIG. 13

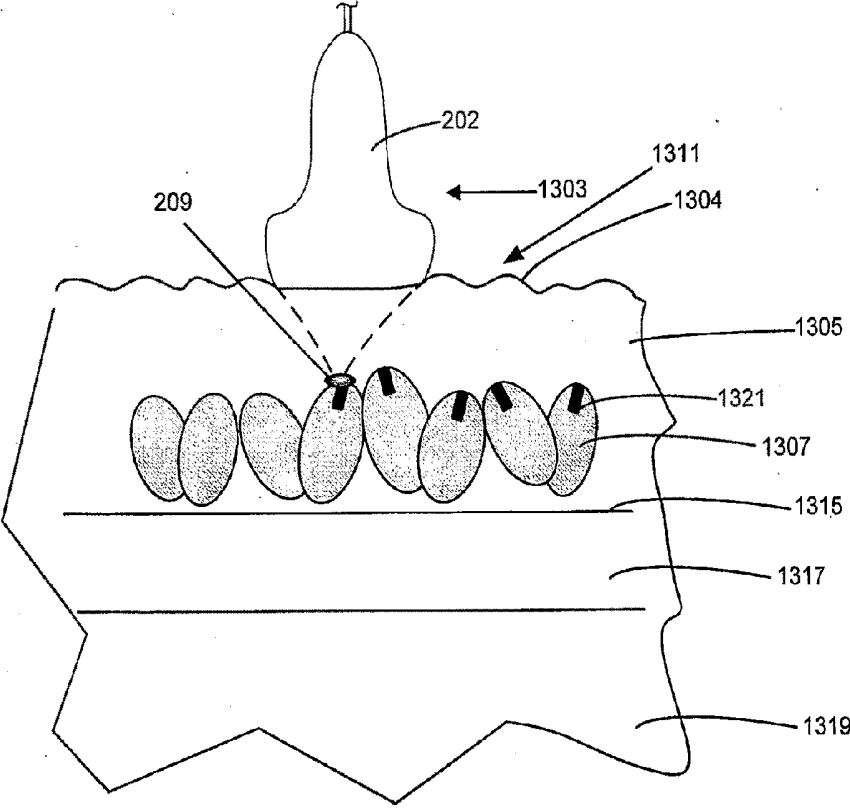

FIG. 14A

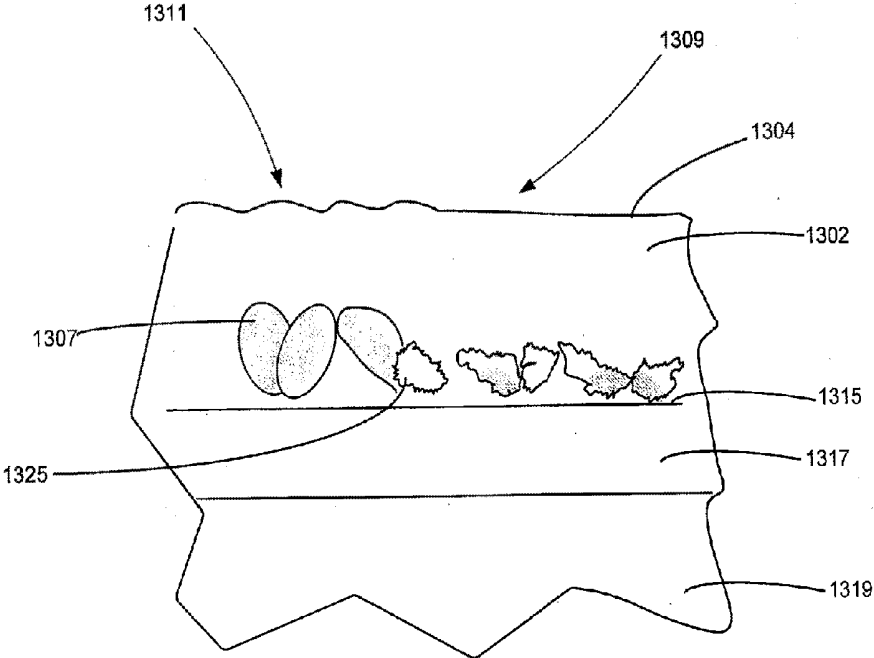

FIG. 14B

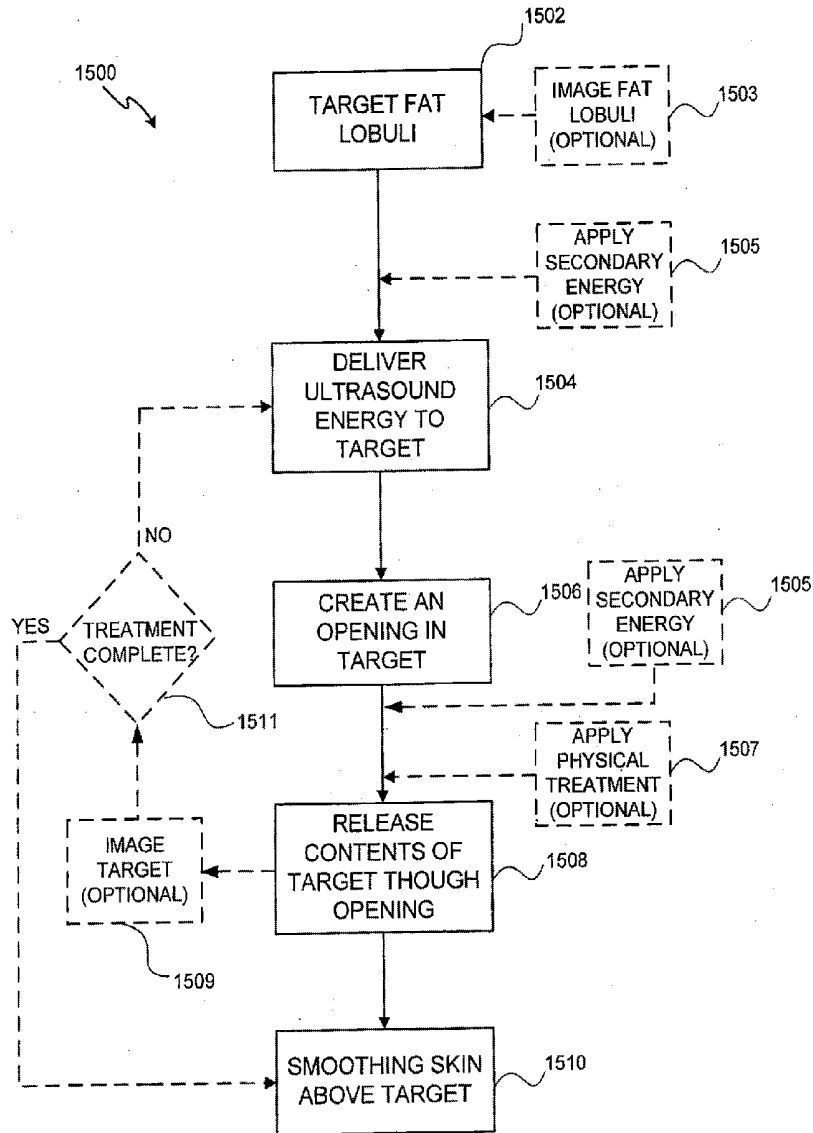

FIG. 15

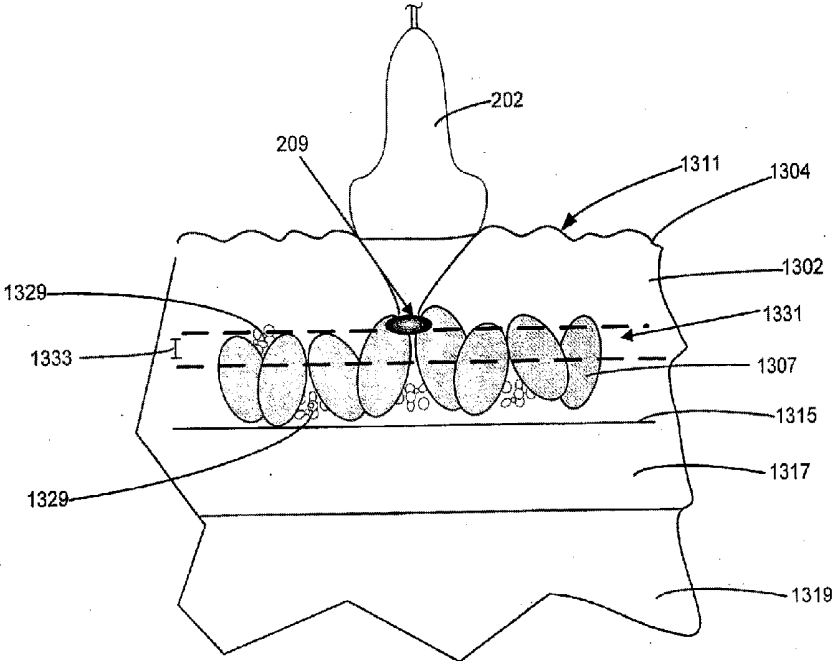

FIG. 16A

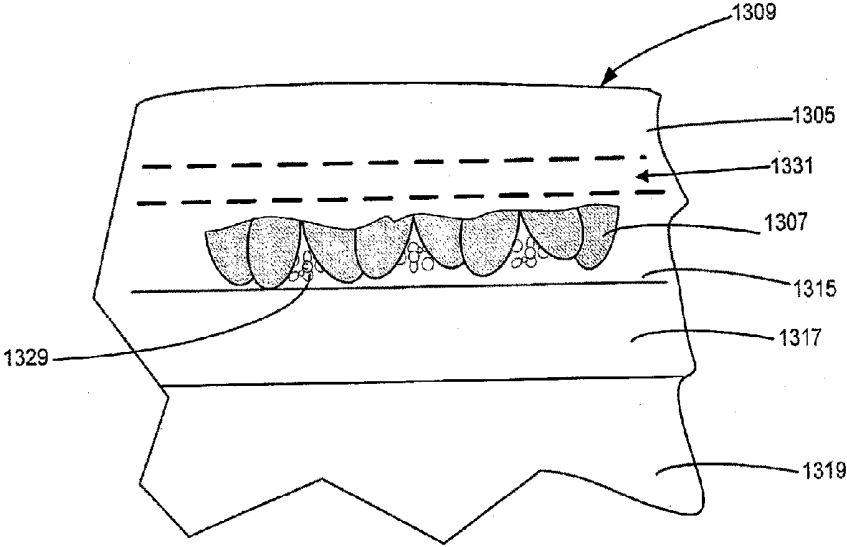

FIG. 16B

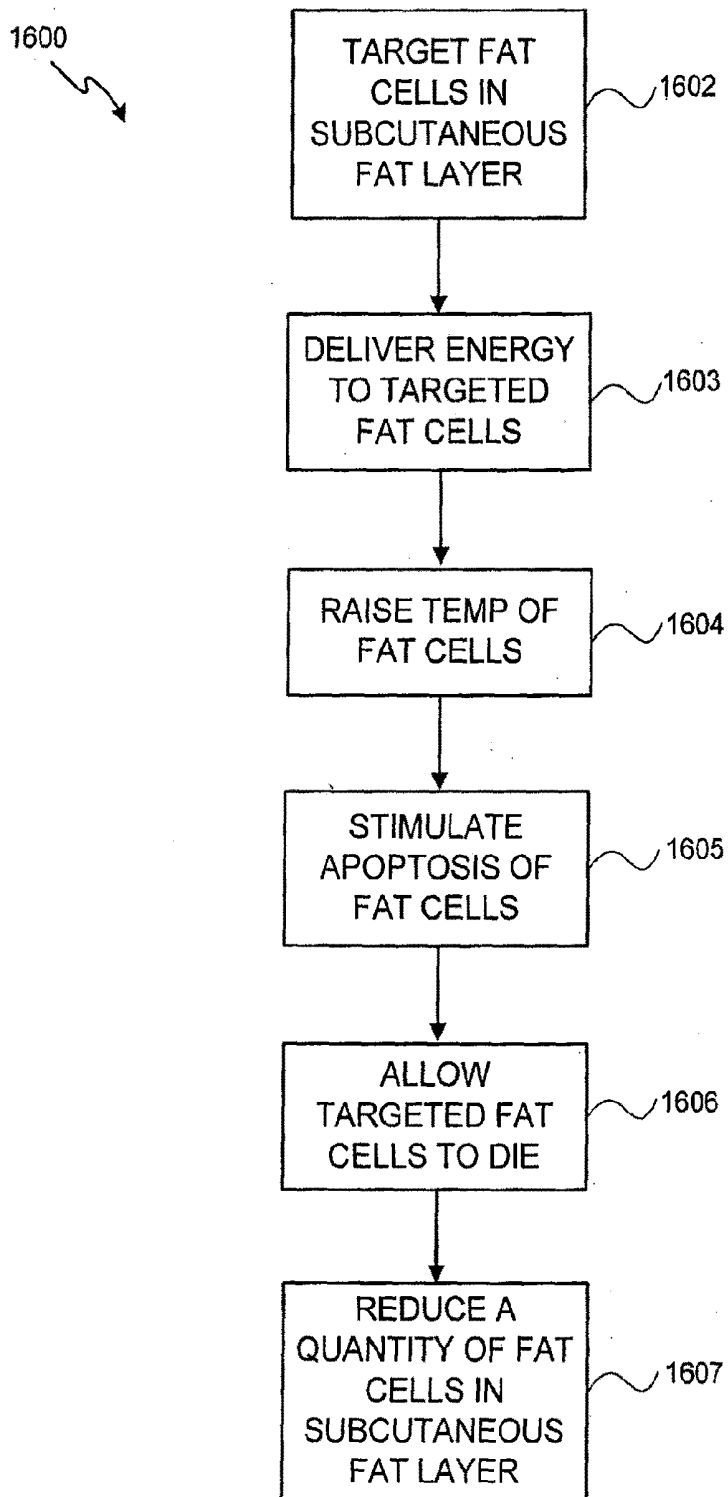

FIG. 17

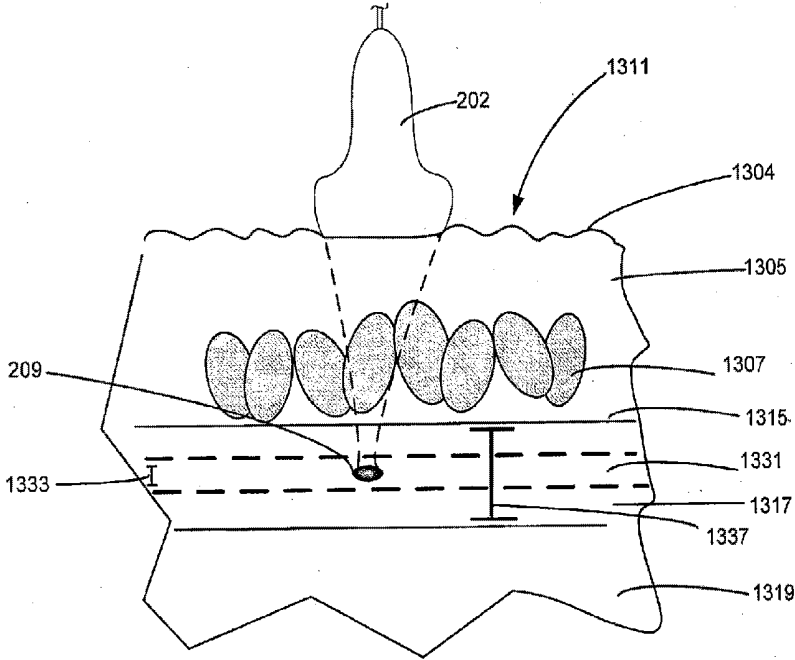

FIG. 18A

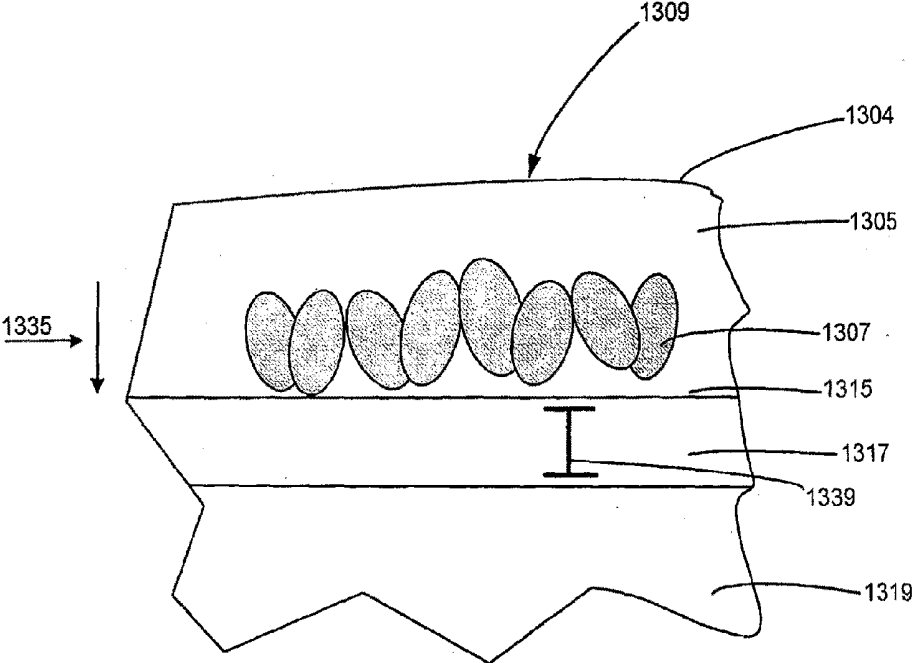

FIG. 18B

**ENERGY BASED FAT REDUCTION****CROSS-REFERENCE TO RELATED APPLICATIONS**

[0001] This application is a continuation of U.S. application Ser. No. 15/041,804, filed Feb. 11, 2016, now U.S. Pat. No. 9,533,175, which is a continuation of U.S. application Ser. No. 14/550,772, filed Nov. 21, 2014, now U.S. Pat. No. 9,283,409, which is a continuation of U.S. application Ser. No. 14/192,520 filed Feb. 27, 2014, now U.S. Pat. No. 8,920,324, which is a continuation of U.S. application Ser. No. 12/646,609 filed Dec. 23, 2009, now U.S. Pat. No. 8,663,112, which is a continuation-in-part of U.S. application Ser. No. 11/163,154 filed on Oct. 6, 2005, now U.S. Pat. No. 8,133,180, which claims the benefit of priority to U.S. Provisional No. 60/616,753 filed on Oct. 6, 2004, each of which are hereby incorporated by reference in their entirety herein. In addition, U.S. application Ser. No. 12/646,609, now U.S. Pat. No. 8,663,112, claims the benefit of priority from U.S. Provisional No. 61/140,725 filed on Dec. 24, 2008, which is hereby incorporated by reference in its entirety herein. Any and all priority claims identified in the Application Data Sheet, or any correction thereto, are hereby incorporated by reference under 37 CFR 1.57.

**BACKGROUND**

[0002] Field of the Invention

[0003] The present invention relates to ultrasound therapy systems, and in particular to methods and systems for treating cellulite or reducing fat.

[0004] Description of the Related Art

[0005] In general, cellulite refers to a common skin disorder which is characterized by a dimple appearance in a person's skin that may be found on the hips, thighs, and/or buttocks. Underneath the dermis and epidermis layers of the skin there are multiple layers of fat. Cellulite tends to develop in the subcutaneous fat layers, which is unique as compared to other fat layers because the subcutaneous fat can be structured into specific chambers surrounded by strands of linked tissue, which are known as fat lobuli. This appearance is much more common in women than in men because of differences in the way fat, muscle, and connective tissue are distributed in men's and women's skin. The lumpiness of cellulite is caused by the fat lobuli that push and distort the connective tissues beneath the skin; resulting protrusions and depressions of connective tissue anchor points create the appearance of cellulite.

[0006] Invasive treatments for cellulite include Iontophoresis, liposuction, and electrolipophoresis, which can involve an application of a low-frequency electric current. Non-invasive treatments for cellulite can include laser and suction massage combination therapy, pneumatic pressure massage therapy, lymphatic drainage massage, and low-frequency ultrasound diathermy. Such invasive and non-invasive treatments have yielded marginal results. In addition, a number of drugs that act on fatty tissue have been tried as therapeutic agents for cellulite treatment. Such drugs can be administered orally, applied topically as ointments, or by trans-dermal injection. At this point, no drug has been reported in the scientific literature as having a significant effect on cellulite. New developments for the treatment of cellulite are needed.

[0007] In addition, similar techniques have attempted to address the reduction of fat in humans, but such attempts have likewise had mixed results.

**SUMMARY**

[0008] In accordance with various aspects of the present invention, non-invasive methods and systems for fat reduction and/or treatment of cellulite are provided. In accordance with an exemplary embodiment, a non-invasive method for cellulite treatment can include targeting a region of interest below a surface of skin, which contains fat lobuli and delivering ultrasound energy to the region of interest. The ultrasound energy generates a conformal lesion with said ultrasound energy on a surface of a fat lobuli. The lesion creates an opening in the surface of the fat lobuli, which allows the draining of a fluid out of the fat lobuli and through the opening.

[0009] In accordance with an exemplary embodiment, a non-invasive method for cellulite treatment can include targeting fat cells in a subcutaneous fat layer and delivering ultrasound energy to raise the temperature of the fat cells, stimulating apoptosis of the fat cells and then allowing the targeted fat cells to die, thereby reducing a quantity of fat cells in the subcutaneous layer.

[0010] Further areas of applicability will become apparent from the description provided herein. It should be understood that the description and specific examples are intended for purposes of illustration only and are not intended to limit the scope of the present invention.

**BRIEF DESCRIPTION OF THE DRAWINGS**

[0011] The drawings described herein are for illustration purposes only and are not intended to limit the scope of the present disclosure in any way. The present invention will become more fully understood from the detailed description and the accompanying drawings wherein:

[0012] FIG. 1 illustrates a block diagram of an ultrasound treatment system for treating cellulite in accordance with exemplary embodiments of the present invention;

[0013] FIG. 2 illustrates a cross-sectional diagram of a transducer system in accordance with exemplary embodiments of the present invention;

[0014] FIGS. 3A and 3B illustrate block diagrams of an exemplary control system in accordance with exemplary embodiments of the present invention;

[0015] FIGS. 4A and 4B illustrate block diagrams of an exemplary probe system in accordance with exemplary embodiments of the present invention;

[0016] FIG. 5 illustrates a cross-sectional diagram of an exemplary transducer in accordance with exemplary embodiments of the present invention;

[0017] FIGS. 6A and 6B illustrate cross-sectional diagrams of an exemplary transducer in accordance with exemplary embodiments of the present invention;

[0018] FIG. 7 illustrates exemplary transducer configurations for ultrasound treatment in accordance with exemplary embodiments of the present invention;

[0019] FIGS. 8A and 8B illustrate cross-sectional diagrams of an exemplary transducer in accordance with exemplary embodiments of the present invention;

[0020] FIG. 9 illustrates an exemplary transducer configured as a two-dimensional array for ultrasound treatment in accordance with exemplary embodiments of the present invention;

[0021] FIGS. 10A-10F illustrate cross-sectional diagrams of exemplary transducers in accordance with exemplary embodiments of the present invention;

[0022] FIG. 11 illustrates a schematic diagram of an acoustic coupling and cooling system in accordance with exemplary embodiments of the present invention;

[0023] FIG. 12 illustrates a block diagram of a treatment system comprising an ultrasound treatment subsystem combined with additional subsystems and methods of treatment monitoring and/or treatment imaging as well as a secondary treatment subsystem in accordance with exemplary embodiments of the present invention;

[0024] FIG. 13 is a cross-sectional diagram illustrating a method of treating cellulite in accordance with exemplary embodiments of the present invention;

[0025] FIGS. 14A and 14B are cross-sectional diagrams illustrating another method of treating cellulite in accordance with exemplary embodiments of the present invention;

[0026] FIG. 15 is a block diagram illustrating a method of treating cellulite in accordance with exemplary embodiments of the present invention;

[0027] FIGS. 16A and 16B are cross-sectional diagrams illustrating a method of reducing fat and treating cellulite in accordance with exemplary embodiments of the present invention;

[0028] FIG. 17 is a block diagram illustrating a method of fat reduction in accordance with exemplary embodiments of the present invention; and

[0029] FIGS. 18A and 18B are cross-sectional diagrams illustrating a method of reducing fat in accordance with exemplary embodiments of the present invention.

#### DETAILED DESCRIPTION

[0030] The following description is merely exemplary in nature and is not intended to limit the present invention or its teachings, applications, or uses thereof. It should be understood that throughout the drawings, corresponding reference numerals indicate like or corresponding parts and features. The description of specific examples indicated in various embodiments and aspects of the present invention are intended for purposes of illustration only and are not intended to limit the scope of the invention disclosed herein. Moreover, recitation of multiple embodiments having stated features is not intended to exclude other embodiments having additional features or other embodiments incorporating different combinations of the stated features.

[0031] The present invention may be described herein in terms of various functional components and processing steps. It should be appreciated that such components and steps may be realized by any number of hardware components configured to perform the specified functions. For example, the present invention may employ various medical treatment devices, visual imaging and display devices, input terminals and the like, which may carry out a variety of functions under the control of one or more control systems or other control devices. In addition, the present invention may be practiced in any number of medical or cosmetic contexts and the exemplary embodiments relating to a non-invasive methods and systems for fat reduction and/or

cellulite treatment as described herein are merely indicative of exemplary applications for the invention. For example, various of the principles, features and methods discussed herein may be applied to any medical or cosmetic application, or other

#### related applications

[0032] Various aspects of the present invention provide a method of non-invasive treatment of cellulite. The method includes targeting a region of interest below a surface of skin, which contains fat lobuli and delivering ultrasound energy to the region of interest. The ultrasound energy generates a conformal lesion within the ultrasound energy on a surface of a fat lobuli, such as, for example, by creating a sharp focal of ultrasound energy onto the fat lobuli. The lesion creates an opening in the surface of the fat lobuli, such as, for example, by piercing the fat lobuli, which allows the draining of a fluid out of the fat lobuli through the opening.

[0033] Various aspects of the present invention can also provide a method for fat reduction that can include heating a region of interest to a temperature in a range from about 43° C. to about 49° C., which can stimulate apoptosis of at least one fat cell in the fat lobuli. Still further, the method can include applying a physical treatment to said surface of skin and such physical treatment can include mesotherapy, iontophoresis, pressotherapy, pneumatic massage, lymphatic drainage, electrolipophoresis, roller massage, low frequency ultrasound, vacuum suction, laser energy, and application of RF energy. The physical treatment can be before, after, or concurrent with the delivery of the ultrasound energy. The method can include the use of a second energy, which can be used before, after, or concurrent with the delivery of the ultrasound energy. The method can reduce the appearance of cellulite on the surface of skin.

[0034] Various aspects of the present invention provide a method of non-invasively stimulating apoptosis of a fat cell located in a subcutaneous fat layer. The method include targeting at least one fat cell in a subcutaneous layer below a skin surface and delivering energy to the fat cell. The delivered energy raises a temperature of the fat cell into a range from about 43° C. to about 49° C., which stimulates apoptosis of the fat cell.

[0035] The method can further include imaging of the fat cell. Still further, the method can include generating a conformal lesion into said at least one fat cell, which can create an opening in the fat cell and allow the moving of a material out of the fat cell through the opening. The energy is typically ultrasound energy in the range of about 750 kHz to about 20 MHz or in a range from about 2 MHz to about 20 MHz, or other more specific ranges. Still further the method can include applying a physical treatment to said surface of skin and such physical treatment can include mesotherapy, iontophoresis, pressotherapy, pneumatic massage, lymphatic drainage, electrolipophoresis, roller massage, low-frequency ultrasound, vacuum suction, laser energy, and application of RF energy. The physical treatment can be before, after, or concurrent with the delivery of the energy. The method can include the use of a second energy, which can be used before, after, or concurrent with the delivery of the energy. The method can reduce the number of fat cells in the subcutaneous fat layer.

[0036] In addition, various aspects of the present invention provide a method that combines fat reduction and cellulite reduction. The method includes targeting a region of interest

below a surface of skin, which contains fat lobuli, and delivering ultrasound energy to the region of interest. The ultrasound energy generates a conformal lesion with said ultrasound energy on a surface of a fat lobuli. The lesion creates an opening in the surface of the fat lobuli, which allows the draining of a fluid out of the fat lobuli through the opening. Additionally, the method can include targeting at least one fat cell in a subcutaneous layer below a skin surface and delivering a second energy to the fat cell. The delivered second energy raises a temperature of the fat cell into a range from about 43° C. to about 49° C., which stimulates apoptosis of the fat cell.

**[0037]** The method can further include a physical treatment as described herein, as well as the use of a secondary energy source. The method can both reduce the number of fat cells in the subcutaneous fat layer and reduce the appearance of cellulite on a skin surface. The method can be effective in physically breaking fat cell clusters and stretching fibrous bonds of cellulite.

**[0038]** In accordance with an exemplary embodiment, a method of non-invasive treatment of cellulite can include targeting a region of interest below a skin surface, which contains fat lobuli, and delivering ultrasound energy at a specified depth below the skin surface. The method further includes moving a source of the energy along the skin surface and ablating a portion of the fat lobuli at the specified depth below the skin surface.

**[0039]** In accordance with the exemplary method, a specified depth is generally in the range of about 1 mm to about 35 mm below the skin surface. The method can include applying a physical treatment as described herein. The method can smooth the skin surface and may reduce the appearance of cellulite on the skin surface. The method can further include any of the additional method steps discussed herein.

**[0040]** In accordance with various aspects of the present invention, non-invasive methods and systems for the reduction of fat and/or the treating of cellulite are provided. For example, in accordance with an exemplary embodiment, with reference to FIG. 1, an exemplary treatment system **100** configured to treat a region of interest **106** comprises a control system **102**, an imaging/therapy probe with acoustic coupling **104**, and a display system **108**.

**[0041]** Control system **102** and display system **108** can comprise various configurations for controlling probe **104** and overall system **100** functionality. In various embodiments, control system **102** can include, for example but not limited to any of the following, a microprocessor with software and a plurality of input/output devices, systems or devices for controlling electronic and/or mechanical scanning and/or multiplexing of transducers, systems for power delivery, systems for monitoring, systems for sensing the spatial position of the probe and/or transducers, and/or systems for handling user input and recording treatment results, among others. Imaging/therapy probe **104** can comprise various probe and/or transducer configurations. For example, probe **104** can be configured for a combined dual-mode imaging/therapy transducer, coupled or co-housed imaging/therapy transducers, or simply a separate therapy probe and an imaging probe.

**[0042]** In accordance with an exemplary embodiment, treatment system **100** is configured for treating a deep tissue region that contains a lower part of dermis and proximal protrusions of fat lobuli into the dermis by, first, imaging

region of interest (“ROI”) **210** for localization of the treatment area and surrounding structures, second, delivering ultrasound energy at a depth, distribution, timing, and energy level to achieve the desired therapeutic effect, and third monitoring the treatment area before, during, and after therapy to plan and assess the results and/or provide feedback. As to the delivery of energy, control system **102** and transducer system **102** can be suitably configured to deliver conformal ultrasound therapeutic energy to ROI **210** creating a thermal injury and coagulating the proximal protrusions of fat lobuli, thereby eliminating the fat protrusions into the dermis. As used herein, the term “dermis” refers to any part of the dermis and/or the epidermis.

**[0043]** Because the location and thickness of the fat lobuli varies from one patient to another (due to genetics, weight, age, etc.), imaging using a transducer can facilitate treatment within a patient, however imaging is not required to treat cellulite.

**[0044]** By planning a treatment protocol, the user may choose one or more spatial and/or temporal characteristics to provide conformal ultrasound energy to ROI **210**. For example, the user may select one or more spatial characteristics to control, including, for example, the use of one or more transducers, one or more mechanical and/or electronic focusing mechanisms, one or more transduction elements, one or more placement locations of the transducer relative to ROI **210**, one or more feedback systems, one or more mechanical arms, one or more orientations of the transducer, one or more temperatures of treatment, one or more coupling mechanisms and/or the like.

**[0045]** In addition, the user may choose one or more temporal characteristics to control in order to facilitate treatment of ROI **210**. For example, the user may select and/or vary the treatment time, frequency, power, energy, amplitude and/or the like in order to facilitate temporal control. For more information on selecting and controlling ultrasound spatial and temporal characteristics, see U.S. application Ser. No. 11/163,148, entitled “Method and System for Controlled Thermal Injury”, filed Oct. 6, 2005, published on Jun. 1, 2006 as U.S. Patent Application Publication No. 20060116671, and incorporated herein by reference.

**[0046]** After planning of a treatment protocol is complete, the treatment protocol can be implemented. That is, a transducer system can be used to deliver ultrasound energy to a treatment region to ablate select tissue in order to facilitate cellulite treatment. By delivering energy, the transducer may be driven at a select frequency, a phased array may be driven with certain temporal and/or spatial distributions, a transducer may be configured with one or more transduction elements to provide focused, defocused and/or planar energy, and/or the transducer may be configured and/or driven in any other ways hereinafter devised.

**[0047]** For treatment of ROI **210**, transducer system **102** may be configured to deliver one or more energy fields to promote one or more effects, for example, ablation of existing tissue, the breaking up of fat cell clusters, stretching of the fibrous bonds, enhancement of lymphatic drainage, stimulation of the evacuation of fat decay products, and/or enhanced cell permeability in order to treat cellulite. Additionally, for treatment of ROI **210**, transducer system **102** may be configured to deliver one or more energy fields to promote one or more effects, for example cell apoptosis, piercing cells to promote drainage, and ablating a layer of fat

cells to a specified distance below a skin surface, such as for example giving the fat cells a haircut. Of course transducer system may be configured to deliver one energy field as needed by any of the methods of treatment described herein. As described herein, imaging is not necessary for treatment methods or treatment plans but rather is an optional step. For example, the dimpled pattern of cellulite is typically visible on the surface of a patient's skin and the system user can easily identify ROI 210 that will be treated.

[0048] Through operation of treatment system 100, a method for treatment of cellulite can be realized that can facilitate effective and efficient therapy without creating chronic injury to human tissue. For example, a user may first select one or more transducer probe configurations for treating ROI 210. The user may select any probe configuration described herein. Because the treatment region ranges from about 0 mm to greater than about 5.5 cm or from about 1 mm to about 3.5 cm, exemplary transducer probes may include, for example, an annular array, a variable depth transducer, a mechanically moveable transducer, a cylindrical-shaped transducer, a linear or flat transducer and the like. As used herein, the term user may include a person, employee, doctor, nurse, and/or technician, utilizing any hardware and/or software of other control systems.

[0049] Once one or more transducers are selected, the user may then image ROI 210 in order to plan a treatment protocol. By imaging ROI 210, the user may use the same treatment transducer probe and/or one or more additional transducers to image ROI 210 at a high resolution. In one embodiment, the transducer may be configured to facilitate high speed imaging over a large ROI 210 to enable accurate imaging over a large ROI 210. In another embodiment, ultrasound imaging may include, individually or in combination, the use of Doppler flow monitoring and/or color flow monitoring. In addition, other means of imaging such as photography and other visual optical methods, MRI, X-Ray, PET, infrared or others can be utilized separately or in combination for imaging and feedback of the superficial tissue and the vascular tissue in ROI 210.

[0050] An exemplary ultrasound therapy system of FIG. 1 is further illustrated in an exemplary embodiment in FIG. 2. A therapy transducer system 200 includes a transducer probe 202 connected to control system 204, and display 206, in combination may provide therapy, imaging, and/or temperature or other tissue parameters monitoring to ROI 210. Exemplary transducer system 200 is configured for, first, imaging and display of ROI 210 for localization of the treatment area and surrounding structures, second, delivery of focused, unfocused, or defocused ultrasound energy at a depth, distribution, timing, and energy level to achieve the desired therapeutic effect of thermal ablation to treat cellulite, and, third, to monitor the treatment area and surrounding structures before, during, and after therapy to plan and assess the results and/or provide feedback to control system 204 and/or an operator.

[0051] Exemplary transducer probe 202 can be configured to be suitably controlled and/or operated in various manners. For example, transducer probe 202 may be configured for use within an ultrasound treatment system, an ultrasound imaging system and/or an ultrasound imaging, therapy, and/or treatment monitoring system, including motion control subsystems.

[0052] Control system 204 can be configured with one or more subsystems, processors, input devices, displays and/or

the like. Display 206 may be configured to image and/or monitor ROI 210 and/or any particular sub-region within ROI 210. Display 206 can be configured for two-dimensional, three-dimensional, real-time, analog, digital and/or any other type of imaging. Exemplary embodiments of both control system 204 and display 206 are described in greater detail herein.

[0053] ROI 210, can be comprised of superficial layer (epidermis/dermis) subcutaneous fat, lobuli, and muscle. Exemplary transducer system 200 is configured to provide cross-sectional two-dimensional imaging of the region 207, displayed as an image 205, with a controlled thermal lesion 209, confined approximately to proximal portion of fat lobuli and lower portion of dermis.

[0054] Transducer system 200 can be configured with the ability to controllably produce conformal treatment areas in superficial human tissue within ROI 210 through precise spatial and temporal control of acoustic energy deposition. In accordance with an exemplary embodiment, control system 204 and transducer probe 202 can be suitably configured for spatial control of the acoustic energy by controlling the manner of distribution of the acoustical energy. For example, spatial control may be realized through selection of the type of one or more transducer configurations insomifying ROI 210, selection of the placement and location of transducer probe 202 for delivery of acoustical energy relative to ROI 210, e.g., transducer probe 202 configured for scanning over part or whole of ROI 210 to deliver conformal ultrasound therapeutic energy to create a thermal injury, such as a lesion, and to coagulate the proximal protrusions of fat lobuli, thereby eliminating the fat protrusions into the dermis. Transducer probe 202 may also be configured for control of other environment parameters, e.g., the temperature at the acoustic coupling interface can be controlled. In addition to the spatial control, control system 204 and/or transducer probe 202 can also be configured for temporal control, such as through adjustment and optimization of drive amplitude levels, frequency/waveform selections, and timing sequences and other energy drive characteristics to control the treatment of tissue. The spatial and/or temporal control can also be facilitated through open-loop and closed-loop feedback arrangements, such as through the monitoring of various positional and temporal characteristics. For example, through such spatial and/or temporal control, an exemplary treatment system 200 can enable the regions of thermal injury to possess arbitrary shape and size and allow the tissue to be treated in a controlled manner.

[0055] Transducer system 200 may be used to provide a mechanical action of ultrasound to physically break fat cell clusters and stretch the fibrous bonds. This mechanical action will also enhance lymphatic drainage, stimulating the evacuation of fat decay products. That is, the ultrasound may facilitate movement of the muscles and soft tissues within ROI 210, thereby facilitating the loosening of fat deposits and/or the break up of fibrous tissue surrounding fat deposits.

[0056] In addition, transducer system 200 can be configured to deliver various therapeutic levels of ultrasound to increase the speed at which fat metabolizes, according to Arrhenius' Law:  $K=Ae^{sup.-B/T}$ , where K is the kinetic rate of fat metabolism, A is a constant, B is the activation energy, and T is the temperature in degrees Kelvin. According to Arrhenius' Law, a metabolic reaction is a function of temperature. In exemplary embodiments, transducer system

**200** is configured to provide various therapeutic levels of ultrasound to increase a temperature of fat cells in order to maximize the speed at which fat metabolizes. Moreover, transducer system **200** can be configured to deliver various therapeutic levels of ultrasound to increase the speed at which fat metabolizes. According to a modified equation of Arrhenius' Law, a metabolic reaction is a function of temperature and time,  $T: K=Ate.\sup.-B/T$ , where  $K$  is the kinetic rate of fat metabolization,  $A$  is a constant,  $B$  is the activation energy,  $t$  is time, and  $T$  is the temperature in degrees Kelvin. In exemplary embodiments, transducer system **200** is configured to provide various therapeutic levels of ultrasound for a specified time period or for a pulsed delivery over time to increase a temperature of fat cells in order to maximize the speed at which fat metabolizes. Moreover, transducer system **200** can be configured to deliver various therapeutic levels of ultrasound for a specified time period or for a pulsed delivery over time to increase the speed at which fat metabolizes. Thus, ultrasound treatment from transducer system **200**, ranging from approximately 750 kHz to 20 MHz, can increase the temperature in a treatment area, thereby increasing the metabolic reaction yield for that treatment area. As such, fat metabolism in the treatment area is increased which leads to fat cell reduction and decreases the appearance of cellulite above the treatment area. Ultrasound treatment from transducer **200** can be programmed to provide appropriate temperatures and optionally for appropriate time to ROI **210** to increase the spread of fat cell metabolism leading to fat cell destruction and optionally reducing the appearance of cellulite.

**[0057]** In some aspects of the present invention, a method of increasing metabolism of fat cells in a subcutaneous fat layer is provided. The method can include targeting a plurality of fat cells in a subcutaneous fat layer, heating the plurality of fat cells to a temperature as defined by Arrhenius' Law, increasing a metabolism of at least a portion of the plurality of fat cells, and reducing a portion of the plurality of fat cells. The method can also include any physical treatment described herein before, after, and/or concurrent with increasing the metabolism of the fat cells. In addition, the method can include the use a secondary energy as described herein.

**[0058]** As previously described, control systems **104** and **204** may be configured in a variety of manners with various subsystems and subcomponents. With reference to FIGS. **3A** and **3B**, in accordance with exemplary embodiments, an exemplary control system **300** can be configured for coordination and control of the entire therapeutic treatment process in accordance with the adjustable settings made by a therapeutic treatment system user. For example, control system **300** can suitably comprise power source components **302**, sensing and monitoring components **304**, cooling and coupling controls **306**, and/or processing and control logic components **308**. Control system **300** can be configured and optimized in a variety of ways with more or less subsystems and components to implement the therapeutic system for cellulite treatment, and the embodiment in FIGS. **3A** and **3B** are merely for illustration purposes.

**[0059]** For example, for power sourcing components **302**, control system **300** can comprise one or more direct current (DC) power supplies **303** configured to provide electrical energy for entire control system **300**, including power required by transducer electronic amplifier/driver **312**. DC

current sense device **305** can also be provided to confirm the level of power going into amplifiers/drivers **312** for safety and monitoring purposes.

**[0060]** Amplifiers/drivers **312** can comprise multi-channel or single channel power amplifiers and/or drivers. In accordance with an exemplary embodiment for transducer array configurations, amplifiers/drivers **312** can also be configured with a beamformer to facilitate array focusing. An exemplary beamformer can be electrically excited by an oscillator/digitally controlled waveform synthesizer **310** with related switching logic.

**[0061]** Power sourcing components **302** can also include various filtering configurations **314**. For example, switchable harmonic filters and/or matching may be used at the output of amplifier/driver **312** to increase the drive efficiency and effectiveness. Power detection components **316** may also be included to confirm appropriate operation and calibration. For example, electric power and other energy detection components **316** may be used to monitor the amount of power going to an exemplary probe system.

**[0062]** Various sensing and monitoring components **304** may also be suitably implemented within control system **300**. For example, in accordance with an exemplary embodiment, monitoring, sensing and interface control components **324** may be configured to operate with various motion detection systems implemented within transducer probe **104** to receive and process information such as acoustic or other spatial and temporal information from ROI **210**. Sensing and monitoring components can also include various controls, interfacing and switches **309** and/or power detectors **316**. Such sensing and monitoring components **304** can facilitate open-loop and/or closed-loop feedback systems within treatment system **100**.

**[0063]** For example, in such an open-loop system, a system user can suitably monitor the imaging and/or other spatial or temporal parameters and then adjust or modify the same to accomplish a particular treatment objective. Instead of, or in combination with, open-loop feedback configurations, an exemplary treatment system can comprise a closed-loop feedback system, wherein images and/or spatial/temporal parameters can be suitably monitored within monitoring components **304** to generate signals.

**[0064]** During operation of exemplary treatment system **100**, a lesion configuration of a selected size, shape, and orientation is determined. Based on that lesion configuration, one or more spatial parameters are selected, along with suitable temporal parameters, the combination of which yields the desired conformal lesion. Operation of the transducer can then be initiated to provide the conformal lesion or lesions. Open and/or closed-loop feedback systems can also be implemented to monitor the spatial and/or temporal characteristics, and/or other tissue parameter monitoring, to further control the conformal lesions.

**[0065]** Cooling/coupling control systems **306** may be provided to remove waste heat from exemplary probe **104**, provide a controlled temperature at the superficial tissue interface and deeper into tissue, and/or provide acoustic coupling from transducer probe **104** to ROI **210**. Such cooling/coupling control systems **306** can also be configured to operate in both open-loop and/or closed-loop feedback arrangements with various coupling and feedback components.

**[0066]** Processing and control logic components **308** can comprise various system processors and digital control logic

**307**, such as one or more of microcontrollers, microprocessors, field-programmable gate arrays (FPGAs), computer boards, and associated components, including firmware and control software **326**, which interfaces to user controls and interfacing circuits as well as input/output circuits and systems for communications, displays, interfacing, storage, documentation, and other useful functions. System software and firmware **326** controls all initialization, timing, level setting, monitoring, safety monitoring, and all other system functions required to accomplish user-defined treatment objectives. Further, various control switches **308** can also be suitably configured to control operation.

**[0067]** An exemplary transducer probe **104** can also be configured in various manners and can comprise a number of reusable and/or disposable components and parts in various embodiments to facilitate its operation. For example, transducer probe **104** can be configured within any type of transducer probe housing or arrangement for facilitating the coupling of a transducer to a tissue interface, with such housing comprising various shapes, contours and configurations depending on the particular treatment application. For example, in accordance with an exemplary embodiment, transducer probe **104** can be depressed against a tissue interface whereby blood perfusion is partially or wholly cut-off, and tissue is flattened in superficial treatment ROI **210**. Transducer probe **104** can comprise any type of matching, such as for example, electric matching, which may be electrically switchable; multiplexer circuits and/or aperture/element selection circuits; and/or probe identification devices, to certify probe handle, electric matching, transducer usage history and calibration, such as one or more serial EEPROM (memories).

**[0068]** Transducer probe **104** may also comprise cables and connectors; motion mechanisms, motion sensors and encoders; thermal monitoring sensors; and/or user control and status related switches, and indicators such as LEDs. For example, a motion mechanism in probe **104** may be used to controllably create multiple lesions, or sensing of probe motion itself may be used to controllably create multiple lesions and/or stop creation of lesions, e.g. for safety reasons if probe **104** is suddenly jerked or is dropped. In addition, an external motion encoder arm may be used to hold the probe during use, whereby the spatial position and attitude of probe **104** is sent to the control system to help controllably create lesions. Furthermore, other sensing functionality such as profilometers or other imaging modalities may be integrated into the probe in accordance with various exemplary embodiments.

**[0069]** With reference to FIGS. **4A** and **4B**, in accordance with an exemplary embodiment, transducer probe **400** can comprise control interface **402**, transducer **404**, coupling components **406**, and monitoring/sensing components **408**, and/or motion mechanism **410**. However, transducer probe **400** can be configured and optimized in a variety of ways with more or less parts and components to provide ultrasound energy for cellulite treatment and/or fat reduction, and the embodiments illustrated in FIGS. **4A** and **4B** are merely for illustration purposes. In some embodiments, transducer probe **104** is equivalent to transducer probe **400**. In some embodiments, transducer probe **104**, discussed above, can comprise control interface **402**, transducer **404**, coupling components **406**, and monitoring/sensing components **408**, and/or motion mechanism **410**.

**[0070]** In accordance with an exemplary embodiment of the present invention, transducer probe **400** is configured to deliver energy over varying temporal and/or spatial distributions in order to provide energy effects and initiate responses in ROI **210**. These effects can include, for example, thermal, cavitation, hydrodynamic, and resonance induced tissue effects. For example, exemplary transducer probe **400** can be operated under one or more frequency ranges to provide two or more energy effects and initiate one or more responses in ROI **210**. In addition, transducer probe **400** can also be configured to deliver planar, defocused and/or focused energy to ROI **210** to provide two or more energy effects and to initiate one or more reactions. These responses can include, for example, diathermy, hemostasis, revascularization, angiogenesis, growth of interconnective tissue, tissue reformation, ablation of existing tissue, protein synthesis, cell apoptosis, and/or enhanced cell permeability.

**[0071]** These and various other exemplary embodiments of systems and components for such combined ultrasound treatment, effects and responses are more fully set forth in U.S. patent application Ser. No. 10/950,112, entitled "Method and System for Combined Ultrasound Treatment", filed Sep. 24, 2004, published on Apr. 6, 2006 as U.S. Patent Application Publication No. 20060074355, and incorporated herein by reference.

**[0072]** In addition, these and various other exemplary embodiments of systems and components for such combined ultrasound treatment, effects and responses are more fully set forth in U.S. Pat. No. 6,050,943, entitled "Imaging, Therapy, and Temperature Monitoring Ultrasonic System", issued Apr. 18, 2000, and U.S. Pat. No. 6,500,121 entitled "Imaging, Therapy, and temperature Monitoring Ultrasonic System," issued Dec. 31, 2002, both of which are incorporated herein by reference.

**[0073]** Control interface **402** is configured for interfacing with control system **300** to facilitate control of transducer probe **400**. Control interface components **402** can comprise multiplexer/aperture select **424**, switchable electric matching networks **426**, serial EEPROMs and/or other processing components and matching and probe usage information **430** and interface connectors **432**.

**[0074]** Coupling components **406** can comprise various devices to facilitate coupling of transducer probe **400** to ROI **210**. For example, coupling components **406** can comprise cooling and acoustic coupling system **420** configured for acoustic coupling of ultrasound energy and signals. Coupling system **420** with possible connections such as manifolds may be utilized to couple sound into ROI **210**, control temperature at the interface and deeper into tissue, provide liquid-filled lens focusing, and/or to remove transducer waste heat. Coupling system **420** may facilitate such coupling through use of various coupling mediums, including air and other gases, water and other fluids, gels, solids, and/or any combination thereof, or any other medium that allows for signals to be transmitted between transducer active elements **412** and ROI **210**. In addition to providing a coupling function, in accordance with an exemplary embodiment, coupling system **420** can also be configured for providing temperature control during the treatment application. For example, coupling system **420** can be configured for controlled cooling of an interface surface or region between transducer probe **400** and ROI **210** and beyond by suitably controlling the temperature of the coupling

medium. The suitable temperature for such coupling medium can be achieved in various manners, and utilize various feedback systems, such as thermocouples, thermistors or any other device or system configured for temperature measurement of a coupling medium. Such controlled cooling can be configured to further facilitate spatial and/or thermal energy control of transducer probe 400.

[0075] Monitoring and sensing components 408 can comprise various motion and/or position sensors 416, temperature monitoring sensors 418, user control and feedback switches 414 and other like components for facilitating control by control system 300, e.g., to facilitate spatial and/or temporal control through open-loop and closed-loop feedback arrangements that monitor various spatial and temporal characteristics.

[0076] Motion mechanism 410 can comprise manual operation, mechanical arrangements, or some combination thereof. For example, motion mechanism 422 can be suitably controlled by control system 300, such as through the use of accelerometers, encoders or other position/orientation devices 416 to determine and enable movement and positions of transducer probe 400. Linear, rotational or variable movement can be facilitated, e.g., those depending on the treatment application and tissue contour surface.

[0077] Transducer 404 can comprise one or more transducers configured for producing conformal lesions of thermal injury in superficial human tissue within ROI 210 through precise spatial and temporal control of acoustic energy deposition. Transducer 404 can also comprise one or more transduction elements and/or lenses 412. The transduction elements can comprise a piezoelectrically active material, such as lead zirconate titanate (PZT), or any other piezoelectrically active material, such as a piezoelectric ceramic, crystal, plastic, and/or composite materials, as well as lithium niobate, lead titanate, barium titanate, and/or lead metaniobate. In addition to, or instead of, a piezoelectrically active material, transducer 404 can comprise any other materials configured for generating radiation and/or acoustical energy. Transducer 404 can also comprise one or more matching layers configured along with the transduction element such as coupled to the piezoelectrically active material. Acoustic matching layers and/or damping may be employed as necessary to achieve the desired electroacoustic response.

[0078] In accordance with an exemplary embodiment, the thickness of the transduction element of transducer 404 can be configured to be uniform. That is, transduction element 412 can be configured to have a thickness that is substantially the same throughout. In accordance with another exemplary embodiment, the thickness of transduction element 412 can also be configured to be variable. For example, transduction element(s) 412 of transducer 404 can be configured to have a first thickness selected to provide a center operating frequency of a lower range, for example from approximately 750 kHz to 5 MHz. Transduction element 404 can also be configured with a second thickness selected to provide a center operating frequency of a higher range, for example from approximately 5 MHz to 20 MHz or more. Transducer 404 can be configured as a single broadband transducer excited with at least two or more frequencies to provide an adequate output for generating a desired response. Transducer 404 can also be configured as two or more individual transducers, wherein each transducer comprises one or more transduction element. The thickness of

the transduction elements can be configured to provide center-operating frequencies in a desired treatment range. For example, transducer 404 can comprise a first transducer configured with a first transduction element having a thickness corresponding to a center frequency range of approximately 750 kHz to 5 MHz, and a second transducer configured with a second transduction element having a thickness corresponding to a center frequency of approximately 5 MHz to 20 MHz or more.

[0079] Transducer 404 may be composed of one or more individual transducers in any combination of focused, planar, or unfocused single-element, multi-element, or array transducers, including 1-D, 2-D, and annular arrays; linear, curvilinear, sector, or spherical arrays; spherically, cylindrically, and/or electronically focused, defocused, and/or lensed sources.

[0080] In accordance with another exemplary embodiment, transducer probe 400 may be suitably configured to provide three-dimensional treatment. For example, to provide three-dimensional treatment of ROI 210, with reference again to FIG. 4, a three-dimensional system can comprise transducer probe 400 configured with an adaptive algorithm, such as, for example, one utilizing three-dimensional graphic software, contained in a control system, such as for example control system 300. The adaptive algorithm is suitably configured to receive two-dimensional imaging, temperature monitoring and/or treatment information relating to ROI 210, process the received information, and then provide corresponding three-dimensional imaging, temperature and/or treatment information.

[0081] In accordance with another aspect of the invention, transducer probe 400 may be configured to provide one, two or three-dimensional treatment applications for focusing acoustic energy to one or more regions of interest. For example, as discussed above, transducer probe 400 can be suitably diced to form a one-dimensional array, e.g., a transducer comprising a single array of sub-transduction elements.

[0082] For example, with reference to an exemplary embodiment depicted in FIG. 5, exemplary transducer 500 can be configured as an acoustic array 502 to facilitate phase focusing. That is, transducer 500 can be configured as an array of electronic apertures that may be operated by a variety of phases via variable electronic time delays. By the term "operated," the electronic apertures of transducer 500 may be manipulated, driven, used, and/or configured to produce and/or deliver an energy beam corresponding to the phase variation caused by the electronic time delay. For example, these phase variations can be used to deliver defocused beams 508, planar beams 504, and/or focused beams 506, each of which may be used in combination to achieve different physiological effects in ROI 210. Transducer 500 may additionally comprise any software and/or other hardware for generating, producing and or driving a phased aperture array with one or more electronic time delays.

[0083] Transducer 500 can also be configured to provide focused treatment to one or more regions of interest using various frequencies. In order to provide focused treatment, transducer 500 can be configured with one or more variable depth devices to facilitate treatment. For example, transducer 500 may be configured with variable depth devices disclosed in commonly assigned U.S. patent application Ser. No. 10/944,500, entitled "System and Method for Variable

Depth Ultrasound”, filed on Sep. 16, 2004, published on Mar. 16, 2006, as U.S. Patent Application Publication No. 20060058664, and incorporated herein by reference. In some embodiments, transducer probe **104** or transducer probe **400** can comprise transducer **500**.

**[0084]** In addition, transducer **500** can also be configured to treat one or more additional ROI **210** through the enabling of sub-harmonics or pulse-echo imaging, as disclosed in commonly assigned U.S. patent application Ser. No. 10/944, 499, entitled “Method and System for Ultrasound Treatment with a Multi-directional Transducer”, filed on Sep. 16, 2004, published on Mar. 16, 2006 as U.S. Patent Application Publication No. 20060058707, and incorporated herein by reference.

**[0085]** Moreover, any variety of mechanical lenses or variable focus lenses, e.g. liquid-filled lenses, may also be used to focus and/or defocus the sound field. For example, with reference to exemplary embodiments depicted in FIGS. **6A** and **6B**, transducer **600** may also be configured with an electronic focusing array **604** in combination with one or more transduction elements **606** to facilitate increased flexibility in treating ROI **210**. Array **604** may be configured in a manner similar to transducer **502**. That is, array **604** can be configured as an array of electronic apertures that may be operated by a variety of phases via variable electronic time delays, for example,  $T_1, T_2 \dots T_j$ . By the term “operated,” the electronic apertures of array **604** may be manipulated, driven, used, and/or configured to produce and/or deliver energy in a manner corresponding to the phase variation caused by the electronic time delay. For example, these phase variations can be used to deliver defocused beams, planar beams, and/or focused beams, each of which may be used in combination to achieve different physiological effects in ROI **210**.

**[0086]** Transduction elements **606** may be configured to be concave, convex, and/or planar. For example, in an exemplary embodiment depicted in FIG. **6A**, transduction elements **606** are configured to be concave in order to provide focused energy for treatment of ROI **210**. Additional embodiments of transducer **600** are disclosed in U.S. patent applications and U.S. patents that have been incorporated by reference herein.

**[0087]** In another exemplary embodiment, depicted in FIG. **6B**, transduction elements **606** can be configured to be substantially flat in order to provide substantially uniform energy to ROI **210**. While FIGS. **6A** and **6B** depict exemplary embodiments with transduction elements **604** configured as concave and substantially flat, respectively, transduction elements **604** can be configured to be concave, convex, and/or substantially flat. In addition, transduction elements **604** can be configured to be any combination of concave, convex, and/or substantially flat structures. For example, a first transduction element can be configured to be concave, while a second transduction element can be configured to be substantially flat. In some embodiments, transducer probe **104** or transducer probe **400** can comprise transducer **600**.

**[0088]** To further illustrate the various structures for transducer **404**, with reference to FIG. **7**, ultrasound therapy transducer **700** can be configured for a single focus, an array of foci, a locus of foci, a line focus, and/or diffraction patterns. Transducer **700** can also comprise single elements, multiple elements, annular arrays, one-, two-, or three-dimensional arrays, broadband transducers, and/or combi-

nations thereof, with or without lenses, acoustic components, and mechanical and/or electronic focusing. Transducers configured as spherically focused single elements **702**, annular arrays **704**, annular arrays with damped regions **706**, line focused single elements **708**, 1-D linear arrays **710**, 1-D curvilinear arrays in concave or convex form, with or without elevation focusing, 2-D arrays, and 3-D spatial arrangements of transducers may be used to perform therapy and/or imaging and acoustic monitoring functions. For any transducer configuration, for example but not limited to including those employed in transducer probe **104** or transducer probe **400**, focusing and/or defocusing may be in one plane or two planes via mechanical focus **720**, convex lens **722**, concave lens **724**, compound or multiple lenses **726**, planar form **728**, or stepped form, such as illustrated in FIG. **10F**. Any transducer or combination of transducers may be utilized for treatment. For example, an annular transducer may be used with an outer portion dedicated to therapy and the inner disk dedicated to broadband imaging wherein such imaging transducer and therapy transducer have different acoustic lenses and design, such as illustrated in FIGS. **10C-10F**, as described below.

**[0089]** With reference to FIGS. **8A** and **8B**, transducer **404** can be configured as single-element arrays, wherein a single-element **802**, e.g., a transduction element of various structures and materials, can be configured with a plurality of masks **804**, such masks comprising ceramic, metal or any other material or structure for masking or altering energy distribution from element **802**, creating an array of energy distributions **808**. Masks **804** can be coupled directly to element **802** or separated by a standoff **806**, such as any suitably solid or liquid material.

**[0090]** In accordance with another exemplary embodiment, transducer probe **104** or transducer probe **400** may be suitably diced in two dimensions to form a two-dimensional array. For example, with reference to FIG. **9**, an exemplary two-dimensional array **900** can be suitably diced into a plurality of two-dimensional portions **902**. Two-dimensional portions **902** can be suitably configured to focus on the treatment region at a certain depth, and thus provide respective slices **904**, **907** of the treatment region. As a result, the two-dimensional array **900** can provide a two-dimensional slicing of image planes of a treatment region, thus providing two-dimensional treatment.

**[0091]** In accordance with another exemplary embodiment, transducer probe **400** may be suitably configured to provide three-dimensional treatment. For example, to provide three-dimensional treatment of ROI **210**, with reference again to FIG. **3**, a three-dimensional system can comprise transducer probe **104** or transducer probe **400** configured with an adaptive algorithm, such as, for example, one utilizing three-dimensional graphic software, contained in a control system, such as for example control system **300**. The adaptive algorithm is suitably configured to receive two-dimensional imaging, temperature and/or treatment information relating to ROI **210**, process the received information, and then provide corresponding three-dimensional imaging, temperature and/or treatment information.

**[0092]** In accordance with an exemplary embodiment, with reference again to FIG. **9**, an exemplary three-dimensional system can comprise a two-dimensional array **900** configured with an adaptive algorithm to suitably receive **904** slices from different image planes of the treatment region, process the received information, and then provide

volumetric information **906**, e.g., three-dimensional imaging, temperature and/or treatment information. Moreover, after processing the received information with the adaptive algorithm, the two-dimensional array **900** may suitably provide therapeutic heating to the volumetric region **906** as desired.

[**0093**] Alternatively, rather than utilizing an adaptive algorithm, such as three-dimensional software, to provide three-dimensional imaging and/or temperature information, an exemplary three-dimensional system can comprise a single transducer **404** configured within a probe arrangement to operate from various rotational and/or translational positions relative to a target region.

[**0094**] An exemplary transducer **404** can also be configured as an annular array to provide planar, focused and/or defocused acoustical energy. For example, with reference to FIGS. **10A** and **10B**, in accordance with an exemplary embodiment, an annular array **1000** can comprise a plurality of rings **1012**, **1014**, **1016** to **N**. Rings **1012**, **1014**, **1016** to **N** can be mechanically and electrically isolated into a set of individual elements, and can create planar, focused, or defocused waves. For example, such waves can be centered on-axis, such as by methods of adjusting corresponding transmit and/or receive delays,  $T_1, T_2, T_3, \dots, T_N$ . An electronic focus can be suitably moved along various depth positions, and can enable variable strength or beam tightness, while an electronic defocus can have varying amounts of defocusing. In accordance with an exemplary embodiment, a lens and/or convex or concave shaped annular array **1000** can also be provided to aid focusing or defocusing such that at any time differential delays can be reduced. Movement of annular array **1000** in one, two or three-dimensions, or along any path, such as through use of probes and/or any conventional robotic arm mechanisms, may be implemented to scan and/or treat a volume or any corresponding space within ROI **210**.

[**0095**] Transducer **404** can also be configured in other annular or non-array configurations for imaging/therapy functions. For example, with reference to FIGS. **10C-10F**, a transducer can comprise an imaging element **1012** configured with therapy element(s) **1014**. Elements **1012** and **1014** can comprise a single-transduction element, e.g., a combined imaging/transducer element, or separate elements, can be electrically isolated **1022** within the same transduction element or between separate imaging and therapy elements, and/or can comprise standoff **1024** or other matching layers, or any combination thereof. For example, with particular reference to FIG. **10F**, a transducer can comprise an imaging element **1012** having a surface **1028** configured for focusing, defocusing or planar energy distribution, with therapy elements **1014** including a stepped-configuration lens configured for focusing, defocusing, or planar energy distribution.

[**0096**] Various shaped treatment lesions can be produced using the various acoustic lenses and designs in FIGS. **10A-10F**. For example, mushroom-shaped lesions may be produced from a spherically-focused source, and/or planar lesions from a flat source. That is, as the application of ablative ultrasound energy continues, this causes thermal expansion to generate a growing lesion. Concave planar sources and arrays can produce a “V-shaped” or ellipsoidal lesion. Electronic arrays, such as a linear array, can produce defocused, planar, or focused acoustic beams that may be employed to form a wide variety of additional lesion shapes at various depths. An array may be employed alone or in

conjunction with one or more planar or focused transducers. Such transducers and arrays in combination produce a very wide range of acoustic fields and their associated benefits. A fixed focus and/or variable focus lens or lenses may be used to further increase treatment flexibility. A convex-shaped lens, with acoustic velocity less than that of superficial tissue, may be utilized, such as a liquid-filled lens, gel-filled or solid gel lens, rubber or composite lens, with adequate power handling capacity; or a concave-shaped, low profile, lens may be utilized and composed of any material or composite with velocity greater than that of tissue. While the structure of transducer source and configuration can facilitate a particular shaped lesion as suggested above, such structures are not limited to those particular shapes as the other spatial parameters, as well as the temporal parameters, can facilitate additional shapes within any transducer structure and source.

[**0097**] In accordance with an exemplary embodiment, with additional reference to FIG. **11**, acoustic coupling and cooling **1140** can be provided to acoustically couple energy and imaging signals from transducer probe **1104** to and from ROI **210**, to provide thermal control at the probe to ROI **210** interface **1110**, and to remove potential waste heat from the transducer probe at region **1144**. Temperature monitoring can be provided at the coupling interface via thermal sensor **1146** to provide a mechanism of temperature measurement **1148** and control via control system **1106** and thermal control system **1142**. Thermal control may consist of passive cooling such as via heat sinks or natural conduction and convection or via active cooling such as with pettier thermoelectric coolers, refrigerants, or fluid-based systems comprised of pump, fluid reservoir, bubble detection, flow sensor, flow channels/tubing **1144** and thermal control **1142**. In some embodiments, transducer probe **1104** can be equivalent to transducer probe **104** or transducer probe **400**.

[**0098**] In accordance with another exemplary embodiment, with reference to FIG. **12**, an exemplary treatment system **200** can be configured with and/or combined with various auxiliary systems to provide additional functions. For example, an exemplary treatment system **1200** for treating ROI **210** can comprise a control system **1206**, a probe **1204**, and a display **1208**. In some embodiments, probe **1204** can be equivalent to transducer probe **104** or transducer probe **400** or transducer probe **1104**. Treatment system **1200** further comprises an auxiliary imaging modality **1274** and/or auxiliary monitoring modality **1272** may be based upon at least one of photography and other visual optical methods, magnetic resonance imaging (MRI), computed tomography (CT), optical coherence tomography (OCT), electromagnetic, microwave, or radio frequency (RF) methods, positron emission tomography (PET), infrared, ultrasound, acoustic, or any other suitable method of visualization, localization, or monitoring of cellulite within ROI **210**, including imaging/monitoring enhancements. Such imaging/monitoring enhancement for ultrasound imaging via probe **1204** and control system **1206** could comprise M-mode, persistence, filtering, color, Doppler, and harmonic imaging among others; furthermore an ultrasound treatment system **1270**, as a primary source of treatment, may be combined with a secondary source of treatment **1276**, including radio frequency (RF), intense pulsed light (IPL), laser, infrared laser, microwave, or any other suitable energy source.

[0099] An ultrasound treatment system as described herein, as a primary source of treatment, may be combined with a secondary source of treatment configured to deliver secondary treatment energy. Secondary treatment energy includes, but is not limited to, radio frequency (RF) energy, microwave energy, infrared light, visible light, ultraviolet light, and any other suitable electromagnetic energy. Secondary treatment energy may be coherent (as in a laser), incoherent, scattered, pulsed, refracted, focused, defocused, and/or delivered in any other form suitable for achieving a bio-effect.

[0100] In an exemplary embodiment, ultrasound treatment is combined with blue light treatment. As used herein, "blue light" means electromagnetic energy having a wavelength from about 400 nanometers to about 440 nanometers. Blue light is applied to the skin. Blue light may be applied as a pretreatment before therapeutic ultrasound energy is applied. Blue light may also be applied concurrently with therapeutic ultrasound energy. Furthermore, blue light may be applied before, during, or after therapeutic ultrasound treatment, or during any combination thereof.

[0101] In accordance with an exemplary embodiment, blue light is applied to ROI 210 for a period between 5 seconds and 20 minutes. Blue light may be applied to ROI 210 for any suitable amount of time in order to achieve a desired bio-effect.

[0102] In another exemplary embodiment, ultrasound treatment is combined with red light treatment. As used herein, "red light" means electromagnetic energy having a wavelength from about 600 nanometers to about 1350 nanometers. Red light is applied to ROI 210. Red light may be applied as a pretreatment before therapeutic ultrasound energy is applied. Red light may also be applied concurrently with therapeutic ultrasound energy. Furthermore, red light may be applied before, during, or after therapeutic ultrasound treatment, or during any combination thereof.

[0103] In accordance with an exemplary embodiment, red light is applied to the skin for a period between 5 seconds and 20 minutes. Red light may be applied to the skin for any suitable amount of time in order to achieve a desired bio-effect.

[0104] In accordance with an exemplary embodiment, secondary treatment energy can be delivered by the probe which contains an ultrasound energy source. In other exemplary embodiments, secondary treatment energy is delivered by a source external to the probe. Secondary treatment energy may be generated by a light emitting diode (LED), a laser, an incandescent bulb, a fluorescent tube, an antenna, an intense pulsed light source, or any other suitable electromagnetic energy generation mechanism.

[0105] In one exemplary embodiment, energy is delivered in relatively small ablative areas in order to minimize and/or prevent scar tissue from forming. That is, each ablative area of treatment can range from approximately 100 microns to 55 mm in diameter. In another exemplary embodiment, ultrasound energy is used in a "lawnmower" type fashion to evenly ablate a treatment region to provide a substantially planar surface of lobuli. This "lawnmower"-type ablation in turn, helps to achieve a substantially smooth surface of the epidermis.

[0106] With reference to FIG. 13, another method of non-invasive treatment of cellulite is illustrated according to various other embodiments of the present invention. The cross-sectional diagram illustrates the layers of tissue below

skin surface 1304 which is not to scale and is used for illustration purposes. Dermis layer 1302 includes skin surface 1304 and both the epidermis and dermis portions of the skin. Below the dermis layer 1302 is fat lobuli 1307. Fat lobuli 1307 causes protrusions in skin surface 1304, which gives skin surface 1304 a dimpled appearance 1311 or cellulite. Below fat lobuli 1307 is fascia layer 1315, subcutaneous fat layer 1317 and then muscle layer 1319.

[0107] In various aspects, probe 202 is coupled to skin surface 1304 and emits ultrasound energy to create conformal lesion 209 at specific depth 1305. Conformal lesion 209 ablates a portion of fat lobuli 1307. Probe movement 1303 along skin surface 1304 allows for ablation of a plurality of fat lobuli 1307 at specific depth 1305. This may be described as a lawnmower type ablation or a haircut of fat lobuli 1307. Probe movement 1303 leaves behind smoothed skin 1309. The treatment may need to be repeated in order to achieve a desired degree of smoothed skin 1309. This method may be combined with any other method steps described herein such as for example applying a physical treatment or applying a secondary energy source.

[0108] In accordance with an exemplary embodiment of the present invention, a method of non-invasive treatment of cellulite includes targeting ROI 210 below skin surface 1304, which contains fat lobuli 1307, and delivering ultrasound energy at specified depth 1305 below skin surface 1304. The method further includes moving a source of the energy along skin surface 1304 and ablating a portion of fat lobuli 1307 at specified depth 1305 below skin surface 1304.

[0109] Specified depth 1305 is generally in the range of about 1 mm to about 35 mm below skin surface 1304. The method can include applying a physical treatment as described herein. The method can smooth skin surface 1304 and may reduce the appearance of cellulite on skin surface 1304. The method can further include any of the additional method steps discussed herein.

[0110] With reference to FIG. 14, a method of non-invasive treatment of cellulite is illustrated according to another exemplary embodiment of the present invention. The cross-sectional diagram illustrates the layers of tissue below skin surface 1304 which is not to scale and is used for illustration purposes. Dermis layer 1302 includes skin surface 1304 and both the epidermis and dermis portions of the skin. Below dermis layer 1302 is fat lobuli 1307. Fat lobuli 1307 causes protrusions in skin surface 1304, which gives skin surface 1304 a dimpled appearance 1311 or cellulite. Below fat lobuli 1307 is fascia layer 1315, subcutaneous fat layer 1317 and then muscle layer 1319.

[0111] In the exemplary embodiment illustrated in FIG. 14A, probe 202 is coupled to skin surface 1304 and emits ultrasound energy to create conformal lesion 209 in the surface of fat lobuli 1307 to create opening 1321. A material that is housed in the punctured fat lobuli 1317 flows out of opening 1321. This material can be a fluid, a lipid, a lymphatic substance, fat, tissue, bodily materials, or any other material and mixtures thereof. The material can be any tissue, fluid, or the like that is typically housed in fat lobuli 1317. Moving to FIG. 14B, reduced fat lobuli 1325 has shriveled due to the loss of the material. The shrinking of reduced fat lobuli 1325 can cause smoothed skin 1309 above reduced fat lobuli 1325 which has been drained of the material, thereby reducing the appearance of cellulite on skin surface 1304.

[0112] In accordance with another exemplary embodiment, a method of non-invasive treatment of cellulite includes targeting ROI 210 below skin surface 1304, which contains fat lobuli 1307 and delivering ultrasound energy to ROI 210. The ultrasound energy generates conformal lesion 209 with the ultrasound energy on a surface of fat lobuli 1307. The lesion creates opening 1321 in the surface of fat lobuli 1307, which allows the draining of a fluid out of fat lobuli 1307 and through opening 1321.

[0113] The method can further include heating ROI 210 to a temperature in a range from about 43° C. to about 49° C., which can stimulate apoptosis of at least one fat cell in fat lobuli 1307. Still further the method can include applying a physical treatment to skin surface 1304 and such physical treatment can include mesotherapy, iontophoresis, pressotherapy, pneumatic massage, lymphatic drainage, electrolipophoresis, roller massage, low frequency ultrasound, vacuum suction, laser energy, and/or an application of RF energy. The physical treatment can be before, after, or concurrent with the delivery of the ultrasound energy. The method can include the use of a second energy, which can be used before, after, or concurrent with the delivery of the ultrasound energy. The method can reduce the appearance of cellulite on skin surface 1304.

[0114] With additional reference to FIG. 15, a block diagram illustrates an exemplary method for non-invasive treatment of cellulite according to various embodiments of the present invention. For example, method 1500 is a non-invasive treatment of cellulite. In step 1502, fat lobuli 1307 is targeted. Imaging the fat lobuli in a step 1503 may be useful in the targeting of fat lobuli 1307 but is optional or otherwise not required.

[0115] Targeting step 1502 is followed by energy delivery step 1504 which delivers ultrasound energy to form a conformal lesion 209 in the target which can be for example fat lobuli 1307. The ultrasound energy can be in the range from about 750 kHz to about 20 MHz and may be more useful in the range from about 2 MHz to about 10 MHz. The power of the ultrasound energy may be in a range from about 1 W to about 50 W and may be more useful in the range from about 2 W to about 20 W. The duration of the ultrasound energy may be in the range from about 10 milliseconds to about 20 minutes, or even more if desired. Energy delivery step 1504 may include applying secondary energy step 1505, which is optional. Applying a secondary energy step 1505 may be useful in heating the tissue around the target to an elevated temperature prior to or during delivery of ultrasound energy to the targeted region, and can comprise a variety of energy sources including those discussed previously herein.

[0116] Energy delivery step 1504 is followed by creating an opening in the target step 1506, which provides an opening 1321. In this step 1506, conformal lesion 209 creates opening 1321 in the target. Upon creating an opening in the target, step 1506 is followed by a release of contents step 1508, in which at least a portion of the contents of fat lobuli 1307 are released through opening 1321, e.g., by draining. An application of secondary energy step 1505 may be applied after the creation of opening 1321 but is optional. Such application of secondary energy step 1505 may be useful in smoothing skin surface 1304 and/or in facilitating movement of at least a portion of the contents of fat lobuli 1307 to facilitate their release. The contents of fat lobuli 1307 can be a fluid, a lipid, a lymphatic substance, fat,

tissue, bodily materials, or any other material and mixtures thereof. An application of physical treatment step 1507, such as, for example, by applying physical pressure or force to facilitate movement, may be useful in facilitating the releasing of at least a portion of the contents of fat lobuli 1307 through opening 1321, but this step 1507 is optional. An optional imaging step 1509 can be added for reviewing if the treatment was successful. If the treatment complete decision 1511 is yes, then the result is the final step 1510 wherein the skin is smoothed. If the treatment complete decision 1511 is no, then move to step 1504 for further treatment of the target until the treatment is successful within the treatment area, resulting in the smoothing of skin step 1510 which reduces the appearance of cellulite on skin surface 1304.

[0117] In accordance with another exemplary embodiment, a method of non-invasive treatment of cellulite includes identifying fat lobuli 1307 and creating a sharp focal of ultrasound energy onto fat lobuli 1307. The focal of energy pierces fat lobuli 1307 to create opening 1321, which then allows the flowing of a material out of fat lobuli 1307 through opening 1321. The method can further include any of the additional method steps discussed herein.

[0118] Now referring to FIG. 16, a method of non-invasive treatment for a reduction of fat is illustrated according to another exemplary embodiment of the present invention. In various embodiments, this method can be used as a non-invasive treatment of cellulite. The cross-sectional diagram illustrates the layers of tissue below skin surface 1304 which is not to scale and is used for illustration purposes. Dermis layer 1302 includes skin surface 1304 and both the epidermis and dermis portions of the skin. Below dermis layer 1302 is fat lobuli 1307. Fat lobuli 1307 causes protrusions in skin surface 1304, which gives skin surface 1304 a dimpled appearance 1311 or cellulite. Below fat lobuli 1307 is fascia layer 1315, subcutaneous fat layer 1317 and then muscle layer 1319.

[0119] In an exemplary embodiment, as illustrated in FIG. 16A, probe 202 is coupled to skin surface 1304 and emits ultrasound energy into adipose target area 1331. Adipose target area 1331 can include a portion of fat lobuli 1307. Adipose target area 1331 can include ROI 210. Fat lobuli 1307 can contain a plurality of adipose cells and a portion of the plurality of adipose cells can be located in adipose target area 1331. Adipose target area 1331 can include a plurality of other adipose cells 1329 that may be amongst fat lobuli 1307.

[0120] Probe 202 is targeted to deliver energy in adipose target area 1331. Adipose target area 1331 can be from about 1 mm to about 100 mm or greater below skin surface 1304. Height 1333 of adipose target area 1331 can be from about 1 mm to about 10 mm or greater. Probe 202 delivers energy to create at least one conformal lesion 209 in adipose target area 1331. Delivered energy raises a temperature of at least a portion of adipose cells in fat lobuli 1307 and/or other adipose cells 1329 located in adipose target area 1331 to a range from about 43° C. to about 49° C., which stimulates apoptosis of fat cells, which can include at least a portion of other adipose cells in fat lobuli 1307 and/or other adipose cells 1329.

[0121] As illustrated in FIG. 16B, over a period of time, the portion of the plurality of adipose cells fat lobuli 1307 that were located in adipose target zone 1331 begin cell apoptosis. As these adipose cells die, fat lobuli 1307 shrinks. This cell apoptosis of the adipose cells reduces the amount

of fat in an area on a patient. The effect of the reduction in size of fat lobuli 1307 by the adipose cell apoptosis can create smoothed skin 1309. In addition, other adipose cells 1329 that were located in adipose target area 1331 can begin cell apoptosis. As these other adipose cells 1329 die, skin surface 1304 can relax, which can contribute to creating smoothed skin 1309. Probe 202 can be moved along skin surface 1304 to enlarge the treatment of adipose target area 1331 of a patient's body.

[0122] An exemplary method, such as that illustrated by FIG. 16, can include applying a physical treatment to skin surface 1304, and such physical treatment can include mesotherapy, Iontophoresis, pressotherapy, pneumatic massage, lymphatic drainage, electrolipophoresis, roller massage, low frequency ultrasound, vacuum suction, laser energy, and application of RF energy. The physical treatment can be before, after, or concurrent with the delivery of the energy. The method can include the use of a second energy, which can be used before, after, or concurrent with the delivery of the energy.

[0123] With reference to FIG. 17, a block diagram illustrates a method 1600 of fat reduction according to an exemplary embodiment. For example, the method 1600 begins with step 1602 which is the targeting of a group of fat cells in adipose target area 1331. This targeting step 1602 may include the movement of probe 202 to include an enlarged target area. In targeting step 1602 a depth below skin surface 1304 that is appropriate for adipose target area 1331 is determined. Generally, a depth of greater than 1 mm but less than 100 mm is appropriate and this can vary from patient to patient depending on location on the body and level of patient's body fat.

[0124] Targeting step 1602 is followed by energy delivery step 1603 which is the delivering of ultrasound energy to the target fat cells. The ultrasound energy can be in the range from about 750 kHz to about 20 MHz and may be more useful in the range from about 2 MHz to about 10 MHz. The power of the ultrasound energy may be in a range from about 1 W to about 50 W and may be more useful in the range from about 2 W to about 20 W. The duration of the ultrasound energy may be in the range from about 10 milliseconds to about 20 minutes, or more if desired.

[0125] Energy delivery step 1603 is followed by raising temperature step 1604, which is the raising of the fat cell temperature from about 43.5° C. to about 49° C. Different combinations of parameters outlined in energy delivery step 1603 can be useful to raise the fat cell temperature to the desired range in step 1604. Raising temperature step 1604 creates or facilitates the stimulating apoptosis step 1605 which is the stimulating cell apoptosis of the fat cells in adipose target area 1331. If the fat cells are held in the desired temperature range for a sufficient amount of time, cell apoptosis will occur. Stimulating apoptosis step 1605 is followed by step 1606 which is the allowing of the targeted fat cells and/or targeted portions thereof to die. Upon allowing target portions to die in step 1606 results, a reduction of the total number of fat cells in adipose target area 1331 is achieved 1607. This reduction of the total number of fat cells can result in lowering the circumference of a patient's body, for example the circumference of thighs, buttocks, hips, waist, and the like. In addition, this reduction of adipose target area 1331 can reduce an appearance of cellulite on skin surface 1304. Alternatively, or simultane-

ously, method 1600 can target fat cells in the subcutaneous fat layers to provide similar results.

[0126] Now with reference to FIGS. 18A and 18B, a method of non-invasive treatment for a reduction of fat is illustrated according to various exemplary embodiments of the present invention. In various embodiments, this method can be used as a non-invasive treatment of subcutaneous fat layer 1317. The cross-sectional diagram illustrates the layers of tissue below skin surface 1304 which is not to scale and is used for illustration purposes. The dermis layer 1302 includes skin surface 1304 and both the epidermis and dermis portions of the skin. Below dermis layer 1302 is fat lobuli 1307. Fat lobuli 1307 causes protrusions in skin surface 1304, which gives skin surface 1304 a dimpled appearance 1311 or cellulite. Below fat lobuli 1307 is fascia layer 1315, subcutaneous fat layer 1317 and then muscle layer 1319. Subcutaneous fat layer 1317 can have a selected depth 1337.

[0127] In an exemplary embodiment as illustrated in FIG. 18A, probe 202 is coupled to skin surface 1304 and emits ultrasound energy into adipose target area 1331. Adipose target area 1331 can include a portion of subcutaneous fat layer 1317. Subcutaneous fat layer 1317 can contain a plurality of adipose cells and a portion of the plurality of adipose cells can be located in adipose target area 1331.

[0128] Probe 202 is targeted to deliver energy in adipose target area 1331. Adipose target area 1331 can be from about 1 mm to about 100 mm or greater below the surface of the skin 1304. Height 1333 of adipose target area 1331 can be from about 1 mm to about 10 mm or greater. Probe 202 delivers energy to create at least one conformal lesion 209 which is located in adipose target area 1331. Delivered energy raises a temperature of at least a portion of the adipose cells located in adipose target area 1331 in to a range from about 43° C. to about 49° C., which stimulates apoptosis of the fat cells, which can include at least a portion of adipose cells in fat lobuli 1307 and/or other adipose cells 1399.

[0129] Over a period of time, the portion of the plurality of adipose cells in subcutaneous fat layer 1317 that were located in adipose target area 1331 begin cell apoptosis. As these adipose cells die, subcutaneous fat layer 1317 shrinks. This cell apoptosis of the adipose cells reduces the amount of fat in an area on a patient. As illustrated in FIG. 18B, the effect of the adipose cell apoptosis in subcutaneous fat layer 1317 can create smoothed skin 1309.

[0130] In addition, the effect of the adipose cell apoptosis in subcutaneous fat layer 1317 can create a reduction 1335 in the total volume of tissue in the treatment area. In accordance with the method, probe 202 can be moved along skin surface 1304 to enlarge the treatment of adipose target area 1331 of a patient's body. For example, this reduction 1335 can cause a decrease in the circumference of a patient's thighs, buttocks, hips, waist, and the like. As the adipose cell apoptosis in subcutaneous fat layer 1317 continues, skin surface 1304 can relax and can contribute to creating smoothed skin 1309. Subcutaneous fat layer 1317 can have a reduced depth 1339 after cell apoptosis. Reduced cell depth 1339 generally results from thickness of depth 1337 less the thickness 1333 of adipose target area 1331, i.e., the portion shrunk from cell apoptosis.

[0131] Various exemplary methods as illustrated in FIG. 18 provide a method of non-invasively stimulating apoptosis of a fat cell located in subcutaneous fat layer 1317. The

method includes targeting at least one fat cell in subcutaneous fat layer 1317 below skin surface 1304 and delivering energy to the fat cell. The delivered energy raises a temperature of the fat cell into a range from about 43° C. to about 49° C., which stimulates apoptosis of the fat cell.

[0132] The method can further include imaging of a fat cell or fat lobuli 1307. Still further, the method can include generating conformal lesion 209 into at least one fat cell, which can create opening 1321 in a fat cell or fat lobuli 1307 and allow the moving of a material out of a fat cell or fat lobuli 1307 and through opening 1321. This material can be a fluid, a lipid, a lymphatic substance, fat, tissue, bodily materials, or any other material and mixtures thereof. The ultrasound energy can be in the range from about 750 kHz to about 20 MHz and may be more useful in the range from about 2 MHz to about 10 MHz. The power of the ultrasound energy may be in a range from about 1 W to about 50 W and may be more useful in the range from about 2 W to about 20 W. The duration of the ultrasound energy may be in the range from about 10 milliseconds to about 20 minutes. Still further, the method can include applying a physical treatment to skin surface 1304 and such physical treatment can include mesotherapy, iontophoresis, pressotherapy, pneumatic massage, lymphatic drainage, electrolipophoresis, roller massage, low frequency ultrasound, vacuum suction, laser energy, and application of RF energy. The physical treatment can be before, after, or concurrent with the delivery of the energy. The method can include the use of a second energy, which can be used before, after, or concurrent with the delivery of the energy. The method can reduce the number of fat cells in subcutaneous fat layer 1317.

[0133] In addition, various other exemplary embodiments of the present invention can include a method that combines fat reduction and cellulite reduction. The method includes targeting ROI 210 below skin surface 1304, which contains fat lobuli 1307 and delivering ultrasound energy to ROI 210. The ultrasound energy generates conformal lesion 209 with said ultrasound energy on a surface of fat lobuli 1307. Conformal lesion 209 creates opening 1321 in the surface of fat lobuli 1307, which allows the draining of a fluid out of fat lobuli 1307 and through opening 1321. Additionally, the method can include targeting at least one fat cell in subcutaneous fat layer 1321 below skin surface 1304 and delivering a second energy to the fat cell. The delivered second energy raises a temperature of the fat cell into a range from about 43° C. to about 49° C., which stimulates apoptosis of the fat cell.

[0134] The method can further include a physical treatment as described herein, as well as the use of a secondary energy source. The method can both reduce the number of fat cells in subcutaneous fat layer 1317 and reduce the appearance of cellulite on skin surface 1304. The method can be effective in the physically breaking fat cell clusters and stretching fibrous bonds of cellulite.

[0135] In accordance with another exemplary embodiment of the present invention, a method of non-invasive treatment of cellulite includes identifying fat lobuli 1307 and creating a sharp focal of ultrasound energy onto fat lobuli 1307. The focal of energy pierces fat lobuli 1307 to create opening 1321, which then allows the flowing of a material out of fat lobuli 1307 through opening 1321. The method can further include any of the additional method steps discussed herein.

[0136] In various embodiments, the energy is delivered at a treatment depth from about 0 mm to about 50 mm or about

1 mm to about 35 mm. The ultrasound energy can be in the range from about 750 kHz to about 20 MHz and may be more useful in the range from about 2 MHz to about 10 MHz. The power of the ultrasound energy may be in a range from about 1 W to about 50 W and may be more useful in the range from about 2 W to about 20 W. The duration of the ultrasound energy may be in the range from about 10 milliseconds to about 20 minutes.

[0137] Once the treatment protocol, for any of the methods of treatment discussed herein or variations thereof, has been implemented, ROI 210 may have one or more reactions to the treatment. For example, in some embodiments, the tissue responds by enhancement of lymphatic drainage, evacuation of fat decay products, creation of a thermal injury and/or coagulation of proximal protrusions of fat lobuli 1307.

[0138] In an exemplary embodiment, energy such as ultrasound energy is emitted from a treatment system at multiple depths to target numerous areas within a specific ROI 210. Multiple layers of tissue within ROI 210 are treated from the surface down to the deepest point of ultrasound energy penetration and no intervening layers of tissue are spared in one embodiment of the present invention. In addition to ultrasound energy, other energy forms such as laser energy, radio frequency energy, and other energies can be used and fall within the scope of the present invention. Further, blue light at a wavelength of approximately 400 to 450 nm can be used to pre-treat ROI 210 before the application of ultrasound energy or blue light of this wavelength can be used with ultrasound to increase the efficacy of treatment. In another embodiment, visible light in the range of 600 to 1350 nm can be used with the ultrasound during treatment.

[0139] Upon treatment, the steps outlined herein can be repeated one or more additional times to provide for optimal treatment results. Different ablation sizes and shapes of conformal lesion 209 may affect the recovery time and time between treatments. For example, in general, the larger the surface area of conformal lesion 209, the faster the recovery. The series of treatments can also enable the user to tailor additional treatments in response to a patient's responses to the ultrasound treatment.

[0140] The methods of treatment described herein can employ various shaped conformal lesions 209 and can be produced using the various acoustic lenses and designs described herein. For example, mushroom shaped lesions may be produced from a spherically-focused source, and/or planar lesions from a flat source. That is, as the application of ablative ultrasound energy continues, this causes thermal expansion to generate a growing lesion. Concave planar sources and arrays can produce a "V-shaped" or ellipsoidal lesion. Electronic arrays, such as a linear array, can produce defocused, planar, or focused acoustic beams that may be employed to form a wide variety of additional lesion shapes at various depths. Other lesion shapes that may be useful with the treatment methods described herein include the lesion shapes and patterns described in the U.S. patents and U.S. patent application that are incorporated by reference herein.

[0141] The citation of references herein does not constitute admission that those references are prior art or have relevance to the patentability of the invention disclosed herein. All references cited in the Description section of the specification are hereby incorporated by reference in their entirety for all purposes. In the event that one or more of the

incorporated references differs from or contradicts this application, including, but not limited to, defined terms, term usage, described techniques, or the like, this application controls.

[0142] The present invention has been described above with reference to various exemplary embodiments. However, those skilled in the art will recognize that changes and modifications may be made to the exemplary embodiments without departing from the scope of the present invention. For example, the various operational steps, as well as the components for carrying out the operational steps, may be implemented in alternate ways depending upon the particular application or in consideration of any number of cost functions associated with the operation of the system, e.g., various steps may be deleted, modified, or combined with other steps. These and other changes or modifications are intended to be included within the scope of the present invention, as set forth in the following claims.

1. (canceled)
2. An ultrasound treatment system for treatment of fat, the system comprising:
  - an ultrasound probe comprising a motion mechanism and a therapy component, the therapy component comprises of:
    - an ultrasound therapy element that delivers ultrasound energy at a frequency of between 2 MHz to 10 MHz, wherein the ultrasound therapy element is a spherically focused element or a cylindrically focused element, wherein the ultrasound therapy element is configured for delivery of energy at a temperature sufficient to coagulate at least a portion of a plurality of fat lobuli at a depth under a skin surface,
    - wherein the ultrasound therapy element is connected to the motion mechanism, and
  - a control system comprising a processor and power supply;
  - wherein the ultrasound probe is configured for acoustic coupling to a skin surface,
  - wherein the ultrasound therapy element is in communication with the control system,
  - wherein the motion mechanism is in communication with the control system,
  - wherein the motion mechanism moves the ultrasound therapy element to form a plurality of thermal foci at the depth for coagulating the at least a portion of the plurality of fat lobuli.
3. The system of claim 2, further comprising:
  - a user control switch to activate the ultrasound therapy element,
  - wherein the ultrasound energy increases the speed at which fat metabolizes according to the Arrhenius Law:  $Y=A \cdot e^{-B/T}$ , where Y is the yield of metabolic reaction, A and B are constants, and T is the temperature in degrees Kelvin.
4. The system of claim 2, further comprising a monitoring system,
  - wherein the monitoring system is configured to monitor a treatment parameter, wherein the treatment parameter measured comprises a temperature of the tissue below the skin surface, and
  - wherein the ultrasound probe further comprises a temperature monitoring sensor.

5. The system of claim 2,
  - wherein the motion mechanism comprises an encoder, wherein the motion mechanism is configured to form a plurality of thermal lesions along a line at the depth in the region of interest by moving the ultrasound therapy element.
6. The system of claim 2, further comprising an acoustic coupler between the ultrasound probe and the skin surface,
  - wherein the motion mechanism comprises an encoder, and wherein the motion mechanism is configured for any one of the group consisting of linear, rotational, and variable movement of the ultrasound therapy element within the ultrasound probe.
7. The system of claim 2,
  - wherein the motion mechanism comprises an encoder for monitoring a position of the ultrasound therapy element on the motion mechanism inside the probe,
  - wherein the ultrasound therapy element is configured to deliver the energy at the depth below the skin surface.
8. The system of claim 2, further comprising a monitoring system,
  - wherein the monitoring system is configured to monitor a treatment parameter, wherein the treatment parameter measured comprises a temperature of the tissue below the skin surface,
  - wherein the ultrasound probe further comprises a temperature monitoring sensor,
  - wherein the therapy element is configured to increase a temperature of the tissue to a range of 43 to 49 degrees Celsius,
  - wherein the ultrasound energy is delivered with a treatment power of between 1 W and 50 W.
9. The system of claim 2, further comprising an ultrasound imaging element and a display.
10. An ultrasound treatment system for treatment of fat, the system comprising:
  - an ultrasound probe comprising a therapy component, wherein the therapy component comprises:
    - a cylindrically focused ultrasound therapy element, wherein the cylindrically focused ultrasound therapy element delivers ultrasound energy at a frequency of between 750 kHz to 20 MHz,
    - wherein the cylindrically focused ultrasound therapy element is configured for delivery of energy at a temperature sufficient to coagulate one or more fat lobuli at a depth under a skin surface, and
  - a motion mechanism;
  - wherein a portion of the ultrasound probe is configured for acoustic coupling to a skin surface; and
  - wherein the cylindrically focused ultrasound therapy element is connected to the motion mechanism,
  - wherein the motion mechanism moves the cylindrically focused ultrasound therapy element to coagulate the fat lobuli.
11. The system of claim 10,
  - wherein the ultrasound probe further comprises an ultrasound imaging element,
  - wherein the ultrasound imaging element is configured for imaging a region of interest under the skin surface, wherein the region of interest comprises the fat lobuli.
12. The system of claim 10,
  - wherein the cylindrically focused ultrasound therapy element delivers ultrasound energy at a frequency of between 2 MHz to 10 MHz, and

wherein the ultrasound energy increases the speed at which fat metabolizes according to the Arrhenius Law:  $Y=A \cdot e^{-B/T}$ , where Y is the yield of metabolic reaction, A and B are constants, and T is the temperature in degrees Kelvin.

**13.** The system of claim **10**,

wherein the cylindrically focused ultrasound therapy element is configured to deliver the energy up to 5.5 cm below the skin surface,

wherein the ultrasound energy is delivered with a treatment power of between 1 W and 50 W.

**14.** An ultrasound treatment system for treatment of fat, the system comprising:

an ultrasound probe comprising a motion mechanism and a therapy component,

wherein the therapy component comprises an ultrasound therapy element,

wherein a portion of the ultrasound probe is configured for acoustic coupling to a skin surface; and

a control system;

wherein the ultrasound therapy element is configured for delivery of energy to a region of interest under the skin surface, wherein the ultrasound therapy element is configured to coagulate at least a portion of the plurality of fat lobuli at a depth under the skin surface,

wherein the ultrasound therapy element is connected to the motion mechanism,

wherein the motion mechanism moves the ultrasound therapy element to form a plurality of thermal lesions at the at least the portion of the plurality of fat lobuli at the depth for reducing the appearance of fat.

**15.** The system of claim **14**,

wherein the therapy element delivers ultrasound energy at a frequency of between 2 MHz to 10 MHz,

wherein the ultrasound therapy element is configured to deliver the energy at the depth below the skin surface.

**16.** The system of claim **14**, wherein the ultrasound energy is configured for heating the plurality of fat lobuli to a temperature in a range of 43 to 49 degrees Celsius.

**17.** The system of claim **14**, further comprising a monitoring system,

wherein the monitoring system is configured to monitor a treatment parameter, wherein the treatment parameter measured comprises a temperature of the tissue below the skin surface,

wherein the ultrasound probe further comprises a temperature monitoring sensor,

wherein the control system comprises a spatial control and a temporal control, the spatial control and the temporal control controlling the delivery of energy to heat the plurality of fat lobuli at the depth under the skin surface

**18.** The system of claim **14**, further comprising a user control switch to activate the ultrasound therapy element and wherein the ultrasound energy increases the speed at which fat metabolizes according to the Arrhenius Law:  $Y=A \cdot e^{-B/T}$ , where Y is the yield of metabolic reaction, A and B are constants, and T is the temperature in degrees Kelvin.

**19.** The system of claim **14**, wherein the control system comprises: an input device and a power supply.

**20.** The system of claim **14**, wherein the therapy element is a spherically focused single element.

**21.** The system of claim **14**, wherein the therapy element is a cylindrically focused single element.

\* \* \* \*

专利名称(译)	基于能量的脂肪减少		
公开(公告)号	<a href="#">US20170095680A1</a>	公开(公告)日	2017-04-06
申请号	US15/380267	申请日	2016-12-15
申请(专利权)人(译)	引导治疗系统公司		
当前申请(专利权)人(译)	引导治疗系统公司		
[标]发明人	SLAYTON MICHAEL H BARTHE PETER G		
发明人	SLAYTON, MICHAEL H. BARTHE, PETER G.		
IPC分类号	A61N7/00 G01S7/52 B06B1/06 G01S15/89 A61B5/00 A61B8/08		
CPC分类号	A61N7/00 A61B5/4869 A61B8/0858 B06B1/0607 A61B2090/378 G01S7/5208 A61N2007/0008 A61N2007/0052 A61N2007/027 G01S15/899 A61B8/14 A61B8/429 A61B8/4455 A61B8/4483 A61B8 /483 A61N7/02 B06B1/0622 G01S15/8906 G01S15/8993 H05K999/99		
优先权	60/616753 2004-10-06 US 61/140725 2008-12-24 US		
其他公开文献	US9713731		
外部链接	<a href="#">Espacenet</a> <a href="#">USPTO</a>		

摘要(译)

用于非侵入性减脂的方法可以包括靶向皮肤表面下方的感兴趣区域，其含有脂肪并将超声能量输送到感兴趣区域。超声能量在脂肪细胞上产生具有所述超声能量的热损伤。病变可以在脂肪细胞的表面产生开口，这允许将流体排出脂肪细胞并通过开口。另外，通过对脂肪细胞施加超声能量，将温度升高到43度~49度，可以实现细胞凋亡，从而减少脂肪。

