



US 20160106370A1

(19) **United States**
(12) **Patent Application Publication**
Filipovic et al.

(10) **Pub. No.: US 2016/0106370 A1**
(43) **Pub. Date: Apr. 21, 2016**

(54) **PERSONAL CLOUD WITH A PLURALITY OF MODULAR CAPABILITIES**

(71) Applicant: **Micro Mobio Corporation**, Palo Alto, CA (US)

(72) Inventors: **Zlatko Aurelio Filipovic**, San Jose, CA (US); **Weiping Wang**, Palo Alto, CA (US); **Adam James Wang**, Palo Alto, CA (US)

(21) Appl. No.: **14/961,862**

(22) Filed: **Dec. 7, 2015**

Related U.S. Application Data

(63) Continuation-in-part of application No. 14/036,729, filed on Sep. 25, 2013, now Pat. No. 9,207,715, which is a continuation-in-part of application No. 13/831,663, filed on Mar. 15, 2013, now Pat. No. 9,086,847.

(60) Provisional application No. 61/705,383, filed on Sep. 25, 2012.

Publication Classification

(51) **Int. Cl.**
A61B 5/00 (2006.01)
H04B 1/3827 (2006.01)

A61B 5/11 (2006.01)
A61B 3/14 (2006.01)
A61B 5/0404 (2006.01)
A61B 5/01 (2006.01)
H04B 1/3888 (2006.01)
H04M 1/02 (2006.01)

(52) **U.S. Cl.**
CPC *A61B 5/6898* (2013.01); *H04B 1/3888* (2013.01); *H04B 1/385* (2013.01); *H04M 1/0254* (2013.01); *A61B 3/14* (2013.01); *A61B 5/0404* (2013.01); *A61B 5/742* (2013.01); *A61B 5/748* (2013.01); *A61B 5/01* (2013.01); *A61B 5/6831* (2013.01); *A61B 5/1112* (2013.01); *A61B 2560/0252* (2013.01); *A61B 2560/0257* (2013.01); *A61B 2562/0219* (2013.01)

(57) **ABSTRACT**

A personal cloud structure for a portable computing device such as a tablet personal computer (PC), mobile phones, portable media players, or the like. The personal cloud structure may be fitted with memory, a network connection, two-way wireless charging, external memory slots, external connections and other components to create a portable personal cloud.

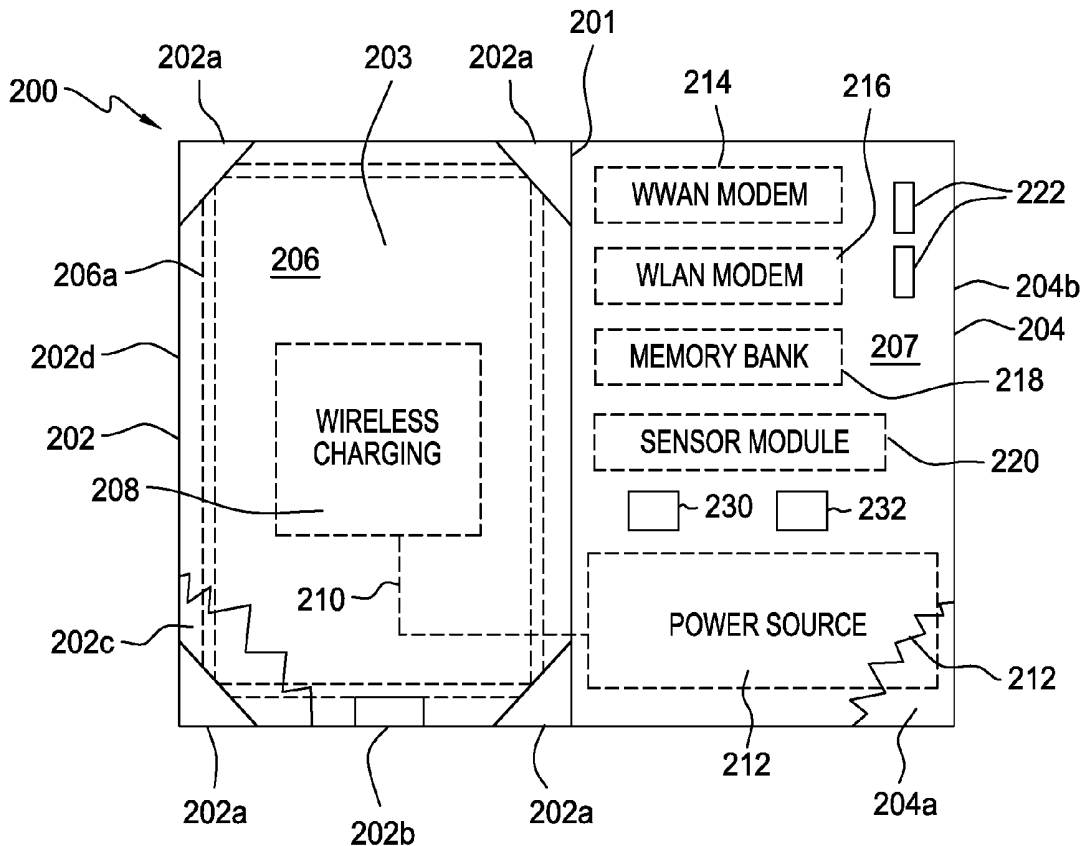

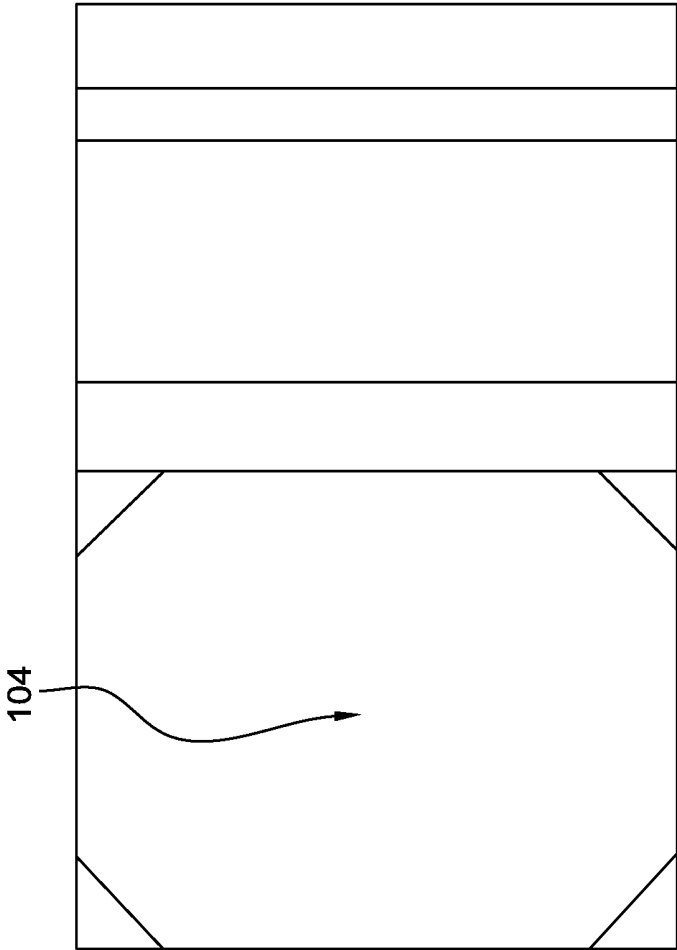

FIG. 1B

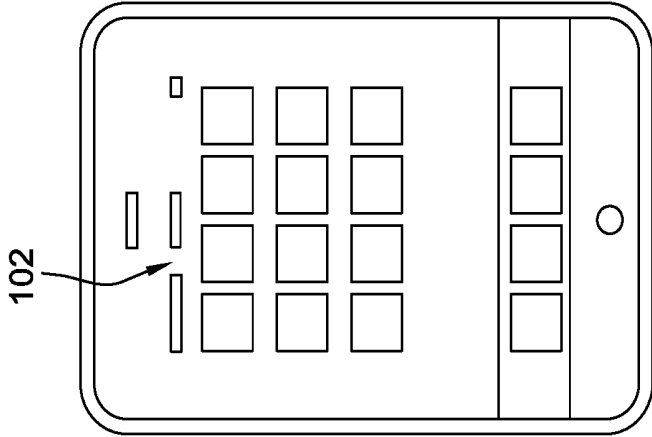

FIG. 1A

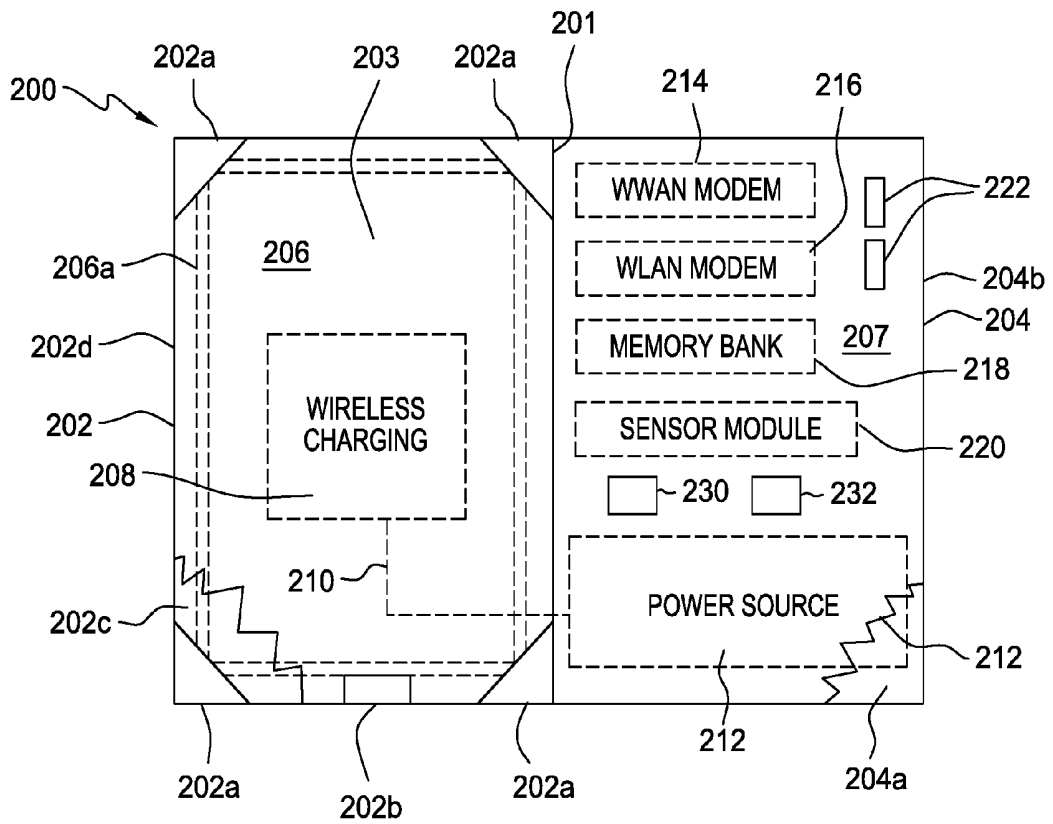

FIG. 2A

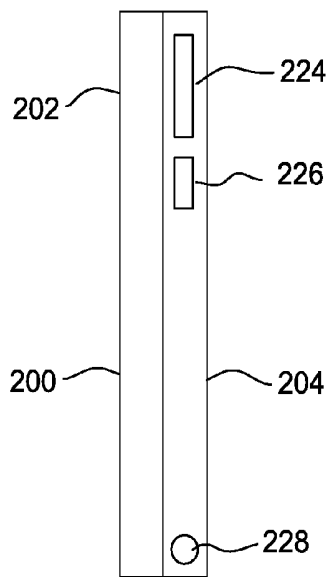

FIG. 2B

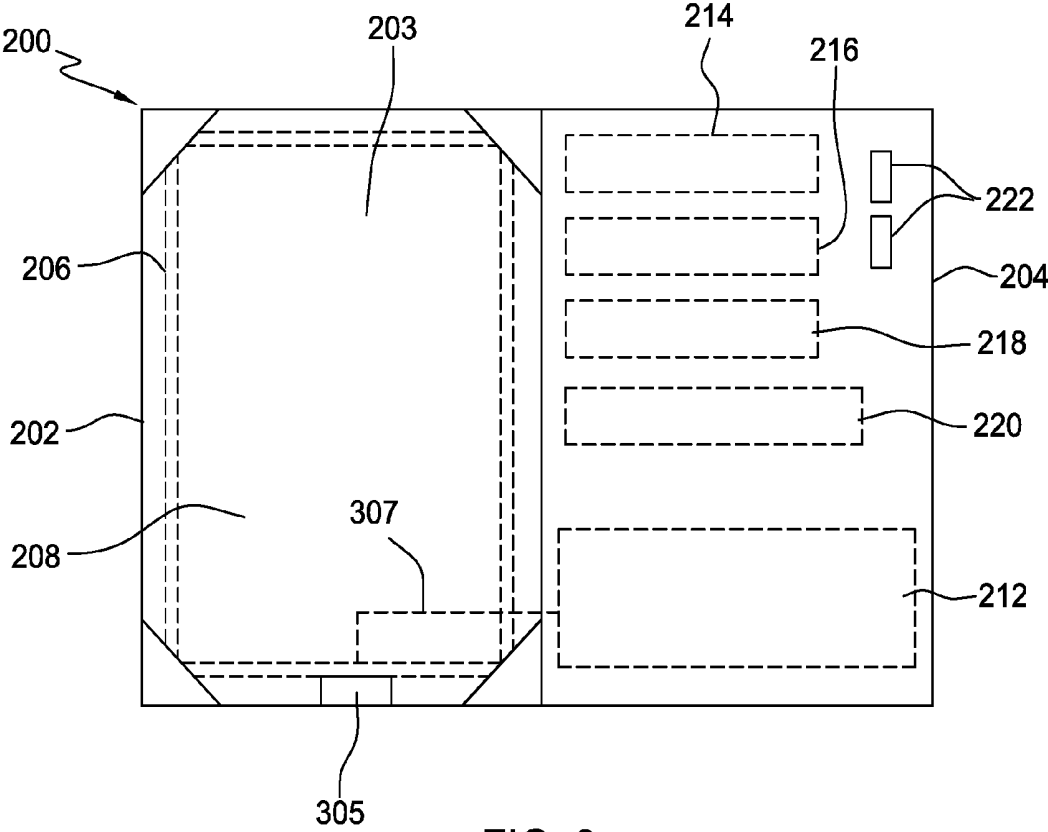

FIG. 3

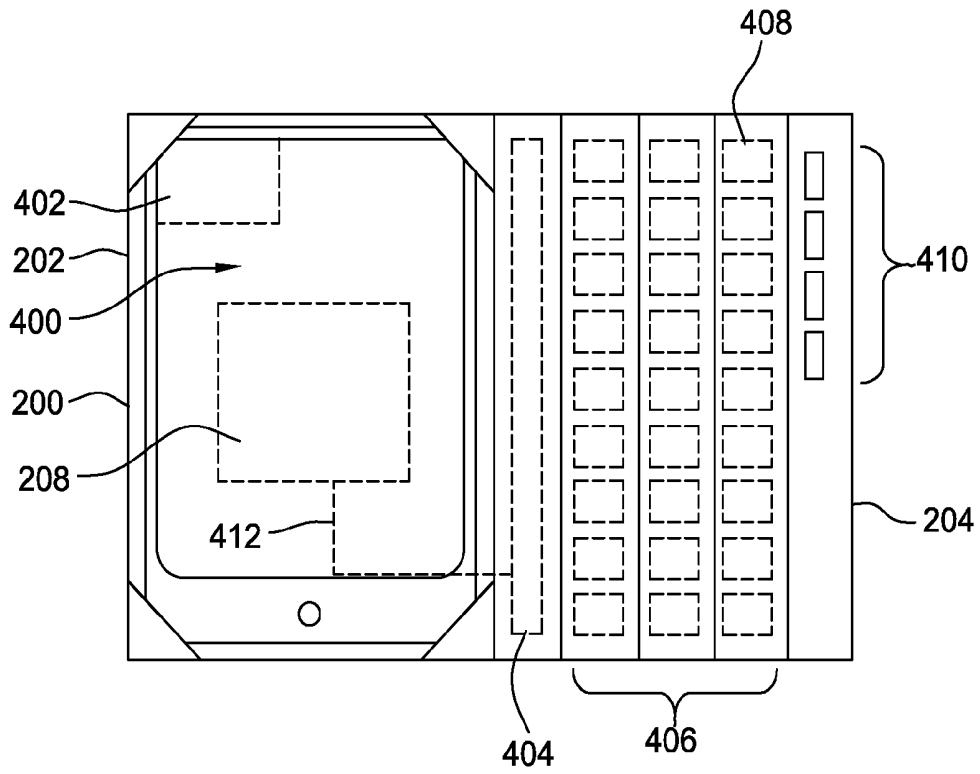

FIG. 4

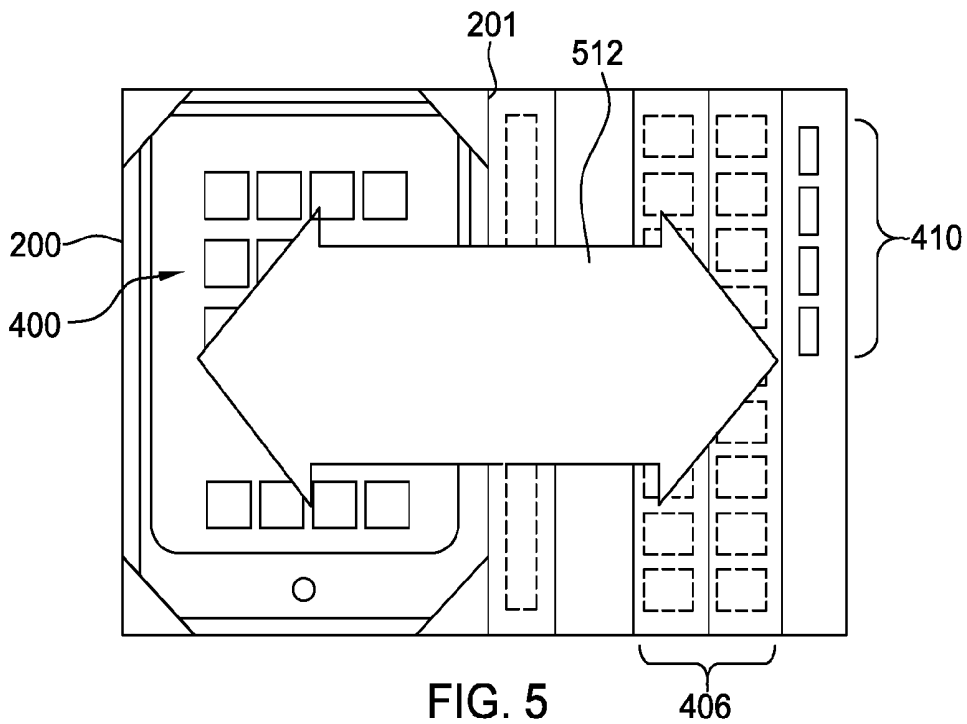

FIG. 5

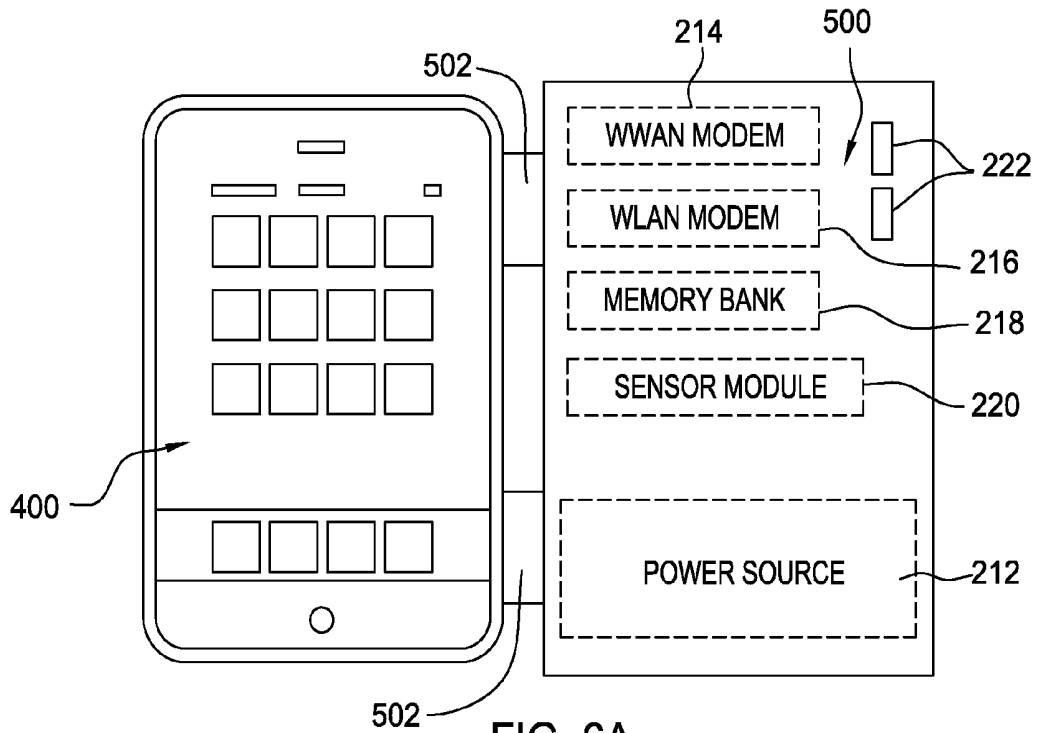

FIG. 6A

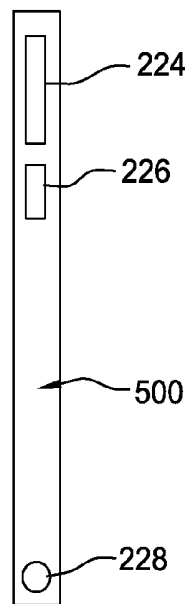

FIG. 6B

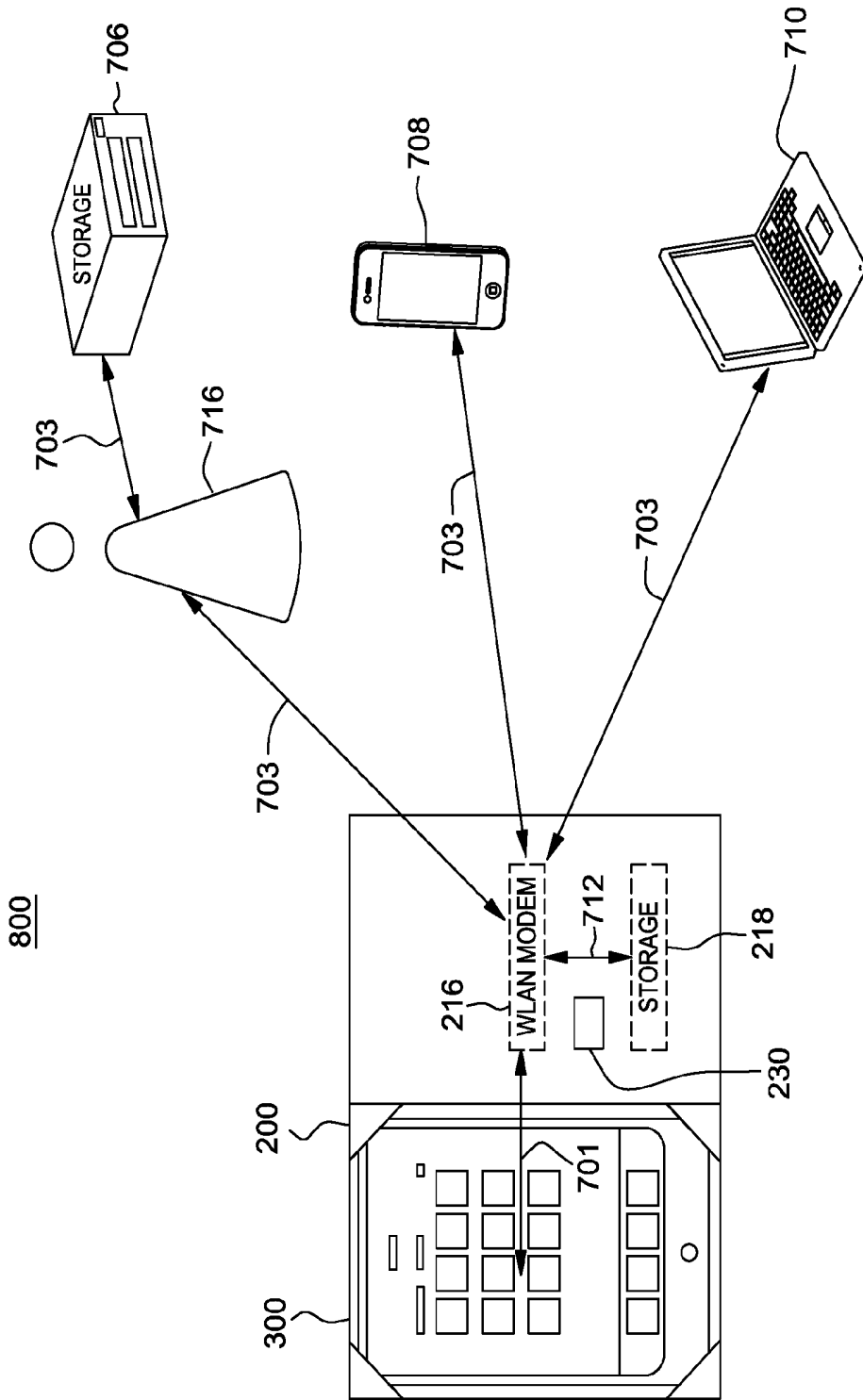

FIG. 8

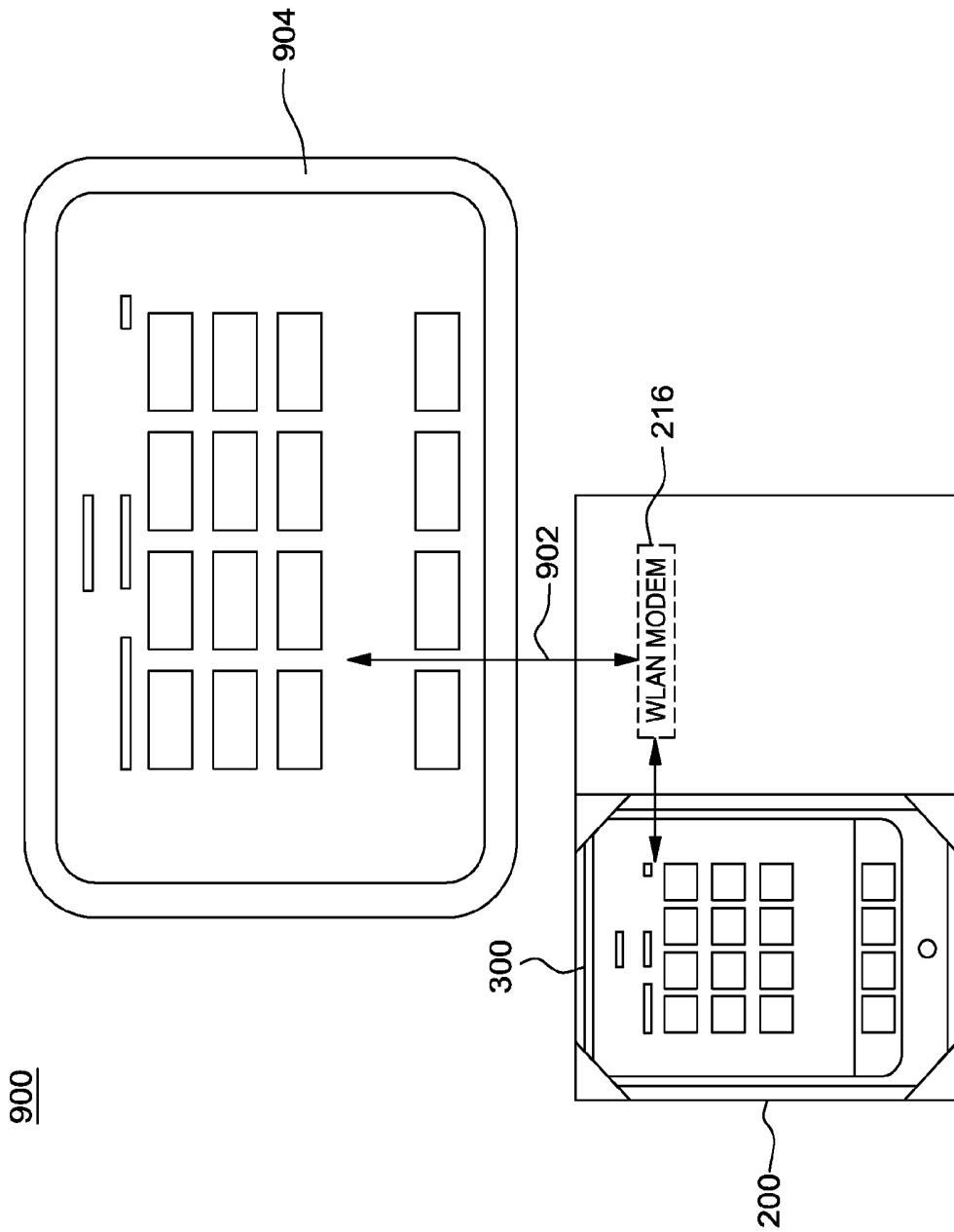

FIG. 9

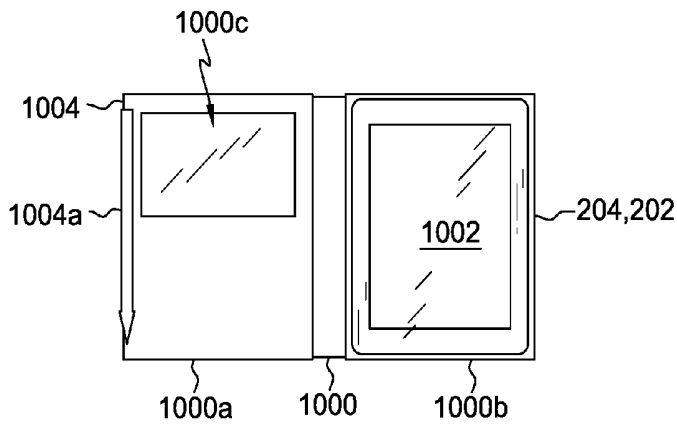

FIG. 10

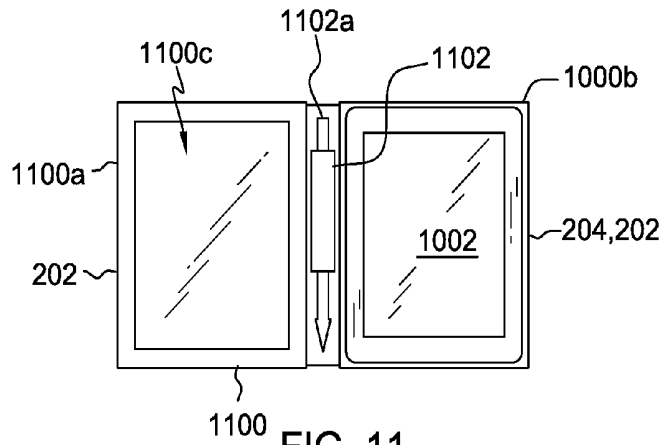

FIG. 11

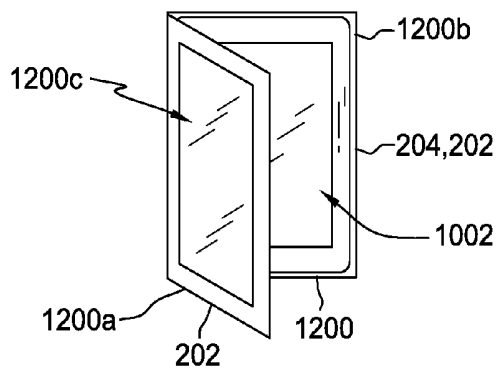

FIG. 12

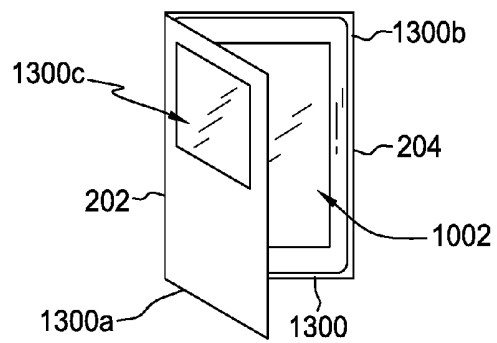

FIG. 13

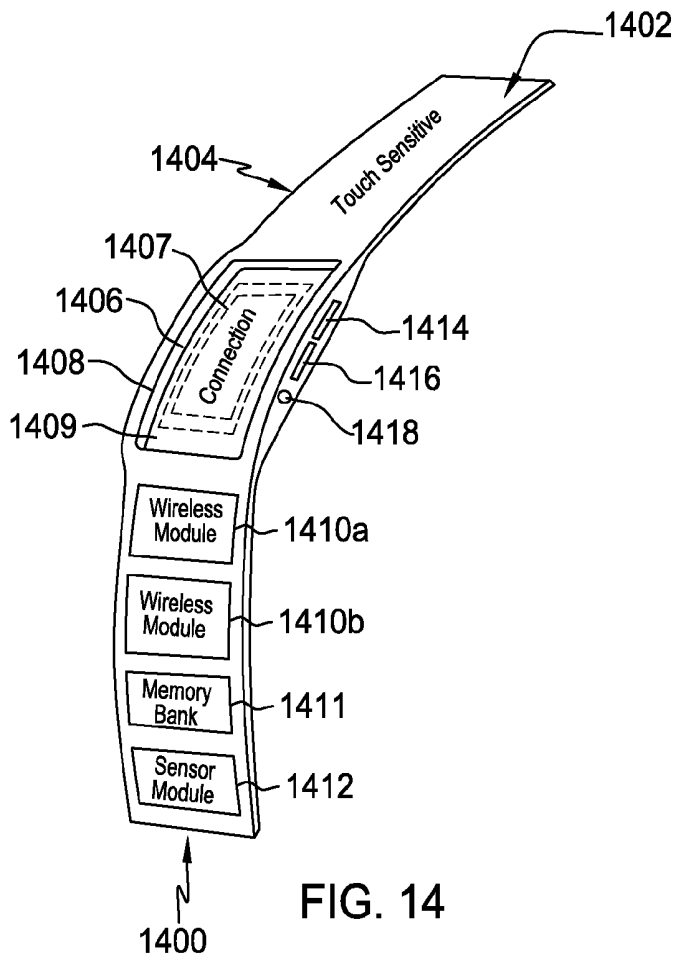

FIG. 14

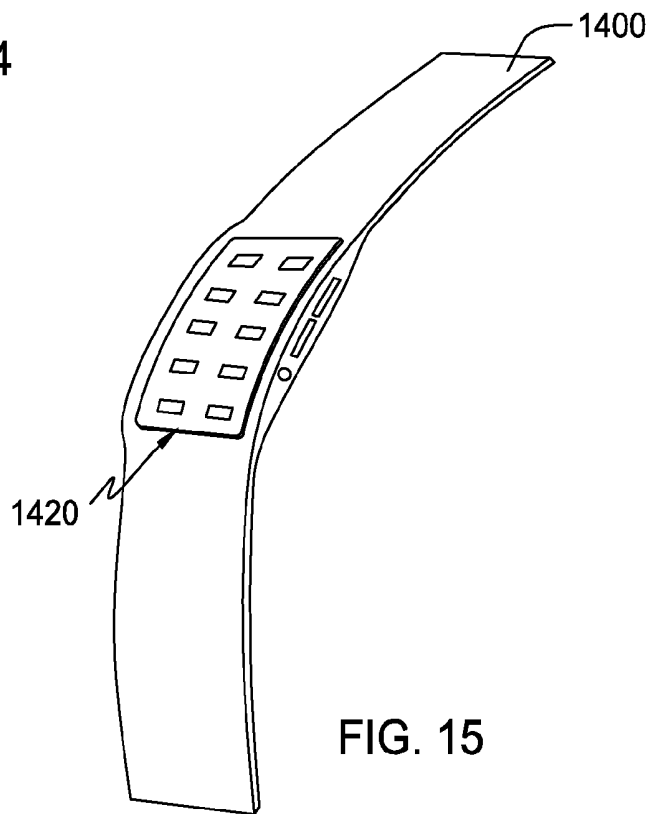

FIG. 15

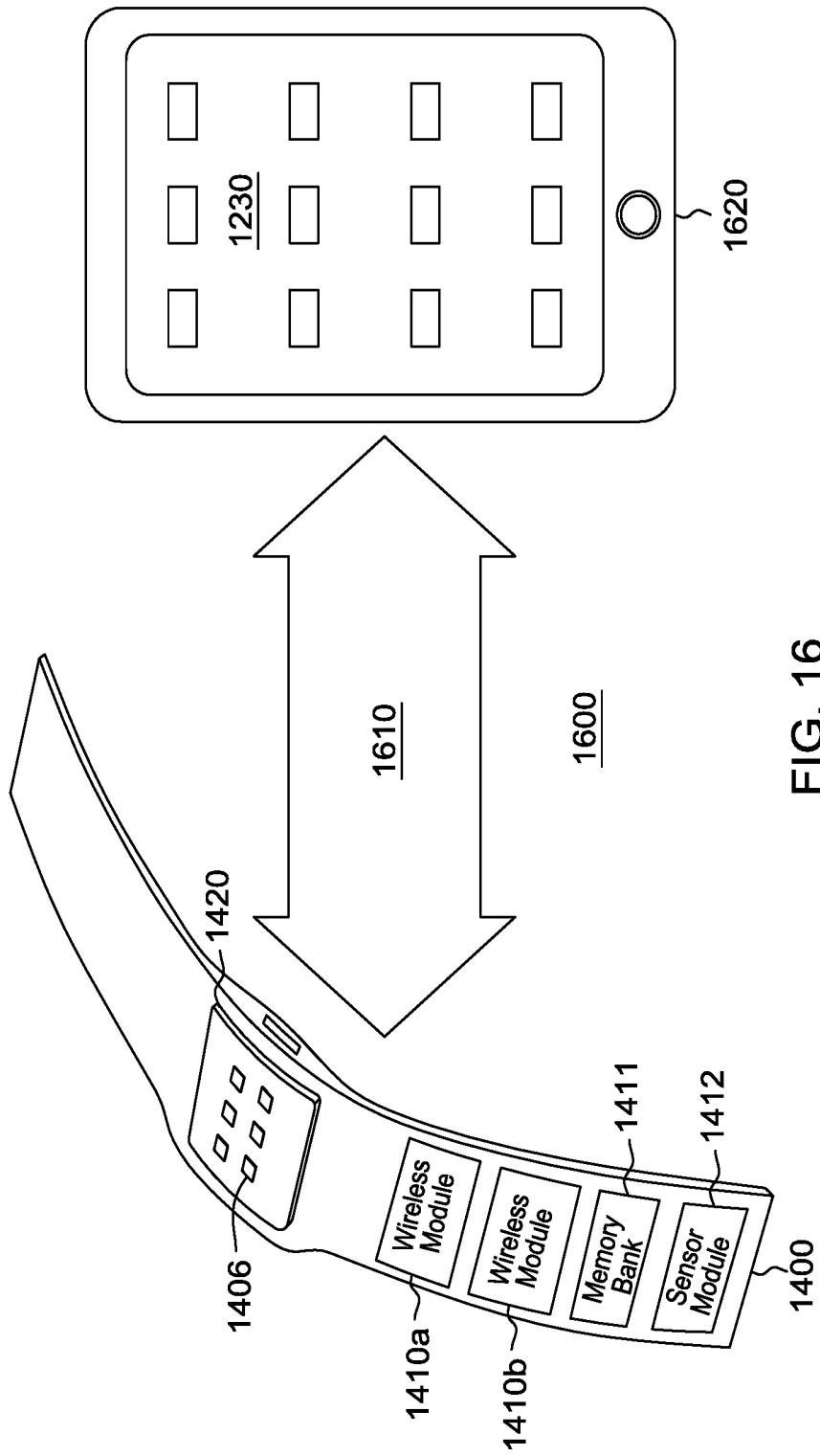

FIG. 16

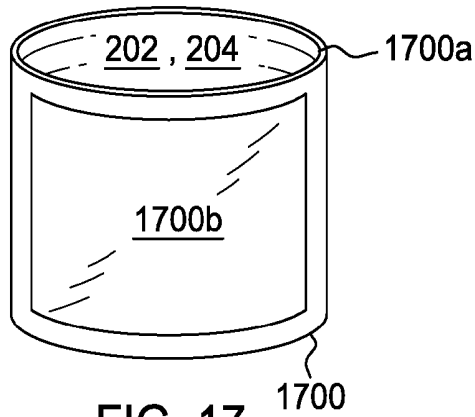

FIG. 17

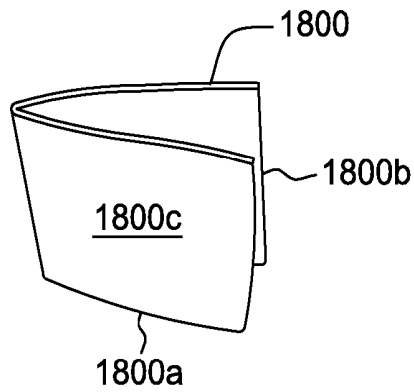

FIG. 18A

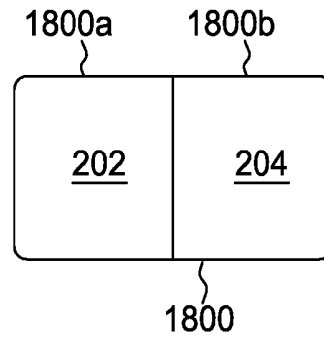

FIG. 18B

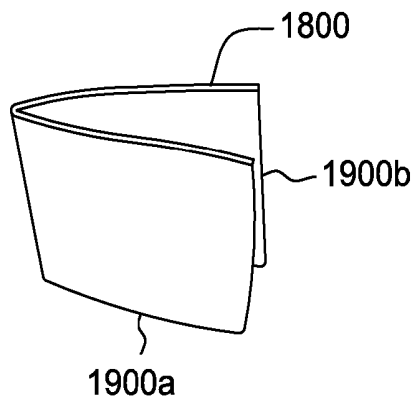

FIG. 19A

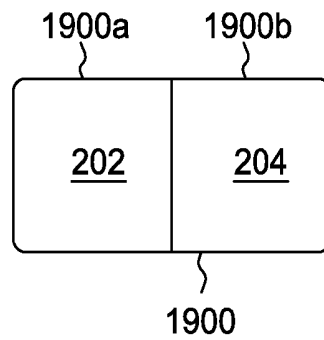

FIG. 19B

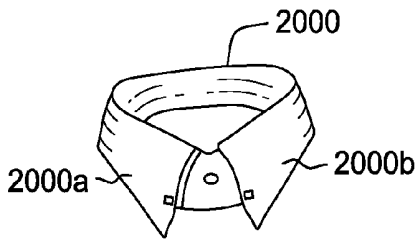

FIG. 20A

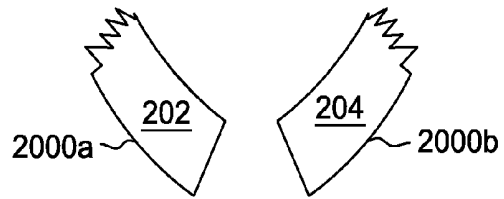

FIG. 20B

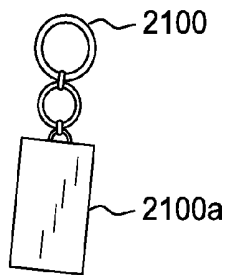

FIG. 21A

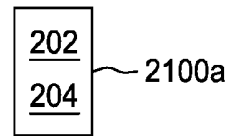

FIG. 21B

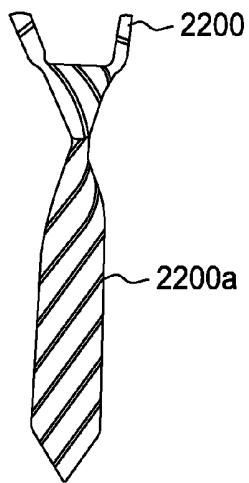

FIG. 22A

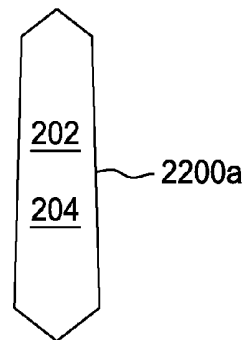

FIG. 22B

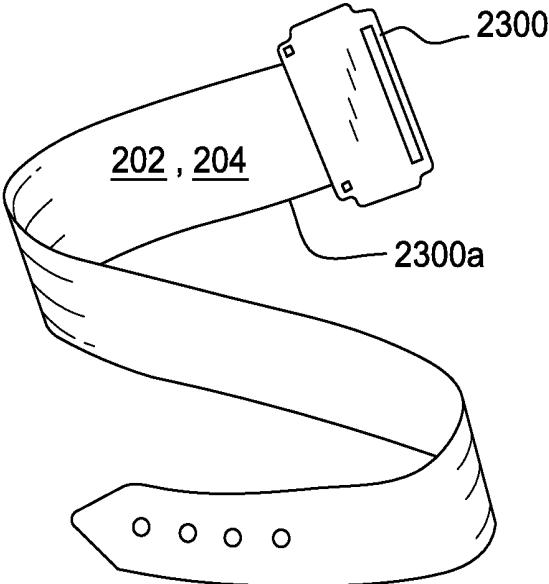

FIG. 23

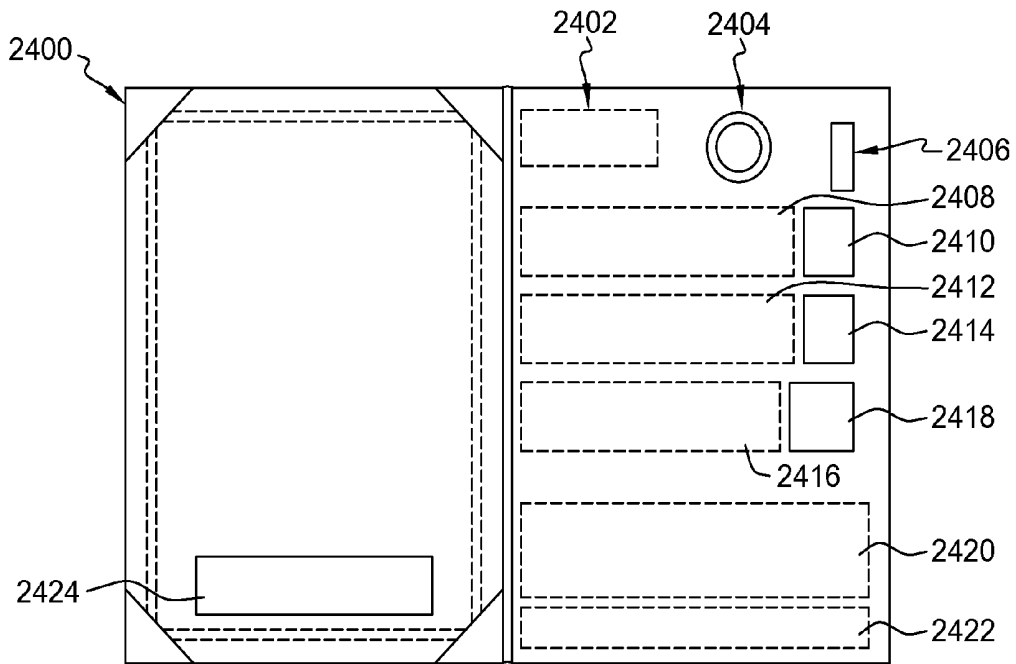

FIG. 24

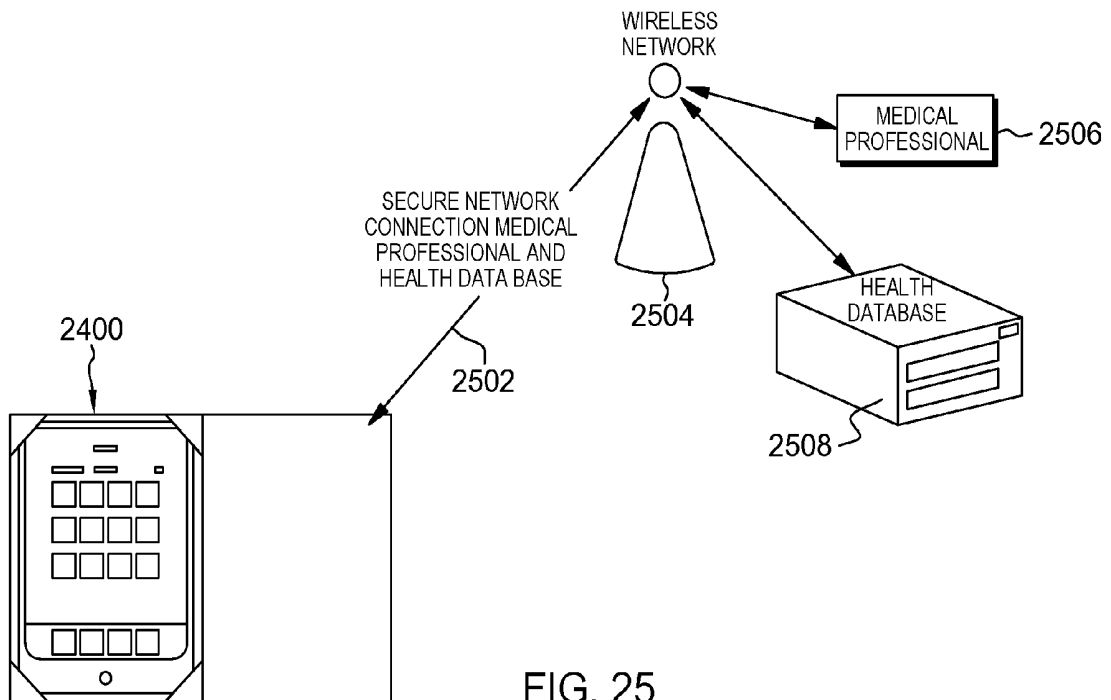

FIG. 25

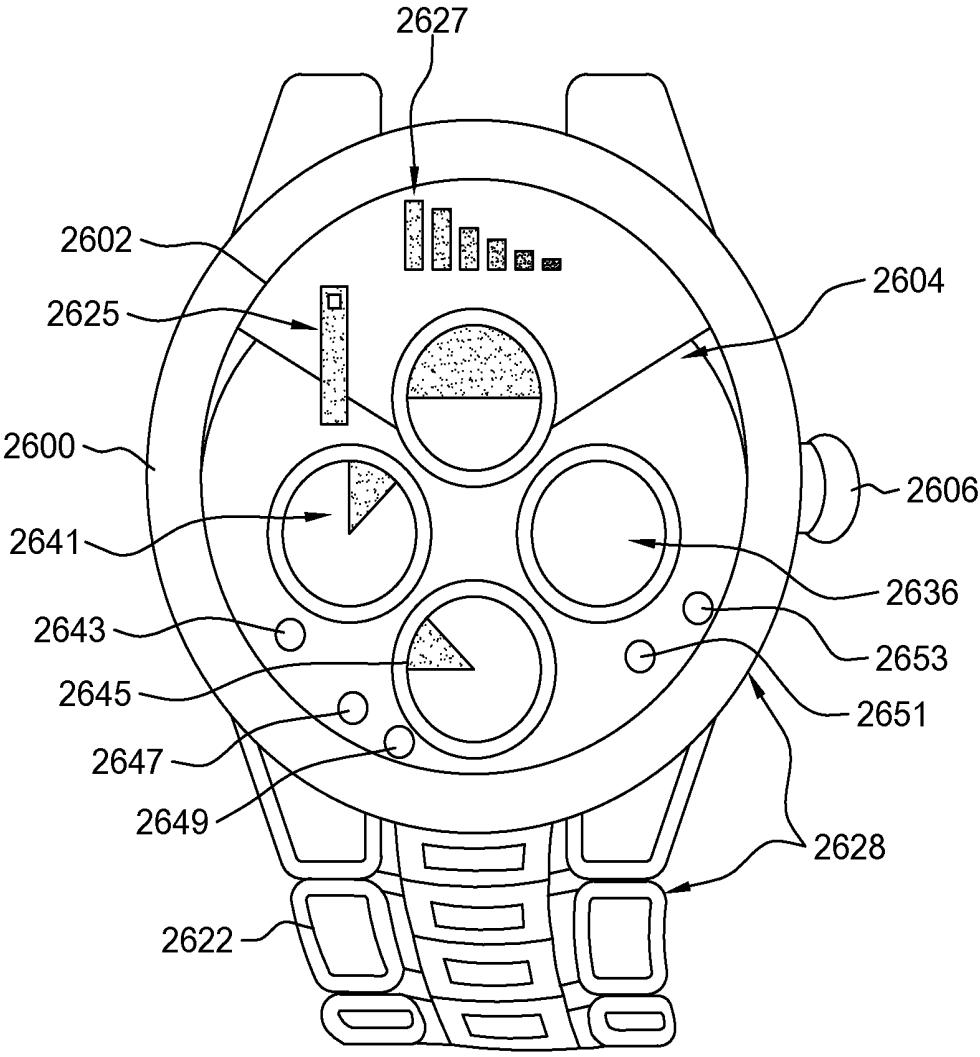

FIG. 26

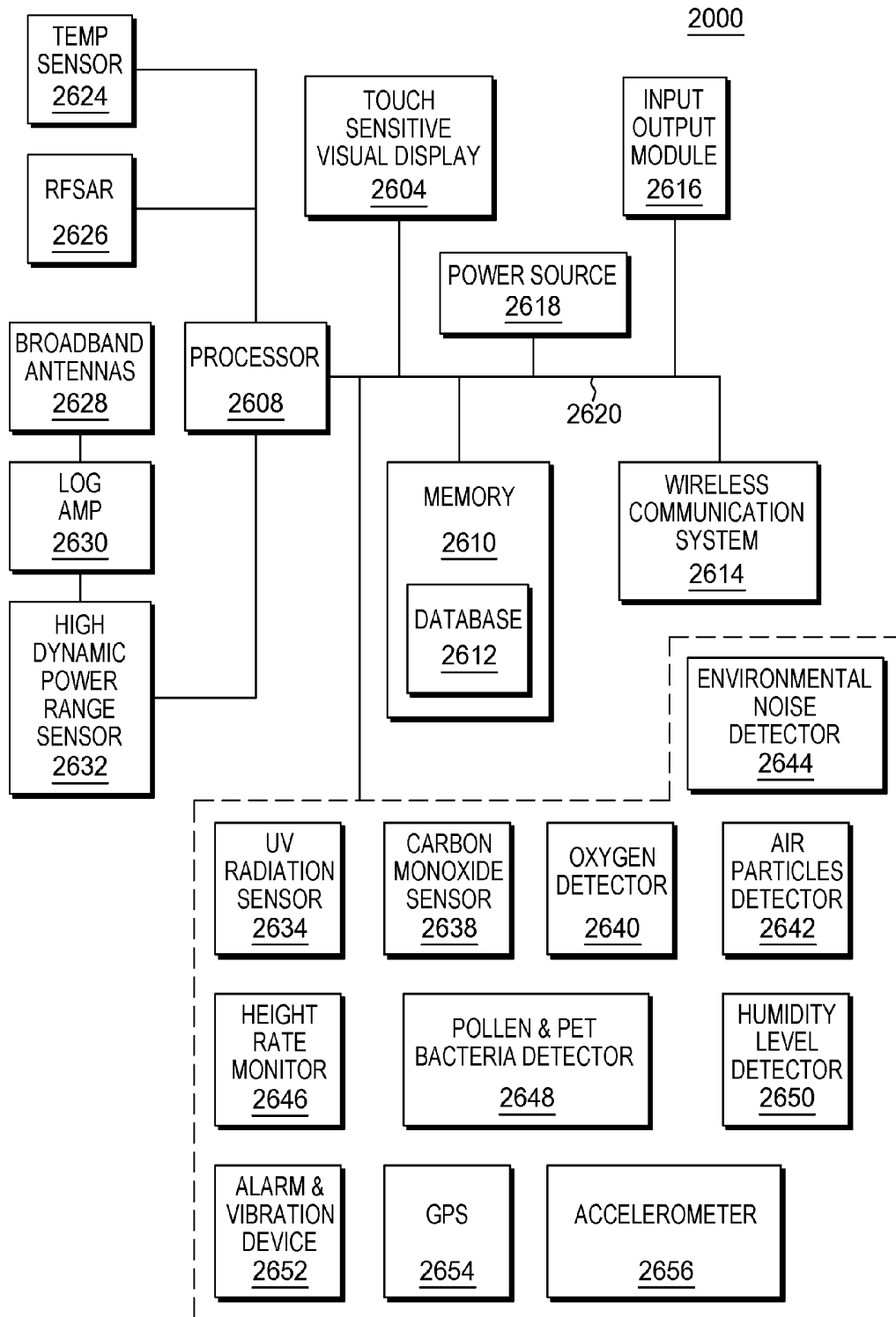
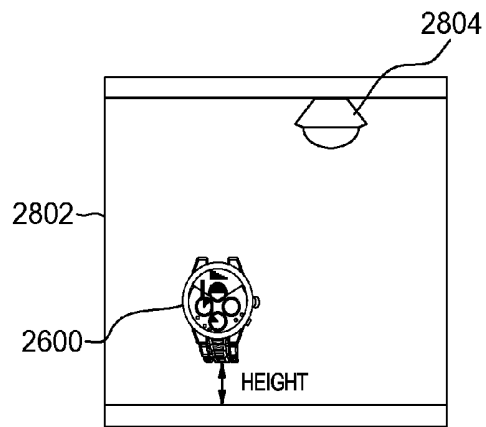
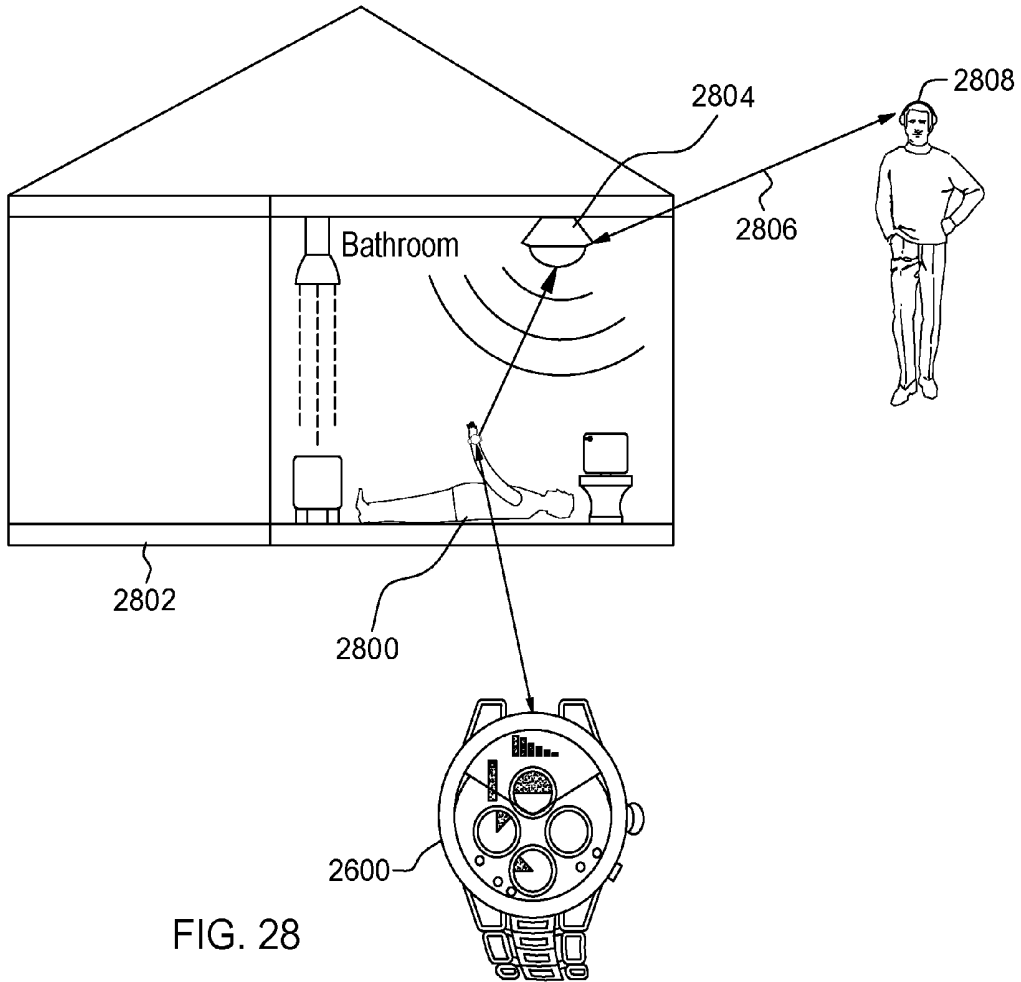

FIG. 27



PERSONAL CLOUD WITH A PLURALITY OF MODULAR CAPABILITIES

PRIORITY CLAIM

[0001] This patent application is a continuation-in-part of U.S. patent application Ser. No. 14/036,729, filed Sep. 25, 2013, which claims the benefit of U.S. patent application Ser. No. 13/831,663, filed Mar. 15, 2013, and further claims priority to the U.S. provisional patent application having Ser. No. 61/705,383, filed Sep. 25, 2012; the aforementioned applications being incorporated herein by reference in their entirety.

FIELD OF THE DISCLOSURE

[0002] The present disclosure relates generally to a system and method of mobile computing and, in particular, in one or more embodiments, the present disclosure relates to structures having a plurality of modular capabilities.

BACKGROUND

[0003] There are presently a wide variety of portable electronic devices **102** as disclosed in FIG. 1A. The portable electronic devices may include cellphones such as the iPhone®, Nexus, Lumia and the like and tablet personal computers (PCs) such as the iPad®, Kindle® and similar type devices. These portable electronic devices are often protected by a simple case cover **104** as disclosed in FIG. 1B. These prior art case covers **104** typically do not contain any functional components beyond the protective cover itself.

SUMMARY

[0004] Aspects of the embodiments disclosed herein include a structure configured to connect to a mobile computing device comprising: a cavity capable of holding the mobile computing device; a power source coupled to the cavity and to a plurality of modules located in the structure and capable of providing power to the plurality of modules; and wherein the plurality of modules include at least one of a plurality of wireless modems which allows the case to wirelessly transmit and receive signals from other electronic devices.

[0005] Other aspects of the embodiments disclosed herein is a case for a mobile communication device comprising: a first panel and a second panel capable of forming a compartment for the mobile computing device; said first panel having a screen; a power source connected to a plurality of modules located on at least one of the first and second panels and capable of providing power to the plurality of modules; and wherein the plurality of modules include a WWAN modem and a WLAN modem which allows the case to wirelessly transmit and receive signals from other electronic devices.

BRIEF DESCRIPTION OF THE DRAWINGS

[0006] FIG. 1A is a front view of a prior art mobile computing device.

[0007] FIG. 1B is a front view of a prior art simple case cover for a mobile computing device.

[0008] FIG. 2A is a front view of a personal cloud case cover (PCCC).

[0009] FIG. 2B is a side view of the PCCC of FIG. 2A.

[0010] FIG. 3 is a front view of a second embodiment of the PCCC.

[0011] FIG. 4 is a front view of a third embodiment of the PCCC.

[0012] FIG. 5 is a front view of a fourth embodiment of the PCCC.

[0013] FIG. 6A is a front view of a fifth embodiment of the PCCC.

[0014] FIG. 6B is a side view of the PCCC of FIG. 6A.

[0015] FIG. 7 is a schematic diagram of a PCCC in a cloud/networked environment utilizing 3G, 4G and similar wireless connections.

[0016] FIG. 8 is a schematic diagram of the PCCC in another cloud/networked environment system.

[0017] FIG. 9 is a view of the PCCC operating with a large external monitor.

[0018] FIG. 10 is a front view of another embodiment **1000** of the PCCC which has a window in the left panel.

[0019] FIG. 11 illustrates an embodiment of the PCCC which has an embedded screen mounted on the left panel cover.

[0020] FIG. 12 illustrates an embodiment of the PCCC which has an embedded screen mounted on the outside of the left panel cover with the mobile device mounted in the right panel.

[0021] FIG. 13 shows a similar embodiment of the PCCC to that of FIG. 12 with an embedded screen also mounted on the outside of the left panel with the mobile device mounted on the right panel.

[0022] FIG. 14 illustrates an embodiment which operates in a manner similar to the other embodiments of the PCCC disclosed above in the discussions of FIGS. 2A-13 but instead the electronic components are mounted on a structure such as a band instead of a case.

[0023] FIG. 15 shows detachably mounted on a structure a mobile wireless computing device which functions like (and may actually be) an iPad®, iPhone®, PC tablet, Android® based tablet, TouchPad, Nexus 7®, Slate® or the like.

[0024] FIG. 16 illustrates the embodiment of FIG. 14 operating in a cloud environment allowing the mobile communication device to link to an external device.

[0025] FIG. 17 illustrates an embodiment of the PCCC which has a screen mounted on a band such as a bracelet or sweatband.

[0026] FIGS. 18A and 18B illustrate an embodiment of the PCCC which have a screen mounted on a wallet.

[0027] FIGS. 19A and 19B illustrate an embodiment of the PCCC which have a wallet shape.

[0028] FIGS. 20A and 20B illustrate an embodiment of the PCCC which has a collar shape.

[0029] FIGS. 21A and 21B illustrate an embodiment of the PCCC which has a key chain shape.

[0030] FIGS. 22A and 22b illustrate an embodiment of the PCCC which has a tie shape.

[0031] FIG. 23 illustrates an embodiment of the PCCC which has a belt shape.

[0032] FIG. 24 illustrates an embodiment of the case cover having a medical health function.

[0033] FIG. 25 illustrates the medical health case cover operating in a cloud environment.

[0034] FIG. 26 is an environmental sensor having a plurality of environmental and physical detection functions.

[0035] FIG. 27 is a block diagram of the circuitry of the environmental sensor.

[0036] FIG. 28 is a schematic of the environmental sensor operating in a networked environment.

[0037] FIG. 29 is a close up schematic of the environmental sensor indicating a fall determined by its height and location.

DETAILED DESCRIPTION

[0038] Although particular aspects or features of the following disclosure may be described with reference to one or more particular embodiments and/or drawings, it should be understood that such features are not limited to usage in the one or more particular embodiments or drawings with reference to which they are described, unless expressly specified otherwise. The functionality and/or the features of the embodiments that are described may be alternatively embodied by one or more other devices which are described but are not explicitly described as having such functionality/features.

[0039] Current mobile computing device covers are limited in their functionality by mainly providing protection from environmental shocks for mobile computing devices. However, the personal cloud cover case (or "PCCC") as disclosed in this application by providing electronic component accessories and functionalities to the cover case enhances the ability of a mobile computing device located inside the PCCC to provide cloud computing services. (Note: the acronym PCCC may be used herein with regard to the descriptions of FIGS. 14 through 23 to cover similar devices to the personal cloud cover case but not just in the shape of a case cover but rather a wallet, band, collar, key chain, tie, etc.). Cloud computing is the use of computing resources that are delivered as a service over a network (such as the Internet) and which reside in the "cloud". The mobile computing device in the case could be an iPad®, iPhone®, PC tablet, Android® based tablet, Touch-Pad, Nexus 7®, Slate® or the like.

[0040] FIG. 2A is a front view of a PCCC 200 which is shown in an open position. The case 200 provides a personal cloud to the user and access to a wireless network (such as 3G, 4G, WiFi, SuperWifi, and similar technologies) of a mobile computing device (not shown) stored in the case 200. The case 200 may be made of any material (hard and/or soft) that makes the case lightweight but durable and resilient such as plastic, silicone, ceramic, fabric, leather, steel, aluminum, fiberglass, titanium, Kevlar, or rubber. The case 200 could be a continuous piece of material with a flexible (or bendable) area 201 located between two opposing panels (first panel 202 and second panel 204) which pivot together around a compartment 203 for containing the mobile computing device. In an alternative embodiment, the case 200 could be made up of plurality of attached sections (201, 202 and 204). First panel 202 also has 4 sleeves 202a to hold the mobile computing device in place in the case 200. In alternative embodiments, the mobile computing device could be attached to the PCCC 200 using a plurality of magnets (instead of the sleeves 202a) positioned under the mobile device, rubber straps or other similar attachment methods.

[0041] The first panel 202 is constructed in layers and includes inner first panel layer 202c, outer first panel layer 202d and embedded circuit board 206. Typically, from the front view the circuit board 206 cannot be seen since it is located underneath the first panel layer 202c shown in cut-away but which is designed to cover substantially the entire first panel 202. An antenna 206a is located on the circuit board 206 and may be in contact with the mobile communication device wirelessly, through physical contact or by connector 202b. Connector 202b is optional and in alternative embodiments it would not be present. The antenna 206a will allow for better transmission and reception on the part of the

mobile communication device. The antenna 206a can be a "chip" antenna, printed circuit board (PCB) antenna or the like covering a plurality of wireless bands (e.g., 400 MHz-3.6 GHz). Alternatively, a PCB antenna may be used, and the antenna 206a will be printed directly onto the circuit board 206. Also located on the board 206 is a two-way wireless charging unit 208 which is in substantial proximity to the resting place of the mobile communication device in the cover 200. The charging unit 208 may be designed such that when the mobile communication device is in proximity to the charging unit an electromagnetic field generated by the charging unit pulls the communication device into proper position and alignment for optimal charging (i.e., charging coil alignment). The wireless charging unit 208 is connected through a bidirectional electrical link 210 to power source 212 located on a circuit board 207 embedded in the second panel 204. The bidirectional electrical link 210 is an example of the plurality of electrical connections that are made throughout the case 200 but which are not necessarily shown in the Figures. Link 210 might be in the form of a ribbon cable so as not to be damaged with the opening and closing of the case 200. The wireless charging unit 208 is capable of wirelessly charging the mobile communication device with power received from the power source 212 or wirelessly receive power from the mobile communication device and transfer it to the power source 212. The wireless charging unit 208 may operate by magnetic resonance, inductive charging, or power over radio frequency (RF) or similar wireless charging methods. The power source 212 is used to power the plurality of components located throughout the cover 200 and, as described, can also be used as a backup battery for the mobile computing device when the voltage in the battery of the mobile computing device falls below a predetermined level.

[0042] The second panel 204 can be made up of an inner second panel 204a and an outer second panel 204b containing the embedded circuit board 207 but which typically cannot be seen from a front view since it is covered by inner second panel layer 204a. The inner second panel layer 204a covers substantially the entire second panel 204 but is only partially shown in cutaway so as to illustrate the components mounted on the circuit board 207 in the outer second panel 204b. It should be understood that the inner second panel layer 204a and the outer second panel layer 204b can be coupled together by a variety of methods such as ultrasonic bonding, mechanical fasteners, adhesives, or solvents. In alternative embodiments, the inner second panel 204a may be entirely or substantially detachable from the outer second panel 204b; the inner second panel 204a may be a closure flap that is fastened close by means of adhesive, a snap button, or Velcro or the inner second panel 204a may not be present at all so as to allow easy access to the components mounted on the board 207 in the outer second panel 204b. The case 200 may further be made up of a plurality of modules 214, 216, 218 and 220 mounted on the circuit board 207 which allow the PCCC 200 to have multi-functional capability. The modules may be made of low profile components which help minimize the thickness of the cover. The plurality of modules may be permanently mounted, may snap-in to the board 207 or may be some combination thereof. First module 214 may include a wireless wide area network modem (WWAN). The WWAN could include baseband, a radio frequency integrated circuit (RFIC), a radio frequency front-end module (RF FEM), Envelope Tracking (ET), Power Management IC (PMIC), and other connected components to link the mobile comput-

ing device to a mobile network such as a 3G, 4G or future generation network. Second module 216 may include a wireless local area network (WLAN) modem for a mobile computing device to connect to a local router and then to 2G, 3G and 4G networks. The WLAN modem can be baseband, RFIC, RF FEM and other connectivity components. The case 200 may contain near field communications (NFC) technology which may be used for contactless shortrange communications based on RF identification standards (RFID) using magnetic field induction to enable communication between the electronic components in the case 200 over short distances such as a few centimeters. In other embodiments, the WLAN modem connection could be made using wireless protocols such as WiFi, SuperWiFi (i.e., the next generation WiFi with superior range), Bluetooth, wireless for high definition multimedia interface (WHDMI), or the like. Third module 218 may be internal storage such as solid-state drives (SSD) or flash memory (e.g., MultiMedia Card (MMC), electronic MMC (eMMC) or the like). Fourth module 220 may contain a sensor chip that is able to detect biometrics inputs such as finger prints, eye movement, face shape, and the like. Module 220 can be used for functions such as a security feature for allowing or denying access to the electronic components in the case, gaming, and medical purposes (e.g., measuring blood cell count and the like). The second panel 204 may also include a smart feature such as a synchronization input 230 (e.g., such as a button, touch screen, or the like) that allows the plurality of electronic components (e.g., module 218) in the PCCC 200 to be synched to other networked devices in the cloud when operated. This input 230 would primarily be used when a mobile communication device is not present in the PCCC 200. The input 230 may be used to backup data stored in the components of the PCCC 200. Reference 232 in FIG. 2A shows a controller which may be used with the mobile communication device or in the absence of the mobile device to control the electronic components in the PCCC 200. For example, in the synching process when input 230 is operated the controller 232 would direct the synching operation.

[0043] FIG. 2B is a side view of the case 200 in a closed position. Data connection ports 224 and 226 provide communication capabilities to the case 200. Ports 224 and 226 may be a mini universal serial bus (USB), micro universal USB port or an audio visual (A/V) connector such as a high definition multimedia interface (HDMI) port and the like. Charging port 228 can be connected to the grid or other power source to feed the power source 212.

[0044] FIG. 3 is a second embodiment of the PCCC 200. Common numbering is used in FIGS. 3 through 9 and FIGS. 2A to 2B to denote similar elements. In this second embodiment, instead of wireless charging, a docking bay 305 having a set of electrical contacts is configured to electrically engage with the input/output contacts on a mobile communication device. The docking bay 305 may be a standard connector that allows the mobile communication device to receive power through line 307 from power source 217.

[0045] FIG. 4 illustrates a third embodiment of the PCCC 200. A mobile communication device 400 can be connected to a local area or wide area network through wireless modem 402 which may be 3G, 4G, 3G/4G, WHDMI, Bluetooth, WiFi, SuperWiFi, and other wireless standard. Module 404 is a replaceable, rechargeable battery that is charged through line 412 from the wireless charger 208 and receives power from mobile communication device 400. Module 404 performs the same function as power source 212 in FIG. 2 but is

arranged differently in the case 200 as shown in FIG. 4. The wireless charger 208 may be located on the first panel 202 beneath the mobile communications device 400. The module 404 can also be charged from a power outlet when the case 200 is plugged in. The module 404 can be used as a power source for other modules (reference numerals 408 and 410 as discussed below) located in the case 200. An embedded memory bank 406 includes a plurality of memory modules and is mounted on the second panel 204. The memory bank modules may be 500 MegaByte (MB), 1 Gigabyte (GB), 1 Terrabyte (TB) or the like in memory size. Memory slots 410 are capable of holding additional memory such as removable micro-Secure Digital (micro-SD) memory cards for storage expansion.

[0046] FIG. 5 illustrates a fourth embodiment of the PCCC 200 which demonstrates that the plurality of modules are detachable and could be two instead of three in the case 200. Also, FIG. 5 discloses a wireless data connection 512 between the device 400 and memory bank 406 using WiFi, SuperWiFi or Bluetooth protocols. In alternate embodiments, the data connection 512 could be a hardwired such as a Universal Serial Bus (USB), microUSB, miniUSB, or HDMI (with the data line being flexibly bendable across the flexible region 201 in the form of a ribbon cable or the like). In other embodiments, the connection could also be an optical wireless link or cable such as infrared. The data transfer could be bi-directional to allow for read and write both ways from device 400 to memory 406 and from memory 406 to device 400.

[0047] FIG. 6A is another embodiment of the PCCC with just one panel 500 attached to the device 400 through attachments 502. Attachments 502 may be magnets, clip ins, connectors or some other type of hinge. The attachments 502 may internally include a plurality of electrical links to provide power from the power source 212 to the mobile communication device 400 as well as provide data communications between the modules on the panel 500 and the device 400. The power source 212 may include a wireless charging unit so as to wirelessly charge the device 400. The charging may take place when the panel 500 is in a lateral position relative to the device 400 as shown in FIG. 6A. In an alternative embodiment, the panel 500 may be folded over and placed in contact with the device 500 to establish an electrical power link between the power source 212 and electrical contacts located on the device 400. Also, similar to the embodiment of FIG. 5, a wireless data connection may be established between the device 400 and the plurality of modules on the panel 500 (items 214, 216, 218, 220, and 222). FIG. 6B is a side view of the panel 500 showing the connection ports 224, 226, and 228 which serve the same functions as described in connection with FIG. 2B above.

[0048] FIG. 7 illustrates the mobile communication device 300 and PCCC 200 operating in a cloud (or networked) environment 700. Storage 706, mobile phone 708 and personal computer (PC) 710 are part of the cloud upon which the mobile communications device 300 and PCCC 200 can exchange data and synchronize through a plurality of wireless links 703. The WWAN modem module 214 and the WLAN modem module 216 of FIG. 7 operate in a similar manner as described in connection with FIG. 2A above. The mobile computing device 300 communicates through a bi-directional wireless link 701 with the WLAN modem 216 using Bluetooth, WiFi, SuperWiFi and similar wireless standards. In another embodiment, the link 701 may be a wired link.

WLAN modem **216** then can read and write wirelessly in a local environment with storage **706**. The WLAN modem **216** can also communicate with another mobile phone **708** and PC **710**. Alternatively, the mobile computing device **300** can communicate through WLAN **216** over a bi-directional link **702** with WWAN modem **214**. WWAN modem **214** can communicate wirelessly using 3G/4G protocols over longer distances than the WLAN modem **216** with a cell tower **704** and then to the Internet. In the environment of FIG. 7, the case **200** is acting as “hotspot”. As a hotspot, the case **200** offers network (e.g., Internet) access over the WWAN modem **214** or WLAN modem **216**.

[0049] FIG. 8 illustrates another variation of the mobile communication device **300** and the case **200** in operation **800**. This arrangement allows the local storage **218** to have access to a plurality of devices in the cloud such as the communication device **708**, PC **710** and storage **706** through local wireless router (or access point) **716**. As previously discussed in connection with FIG. 2A, sync input **230** can be operated when the mobile communication device is not present in the case **200** to backup all data contained in the components in the case **200** to the cloud (e.g., devices such as **706**, **708**, **710** and other devices). Another advantage is that this system allows for the formation of a “pass through Internet” from the mobile communication device **300** to devices **706**, **708**, **710** and a network (e.g., the Internet). WLAN modem **216** is connected to memory storage **218** through link **712** and is capable of establishing wireless communications with both the mobile communication device **300** and the devices **706**, **708**, and **710**. In operation, the mobile communication device **300** establishes a wireless connection **701** through WiFi, SuperWiFi, 4G or the like to the WLAN modem **216**. Through WLAN modem **216**, the communication device **300** is capable of connecting to the memory storage **218** (e.g., providing information or instructions regarding reading and/or writing) while simultaneously browsing the Internet through wireless link **703** to access point **716**. The term simultaneously as used herein shall mean immediate or nearly immediate succession in time. In another embodiment, the connection from the mobile communication device to the memory storage **218** could be wired. Alternatively, the communication device could be simultaneously connecting to memory storage **218** while communicating with devices **706**, **708** and **710** through wireless links **703**. This pass through Internet feature allows the user to access data stored in the memory **218** and browse the Internet simultaneously from a single device (mobile communication device **300**) or a plurality of devices. The WLAN modem **216** is designed to operate in one or more bands and cover one or more wireless standards. The bands may include first and second frequency bands (e.g., 2 GHz and 5 GHz). The WLAN modem **216** may use the first band for the transmission of information from memory storage **218** to the mobile communication device **300** and the second band for communications with the access point **716** (and thereby the Internet).

[0050] FIG. 9 illustrates another environment **900** in which the PCCC **200** may operate. The PCCC **200** allows the mobile communication device **300** to link through WLAN **216** and wireless link **902** with large external monitor **904** using WiFi, SuperWiFi, HDMI, or the like and display information (e.g., video, audio, or text) from either the mobile communication device **300**, the memory storage or another source (e.g., devices **706**, **708**, **710**) on to the monitor **904**.

[0051] FIG. 10 is a front view of another embodiment **1000** of the PCCC which is shown in an open position. As previously discussed, the mobile computing device **1002** in the case **1000** could be an iPad®, iPhone®, PC tablet, Android® based tablet, TouchPad, Nexus 7®, Slate® or the like. Embodiment **1000** and embodiments **1100**, **1200**, **1300**, **1400**, **1700**, **1800**, **1900**, **2000**, **2100**, **2200**, and **2300** discussed below operate in a manner similar to the other embodiments of the PCCC disclosed above in the discussions of FIGS. 2A through 9. In embodiment **1000**, however, the mobile computing device **1002** is mounted on the right (or second) panel **1000b** of the case cover. Embodiment **1000** may provide a personal cloud to the user and access to wireless networks (such as 3G, 4G, WiFi, SuperWiFi, and similar wireless technologies). The right panel **1000b** includes the electronic components, modules (including WLAN and WWAN wireless modules), memory and power source as described above with regard to second panel **204** in FIG. 2A. However, it is also included the wireless charging module **208** which is shown FIG. 2A mounted on the first panel **202**. So panel **1000b** includes the components of both **202** and **204** of FIG. 2A. In this embodiment **1000**, the left (or first) panel **1000a** of the case cover has a window **1000c** which allows for a view of either all or part of the screen of the mobile device **1002** when the case is closed. For example, the window **1000c** might be approximately one quarter to approximately one half the surface area of the left panel **1000a**. The case **1000** also has an attachment **1004** for a stylus **1004a** such as a pressure sensitive pen.

[0052] FIG. 11 illustrates an embodiment **1100** of the PCCC which has an embedded (or mounted) screen **1100c** on the left (or first) panel cover **1100a**. The mobile computing device **1002** is mounted on the right (or second) panel **1100b**. Embodiment **1100** may provide a personal cloud to the user and access to wireless networks (such as 3G, 4G, WiFi, SuperWiFi, and similar wireless technologies). The right panel **1100b** includes the electronic components, modules (including WLAN and WWAN wireless modules), memory and power source as described above with regard to second panel **204** in FIG. 2A. However, it is also may include the wireless charging module **208** which is shown FIG. 2A mounted on the first panel **202**. In alternative embodiments, the wireless charging module **208** can be embedded in the left panel **1100a** and provide power to the screen **1100c** as shown in FIG. 2A mounted on the first panel **202**. The screen of the mobile computing device **1002** and the screen **1100c** each may be an organic light emitting diode (OLED), light emitting diode (LED), liquid crystal display (LCD), Mirasol®, E Ink or the like. The screen **1100c** could have an embedded digitizer for drawing, writing and taking notes and be pen input sensitive. The embodiment **1100** has a holder (or attachment) **1102** for an input pen **1102a**.

[0053] FIG. 12 illustrates an embodiment **1200** of the PCCC which has a screen **1200c** (which may be embedded) mounted on the outside of the left panel cover **1200a** with the mobile device **1002** located in the right panel **1200b**. FIG. 13 shows a similar embodiment **1300** of the PCCC with an embedded screen **1300c** also mounted on the outside of the left panel **1300a** with the mobile device **1002** mounted on the right panel **1300b**. However in this embodiment, the screen **1300c** covers approximately twenty-five percent to approximately half the surface of the left panel **1300a**. The right panels **1200b** and **1300b** includes the electronic components, modules (including WLAN and WWAN wireless modules),

memory and power source as described above with regard to second panel 204 in FIG. 2A. However, the panels 1200b and 1300b may also include the wireless charging module 208 which is shown in FIG. 2A mounted on the first panel 202. In an alternative embodiment, the wireless charging module 208 can be embedded in the left panels 1200a and 1300a and provide power to the screens 1200c and 1300c as shown in FIG. 2A with regard to first panel 202. The screen of the mobile computing device 1002 and the screens 1200c and 1300c each may be an OLED, LED, LCD, Mirasol®, E Ink or the like. The screen 1200c and 1300c could have an embedded digitizer for drawing, writing and taking notes and be pen input sensitive.

[0054] FIG. 14 is a view of another embodiment 1400 of the PCCC. Embodiment 1400 operates in a manner similar to the other embodiments of the PCCC disclosed above in the discussions of FIGS. 2A-13 but instead the electronic components are mounted on a structure such as a band instead of a case. Embodiment 1400 provides a personal cloud to the user and access to wireless networks (such as 3G, 4G, WiFi, SuperWiFi, and similar wireless technologies). The structure 1400 may be a watch-type band made of waterproof material and manufactured by injection molding. Electronics components in the band such as controllers, memory modules, batteries, and the like may be entirely covered by the structural material. In alternative embodiments the structure 1400 may be made of any material (hard and/or soft) that makes the embodiment 1400 lightweight but durable and resilient such as plastic, silicone, ceramic, fabric, leather, steel, aluminum, fiberglass, titanium, Kevlar, and/or rubber. The surface of the structure itself may be touch sensitive 1402 to communicate with a mobile device located on the band in cavity 1406 or nearby. The band may be substantially circular or substantially oblong in shape and be capable of being wrapped around the hand, wrist, forearm, bicep, head, or leg of the wearer or around the wearers' clothing such as a hat (or helmet). The band should have some type of clasp device (e.g. Velcro, metal clasp, etc.) mounted on each of the ends of the band for attachment. A cavity 1406 is located in the band and, typically, in the central portion of the band. Wireless charging circuitry 1404 may be in electrical connection with cavity 1406 and may extend out from both sides of cavity 1406. The wireless charging circuitry can provide both power and serve as a data link. For example, the wireless charging circuitry 1404 may be connected to the touch sensitive surface 1402 to communicate data to the mobile device in the cavity 1406. The wireless charging circuitry 1404 may be ribbon cable so that it flexibly bends with the band. Wireless charging circuitry 1404 may be internal to the band and extend along substantially the length of the band. The wireless charging circuitry 1404 may be connected to electronic modules and components mounted on the band such as modules 1410 and 1412 and memory bank module 1411 (which may be made up of a plurality of memory modules). The wireless charging circuitry 1404 is configured to transfer power from at least one, several or all of the of the modules to a mobile computing device mounted in the cavity 1406 or may transfer power from the mobile computing device in the cavity to at least one, several or all of the modules 1410, 1411, and 1412. Similar to synchronization button 230, the band may also have an input (such as the touch sensitive screen 1404) configured to direct the plurality of electronic components to receive synchronization information from a wireless network.

[0055] Cavity 1406 contains antenna 1407 which may be mounted on a miniature wireless charging unit 1408 or mounted separately. Wireless charging unit 1408 is connected to wireless charging circuitry 1404 and may operate by magnetic resonance, inductive charging, or power over RF or similar wireless charging methods to charge an a mobile communication device mounted in the cavity 1406. Along with the wireless charging unit 1408 there may be a battery 1409 located in the cavity and in connection with the wireless charging unit 1408 and the wireless charging circuitry 1404. Reference numerals 1414 and 1416 indicate data ports providing outside connections to cavity 1406. Data ports 1414 and 1416 may be microUSB, HDMI, NV inputs or the like and are linked to both the mobile communication device in the cavity 1406 and over wireless charging circuitry 1404 to the modules 1410a, 1410b, 1411, and 1412. Port 1418 may be a charging port to provide power to the wireless charging unit 1408 and/or battery 1409 located in the cavity 1406 and ultimately to the mobile communication device and the electronic components in the band. Electrically connected to the cavity 1406 is a wireless modules 1410a and 1410b. Wireless module 1410a may be a WWAN modem to link the electronic device to 3G, 4G or other future network. Wireless module 1410b may be a WLAN modem to link the electronic device using WiFi, SuperWiFi, Bluetooth, WHDMI, or the like. Functionally modules 1410a and 1410b operate similarly to modules 214 and 216 as described above. Memory bank 1411 (similar to memory bank 218) may include a plurality of replaceable memory modules having internal storage such as SSD, flash memory, or the like. Since the memory bank 1411 (and its memory modules) are coupled (or in communication) with the wireless modems 1410a and 1410b, the band is therefore configured to allow for simultaneous connection of the mobile communication device with the memory bank 1411 and through the wireless modem to a network. Module 1412 (similar to module 220) may be a sensory module and may contain a sensor chip which can detect biometric inputs such as finger prints, eye movement, face shape and the like.

[0056] FIG. 15 shows detachably mounted on the structure 1400 a mobile wireless computing device 1420 which functions like (and may actually be) an iPad®, iPhone®, PC tablet, Android® based tablet, TouchPad, Nexus 7®, Slate® or the like. Cavity 1406 may be designed to allow the mobile computing device 1420 to be snapped into position in the cavity 1406. The form factor of the mobile computing device 1420 can be the typical size of these devices and be mounted substantially lengthwise with the band or substantially perpendicular to the direction of the band. The form factor of the computing device 1420 can also be approximately the size of a watch or a watch phone having a rectangular or square shape with outside dimensions such as: length in the range of 22 mm to 44 mm; width in the range of 22 mm to 44 mm; and height (or thickness) in the range of 4 mm to 18 mm. The screen sizes of these computing devices can also be rectangular or square and be in the ranges such as: length 18 mm to 42 mm; width in the range of 18 mm to 42 mm; and height (or thickness) in range of 2 mm to 4 mm. In the case of substantially circular profiles the dimensions may be: diameter in the range of 22 to 44 mm and height (or thickness) in the range of 4 mm to 18 mm with substantially circular screens having dimensions of: 18 mm to 42 mm and height (or thickness) 2 mm to 4 mm. Further, the mobile computing device 1420 can be flexible. The device 1420 can be mounted in or on top of the cavity 1406 using a mechanical attachment (e.g., snap-in) or a mag-

netic coupling. In addition, as shown in FIG. 15, the modules 1410a, 1410b, 1411, and 1012 may be integrated into the structure of the band and therefore not visible from the outside of the band.

[0057] FIG. 16 illustrates the embodiment 1400 operating in a cloud environment 1600. The embodiment 1400 allows mobile communication device 1420 to communicate with an external device 1620. The mobile computing device 1420 can connect directly through a wireless link 1610 or a wired connection (not shown). The mobile computing device 1420 can also link through the wireless modules 1410a and 1410b (e.g., a WLAN module, a WWAN module) and the wireless link 1610 to the external device 1620. The wireless link 1610 may be made using WiFi, SuperWiFi, WHDMI, Bluetooth, NFC type protocols, 3G/4G, or the like. The external device 1620 can be almost any type of display device such as an iPad®, iPhone®, PC tablet, Android® based tablet, Touch-Pad, Nexus 7®, Slate®, smart TV, display for a projection device or the like. The band system described herein allows a user of the band to easily display information stored in the memory bank 1411 on the band to an external device 1620. Therefore, the operator of the band does not have to carry around a large display but rather can mate (usually wirelessly) with almost any type of much larger display to share information stored in the memory banks of the band including text, audio and video materials. In alternative embodiments, the computing device may not have a screen at all and the band may be designed to provide the functionalities of a mobile computing device but without a display screen at all. The band (whether there is a mobile computing device mounted therein or not) is configured to mate with whichever display is readily available. Embodiments 1100, 1200, 1300, 1700, 1800, 1900, 2000, 2100, 2200, and 2300 discussed herein are also configured to mate with an external device.

[0058] FIG. 17 illustrates an embodiment 1700 of the PCCC which has a screen 1700b mounted on a structure such as band 1700a. Examples of the band 1700a include a bracelet or sweatband. The screen 1700b may be flexible and cover less than the entire band in a range approximately 25% to 50% of the band or 50% to 75% of the band. The screen 1700b may be an OLED, LED, LCD, Mirasol®, E Ink or the like. In alternative embodiments, the screen 1700b may include an embedded digitizer for drawing, writing and taking notes and be pen input sensitive. Embodiment 1700 provides a personal cloud to the user and access to wireless networks (such as 3G, 4G, WiFi, SuperWiFi, and similar wireless technologies). The structure 1700 may be a band 1700a made of waterproof material and manufactured by injection molding. Electronics components in the band such as controllers, memory modules, batteries, and the like may be entirely covered by the structural material. The band 1700a may include the electronic components, modules (including WLAN and WWAN wireless modules), memory and power source as described above with regard to second panel 204 in FIG. 2A. However, it is also may include the wireless charging module 208 which is shown FIG. 2A mounted on the first panel 202. In alternative embodiments the structure 1700 may be made of any material (hard and/or soft) that makes the embodiment 1700 lightweight but durable and resilient such as plastic, silicone, ceramic, fabric, leather, steel, aluminum, fiberglass, titanium, Kevlar, and/or rubber. The band 1700a may be substantially circular or substantially oblong in shape and be capable of being wrapped around the hand, wrist, forearm, bicep, head, or leg of the wearer or around the wearers' clothing such as a

hat (or helmet). The band may have some type of clasping device (e.g. Velcro, metal clasp, etc.) mounted on each of the ends of the band for attachment. Wireless charging circuitry may extend out from both sides of screen 1700b. The wireless charging circuitry can provide both power and serve as a data link. The wireless charging circuitry may be ribbon cable so that it flexibly bends with the band. Wireless charging circuitry may be internal to the band 1700a and extend along substantially the length of the band. The wireless charging circuitry may be wireless and have memory modules. The wireless charging circuitry may be configured to transfer power from at least one, several or all of the modules to screen 1700b (or an attached mobile computing device) or may transfer power from the screen 1700b (or an attached mobile computing device) to at least one, several or all of the modules. Similar to synchronization button 230, the band may also have an input configured to direct the plurality of electronic components to receive synchronization information from a wireless network. The band 1700a may contain an antenna. A wireless charging unit may be connected to the wireless charging circuitry and may operate by magnetic resonance, inductive charging, or power over RF or similar wireless charging methods to charge the screen 1700b or a nearby mobile computing device. Along with the wireless charging unit there may be a battery located in the band 1700a and in connection with the wireless charging unit and the wireless charging circuitry. The band 1700a may include data ports providing outside connections to the band 1700a and screen 1700b. The data ports may be microUSB, HDMI, A/V inputs or the like and are linked to both the screen 1700b and over wireless charging circuitry to the modules. One port may be a charging port to provide power to the wireless charging unit and/or a battery and ultimately to the screen 1700b and the electronic components in the band 1700a. Electrically connected to the screen 1700b may be a plurality of wireless modules. One wireless module may be a WWAN modem to link the electronic device to 3G, 4G or other future network. Alternatively or additionally, another wireless module may be a WLAN modem to link the electronic device using WiFi, SuperWiFi, Bluetooth, WHDMI, or the like. Functionally these wireless modules will operate similarly to modules 214 and 216 as described above. A memory bank (similar to memory bank 218) may include a plurality of replaceable memory modules having internal storage such as SSD, flash memory, or the like. Since the memory bank (and its memory modules) may be in communication with the wireless modems, the band is therefore configured to allow for simultaneous connection of the mobile communication device with the memory bank and through the wireless modem to an external network. There may also be a module (similar to module 220) that may be sensory module and may contain a sensor chip which can detect biometric inputs such as finger prints, eye movement, face shape and the like.

[0059] FIGS. 18A and 18B illustrate an embodiment 1800 of the PCCC which has a wallet structure which is similar in structure (albeit smaller) to the case 200 as shown in FIG. 2A with a first wallet panel 1800a and a second wallet panel 1800b. As shown in FIG. 18A, screen 1800c may be embedded or mounted on the outside of the first wallet panel 1800. The screen 1800c may be flexible and cover in a range between either approximately half the entire surface or the approximately the entire surface of first wallet panel 1800a. The screen 1800c may be an OLED, LED, LCD, Mirasol®, E Ink or the like. The screen 1800c could have an embedded

digitizer for drawing, writing and taking notes and be pen input sensitive. FIG. 18B shows the wallet 1800 in an open position. As discussed with regard to previous embodiments above, wallet 1800 provides a personal cloud to the user and access to wireless networks (such as 3G, 4G, WiFi, SuperWiFi, and similar wireless technologies). The wallet 1800 may include the electronic components, modules (including WLAN and WWAN wireless modules), memory and power source as described above with regard to second panel 204 in FIG. 2A. However, it is also may include the wireless charging module 208 which is shown FIG. 2A mounted on the first panel 202. Electronics components in the wallet 1800 such as controllers, memory modules, batteries, and the like may be entirely covered by the structural material. The structure 1800 may be made of leather and/or waterproof material. In alternative embodiments the structure 1800 may be made of any material (hard and/or soft) that makes the embodiment 1800 lightweight but durable and resilient such as plastic, silicone, ceramic, fabric, leather, steel, aluminum, fiberglass, titanium, Kevlar, and/or rubber. The wallet 1800 may be approximately rectangular in shape. Wireless charging circuitry may extend out from the screen 1800c. The wireless charging circuitry can provide both power and serve as a data link. The wireless charging circuitry may be ribbon cable so that it flexibly bends with the wallet. Wireless charging circuitry may be internal to the wallet and extend along substantially the length of the wallet in both the first panel 1800a and the second panel 1800b. The wireless charging circuitry may operate wirelessly and have a plurality of modules. The wireless charging circuitry may be configured to transfer power from at least one, several or all of the of the modules to screen 1800c or may transfer power from the screen 1800c to at least one, several or all of the modules. The wireless charging circuitry may also attach (e.g., through a USB port) to a mobile computing device to provide power to or receive power from the mobile computing device. Similar to synchronization button 230, the wallet 1800 may also have an input configured to direct the plurality of electronic components to receive synchronization information from a wireless network. The wallet 1800 may further contain an antenna. A wireless charging unit may be connected to wireless charging circuitry and may operate by magnetic resonance, inductive charging, or power over RF or similar wireless charging methods to charge the screen 1800c or provide power to or receive power from a nearby mobile computing device and/or modules (e.g., power modules) in the wallet 1800. Along with the wireless charging unit there may be a battery located in the wallet 1800 and in connection with the wireless charging unit and the wireless charging circuitry. The wallet 1800 may include data ports providing outside connections to the wallet 1800 and screen 1800c. The data ports may be microUSB, HDMI, A/V inputs or the like and are linked to both the screen 1800c and over wireless charging circuitry to the modules. One port may be a charging port to provide power to the wireless charging unit, a battery, screen 1800c, the electronic components in the wallet 1800 and/or an attached (or detached) mobile computing device. Electrically connected to the screen 1800c may be wireless modules. One wireless module may be a WWAN modem to link the electronic device to 3G, 4G or other future network. Alternatively or additionally, another wireless module may be a WLAN modem to link the electronic device using WiFi, SuperWiFi, Bluetooth, WHDMI, or the like. Functionally these wireless modules will operate similarly to modules 214 and 216 as described above. A memory bank

(similar to memory bank 218) may include a plurality of replaceable memory modules having internal storage such as SSD, flash memory, or the like. Since the memory bank (and its memory modules) may be communication with the wireless modems, the wallet 1800 is therefore configured to allow for simultaneous connection of the mobile communication device with the memory bank and through the wireless modem to a network. There may also be a module (similar to module 220) which may be a sensory module and may contain a sensor chip which can detect biometric inputs such as finger prints, eye movement, face shape and the like.

[0060] FIGS. 19A and 19B illustrate an embodiment 1900 of the PCCC which also has a wallet structure with a first wallet panel 1900a and a second wallet panel 1900b. Embodiment 1900 is constructed and functions in the same manner as embodiment 1800 except for the absence of a screen.

[0061] FIGS. 20A and 20B illustrate an embodiment 2000 of the PCCC which has a collar structure with a first collar panel 2000a and a second collar panel 2000b. As discussed with regard to previous embodiments above, collar 2000 provides a personal cloud to the user and access to wireless networks (such as 3G, 4G, WiFi, SuperWiFi, and similar wireless technologies). The structure 2000 may be made of cloth and/or waterproof material. The collar 2000 may include the electronic components, modules (including WLAN and WWAN wireless modules), memory and power source as described above with regard to second panel 204 in FIG. 2A. However, it is also may include the wireless charging module 208 which is shown FIG. 2A mounted on the first panel 202. Electronics components in the collar 2000 such as controllers, memory modules, batteries, and the like may be entirely covered by the structural material. In alternative embodiments the structure 2000 may be made of any material (hard and/or soft) that makes the embodiment 2000 lightweight but durable and resilient such as plastic, silicone, ceramic, fabric, leather, steel, aluminum, fiberglass, titanium, Kevlar, and/or rubber. The collar 2000 may be rectangular or trapezoidal in shape. Wireless charging circuitry may extend throughout the first collar panel 2000a and second collar panel 2000b. The wireless charging circuitry can provide both power and serve as a data link. The wireless charging circuitry may be ribbon cable so that it flexibly bends with the collar. Wireless charging circuitry may be internal to the collar and extend along substantially the length of the collar in both the first panel 2000a and the second panel 2000b and electrically connect the two panels. The wireless charging circuitry may be wireless and have a plurality of modules. The wireless charging circuitry may be configured to transfer power from at least one, several or all of the of the modules. A mobile wireless device may be configured to attach to the collar 2000 and receive power from or provide power to the wireless charging circuitry. Similar to synchronization button 230, the collar 2000 may also have an input configured to direct the plurality of electronic components to receive synchronization information from a wireless network. The collar 2000 may further contain an antenna. A wireless charging unit may be connected to wireless charging circuitry and may operate by magnetic resonance, inductive charging, or power over RF or similar wireless charging methods to provide power to or receive power from a mobile computing device and/or the modules (e.g., power modules) in the collar 2000. Along with the wireless charging unit there may be a battery located in the collar 2000 and in connection with the wireless charging unit and the wireless charging circuitry. The collar 2000 may

include data ports providing outside connections to the collar **2000**. The data ports may be microUSB, HDMI, A/V inputs or the like and are linked wireless charging circuitry to the modules. One port may be a charging port to provide power to the wireless charging unit, a battery, the electronic components in the collar **2000** and/or an attached (or nearby detached) mobile computing device. The collar **2000** may include a wireless module which may be a WWAN modem to link the electronic device to 3G, 4G or other future network. Alternatively or additionally, another wireless module may be a WLAN modem to link the electronic device using WiFi, SuperWiFi, Bluetooth, WHDMI, or the like. Functionally these wireless modules will operate similarly to modules **214** and **216** as described above. A memory bank (similar to memory bank **218**) may include a plurality of replaceable memory modules having internal storage such as SSD, flash memory, or the like. Since the memory bank (and its memory modules) may be communication with the wireless modems, the band is therefore configured to allow for simultaneous connection of the mobile communication device with the memory bank and through the wireless modem to a network. There may also be a module (similar to module **220**) may be sensory module and may contain a sensor chip which can detect biometric inputs such as finger prints, eye movement, face shape and the like.

[0062] FIG. **21** illustrates an embodiment **2100** of the PCCC which has a key chain (or fob) shape with a key chain panel **2100a**. As discussed with regard to previous embodiments above, key chain **2100** provides a personal cloud to the user and access to wireless networks (such as 3G, 4G, WiFi, SuperWiFi, and similar wireless technologies). The structure **2100** may include the electronic components, modules (including WLAN and WWAN wireless modules), memory and power source as described above with regard to second panel **204** in FIG. **2A**. However, it is also may include the wireless charging module **208** which is shown FIG. **2A** mounted on the first panel **202**. Electronics components in the band such as controllers, memory modules, batteries, and the like may be entirely covered by the structural material. The structure **2100** may be made of waterproof material. In alternative embodiments the structure **2100** may be made of any material (hard and/or soft) that makes the embodiment **2100** lightweight but durable and resilient such as plastic, silicone, ceramic, fabric, leather, steel, aluminum, fiberglass, titanium, Kevlar, and/or rubber. The key chain **2100** may be substantially rectangular, substantially cubic or substantially circular in shape. Wireless charging circuitry may extend throughout the key chain panel **2100a**. The wireless charging circuitry can provide both power and serve as a data link. The wireless charging circuitry may be a ribbon cable. Wireless charging circuitry may be internal to the key chain **2100** and extend along substantially the length of the key chain panel **2100a**. The wireless charging circuitry may be wireless and have a plurality of modules. The wireless charging circuitry may be configured to transfer power from at least one, several or all of the modules. A mobile wireless device may be configured to attach to the key chain panel **2100a** and receive from or provide power to the wireless charging circuitry. Similar to synchronization button **230**, the key chain **2100** may also have an input configured to direct the plurality of electronic components to receive synchronization information from a wireless network. The key chain **2100** may further include an antenna. A wireless charging unit may be connected to wireless charging circuitry and may operate by magnetic resonance, inductive charging, or

power over RF or similar wireless charging methods to provide power to or receive power from a nearby mobile device and/or modules (e.g., power modules) in the key chain **2100**. Along with the wireless charging unit there may be a battery located in the key chain **2100** and in connection with the wireless charging unit and the wireless charging circuitry. The key chain may include data ports providing outside connections to the key chain **2100**. The data ports may be microUSB, HDMI, NV inputs or the like and are linked wireless charging circuitry to the modules. One port may be a charging port to provide power to the wireless charging unit, a battery, the electronic components in the key chain **2100** and/or an attached (or nearby non-attached) mobile device. The key chain **2100** may include a wireless module which may be a WWAN modem to link the electronic device to 3G, 4G or other future network. Alternatively or additionally, another wireless module may be a WLAN modem to link the electronic device using WiFi, SuperWiFi, Bluetooth, WHDMI, or the like. Functionally these wireless modules will operate similarly to modules **214** and **216** as described above. A memory bank (similar to memory bank **218**) may include a plurality of replaceable memory modules having internal storage such as SSD, flash memory, or the like. Since the memory bank (and its memory modules) may be communication with the wireless modems, the band is therefore configured to allow for simultaneous connection of the mobile computing device with the memory bank and through the wireless modem to a network. There may also be a module (similar to module **220**) may be sensory module and may contain a sensor chip which can detect biometric inputs such as finger prints, eye movement, face shape and the like.

[0063] FIG. **22** illustrates an embodiment **2200** of the PCCC which has a tie shape structure with a tie panel **2200a**. As discussed with regard to previous embodiments above, tie **2200** provides a personal cloud to the user and access to wireless networks (such as 3G, 4G, WiFi, SuperWiFi, and similar wireless technologies). The structure **2200** may include the electronic components, modules (including WLAN and WWAN wireless modules), memory and power source as described above with regard to second panel **204** in FIG. **2A**. However, it is also may include the wireless charging module **208** which is shown FIG. **2A** mounted on the first panel **202**. Electronics components in the tie such as controllers, memory modules, batteries, and the like may be entirely covered by the structural material. The structure **2200** may be made of clothe and/or waterproof material. In alternative embodiments the structure **2200** may be made of any material (hard and/or soft) that makes the embodiment **2200** lightweight but durable and resilient such as plastic, silicone, ceramic, fabric, leather, steel, aluminum, fiberglass, titanium, Kevlar, and/or rubber. Wireless charging circuitry may extend throughout the tie panel **2200a**. The wireless charging circuitry can provide both power and serve as a data link. The wireless charging circuitry may be a flexible, ribbon cable. Wireless charging circuitry may be internal to the tie **2200** and extend along substantially the length of the tie panel **2200a**. The wireless charging circuitry may be wireless and have a plurality of modules. The wireless charging circuitry may be configured to transfer power from at least one, several or all of the of the modules or an attached (e.g. by USB) mobile computing device. Similar to synchronization button **230**, the tie **2200** may also have an input configured to direct the plurality of electronic components to receive synchronization information from a wireless network. The tie **2200** may fur-

ther contain an antenna. Wireless charging unit may be connected to wireless charging circuitry and may operate by magnetic resonance, inductive charging, or power over RF or similar wireless charging methods to provide power to or receive power from a nearby mobile computing device and/or modules (e.g., power modules) in the tie **2200**. Along with the wireless charging unit there may be a battery located in the tie **2200** and in connection with the wireless charging unit and the wireless charging circuitry. The tie **2200** may include data ports providing outside connections to the tie **2200**. The data ports may be microUSB, HDMI, A/V inputs or the like and are linked wireless charging circuitry to the modules. One port may be a charging port to provide power to the wireless charging unit, a battery, the electronic components in the tie **2200** and/or an attached mobile computing device. The tie **2200** may include a wireless module which may be a WWAN modem to link the electronic device to 3G, 4G or other future network. Alternatively or additionally, another wireless module may be a WLAN modem to link the electronic device using WiFi, SuperWiFi, Bluetooth, WHDMI, or the like. Functionally these wireless modules will operate similarly to modules **214** and **216** as described above. A memory bank (similar to memory bank **218**) may include a plurality of replaceable memory modules having internal storage such as SSD, flash memory, or the like. Since the memory bank (and its memory modules) may be in communication with the wireless modems, the tie is therefore configured to allow for simultaneous connection of the mobile communication device with the memory bank and through the wireless modem to a network. There may also be a module (similar to module **220**) which may be sensory module and may contain a sensor chip which can detect biometric inputs such as finger prints, eye movement, face shape and the like.

[0064] FIG. **23** illustrates an embodiment **2300** of the PCCC which has a belt shape structure with a belt panel **2300a**. As discussed with regard to previous embodiments above, belt **2300** provides a personal cloud to the user and access to wireless networks (such as 3G, 4G, WiFi, SuperWiFi, and similar wireless technologies). The structure **2300** may include the electronic components, modules (including WLAN and WWAN wireless modules), memory and power source as described above with regard to second panel **204** in FIG. **2A**. However, it also may include the wireless charging module **208** which is shown FIG. **2A** mounted on the first panel **202**. Electronics components in the belt **2300** such as controllers, memory modules, batteries, and the like may be entirely covered by the structural material. The structure **2300** may be made of cloth, leather and/or waterproof material. In alternative embodiments the structure **2300** may be made of any material (hard and/or soft) that makes the embodiment **2300** lightweight but durable and resilient such as plastic, silicone, ceramic, fabric, leather, steel, aluminum, fiberglass, titanium, Kevlar, and/or rubber. The belt **2300** may be rectangular in shape. Wireless charging circuitry may extend throughout the belt panel **2300a**. The wireless charging circuitry can provide both power and serve as a data link. The wireless charging circuitry may be a flexible, ribbon cable. Wireless charging circuitry may be internal to the belt **2300** and extend along substantially the length of the belt panel **2300a**. The wireless charging circuitry may be wireless and have a plurality of modules. The wireless charging circuitry may be configured to transfer power from at least one, several or all of the of the modules or to an attached (or detached) mobile computing device. Similar to synchronization button

230, the belt **2300** may also have an input configured to direct the plurality of electronic components to receive synchronization information from a wireless network. The belt **2300** may further contain an antenna. A wireless charging unit may be connected to the wireless charging circuitry and may operate by magnetic resonance, inductive charging, or power over RF or similar wireless charging methods to provide power to or receive power from a nearby mobile computing device and/or modules (e.g., power modules) on the belt **2300**. Along with the wireless charging unit there may be a battery located in the belt **2300** and in connection with the wireless charging unit and the wireless charging circuitry. The belt **2300** may include data ports providing outside connections to the belt **2300**. The data ports may be microUSB, HDMI, NV inputs or the like and are linked wireless charging circuitry to the modules. One port may be a charging port to provide power to the wireless charging unit, a battery, the electronic components in the belt **2300** and/or an attached mobile computing device. The belt **2300** may include a wireless module which may be a WWAN modem to link the electronic device to 3G, 4G or other future network. Alternatively or additionally, another wireless module may be a WLAN modem to link the electronic device using WiFi, SuperWiFi, Bluetooth, WHDMI, or the like. Functionally these wireless modules will operate similarly to modules **214** and **216** as described above. A memory bank (similar to memory bank **218**) may include a plurality of replaceable memory modules having internal storage such as SSD, flash memory, or the like. Since the memory bank (and its memory modules) may be in communication with the wireless modems, the band is therefore configured to allow for simultaneous connection of the mobile communication device with the memory bank and through the wireless modem to a network. There may also be a module (similar to module **220**) which may be sensory module and may contain a sensor chip which can detect biometric inputs such as finger prints, eye movement, face shape and the like.

[0065] FIG. **24** illustrates another embodiment of the PCCC which is a medical/health case cover **2400** made up of components to monitor human health. When it comes to monitoring human health, today's consumers are limited to so-called "health trackers" which count steps and calculate calorie burns. Traditional health trackers are only capable of measuring heart rate and are limited to external measurements. These devices are not capable of getting the internal body data; meaning they do not have access to human fluids. The personal cloud case cover gives users a health monitoring lab, with integrated biochips, microarray and other chip size medical analyzers. The health cover can not only analyze human fluids but also fluids being consumed by the user (food and drinks). The data collected from the fluids is then compared to a cloud or local data base. The results are displayed on a phone, tablet, PC, TV, or any other device connected to the health cover. Today people have to visit their doctors in order to perform fluid tests and get information about their health. The health cover can easily share the data with one's doctor over a secure network without a doctors visit. For example, doctors can ask their patients to submit blood samples through the personal health shield.

[0066] The medical/health case cover **2400** is a case with modular capabilities made of materials such as leather and/or plastic. It contains bio/mechanical/electrical components in one or two panels, meaning the case can have two panels/sides or only one side/panel. Modem **2402** may be WiFi, 3G,

4G, and 5G. To access highly secure health network that contains health database and access to thousands of medical professionals. Doctors can easily interact with the patient and compete for their business. Camera **2404** can analyze a human eye and share information with your doctor. Needles **2406** may be used to help draw blood. The needles are easily removable/swappable. Biochip module **2408** uses light to analyze liquids received through liquid input **2410**. The liquids may be blood, drinks or any other type of liquid requiring analysis. Biochip module **2412** uses radio frequency (RF) to analyze inputs received through liquid input **2414**. Microarray module **2416** analyzes inputs received through liquid input **2418**. Internal database **2420** contains a database of the most common diseases and can be customized to a persons health. The database can be constantly updated. Also, shows the closest clinics and compares the costs and insurance coverage. Power source **2422** is used to power the case cover. Electrocardiogram (EKG) **2424** is capable of measuring problems with the electrical activity of the heart.

[0067] FIG. 25 shows the medical/health case cover **2400** operating in a cloud (or networked) environment. The modem **2402** establishes a bi-directional 3G/4G/5G secure network connection **2502** between the case cover **2400** and a cell tower **2504** to share data collected and/or analyzed at the case **2400** with a medical professional wireless device and/or health database **2508**. In this example, the case cover is acting as a “hotspot” to provide network access for locally collected medical/health data. In another embodiment, link **2502** may be a wired connection.

[0068] FIG. 26 illustrates an environmental sensor (or wearable environmental sensor or universal sensor) embodiment **2600** capable of detecting environmental conditions and relaying the information to the user. FIG. 27 is a circuit diagram of the underlying electronic components of the environmental sensor **2600** contained in a housing **2602**. The housing may be circular, square, or rectangular in shape or the like. The housing may broadly have a user interface system including a touch sensitive visual display screen **2604**. In addition to inputting through the touch sensitive visual display **2604**, the operator may input through buttons or actuators mounted on the sides of the housing surrounding the visual display (e.g., button **2606**). The housing typically includes a processor **2608** which is communicatively coupled with the touch sensitive visual display screen **2604**, a memory **2610** having a database **2612**, a wireless communication system **2614**, an input/output (I/O) module **2616** and a power source (e.g., battery) **2618**. In a first time function, the processor **2608** will keep track of the time and display it in analog or digital form on the visual display screen **2604**. The other functions of the environmental sensor **2600** may be performed over the background surface of the time or some other background selection stored in memory **2610**. Exemplary housings **2602** may include a system bus **2620** and/or one or more interface circuits (not shown) for coupling the processor **2608** and other components (e.g., visual display **2604**, memory **2610**, wireless communication system **2614**, I/O module **2616** and a plurality of sensors discussed below) to the system bus **2618** and to each other.

[0069] Typically, the processor **2608** is configured to execute instructions and to carry out operations associated with the environmental sensor **2600**. For example, using instructions retrieved from the memory **2610** (e.g., a memory block), the processor **2608** may control the reception and manipulation of input and output data between components

of the housing **2602**. The processor **2608** is configured for capturing data from the plurality of sensors in the housing **2602**, operate with an operating system to execute computer code to process the data and display the data on the visual display **2604**. The operating system, other computer code, and data may reside within the memory **2610** that is operatively coupled to the processor **2608**. The memory **2610** generally provides a place to store computer code and data that are used by the environmental sensor **2600**. The memory **2610** may include Read-Only Memory (ROM), Random-Access Memory (RAM), and/or other non-transitory storage media. The operating system, other computer code, and data may also reside on a removable non-transitory storage medium that is loaded or installed onto the environmental sensor **2600** when needed. The wireless communication system **2614** may have a modem or a plurality of modems that enable the environmental sensor **2600** to communicate with a wireless network, such as a cellular network (e.g., a GSM network, a CDMA network, or an LTE network), a local area network (LAN), and/or an ad hoc network. The environmental sensor **2600** may further have a modem in the wireless communication system capable of communicating using Bluetooth™, WiFi, WiFi Direct, or other wireless communication technology with a phone or hotspot and then to a phone base station. In some embodiments, the wireless communication system **2614** also allows the environmental sensor to communicate with a corresponding wireless communication system in another universal sensor. The wireless communication system **2614** may have a first low power transmitter or low power transmit mode which can last for extended time periods (e.g., several months) with little draw on the battery and without charging. In addition, the wireless communication system may have a second high power transmitter or high power transmit mode which draws much more power from the battery and may typically be used in case of emergency when the base station is distant. The I/O module **2616** may be a hardwire connector which allows the environmental sensor **2600** to receive power and/or data when plugged in.

[0070] The environmental sensor **2600** may be worn on the body and its housing **2602** attached by a band **2622** to a body part such as wrist, leg, neck, or the like. The environmental sensor **2600** includes a plurality of different types of sensors to obtain a picture of either the surrounding conditions of the user or the condition of the user. The readings from the sensor may be in real-time or collected over a period of time. Reference item **2624** indicates a temperature sensor capable of measuring the ambient temperature around the environmental sensor **2600** and a corresponding temperature sensor display **2625** located on the visual display **2604**. In addition to detecting the local temperature, temperature sensor **2624** can detect both the overall body temperature and a body part temperature if placed at different points on the body. For example, change in temperature in the wrists can signal medical problems such as hypothermia and running the environmental sensor housing containing the sensor **2624** across the forehead can detect core body temperature. The sensor **2624** can also detect the temperature of objects when placed on or in proximity to them (e.g., such as the temperature of a coffee mug). Reference item **2626** indicates a radio frequency specific absorption rate (RF SAR) sensor and indicator **2627** located on the visual display which measures the rate at which energy is absorbed by the human body. In addition, there could be a plurality of embedded antennas **2628** in the environmental sensor housing **2602** and the band **2622**. Broad-

band antennas **2628** collect RF signals which are then forwarded to a logarithmic amplifier (i.e., log amp) **2630** which is connected to high dynamic power range sensor **2632**. The data collected is analyzed in processor **2608** and shown on display **2627** on the screen of the environmental sensor. The environmental sensor **2600** includes a ultraviolet (UV) radiation sensor **2634** that detects the amount of UV absorption by the human body. UV is produced by the sun and can result in skin cancer. This sensor **2634** and UV rate indicator **2636** help users avoid UV radiation for a prolonged period of time. The environmental sensor **2600** includes a carbon monoxide sensor **2638** detects the presence of carbon monoxide (CO) gas in order to prevent carbon monoxide poisoning. Oxygen detector **2640** detects and displays the oxygen levels in the atmosphere around the environmental sensor **2600**. Display **2641** shows the oxygen levels. Air particle detector **2642** is configured to detect hazardous air pollutants (HAP) that reduce air quality and the results are shown on indicator **2643** on the visual display. Light sensors in the environmental sensor could be used to predict HAPs. The light sensors could be connected to one or a plurality of ultrasound actuators that would clean the light sensors and allow restart of the collection process. Noise level detector **2644** has noise level speakers that track environmental noise. It is important to collect data on noise and display on an indicator **2645** so that the user can, for example, protect their hearing. The noise level detector **2644** may also be used for sleep tracking patterns to help insomnia patients understand their sleep patterns. Data can then be sent directly to the patient's doctor. Sensor **2646** is a heart rate monitor that checks the heartbeat of the wearer and displays on indicator **2647** the current heart rate in beats per minute and/or puts out a signal that an irregular heartbeat is occurring. Sensor **2648** detects pollen and pet bacteria by periodically sampling the air surrounding the environmental sensor and displaying on indicator **2649**. Humidity levels in the surrounding air may be detected by sensor **2650** and shown on indicator **2651**. The environmental sensor **2600** has an alarm and vibration device **2652** and indicator **2653** that allows for both type of annunciators to be set and heard and/or felt by the operator. The environmental sensor **2600** may have an internal GPS **2654** or rely on base station towers to provide the location of the environmental sensor **2600**. In addition, the environmental sensor may have an accelerometer **2656** that may be used to (along with the GPS **2654**) detect the height of the environmental sensor **2600** from the ground. Sensors **2634**, **2638**, **2640**, **2642**, **2644**, **2646**, **2648**, **2650**, **2652**, **2654**, and **2656** are connected through bus **2620** to processor **2608** for purposes of analysis. The collection of data from a plurality of environmental sensors **2600** further allows for analysis of environmental conditions on a global scale in approximately real-time. Temperature change could be detected with much finer detail across large areas. The environmental sensor **2600** may have all or a combination of a plurality of the sensors listed in the discussion above.

[0071] FIG. 28 shows the environmental sensor **2600** in an operational environment. In this embodiment, environmental sensor **2600** monitors vital signs (such as heart rate using sensor **2646**) of a person **2800**. In memory **2610**, the environmental sensor may have stored the medical history of the person **2800**. The medical history could be encoded into identifications in the environmental sensor **2600**. FIG. 28 shows the person **2800** wearing the environmental sensor **2600** has fallen in the bathroom of a dwelling **2802**. Handy Base Station **2804** is located in the bathroom. The Handy

Base Station (HBS) is described in detail in U.S. patent application Ser. No. 14/658,183, filed on Mar. 14, 2015, entitled "Handy Base Station System, Device and Method" which is owned by the Assignee of this Application and is hereby incorporated by reference. The HBS may be a lamp housing that in addition to providing light through LEDs may contain a processor and a plurality of wireless communication modems to link the HBS with a base station and a network (e.g., Internet). The HBS may have any combination (or all) of a plurality of modems such as WWAN, WLAN, WiFi, WiFi Direct and Bluetooth. HBS **2804** receives a wireless communication from the environmental sensor **2600** which obtained a reading from its accelerometer **2656** that based on the height and location (see FIG. 29) of the environmental sensor **2600** or the rapid height change, the person **2800** has taken a fall. HBS **2804** is programmed to send a message to the environmental sensor **2600** for display on the visual display screen **2604** asking the person if they are okay or if they need an ambulance. In an alternative embodiment, the HBS **2804** may have a speaker to request a response from the person **2800** and act based on if a response is received. If the person does not respond to either a message or a voice communication from the HBS **2804** within a predetermined time (e.g., 1-2 minutes), the HBS will send a 911 request over wireless link **2806** to a 911 operator center **2806** for an ambulance. In another embodiment, if a fall occurs, the environmental sensor **2600** itself could also automatically send out a 911 request using its wireless communication system **2614**. In this instance, the wireless communication system could go into high power mode to send a signal to a base station and also send the medical history and vital signs of the person **2800**.

[0072] In this disclosure, devices that are described as in "communication" with each other or "coupled" to each other need not be in continuous communication with each other or in direct physical contact, unless expressly specified otherwise. On the contrary, such devices need only transmit to each other as necessary or desirable, and may actually refrain from exchanging data most of the time. For example, a machine in communication with or coupled with another machine via the Internet may not transmit data to the other machine for long period of time (e.g. weeks at a time). In addition, devices that are in communication with or coupled with each other may communicate directly or indirectly through one or more intermediaries.

[0073] Although process (or method) steps may be described or claimed in a particular sequential order, such processes may be configured to work in different orders. In other words, any sequence or order of steps that may be explicitly described or claimed does not necessarily indicate a requirement that the steps be performed in that order unless specifically indicated. Further, some steps may be performed simultaneously despite being described or implied as occurring non-simultaneously (e.g., because one step is described after the other step) unless specifically indicated. Moreover, the illustration of a process by its depiction in a drawing does not imply that the illustrated process is exclusive of other variations and modifications thereto, does not imply that the illustrated process or any of its steps are necessary to the embodiment(s), and does not imply that the illustrated process is preferred.

[0074] The foregoing description and embodiments have been presented for purposes of illustration and description and are not intended to be exhaustive or to limit the embodiments in any sense to the precise form disclosed. Also, many

modifications and variations are possible in light of the above teaching. The embodiments were chosen and described to best explain the principles of the disclosure and its practical application to thereby enable others skilled in the art to best use the various embodiments disclosed herein and with various modifications suited to the particular use contemplated. The actual scope of the invention is to be defined by the following claims.

1. A structure configured to connect to a mobile computing device, the structure comprising:

a cavity capable of holding the mobile computing device;
a power source located exterior to and coupled to the cavity and to a plurality of modules located in the structure and capable of providing power to the plurality of modules;
and

wherein the plurality of modules include at least one wireless modem which allows the case to wirelessly transmit and receive signals and a medical sensor.

2. The structure of claim 1, further comprising:

an internal database capable of storing a user's health records.

3. The structure of claim 1, wherein the medical sensor is able to analyze samples received through a port located on the case.

4. The structure of claim 3, wherein the medical sensor is configured to perform the analysis using one of the group consisting of: light, radio frequencies, a microarray, biochip, and ultrasound.

5. The structure of claim 1, further comprising:

a biometric input camera configured to analyze an eye.

6. The structure of claim 1, further comprising:

an electrocardiogram mounted on the case and configured to measure the heart.

7. An environmental sensor apparatus comprising:

a housing having a processor coupled to a visual touch screen display, a wireless communication system and a plurality of sensors; and

wherein at least one of the plurality of sensors is an air environment monitor which detects the air environment surrounding the housing, analyzes the results in a processor, and displays results on the visual touch screen display.

8. The environmental sensor apparatus of claim 7, further comprising:

an indicator on the visual touch screen display to show the current time;

9. The environmental sensor apparatus of claim 7, further comprising:

a wireless communication system which allows the housing to wirelessly transmit and receive signals; and

wherein the wireless communication system has a low power transmit mode to conserve the power source and a high power transmit mode to draw more power from the power source and transmit the wireless signal farther than in the lower power transmit mode.

10. The environmental sensor apparatus of claim 7, further comprising:

a temperature sensor able to detect a body temperature of a wearer of the housing.

11. The environmental sensor apparatus of claim 7, further comprising:

a temperature sensor able to detect a local temperature surrounding the housing.

12. The environmental sensor apparatus of claim 7, wherein the plurality of sensors further comprise:

an atmospheric pressure sensor capable of measuring an atmospheric pressure surrounding the housing;

the processor configured to analyze the results from the atmospheric pressure sensor; and

an indicator on the visual touch screen display to show the atmospheric pressure surrounding the housing.

13. The environmental sensor apparatus of claim 7, further comprising:

a first wireless communication system which allows the housing to wirelessly transmit and receive signals from a second wireless communication system of another environmental sensor apparatus.

14. The environmental sensor apparatus of claim 7, wherein the plurality of sensors further comprising:

a radio frequency sensor capable of measuring a radio frequency specific absorption rate;

the processor configured to analyze the results from the radio frequency sensor; and

an indicator on the visual touch screen display to show the rate at which energy is being absorbed by the wearer of the housing.

15. The environmental sensor apparatus of claim 14, further comprising:

a band for attaching the housing to a body part; and

a plurality of embedded antennas in the housing and the band which are coupled to the processor and collect radio frequency signals.

16. The environmental sensor apparatus of claim 7 wherein the plurality of sensors further comprise:

an ultra violet radiation sensor capable of measuring ultra violet radiation;

the processor configured to analyze the results from the ultra violet sensor; and

an indicator on the visual touch screen display to show the rate at which ultra violet radiation is being absorbed by the wearer of the housing.

17. The environmental sensor apparatus of claim 7 wherein the plurality of sensors further comprise:

a carbon monoxide level sensor capable of measuring carbon monoxide levels in the atmosphere surrounding the housing;

the processor configured to analyze the results from the carbon monoxide sensor; and

an indicator on the visual touch screen display to show levels of carbon monoxide in the atmosphere surrounding the housing.

18. The environmental sensor apparatus of claim 7 wherein the plurality of sensors further comprise:

an oximetric sensor capable of measuring oxygen levels in a sample;

the processor configured to analyze the results from the oximetric sensor; and

an indicator on the visual touch screen display to show levels of oxygen in the sample.

19. The environmental sensor apparatus of claim 7 wherein the plurality of sensors further comprise:

an air particle sensor capable of measuring air pollutants in the atmosphere surrounding the housing; the processor configured to analyze the results from the air particle sensor; and an indicator on the visual touch screen display to show levels of air pollutants in the atmosphere surrounding the housing;

a noise level sensor capable of measuring noise levels in the atmosphere surrounding the housing; the processor configured to analyze the results from the noise level sensor; and an indicator on the visual touch screen display to show levels of carbon noise surrounding the housing; and

a vital signs monitor to detect vital signs of the wearer; a global position satellite (GPS) sensor to determine the location of the housing; and an accelerometer to detect the height of the housing from ground; and the processor configured to analyze the data from the vital signs monitor, GPS sensor and the accelerometer to determine if the wearer has fallen to the ground.

20. A system comprising:

an environmental sensor apparatus comprising:

a housing having a processor coupled to a visual touch screen display, a wireless communication system and a plurality of sensors;

wherein the plurality of sensors include a vital signs monitor to detect

* * * * *

专利名称(译)	具有多个模块化功能的个人云		
公开(公告)号	US20160106370A1	公开(公告)日	2016-04-21
申请号	US14/961862	申请日	2015-12-07
申请(专利权)人(译)	MICRO MOBIO CORPORATION		
当前申请(专利权)人(译)	MICRO MOBIO CORPORATION		
[标]发明人	FILIPOVIC ZLATKO AURELIO WANG WEIPING WANG ADAM JAMES		
发明人	FILIPOVIC, ZLATKO AURELIO WANG, WEIPING WANG, ADAM JAMES		
IPC分类号	A61B5/00 H04B1/3827 A61B5/11 A61B3/14 A61B5/0404 A61B5/01 H04B1/3888 H04M1/02		
CPC分类号	A61B5/6898 H04B1/3888 H04B1/385 H04M1/0254 A61B3/14 A61B5/0404 A61B2562/0219 A61B5/748 A61B5/01 A61B5/6831 A61B5/1112 A61B2560/0252 A61B2560/0257 A61B5/742 A61B5/1117 A61B5/0022 A61B5/02438 A61B2560/0242 G06F1/1628 G06F1/163 G06F1/1632 G06F1/1633 G06F1/1698 G06F1/183 G06F21/32 G06F21/70 H02J7/025 H04M1/185 H04M1/72527 H04M1/7253 H04W4/80 H04W4/90 H04W84/04 H04W84/12 H04W88/08		
优先权	61/705383 2012-09-25 US		
其他公开文献	US9554751		
外部链接	Espacenet USPTO		

摘要(译)

用于便携式计算设备的个人云结构，例如平板个人计算机（PC），移动电话，便携式媒体播放器等。个人云结构可以配备存储器，网络连接，双向无线充电，外部存储器插槽，外部连接和其他组件以创建便携式个人云。

