



(19) **United States**
(12) **Patent Application Publication**
Feldman et al.

(10) **Pub. No.: US 2015/0265192 A1**
(43) **Pub. Date: Sep. 24, 2015**

(54) **METHOD AND APPARATUS FOR
DETECTING FALSE HYPOGLYCEMIC
CONDITIONS**

(60) Provisional application No. 61/256,920, filed on Oct. 30, 2009.

Publication Classification

(71) Applicant: **Abbott Diabetes Care Inc.**, Alameda, CA (US)

(51) **Int. Cl.**
A61B 5/145 (2006.01)
A61B 5/1486 (2006.01)
A61B 5/00 (2006.01)
A61B 5/01 (2006.01)

(72) Inventors: **Benjamin Jay Feldman**, Berkeley, CA (US); **Adam Heller**, Austin, TX (US); **Namvar Kiaie**, Danville, CA (US)

(52) **U.S. Cl.**
CPC *A61B 5/14532* (2013.01); *A61B 5/01* (2013.01); *A61B 5/1451* (2013.01); *A61B 5/14546* (2013.01); *A61B 5/14865* (2013.01); *A61B 5/746* (2013.01)

(73) Assignee: **Abbott Diabetes Care Inc.**, Alameda, CA (US)

(21) Appl. No.: **14/730,077**

(57) **ABSTRACT**

(22) Filed: **Jun. 3, 2015**

Embodiments of the present disclosure include detecting a concurrent occurrence of a decrease in monitored analyte level and a corresponding decrease in monitored on-skin temperature, confirming a presence of an impending hypoglycemic condition, and asserting a notification corresponding to the confirmed impending hypoglycemic condition. Devices, methods, systems and kits incorporating the same are also provided.

Related U.S. Application Data

(60) Continuation of application No. 13/477,026, filed on May 21, 2012, now Pat. No. 9,050,041, which is a division of application No. 12/916,481, filed on Oct. 29, 2010, now Pat. No. 8,185,181.

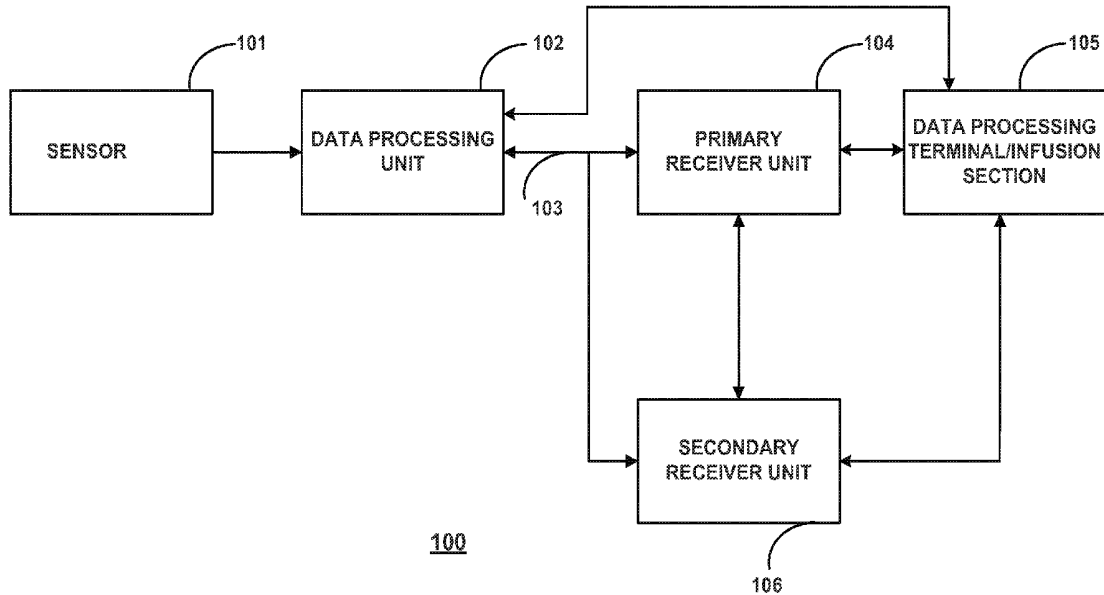

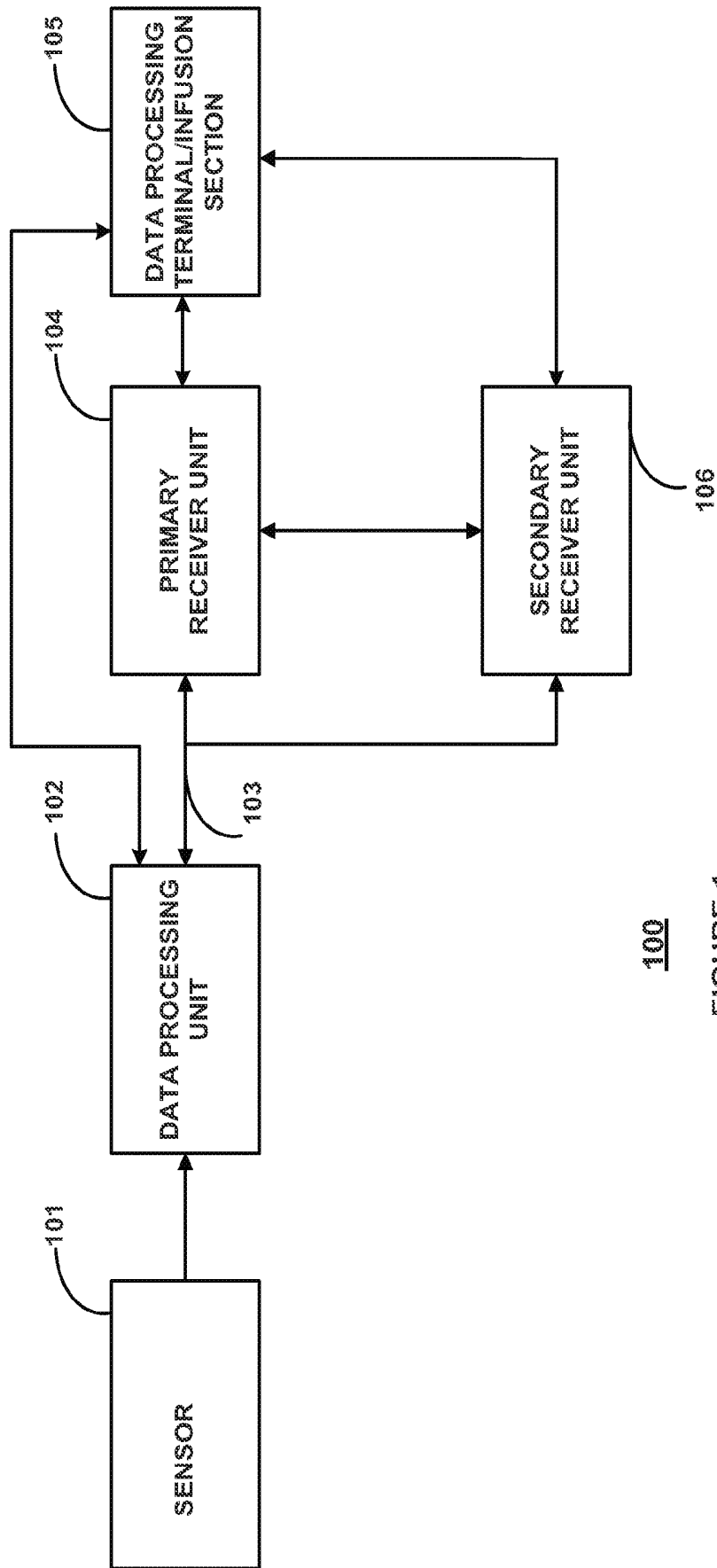

100
FIGURE 1

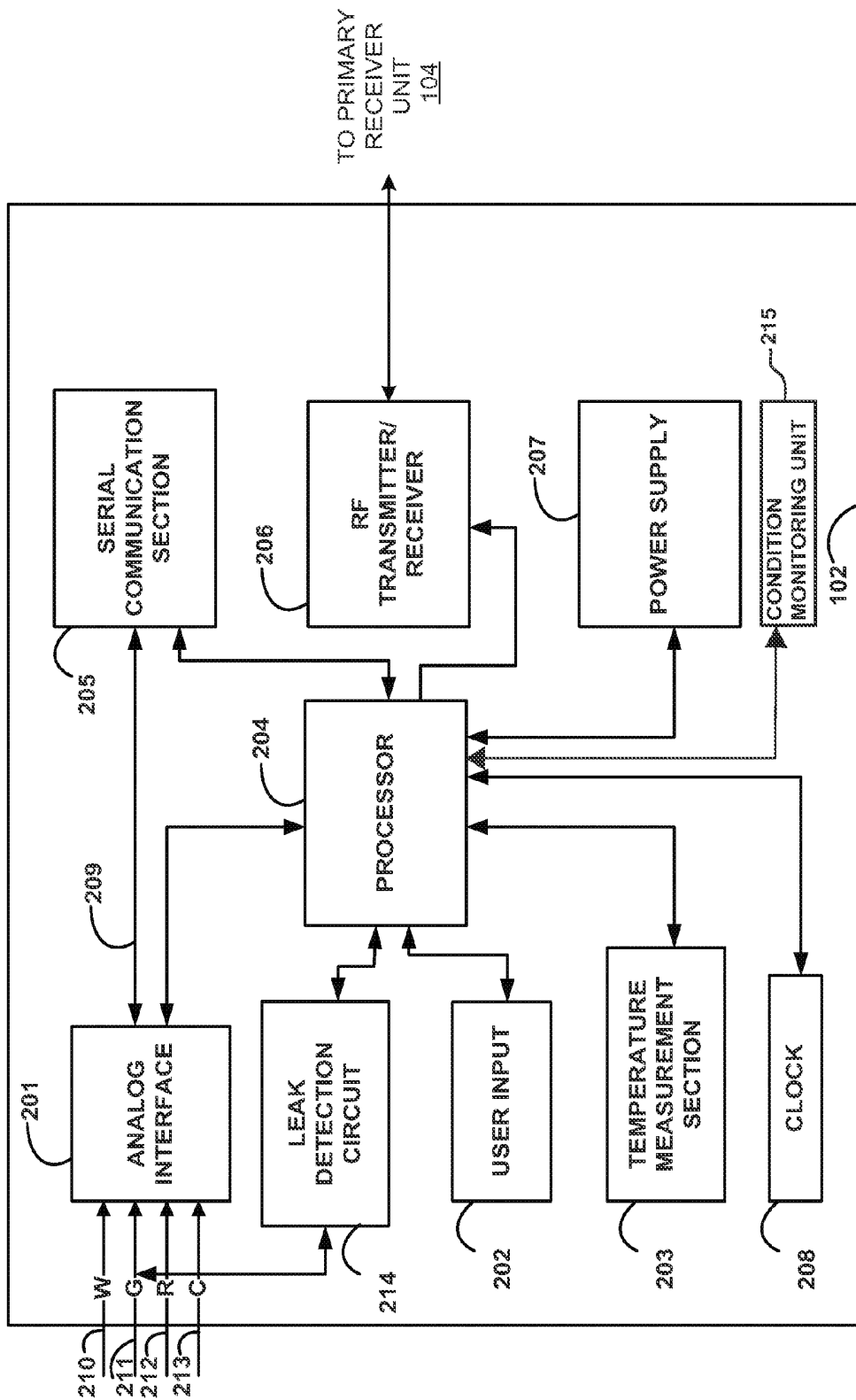

FIGURE 2

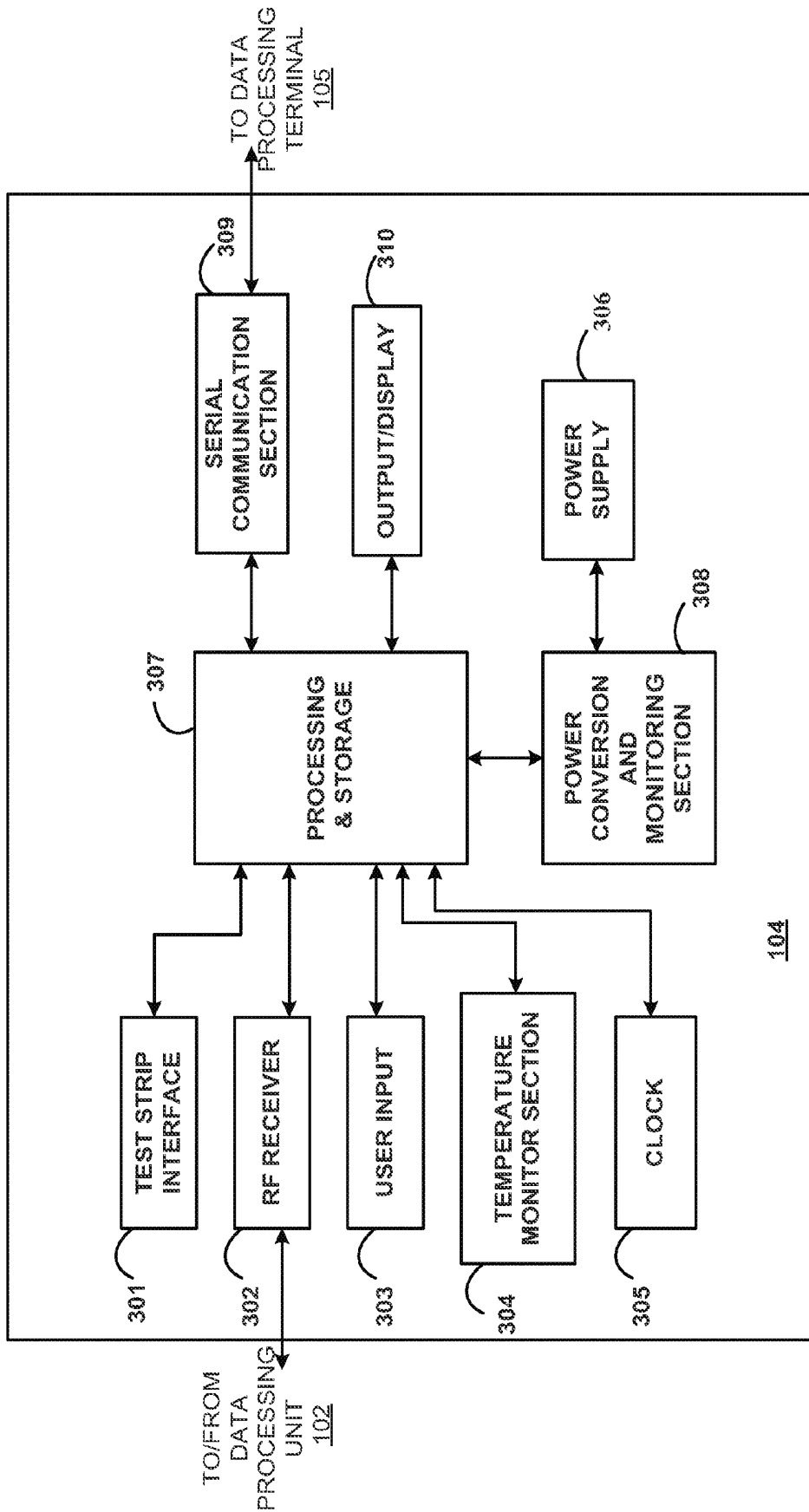

FIGURE 3

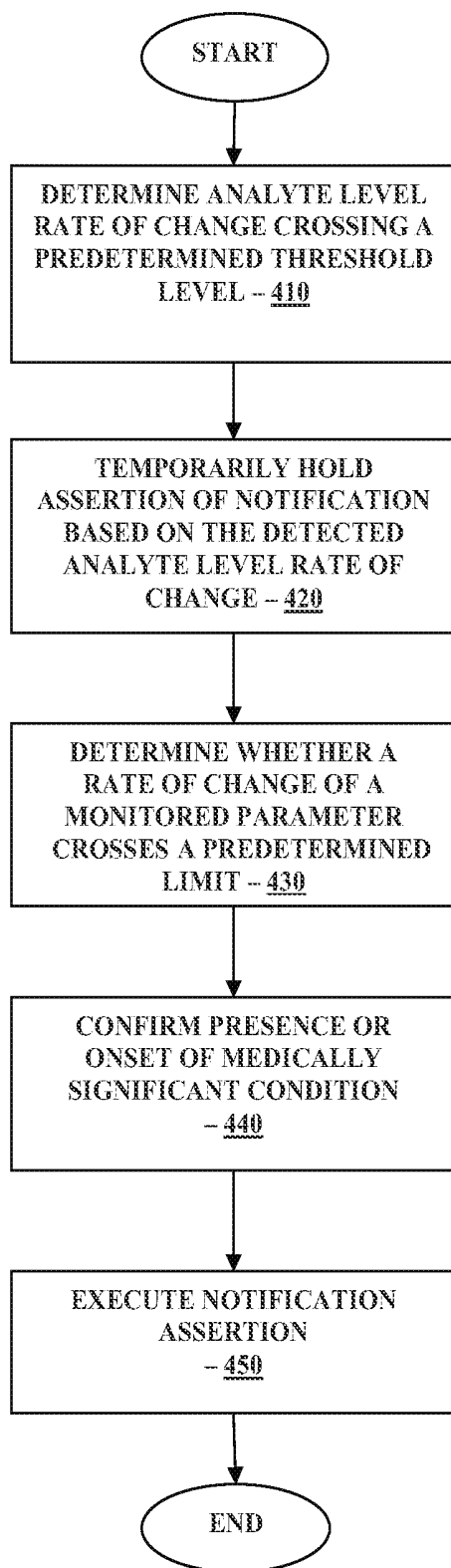

FIGURE 4

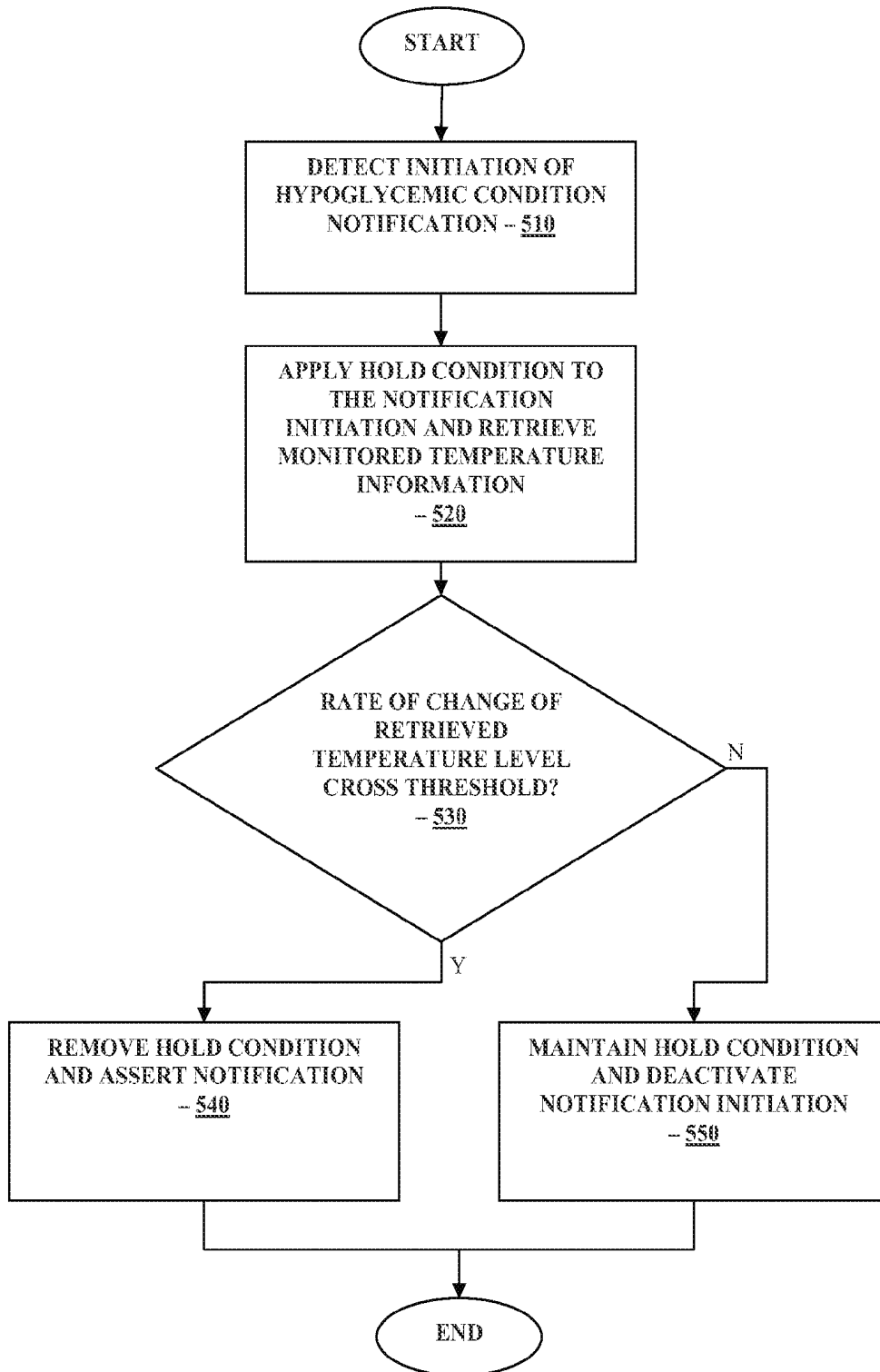

FIGURE 5

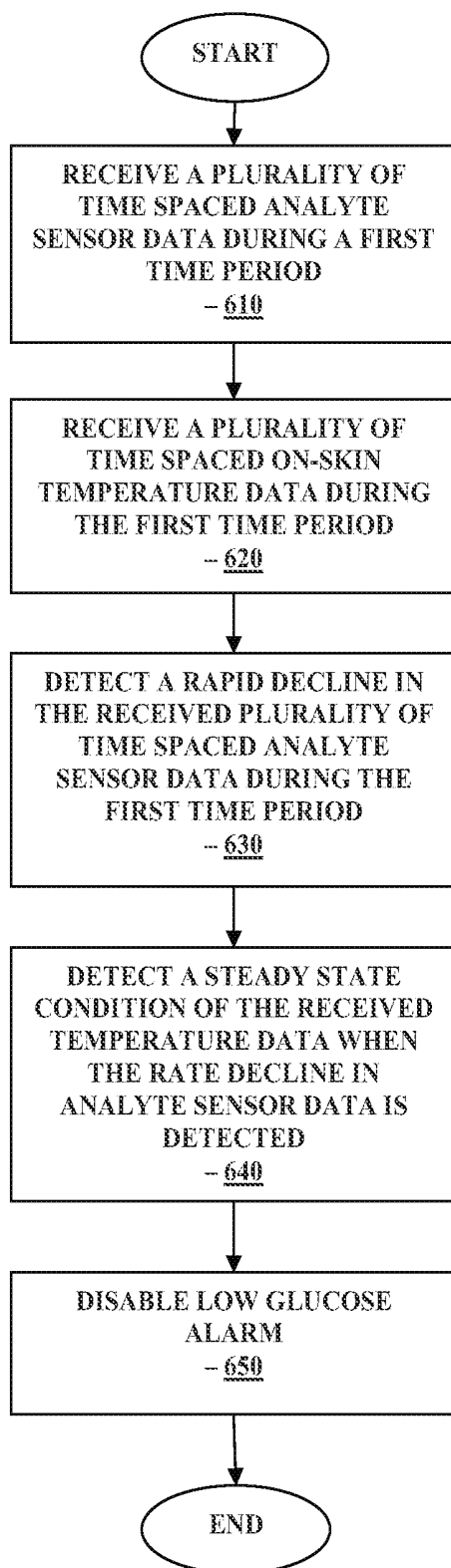

FIGURE 6

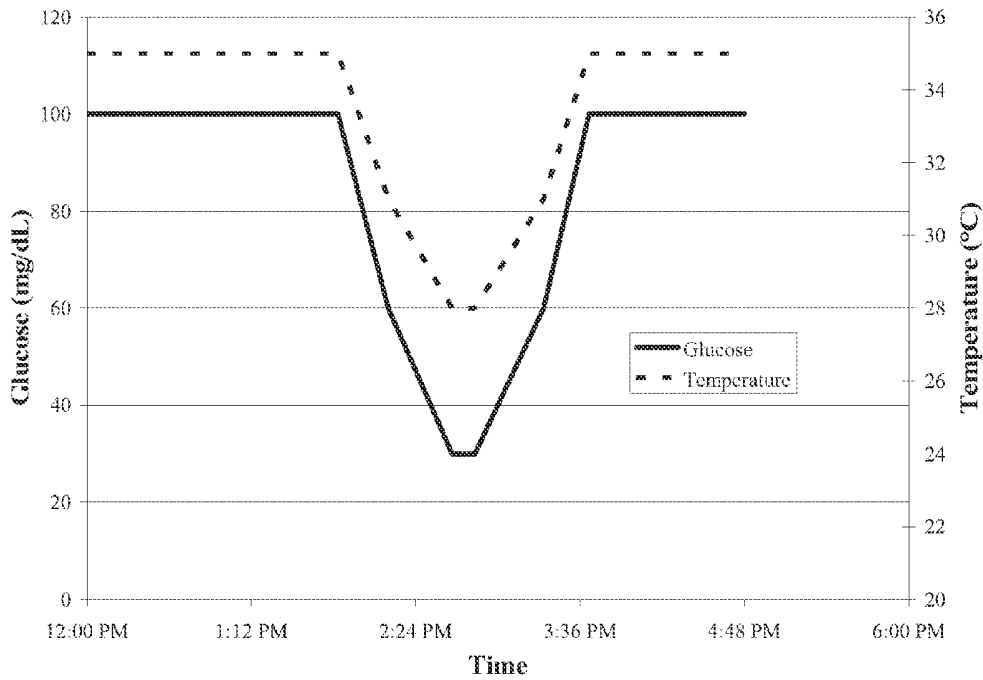

FIGURE 7

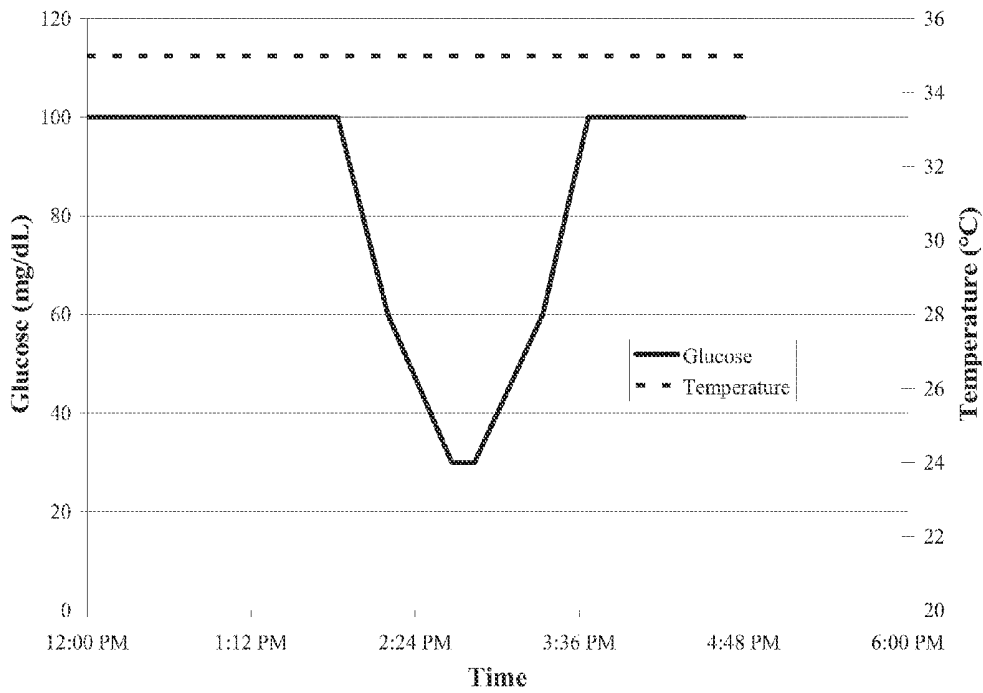

FIGURE 8

METHOD AND APPARATUS FOR DETECTING FALSE HYPOGLYCEMIC CONDITIONS

RELATED APPLICATION

[0001] The present application is a continuation of U.S. patent application Ser. No. 13/477,026 filed May 21, 2012, now U.S. Pat. No. 9,050,041, which is a divisional of U.S. patent application Ser. No. 12/916,481 filed Oct. 29, 2010, now U.S. Pat. No. 8,185,181, which claims the benefit of U.S. Provisional Application No. 61/256,920 filed Oct. 30, 2009, entitled "Method and Apparatus for Detecting False Hypoglycemic Conditions", the disclosures of each of which are incorporated herein by reference for all purposes.

BACKGROUND

[0002] For diabetic patients, it is desirable and often necessary to detect symptoms related to hypoglycemic condition, or the onset of such condition. If not treated in a timely manner, hypoglycemia (or commonly associated with low blood sugar level and sometimes referred to as "insulin shock") will have detrimental if not lethal effect on the patient. As insulin therapy becomes more prevalent for the treatment of diabetes mellitus, the detection of the onset of such conditions is significant.

[0003] When a diabetic person experiences hypoglycemic condition, often, the person will experience increased heart rate, perspiration, involuntary shaking, rapid decline in body temperature, paleness, and over the course of a period of hours, the declining blood sugar level may impact the brain functions, potentially resulting in dizziness, hindered bodily coordination, undesirable modification in behavior and the like. Death or permanent brain damage is not uncommon if the declining blood sugar level is left untreated.

[0004] Commercially available continuous glucose monitoring systems provide tools for diabetic patients to continuously monitor the glucose levels and provide on-going feedback to the patient to take corrective action. Such systems use glucose sensors which at times exhibit inaccuracies. That is, there are times when the glucose sensor may falsely indicate a low glucose reading, triggering a false warning to the user. The false indications, sometimes referred to as sensor signal dropouts, may be attributable to a variety of factors, such as inherent inaccuracies in the system, the instability of the sensor during the initial time period of use, changes in the sensor's environment, pressure on a blood vessel supplying glucose to the tissue in which the sensor is implanted, noise in the system, and the like. It has been found that such false positive indication of low glucose readings generated by the sensor in use occur more often during night time. This in turn causes a significant inconvenience or disadvantage to the user or the patient if alarms or notifications are associated with low glucose measurements and are triggered during night time, when in fact the glucose level of the patient or the user is not low and the triggered alarm or notification was a false alarm.

SUMMARY

[0005] In view of the foregoing, in aspects of the present disclosure, methods, systems, apparatus and kits are provided which reduce the occurrence of false alarms or notifications to the user associated with false hypoglycemic condition detection based on data from analyte sensors. In particular, in aspects of the present disclosure, a user's glucose level is

monitored in conjunction with the temperature and/or perspiration level of the patient, and the fluctuations of the glucose level and the temperature and/or perspiration level is monitored such that, when a potential hypoglycemic condition or a potential impending hypoglycemic condition is detected, the presence of such potential conditions is confirmed before the associated notification or alarm is asserted.

[0006] In addition to the monitored temperature or perspiration level, within the scope of the present disclosure, other physiological parameters may be monitored for confirming the presence of hypoglycemic condition, such as, for example, a user's heart rate, detected tremor, or oxygen saturation level of the user's blood.

[0007] A method in accordance with one embodiment includes receiving a plurality of time spaced analyte related data monitored by an analyte sensor in fluid contact with an analyte during a first time period, detecting when one or more of the received plurality of time spaced analyte related data crosses a predetermined analyte threshold level during the first time period, receiving a plurality of time spaced temperature data during the first time period, determining a rate of change of the received plurality of time spaced temperature data and detecting when the determined rate of change crosses a predetermined rate of temperature change; and asserting a notification when the determined rate of change of the received plurality of the time spaced temperature data reaches the predetermined rate of temperature change and when the one or more of the received plurality of time spaced analyte related data reaches the predetermined threshold analyte level during the first time period.

[0008] A method in accordance with another embodiment includes receiving a plurality of time spaced analyte related data monitored by an analyte sensor in fluid contact with an analyte during a first time period, detecting when one or more of the received plurality of time spaced analyte related data reaches a predetermined analyte threshold level during the first time period, receiving a plurality of time spaced temperature data during the first time period, detecting when one or more of the time spaced temperature related data crosses a predetermined threshold temperature level during the first time period, and asserting a notification when the one or more of the received plurality of time spaced analyte related data reaches a predetermined threshold analyte level and when the one or more of the plurality of time spaced temperature related data reaches the predetermined temperature threshold level during the first time period.

[0009] In still another aspect, a method in accordance with certain embodiments of the present disclosure includes monitoring a variation in on-skin temperature in proximity to a transcutaneously positioned analyte sensor having at least a portion in fluid contact with an analyte during a monitoring time period, detecting the variation in the monitored temperature exceeding a predetermined threshold level, confirming a presence of a medically significant condition when the detected variation in the monitored temperature exceeds the predetermined threshold level, and asserting a notification associated with the medically significant condition when it is confirmed, wherein confirming the presence of the medically significant condition includes determining a variation in the monitored analyte level exceeding the predetermined threshold level based on comparing a slope indicative of the change in the monitored analyte level substantially to a slope indicative of the change in the monitored on-skin temperature variation.

[0010] A method in still another embodiment includes detecting a concurrent occurrence of a decrease in monitored analyte level and a corresponding decrease in monitored on-skin temperature, confirming a presence of an impending hypoglycemic condition, and asserting a notification corresponding to the confirmed impending hypoglycemic condition.

[0011] A method of confirming hypoglycemic condition in a patient in yet still a further embodiment includes monitoring a directional change in glucose level based on data stream received from an analyte sensor during a monitoring time period, monitoring a directional change in a first physiological parameter during the monitoring time period, monitoring a directional change in a second physiological parameter during the monitoring time period, detecting an initialization of a hypoglycemic alarm based, at least in part, on the directional change of the monitored glucose level, and comparing the directional change in one or more of the first or the second physiological parameters relative to the directional change in the glucose level prior to the assertion of the hypoglycemic alarm.

[0012] An apparatus in accordance with one embodiment includes one or more processors, and a memory for storing instructions which, when executed by the one or more processors, causes the one or more processors to receive a plurality of time spaced analyte related data monitored by an analyte sensor in fluid contact with an analyte during a first time period, determine a rate of change of the received plurality of time spaced analyte related data, receive a plurality of time spaced temperature data during the first time period, determine a rate of change of the received plurality of time spaced temperature data, compare the determined rate of change of the received plurality of the time spaced temperature data to the predetermined threshold level when the determined rate of change of the received plurality of time spaced analyte related data exceeds a predetermined threshold level, and assert a notification when the determined rate of change of the received plurality of the time spaced temperature data exceeds the predetermined threshold level.

[0013] An apparatus in accordance with still another aspect includes one or more processors, and a memory for storing instructions which, when executed by the one or more processors, causes the one or more processors to monitor a variation in on-skin temperature in proximity to a transcutaneously positioned analyte sensor having at least a portion in fluid contact with an analyte during a monitoring time period, detect the variation in the monitored temperature exceeding a predetermined threshold level, confirm a presence of a medically significant condition when the detected variation in the monitored temperature exceeds the predetermined threshold level, and assert a notification associated with the medically significant condition when it is confirmed, wherein the memory for storing instructions which, when executed by the one or more processors, causes the one or more processors to determine a variation in the monitored analyte level exceeding the predetermined threshold level based on comparing a slope indicative of the change in the monitored analyte level substantially to a slope indicative of the change in the monitored on-skin temperature variation.

[0014] An apparatus in accordance with still another aspect includes one or more processors, and a memory for storing instructions which, when executed by the one or more processors, causes the one or more processors to detect a concurrent occurrence of a decrease in monitored analyte level

and a corresponding decrease in monitored on-skin temperature, confirm a presence of an impending hypoglycemic condition, and assert a notification corresponding to the confirmed impending hypoglycemic condition.

[0015] An apparatus in still yet a further embodiment includes one or more processors, and a memory for storing instructions which, when executed by the one or more processors, causes the one or more processors to monitor a directional change in glucose level based on data stream received from an analyte sensor during a monitoring time period, monitor a directional change in a first physiological parameter during the monitoring time period, monitor a directional change in a second physiological parameter during the monitoring time period, detect an initialization of a hypoglycemic alarm based, at least in part, on the directional change of the monitored glucose level, and compare the directional change in one or more of the first or the second physiological parameters relative to the directional change in the glucose level prior to the assertion of the hypoglycemic alarm.

[0016] In this manner, in aspects of the present disclosure, the occurrence of false notifications associated with the presence of hypoglycemic condition, impending hypoglycemic condition, or onset of hypoglycemic condition is reduced, providing robustness to the glucose monitoring system.

[0017] These and other features, objects and advantages of the present disclosure will become apparent to those persons skilled in the art upon reading the details of the present disclosure as more fully described below.

BRIEF DESCRIPTION OF THE DRAWINGS

[0018] A detailed description of various aspects, features and embodiments of the present disclosure is provided herein with reference to the accompanying drawings, which are briefly described below. The drawings are illustrative and are not necessarily drawn to scale, with some components and features being exaggerated for clarity. The drawings illustrate various aspects or features of the present disclosure and may illustrate one or more embodiment(s) or example(s) of the present disclosure in whole or in part. A reference numeral, letter, and/or symbol that is used in one drawing to refer to a particular element or feature may be used in another drawing to refer to a like element or feature. Included in the drawings are the following:

[0019] FIG. 1 shows a block diagram of an embodiment of a data monitoring and management system with which a sensor according to the present disclosure is usable;

[0020] FIG. 2 shows a block diagram of an embodiment of the data processing unit of the data monitoring and management system of FIG. 1;

[0021] FIG. 3 shows a block diagram of an embodiment of the receiver/monitor unit of the data monitoring and management system of FIG. 1;

[0022] FIG. 4 is a flowchart illustrating a routine associated with determining false signal attenuation of an analyte sensor in one aspect of the present disclosure;

[0023] FIG. 5 is a flowchart illustrating a routine associated with determining false signal attenuation of an analyte sensor in another aspect of the present disclosure;

[0024] FIG. 6 is a flowchart illustrating a routine associated with determining false signal attenuation of an analyte sensor in a further aspect of the present disclosure;

[0025] FIG. 7 is graphical illustration of the monitored glucose level and the corresponding temperature level during the same time period confirming a hypoglycemic event; and

[0026] FIG. 8 is a graphical illustration of the monitored glucose level and the corresponding temperature level during the same time period indicating a false hypoglycemic event.

INCORPORATION BY REFERENCE

[0027] Patents, applications and/or publications described herein, including the following patents, applications and/or publications are incorporated herein by reference for all purposes: U.S. Pat. Nos. 4,545,382, 4,711,245, 5,262,035, 5,262,305, 5,264,104, 5,320,715, 5,356,786, 5,509,410, 5,543,326, 5,593,852, 5,601,435, 5,628,890, 5,820,551, 5,822,715, 5,899,855, 5,918,603, 6,071,391, 6,103,033, 6,120,676, 6,121,009, 6,134,461, 6,143,164, 6,144,837, 6,161,095, 6,175,752, 6,270,455, 6,284,478, 6,299,757, 6,338,790, 6,377,894, 6,461,496, 6,503,381, 6,514,460, 6,514,718, 6,540,891, 6,560,471, 6,579,690, 6,591,125, 6,592,745, 6,600,997, 6,605,200, 6,605,201, 6,616,819, 6,618,934, 6,650,471, 6,654,625, 6,676,816, 6,730,200, 6,736,957, 6,746,582, 6,749,740, 6,764,581, 6,773,671, 6,881,551, 6,893,545, 6,932,892, 6,932,894, 6,942,518, 7,041,468, 7,167,818, and 7,299,082, U.S. Published Application Nos. 2004/0186365, now U.S. Pat. No. 7,811,231, 2005/0182306, now U.S. Pat. No. 8,771,183, 2006/0025662, now U.S. Pat. No. 7,740,581, 2006/0091006, 2007/0056858, now U.S. Pat. No. 8,298,389, 2007/0068807, now U.S. Pat. No. 7,846,311, 2007/0095661, 2007/0108048, now U.S. Pat. No. 7,918,975, 2007/0199818, now U.S. Pat. No. 7,811,430, 2007/0227911, now U.S. Pat. No. 7,887,682, 2007/0233013, 2008/0066305, now U.S. Pat. No. 7,895,740, 2008/0081977, now U.S. Pat. No. 7,618,369, 2008/0102441, now U.S. Pat. No. 7,822,557, 2008/0148873, now U.S. Pat. No. 7,802,467, 2008/0161666, 2008/0267823, and 2009/0054748, now U.S. Pat. No. 7,885,698, U.S. patent application Ser. Nos. 11/461,725, now U.S. Pat. No. 7,866,026, Ser. Nos. 12/131,012, 12/393,921, 12/242,823, now U.S. Pat. No. 8,219,173, Ser. No. 12/363,712, now U.S. Pat. No. 8,346,335, Ser. Nos. 12/495,709, 12/698,124, 12/698,129, 12/714,439, 12/794,721, now U.S. Pat. No. 8,595,607, Ser. Nos. 12/807,278, 12/842,013, and 12/871,901, now U.S. Pat. No. 8,514,086, and U.S. Provisional Application Nos. 61/238,646, 61/246,825, 61/247,516, 61/249,535, 61/317,243, 61/345,562, 61/325,260 and 61/361,374.

DETAILED DESCRIPTION

[0028] Before the present disclosure is described, it is to be understood that this disclosure is not limited to particular embodiments described, as such may, of course, vary. It is also to be understood that the terminology used herein is for the purpose of describing particular embodiments only, and is not intended to be limiting, since the scope of the present disclosure will be limited only by the appended claims.

[0029] Where a range of values is provided, it is understood that each intervening value, to the tenth of the unit of the lower limit unless the context clearly dictates otherwise, between the upper and lower limit of that range and any other stated or intervening value in that stated range, is encompassed within the disclosure. The upper and lower limits of these smaller ranges may independently be included in the smaller ranges as also encompassed within the disclosure, subject to any specifically excluded limit in the stated range. Where the stated range includes one or both of the limits, ranges excluding either or both of those included limits are also included in the disclosure.

[0030] It must be noted that as used herein and in the appended claims, the singular forms “a”, “an”, and “the” include plural referents unless the context clearly dictates otherwise.

[0031] As will be apparent to those of skill in the art upon reading this disclosure, each of the individual embodiments described and illustrated herein has discrete components and features which may be readily separated from or combined with the features of any of the other several embodiments without departing from the scope or spirit of the present disclosure.

[0032] Generally, embodiments of the present disclosure relate to methods and devices for detecting at least one analyte, such as glucose, in body fluid. Embodiments relate to the continuous and/or automatic in vivo monitoring of the level of one or more analytes using a continuous analyte monitoring system that includes an analyte sensor for the in vivo detection, of an analyte, such as glucose, lactate, and the like, in a body fluid. Embodiments include wholly implantable analyte sensors and analyte sensors in which only a portion of the sensor is positioned under the skin and a portion of the sensor resides above the skin, e.g., for contact to a control unit, transmitter, receiver, transceiver, processor, etc. At least a portion of a sensor may be, for example, subcutaneously positionable in a patient for the continuous or semi-continuous monitoring of a level of an analyte in a patient's interstitial fluid. For the purposes of this description, semi-continuous monitoring and continuous monitoring will be used interchangeably, unless noted otherwise.

[0033] The sensor response may be correlated and/or converted to analyte levels in blood or other fluids. In certain embodiments, an analyte sensor may be positioned in contact with interstitial fluid to detect the level of glucose, which may be used to infer the glucose level in the patient's bloodstream. Analyte sensors may be insertable into a vein, artery, or other portion of the body containing fluid. Embodiments of the analyte sensors of the subject disclosure may be configured for monitoring the level of the analyte over a time period which may range from minutes, hours, days, weeks, or longer.

[0034] In aspects of the present disclosure, temperature, perspiration or other characteristics of a patient such as, for example, other measurable characteristics are monitored concurrently with the monitored analyte level, and used to, in one embodiment, either confirm or reject notifications associated with the medically significant condition such as the onset or impending hypoglycemic condition initially detected based on the monitored analyte level.

[0035] In one aspect, the hypoglycemic condition may be associated with a low blood glucose level such as, for example, 40-50 mg/dL or less (depending upon, for example, age, gender, and the like). Accordingly, alarms or notifications may be configured, as a default setting or programmed specific to each patient, to be triggered when the monitored glucose level decreases at a rate that approaches the hypoglycemic condition within a defined time period to enable the patient or the user (or the healthcare provider) to timely take corrective actions. For example, each alarm or notification may be programmed to be asserted or triggered when the monitored glucose level reaches approximately 80 to 100 mg/dL, and decreasing at a rate of 2 mg/dL/minute or more. Referring now to the Figures, an exemplary overall analyte monitoring system including the various components is described below.

[0036] FIG. 1 illustrates a data monitoring and management system such as, for example, an analyte (e.g., glucose) monitoring system **100** in accordance with certain embodiments. Embodiments of the subject disclosure are further described primarily with respect to glucose monitoring devices and systems, and methods of glucose detection, for convenience only and such description is in no way intended to limit the scope of the disclosure. It is to be understood that the analyte monitoring system may be configured to monitor a variety of analytes instead of or in addition to glucose, e.g., at the same time or at different times.

[0037] Analytes that may be monitored include, but are not limited to, acetyl choline, amylase, bilirubin, cholesterol, chorionic gonadotropin, creatine kinase (e.g., CK-MB), creatine, creatinine, DNA, fructosamine, glucose, glutamine, growth hormones, hormones, ketone bodies, lactate, oxygen, peroxide, prostate-specific antigen, prothrombin, RNA, thyroid stimulating hormone, and troponin. The concentration of drugs, such as, for example, antibiotics (e.g., gentamicin, vancomycin, and the like), digitoxin, digoxin, drugs of abuse, theophylline, and warfarin, may also be monitored. In those embodiments that monitor more than one analyte, the analytes may be monitored at the same or different times.

[0038] The analyte monitoring system **100** includes a sensor **101**, a data processing unit **102** connectable to the sensor **101**, and a primary receiver unit **104** which is configured to communicate with the data processing unit **102** via a communication link **103**. In certain embodiments, the primary receiver unit **104** may be further configured to transmit data to a data processing terminal **105** to evaluate or otherwise process or format data received by the primary receiver unit **104**. The data processing terminal **105** may be configured to receive data directly from the data processing unit **102** via a communication link which may optionally be configured for bi-directional communication. Further, the data processing unit **102** may include a transmitter or a transceiver to transmit and/or receive data to and/or from the primary receiver unit **104** and/or the data processing terminal **105** and/or optionally the secondary receiver unit **106**.

[0039] The electrochemical sensors of the present disclosure may employ any suitable measurement technique, e.g., may detect current, may employ potentiometry, etc. Techniques may include, but are not limited to, amperometry, coulometry, and voltammetry. In some embodiments, sensing systems may be optical, colorimetric, and the like.

[0040] Also shown in FIG. 1 is an optional secondary receiver unit **106** which is operatively coupled to the communication link **103** and configured to receive data transmitted from the data processing unit **102**. The secondary receiver unit **106** may be configured to communicate with the primary receiver unit **104**, as well as the data processing terminal **105**. The secondary receiver unit **106** may be configured for bi-directional wireless communication with each of the primary receiver unit **104** and the data processing terminal **105**. As discussed in further detail below, in certain embodiments the secondary receiver unit **106** may be a de-featured receiver as compared to the primary receiver unit **104**, i.e., the secondary receiver unit **106** may include a limited or minimal number of functions and features as compared with the primary receiver unit **104**. As such, the secondary receiver unit **106** may include a smaller (in one or more, including all, dimensions), compact housing or embodied in a device such as a wrist watch, arm band, etc., for example.

[0041] Alternatively, the secondary receiver unit **106** may be configured with the same or substantially similar functions and features as the primary receiver unit **104**. The secondary receiver unit **106** may include a docking portion to be mated with a docking cradle unit for placement by, e.g., the bedside for nighttime monitoring, and/or a bi-directional communication device. A docking cradle may recharge a power supply.

[0042] Only one sensor **101**, data processing unit **102** and data processing terminal **105** are shown in the embodiment of the analyte monitoring system **100** illustrated in FIG. 1. However, it will be appreciated by one of ordinary skill in the art that the analyte monitoring system **100** may include more than one sensor **101** and/or more than one data processing unit **102**, and/or more than one data processing terminal **105**. Multiple sensors may be positioned in a patient for analyte monitoring at the same or different times. In certain embodiments, analyte information obtained by a first positioned sensor may be employed as a comparison to analyte information obtained by a second sensor. This may be useful to confirm or validate analyte information obtained from one or both of the sensors. Such redundancy may be useful if analyte information is contemplated in critical therapy-related decisions.

[0043] The analyte monitoring system **100** may be a continuous monitoring system or semi-continuous. In a multi-component environment, each component may be configured to be uniquely identified by one or more of the other components in the system so that communication conflict may be readily resolved between the various components within the analyte monitoring system **100**. For example, unique identification codes (IDs), communication channels, and the like, may be used.

[0044] In certain embodiments, the sensor **101** is physically positioned in and/or on the body of a user whose analyte level is being monitored. The sensor **101** may be configured to continuously or semi-continuously sample the analyte level of the user automatically (without the user initiating the sampling), based on a programmed interval such as, for example, but not limited to, once every minute, once every five minutes and so on, and convert the sampled analyte level into a corresponding signal for transmission by the data processing unit **102**. The data processing unit **102** is coupleable to the sensor **101** so that both devices are positioned in or on the user's body, with at least a portion of the analyte sensor **101** positioned transcutaneously. The data processing unit may include a fixation element such as adhesive or the like to secure it to the user's body. A mount (not shown) attachable to the user and mateable with the unit **102** may be used. For example, a mount may include an adhesive surface. The data processing unit **102** performs data processing functions, where such functions may include, but are not limited to, filtering and encoding of data signals, each of which corresponds to a sampled analyte level of the user, for transmission to the primary receiver unit **104** via the communication link **103**. In one embodiment, the sensor **101** or the data processing unit **102** or a combined sensor/data processing unit may be wholly implantable under the skin layer of the user.

[0045] In certain embodiments, the primary receiver unit **104** may include a signal interface section including an RF receiver and an antenna that is configured to communicate with the data processing unit **102** via the communication link **103**, and a data processing section for processing the received data from the data processing unit **102** such as data decoding,

error detection and correction, data clock generation, data bit recovery, etc., or any combination thereof.

[0046] In operation, the primary receiver unit 104 in certain embodiments is configured to synchronize with the data processing unit 102 to uniquely identify the data processing unit 102, based on, for example, an identification information of the data processing unit 102, and thereafter, to continuously or semi-continuously receive signals transmitted from the data processing unit 102 associated with the monitored analyte levels detected by the sensor 101. Referring again to FIG. 1, the data processing terminal 105 may include a personal computer, a portable computer such as a laptop or a handheld device (e.g., personal digital assistants (PDAs), telephone such as a cellular phone (e.g., a multimedia and Internet-enabled mobile phone such as an iPhone, Blackberry device or similar phone), mp3 player, pager, global position system (GPS)) drug delivery device, each of which may be configured for data communication with the receiver via a wired or a wireless connection. Additionally, the data processing terminal 105 may further be connected to a data network (not shown) for storing, retrieving, updating, and/or analyzing data corresponding to the detected analyte level of the user.

[0047] The data processing terminal 105 may include an infusion device such as an insulin infusion pump or the like, which may be configured to administer insulin to patients, and which may be configured to communicate with the primary receiver unit 104 for receiving, among others, the measured analyte level. Alternatively, the primary receiver unit 104 may be configured to integrate an infusion device therein so that the primary receiver unit 104 is configured to administer insulin (or other appropriate drug) therapy to patients, for example, for administering and modifying basal profiles, as well as for determining appropriate boluses for administration based on, among others, the detected analyte levels received from the data processing unit 102. An infusion device may be an external device or an internal device (wholly implantable in a user).

[0048] In certain embodiments, the data processing terminal 105, which may include an insulin pump, may be configured to receive the analyte signals from the data processing unit 102, and thus, incorporate the functions of the primary receiver unit 104 including data processing for managing the patient's insulin therapy and analyte monitoring. In certain embodiments, the communication link 103 as well as one or more of the other communication interfaces shown in FIG. 1, may use one or more of an RF communication protocol, an infrared communication protocol, a Bluetooth® enabled communication protocol, an 802.11x wireless communication protocol, or an equivalent wireless communication protocol which would allow secure, wireless communication of several units (for example, per HIPAA requirements), while avoiding potential data collision and interference.

[0049] FIG. 2 shows a block diagram of an embodiment of a data processing unit of the data monitoring and detection system shown in FIG. 1. The data processing unit 102 thus may include one or more of an analog interface 201 configured to communicate with the sensor 101 (FIG. 1), a user input 202, and a temperature measurement section 203, each of which is operatively coupled to a processor 204 such as a central processing unit (CPU). User input and/or interface components may be included or a data processing unit may be free of user input and/or interface components. In certain embodiments, one or more application-specific integrated circuits (ASIC) may be used to implement one or more func-

tions or routines associated with the operations of the data processing unit (and/or receiver unit) using for example one or more state machines and buffers.

[0050] Further shown in FIG. 2 are a transmitter serial communication section 205 and an RF transmitter 206, each of which is also operatively coupled to the processor 204. The RF transmitter 206, in some embodiments, may be configured as an RF receiver or an RF transmitter/receiver, such as a transceiver, to transmit and/or receive data signals. Moreover, a power supply 207, such as a battery, may also be provided in the data processing unit 102 to provide the necessary power for the data processing unit 102. Additionally, as can be seen from the Figure, clock 208 may be provided to, among others, supply real time information to the processor 204.

[0051] As can be seen in the embodiment of FIG. 2, the sensor 101 (FIG. 1) includes four contacts, three of which are electrodes—working electrode (W) 210, guard contact (G) 211, reference electrode (R) 212, and counter electrode (C) 213, each operatively coupled to the analog interface 201 of the data processing unit 102. In certain embodiments, each of the working electrode (W) 210, guard contact (G) 211, reference electrode (R) 212, and counter electrode (C) 213 may be made using a non-corroding conductive material that may be applied by, e.g., chemical vapor deposition (CVD), physical vapor deposition, sputtering, reactive sputtering, printing, coating, ablating (e.g., laser ablation), painting, dip coating, etching, and the like. Materials include, but are not limited to, carbon (such as graphite), gold, iridium, ruthenium, palladium, platinum, rhenium, rhodium, silver, mixtures thereof, and alloys thereof, and metallic oxides, like ruthenium dioxide or iridium dioxide, of these elements.

[0052] In certain embodiments, a unidirectional input path is established from the sensor 101 (FIG. 1) and/or manufacturing and testing equipment to the analog interface 201 of the data processing unit 102, while a unidirectional output is established from the output of the RF transmitter 206 of the data processing unit 102 for transmission to the primary receiver unit 104. In this manner, a data path is shown in FIG. 2 between the aforementioned unidirectional input and output via a dedicated link 209 from the analog interface 201 to serial communication section 205, thereafter to the processor 204, and then to the RF transmitter 206. As such, in certain embodiments, via the data path described above, the data processing unit 102 is configured to transmit to the primary receiver unit 104 (FIG. 1), via the communication link 103 (FIG. 1), processed and encoded data signals received from the sensor 101 (FIG. 1). Additionally, the unidirectional communication data path between the analog interface 201 and the RF transmitter 206 discussed above allows for the configuration of the data processing unit 102 for operation upon completion of the manufacturing process as well as for direct communication for diagnostic and testing purposes.

[0053] The processor 204 may be configured to transmit control signals to the various sections of the data processing unit 102 during the operation of the data processing unit 102. In certain embodiments, the processor 204 also includes memory (not shown) for storing data such as the identification information for the data processing unit 102, as well as the data signals received from the sensor 101. The stored information may be retrieved and processed for transmission to the primary receiver unit 104 under the control of the processor 204. Furthermore, the power supply 207 may include a commercially available battery.

[0054] The data processing unit **102** is also configured such that the power supply section **207** is capable of providing power to the data processing unit **102** for a minimum period of time, e.g., at least about one month, e.g., at least about three months or more, of continuous operation. The minimum time period may be after (i.e., in addition to), a period of time, e.g., up to about eighteen months, of being stored in a low- or no-power (non-operating) mode. In certain embodiments, this may be achieved by the processor **204** operating in low power modes in the non-operating state, for example, drawing no more than minimal current, e.g., approximately 1 μ A of current or less. In certain embodiments, a manufacturing process of the data processing unit **102** may place the data processing unit **102** in the lower power, non-operating state (i.e., post-manufacture sleep mode). In this manner, the shelf life of the data processing unit **102** may be significantly improved. Moreover, as shown in FIG. 2, while the power supply unit **207** is shown as coupled to the processor **204**, and as such, the processor **204** is configured to provide control of the power supply unit **207**, it should be noted that within the scope of the present disclosure, the power supply unit **207** is configured to provide the necessary power to each of the components of the data processing unit **102** shown in FIG. 2.

[0055] Referring back to FIG. 2, the power supply section **207** of the data processing unit **102** in one embodiment may include a rechargeable battery unit that may be recharged by a separate power supply recharging unit (for example, provided in the receiver unit **104**) so that the data processing unit **102** may be powered for a longer period of usage time. In certain embodiments, the data processing unit **102** may be configured without a battery in the power supply section **207**, in which case the data processing unit **102** may be configured to receive power from an external power supply source (for example, a battery, electrical outlet, etc.) as discussed in further detail below.

[0056] Referring yet again to FIG. 2, a temperature detection section **203** of the data processing unit **102** is configured to monitor the temperature of the skin near the sensor insertion site. The temperature reading may be used to adjust the analyte readings obtained from the analog interface **201**. In a further aspect, the temperature measurement or reading generated from the temperature detection section **203** may be used in conjunction with the received analyte data to determine or confirm a monitored condition such as an impending or onset of hypoglycemic condition as discussed in further detail below. For example, the temperature measurement section may include a thermistor to monitor the on-skin (or ambient) temperature in direct or indirect contact with the patient's skin. Example embodiments of temperature measurement section are provided in, for example, U.S. Pat. No. 6,175,752, and application Ser. No. 11/026,766 entitled "Method and Apparatus for Providing Temperature Sensor Module in a Data Communication System," each assigned to the assignee of the present application, and the disclosure of each of which are incorporated herein by reference for all purposes.

[0057] In a further embodiment, the temperature measurement or reading may be generated or determined from a different area of the body such as the ear canal, rectum, mouth, other body cavity, or forehead using a suitable temperature measuring device or components which incorporate the temperature measurement functionalities and capable of transmitting (wirelessly or via wired connection) the determined temperature information to the receiver unit **104/106**

(FIG. 1) and/or data processing terminal/infusion section **105** (FIG. 1) for further processing.

[0058] Referring back to FIG. 2, the data processing unit **102** may also include a condition monitoring unit **215** in signal communication with the processor **204**, and configured to monitor one or more physiological or other characteristics of the patient or the user of the data processing unit **102**. For example, the perspiration level may be monitored by the condition monitoring unit **215** in one embodiment by detecting or determining conductance signal levels that vary depending upon the presence or absence of perspiration on skin, for example, using electrodes or probes or contacts on the skin of the patient. In one aspect, the electrodes, probes or contacts to determine or monitor the one or more physiological characteristics such as level of perspiration may be provided on the housing of the data processing unit **102**, or alternatively, may be provided as a separate unit that is configured to provide or transfer the monitored characteristics information or data to the processor **204** of the data processing unit **102**. Accordingly, in one aspect, the microprocessor based logic provided to the processor **204** may be configured to process the detected conductance signal levels to determine the presence or absence of perspiration and/or, to determine the level of and change in perspiration based on, for example, monitored or detected conductance signal level.

[0059] Referring back to FIG. 2, the RF transmitter **206** of the data processing unit **102** may be configured for operation in a certain frequency band, e.g., the frequency band of 315 MHz to 322 MHz, for example, in the United States. The operating frequency band may vary depending upon the location of use, communication protocol used, components used to implement the RF communication, and accordingly, the present disclosure contemplates varying ranges of operating frequency bands. Further, in certain embodiments, the RF transmitter **206** is configured to modulate the carrier frequency by performing, e.g., Frequency Shift Keying and Manchester encoding, and/or other protocol(s). In certain embodiments, the data transmission rate is set for efficient and effective transmission. For example, in certain embodiments the data transmission rate may be about 19,200 symbols per second, with a minimum transmission range for communication with the primary receiver unit **104**.

[0060] Also shown is a leak detection circuit **214** coupled to the guard contact (G) **211** and the processor **204** in the data processing unit **102** of the data monitoring and management system **100**. The leak detection circuit **214** may be configured to detect leakage current in the sensor **101** to determine whether the measured sensor data is corrupt or whether the measured data from the sensor **101** is accurate. Such detection may trigger a notification to the user.

[0061] FIG. 3 shows a block diagram of an embodiment of a receiver/monitor unit such as the primary receiver unit **104** of the data monitoring and management system shown in FIG. 1. The primary receiver unit **104** may include one or more of: a blood glucose test strip interface **301** for in vitro testing, an RF receiver **302**, an input **303**, a temperature detection section **304**, and a clock **305**, each of which is operatively coupled to a processing and storage section **307**. The primary receiver unit **104** also includes a power supply **306** operatively coupled to a power conversion and monitoring section **308**. Further, the power conversion and monitoring section **308** is also coupled to the receiver processor **307**. Moreover, also shown are a receiver serial communication section **309**, and an output **310**, each operatively coupled to

the processing and storage unit **307**. The receiver may include user input and/or interface components or may be free of user input and/or interface components.

[0062] In certain embodiments having a test strip interface **301**, the interface includes a glucose level testing portion to receive a blood (or other body fluid sample) glucose test or information related thereto. For example, the interface may include a test strip port to receive an in vitro glucose test strip. The device may determine the glucose level of the test strip, and optionally display (or otherwise report or output) the glucose level on the output **310** of the primary receiver unit **104**. Any suitable test strip may be employed, e.g., test strips that only require a very small amount (e.g., one microliter or less, e.g., 0.5 microliter or less, e.g., 0.1 microliter or less), of applied sample to the strip in order to obtain accurate glucose information, e.g. FreeStyle® and Precision® blood glucose test strips from Abbott Diabetes Care Inc. Glucose information obtained by the in vitro glucose testing device may be used for a variety of purposes, computations, etc. For example, the information may be used to calibrate sensor **101** (however, calibration of the subject sensors may not be necessary), confirm results of the sensor **101** to increase the confidence thereof (e.g., in instances in which information obtained by sensor **101** is employed in therapy related decisions), etc. Exemplary blood glucose monitoring systems are described, e.g., in U.S. Pat. Nos. 6,071,391; 6,120,676; 6,338,790; and 6,616,819; and in U.S. application Ser. Nos. 11/282,001, now U.S. Pat. No. 7,918,975; and Ser. No. 11/225,659, now U.S. Pat. No. 8,298,389, the disclosures of which are herein incorporated by reference.

[0063] The RF receiver **302** is configured to communicate, via the communication link **103** (FIG. 1) with the RF transmitter **206** of the data processing unit **102**, to receive encoded data signals from the data processing unit **102** for, among others, signal mixing, demodulation, and other data processing. The input **303** of the primary receiver unit **104** is configured to allow the user to enter information into the primary receiver unit **104** as needed. In one aspect, the input **303** may include keys of a keypad, a touch-sensitive screen, and/or a voice-activated input command unit, and the like. The temperature monitor section **304** is configured to provide temperature information of the primary receiver unit **104** to the receiver processing and storage unit **307**, while the clock **305** provides, among others, real time information to the receiver processing and storage unit **307**.

[0064] Each of the various components of the primary receiver unit **104** shown in FIG. 3 is powered by the power supply **306** (and/or other power supply) which, in certain embodiments, includes a battery. Furthermore, the power conversion and monitoring section **308** is configured to monitor the power usage by the various components in the primary receiver unit **104** for effective power management and may alert the user, for example, in the event of power usage which renders the primary receiver unit **104** in sub-optimal operating conditions. An example of such sub-optimal operating condition may include, for example, operating the vibration output mode (as discussed below) for a period of time thus substantially draining the power supply **306** while the processing and storage unit **307** (thus, the primary receiver unit **104**) is turned on. Moreover, the power conversion and monitoring section **308** may additionally be configured to include a reverse polarity protection circuit such as a field effect transistor (FET) configured as a battery activated switch.

[0065] The serial communication section **309** in the primary receiver unit **104** is configured to provide a bi-directional communication path from the testing and/or manufacturing equipment for, among others, initialization, testing, and configuration of the primary receiver unit **104**. Serial communication section **309** can also be used to upload data to a computer, such as time-stamped blood glucose data. The communication link with an external device (not shown) can be made, for example, by cable, infrared (IR) or RF link. The output **310** of the primary receiver unit **104** is configured to provide, among others, a graphical user interface (GUI) such as a liquid crystal display (LCD) for displaying information. Additionally, the output **310** may also include an integrated speaker for outputting audible signals as well as to provide vibration output as commonly found in handheld electronic devices, such as mobile telephones, pagers, etc. In certain embodiments, the primary receiver unit **104** also includes an electro-luminescent lamp configured to provide backlighting to the output **310** for output visual display in dark ambient surroundings.

[0066] Referring back to FIG. 3, the primary receiver unit **104** may also include a storage section such as a programmable, non-volatile memory device as part of the processing and storage unit **307**, or provided separately in the primary receiver unit **104**, operatively coupled to the processor. The processing and storage unit **307** may be configured to perform Manchester decoding (or other protocol(s)) as well as error detection and correction upon the encoded data signals received from the data processing unit **102** via the communication link **103**.

[0067] In further embodiments, the data processing unit **102** and/or the primary receiver unit **104** and/or the secondary receiver unit **106**, and/or the data processing terminal/infusion section **105** may be configured to receive the blood glucose value from a wired connection or wirelessly over a communication link from, for example, a blood glucose meter. In further embodiments, a user manipulating or using the analyte monitoring system **100** (FIG. 1) may manually input the blood glucose value using, for example, a user interface (for example, a keyboard, keypad, voice commands, and the like) incorporated in the one or more of the data processing unit **102**, the primary receiver unit **104**, secondary receiver unit **106**, or the data processing terminal/infusion section **105**.

[0068] In certain embodiments, the data processing unit **102** (FIG. 1) is configured to detect the current signal from the sensor **101** (FIG. 1) and optionally the skin and/or ambient temperature near the sensor **101**, which may be preprocessed by, for example, the data processing unit processor **204** (FIG. 2) and transmitted to the receiver unit (for example, the primary receiver unit **104** (FIG. 1)) at least at a predetermined time interval, such as for example, but not limited to, once per minute, once every two minutes, once every five minutes, or once every ten minutes. Although specific time frames have been mentioned, it is contemplated that the predetermined time interval may correspond to any amount of time selected by the patient, user or healthcare provider. Additionally, the data processing unit **102** may be configured to perform sensor insertion detection and data quality analysis, information pertaining to which may also be transmitted to the receiver unit **104** periodically at the predetermined time interval. In turn, the receiver unit **104** may be configured to perform, for

example, skin temperature compensation as well as calibration of the sensor data received from the data processing unit **102**.

[0069] Additional detailed descriptions are provided in U.S. Pat. Nos. 5,262,035; 5,262,035; 5,264,104; 5,262,305; 5,320,715; 5,593,852; 6,103,033; 6,134,461; 6,175,752; 6,560,471; 6,579,690; 6,605,200; 6,654,625; 6,746,582; and 6,932,894; and in U.S. Published Patent Application No. 2004/0186365, now U.S. Patent No. 7,811,231, the disclosures of which are herein incorporated by reference. Description of exemplary methods for forming the sensor is provided in U.S. patents and applications noted herein, including U.S. Patent Nos. 5,262,035; 6,103,033; 6,175,752; and 6,284,478, the disclosures of which are herein incorporated by reference. Examples of sensing layers that may be employed are described in U.S. patents and applications noted herein, including, e.g., in U.S. Patent Nos. 5,262,035; 5,264,104; 5,543,326; 6,605,200; 6,605,201; 6,676,819; and 7,299,082; the disclosures of which are herein incorporated by reference.

[0070] The subject analyte measurement systems may include an alarm system that, e.g., based on information from a processor, warns the patient of a potentially detrimental condition of the analyte. For example, if glucose is the analyte, an alarm system may warn a user of conditions such as hypoglycemia and/or hyperglycemia and/or impending hypoglycemia, and/or impending hyperglycemia. An alarm system may be triggered when analyte levels approach, reach or exceed a threshold value. An alarm system may also, or alternatively, be activated when the rate of change, or the acceleration of the rate of change in the analyte level increase or decrease, approaches, reaches or exceeds a threshold rate or acceleration. A system may also include system alarms that notify a user of system information such as battery condition, calibration, sensor dislodgment, sensor malfunction, etc. Alarms may be, for example, auditory and/or visual. Other sensory-stimulating alarm systems may be used including alarm systems which heat, cool, vibrate, or produce a mild electrical shock when activated.

[0071] The subject disclosure also includes sensors used in sensor-based drug delivery systems. The system may provide a drug to counteract the high or low level of the analyte in response to the signals from one or more sensors. Alternatively, the system may monitor the drug concentration to ensure that the drug remains within a desired therapeutic range. The drug delivery system may include one or more (e.g., two or more) sensors, a processing unit such as a transmitter, a receiver/display unit, and a drug administration system. In some cases, some or all components may be integrated in a single unit. A sensor-based drug delivery system may use data from the one or more sensors to provide necessary input for a control algorithm/mechanism to adjust the administration of drugs, e.g., automatically or semi-automatically. As an example, a glucose sensor may be used to control and adjust the administration of insulin from an external or implanted insulin pump.

[0072] Referring back to the Figures, FIG. 4 is a flowchart illustrating a routine associated with determining false signal attenuation of an analyte sensor in one aspect of the present disclosure. As shown, in one embodiment, a rate of change of analyte level such as monitored glucose level variation is determined or compared against a predetermined threshold level (**410**). In one aspect, the predetermined threshold level may be pre-programmed and stored in a memory storage device of the data processing unit **102** (FIG. 1) and/or the

processing and storage unit **307** (FIG. 3) of the receiver **104/106**. In other aspects, the predetermined threshold level may be programmable or adjustable by the user or the healthcare provider. In still a further aspect, the predetermined threshold level may include a plurality of threshold levels, each corresponding to a particular time of day (for example, day time, meal time, or night time) or an event such as exercise, meal, sleeping, intake of medication and the like.

[0073] Referring again to FIG. 4, when it is determined that the rate of change of the monitored analyte level crosses a predetermined threshold level (**410**) (for example, by exceeding an upper threshold level, or by falling below a lower threshold level), a temporary hold assertion function is called and executed to temporarily hold the assertion of a programmed notification based on the detected analyte level rate of change (**420**). That is, in one aspect, when an alarm or alert notification is programmed to be asserted based on the analyte level rate of change crossing the predetermined threshold, before the assertion of the alarm or alert notification is implemented, the receiver **104** or the data processing unit **102** may be programmed to execute a hold function to temporarily hold off the assertion of the alarm/alert notification.

[0074] Thereafter, as shown in FIG. 4, a rate of change or variation of another monitored parameter is compared against a predetermined limit (pre-programmed or adjusted by the user or the healthcare provider) to determine whether the rate of change of the monitored parameter crosses the predetermined limit (**430**). That is, in one aspect, a monitored temperature and/or perspiration level is retrieved and the rate of change of the temperature level is determined and compared against the predetermined limit. In one aspect, the time period of determining the rate of change of the monitored parameter is programmed or set to coincide with the time period of the monitored analyte level (based on which the alarm/alert notification is initiated). While the level of temperature or perspiration is described above as the monitored parameter which is determined upon detection of an alarm/alert notification based on the analyte level rate of change, within the scope of the present disclosure, other physiological and/or environmental parameters may be determined or analyzed individually, or in combination with one or more of the temperature level or the perspiration level.

[0075] Based on the determination of whether the rate of change of the monitored parameter crosses the predetermined limit (**430**), the presence/absence or onset of a medically significant condition associated with the alarm/alert notification discussed above, is confirmed (**440**), and thereafter upon confirmation of the presence of the medically significant condition, the hold assertion function is removed and the alarm/alert notification is output to, for example, notify the user or the healthcare provider (**450**). In one embodiment, the alarm/alert notification may include one or more of an audible notification (a discrete sound or a series of sounds or tones that either vary in intensity and/or output level), a vibratory notification (which may increase/decrease in the strength of vibration or be maintained at a steady vibration strength), or a visual notification (a numeric, graphical, textual or combinations thereof).

[0076] In this manner, in one aspect of the present disclosure, upon detection of a medically significant condition such as a hypoglycemic condition based on the monitored analyte levels, before any alarm or alert notification is output or presented to the user to take corrective actions, the detection of such condition is confirmed based on one or more other

monitored parameters such as the level or variation of the user's body or on-skin temperature or the level or variation in perspiration. In this manner, the potential for a false positive indication of such alarm or alert condition determined based on the monitored analyte level alone may be reduced by confirmation of such condition based on other physiological and/or environmental parameters associated with the user.

[0077] Moreover, while hypoglycemia is described above, the medically significant condition may include other physiological conditions of the user where supplemental or additional monitored parameters are used to confirm the presence of the medically significant condition prior to notifying the user. Accordingly, the frequency of the false indication of the medically significant condition presence can be reduced and also, the user may be prevented from taking unnecessary corrective actions based on false indications of such condition.

[0078] FIG. 5 is a flowchart illustrating a routine associated with determining false signal attenuation of an analyte sensor in another aspect of the present disclosure. Referring to the Figure, in one aspect, when the initiation of hypoglycemic condition notification is detected (510), a hold condition to the notification is applied and the monitored temperature information is retrieved (520). Thereafter, the rate of change of the retrieved temperature level is compared to a threshold level (530). If it is determined that the determined rate of temperature level change crosses the threshold (530), then the hold condition is removed and the initiated hypoglycemic notification is asserted (540). On the other hand, if the determined rate of temperature level change is determined to not have crossed the threshold (530), then the hold condition is maintained and the initiated hypoglycemic notification is deactivated (550).

[0079] Referring back to FIG. 5, when the monitored temperature information is retrieved (520), in one embodiment, the time period of the retrieved monitored temperature information is determined to substantially coincide with the time period of monitored analyte level based on which the hypoglycemic condition notification is initiated (510). In an alternate embodiment, the time period of the retrieved monitored temperature information may include the time period of the monitored analyte level such that the monitored temperature for processing and/or analysis spans a wider time period range.

[0080] Still alternatively, the time period of the monitored temperature information may be a subset of the time period of the monitored analyte level based on which the hypoglycemic condition notification is initiated. Indeed, the variation in the monitored time period as well as the number of available data sets for the monitored temperature level and the monitored analyte level may vary based on one or more of the frequency of data sampling, the availability of the information, the degree of sensitivity of the temperature detection (e.g., thermistor), and the like.

[0081] FIG. 6 is a flowchart illustrating a routine associated with determining false signal attenuation of an analyte sensor in a further aspect of the present disclosure. As shown, in one embodiment, a plurality of time spaced analyte sensor data during a first time period is received (610). Thereafter, a plurality of time spaced on-skin temperature data during the first time period is received (620). Upon detection of a rapid decline in the received plurality of time spaced analyte sensor data during the first time period (630), the plurality of time spaced on-skin temperature data is analyzed. In one aspect,

rapid decline in the received plurality of time spaced analyte sensor data may include a rate of change of the analyte sensor data at or greater than 2 mg/dL/min. Within the scope of the present disclosure, the rapid decline may include other variations of the rate of change that is greater or less than 2 mg/dL/min. Furthermore, while on skin temperature level monitoring and detection is described above, in accordance with aspects of the present disclosure, any suitable body temperature may be measured and used to confirm or reject the preliminary indication of a hypoglycemic condition.

[0082] Referring back to FIG. 6, upon detection of a steady state condition of the received plurality of time spaced temperature data during the first time period (640), low glucose alarm function (for example, in the data processing unit 102 and/or the receiver unit 104/106, or the data processing terminal/infusion section 105) is disabled (650) indicating that the detected rapid decline in the received plurality of time spaced analyte sensor data during the first time period (630) is not associated with a low glucose condition (or glucose level trending towards a low glucose condition), but rather, a false indication of the low glucose condition or an analyte sensor signal attenuation which may be attributable to parameters associated with the analyte sensor (e.g., unstable sensor), errors in data processing, dislodged sensor or the like. In one aspect, the steady state condition of the received plurality of time spaced temperature data may include variation of the temperature data during the first time period that does not cross a predetermined or preset level. That is, a steady state condition may include a relatively stable temperature information or level during the first time period.

[0083] While monitoring glucose level in addition to monitoring and determining temperature and/or perspiration level as described in conjunction with the various aspects of the present disclosure, other physiological parameters may be monitored and used to confirm or reject the occurrence of hypoglycemic condition. For example, palpitation or variation in heart rate may be monitored using, for example, a heart rate monitor, or the oxygen saturation level may be monitored using, for example, a pulse oximeter, to confirm or reject the occurrence of hypoglycemic condition indicated by the monitored glucose levels. Additional description of pulse oximetry for monitoring oxygen saturation level is provided in U.S. Pat. Nos. 6,606,511 and 6,912,413, disclosures of each of which are incorporated herein by reference. Furthermore, description of heart rate monitors for monitoring the heart rate is provided in U.S. Pat. No. 6,549,756, the disclosure of which is incorporated herein by reference.

[0084] Additionally, tremor may be monitored to confirm the detection of hypoglycemic condition where a variation in the movement may be used to confirm or reject the occurrence of hypoglycemic condition. Additional description of detecting tremor is provided in U.S. Pat. No. 5,293,879, the disclosure of which is incorporated herein by reference. Accordingly, when the monitored glucose level received from the analyte sensor indicates a hypoglycemic condition (or an impending hypoglycemic condition), a detection or variation of one or more of tremor, palpitation, perspiration, temperature or other physiological parameters may be used in conjunction with the sensor data confirm or reject the indication of hypoglycemic condition.

[0085] FIG. 7 is a graphical illustration of the monitored glucose level and the corresponding temperature level during the same time period confirming a hypoglycemic event. In contrast, FIG. 8 provides a graphical illustration of the moni-

tored glucose level and the corresponding temperature level during the same time period indicating a false hypoglycemic event. As shown in these graphical illustrations, in aspects of the present disclosure, when an actual analyte sensor signal attenuation is detected (indicating a low glucose level), the level of the supplemental or additional parameter such as the temperature level is similar attenuated providing a level of correlation between the direction of change of the analyte level and the temperature level (as shown in FIG. 7).

[0086] On the other hand, as shown in FIG. 8, if the analyte sensor signal reported by the sensor is a false indication of the monitored analyte level, the corresponding level of the monitored additional parameter such as the temperature level does not provide the level of correlation as discussed above, but rather, indicates a deviation in the direction of change compared to the direction of change of the monitored analyte level.

[0087] In the manner described, in accordance with the various embodiments of the present disclosure, the occurrence of false alarms associated with analyte sensor signal attenuation may be minimized or mitigated by correlating the monitored analyte level with one or more additional parameters such as temperature or perspiration level. Accordingly, alarm or alert functions associated with monitored analyte levels in accordance with the present disclosure may be asserted when the underlying conditions associated with the alarm or alert function accurately reflects the monitored condition such that the user or the patient is not prompted to take unnecessary corrective actions based on false indication of the monitored condition.

[0088] The various processes described above including the processes operating in the software application execution environment in the analyte monitoring system 100 including the data processing unit 102, the receiver unit 104/106 or the data processing terminal/infusion section 105, performing one or more routines associated with the false analyte sensor signal attenuation determination described in conjunction with FIGS. 4-6, may be embodied as computer programs developed using an object oriented language that allows the modeling of complex systems with modular objects to create abstractions that are representative of real world, physical objects and their interrelationships. The software required to carry out the inventive process, which may be stored in a memory or storage device of the storage unit of the data processing unit 102, the receiver unit 104/106 or the data processing terminal/infusion section 105 in the analyte monitoring system 100, may be developed by a person of ordinary skill in the art and may include one or more computer program products.

[0089] In one embodiment, a method may include receiving a plurality of time spaced analyte related data monitored by an analyte sensor in fluid contact with an analyte during a first time period, detecting when one or more of the received plurality of time spaced analyte related data crosses a predetermined analyte threshold level during the first time period, receiving a plurality of time spaced temperature data during the first time period, determining a rate of change of the received plurality of time spaced temperature data, detecting when the determined rate of change crosses a predetermined rate of temperature change, and asserting a notification when the determined rate of change of the received plurality of the time spaced temperature data reaches the predetermined rate of temperature change and when the one or more of the

received plurality of time spaced analyte related data reaches the predetermined threshold analyte level during the first time period.

[0090] A further embodiment may include determining when the monitored analyte level based on the received plurality of time spaced analyte related data indicates approaching the predetermined analyte threshold level during a second time period.

[0091] The first time period may precede the second time period.

[0092] The asserted notification may include one or more of an audible alert, a vibratory alert, a visual alert, or one or more combinations thereof

[0093] The predetermined analyte threshold level may be associated with one of an impending hypoglycemic condition or an onset of hypoglycemic condition.

[0094] Another aspect may include determining a rate of change of the received plurality of time spaced analyte related data and comparing a slope of the determined rate of change of the received plurality of time spaced analyte related data to a slope of the rate of change of the received plurality of time spaced temperature data.

[0095] The slope of the determined rate of change of the received plurality of analyte related data and the slope of the rate of change of the received plurality of time spaced temperature data may be coincident.

[0096] The asserted notification may include an impending hypoglycemic condition.

[0097] Yet another aspect may include when the determined rate of change of the received plurality of the time spaced temperature data does not exceed the predetermined rate of temperature change, deactivating a notification function.

[0098] The deactivated notification function may include a hypoglycemic alarm.

[0099] Another embodiment may comprise receiving a plurality of time spaced analyte related data monitored by an analyte sensor in fluid contact with an analyte during a first time period, detecting when one or more of the received plurality of time spaced analyte related data crosses a predetermined analyte threshold level during the first time period, receiving a plurality of time spaced temperature data during the first time period, detecting when one or more of the time spaced temperature related data crosses a predetermined threshold temperature level during the first time period, and asserting a notification when the one or more of the received plurality of time spaced analyte related data reaches a predetermined threshold analyte level and when the one or more of the plurality of time spaced temperature related data reaches the predetermined temperature threshold level during the first time period.

[0100] Another embodiment may further include determining when the monitored analyte level based on the received plurality of time spaced analyte related data indicates approaching the predetermined analyte threshold level during a second time period.

[0101] The first time period may precede the second time period.

[0102] The asserted notification may be associated with a medically significant condition.

[0103] The medically significant condition may include an impending hypoglycemic condition.

[0104] Yet another embodiment may comprise monitoring a variation in on-skin temperature in proximity to a transcu-

taneously positioned analyte sensor having at least a portion in fluid contact with an analyte during a monitoring time period, detecting the variation in the monitored temperature exceeding a predetermined threshold level, confirming a presence of a medically significant condition when the detected variation in the monitored temperature exceeds the predetermined threshold level, and asserting a notification associated with the medically significant condition when it is confirmed, wherein confirming the presence of the medically significant condition includes determining a variation in the monitored analyte level exceeding the predetermined threshold level based on comparing a slope indicative of the change in the monitored analyte level substantially to a slope indicative of the change in the monitored on-skin temperature variation.

[0105] In yet another embodiment, a method may comprise detecting a concurrent occurrence of a decrease in monitored analyte level and a corresponding decrease in monitored on-skin temperature, confirming a presence of an impending hypoglycemic condition, and asserting a notification corresponding to the confirmed impending hypoglycemic condition.

[0106] The decrease in the monitored analyte level may include a decrease exceeding approximately 2 mg/dL/minute.

[0107] The decrease in the monitored on-skin temperature may include a temperature decrease exceeding approximately 2° C./15 minutes.

[0108] Detecting the concurrent occurrence may include determining a rate of change of the monitored analyte level during a predetermined time period, determining a rate of change of the monitored on-skin temperature during the predetermined time period, and verifying the determined rate of change of the monitored analyte level and the determined rate of change of the monitored on-skin temperature exceeds a predetermined threshold level substantially at the same time.

[0109] In another embodiment, a method of confirming hypoglycemic condition in a patient may comprise monitoring a directional change in glucose level based on data stream received from an analyte sensor during a monitoring time period, monitoring a directional change in a first physiological parameter during the monitoring time period, monitoring a directional change in a second physiological parameter during the monitoring time period, detecting an initialization of a hypoglycemic alarm based, at least in part, on the directional change of the monitored glucose level, and comparing the directional change in one or more of the first or the second physiological parameters relative to the directional change in the glucose level prior to the assertion of the hypoglycemic alarm.

[0110] The first physiological parameter or the second physiological parameter may be one of a temperature level, a perspiration level, heart rate, detected tremor, or oxygen saturation level.

[0111] The hypoglycemic alarm may be asserted when the glucose level directional change and the first physiological parameter direction change are the same.

[0112] The alarm may be asserted only when the second physiological parameter directional change is opposite the first physiological parameter directional change.

[0113] The monitored directional change in glucose level may have a negative slope.

[0114] The monitored directional change in the first physiological parameter may have a negative slope, and further, the

monitored directional change in the second physiological parameter may have a positive slope.

[0115] The monitoring time period may include approximately five days or seven days.

[0116] The hypoglycemic alarm initialization may be detected when the monitored directional change in glucose level exceeds a predetermined threshold.

[0117] The predetermined threshold may include a decreasing rate of glucose level of approximately 2 mg/dL/minute.

[0118] Comparing the directional change may include temporarily disabling the hypoglycemic alarm initialization based on the comparison.

[0119] The hypoglycemic alarm initialization may be disabled when the directional change of the first and second physiological parameters are the same.

[0120] The hypoglycemic alarm initialization may be disabled when the directional change of the monitored glucose level does not coincide with the directional change of either of the first and second physiological parameters.

[0121] In another embodiment, an apparatus may comprise one or more processors and a memory for storing instructions which, when executed by the one or more processors, causes the one or more processors to receive a plurality of time spaced analyte related data monitored by an analyte sensor in fluid contact with an analyte during a first time period, determine a rate of change of the received plurality of time spaced analyte related data, receive a plurality of time spaced temperature data during the first time period, determine a rate of change of the received plurality of time spaced temperature data, compare the determined rate of change of the received plurality of the time spaced temperature data to the predetermined threshold level when the determined rate of change of the received plurality of time spaced analyte related data exceeds a predetermined threshold level, and assert a notification when the determined rate of change of the received plurality of the time spaced temperature data exceeds the predetermined threshold level.

[0122] The asserted notification may include one or more of an audible alert, a vibratory alert, a visual alert, or one or more combinations thereof

[0123] The predetermined threshold level may include 3% decrease between each adjacent time spaced analyte related data and 3% decrease between each adjacent time temperature data.

[0124] The determined rate of change of the received plurality of time spaced analyte related data and the determined rate of change of the received plurality of time spaced temperature data may be temporally coincident.

[0125] The asserted notification may be associated with a medically significant condition.

[0126] The medically significant condition may include an impending hypoglycemic condition.

[0127] The notification may be asserted only when the determined rate of change of the received plurality of time spaced temperature data and the determined rate of change of the received analyte related data exceeds the predetermined threshold level substantially at the same time during the first time period.

[0128] The first time period may correspond to an analyte sensor life.

[0129] A further aspect may include when the determined rate of change of the received plurality of the time spaced temperature data does not exceed the predetermined thresh-

old level, deactivating a notification function configured to be asserted when the determined rate of change of the analyte related data exceeds the predetermined threshold level.

[0130] The deactivated notification function may include a hypoglycemic alarm.

[0131] In another embodiment, an apparatus may comprise one or more processors, and a memory for storing instructions which, when executed by the one or more processors, causes the one or more processors to monitor a variation in on-skin temperature in proximity to a transcutaneously positioned analyte sensor having at least a portion in fluid contact with an analyte during a monitoring time period, detect the variation in the monitored temperature exceeding a predetermined threshold level, confirm a presence of a medically significant condition when the detected variation in the monitored temperature exceeds the predetermined threshold level, and assert a notification associated with the medically significant condition when it is confirmed, wherein the memory for storing instructions which, when executed by the one or more processors, causes the one or more processors to determine a variation in the monitored analyte level exceeding the predetermined threshold level based on comparing a slope indicative of the change in the monitored analyte level substantially to a slope indicative of the change in the monitored on-skin temperature variation.

[0132] Yet another embodiment may include an apparatus comprising one or more processors, and a memory for storing instructions which, when executed by the one or more processors, causes the one or more processors to detect a concurrent occurrence of a decrease in monitored analyte level and a corresponding decrease in monitored on-skin temperature, confirm a presence of an impending hypoglycemic condition, and assert a notification corresponding to the confirmed impending hypoglycemic condition.

[0133] The decrease in the monitored analyte level may include a decrease exceeding approximately 2 mg/dL/minute.

[0134] The decrease in the monitored on-skin temperature may include a temperature decrease exceeding approximately 2° C./15 minutes.

[0135] The memory for storing instructions which, when executed by the one or more processors, may cause the one or more processors to determine a rate of change of the monitored analyte level during a predetermined time period, determine a rate of change of the monitored on-skin temperature during the predetermined time period, and verify the determined rate of change of the monitored analyte level and the determined rate of change of the monitored on-skin temperature exceeds a predetermined threshold level substantially at the same time.

[0136] In yet another embodiment, an apparatus may comprise one or more processors, and a memory for storing instructions which, when executed by the one or more processors, causes the one or more processors to monitor a directional change in glucose level based on data stream received from an analyte sensor during a monitoring time period, monitor a directional change in a first physiological parameter during the monitoring time period, monitor a directional change in a second physiological parameter during the monitoring time period, detect an initialization of a hypoglycemic alarm based, at least in part, on the directional change of the monitored glucose level, and compare the directional change in one or more of the first or the second physiological param-

eters relative to the directional change in the glucose level prior to the assertion of the hypoglycemic alarm.

[0137] The first physiological parameter or the second physiological parameter may be one of a temperature level, a perspiration level, heart rate, detected tremor, or oxygen saturation level.

[0138] The hypoglycemic alarm may be asserted when the glucose level directional change and the first physiological parameter directional change are the same.

[0139] The alarm may be asserted only when the second physiological parameter directional change is opposite the first physiological parameter directional change.

[0140] The monitored directional change in glucose level may have a negative slope.

[0141] The monitored directional change in the first physiological parameter may have a negative slope, and further, the monitored directional change in the second physiological parameter may have a positive slope.

[0142] The monitoring time period may include approximately five days or seven days.

[0143] The hypoglycemic alarm initialization may be detected when the monitored directional change in glucose level exceeds a predetermined threshold.

[0144] The predetermined threshold may include a decreasing rate of glucose level of approximately 2 mg/dL/minute.

[0145] The memory for storing instructions which, when executed by the one or more processors, may cause the one or more processors to temporarily disable the hypoglycemic alarm initialization based on the comparison.

[0146] The memory for storing instructions which, when executed by the one or more processors, may cause the one or more processors to disable the hypoglycemic alarm initialization when the directional change of the first and second physiological parameters are the same.

[0147] The memory for storing instructions which, when executed by the one or more processors, may cause the one or more processors to disable the hypoglycemic alarm initialization when the directional change of the monitored glucose level does not coincide with the directional change of either of the first and second physiological parameters.

[0148] Various other modifications and alterations in the structure and method of operation of this invention will be apparent to those skilled in the art without departing from the scope and spirit of the invention. Although the invention has been described in connection with specific preferred embodiments, it should be understood that the invention as claimed should not be unduly limited to such specific embodiments. It is intended that the following claims define the scope of the present invention and that structures and methods within the scope of these claims and their equivalents be covered thereby.

What is claimed is:

1. A system, comprising:

an analyte sensor positioned in fluid contact with interstitial fluid under a skin layer and configured to generate signals corresponding to a monitored analyte level in the interstitial fluid;

sensor electronics electrically coupled to the analyte sensor and configured to generate analyte data based on the signals generated by the analyte sensor; and

a data receiver configured to receive the generated analyte data from the sensor electronics, the data receiver configured to trigger a hold assertion function to prevent the

- assertion of a programmed notification when a rate of change of the monitored analyte level determined from the generated analyte data exceeds a predetermined analyte threshold during a monitoring time period, and to assert the programmed notification when the rate of change of a monitored temperature exceeds a predetermined temperature threshold during the monitoring time period.
2. The system of claim 1, wherein the predetermined analyte threshold includes a decreasing rate of the analyte level of approximately 2 mg/dL/minute.
 3. The system of claim 1, wherein the asserted programmed notification indicates a hypoglycemic condition.
 4. The system of claim 1, wherein the data receiver is configured to assert the programmed notification when a direction of the analyte level rate of change and a direction of the monitored temperature rate of change are the same.
 5. The system of claim 1, wherein the monitored analyte level includes one or more of glucose level or lactate level.
 6. The system of claim 1, wherein the data receiver is configured to receive monitored temperature information to determine the rate of change of the monitored temperature.
 7. The system of claim 1, wherein the predetermined temperature threshold includes a decreasing rate of a temperature level of approximately 2° C./15 minutes.
 8. The system of claim 1, wherein the analyte sensor includes a plurality of electrodes including a working electrode comprising an analyte-responsive enzyme bonded to a polymer disposed on the working electrode.
 9. The system of claim 8, wherein the analyte-responsive enzyme is chemically bonded to the polymer disposed on the working electrode.
 10. The system of claim 8, wherein the working electrode comprises a mediator bonded to the polymer disposed on the working electrode.
 11. The system of claim 10, wherein the mediator is crosslinked with the polymer disposed on the working electrode.
 12. The system of claim 1, wherein the analyte sensor includes a plurality of electrodes including a working electrode comprising a mediator bonded to a polymer disposed on the working electrode.
 13. A system, comprising:
 - sensor electronics configured to receive signals from an analyte sensor in fluid contact with interstitial fluid, and to generate analyte data corresponding to a monitored analyte level in interstitial fluid; and
 - a data receiver configured to receive the generated analyte data from the sensor electronics, the data receiver configured to prevent the assertion of a programmed notification when a rate of change of the monitored analyte level determined from the generated analyte data exceeds a predetermined analyte threshold during a monitoring time period, but to assert the programmed notification when a rate of change of the monitored temperature exceeds a predetermined temperature threshold during the monitoring time period.
 14. The system of claim 13, wherein the predetermined analyte threshold includes a decreasing rate of the analyte level of approximately 2 mg/dL/minute.
 15. The system of claim 13, wherein the predetermined temperature threshold includes a decreasing rate of a temperature level of approximately 2° C./15 minutes.
 16. The system of claim 13, wherein the data receiver is configured to assert the programmed notification when the direction of the analyte level rate of change and the direction of the temperature level rate of change are the same.

* * * * *

专利名称(译)	检测假低血糖症状的方法和装置		
公开(公告)号	US20150265192A1	公开(公告)日	2015-09-24
申请号	US14/730077	申请日	2015-06-03
[标]申请(专利权)人(译)	雅培糖尿病护理公司		
申请(专利权)人(译)	雅培糖尿病INC.		
当前申请(专利权)人(译)	雅培糖尿病INC.		
[标]发明人	FELDMAN BENJAMIN JAY HELLER ADAM KIAIE NAMVAR		
发明人	FELDMAN, BENJAMIN JAY HELLER, ADAM KIAIE, NAMVAR		
IPC分类号	A61B5/145 A61B5/1486 A61B5/00 A61B5/01		
CPC分类号	A61B5/14532 A61B5/01 A61B5/746 A61B5/14546 A61B5/14865 A61B5/1451		
优先权	61/256920 2009-10-30 US		
其他公开文献	US10117606		
外部链接	Espacenet USPTO		

摘要(译)

本公开的实施方案包括检测监测的分析物水平的降低的同时发生和监测的皮肤上温度的相应降低，确认即将发生的低血糖状况的存在，并且断言对应于确认的即将发生的低血糖状况的通知。还提供了包含其的装置，方法，系统和套件。

