



US 20140180034A1

(19) **United States**

(12) **Patent Application Publication**
Hoseit et al.

(10) **Pub. No.: US 2014/0180034 A1**

(43) **Pub. Date: Jun. 26, 2014**

(54) **SIMULTANEOUS IMAGING, MONITORING,
AND THERAPY**

Publication Classification

(71) Applicant: **Volcano Corporation**, San Diego, CA (US)

(51) **Int. Cl.**
A61B 5/00 (2006.01)
A61B 8/12 (2006.01)

(72) Inventors: **Paul Hoseit**, El Dorado Hills, CA (US);
Scott Huennekens, San Diego, CA (US)

(52) **U.S. Cl.**
CPC *A61B 5/6847* (2013.01); *A61B 8/12* (2013.01); *A61B 5/0073* (2013.01)

(73) Assignee: **VOLCANO CORPORATION**, San Diego, CA (US)

USPC **600/301**; 600/407; 600/467; 600/425

(21) Appl. No.: **14/134,184**

(57) **ABSTRACT**

(22) Filed: **Dec. 19, 2013**

Using the disclosed intravascular devices it is possible to image tissues, deliver therapy, and evaluate the tissue after the therapy is delivered. One embodiment is a catheter configured to provide ultrasound imaging, drug delivery, and Doppler flow analysis. The devices can use ultrasound imaging as well as optical coherence tomography (OCT).

Related U.S. Application Data

(60) Provisional application No. 61/745,119, filed on Dec. 21, 2012.

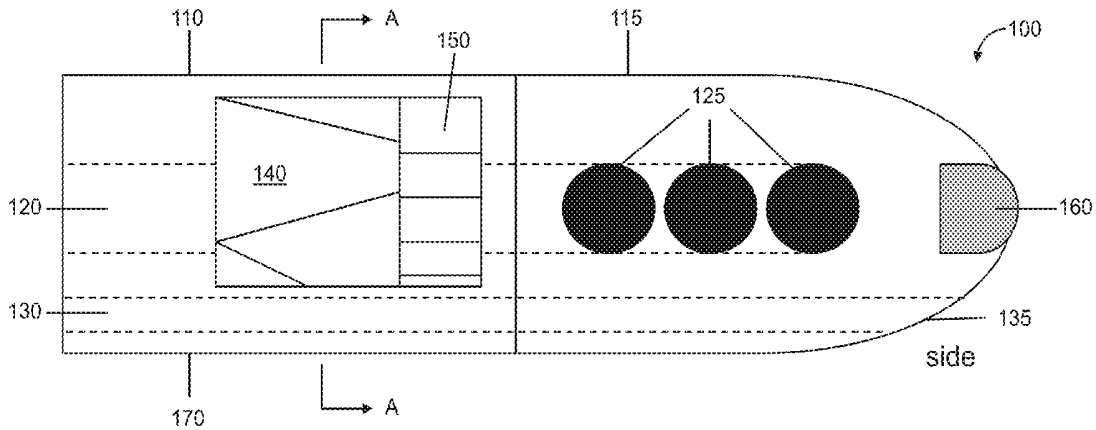

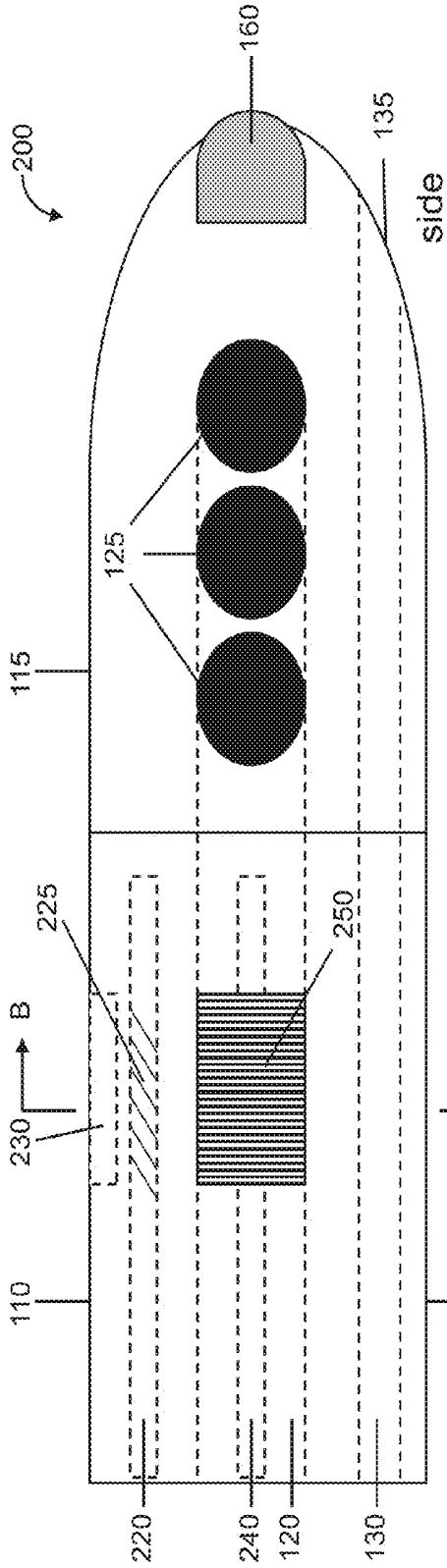

FIG. 2A

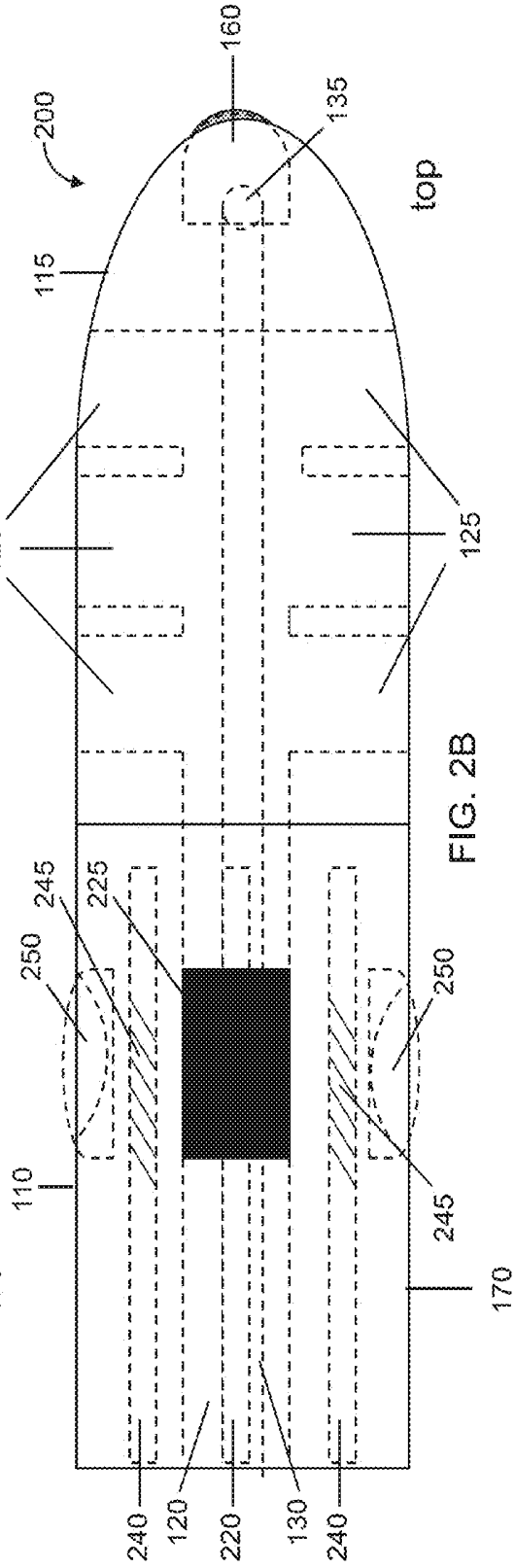
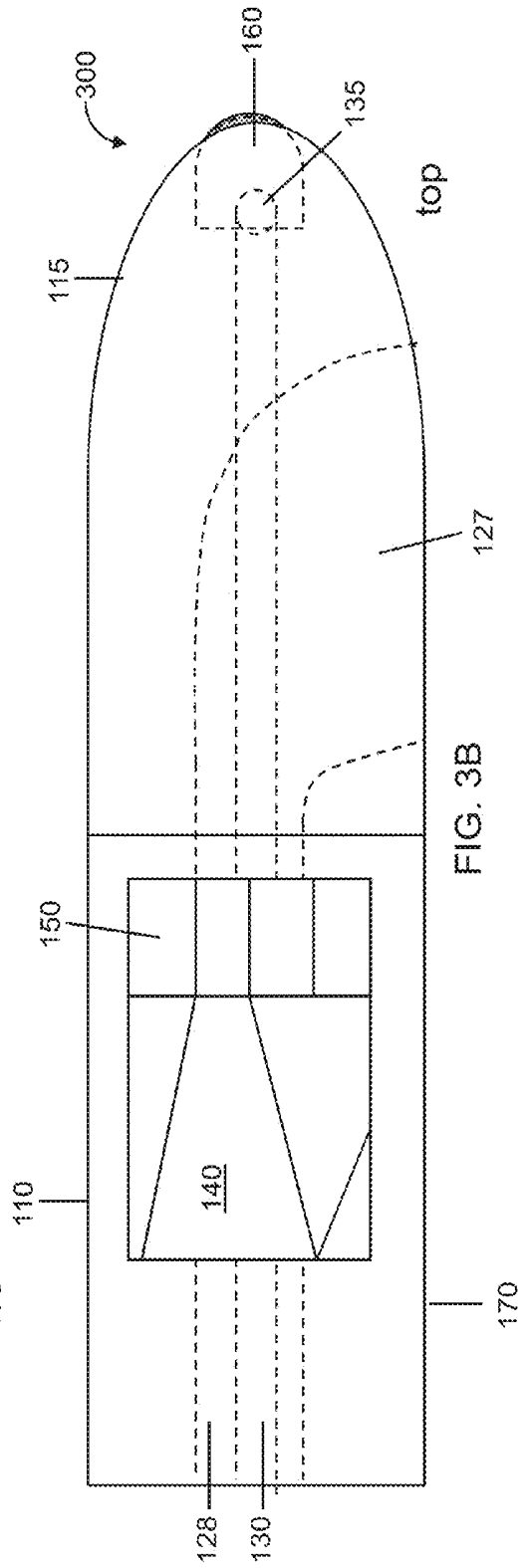
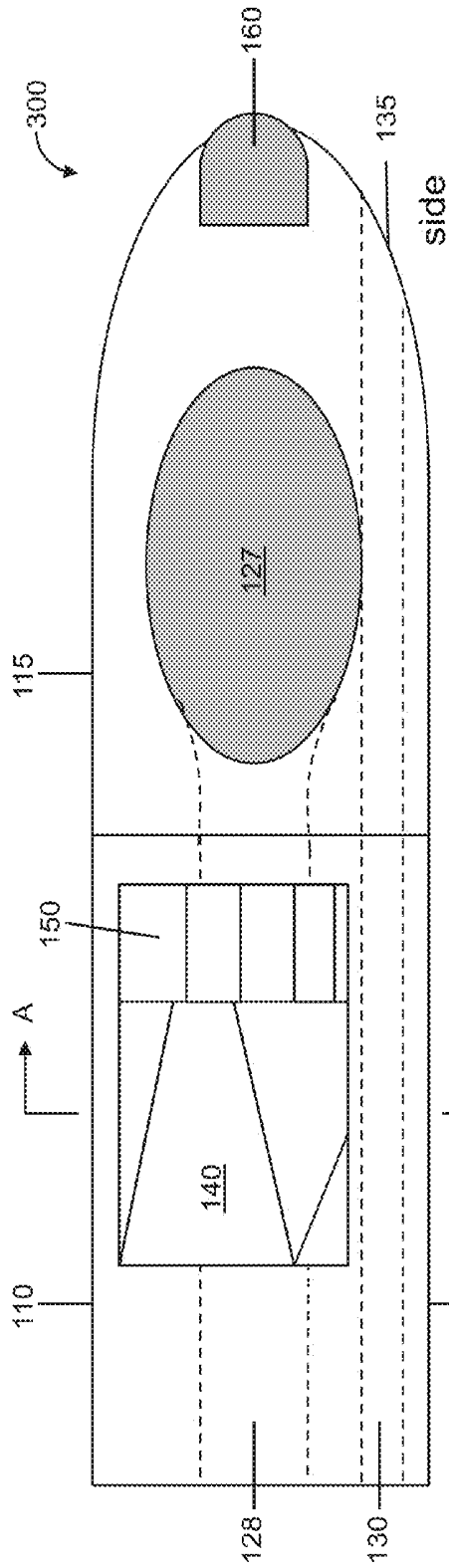

FIG. 2B



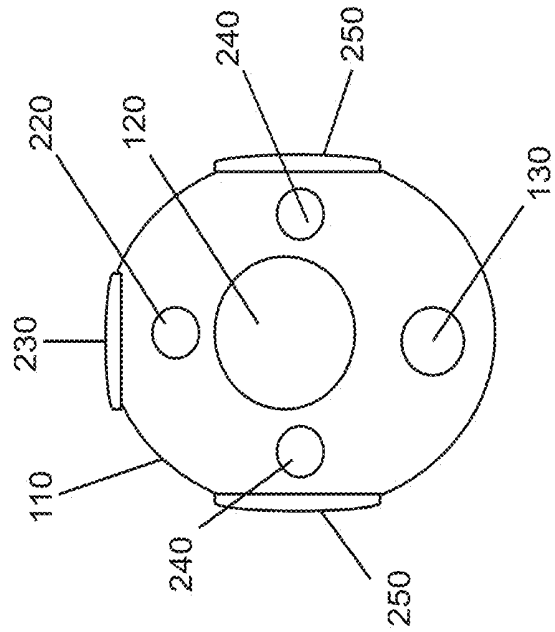

FIG. 4C
detail BB

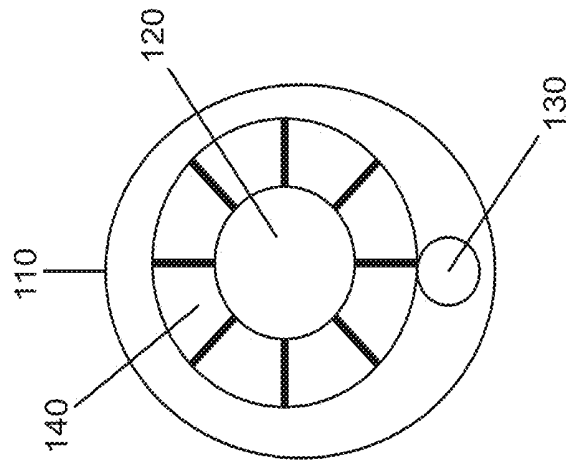

FIG. 4B
detail AA

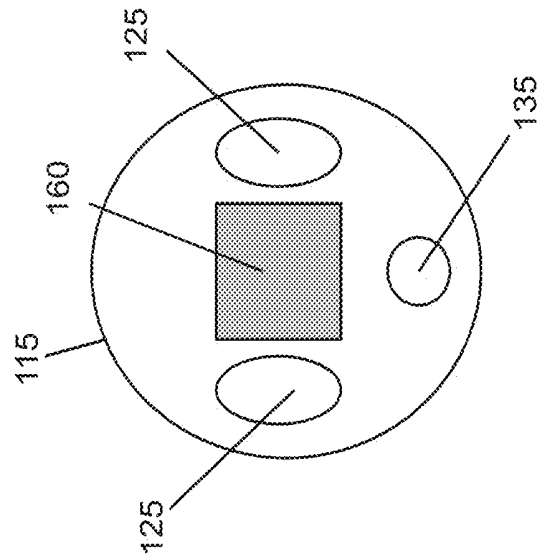

FIG. 4A

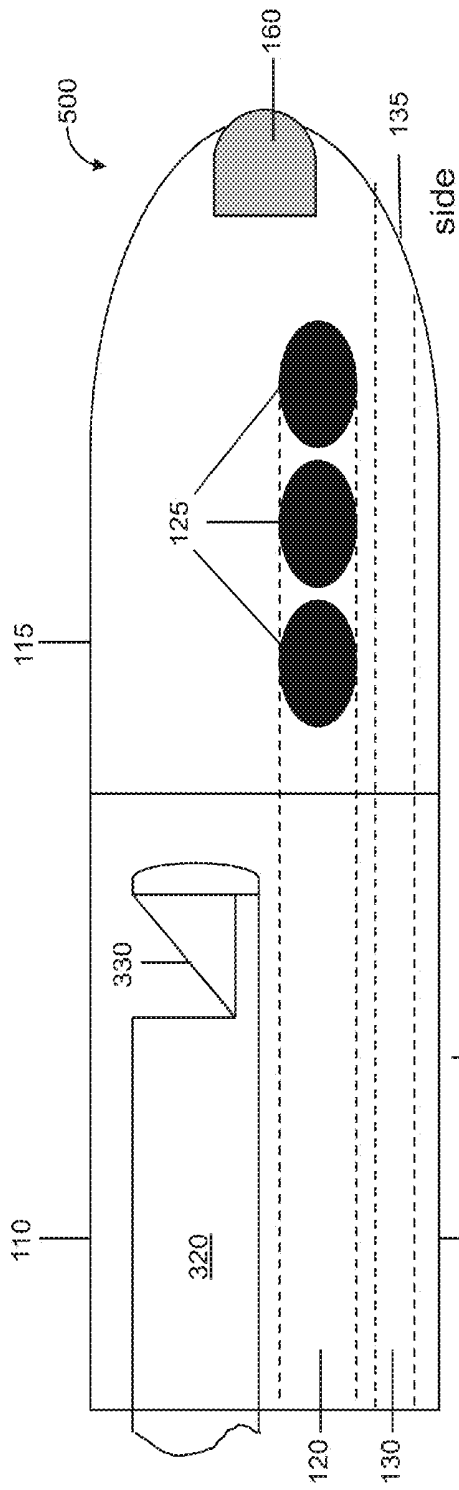

FIG. 5A

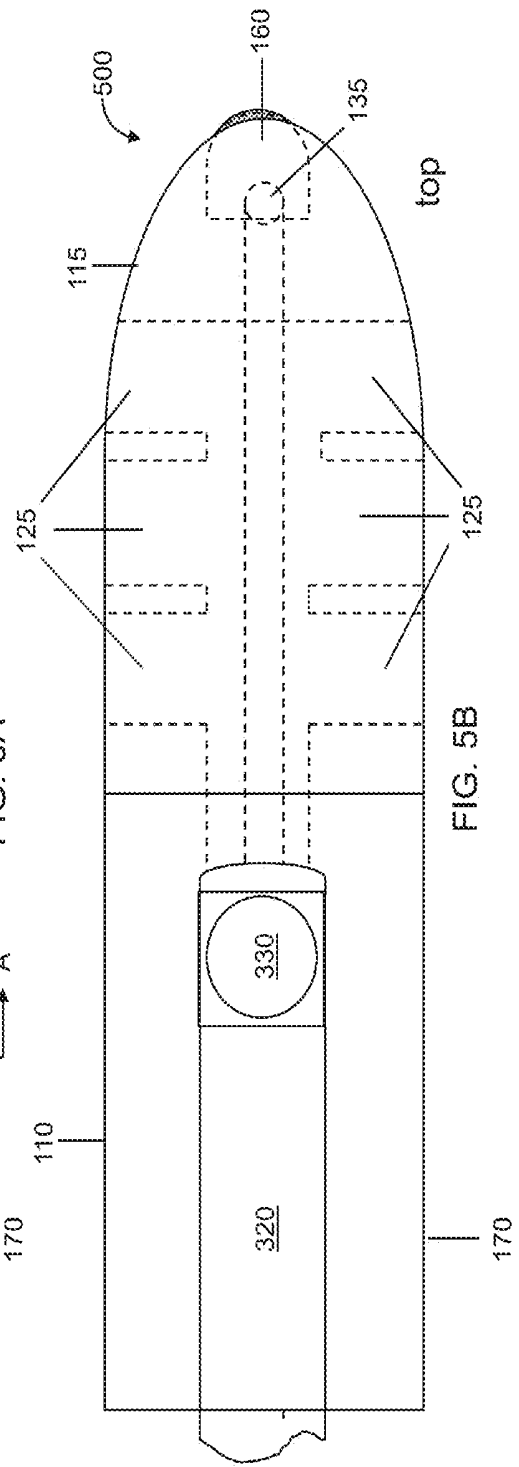

FIG. 5B

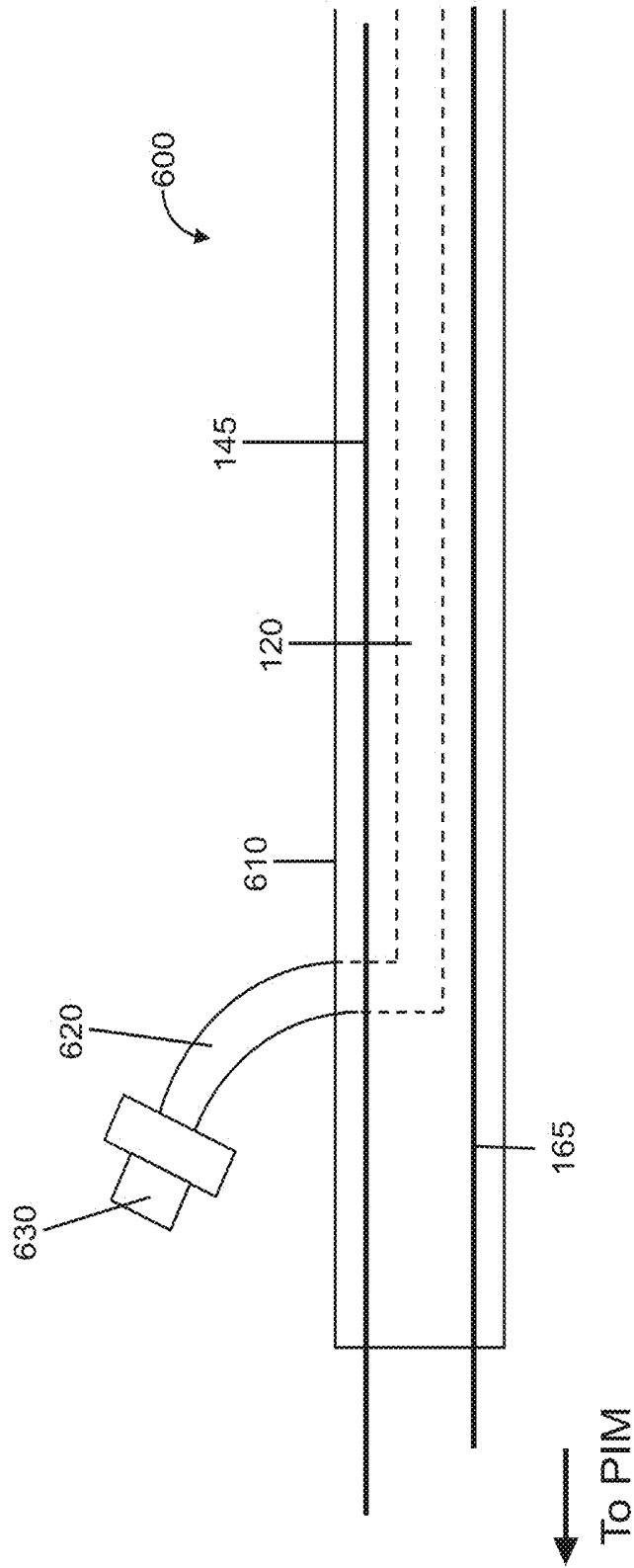

FIG. 6

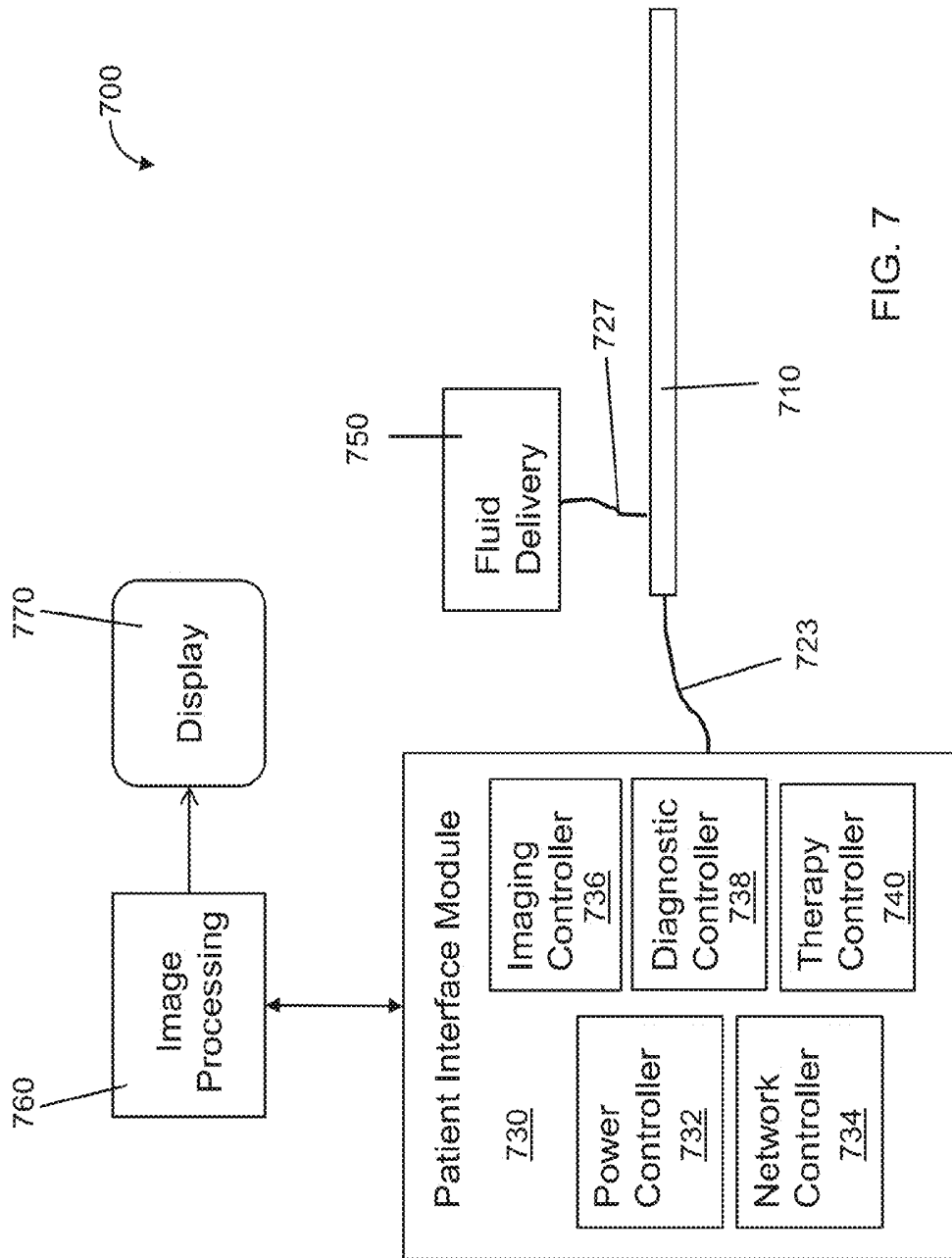

FIG. 7

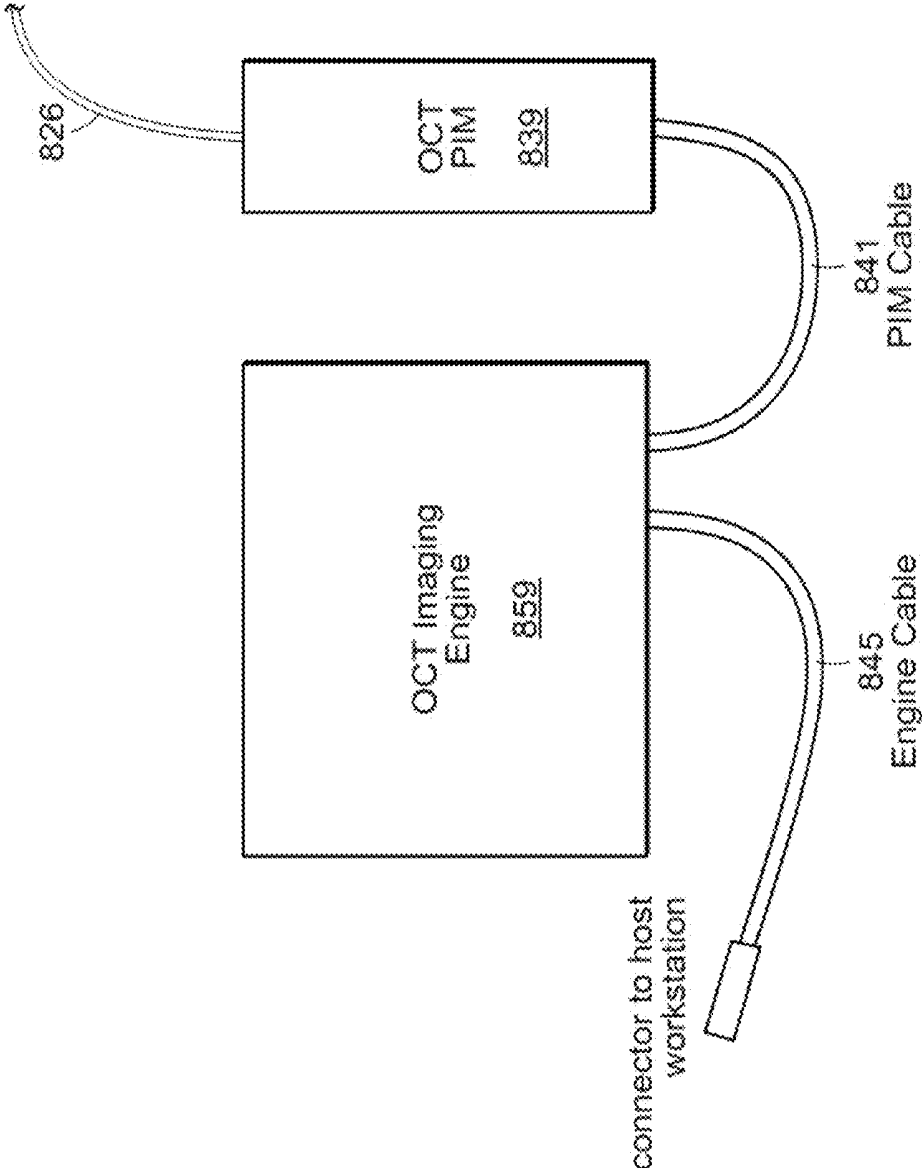

FIG. 8A

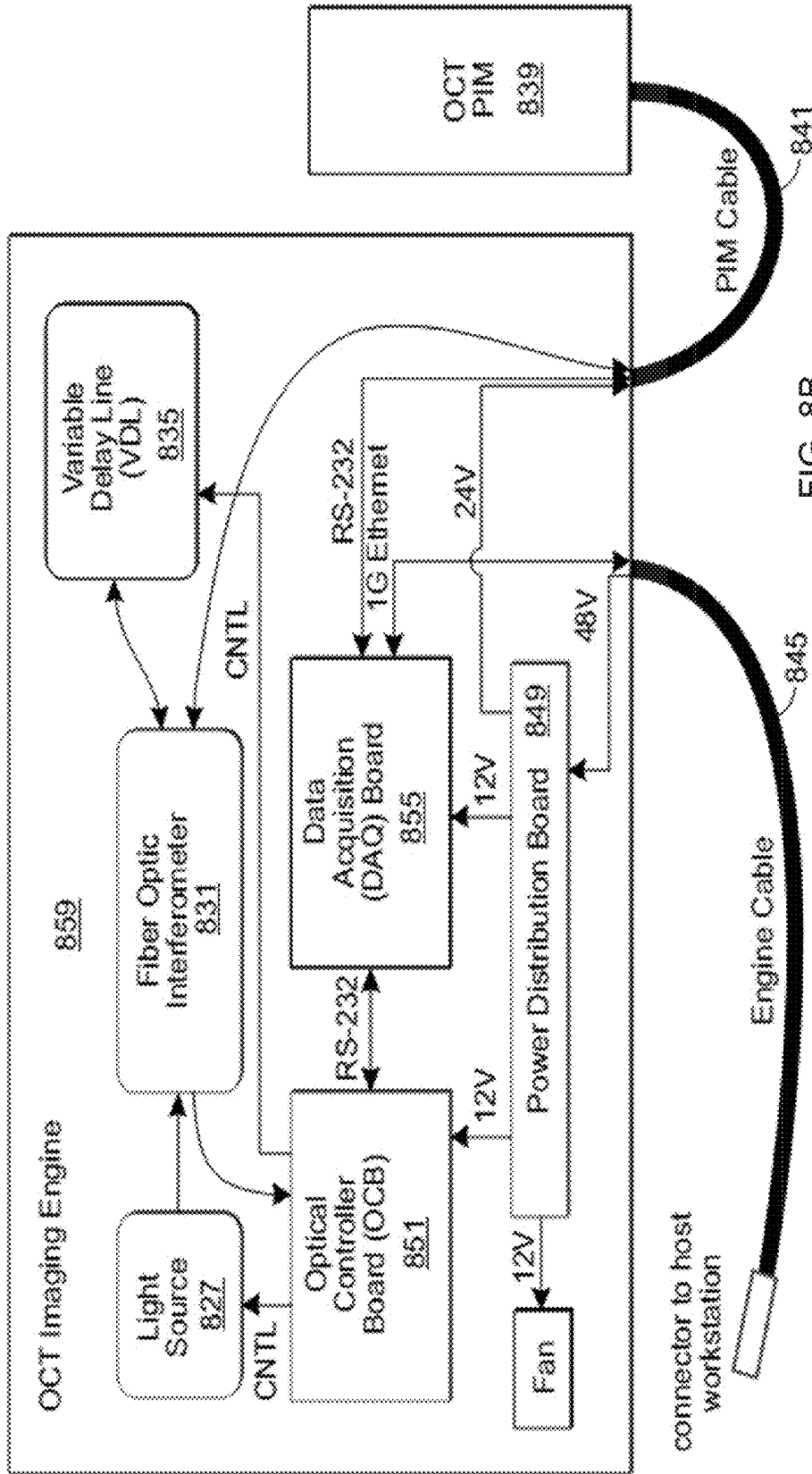

FIG. 8B

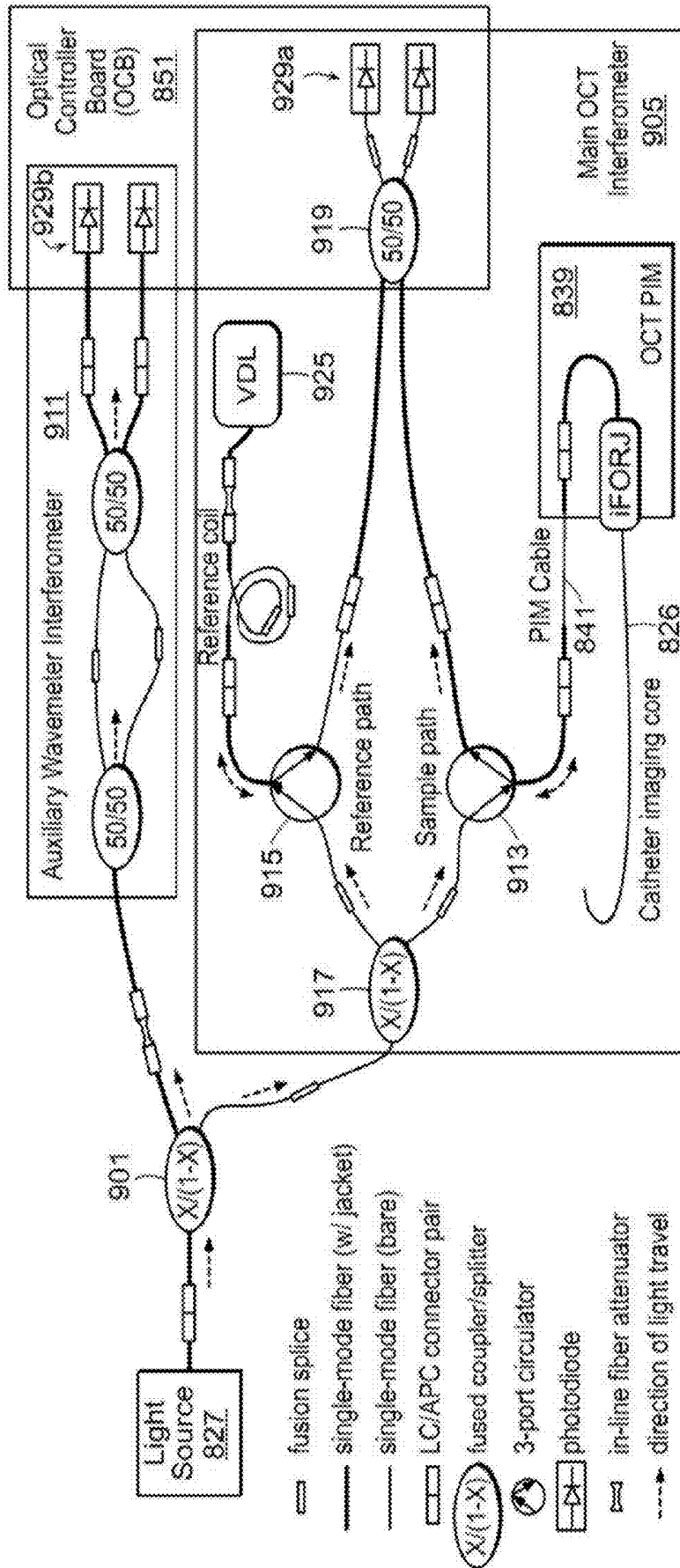

FIG. 9

SIMULTANEOUS IMAGING, MONITORING, AND THERAPY

CROSS-REFERENCE TO RELATED APPLICATIONS

[0001] This application claims the benefit of, and priority to, U.S. Provisional Application Ser. No. 61/745,119, filed Dec. 21, 2012, the contents of which are incorporated by reference herein in its entirety.

FIELD OF THE INVENTION

[0002] The invention relates to medical devices, such as catheters, that can accomplish multiple tasks at a treatment site, such as imaging, therapeutic delivery, and diagnostic measurement.

BACKGROUND

[0003] Endovascular techniques allow a variety of disorders to be evaluated and treated without creating an open surgical field. Such techniques include vascular imaging, aneurism and lesion repair, or even heart valve replacement. Because the techniques are less invasive, they reduce the length of hospital stays associated with treatment, as well as the rate of complications from the treatments. Accordingly, the techniques can reduce costs associated with chronic disease, such as cardiovascular disease.

[0004] With current technology, each procedural step typically requires a separate specialized catheter. For example, a patient having a suspected thrombus (blood clot) in an artery will have a guidewire placed in proximity to the occlusion and then an imaging catheter will be delivered to the location to evaluate the site. In particular, the guidewire may be placed within the artery and the imaging catheter may be inserted into the artery by way of the guidewire and positioned at or near the occlusion site. After evaluation, the site may be re-imaged with angiography to verify the location of the defect. The imaging catheter will then be removed, and a new drug delivery catheter will be delivered on the original guidewire. Once delivered, a thrombolytic agent can be administered via the drug delivery catheter. The drug delivery catheter is then removed, and the imaging catheter is replaced to evaluate the success of the thrombolytic agent. Alternatively, a flow-sensing catheter may be used to evaluate the success of the procedure.

[0005] Procedures requiring multiple catheter exchanges expose patients to a variety of risks. Because multiple components have to be located within the patient, the patient is exposed to substantial amounts of contrast and x-rays. In addition, each catheter exchange increases the risk of a perforated vessel or other mechanical damage. Exchange procedures can also inadvertently dislodge plaque between the entry point and the treatment site. The dislodged plaque may lead to an embolism or other damage away from the site of treatment.

SUMMARY

[0006] The invention facilitates advanced endovascular treatments by providing devices that allow multiple endovascular procedures to be performed with the same device. Because the procedures of the present invention require no, or fewer, catheter exchanges, the procedure can be completed faster than conventional procedures generally requiring mul-

iple exchanges, thereby reducing a patient's exposure to contrast and x-rays, and reducing the cumulative risk of perforation.

[0007] The invention includes catheters that can use various combinations of imaging, treatment, and measurement. The imaging may be intravascular ultrasound (IVUS), optical coherence tomography (OCT), or visible imaging. The treatment may be drug delivery, energy therapy (e.g., light or acoustic), aspiration, ablation, angioplasty, debulking, or implant delivery (stent, filter, valve). The measurement may include flow, pressure, temperature, oxygenation, or spectroscopic measurements to determine the presence of specific chemical species. Because the catheters are multifunctional, it will be possible to evaluate a treatment site, administer a treatment, and then re-evaluate the site to determine the success of the treatment. For example, the invention makes it possible to image an arterial lesion with intravascular ultrasound (IVUS), deliver a thrombolytic agent to the lesion, and then measure blood flow in at or near the lesion site in order to gauge the success of the treatment.

[0008] The invention is not limited to cardiovascular procedures, however, because devices according to the invention generally provide an ability to image tissue(s), deliver one or more therapies to the tissue(s), and evaluate the success of the therapy. For example, devices of the invention can be used to evaluate a site suspected to be cancerous and deliver therapeutics to the tissues simultaneously with the imaging. Using this technique, a physician can easily treat multiple sites because it is not necessary to change catheters between tumors. Furthermore, there is less risk that a tumor site will be missed because the imaging catheter was removed and the drug delivery catheter was not returned to the correct site. Additionally, because the devices of the invention have such a small diameter, disease sites can be reached through other entry points, such as the urethra.

[0009] In one instance, the invention is a device configured to provide acoustic energy to a tissue, receive reflected acoustic energy from the tissue, deliver therapy to the tissue, and measure a property of the tissue, or an environment associated with the tissue. In some embodiments, the device is configured to deliver, for example, a solution comprising a therapeutic agent to a tissue. In some embodiments, the device is configured to image the tissue with intravascular ultrasound (IVUS). Other modes of therapy are additionally available.

[0010] In another instance, the invention is a device configured to image a tissue with optical coherence tomography, deliver a therapy, and measure a property of the tissue, or an environment in proximity to the tissue. The device is configured to deliver, for example, a solution comprising a therapeutic agent to a tissue. Other modes of therapy are additionally available.

[0011] In another instance, the invention is a system for delivering therapeutic agents to a subject, including a guidewire having an ultrasound transducer, configured to image, monitor, or deliver acoustic therapy to a tissue. The system also includes a catheter having a first lumen in fluid communication with a proximal end and a distal end of the catheter, a second lumen for receiving the guidewire located in proximity to the distal end of the catheter, an ultrasound transducer in communication with a connector located in proximity to the proximal end of the catheter, and an ultrasound receiver in communication with the connector. In some embodiments, the guidewire includes an optical fiber.

[0012] In another instance, the invention is a device for delivering therapy to a subject. The device includes a first lumen in fluid communication with a proximal end and a distal end of the device, a second lumen for receiving a guidewire located in proximity to the distal end of the device, an ultrasound transducer in communication with a connector located in proximity to the proximal end of the device, and an ultrasound receiver in communication with the connector. The ultrasound transducer and receiver may each include a piezoelectric element in electrical communication with the connector. The ultrasound transducer may further include a photoacoustic member in optical communication with the connector. The ultrasound receiver may include a photoreflective member in optical communication with the connector. The ultrasound transducer may be configured to produce acoustic energy with a frequency between 15 and 30 MHz and/or between 5 and 15 MHz and/or between 100 kHz and 5 MHz. Further, the ultrasound transducer may be located at a distal tip of the device. The ultrasound transducer may be a pulsed ultrasound transducer.

[0013] The device may further include an optical fiber in optical communication with the proximal end and the distal end of the device. The optical fiber may include a blazed Bragg grating. The device may further include a lens located in proximity to the distal end of the device and in optical communication with the optical fiber.

[0014] In some embodiments, the first lumen of the device can be used to deliver a therapeutic agent. For example, the first lumen can be used to aspirate a tissue, to inflate a balloon at the distal end of the device, or combinations thereof. The device may further include a port in fluid communication with the proximal end of the first lumen. Further, in some embodiments, the second lumen may be less than 100 mm in length. In some embodiments, the device can be delivered through an introducer having an opening of 12 French or less (4 mm or smaller). Further, the device may include a radiopaque label. In some embodiments, the device may be a catheter.

[0015] In another instance, the invention is a system for delivering therapy to a subject. The system includes a guidewire including a guidewire ultrasound transducer in communication with a guidewire connector located at the proximal end of the guidewire. The system further includes a catheter including a first lumen in fluid communication with a proximal end and a distal end of the catheter, a second lumen for receiving the guidewire located in proximity to the distal end of the catheter, a plurality of catheter ultrasound transducers in communication with a connector located in proximity to the proximal end of the catheter, and a plurality of catheter ultrasound receivers in communication with the connector.

[0016] In some embodiments, the guidewire additionally includes a guidewire ultrasound receiver in communication with the guidewire connector. In some embodiments, at least one of the guidewire ultrasound transducers and receivers may include a piezoelectric element in electrical communication with the guidewire connector. In some embodiments, at least one of the guidewire ultrasound transducers and receivers may each include a photoacoustic member in optical communication with the guidewire connector. In some embodiments, at least one of the guidewire ultrasound transducers and receivers may each include a photoreflective member in optical communication with the guidewire connector. In some embodiments, at least one of the catheter ultrasound transducers and receivers may include piezoelec-

tric elements in electrical communication with the catheter connector. In some embodiments, the catheter ultrasound transducers may include photoacoustic members in optical communication with the catheter connector. In some embodiments, the catheter ultrasound receivers may include photoreflective members in optical communication with the catheter connector. Further, in some embodiments, the guidewire includes at least one of an optical fiber and a lens.

[0017] In another instance, the invention is a system for delivering therapy to a subject. The system includes a guidewire including a guidewire ultrasound transducer in communication with a guidewire connector located at the proximal end of the guidewire. The system further includes a catheter including a first lumen in fluid communication with a proximal end and a distal end of the catheter, a second lumen for receiving the guidewire located in proximity to the distal end of the catheter, and a rotational imaging element.

[0018] The invention also provides methods for treating tissues, including imaging a tissue with acoustic energy from a device, administering therapy to the tissue with the device, and measuring a property of an environment associated with the tissue with the device. The imaging includes at least one of IVUS and OCT methods. The administering of therapy to the tissue may include delivering a solution including a therapeutic agent and further administering electromagnetic radiation to the therapeutic agent. The administering of therapy may also, or alternatively, include placing a medical device selected from a strut, stent, valve, or filter.

[0019] The property may include blood flow in a vessel, blood pressure in a vessel, blood oxygenation in a vessel, temperature, presence of a chemical species, or a combination thereof. The measuring may include making a spectroscopic measurement selected from infrared absorption, visible absorption, Raman, fluorescence, or combinations thereof. The therapy may also, or alternatively, include aspirating a tissue, angioplasty, and/or ablation.

[0020] The invention also provides methods for treating tissues, including imaging a tissue with acoustic energy from a device, administering therapy to the tissue with the device, and administering acoustic therapy to the tissue with the device. The method also includes measuring a property of the tissue or an environment associated with the tissue with the device. The imaging includes at least one of IVUS and OCT methods. The administering of therapy to the tissue may include delivering a solution including a therapeutic agent and further administering electromagnetic radiation to the therapeutic agent. The administering of therapy may also, or alternatively, include placing a medical device selected from a strut, stent, valve, or filter.

[0021] The property may include blood flow in a vessel, blood pressure in a vessel, blood oxygenation in a vessel, temperature, presence of a chemical species, or a combination thereof. The measuring may include making a spectroscopic measurement selected from infrared absorption, visible absorption, Raman, fluorescence, or combinations thereof. The therapy may also, or alternatively, include aspirating a tissue, angioplasty, and/or ablation.

[0022] These and other aspects, advantages, and features of the invention will be better understood with reference to the following drawings and description.

BRIEF DESCRIPTION OF THE DRAWINGS

[0023] FIG. 1A depicts a side view of the distal end of a catheter of the invention;

[0024] FIG. 1B depicts a top view of the distal end of a catheter of the invention;

[0025] FIG. 2A depicts a side view of the distal end of a catheter of the invention;

[0026] FIG. 2B depicts a top view of the distal end of a catheter of the invention;

[0027] FIG. 3A depicts a side view of the distal end of a catheter of the invention;

[0028] FIG. 3B depicts a top view of the distal end of a catheter of the invention;

[0029] FIG. 4A depicts a distal end view of a catheter of the invention;

[0030] FIG. 4B depicts a cross-sectional view of the catheter of FIGS. 1A and 1B;

[0031] FIG. 4C depicts a cross-sectional view of the catheter of FIGS. 2A and 2B;

[0032] FIG. 5A depicts a side view of the distal end of a catheter of the invention;

[0033] FIG. 5B depicts a top view of the distal end of a catheter of the invention;

[0034] FIG. 6 depicts the proximal end of a catheter of the invention;

[0035] FIG. 7 depicts a system including a catheter of the invention;

[0036] FIG. 8A is a diagram of components of an optical coherence tomography (OCT) subsystem;

[0037] FIG. 8B is a diagram of the imaging engine shown in FIG. 8B;

[0038] FIG. 9 is a diagram of a light path in an OCT system of certain embodiments of the invention.

DETAILED DESCRIPTION

[0039] The invention provides advanced intraluminal devices configured to image tissues, deliver therapy to the tissues, and monitor the results of the therapy on an environment in proximity to the tissue. The devices allow a variety of treatments to be administered with the devices, including, but not limited to drug delivery, energy therapy (e.g., light or acoustic), aspiration, ablation, angioplasty, debulking, or implant delivery (stent, filter, valve). For example, the invention includes drug delivery catheters that are configured to provide IVUS imaging and Doppler flow monitoring. The devices of the invention may use “conventional” IVUS components, such as piezoelectric transducers, or the devices may use optical IVUS components, described in detail below. The devices may use optical coherence tomography (OCT). The devices lend themselves to methods for the treatment of tissues in need thereof as well as systems including the devices of the invention.

[0040] Using the devices of the invention, a variety of target tissues can be imaged, diagnosed, treated, and evaluated with the devices, methods, and systems of the invention. In particular the invention is useful for treating tissues that are accessible via the various lumens of the body, including, but not limited to, blood vessels, vasculature of the lymphatic and nervous systems, structures of the gastrointestinal tract (lumens of the small intestine, large intestine, stomach, esophagus, colon, pancreatic duct, bile duct, hepatic duct), lumens of the reproductive tract (vas deferens, uterus and fallopian tubes), structures of the urinary tract (urinary collecting ducts, renal tubules, ureter, and bladder), and structures of the head and neck and pulmonary system (sinuses, parotid, trachea, bronchi, and lungs). Accordingly, the devices, methods, and systems of the invention may be beneficial in the treat-

ment of a number of disorders, including, but not limited to, atherosclerosis, ischemia, coronary blockages, thrombi, occlusions, stenosis, and aneurysms. The devices, methods, and systems can also be used to treat cancer, inflammatory disease (e.g., autoimmune disease, arthritis), pain, and genetic disorders.

[0041] The devices, methods, and systems of the invention can be used to administer a variety of therapeutics, such as thrombolytic agents, anti-cancer agents, anti-inflammatory agents, analgesic agents, or combinations thereof. For example, the therapeutic agent may comprise streptokinases, anistreplases, urokinases, tissue plasminogen activators (t-PA), alteplases, tenecteplases, or reteplases. The devices, methods, and systems of the invention may be used to administer more than one therapeutic or more than one class of therapeutics. For example, a solution delivered to a tissue in need of treatment may comprise a thrombolytic drug and an anti-coagulant, such as heparin.

[0042] The devices, methods, and systems of the invention can be used to administer therapy with a catheter. The devices can be used for angioplasty, such as balloon angioplasty. The devices can be used for ablation, such as balloon ablation, or probe ablation. The devices can be used to aspirate or remove tissues. The devices can be used for medical device placement, such as stents, struts, valves, filters, pacemakers, or radiomarkers. The devices, methods, and systems of the invention may be used to administer more than one therapy of combinations of therapies and therapeutics, e.g., drugs. For example, a solution delivered to a tissue in need of treatment may comprise a thrombolytic drug and aspiration.

[0043] Devices of the invention are typically catheters. A variety of intravascular catheters are known. In practice, intravascular catheters are delivered to a tissue of interest via an introducer sheath placed in the radial, brachial or femoral artery. The introducer is inserted into the artery with a large needle, and after the needle is removed, the introducer provides access for guidewires, catheters, and other endovascular tools. An experienced cardiologist can perform a variety of procedures through the introducer by inserting tools such as balloon catheters, stents, or cauterization instruments. When the procedure is complete the introducer is removed, and the wound can be secured with suture tape. Catheter lengths vary up to 400 cm, depending on the anatomy and work flow. The ends of the catheter are denoted as distal (far from the user, i.e., inside the body) and proximal (near the user, i.e., outside the body).

[0044] An important function of the devices is an ability to image a tissue prior to treatment. In particular, the invention provides devices, systems and methods for imaging tissue using intravascular ultrasound (IVUS). IVUS uses a catheter with an ultrasound probe attached at the distal end. Systems for IVUS are also discussed in U.S. Pat. No. 5,771,895, U.S. Pat. Pub. 2009/0284332, U.S. Pat. Pub. 2009/0195514 A1, U.S. Pat. Pub. 2007/0232933, and U.S. Pat. Pub. 2005/0249391, the entire contents of each of which are incorporated herein by reference.

[0045] In some embodiments, the devices are configured to image tissues with optical coherence tomography (OCT), which uses interferometric measurements to determine radial distances and tissue compositions. Systems for OCT imaging are discussed in U.S. Pat. No. 7,813,609 and US Patent Publication No. 20090043191, both of which are incorporated herein by reference in their entireties.

[0046] The disclosed devices are commonly used in conjunction with guidewires. Guidewires are known medical devices used in the vasculature or other passageway and act as a guide for other devices, e.g., a catheter. Typically, the guidewire is inserted into an artery or vein and guided through the vasculature under fluoroscopy (real time x-ray imaging) to the location of interest. (As discussed previously, some procedures require one or more catheters to be delivered over the guide wire to diagnose, image, or treat the condition.) Guidewires typically have diameters of 0.010" to 0.035", with 0.014" being the most common. Guidewires (and other intravascular objects) are also sized in units of French, each French being 1/3 of a mm or 0.013". Guidewire lengths vary up to 400 cm, depending on the anatomy and work flow. Often a guidewire has a flexible distal tip portion about 3 cm long and a slightly less flexible portion about 30 to 50 cm long leading up to the tip with the remainder of the guidewire being stiffer to assist in maneuvering the guidewire through tortuous vasculature, etc. The tip of a guidewire typically has a stop or a hook to prevent a guided device, e.g., a catheter from passing beyond the distal tip. In some embodiments, the tip can be deformed by a user to produce a desired shape.

[0047] Advanced guidewire designs include sensors that measure flow and pressure, among other things. For example, the FLOWIRE Doppler Guide Wire, available from Volcano Corp. (San Diego, Calif.), has a tip-mounted ultrasound transducer and can be used in all blood vessels, including both coronary and peripheral vessels, to measure blood flow velocities during diagnostic angiography and/or interventional procedures. Advanced guidewires, such as FLOWIRE, can be used with the described inventions. In some instances, an advanced guidewire can be used to supplement the capabilities of the devices of the invention. In some instances, an advanced guidewire can be used to replace a capability (e.g., flow sensing) of a disclosed device. In some instances, an advanced guidewire is incorporated into a system of the invention, e.g., additionally including a catheter described below.

[0048] The distal end 110 of a device of the invention (i.e., a catheter) is shown in FIGS. 1A and 1B. FIG. 1A shows a side view of an imaging/delivery/evaluation catheter 100 that uses piezoelectric elements as ultrasound transducers 140 and ultrasound receivers 150 to produce and receive ultrasound energy for imaging. Catheter 100 includes a proximal end (not shown), a mid-body (not shown), and a distal end 110 including a distal tip 115. The distal end 110 includes drug delivery lumen 120 connected to drug delivery ports 125, and guidewire lumen 130 terminating in guidewire exit 135. The distal tip 115 comprises Doppler sensor 160. The entire distal end 110 is coated with a lubricious coating 170, and a suitable ultrasound transparent material is used to cover the ultrasound transducers 140 and ultrasound receivers 150. (The dashed lines indicate that the actual structures are hidden from view in a side or top view of the exterior.)

[0049] The ultrasound transducers 140 are constructed from piezoelectric components that produce sound energy at 20-50 MHz. The ultrasound transducers 140 are known in the field of intravascular ultrasound imaging, and are commercially available from suppliers such as Blatek, Inc. (State College, Pa.). As shown in FIGS. 1A and 1B, the ultrasound transducers 140 are configured in a phased array, that is, each ultrasound receiver 150 is a separate piezoelectric element that produces ultrasound energy. Similarly, each ultrasound receiver 150 is an independent element configured to receive

ultrasound energy reflected from the tissues to be imaged. Alternative embodiments of the ultrasound transducers 140 and the ultrasound receivers 150 may use the same piezoelectric components to produce and receive the ultrasonic energy, for example, by using pulsed ultrasound. Another alternative embodiment may incorporate ultrasound absorbing materials and/or ultrasound lenses to increase signal to noise. Both the ultrasound transducers 140 and the ultrasound receivers 150 have electrical connectors (not shown) that extend from the transducers 140 and receivers 150 to the proximal end of the device to provide power, and to provide and receive ultrasound signals.

[0050] As can be seen more clearly in FIG. 1B, the transducers 140 and receivers 150 are coaxially located with the drug delivery lumen 120 to maximize the inside diameter of the drug delivery lumen 120 with respect to the diameter of the distal end 110 of the device. This detail can also be seen in FIG. 4B, which depicts a cross section from A to A in FIG. 1A. Other embodiments of the invention need not adopt this design. For example drug delivery lumen may run to one side of the ultrasound transducers 140 and receivers 150. Alternatively, drug delivery lumen 120 may comprise multiple lumens that are arranged about the ultrasound transducers 140 and receivers 150 to provide adequate throughput for the delivery of therapeutic agents, typically formulated as a liquid. Additionally, while the views of FIGS. 1A and 1B depict six drug delivery ports 125, this number is arbitrary. The drug delivery lumen 120 merely needs one or more exit ports to allow the therapeutic to be delivered external to the distal end 110.

[0051] The Doppler sensor 160, located in the distal tip 115 of the device allows a physician to measure and observe a property of an environment associated with the tissue being imaged and treated. For example, in one embodiment, the tissue being imaged and treated may be an arterial lesion. Accordingly, the Doppler sensor 160 may be configured to measure a property (e.g., blood flow) of an environment associated with the lesion. As generally understood, an environment associated with the lesion may refer any environment that is connected, either directly or indirectly, to the lesion or sharing a common pathway (e.g., artery) with the lesion. For example, the environment may include one or more portions of the lumen of the artery in which the lesion has formed. The one or more portions may include a portion of the lumen adjacent to the lesion or a portion that is located a distance away from the lesion, either downstream or upstream, along a length of the artery. Accordingly, the Doppler sensor 160 can be inserted within the lumen of the artery and positioned at a location of the lumen associated with the lesion, so as to acquire measurements of blood flow in order to gauge the success of treatment to the lesion. For example, the Doppler sensor 160 may be positioned within a portion of the lumen directly adjacent to the lesion and may acquire blood flow data of the artery. In other examples, the Doppler sensor 160 can be positioned in other portions of the lumen (e.g., downstream and a distance away from the lesion, upstream and a distance away from the lesion, locations therebetween, etc.).

[0052] The Doppler sensor is electrically connected (not shown) to the proximal end of the device, which provides power for the sensor and a return path for recovering measurements. Typically, the sensor produces ultrasound in the range of 5 to 15 MHz, e.g., about 12 MHz. In other embodiments, the Doppler sensor may be replaced with an acoustic therapy transducer (not shown) to deliver acoustic waves to a

tissue being treated. Acoustic therapy transducers typically operate in the range of 100 kHz and 5 MHz. Because the Doppler sensor and the acoustic therapy transducers are rather small, it is also possible for a device to include both a Doppler sensor and an acoustic therapy transducer.

[0053] Other sensors can also be accommodated in distal end 110 and are configured to measure one or more properties of an environment associated with the tissue being imaged and treated, as described herein. For example, the distal end 110 may include a thermocouple, a thermistor, or a temperature diode to measure the temperature of the surroundings associated with the tissue. The distal end 110 may include a pressure sensor, such as a piezoelectric pressure sensor, or a semiconductor pressure sensor. The distal end 110 may also include one or more elements to perform spectroscopic measurements, e.g., infrared absorption spectroscopy, visible wavelength absorption spectroscopy, fluorescence spectroscopy, or Raman spectroscopy. In some embodiments, the spectroscopic measurement will rely on collecting back-scattered or fluorescent light. In some embodiments, the spectroscopic measurements can be made with optical elements that are also used to make OCT measurements. In some embodiments, the distal end 110 of the catheter will include an optical pathway which is in fluid communication with the surroundings of the catheter, thereby allowing direct absorption measurements, for example, visible absorbance spectroscopy.

[0054] Using spectroscopic methods, it is possible to probe a tissue, or the environment around the tissue, for the presence of specific chemical species indicative of the health of the tissue (or the surroundings) or indicative of the efficacy of an administered treatment. The chemical species may include, for example, calcium ions or sodium ions. The methods may also be used to monitor oxygen content of the blood or to determine a level of hemoglobin, for example. In some instances, a dye, i.e., an intercalating dye, can be used in conjunction with the spectroscopic methods to determine the presence of free nucleic acids.

[0055] A different embodiment of the imaging/delivery/evaluation catheter 200 is shown in FIGS. 2A and 2B. FIG. 2A shows a side view of an imaging/delivery/evaluation catheter 200 that uses photoacoustic members 230 as ultrasound transducers and photoreflexive members 250 as ultrasound receivers for imaging. The photoacoustic member 230 is coupled to a source optical fiber 220 with blazed Bragg grating 225 (discussed below). The photoreflexive member 250 is coupled to a return optical fiber 240 with blazed Bragg grating 245. Catheter 200 includes a proximal end (not shown), a mid-body (not shown), and a distal end 110 including a distal tip 115. The distal end 110 includes drug delivery lumen 120 connected to drug delivery ports 125, and guidewire lumen 130 terminating in guidewire exit 135. The distal tip 115 comprises Doppler sensor 160. The entire distal tip 110 is coated with a lubricious coating 170. The photoacoustic members 230 and photoreflexive members 250 are directly in communication with the exterior of the catheter 200.

[0056] The catheter 200 employs fiber Bragg gratings (225 and 245) to couple light into or out of source and return optical fibers 220 and 240. A fiber Bragg grating is a periodic modulation of the index of refraction in a fiber. When the periodicity, d , of the modulation satisfies the Bragg condition ($d=n\lambda/2$) for a wavelength λ , that wavelength will be reflected. That is, the fiber Bragg grating acts as a wavelength-selective mirror. The degree of index change and the length of

the grating influences the ratio of light reflected to that transmitted through the grating. A review of fiber Bragg gratings, including blazed Bragg gratings can be found at A. Othonos, *Rev. Sci. Inst.*, 68 (12), 4309 (1997), incorporated by reference herein in its entirety.

[0057] As shown in FIG. 2A, the blazed Bragg grating 225 couples light from the source optical fiber 220 out of the fiber and into the photoacoustic member 230, whereupon the photoacoustic member 230 produces acoustic energy, i.e., it acts as an ultrasound transducer. This same technique can be used to produce acoustic waves for Doppler measurements, e.g., at Doppler sensor 160.

[0058] In one embodiment, the photoacoustic member 230 has a thickness in the direction of propagation that increases the efficiency of emission of acoustic energy. In some embodiments, the thickness of the photoacoustic material is selected to be about one fourth of the acoustic wavelength of the material at the desired acoustic frequency ("quarter wave matching"). Providing photoacoustic material with quarter wave matching improves the generation of acoustic energy by the photoacoustic material, resulting in improved ultrasound images. Using the quarter wave matching and sensor shaping techniques, the productivity of the fiber blazed Bragg 225 and photoacoustic member 230 approaches the productivity of piezoelectric transducers known in the field of ultrasound imaging.

[0059] In preferred embodiments, the incident light in source optical fiber 220 is pulsed at a frequency at which the acoustic waves will be produced. Light sources that produce pulses at ultrasonic frequencies, e.g., 1 MHz and greater, are commercially-available, typically solid state lasers. Nonetheless, photoacoustic materials have natural acoustic resonances, and the photoacoustic material will naturally produce a spectrum of acoustic frequencies when the material absorbs the incident light, and the photoacoustic material relaxes by producing acoustic waves. If it is desired to rely on the natural frequencies of the photoacoustic material, the incident light in source optical fiber 220 may be continuous.

[0060] The acoustic waves generated by the photoacoustic member 230 interact with tissues (vasculature) in the vicinity of the distal end 110 of the catheter 200, and are reflected back (echoes). The reflected acoustic waves are collected and analyzed to obtain information about the distance from the tissues to the catheter 200, or the type of tissue, or other information, such as blood flow or pressure. The return acoustic energy can also be monitored using light via coupled optical fibers as shown in detail in FIG. 2B, where the photoreflexive material 250 is in communication with the return optical fiber 240 via blazed Bragg grating 245.

[0061] The photoreflexive member 250 is flexibly resilient, and is displaced by acoustic waves reflected by the tissues. A transparent (or translucent) flexible material is disposed between the return optical fiber 240 and the photoreflexive member 250, thereby allowing a deflection in the photoreflexive member 250 to change the path length of the light between the return optical fiber 240 and the photoreflexive member 250. In alternative embodiments, a void can be left between the return optical fiber 240 and the photoreflexive member 250. The dashed curved line in the photoreflexive members 250 in FIG. 2B is intended to show the extent of possible deflection of the photoreflexive material, e.g., with absorption of acoustic energy.

[0062] In the absence of incident acoustic energy, the photoreflexive material will be in a neutral position, providing a

baseline path length between the return optical fiber 240 and the photoreflective member 250. Incident light, transmitted via the return optical fiber 240, will be reflected from the photoreflective member 250, and return to a detector at the proximal end of the catheter 200 (not shown) with a characteristic round trip time. The light transmitted via the return optical fiber 240 may be the same light as used to produce acoustic energy (discussed above) or a different light (wavelength, pulse frequency, etc.) may be used. When the photoreflective member 250 is deflected, i.e., with the absorbance of incident acoustic waves, the path length between the return optical fiber 240 and the photoreflective member 250 will change, resulting in a measurable change in the properties of the reflected light, as measured by a detector at the proximal end of catheter 200 (not shown). The change may be a shift in the time of the return trip, or the shift may be an interferometric measurement. The change in the properties of the reflected light can then be analyzed to determine properties of the tissues from which the acoustic waves were reflected.

[0063] The catheter 200 can be fabricated with various techniques. In an embodiment, the catheter 200 is assembled, such as by binding the optical fibers 220 and 240 to the device and adding coating 170. The photoacoustic member 230 is then integrated into the device 200 by etching or grinding a groove in the assembled catheter 200 above the intended location of the blazed Bragg grating 245 in the source optical fiber 220. As discussed above, the depth of the groove in the assembled catheter 200 can play a role in the efficiency of the acoustic wave production (e.g., quarter wave matching). After the photoacoustic member 230 location has been defined, the blazed Bragg grating 225 can be added to the source optical fiber 220. In one example, the grating 225 is created using an optical process in which the portion of the source optical fiber 220 is exposed to a carefully controlled pattern of UV radiation that defines the blazed Bragg grating 225. After the blazed Bragg grating 225 is complete, a photoacoustic material is deposited or otherwise added over the blazed Bragg grating 225 to complete the photoacoustic member 230. An exemplary photoacoustic material is pigmented polydimethylsiloxane (PDMS), such as a mixture of PDMS, carbon black, and toluene. The photoacoustic materials may naturally absorb the light from the source optical fiber 220, or the photoacoustic material may be supplemented with dyes, e.g., organic dyes, or nanomaterials (e.g., quantum dots) that absorb the light strongly. The photoacoustic material can also be "tuned" to selectively absorb specific wavelengths by selecting suitable components.

[0064] While not shown in the figures, the described catheters may include radiopaque markers at various locations on or within the catheter to identify structures, e.g., with fluoroscopy. The radiopaque markers will be small in most instances, having a longitudinal dimension of less than 5 mm, e.g., less than 4 mm, e.g., less than 3 mm, e.g., less than 2 mm, e.g., less than 1 mm. The radiopaque markers will be at least 0.2 mm, e.g., at least 0.3 mm, e.g., at least 0.4 mm, e.g., at least 0.5 mm. The radiopaque markers may vary in axial size or diameter, depending upon their shape; however it will necessarily be small enough to fit within a catheter, e.g., catheter 100 or 200. The radiopaque markers may be constructed from any material that does not transmit x-rays and has suitable mechanical properties, including platinum, palladium, rhenium, tungsten, and tantalum.

[0065] An alternative embodiment is an aspiration catheter 300, suitable for imaging, aspirating, and sensor measure-

ment. The distal end 110 of the aspiration catheter 300 is shown in FIGS. 3A and 3B. FIG. 3A shows a side view of the aspiration catheter 300 that uses piezoelectric elements as ultrasound transducers 140 and ultrasound receivers 150 to produce and receive ultrasound energy for imaging. Catheter 300 includes a proximal end (not shown), a mid-body (not shown), and a distal end 110 including a distal tip 115. The distal end 110 includes an aspiration lumen 128 connected to an aspiration port 127, and guidewire lumen 130 terminating in guidewire exit 135. The aspiration lumen 128 runs to the proximal end of the catheter, and is connected to a vacuum source exterior to the catheter 300. The distal tip 115 comprises Doppler sensor 160. The entire distal end 110 is coated with a lubricious coating 170, and a suitable ultrasound transparent material is used to cover the ultrasound transducers 140 and ultrasound receivers 150.

[0066] As can be seen more clearly in FIG. 3B, the transducers 140 and receivers 150 are coaxially located with the aspiration lumen 128 to maximize the inside diameter of the aspiration lumen 128 with respect to the diameter of the distal end 110 of the device. This detail can also be seen in FIG. 4B, which depicts a cross section from A to A in FIG. 1A. Other embodiments of the invention need not adopt this design. For example aspiration lumen may run to one side of the ultrasound transducers 140 and receivers 150.

[0067] The Doppler sensor 160, located in the distal tip 115 of the device allows a physician to observe blood flow in proximity to the tissues being imaged and aspirated. The Doppler sensor is electrically connected (not shown) to the proximal end of the device, which provides power for the sensor and a return path for recovering measurements. Typically, the sensor produces ultrasound in the range of 5 to 15 MHz, e.g., about 12 MHz. In other embodiments, the Doppler sensor may be replaced with an acoustic therapy transducer (not shown) to deliver acoustic waves to a tissue being treated. Acoustic therapy transducers typically operate in the range of 100 kHz and 5 MHz. Because the Doppler sensor and the acoustic therapy transducers are rather small, it is also possible for a device to include both a Doppler sensor and an acoustic therapy transducer.

[0068] A distal end view of catheter 100 and catheter 200 is identical, as shown in FIG. 4A. Regarding FIG. 4A, two drug delivery ports 125, the Doppler sensor 160, and the guidewire exit 135 are visible at the distal tip 115. This design allows the catheter 100/200 to be guided to a tissue in need of treatment along a guidewire, a therapeutic delivered to the tissue, and the results of the therapy (e.g., flow increase) evaluated with the Doppler sensor 160. In other embodiments, the distal tip 115 may include a separate transducer to provide acoustic therapy (not shown). In other embodiments, the distal tip 115 may include a lens coupled to an optical fiber (not shown) to allow phototherapy to be delivered, or to provide photoactivation of a therapeutic agent.

[0069] Cross-sectional views of catheters 100 and 200 are shown in FIGS. 4B and 4C, respectively. FIG. 4B corresponds to the cross-section taken at line AA in FIG. 1A, and FIG. 4C corresponds to the cross-section taken at line BB in FIG. 2A. Both cross sections show drug-delivery lumen 120, used to deliver a therapeutic to tissues in need thereof. FIG. 4B also shows ultrasound transducers 140, surrounding drug-delivery lumen 120, and guidewire lumen 130.

[0070] FIG. 4C shows photoacoustic member 230, source optical fiber 220, photoreflective members 250 and return optical fibers 240, corresponding to catheter 200. As shown in

FIG. 4C, the photoacoustic member 230 and the photoreflective members 250 are substantially in communication with the exterior of the catheter. The photoacoustic member 230 and the photoreflective members 250 are also coupled to the respective optical fibers, i.e., with blazed Bragg gratings, as discussed above. While not shown in FIGS. 4B and 4C, one or more power/signal wires will also pass through the cross sectional view, providing power to, and receiving signals from, Doppler sensor 160. Embodiments having an additional fiber running to the distal tip 115, for example to produce acoustic energy using an additional photoacoustic material, will also run through the cross sections shown in FIGS. 4B and 4C. While not shown herein, it is possible to stagger a plurality of photoacoustic members 230 and photoreflective members 250 longitudinally along the length of catheter 200 to provide greater radial coverage. Alternatively, the catheter 200 may be rotated during imaging to provide improved image quality or to avoid blind spots due to the configuration of the photoacoustic members 230 and photoreflective members 250.

[0071] Other embodiments may combine delivery therapies with optical coherence tomography (OCT) imaging. In OCT, light from a broad band light source or tunable laser source is split by an optical fiber splitter with one fiber directing light to the distal end of a catheter, e.g., for imaging a tissue, and the other fiber directing light to a reference mirror. The distal end of the optical fiber is interfaced with the distal end of a catheter for interrogation of tissues, etc. The light emerges from the optical fiber and is reflected from the tissue being imaged. The reflected light from the tissue is collected with the optical fiber and recombined with the signal from the reference mirror forming interference fringes (measured by a detector) allowing precise depth-resolved imaging of the tissue on a micron scale.

[0072] An alternative embodiment, configured to image the tissues with OCT is shown in FIGS. 5A and 5B. FIG. 5A shows a side view of an imaging/delivery/evaluation catheter 500 that rotational OCT imaging to evaluate tissues before and after treatment. Catheter 500 includes a proximal end (not shown), a mid-body (not shown), and a distal end 110 including a distal tip 115. The distal end 110 includes drug delivery lumen 120 connected to drug delivery ports 125, and guidewire lumen 130 terminating in guidewire exit 135. The distal tip 115 comprises Doppler sensor 160. The entire distal end 110 is coated with a lubricious coating 170, and a suitable ultrasound transparent material is used to cover the ultrasound transducers 140 and ultrasound receivers 150.

[0073] Catheter 500 includes rotational element 320 and mirror 330 which direct light out of an optical fiber (not shown) and collect light that scatters off of the imaged tissue for the purpose of creating tissue measurements using the technique of optical coherence tomography (OCT), OCT typically uses a superluminescent diode source or tunable laser source emitting a 400-2000 nm wavelength, with a 50-250 nm band width (distribution of wave length) to make in-situ tomographic images with axial resolution of 2-20 μm and tissue penetration of 2-3 mm. The near infrared light sources used in OCT instrumentation can penetrate into heavily calcified tissue regions characteristic of advanced coronary artery disease. With cellular resolution, application of OCT may be used to identify other details of the vulnerable plaque such as infiltration of monocytes and macrophages. In short, application of OCT can provide detailed images of a pathologic specimen without cutting or disturbing the tissue.

[0074] The rotational element 320 may only rotate, or the rotational element 320 may translate and rotate, i.e., pull-back imaging. The principles of pull-back OCT devices are described in detail in U.S. Pat. No. 7,813,609 and US Patent Publication No. 200900431911 both of which are incorporated herein by reference in their entireties.

[0075] Because of the presence of the rotational element 320, the drug delivery lumen 120 is axially displaced. Other embodiments of the invention need not adopt this design. For example, drug delivery lumen 120 may comprise multiple lumens that are arranged about rotational element 320 to provide adequate throughput for the delivery of therapeutic agents, typically formulated as a liquid. Additionally, while the views of FIGS. 5A and 5B depict six drug delivery ports 125, this number is arbitrary. The drug delivery lumen 120 merely needs one or more exit ports to allow the therapeutic to be delivered external to the distal end 110.

[0076] The Doppler sensor 160, located in the distal tip 115 of the device allows a physician to observe blood flow in proximity to the tissues being imaged and treated. The Doppler sensor is electrically connected (not shown) to the proximal end of the device, which provides power for the sensor and a return path for recovering measurements. Typically, the sensor produces ultrasound in the range of 5 to 15 MHz, e.g., about 12 MHz. In other embodiments, the Doppler sensor may be replaced with an acoustic therapy transducer (not shown) to deliver acoustic waves to a tissue being treated. Acoustic therapy transducers typically operate in the range of 100 kHz and 5 MHz. Because the Doppler sensor and the acoustic therapy transducers are rather small, it is also possible for a device to include both a Doppler sensor and an acoustic therapy transducer.

[0077] The corresponding proximal end 610 of a catheter 600 is shown in FIG. 6. The proximal end 610 is not inserted into the body, and includes a drug delivery branch 620, essentially a tube, and a port 630, which may comprise a Luer lock or other compatible interface for attaching to a container, e.g., a syringe, containing the therapeutic to be delivered. The drug delivery branch 620 connects to drug delivery lumen 120, which runs the length of the catheter 600 to a distal end, which may correspond to FIGS. 1-5. The embodiment depicted in FIG. 6 is also suitable for use with other embodiments requiring different or additional fluidic communication, such as an aspiration catheter or a balloon catheter needing an inflation fluid. In some instances, the proximal end may comprise the drug delivery branch 620 and in addition to a similar fabricated aspiration branch (not shown).

[0078] The proximal end 610 will also include one or more electrical connections 145 in communication with electrical components at the distal end, e.g., ultrasound transducer 140, ultrasound receiver 150, or Doppler sensor 160. The proximal end 610 may further comprise one or more optical fibers 165 in optical communication with optical components at the distal end, e.g., photoacoustic member 230, photoreflective member 250 or an embodiment of the Doppler sensor 160 including a photoacoustic material. The electrical connections 145 and/or the optical fibers 165 exit the proximal end 610 of the catheter 600 at or near the proximal tip, where they are coupled to electro-optical components for imaging and evaluation. In some embodiments, the electrical connections 145 and/or the optical fibers 165 are bundled into a pigtail 723 having a connector designed to interconnect with a Patient Interface Module (PIM), discussed below.

[0079] A system 700, including a multifunction catheter 710, is shown in FIG. 7. As discussed above, the catheter 710 may include a pigtail 723, including the needed electrical/optical connections, and a fluid delivery branch 727. The pigtail 723 is connected to a Patient Interface Module (PIM) 730 that provides the needed signals to produce acoustic energy for imaging and therapy, and receives the return signals to produce images of the tissues or to diagnose the environment in proximity to the tissues.

[0080] As shown in FIG. 7, the PIM 730 comprises multiple components, each controlling an aspect of the task. The power controller 732 receives power from an external source and conditions or modifies the power, as needed, to drive a transducer or to power a light source. The network controller 734 allows the PIM 730 to communicate with outside components, such as image processing 730 (discussed below). The network controller 734 may be configured to operate wirelessly (e.g., WIFI or 4G), with a wired connection, or through an optical connection, which will allow MHz signals to be processed easier away from the PIM 730. The imaging controller 736 will coordinate production of acoustic energy and reception of the reflected energy, as needed to image the tissues. The imaging controller may control one or more light sources as needed for photoacoustic generation and photoreflective reception. The diagnostic controller 738 will coordinate measurement of diagnostic values, such as blood flow, blood pressure, temperature, or blood oxygenation, for example by interacting with Doppler sensor 160. The therapy controller 740 will control therapy delivery, for example acoustic or photo therapy, delivered with the distal end of the catheter 710.

[0081] In embodiments using optical fibers, such as catheter 200, the source light and the return light may be coupled or split with fiber couplers, dichroics, and filters as necessary to achieve the desired performance. Additionally, multiple light sources may be used or only a single light source. Furthermore, a particular fiber need not be limited to a single light source, as some fibers can support multiple wavelengths simultaneously and the wavelengths can be separated for analysis using known multiplexing techniques. These functions will be controlled by the imaging controller 736.

[0082] The sources of light may be any known light source configured to produce light with the desired temporal and frequency characteristics, for example, solid-state lasers, gas lasers, dye lasers, or semiconductor lasers. The sources may also be LED or other broadband sources, provided that the sources are sufficiently powerful to drive the photoacoustic transducers. In some instances the imaging controller 736 will gate the sources to provide the needed temporal resolution. In other instances, the sources will inherently provide short pulses of light at the desired frequency, e.g., 20 MHz, and the imaging controller will synchronize other imaging tasks to this natural frequency. Embodiments using optical fibers for acoustic signal collection will additionally include a detector (not shown) coupled to return fiber 240. The detector will be used to monitor changes to the coupled light to determine how the acoustic environment of the catheter 200 is changing. The detector may be a photodiode, photomultiplier tube, charge coupled array, microchannel detector, or other suitable detector. The detector may directly observe shifts in return light pulses, e.g., due to deflection of the photoreflective material, or the detector may observe interferometric changes in the returned light due to changes in path length or

shape. Fourier transformation from time to frequency can also be used to improve the resolution of the detection.

[0083] At least a portion of the output from the PIM 730 will be directed to image processing 760 prior to being output to a display 770 for viewing. The image processing will deconvolve received signals to produce distance and/or tissue measurements, and those distance and tissue measurements will be used to produce an image, for example an intravascular ultrasound (IVUS) image. The image processing may additionally include spectral analysis, i.e., examining the energy of the returned acoustic signal at various frequencies. Spectral analysis is useful for determining the nature of the tissue and the presence of foreign objects. A plaque deposit, for example, will typically have a different spectral signature than nearby vascular tissue without such plaque, allowing discrimination between healthy and diseased tissue. Also a metal surface, such as a stent, will have a different spectral signal. Such signal processing may additionally include statistical processing (e.g., averaging, filtering, or the like) of the returned ultrasound signal in the time domain. Other signal processing techniques known in the art of tissue characterization may also be applied.

[0084] Other image processing may facilitate use of the images or identification of features of interest. For example, the border of a lumen may be highlighted or plaque deposits may be displayed in a visually different manner (e.g., by assigning plaque deposits a discernible color) than other portions of the image. Other image enhancement techniques known in the art of imaging may also be applied. In a further example, similar techniques can be used to discriminate between vulnerable plaque and other plaque, or to enhance the displayed image by providing visual indicators to assist the user in discriminating between vulnerable and other plaque. Other measurements, such as flow rates or pressure may be displayed using color mapping or by displaying numerical values.

[0085] As shown in FIG. 7, a fluid delivery device 750 will be coupled to the fluid delivery branch 727 to allow a physician to deliver one or more therapeutics to tissues needing treatment. Alternatively, the fluid delivery device 750 can be used to deliver an inflation fluid (e.g., saline) to an angioplasty balloon or an ablation balloon. The fluid delivery device 750 can be any suitable container for delivering a fluid, e.g., a therapeutic agent, typically in a liquid form. The fluid delivery device 750 may be a syringe, a pump, an IV bag, and ampule, or a vial. In some embodiments, the fluid delivery device 750 is a syringe pump that is interfaced to the PIM, allowing the flow of therapeutics to be coordinated with other activities, e.g., acoustic therapy or photoactivation.

[0086] In other embodiments, a system may comprise a vacuum aspiration pump or additional mechanical components, e.g., rotary power, as needed to achieve the desired procedures.

[0087] In embodiments using OCT, the system 700 will additionally comprise an OCT subsystem, depicted in FIGS. 8A and 8B. Generally, an OCT system comprises three components which are 1) an imaging catheter 2) OCT imaging hardware, 3) host application software. When utilized, the components are configured to obtain OCT data, process OCT data, and transmit captured data to a host system. OCT systems and methods are generally described in Milner et al., U.S. Patent Application Publication No. 2011/0152771, Condit et al., U.S. Patent Application Publication No. 2010/0220334, Castella et al., U.S. Patent Application Publication

No. 2009/0043191, Milner et al., U.S. Patent Application Publication No. 2008/0291463, and Kemp, N., U.S. Patent Application Publication No. 2008/0180683, the content of each of which is incorporated by reference in its entirety. In certain embodiments, systems and methods of the invention include processing hardware configured to interact with more than one different three dimensional imaging system so that the tissue imaging devices and methods described here in can be alternatively used with OCT, IVUS, or other hardware.

[0088] In OCT, a light source delivers a beam of light to an imaging device to image target tissue. Light sources can be broad spectrum light sources, or provide a more limited spectrum of wavelengths, e.g., near infra-red. The light sources may be pulsed or continuous wave. For example the light source may be a diode (e.g., superluminescent diode), or a diode array, a semiconductor laser, an ultrashort pulsed laser, or supercontinuum light source. Typically the light source is filtered and allows a user to select a wavelength of light to be amplified. Wavelengths commonly used in medical applications include near-infrared light, for example between about 800 nm and about 1700 nm. Methods of the invention apply to image data obtained from obtained from any OCT system, including OCT systems that operate in either the time domain or frequency (high definition) domain.

[0089] In time-domain OCT, an interference spectrum is obtained by moving a scanning optic, such as a reference mirror, longitudinally to change the reference path and match multiple optical paths due to reflections of the light within the sample. The signal giving the reflectivity is sampled over time, and light traveling at a specific distance creates interference in the detector. Moving the scanning mechanism laterally (or rotationally) across the sample produces reflectance distributions of the sample (i.e., an imaging data set) from which two-dimensional and three-dimensional images can be produced.

[0090] In frequency domain OCT, a light source configured to emit a range of optical frequencies passes through an interferometer, where the interferometer combines the light returned from a sample with a reference beam of light from the same source, and the intensity of the combined light is recorded as a function of optical frequency to form an interference spectrum. A Fourier transform of the interference spectrum provides the reflectance distribution along the depth within the sample.

[0091] Several methods of frequency domain OCT are described in the literature. In spectral-domain OCT (SD-OCT), also sometimes called "Spectral Radar" (*Optics Letters*, vol. 21, No. 14 (1996) 1087-1089), a grating or prism or other means is used to disperse the output of the interferometer into its optical frequency components. The intensities of these separated components are measured using an array of optical detectors, each detector receiving an optical frequency or a fractional range of optical frequencies. The set of measurements from these optical detectors forms an interference spectrum (Smith, L. M. and C. C. Dobson, *Applied Optics* vol. 28: (1989) 3339-3342), wherein the distance to a scatterer is determined by the wavelength dependent fringe spacing within the power spectrum. SD-OCT has enabled the determination of distance and scattering intensity of multiple scatters lying along the illumination axis by analyzing the exposure of an array of optical detectors so that no scanning in depth is necessary.

[0092] Alternatively, in swept-source OCT, the interference spectrum is recorded by using a source with adjustable

optical frequency, with the optical frequency of the source swept through a range of optical frequencies, and recording the interfered light intensity as a function of time during the sweep. An example of swept-source OCT is described in U.S. Pat. No. 5,321,501.

[0093] Time- and frequency-domain systems can further vary based upon the optical layout of the systems: common beam path systems and differential beam path systems. A common beam path system sends all produced light through a single optical fiber to generate a reference signal and a sample signal whereas a differential beam path system splits the produced light such that a portion of the light is directed to the sample and the other portion is directed to a reference surface. Common beam path systems are described in U.S. Pat. No. 7,999,938; U.S. Pat. No. 7,995,210; and U.S. Pat. No. 7,787,127 and differential beam path systems are described in U.S. Pat. No. 7,783,337; U.S. Pat. No. 6,134,003; and U.S. Pat. No. 6,421,164, the contents of each of which are incorporated by reference herein in their entireties.

[0094] In certain embodiments, the invention provides a differential beam path OCT system with intravascular imaging capability as illustrated in FIG. 8A. For intravascular imaging, a light beam is delivered to the vessel lumen via a fiber-optic based imaging catheter **826**, which is a multifunction catheter of the invention. The imaging catheter is connected through hardware to software on a host workstation. The hardware includes imaging engine **859** and a handheld patient interface module (PIM) **839** that includes user controls. The proximal end of imaging catheter **826** is connected to PIM **839**, which is connected to imaging engine **859** as shown in FIG. 8A.

[0095] An embodiment of imaging engine **859** is shown in FIG. 8B. Imaging engine **859** (i.e., the bedside unit) houses power distribution board **849**, light source **827**, interferometer **831**, and variable delay line **835** as well as a data acquisition (DAQ) board **855** and optical controller board (OCB) **851**. PIM cable **841** connects imaging engine **859** to PIM **839** and engine cable **845** connects imaging engine **859** to the host workstation (not shown).

[0096] FIG. 9 shows an exemplary light path in a differential beam path system which may be used in an OCT system suitable for use with the invention. Light for producing the measurements originates within light source **827**. This light is split between main OCT interferometer **905** and auxiliary interferometer **911**. In some embodiments, the auxiliary interferometer is referred to as a "clock" interferometer. Light directed to main OCT interferometer **905** is further split by splitter **917** and recombined by splitter **919** with an asymmetric split ratio. The majority of the light from splitter **917** is guided into sample path **913** while the remainder goes into reference path **915**. Sample path **917** includes optical fibers running through PIM **839** and imaging catheter core **826** and terminating at the distal end of the imaging catheter, where the sample is measured.

[0097] The reflected light is transmitted along sample path **913** to be recombined with the light from reference path **915** at splitter **919**. A variable delay line (VDL) **925** on the reference path uses an adjustable fiber coil to match the length of reference path **915** to the length of sample path **913**. The reference path length is adjusted by a stepper motor translating a mirror on a translation stage under the control of firmware or software.

[0098] The combined light from splitter **919** is split into orthogonal polarization states, resulting in RF-band polariza-

tion-diverse temporal interference fringe signals. The interference fringe signals are converted to photocurrents using PIN photodiodes **929a**, and **929b**, on optical controller board (OCB) **851**. The interfering, polarization splitting, and detection steps are done by a polarization diversity module (PDM) (not shown) on OCB **851**. Signal from OCB **851** is sent to DAQ **855**, shown in FIG. 9. DAQ **855** includes a digital signal processing (DSP) microprocessor and a field programmable gate array (FPGA) to digitize signals and communicate with the host workstation and PIM **839**. The FPGA converts raw optical interference signals into meaningful reflectivity measurements. DAQ **855** also compresses data as necessary to reduce image transfer bandwidth, e.g., to 1 Gbps, e.g., by compressing frames with a glossy compression JPEG encoder.

[0099] Additional embodiments of the invention including other combinations of imaging, treatment and assessment will be evident to those of skill in the art in view of this disclosure and the claims below.

INCORPORATION BY REFERENCE

[0100] References and citations to other documents, such as patents, patent applications, patent publications, journals, books, papers, and web contents, have been made throughout this disclosure. All such documents are hereby incorporated herein by reference in their entirety for all purposes.

EQUIVALENTS

[0101] Various modifications of the invention and many further embodiments thereof, in addition to those shown and described herein, will become apparent to those skilled in the art from the full contents of this document, including references to the scientific and patent literature cited herein. The subject matter herein contains important information, exemplification and guidance that can be adapted to the practice of this invention in its various embodiments and equivalents thereof.

What is claimed is:

1. A device configured to image a tissue, deliver a therapy to the tissue, and measure a property of an environment associated with the tissue.
2. The device of claim 1, wherein the device is configured with an intravascular ultrasound (IVUS) component to image the tissue.
3. The device of claim 2, wherein the IVUS component comprises a piezoelectric transducer.
4. The device of claim 2, wherein the IVUS component comprises a photoacoustic material coupled to an optical fiber.
5. The device of claim 1, wherein the device is configured with optical coherence tomography (OCT) component to image the tissue.
6. The device of claim 1, wherein the therapy comprises delivering a solution comprising a therapeutic agent.
7. The device of claim 1, wherein the therapy is aspirating a tissue.
8. The device of claim 1, wherein the therapy is angioplasty.
9. The device of claim 1, wherein the therapy is ablation.
10. The device of claim 1, wherein the therapy is placing a medical device selected from the group consisting of a strut, a stent, a valve, and a filter.
11. The device of claim 1, wherein the property is selected from the group consisting of blood flow in a vessel, blood pressure in a vessel, blood oxygenation in a vessel, temperature, presence of a chemical species, and a combination thereof.
12. The device of claim 1, wherein the device is additionally configured to make at least one spectroscopic measurement selected from the group consisting of infrared absorption, visible absorption, Raman, and fluorescence.
13. The device of claim 1, wherein the device is a catheter.

* * * * *

专利名称(译)	同时成像，监测和治疗		
公开(公告)号	US20140180034A1	公开(公告)日	2014-06-26
申请号	US14/134184	申请日	2013-12-19
[标]申请(专利权)人(译)	火山公司		
申请(专利权)人(译)	火山CORPORATION		
当前申请(专利权)人(译)	火山CORPORATION		
[标]发明人	HOSEIT PAUL HUENNEKENS SCOTT		
发明人	HOSEIT, PAUL HUENNEKENS, SCOTT		
IPC分类号	A61B5/00 A61B8/12		
CPC分类号	A61B8/445 A61B2018/0022 A61B18/1492 A61B2218/007 A61B2018/00863 A61B5/0073 A61B2017/22001 A61B5/6852 A61B2018/00422 A61B5/4839 A61B5/6847 A61B5/0066 A61N7/00 A61B8/12 A61B5/0086 A61B8/488 A61B2018/00791 A61N2007/0043		
优先权	61/745119 2012-12-21 US		
其他公开文献	US10058284		
外部链接	Espacenet USPTO		

摘要(译)

使用所公开的血管内装置，可以在递送治疗后对组织成像，递送治疗和评估组织。一个实施例是配置成提供超声成像，药物输送和多普勒流分析的导管。这些设备可以使用超声成像以及光学相干断层扫描(OCT)。

