



US010213335B2

(12) **United States Patent**
Burnett et al.

(10) **Patent No.:** **US 10,213,335 B2**
(45) **Date of Patent:** ***Feb. 26, 2019**

(54) **METHODS AND APPARATUS FOR CRYOGENIC TREATMENT OF A BODY CAVITY OR LUMEN**

(71) Applicant: **Channel Medsystems, Inc.**, Emeryville, CA (US)

(72) Inventors: **Daniel R. Burnett**, San Francisco, CA (US); **Brian M. Neil**, San Francisco, CA (US); **William W. Malecki**, Piedmont, CA (US); **Kathleen M. Koch**, San Francisco, CA (US); **Gregory J. Lee**, San Francisco, CA (US)

(73) Assignee: **Channel Medsystems, Inc.**, Emeryville, CA (US)

(*) Notice: Subject to any disclaimer, the term of this patent is extended or adjusted under 35 U.S.C. 154(b) by 279 days.

This patent is subject to a terminal disclaimer.

(21) Appl. No.: **15/065,684**

(22) Filed: **Mar. 9, 2016**

(65) **Prior Publication Data**
US 2016/0183999 A1 Jun. 30, 2016

Related U.S. Application Data
(63) Continuation of application No. 13/361,779, filed on Jan. 30, 2012, now Pat. No. 9,283,022.
(Continued)

(51) **Int. Cl.**
A61B 18/02 (2006.01)
A61F 7/12 (2006.01)
(Continued)

(52) **U.S. Cl.**
CPC **A61F 7/123** (2013.01); **A61B 5/01** (2013.01); **A61B 5/4836** (2013.01);
(Continued)

(58) **Field of Classification Search**
CPC .. **A61B 2018/0268**; **A61B 2018/00011**; **A61B 2018/0022**; **A61B 2018/00488**;
(Continued)

(56) **References Cited**
U.S. PATENT DOCUMENTS

2,849,002 A 8/1958 Oddo
3,398,738 A 8/1968 Lamb et al.
(Continued)

FOREIGN PATENT DOCUMENTS

CN 102596119 7/2012
GB 2094636 9/1982
(Continued)

Primary Examiner — Michael F Peffley
(74) *Attorney, Agent, or Firm* — Levine Bagade Han LLP

(57) **ABSTRACT**
Methods and apparatus for the treatment of a body cavity or lumen are described where a heated fluid and/or gas may be introduced through a catheter and into treatment area within the body contained between one or more inflatable/expandable members. The catheter may also have optional pressure and temperature sensing elements which may allow for control of the pressure and temperature within the treatment zone and also prevent the pressure from exceeding a pressure of the inflatable/expandable members to thereby contain the treatment area between these inflatable/expandable members. Optionally, a chilled, room temperature, or warmed fluid such as water may then be used to rapidly terminate the treatment session.

24 Claims, 52 Drawing Sheets

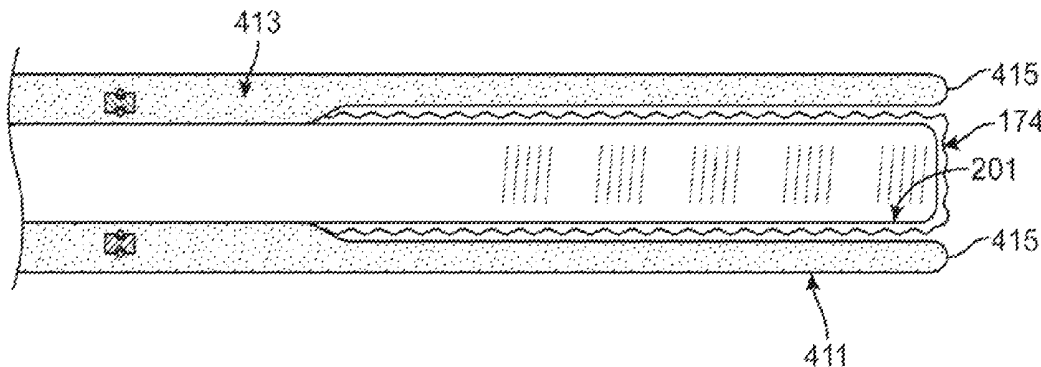

| Related U.S. Application Data | | | | | |
|--------------------------------------|--|--------------|-----------------|--------------|-------------------------------|
| | | 6,235,019 | B1 | 5/2001 | Lehmann et al. |
| | | 6,241,722 | B1 | 6/2001 | Dobak et al. |
| | | 6,260,439 | B1 | 8/2001 | Martin et al. |
| | | 6,270,476 | B1 | 8/2001 | Santojanni et al. |
| (60) | Provisional application No. 61/462,328, filed on Feb. 1, 2011, provisional application No. 61/571,123, filed on Jun. 22, 2011. | 6,270,493 | B1 | 8/2001 | Lalonde et al. |
| | | 6,283,959 | B1 | 9/2001 | Lalonde et al. |
| | | 6,290,696 | B1 | 9/2001 | Lafontaine |
| | | 6,302,904 | B1 | 10/2001 | Wallsten et al. |
| | | 6,355,029 | B1 | 3/2002 | Jaye et al. |
| | | 6,364,874 | B1 | 4/2002 | Bays et al. |
| | | 6,497,703 | B1 | 12/2002 | Korteling et al. |
| | | 6,517,533 | B1 * | 2/2003 | Swaminathan A61B 18/0218 |
| (51) | Int. Cl. | | | | |
| | <i>A61B 18/04</i> (2006.01) | | | | |
| | <i>A61B 17/12</i> (2006.01) | | | | |
| | <i>A61B 5/01</i> (2006.01) | | | | |
| | <i>A61B 5/00</i> (2006.01) | | | | |
| | <i>A61B 17/00</i> (2006.01) | 6,530,234 | B1 | 3/2003 | Dobak, III et al. |
| | <i>A61B 18/00</i> (2006.01) | 6,547,784 | B1 | 4/2003 | Thompson |
| | | 6,554,780 | B1 | 4/2003 | Sampson et al. |
| (52) | U.S. Cl. | 6,569,158 | B1 | 5/2003 | Abboud et al. |
| | CPC <i>A61B 17/12022</i> (2013.01); <i>A61B 18/02</i> (2013.01); <i>A61B 18/0218</i> (2013.01); <i>A61B 18/04</i> (2013.01); <i>A61B 5/6853</i> (2013.01); <i>A61B 2017/00539</i> (2013.01); <i>A61B 2018/00011</i> (2013.01); <i>A61B 2018/0022</i> (2013.01); <i>A61B 2018/00041</i> (2013.01); <i>A61B 2018/00488</i> (2013.01); <i>A61B 2018/00553</i> (2013.01); <i>A61B 2018/00559</i> (2013.01); <i>A61B 2018/00577</i> (2013.01); <i>A61B 2018/00791</i> (2013.01); <i>A61B 2018/00863</i> (2013.01); <i>A61B 2018/00982</i> (2013.01); <i>A61B 2018/0212</i> (2013.01); <i>A61B 2018/0262</i> (2013.01); <i>A61B 2018/046</i> (2013.01) | 6,575,932 | B1 | 6/2003 | O'Brien et al. |
| | | 6,575,933 | B1 | 6/2003 | Wittenberger et al. |
| | | 6,589,234 | B2 | 7/2003 | Lalonde et al. |
| | | 6,595,988 | B2 | 7/2003 | Wittenberger et al. |
| | | 6,602,247 | B2 | 8/2003 | Lalonde |
| | | 6,607,545 | B2 | 8/2003 | Kammerer et al. |
| | | 6,648,878 | B2 | 11/2003 | Lafontaine |
| | | 6,648,879 | B2 | 11/2003 | Joye et al. |
| | | 6,743,184 | B2 | 6/2004 | Sampson et al. |
| | | 6,752,802 | B1 | 6/2004 | Isenberg |
| | | 6,758,831 | B2 | 7/2004 | Ryan |
| | | 6,786,901 | B2 | 9/2004 | Joye et al. |
| | | 6,872,183 | B2 | 3/2005 | Sampson et al. |
| | | 6,875,209 | B2 | 4/2005 | Zvuloni et al. |
| | | 6,951,569 | B2 | 10/2005 | Nohilly |
| (58) | Field of Classification Search | 6,989,009 | B2 | 1/2006 | Lafontaine |
| | CPC A61B 2018/00553; A61B 2018/00559; A61B 2018/0262; A61B 2018/0212; A61B 2018/046; A61B 2018/00791; A61B 2018/0218; A61B 18/02; A61B 18/0218; A61B 17/12022 | 7,022,120 | B2 | 4/2006 | Lafontaine |
| | See application file for complete search history. | 7,063,670 | B2 | 6/2006 | Sampson et al. |
| | | 7,101,367 | B2 | 9/2006 | Xiao et al. |
| | | 7,101,368 | B2 | 9/2006 | Lafontaine |
| | | 7,195,625 | B2 | 3/2007 | Lentz |
| | | 7,198,625 | B1 | 4/2007 | Hui et al. |
| | | 7,306,589 | B2 | 12/2007 | Swanson |
| | | 7,381,208 | B2 | 6/2008 | van der Walt et al. |
| | | 7,500,973 | B2 | 3/2009 | Vancelette et al. |
| | | 7,566,341 | B2 | 7/2009 | Keller et al. |
| | | 7,727,228 | B2 | 6/2010 | Abboud |
| | | 7,785,289 | B2 | 8/2010 | Rios et al. |
| | | 7,794,454 | B2 | 9/2010 | Abboud et al. |
| | | 7,850,681 | B2 | 12/2010 | Lafontaine |
| | | 8,088,125 | B2 | 1/2012 | Lafontaine |
| | | 8,206,345 | B2 | 6/2012 | Abboud et al. |
| | | 8,225,643 | B2 | 7/2012 | Abboud et al. |
| | | 8,382,747 | B2 | 2/2013 | Abboud et al. |
| | | 8,439,906 | B2 | 5/2013 | Watson |
| | | 8,545,491 | B2 | 10/2013 | Abboud et al. |
| | | 8,579,890 | B2 | 11/2013 | Hon |
| | | 8,663,211 | B2 | 3/2014 | Fourkas et al. |
| | | 8,715,274 | B2 | 5/2014 | Watson |
| | | 8,911,434 | B2 | 12/2014 | Wittenberger |
| | | 9,027,389 | B2 | 5/2015 | Abboud et al. |
| | | 9,655,668 | B2 | 5/2017 | Ingle et al. |
| | | 2002/0082635 | A1 | 6/2002 | Kammerer et al. |
| | | 2002/0099364 | A1 * | 7/2002 | Lalonde A61B 18/02 |
| | | | | | 606/21 |
| (56) | References Cited | | | | |
| | U.S. PATENT DOCUMENTS | | | | |
| | 3,696,813 A | 10/1972 | Wallach | | |
| | 3,712,306 A | 1/1973 | Bryne | | |
| | 3,782,386 A | 1/1974 | Barger et al. | | |
| | 3,924,628 A | 12/1975 | Droegemueller | | |
| | 3,948,269 A | 4/1976 | Zimmer | | |
| | 4,072,152 A | 2/1978 | Linehan | | |
| | 4,275,734 A | 6/1981 | Mitchiner | | |
| | 4,416,660 A | 11/1983 | Dafoe | | |
| | 4,949,718 A | 8/1990 | Neuwirth | | |
| | 5,080,660 A | 1/1992 | Buelna | | |
| | 5,084,044 A | 1/1992 | Quint | | |
| | 5,228,441 A | 7/1993 | Lundquist | | |
| | 5,254,116 A | 10/1993 | Baust et al. | | |
| | 5,281,215 A | 1/1994 | Milder | | |
| | 5,334,181 A | 8/1994 | Rubinsky et al. | | |
| | 5,370,134 A | 12/1994 | Chin et al. | | |
| | 5,382,252 A | 1/1995 | Failla | 2003/0153940 | A1 |
| | 5,437,665 A | 8/1995 | Munro | 2004/0034344 | A1 |
| | 5,458,597 A | 10/1995 | Edwards et al. | 2004/0181136 | A1 |
| | 5,501,681 A | 3/1996 | Neuwirth et al. | 2005/0107855 | A1 |
| | 5,769,880 A | 6/1998 | Truckai et al. | 2005/0177147 | A1 |
| | 5,776,129 A | 7/1998 | Mersch | 2005/0177148 | A1 |
| | 5,800,493 A | 9/1998 | Stevens et al. | 2005/0215989 | A1 |
| | 5,827,269 A | 10/1998 | Saadat | 2006/0259023 | A1 |
| | 5,868,735 A | 2/1999 | Lafontaine | 2007/0021741 | A1 |
| | 5,879,347 A | 3/1999 | Saadat | 2007/0088247 | A1 |
| | 5,902,299 A | 5/1999 | Jayaraman | 2007/0203396 | A1 |
| | 5,916,212 A | 6/1999 | Baust et al. | 2007/0237739 | A1 |
| | 5,921,982 A | 7/1999 | Lash et al. | 2008/0188912 | A1 |
| | 5,954,714 A | 9/1999 | Saadat | 2008/0281317 | A1 |
| | 6,057,689 A | 5/2000 | Saadat | 2008/0294154 | A1 |
| | 6,066,132 A | 5/2000 | Chen et al. | 2009/0076573 | A1 |
| | 6,159,160 A | 12/2000 | Hsei et al. | 2009/0138000 | A1 |
| | | | | 8/2003 | Nohilly et al. |
| | | | | 2/2004 | Ryba |
| | | | | 9/2004 | McDaniel et al. |
| | | | | 5/2005 | Lennox et al. |
| | | | | 8/2005 | Vancelette et al. |
| | | | | 8/2005 | van der Walt et al. |
| | | | | 9/2005 | Abboud et al. |
| | | | | 11/2006 | Abboud et al. |
| | | | | 1/2007 | Abboud et al. |
| | | | | 4/2007 | Bliweis et al. |
| | | | | 8/2007 | McCutcheon et al. |
| | | | | 10/2007 | Doty |
| | | | | 8/2008 | Stone et al. |
| | | | | 11/2008 | Gobel |
| | | | | 11/2008 | Ibrahim et al. |
| | | | | 3/2009 | Burnett et al. |
| | | | | 5/2009 | Vancelette et al. |

(56)

References Cited

U.S. PATENT DOCUMENTS

| | | | |
|--------------|----|---------|-----------------|
| 2009/0171349 | A1 | 7/2009 | Byrd et al. |
| 2009/0299355 | A1 | 12/2009 | Bencini et al. |
| 2009/0299356 | A1 | 12/2009 | Watson |
| 2009/0306588 | A1 | 12/2009 | Nguyen et al. |
| 2010/0004595 | A1 | 1/2010 | Nguyen et al. |
| 2010/0049190 | A1 | 2/2010 | Long et al. |
| 2010/0125266 | A1 | 5/2010 | Deem et al. |
| 2010/0198040 | A1 | 8/2010 | Friedman et al. |
| 2011/0082453 | A1 | 4/2011 | Fischer et al. |
| 2011/0152722 | A1 | 6/2011 | Yackel |
| 2012/0089047 | A1 | 4/2012 | Ryba et al. |
| 2012/0101485 | A1 | 4/2012 | Wittenberger |
| 2012/0197245 | A1 | 8/2012 | Burnett et al. |
| 2013/0296837 | A1 | 11/2013 | Burnett et al. |
| 2014/0012156 | A1 | 1/2014 | Burnett et al. |

FOREIGN PATENT DOCUMENTS

| | | |
|----|----------------|---------|
| JP | 5-168646 | 7/1993 |
| WO | WO 1998/017187 | 4/1998 |
| WO | WO 1998/029068 | 7/1998 |
| WO | WO 1999/005979 | 2/1999 |
| WO | WO 1999/027862 | 6/1999 |
| WO | WO 2002/051491 | 7/2002 |
| WO | WO 2010/135602 | 11/2010 |
| WO | WO 2012/106260 | 8/2012 |

* cited by examiner

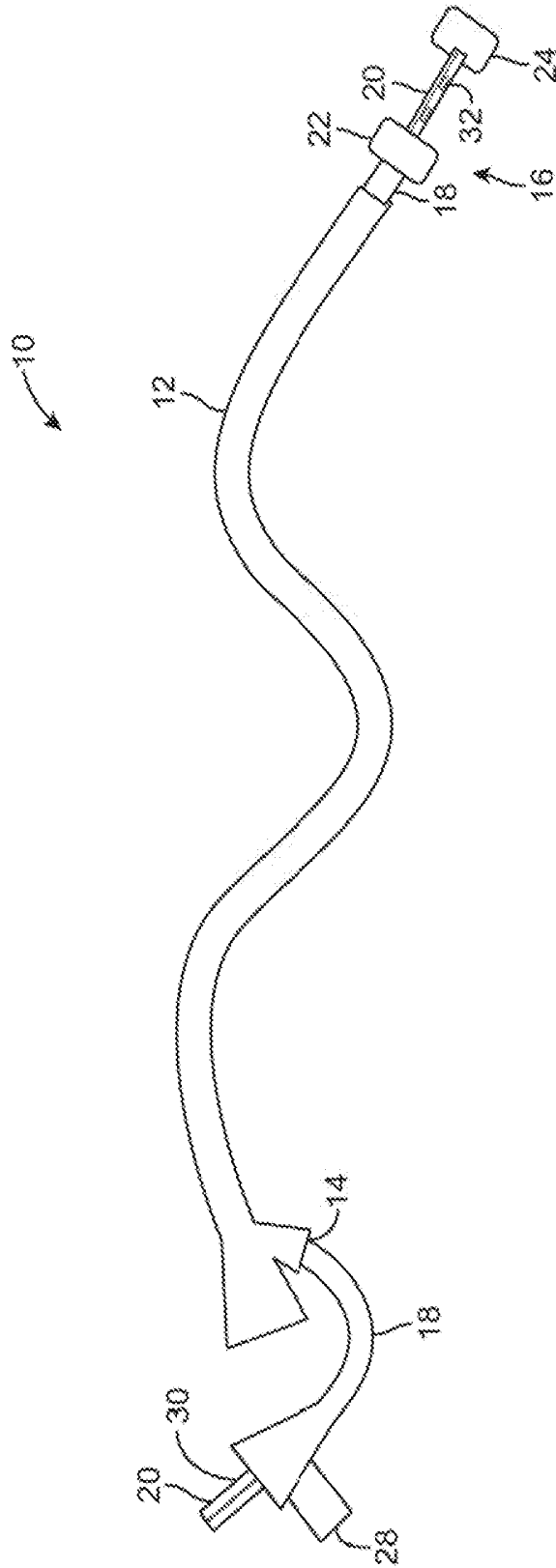

FIG. 1

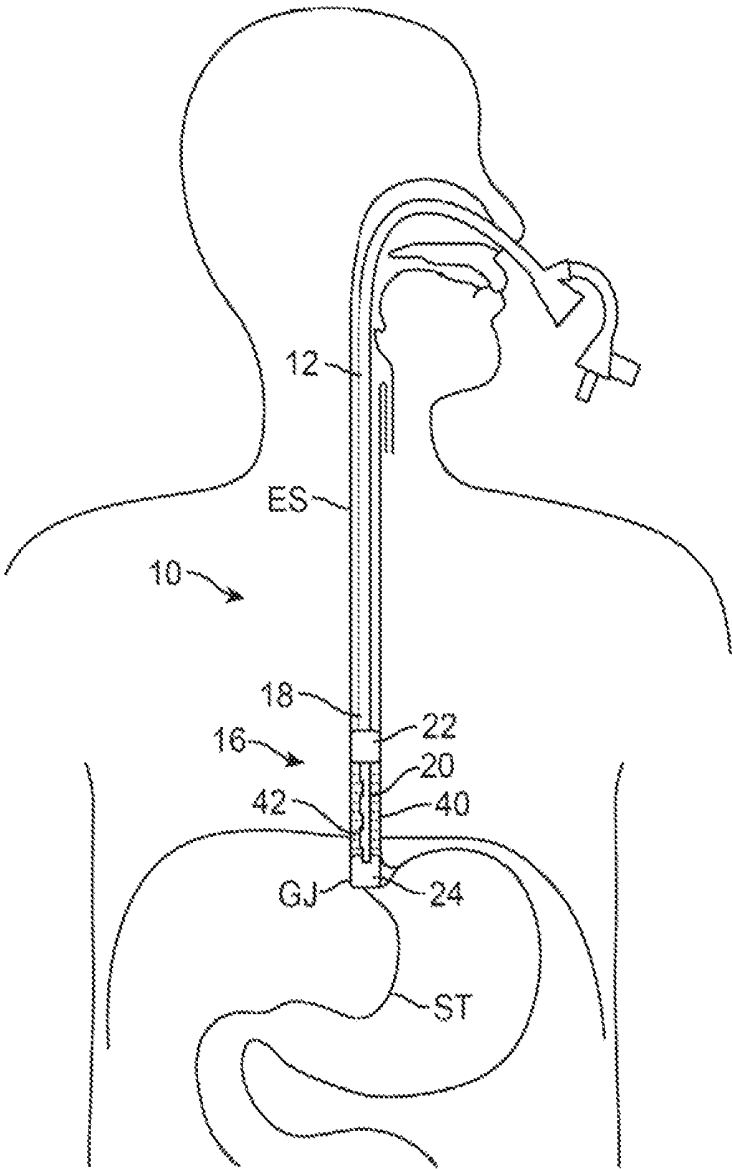

FIG. 2

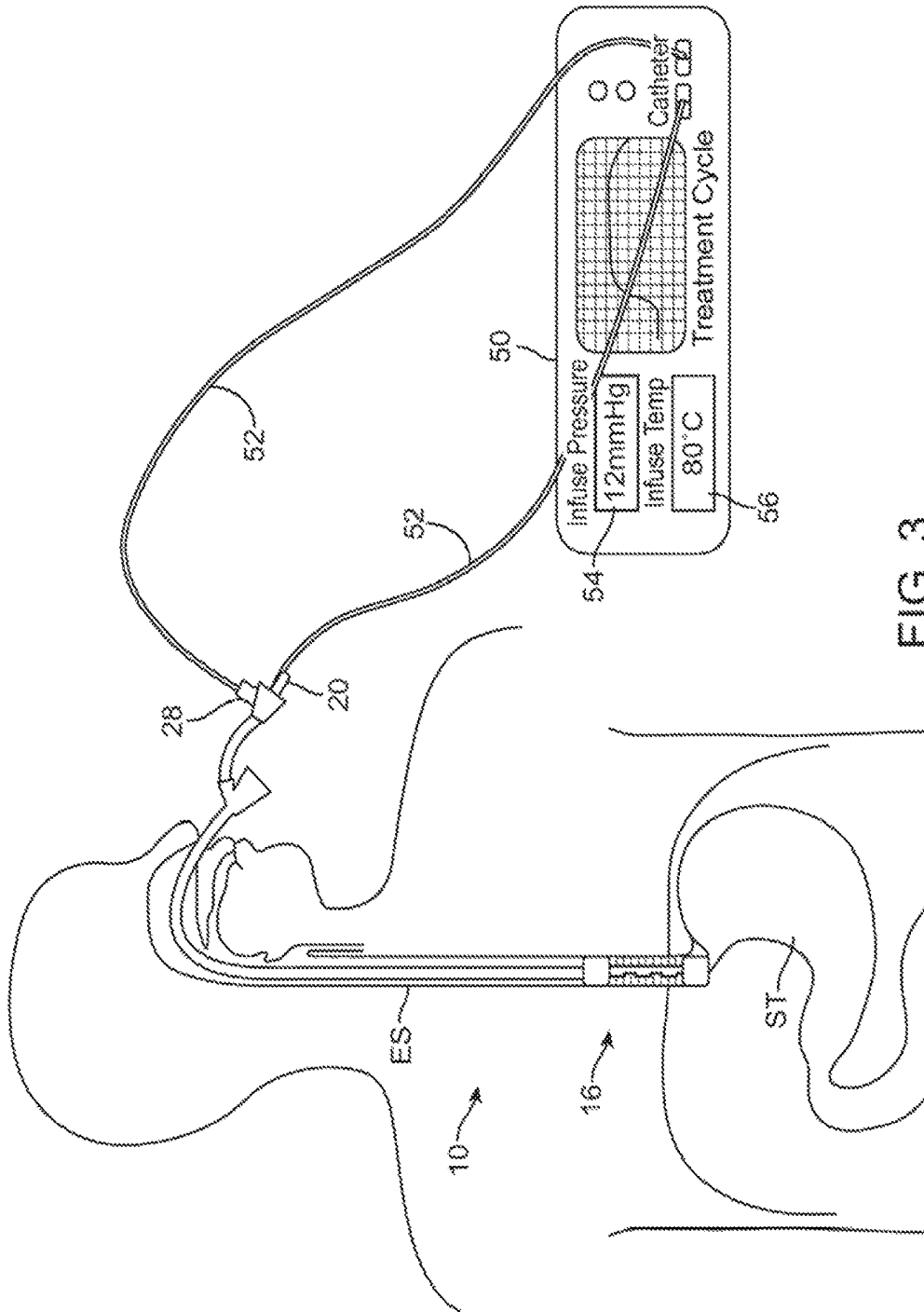

FIG. 3

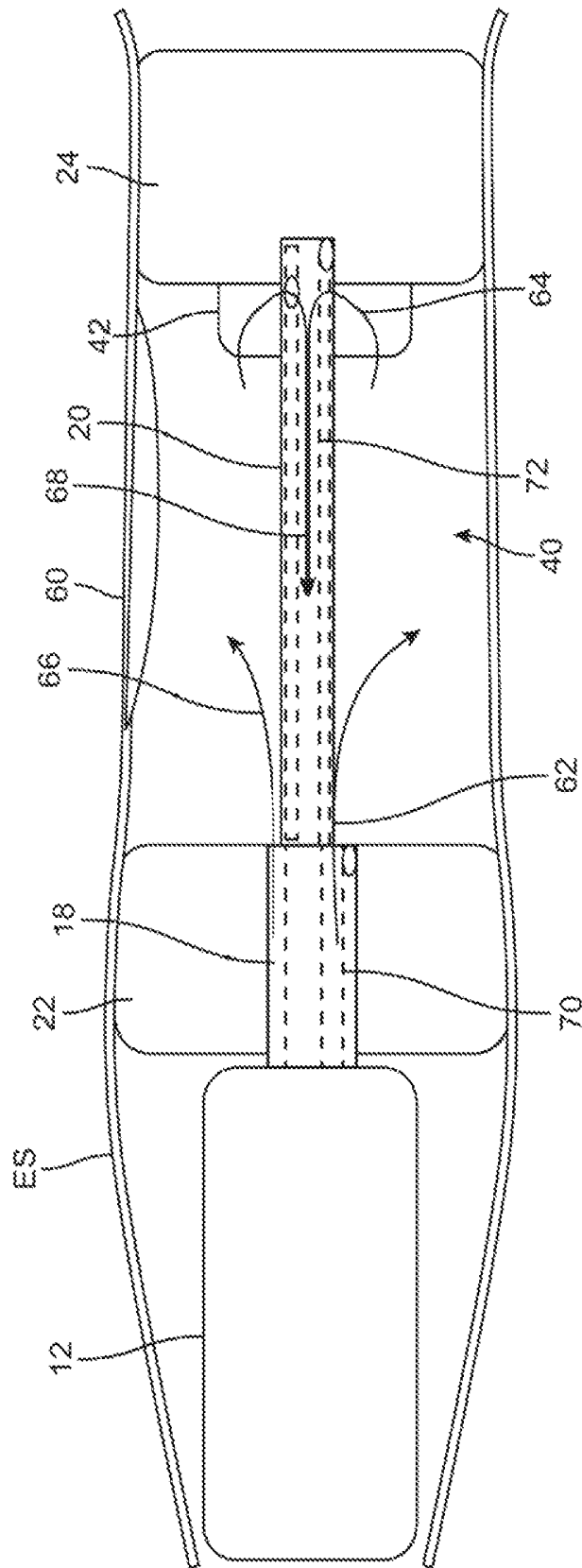

FIG. 4

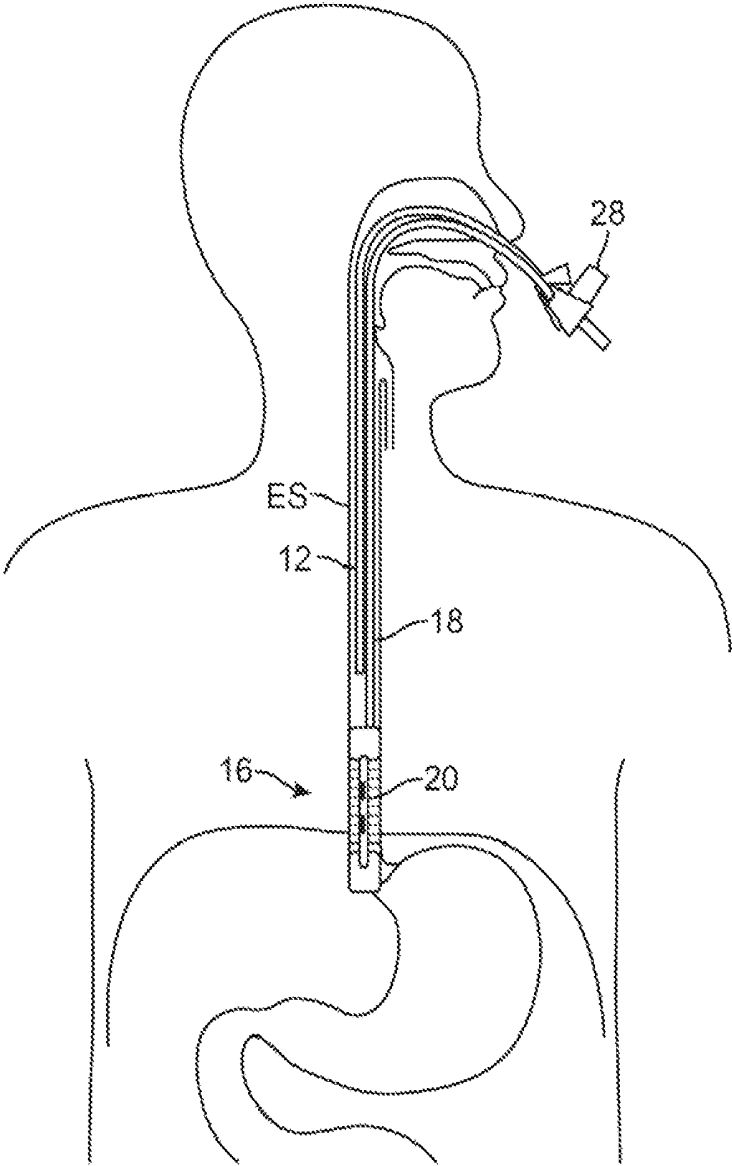

FIG. 5

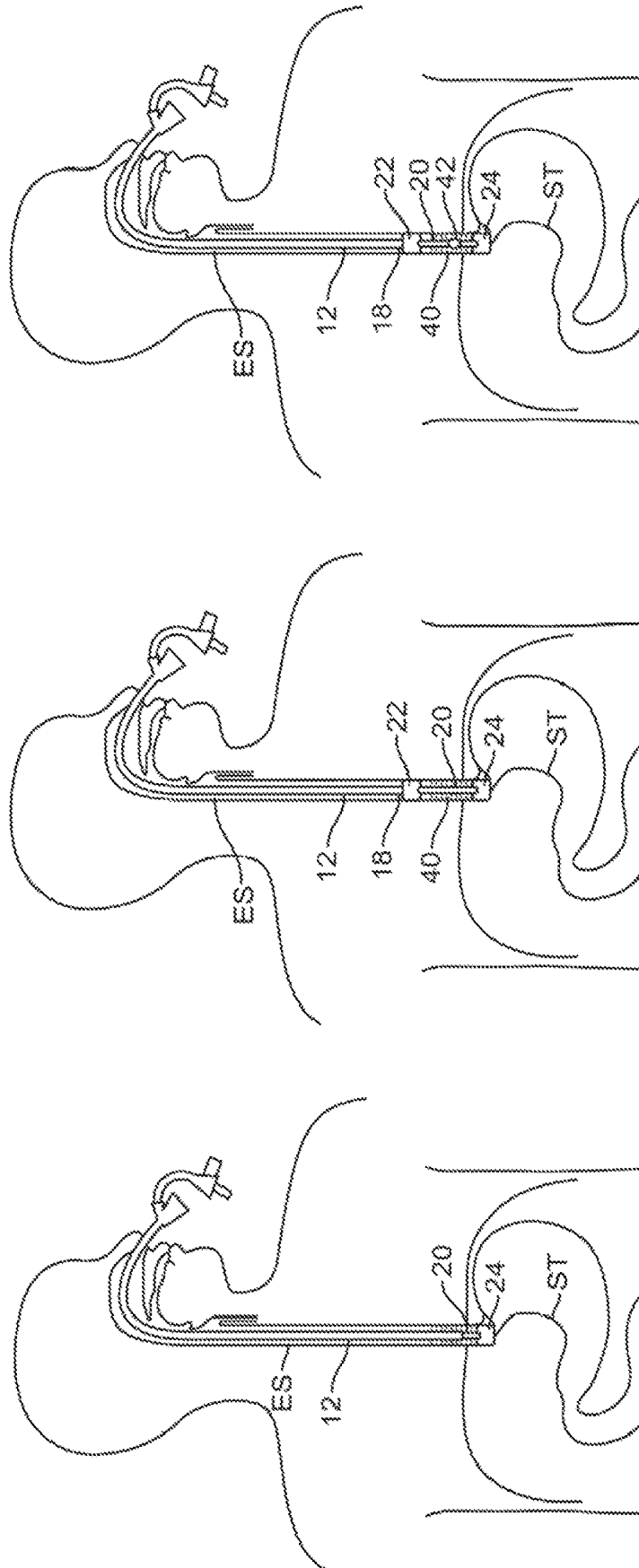

FIG. 6C

FIG. 6B

FIG. 6A

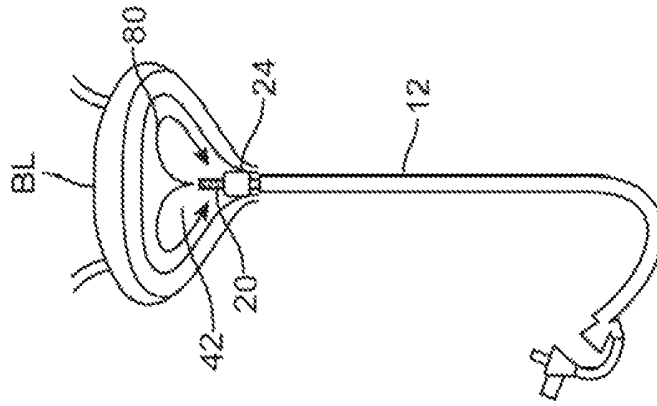

FIG. 7A

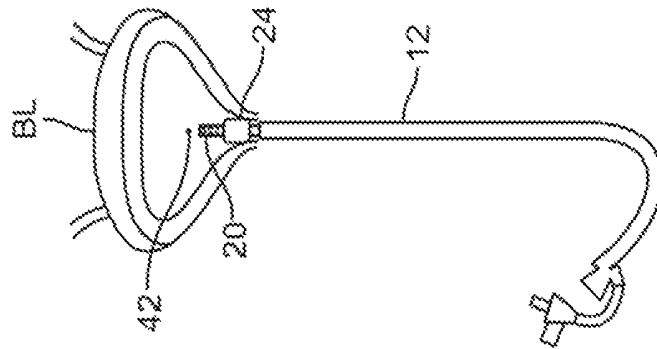

FIG. 7B

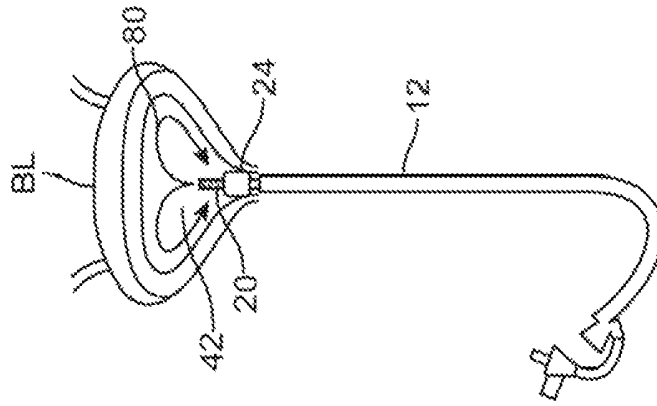

FIG. 7C

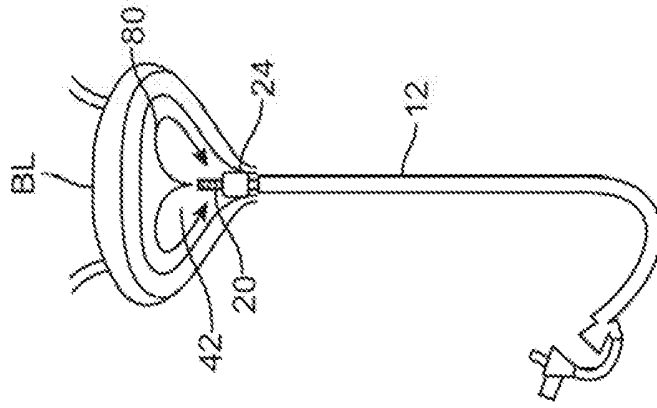

FIG. 8A

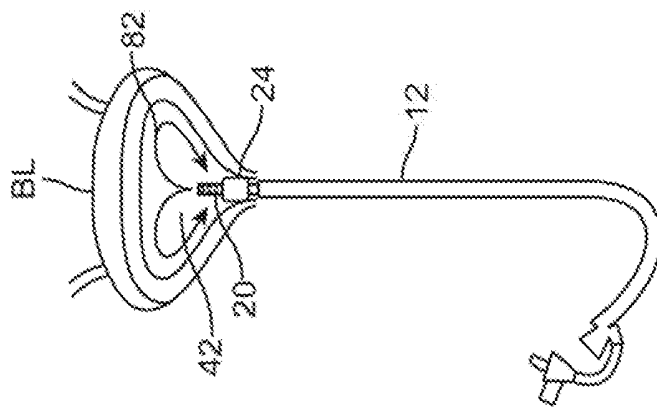

FIG. 8B

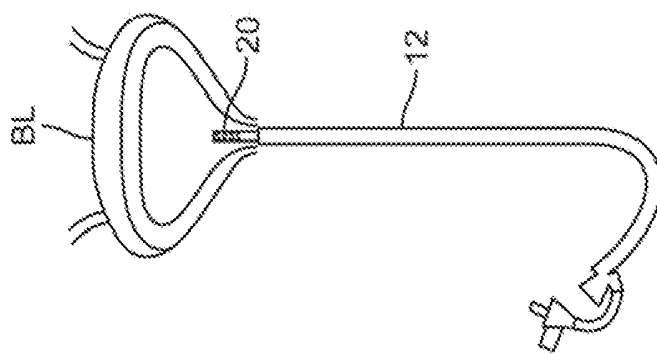

FIG. 8C

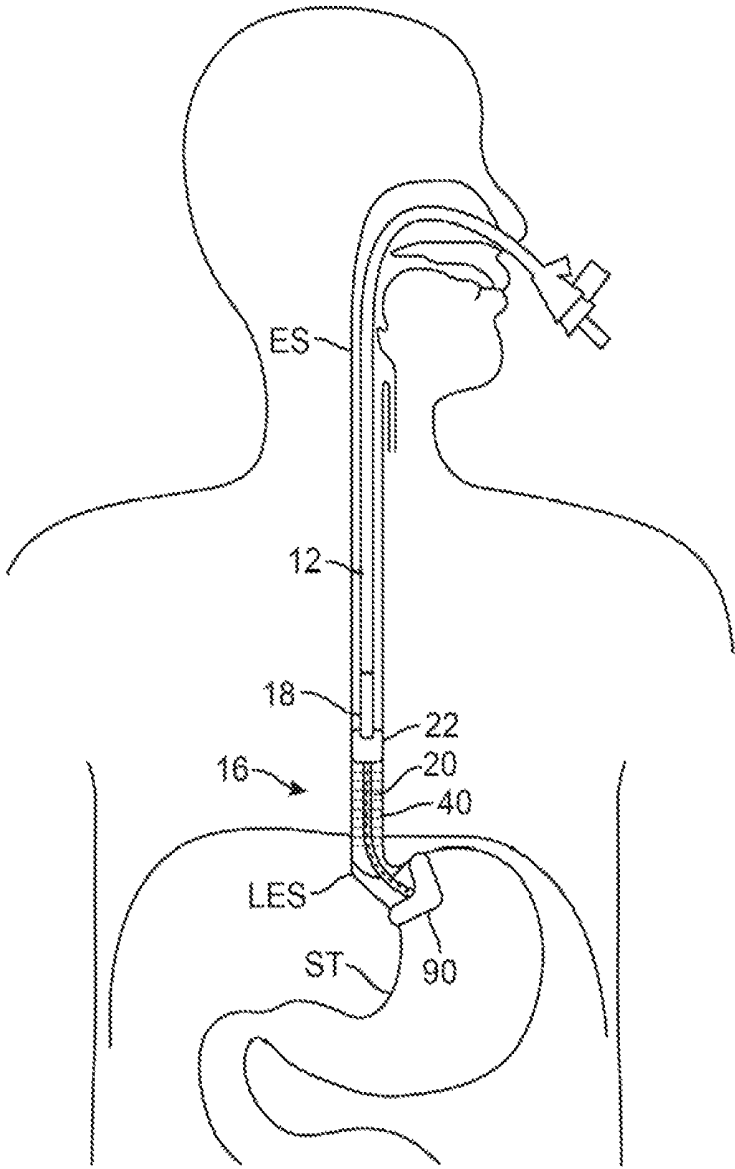

FIG. 9

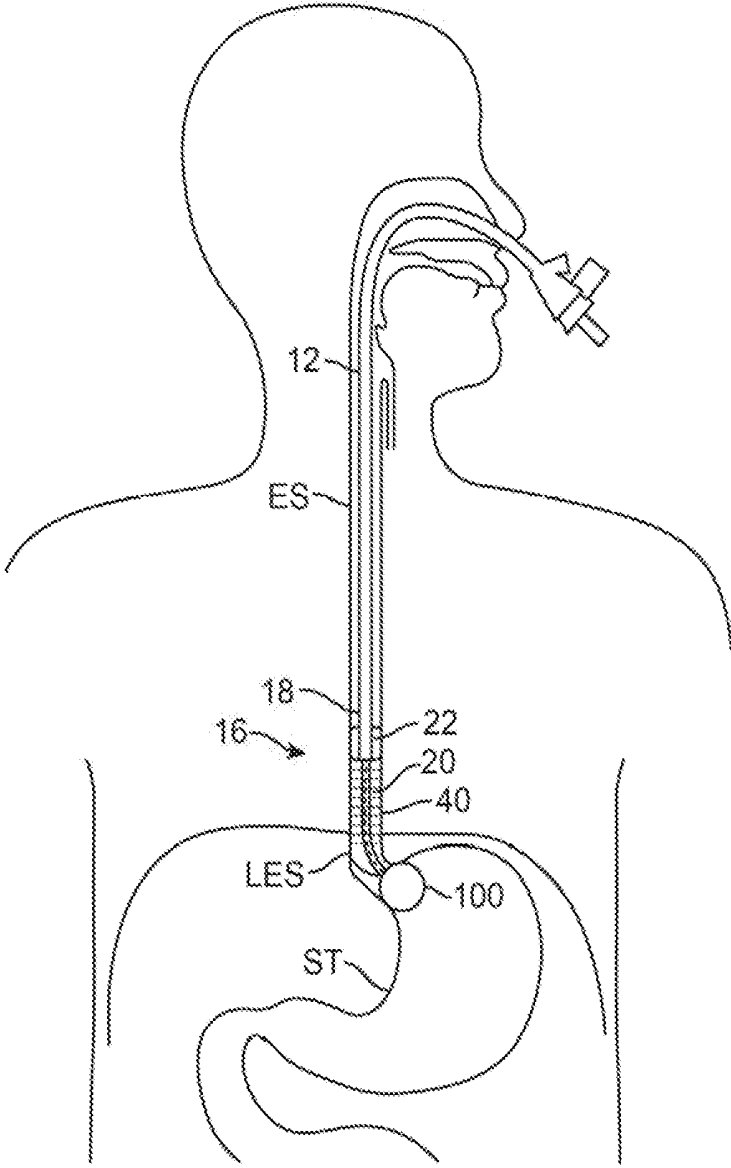

FIG. 10

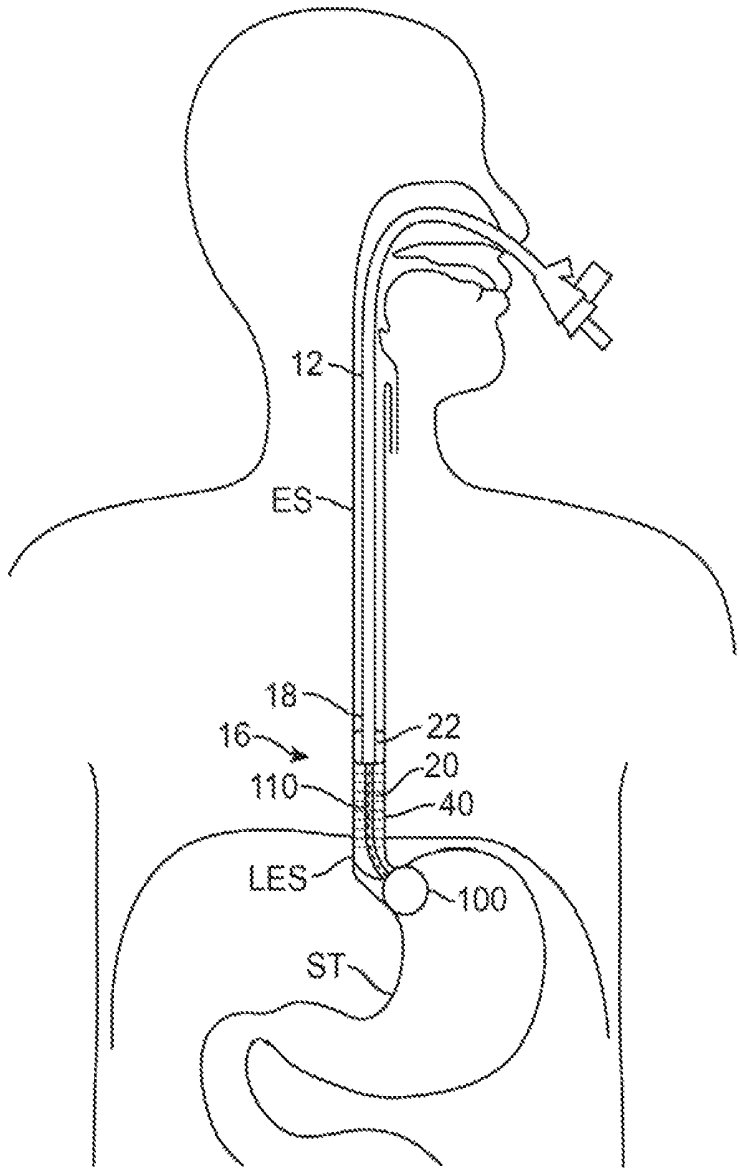

FIG. 11

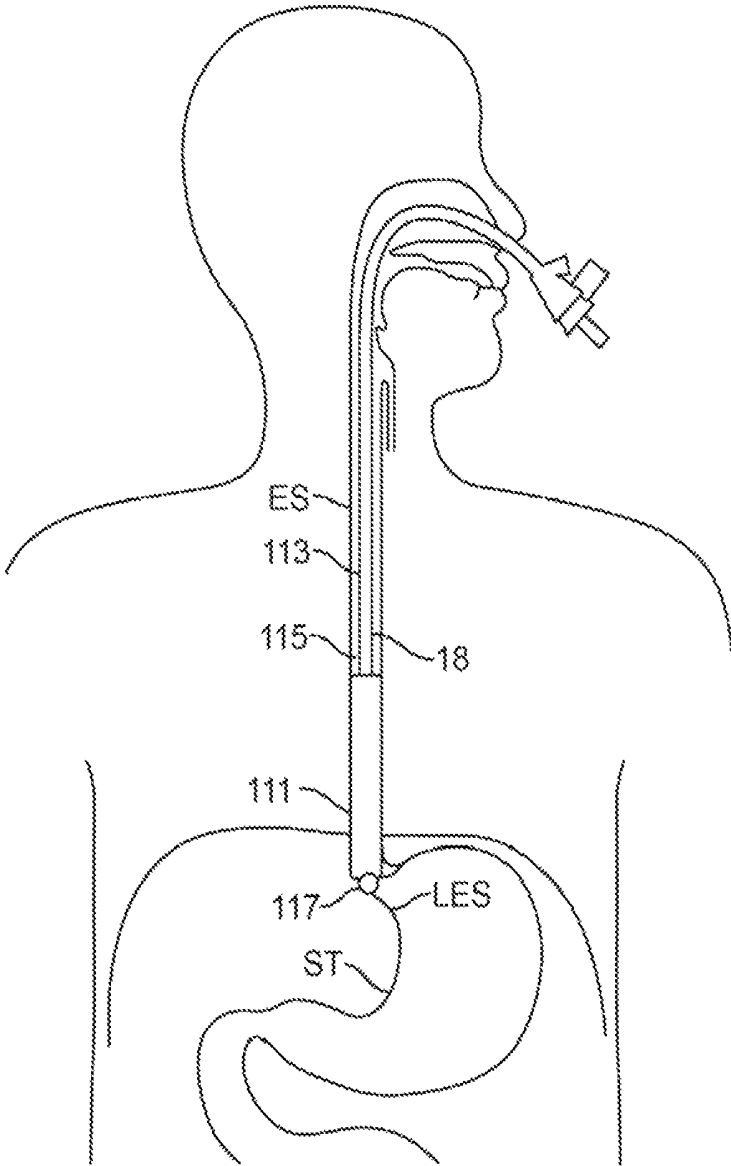

FIG. 12

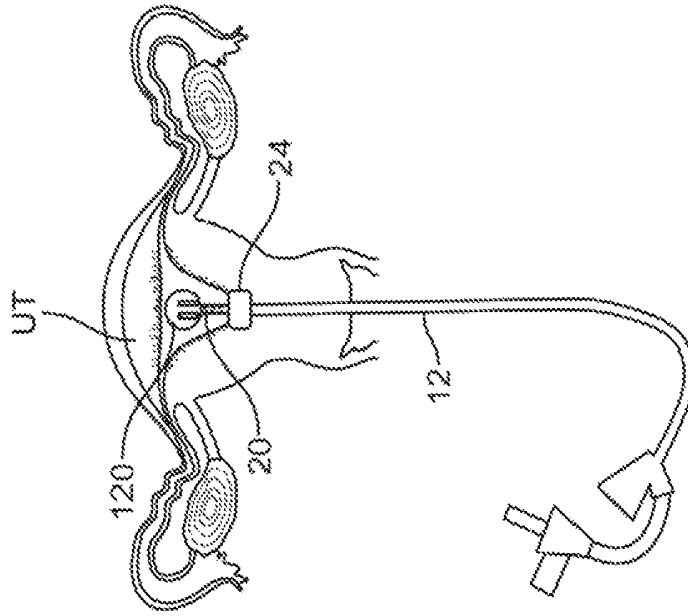

FIG. 13B

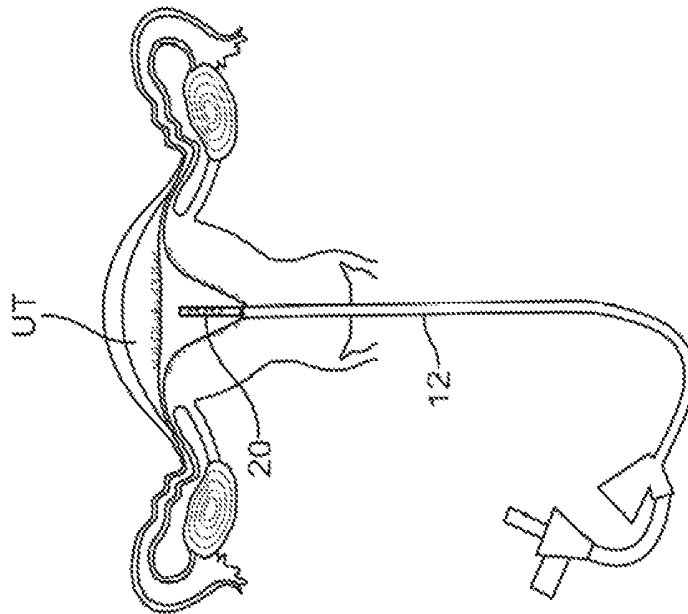

FIG. 13A

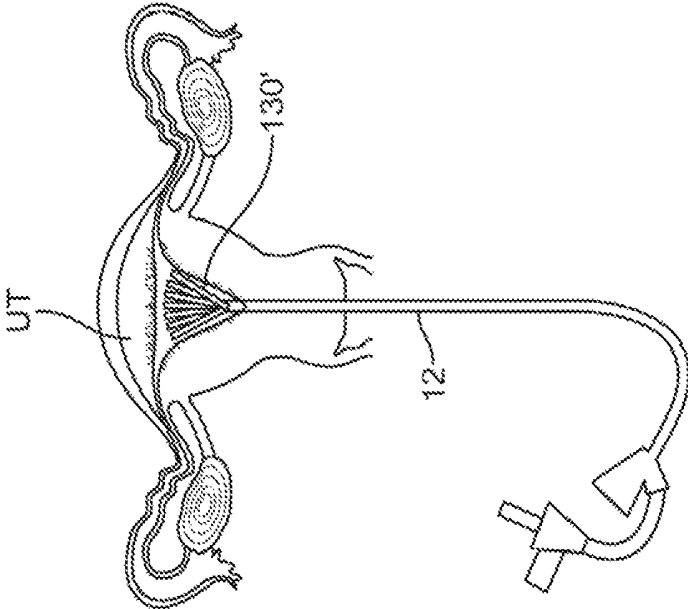

FIG. 14B

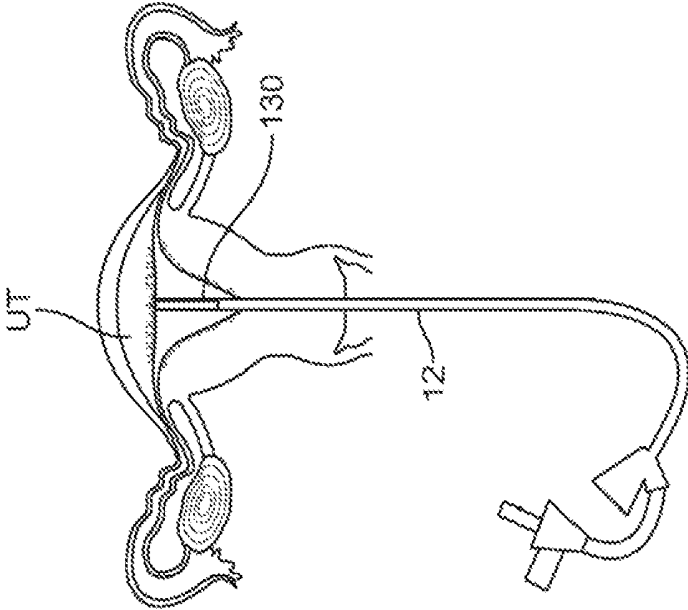

FIG. 14A

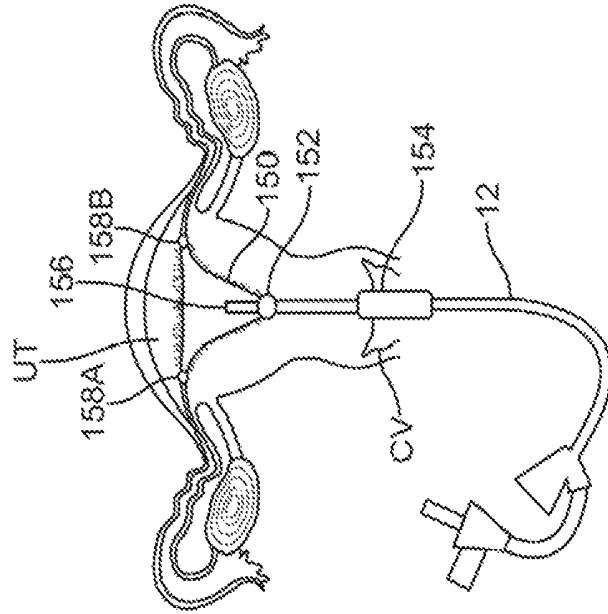

FIG. 15

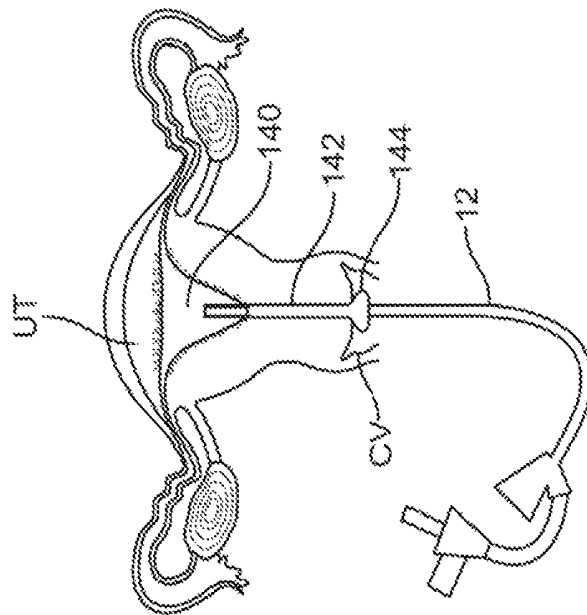

FIG. 16

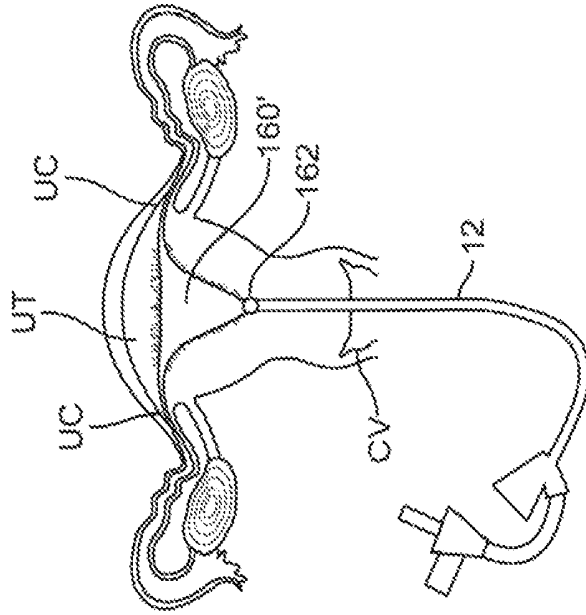

FIG. 17A

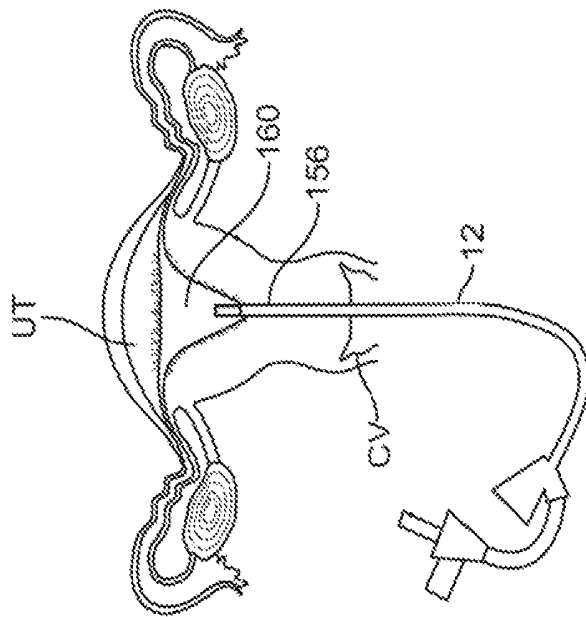

FIG. 17B

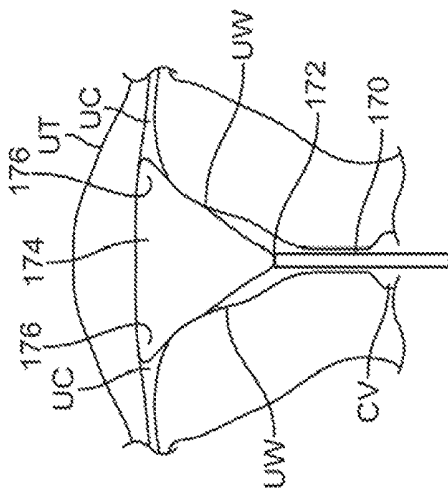

FIG. 18A

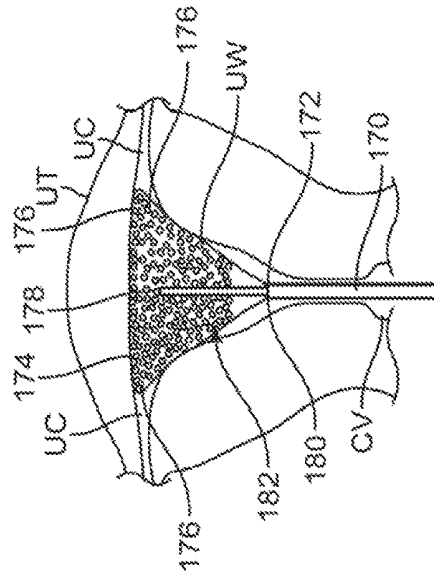

FIG. 18B

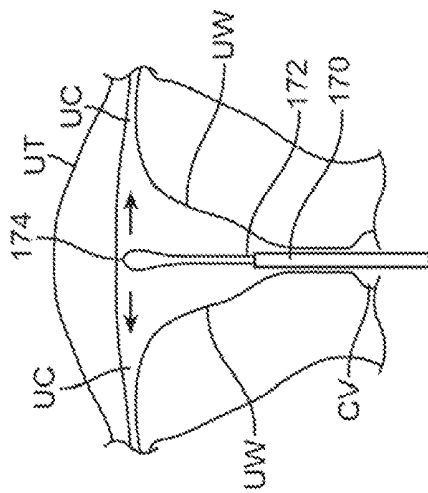

FIG. 18C

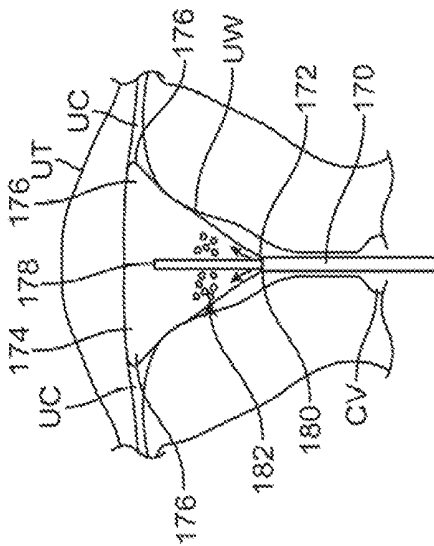

FIG. 18D

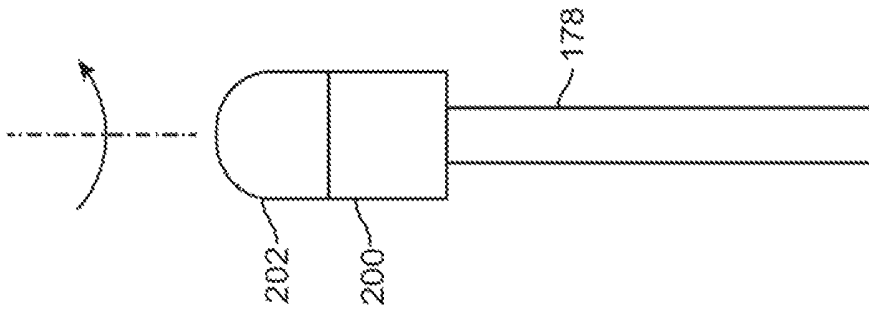

FIG. 20

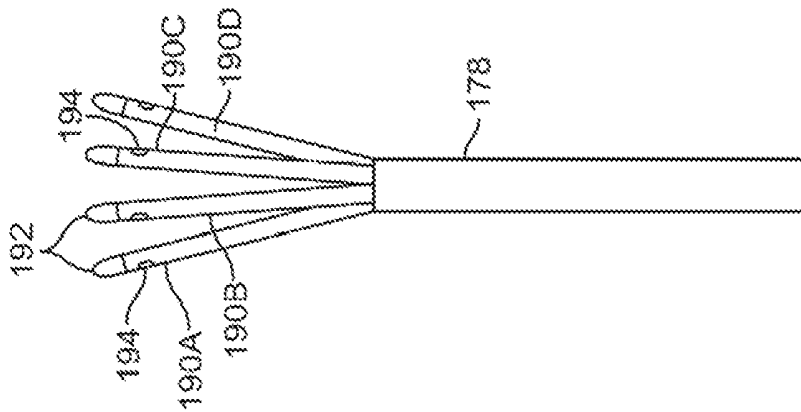
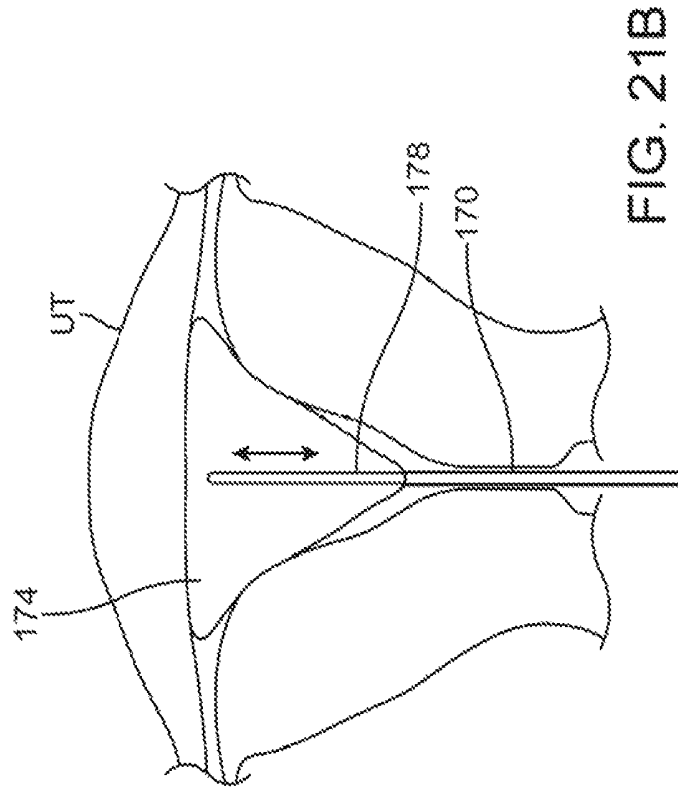
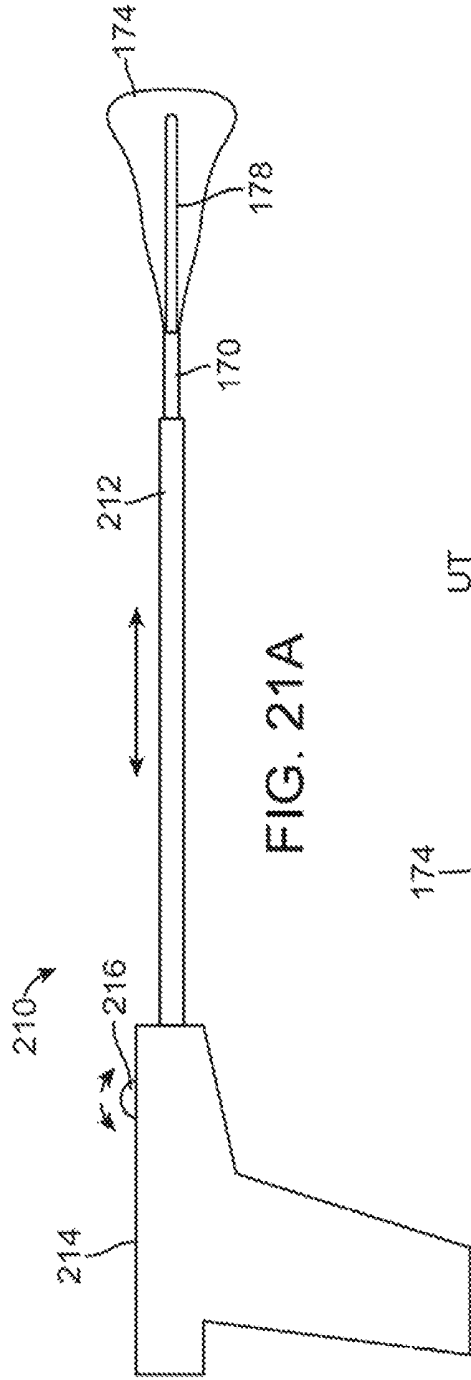

FIG. 19



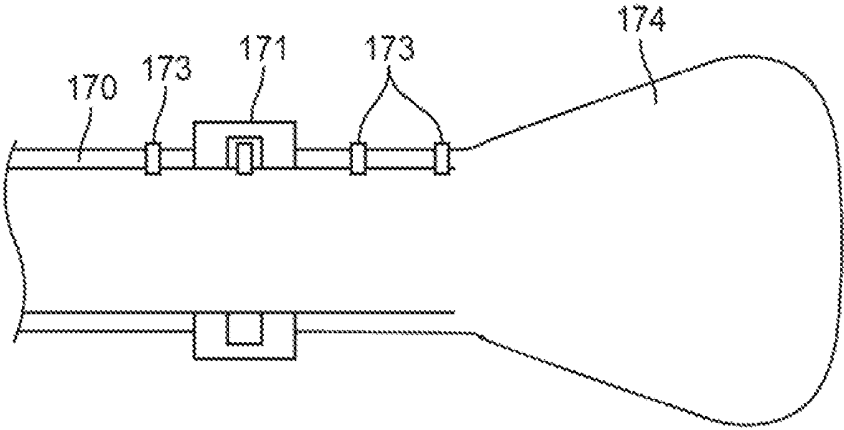

FIG. 22A

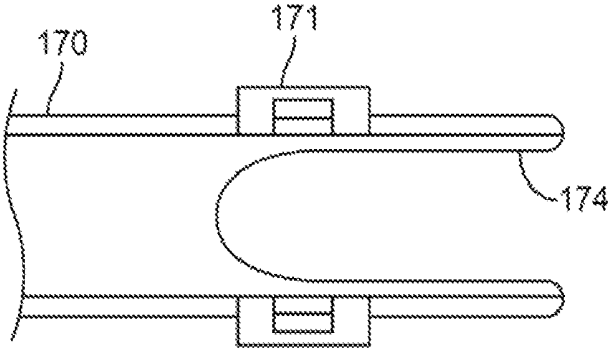

FIG. 22B

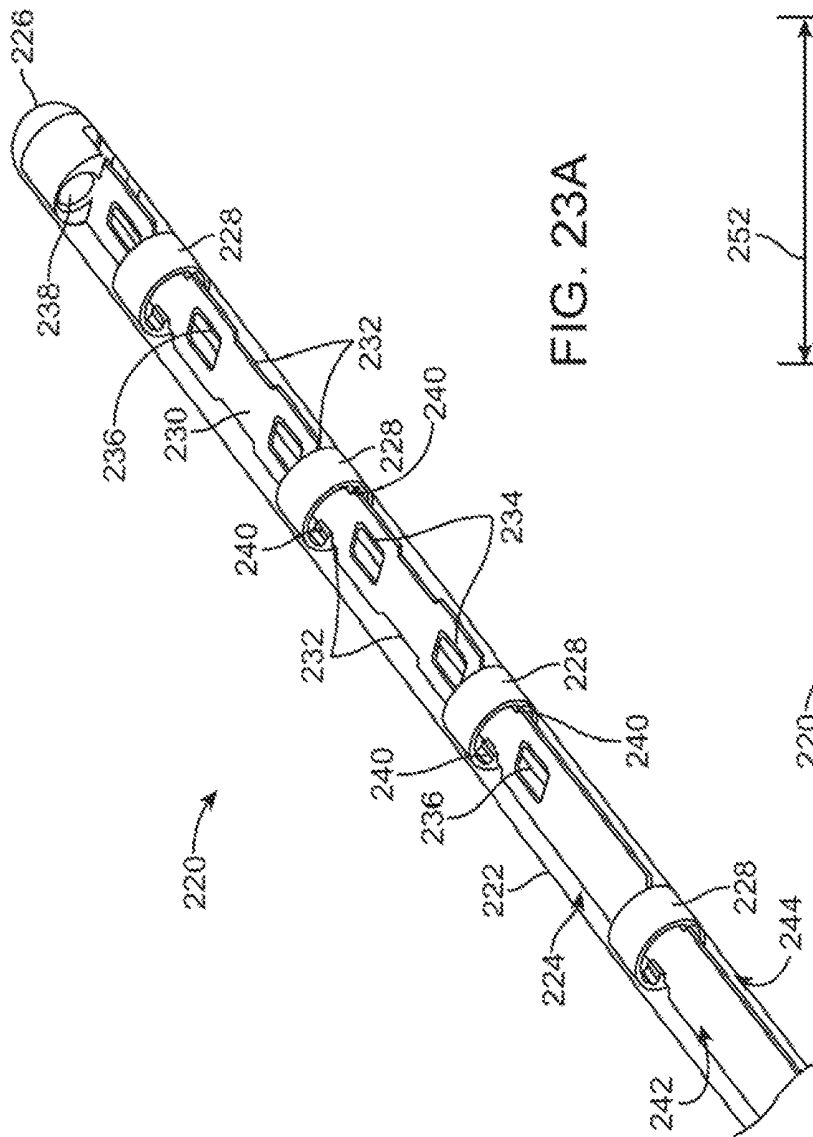

FIG. 23A

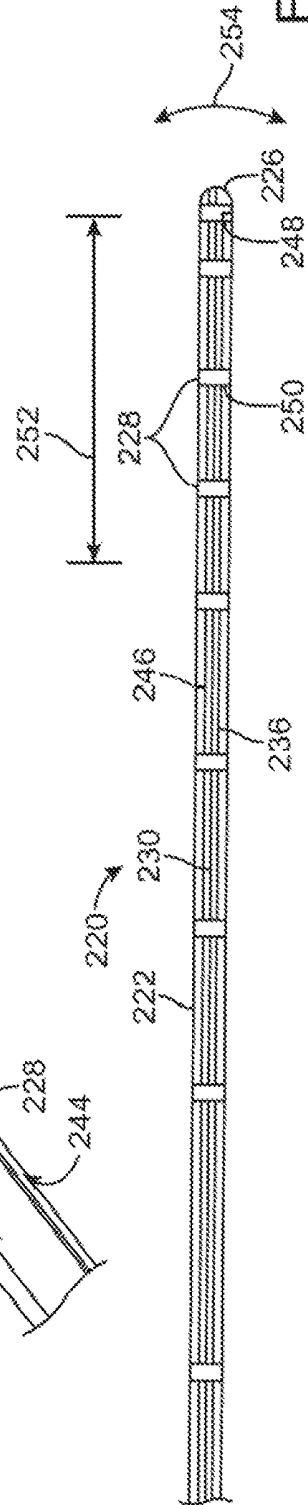

FIG. 23B

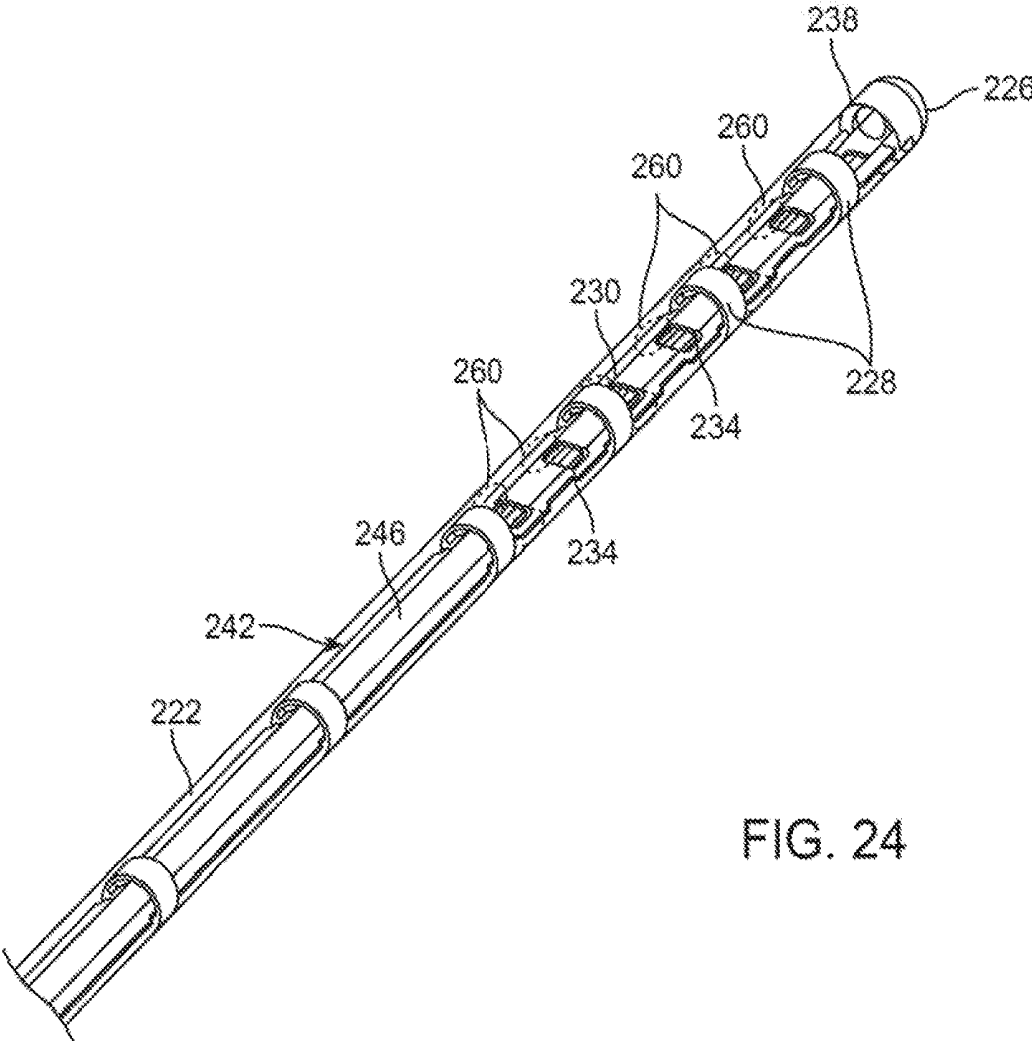

FIG. 24

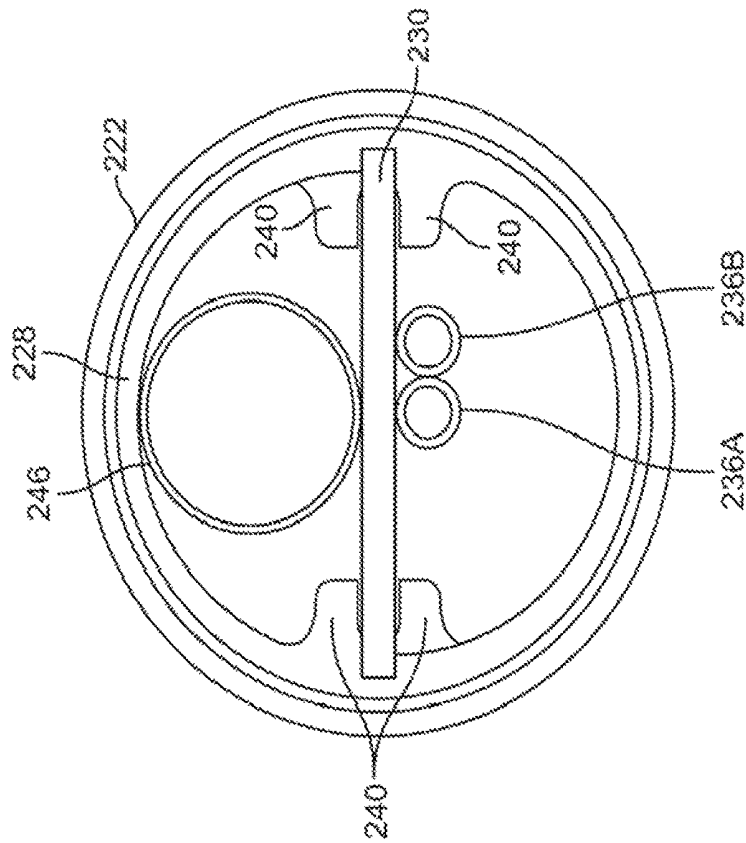

FIG. 25A

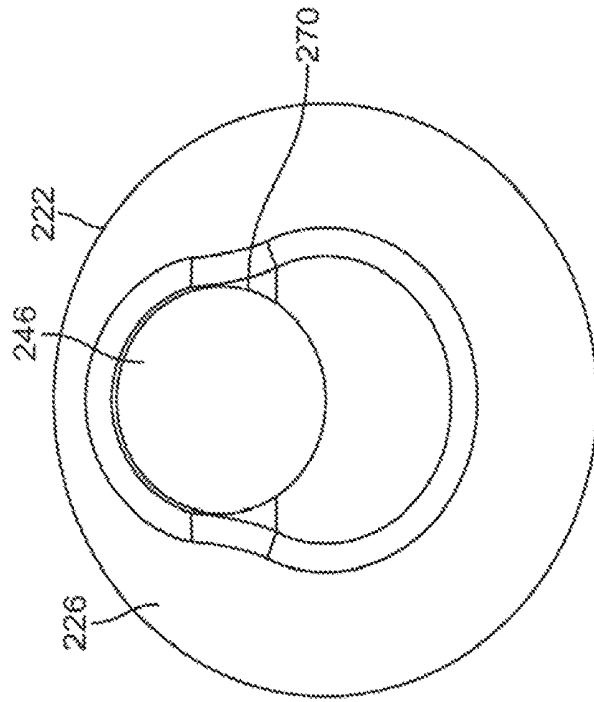

FIG. 25B

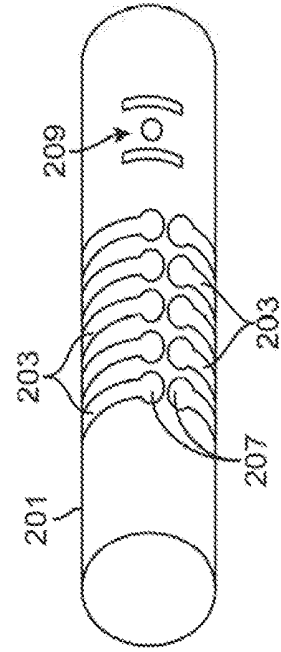

FIG. 26A

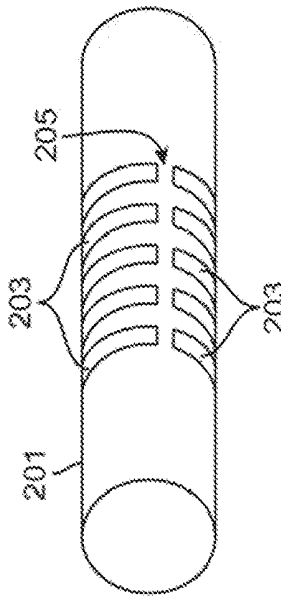

FIG. 26B

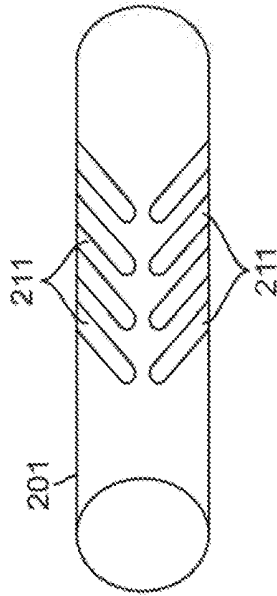

FIG. 26C

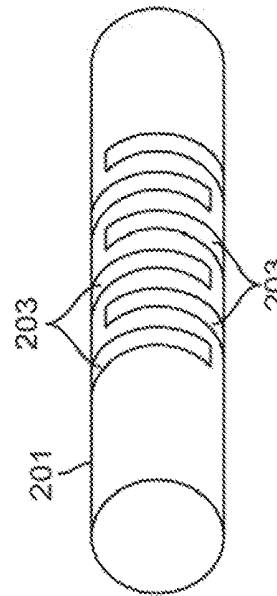

FIG. 26D

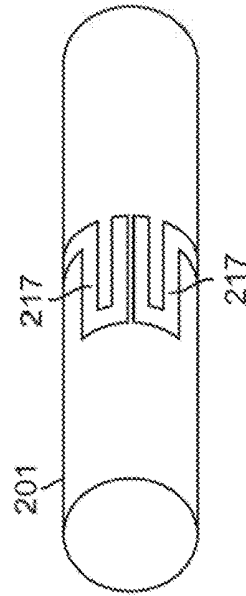

FIG. 26E

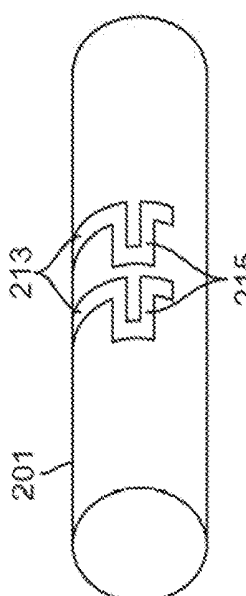

FIG. 26F

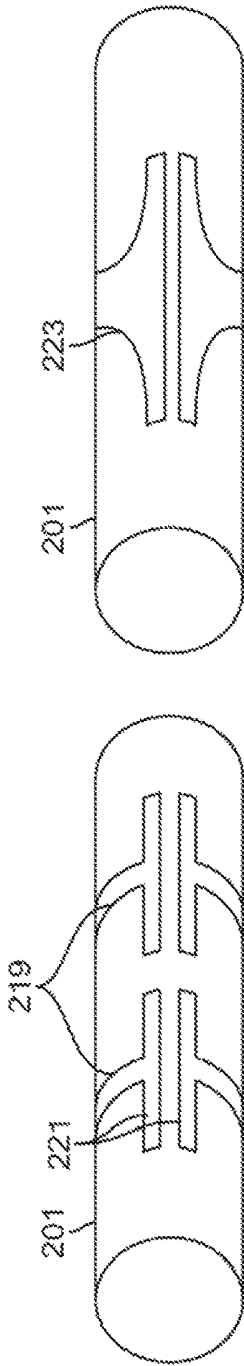

FIG. 26G

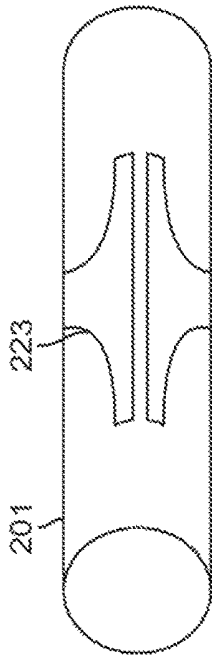

FIG. 26H

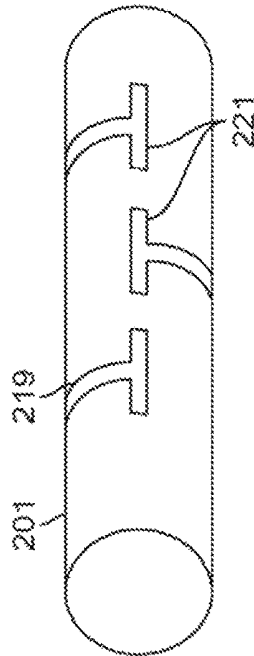

FIG. 26I

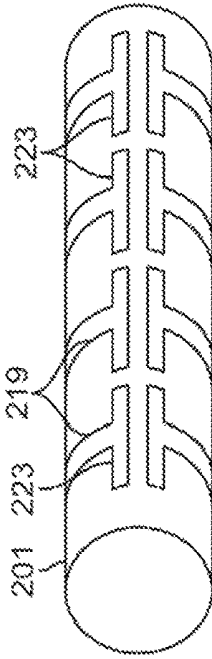

FIG. 26J

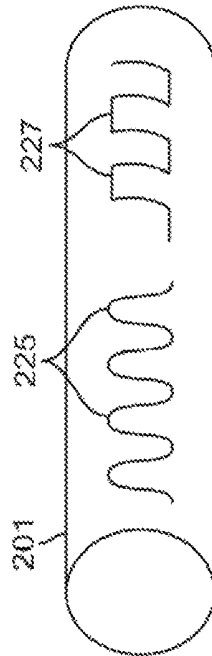

FIG. 26K

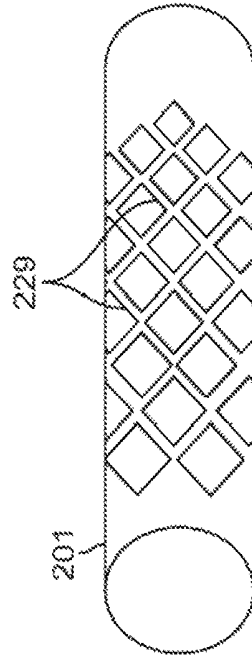

FIG. 26L

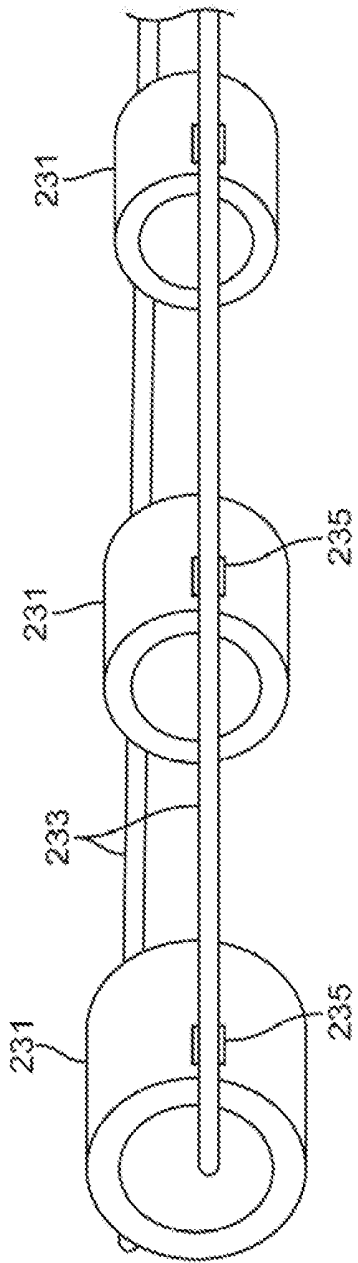

FIG. 27A

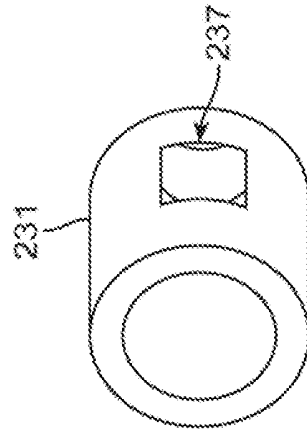

FIG. 27B

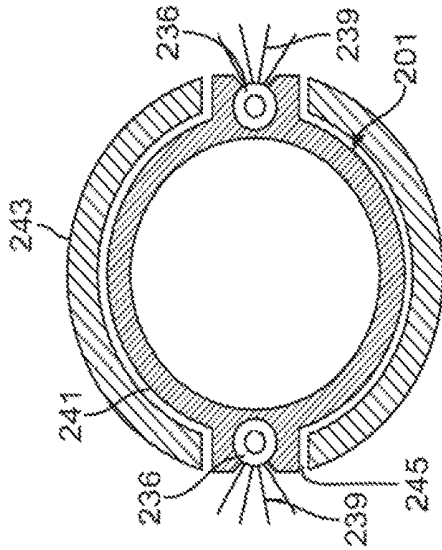

FIG. 28B

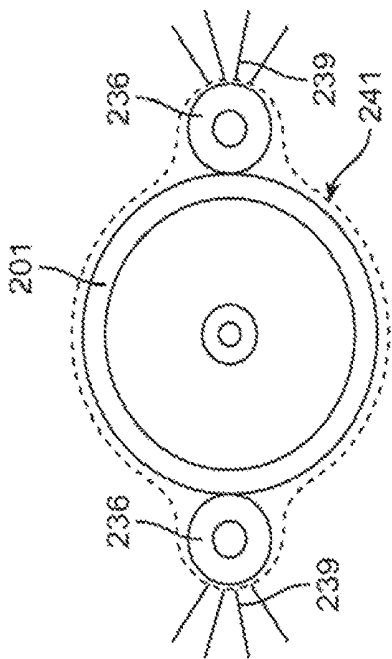

FIG. 28A

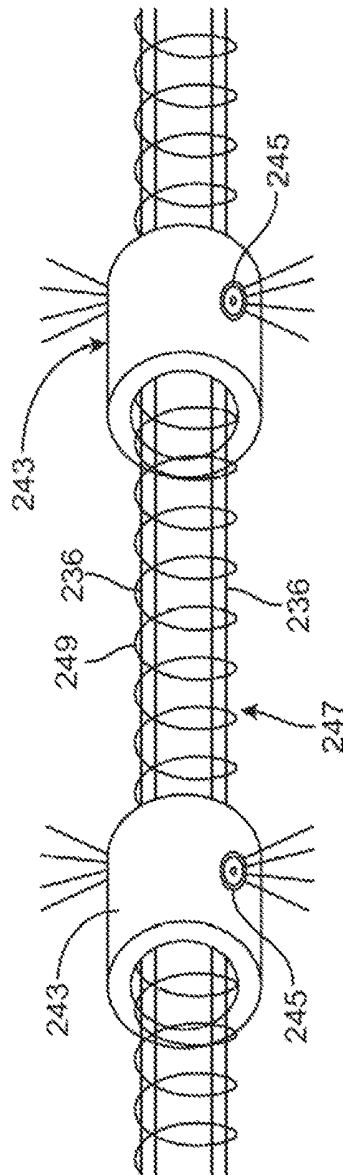

FIG. 29

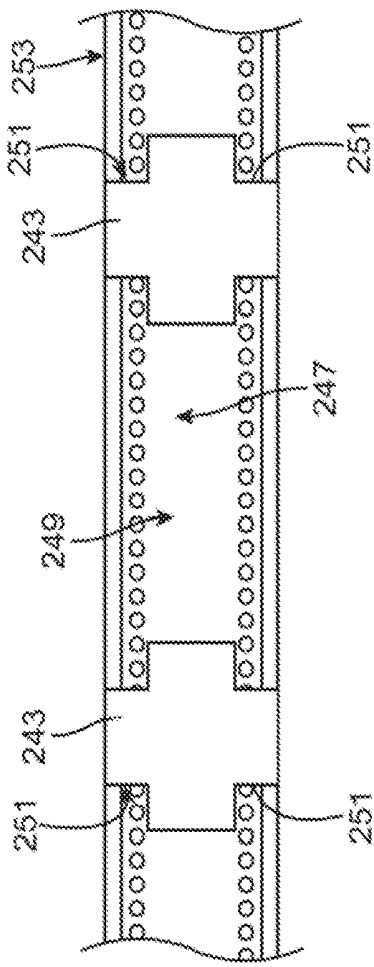

FIG. 30A

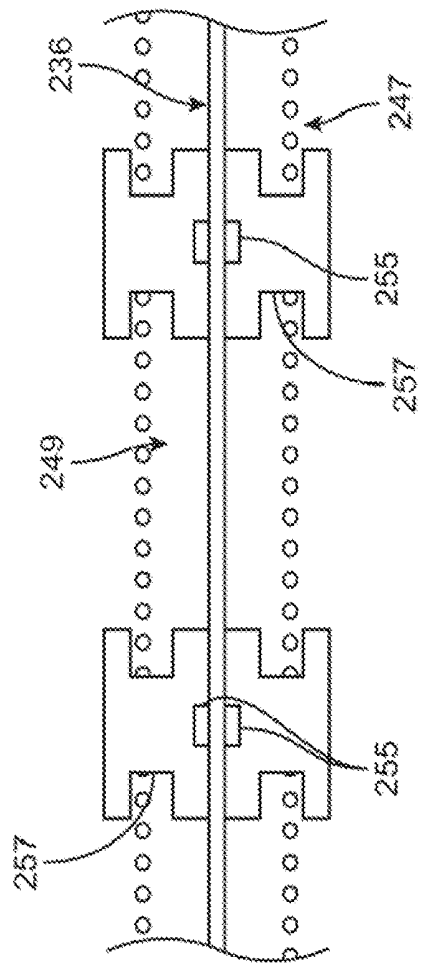
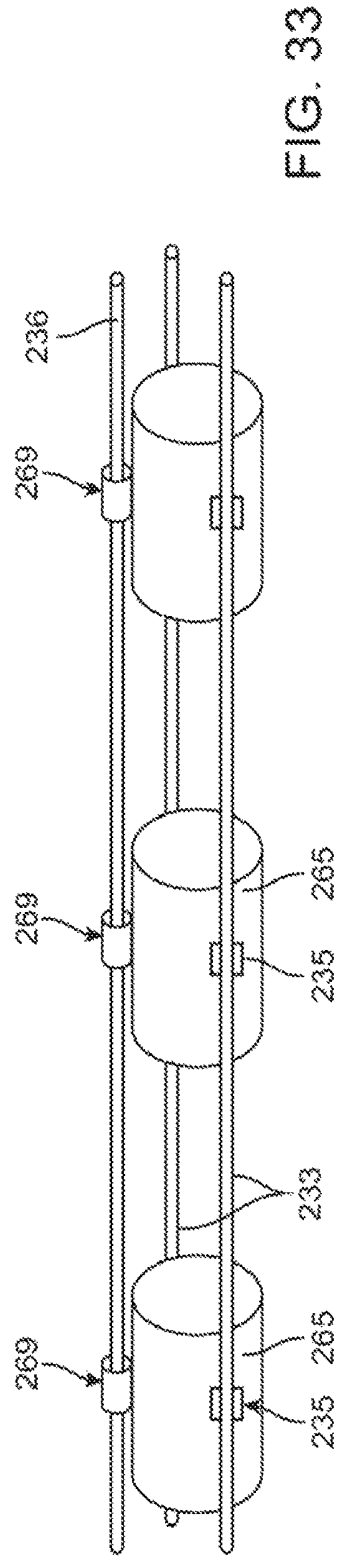
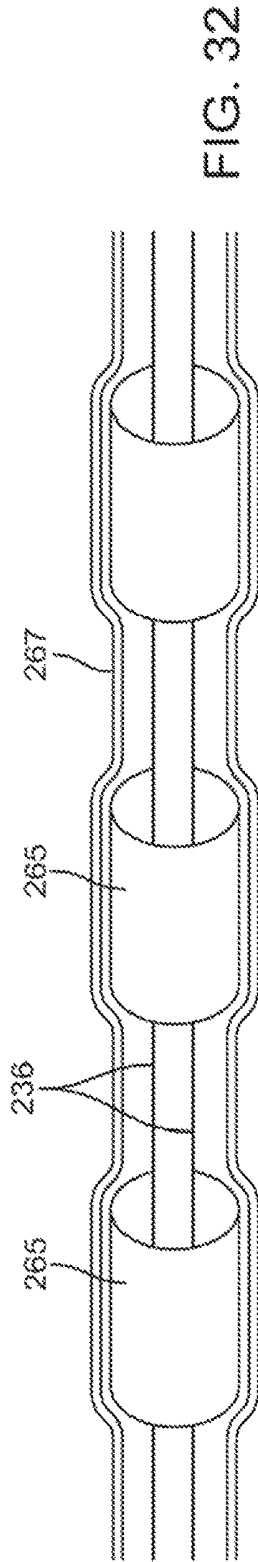
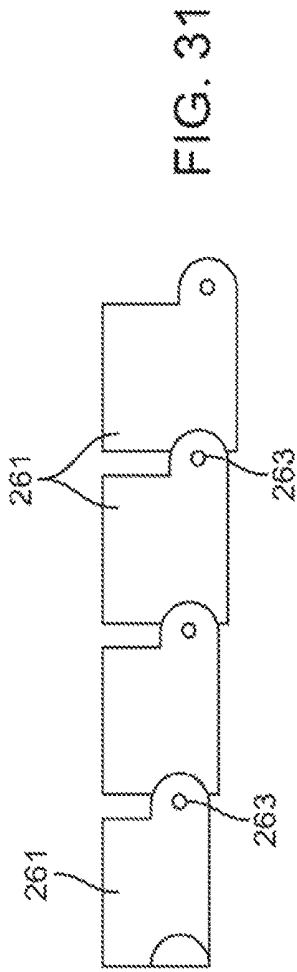
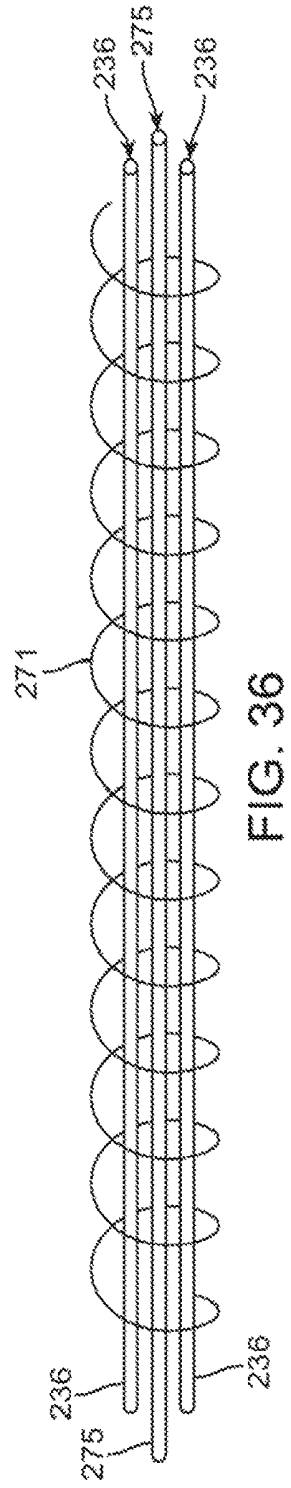
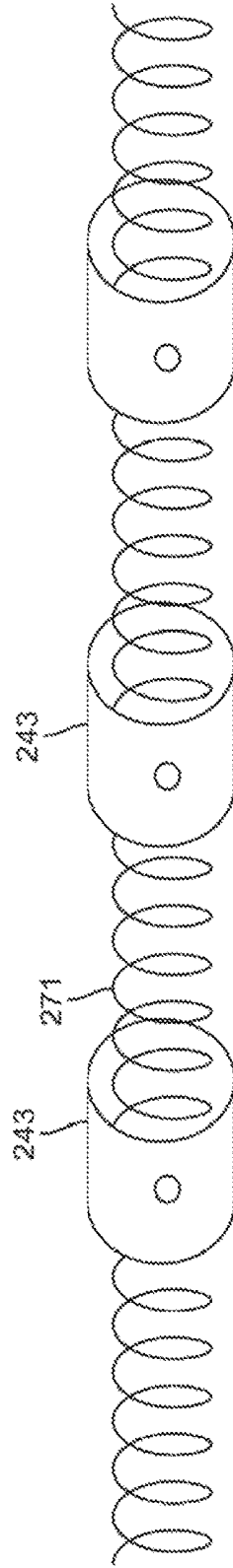
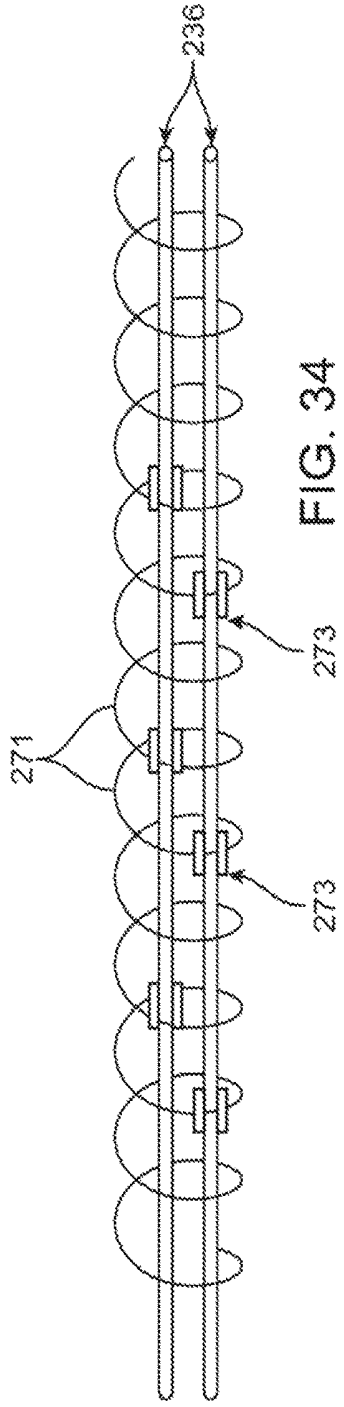

FIG. 30B





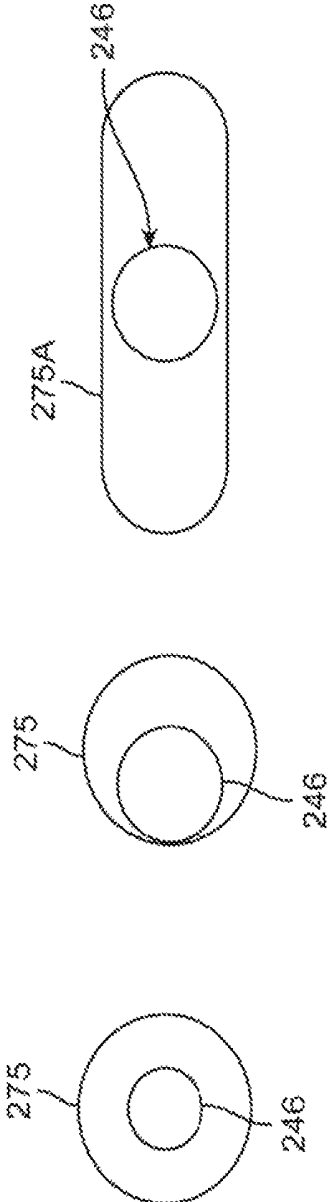

FIG. 37

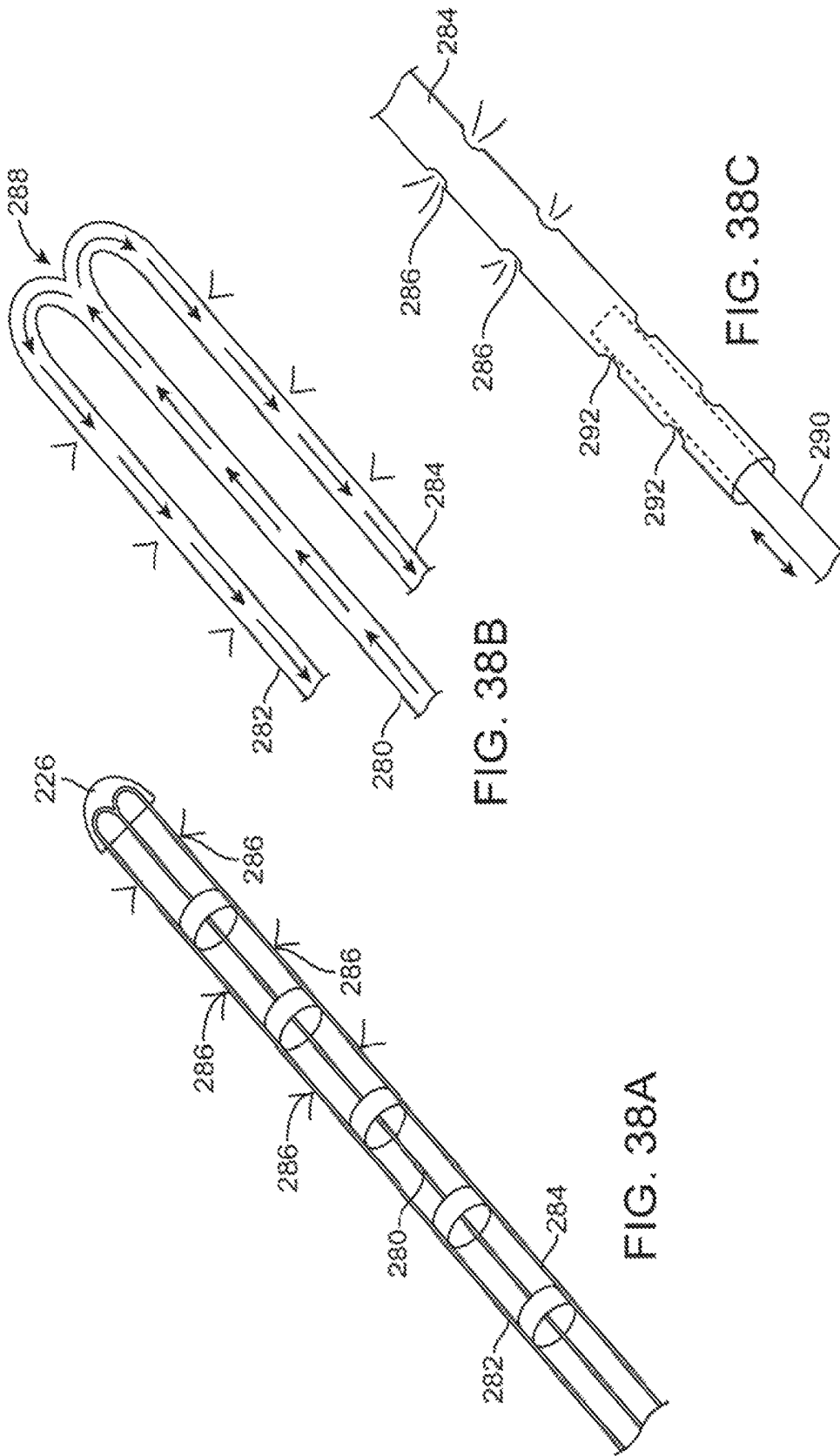

FIG. 38B

FIG. 38A

FIG. 38C

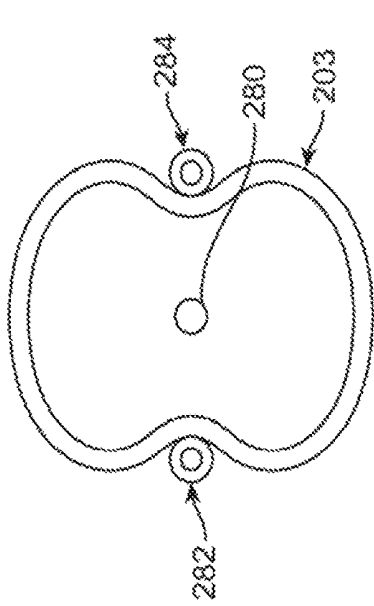

FIG. 40A

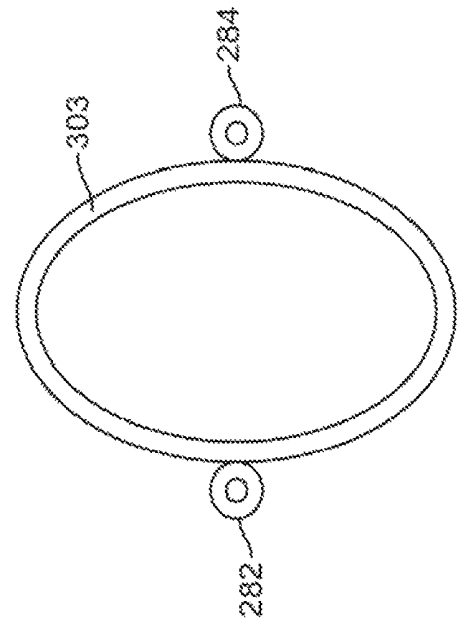

FIG. 40B

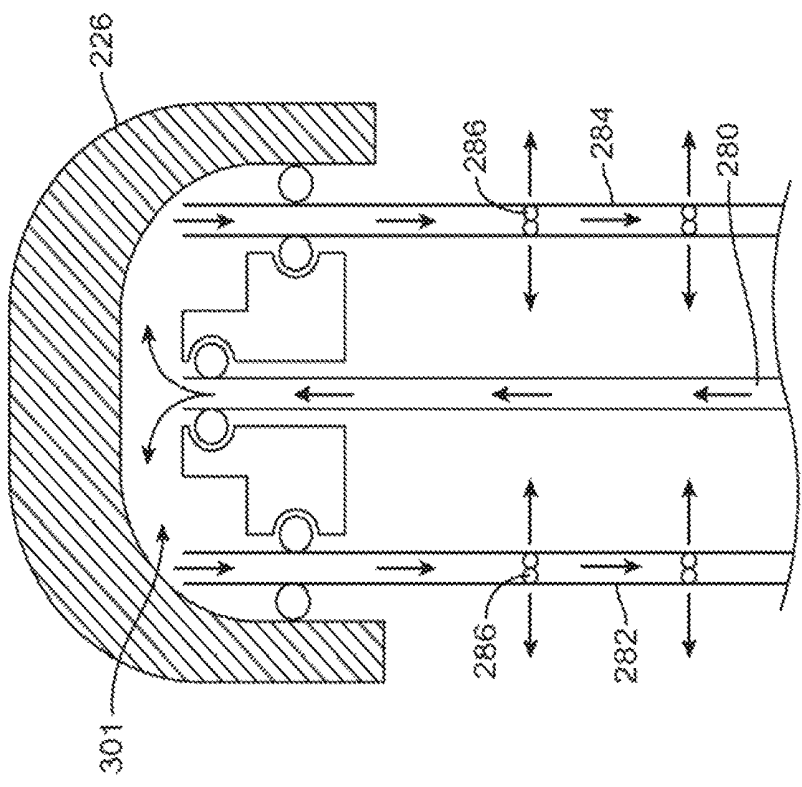

FIG. 39

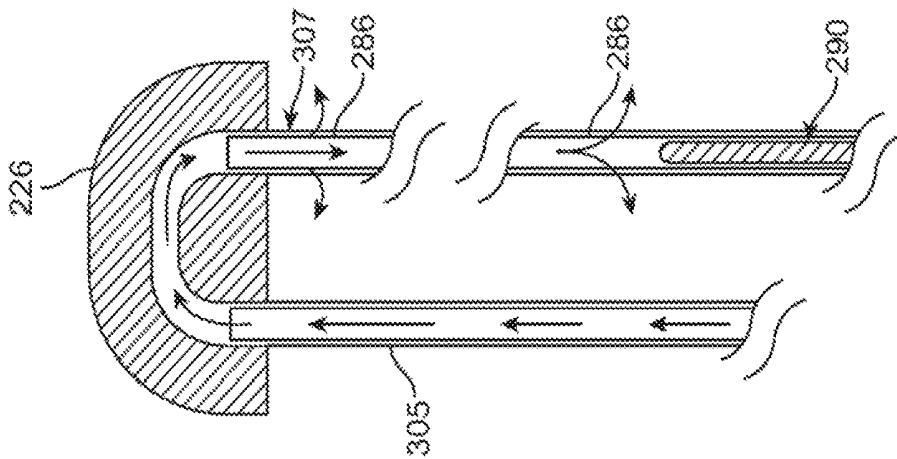

FIG. 41

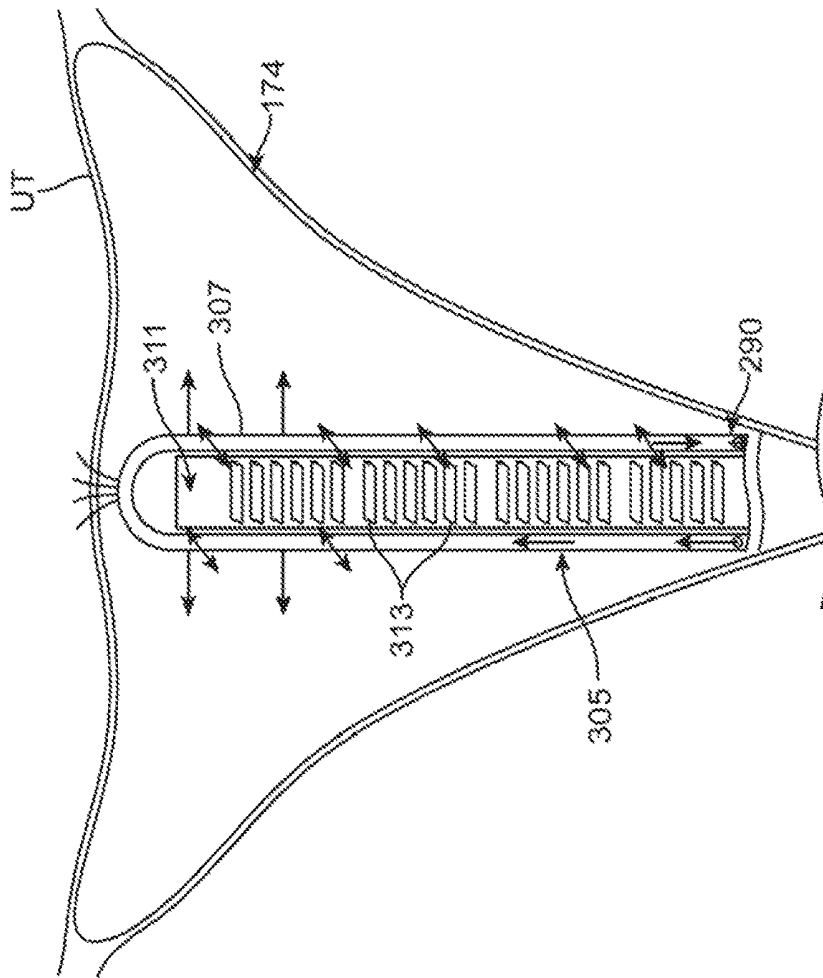

FIG. 42

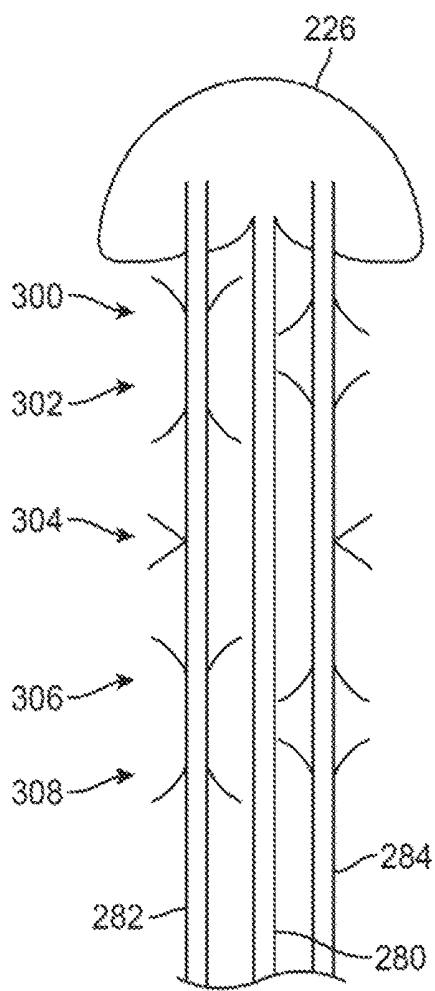

FIG. 43A

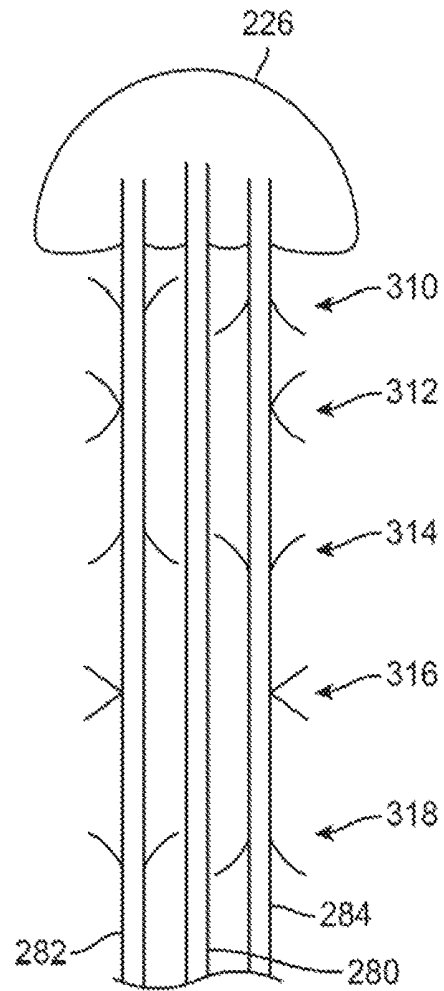

FIG. 43B

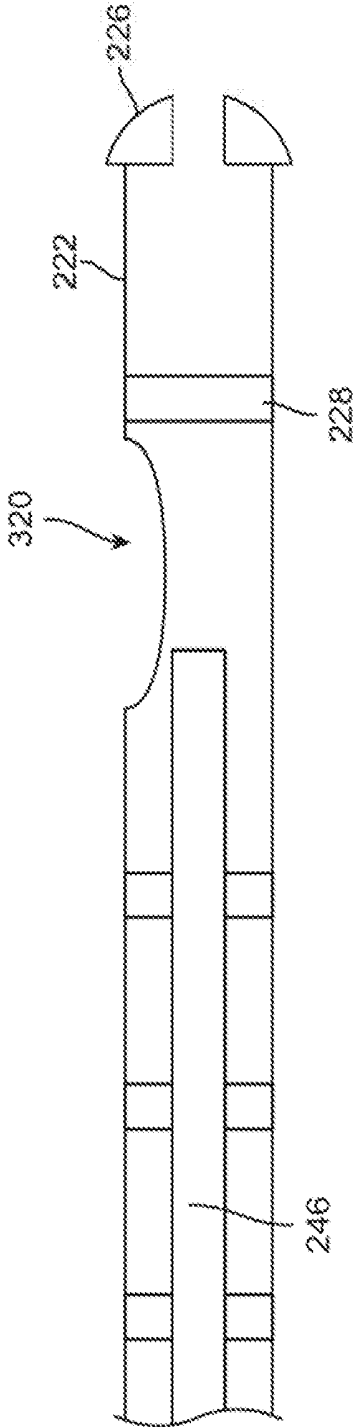

FIG. 44

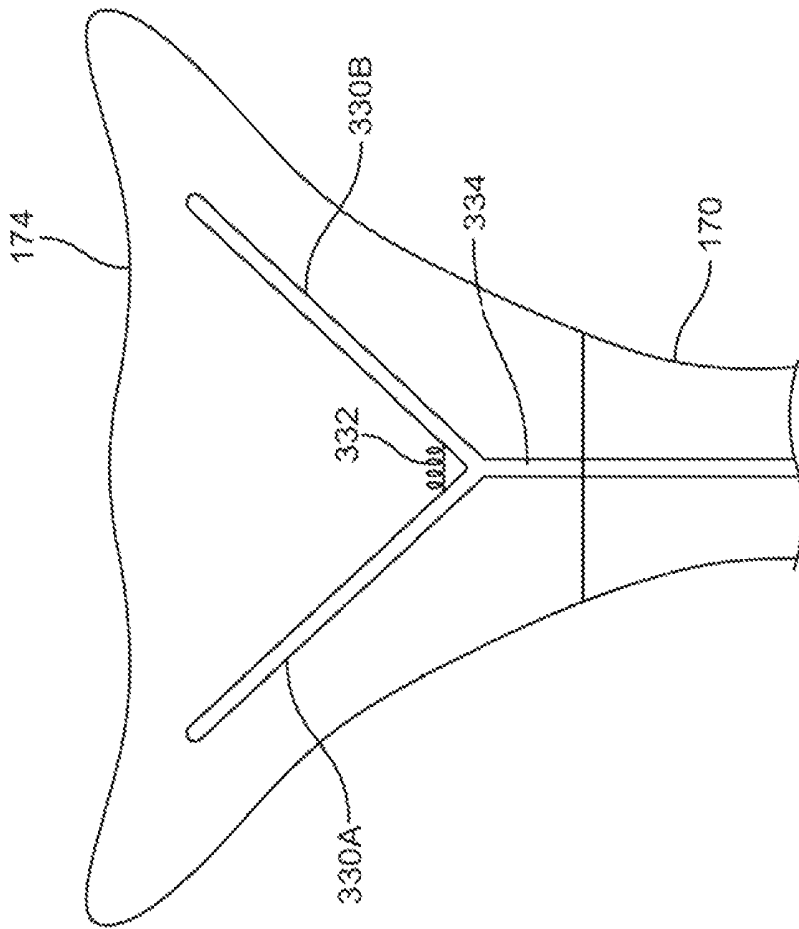

FIG. 45

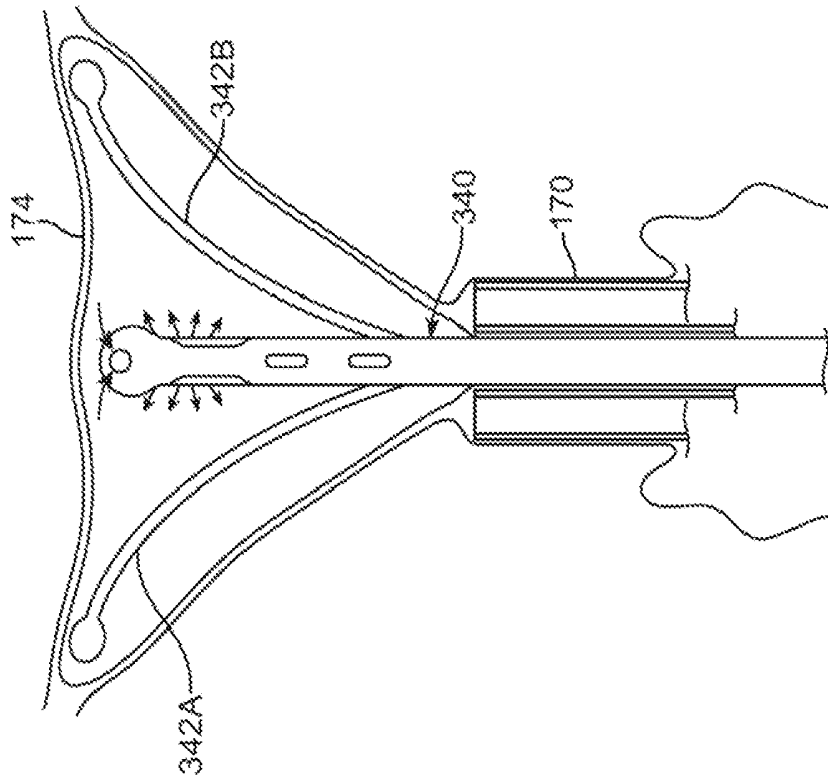

FIG. 46

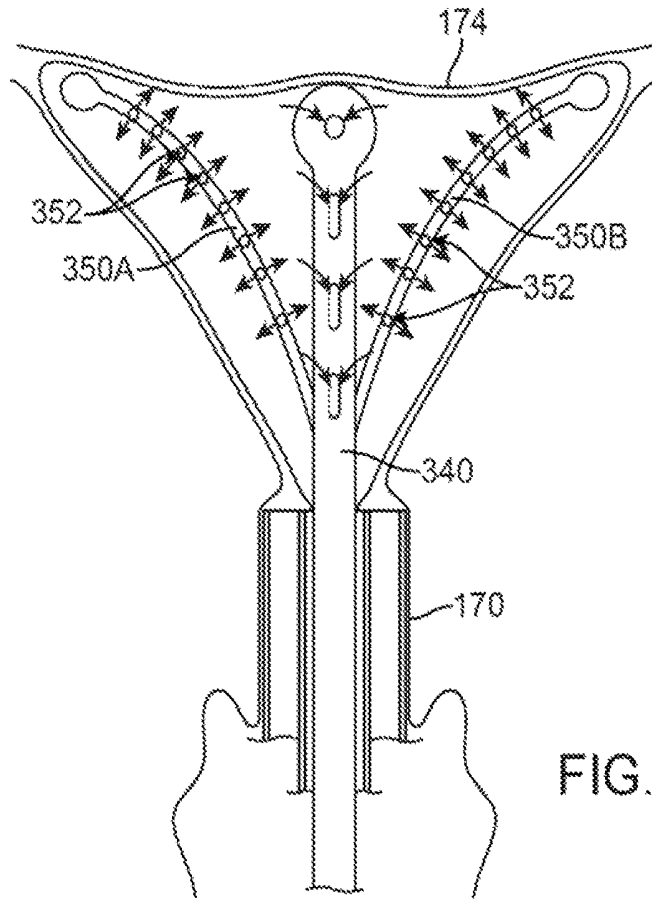

FIG. 47

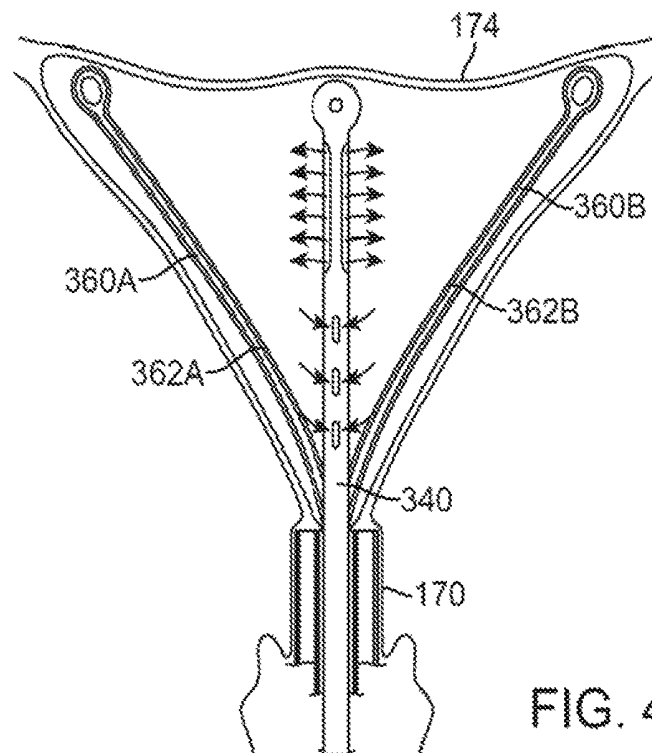

FIG. 48

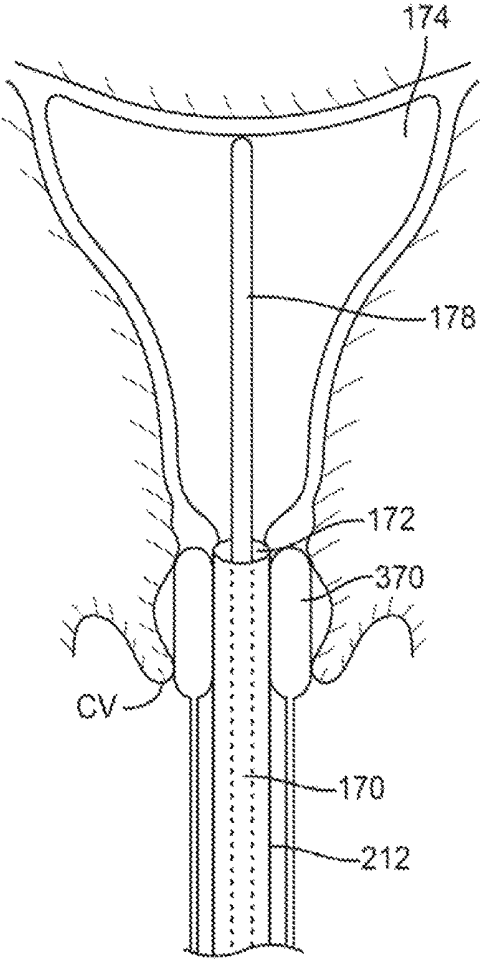

FIG. 49

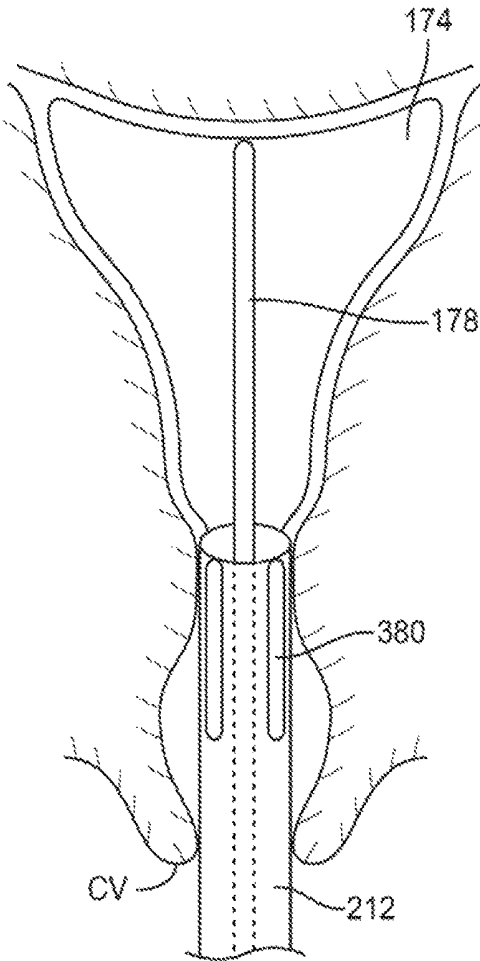

FIG. 50

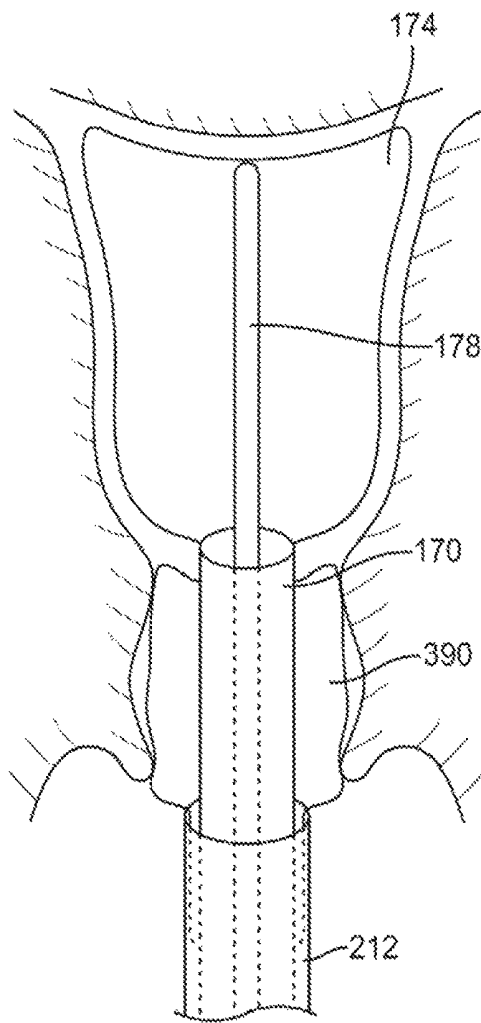

FIG. 51

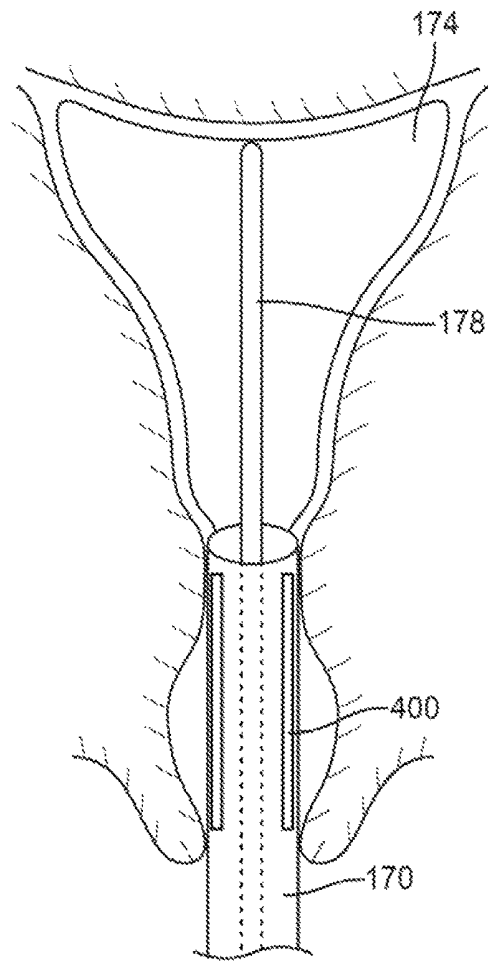

FIG. 52

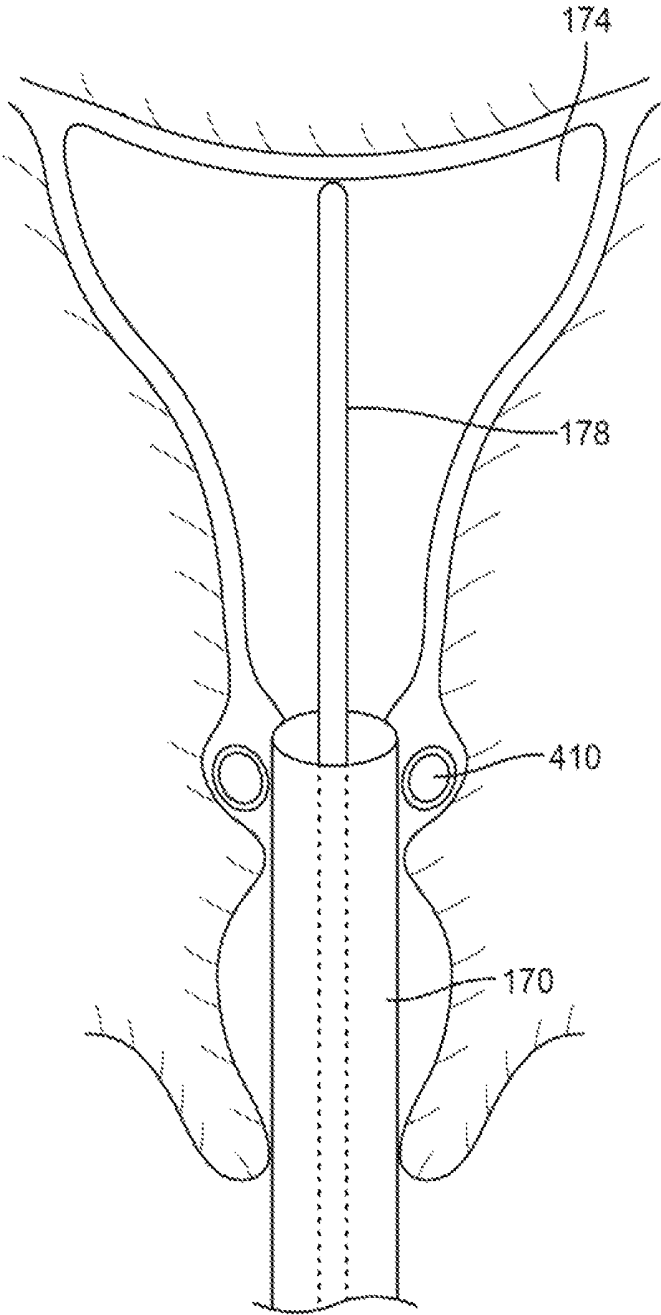

FIG. 53

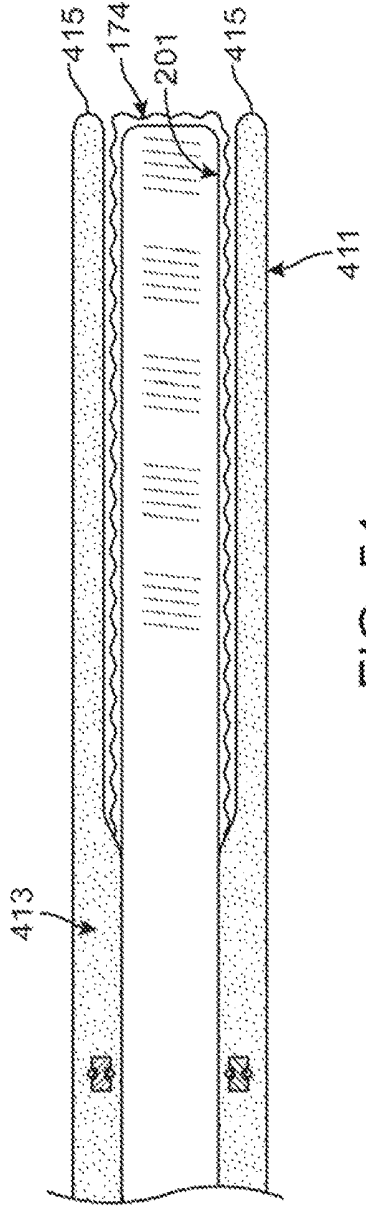

FIG. 54

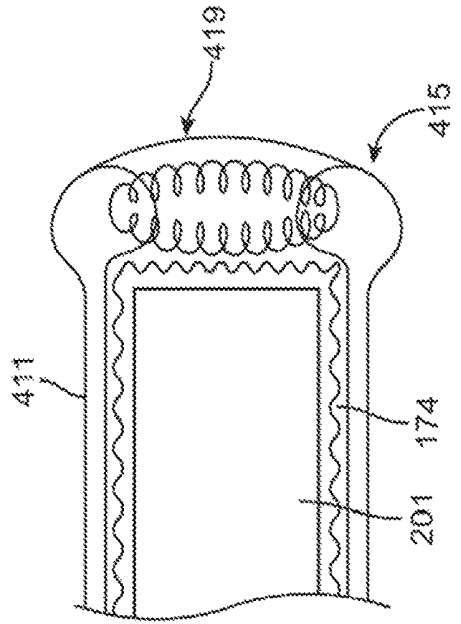

FIG. 55B

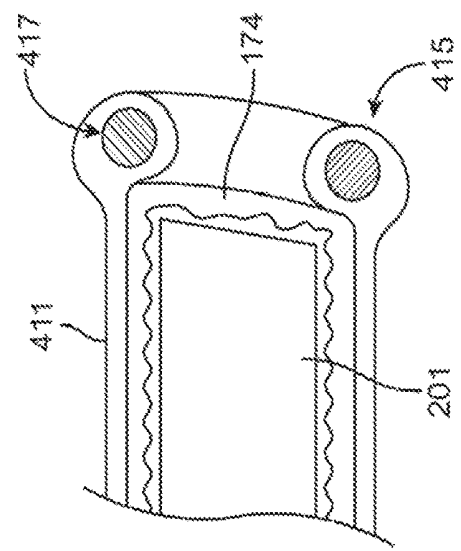

FIG. 55A

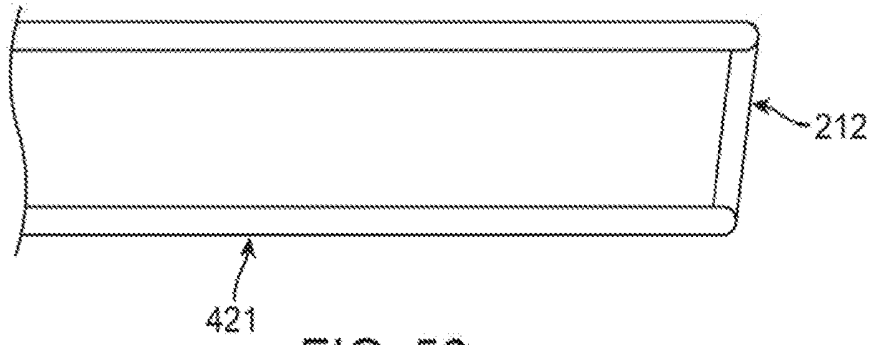

FIG. 56

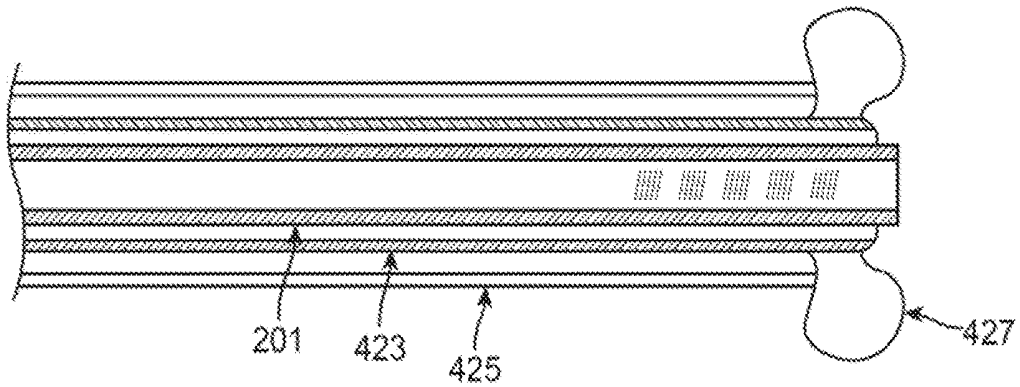

FIG. 57

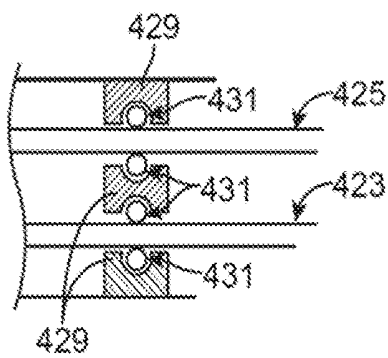

FIG. 58A

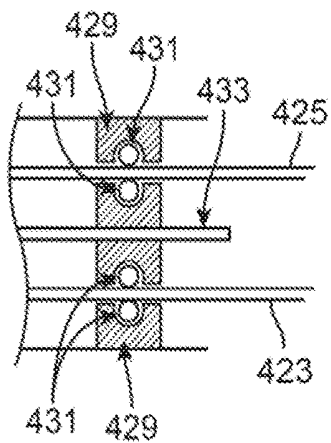
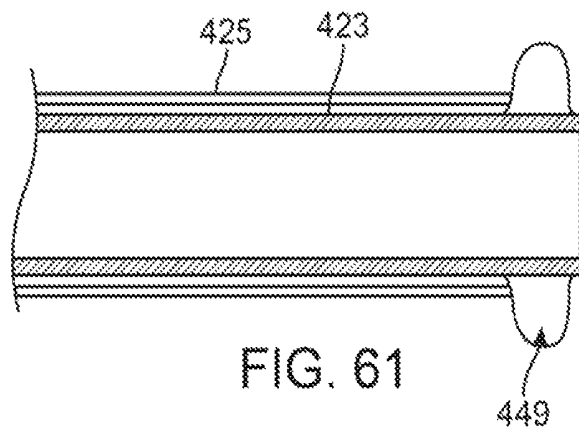
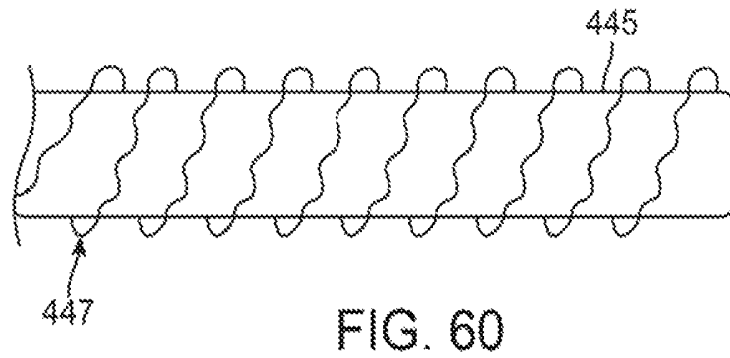
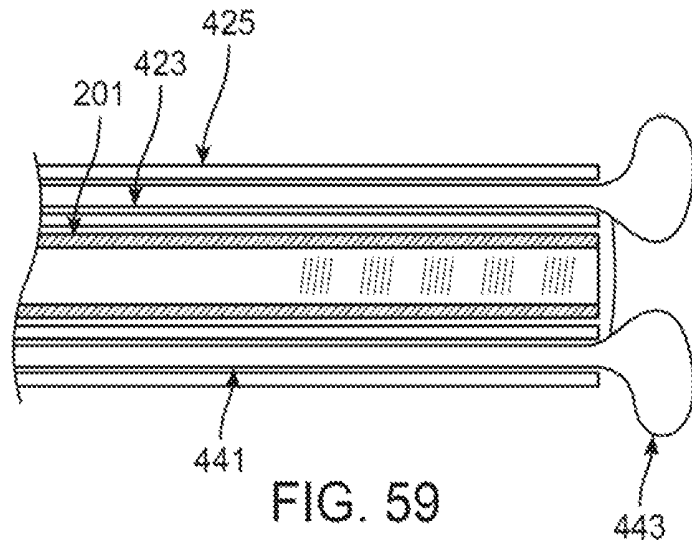

FIG. 58B



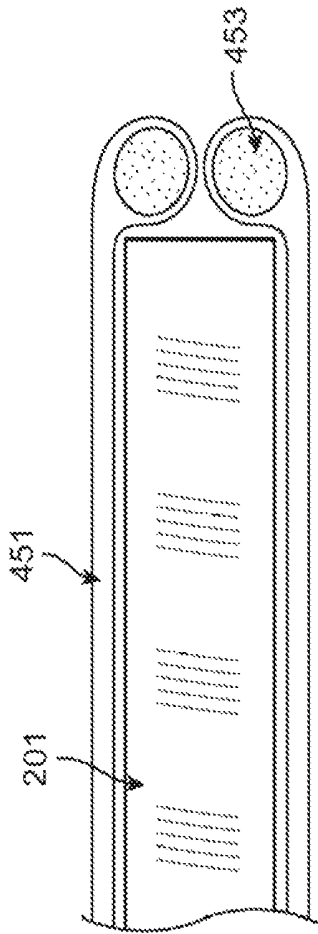

FIG. 62A

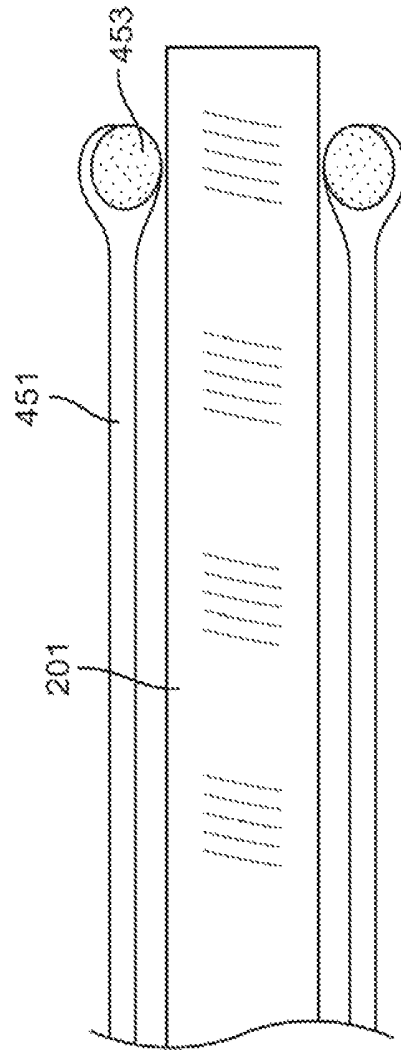

FIG. 62B

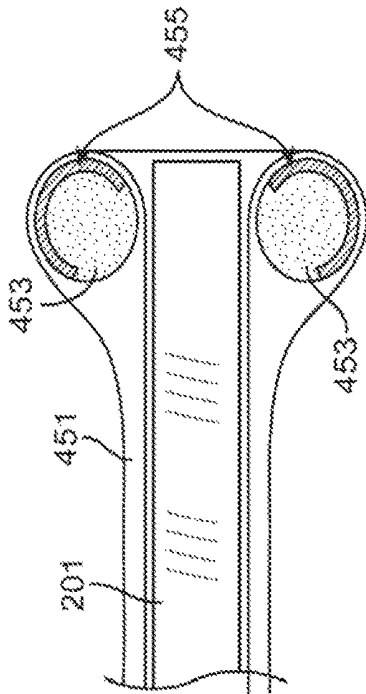

FIG. 63

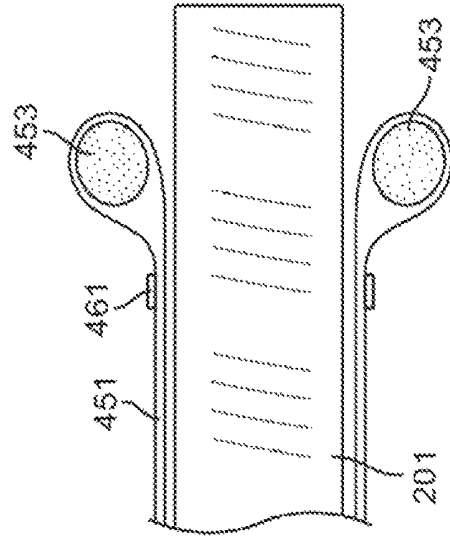

FIG. 64

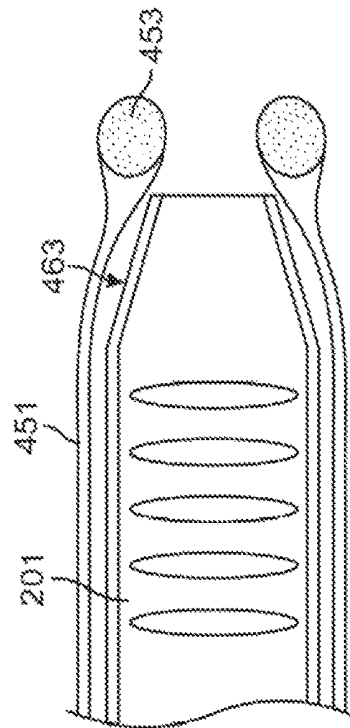

FIG. 65

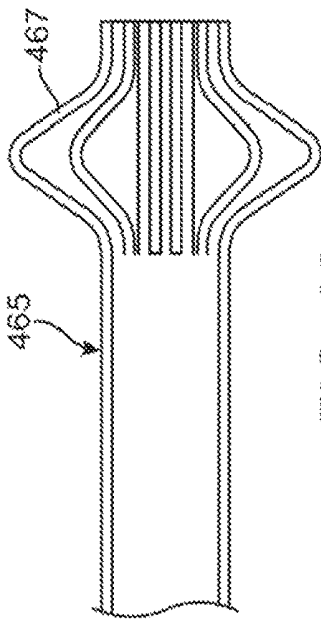

FIG. 66

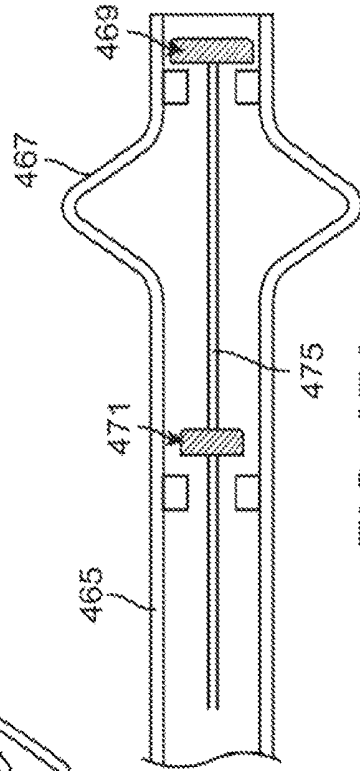

FIG. 67A

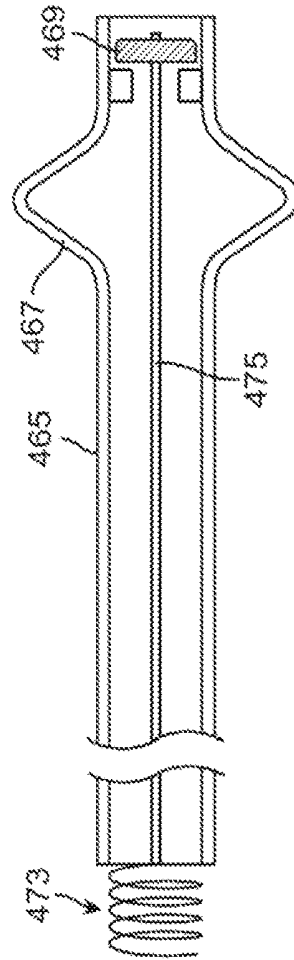

FIG. 67B

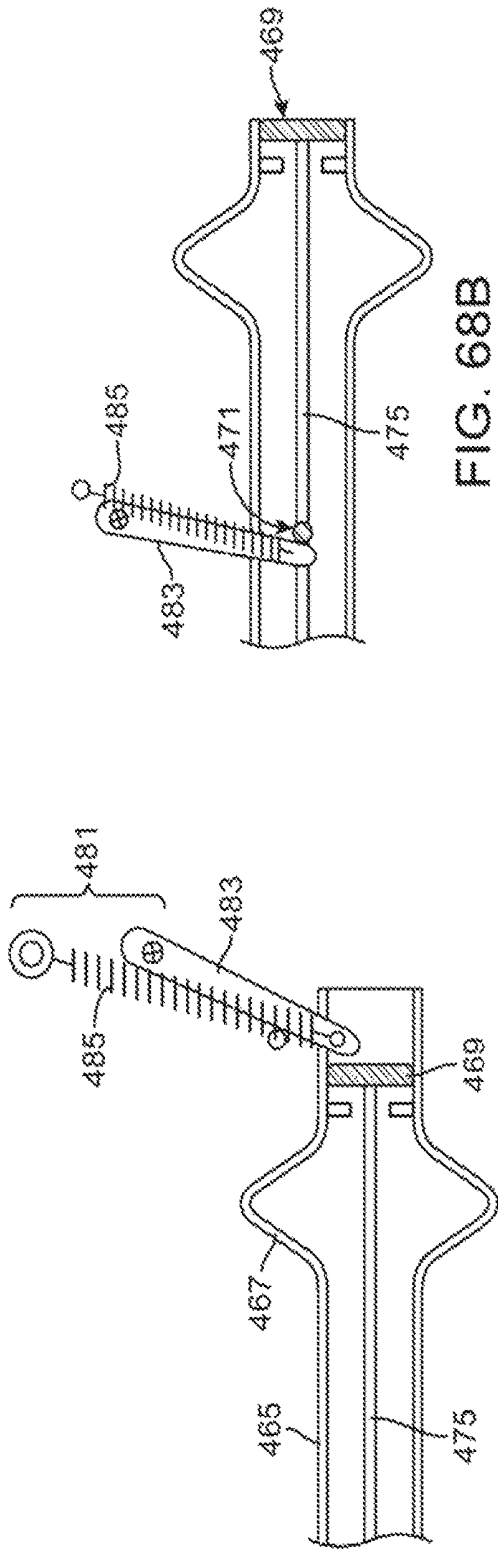

FIG. 68A

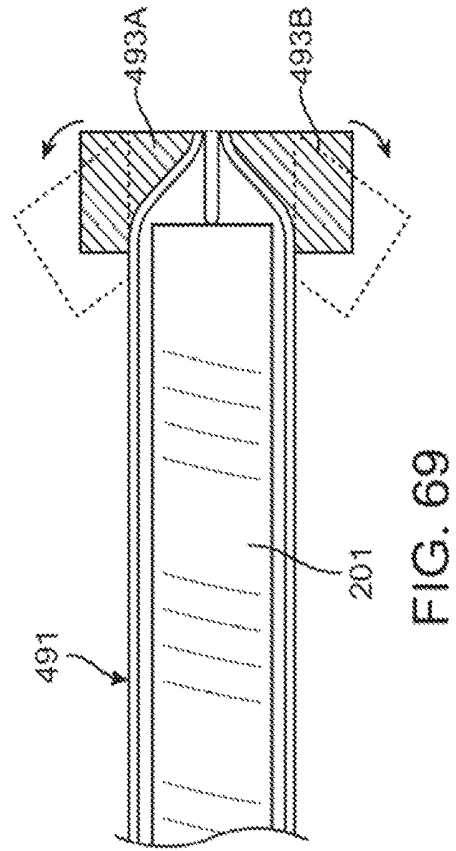

FIG. 69

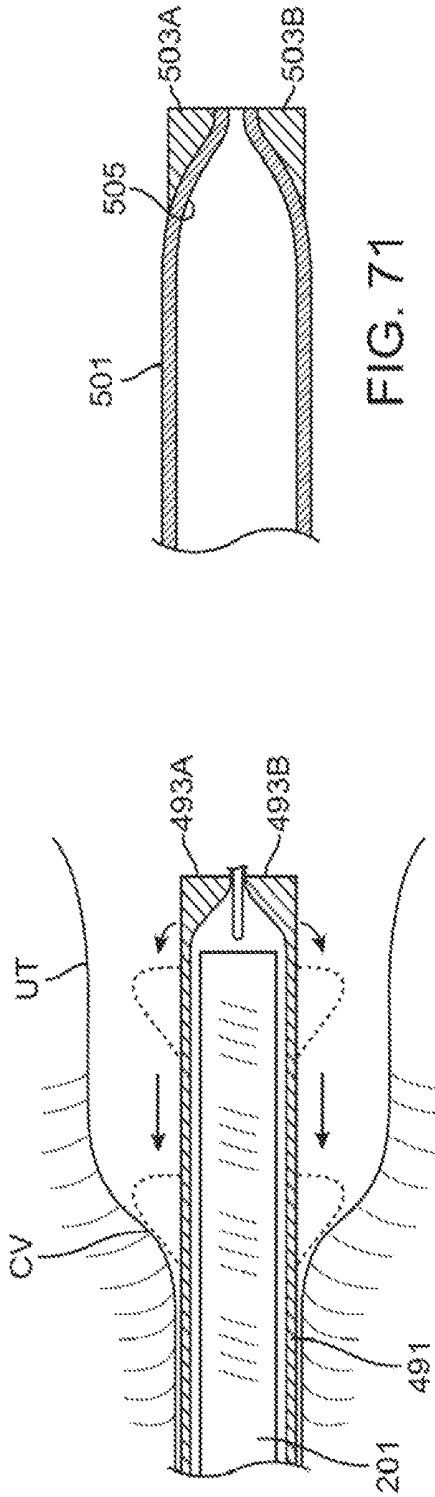

FIG. 71

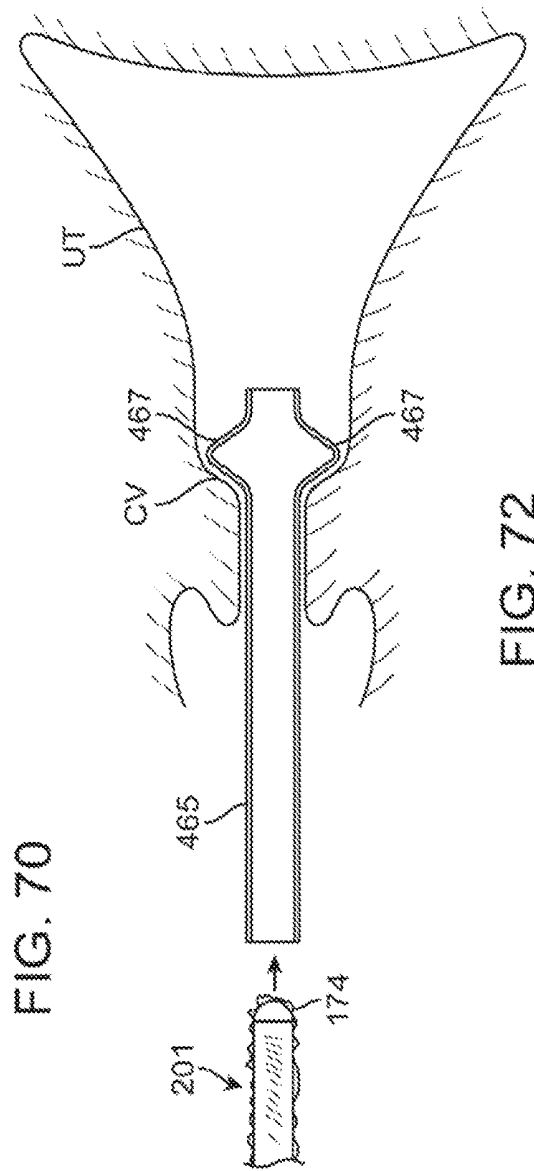

FIG. 72

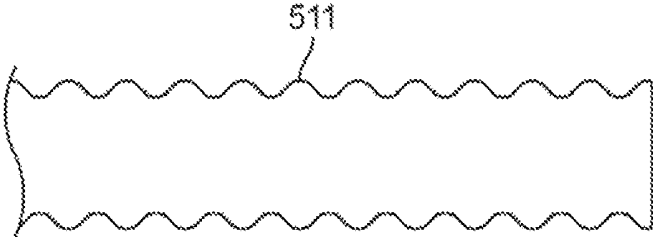

FIG. 73

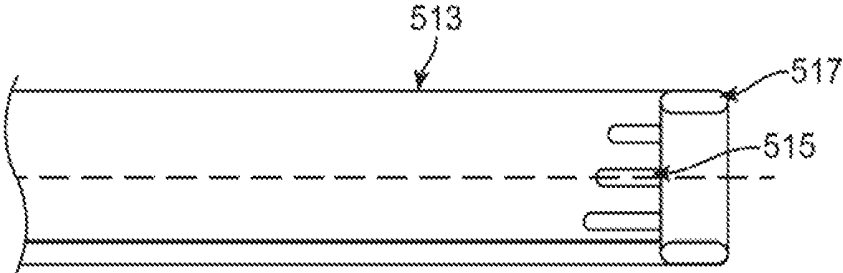

FIG. 74

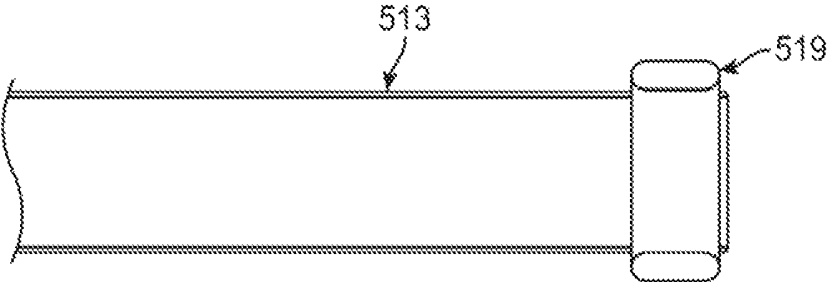

FIG. 75

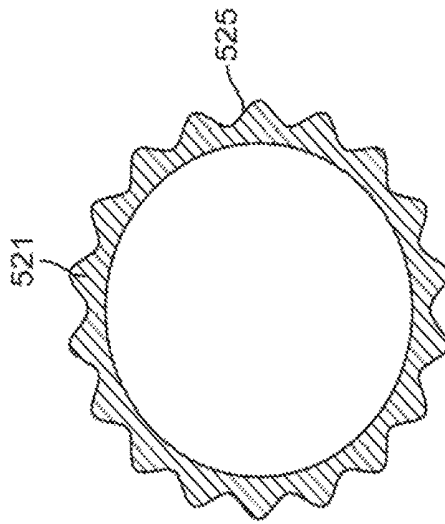

FIG. 76B

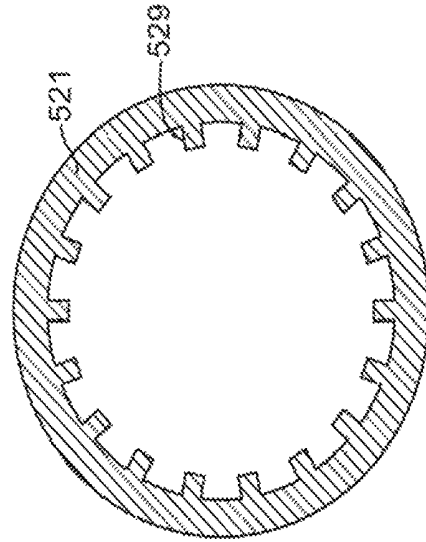

FIG. 76D

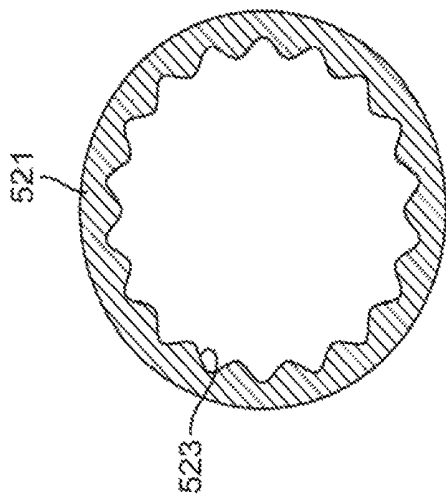

FIG. 76A

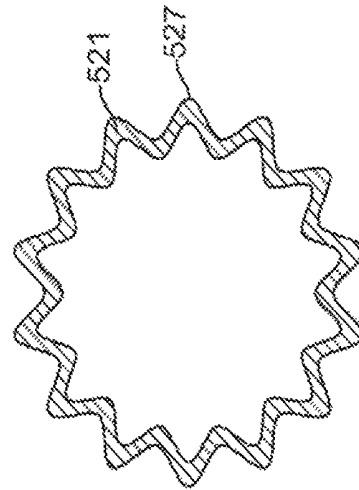

FIG. 76C

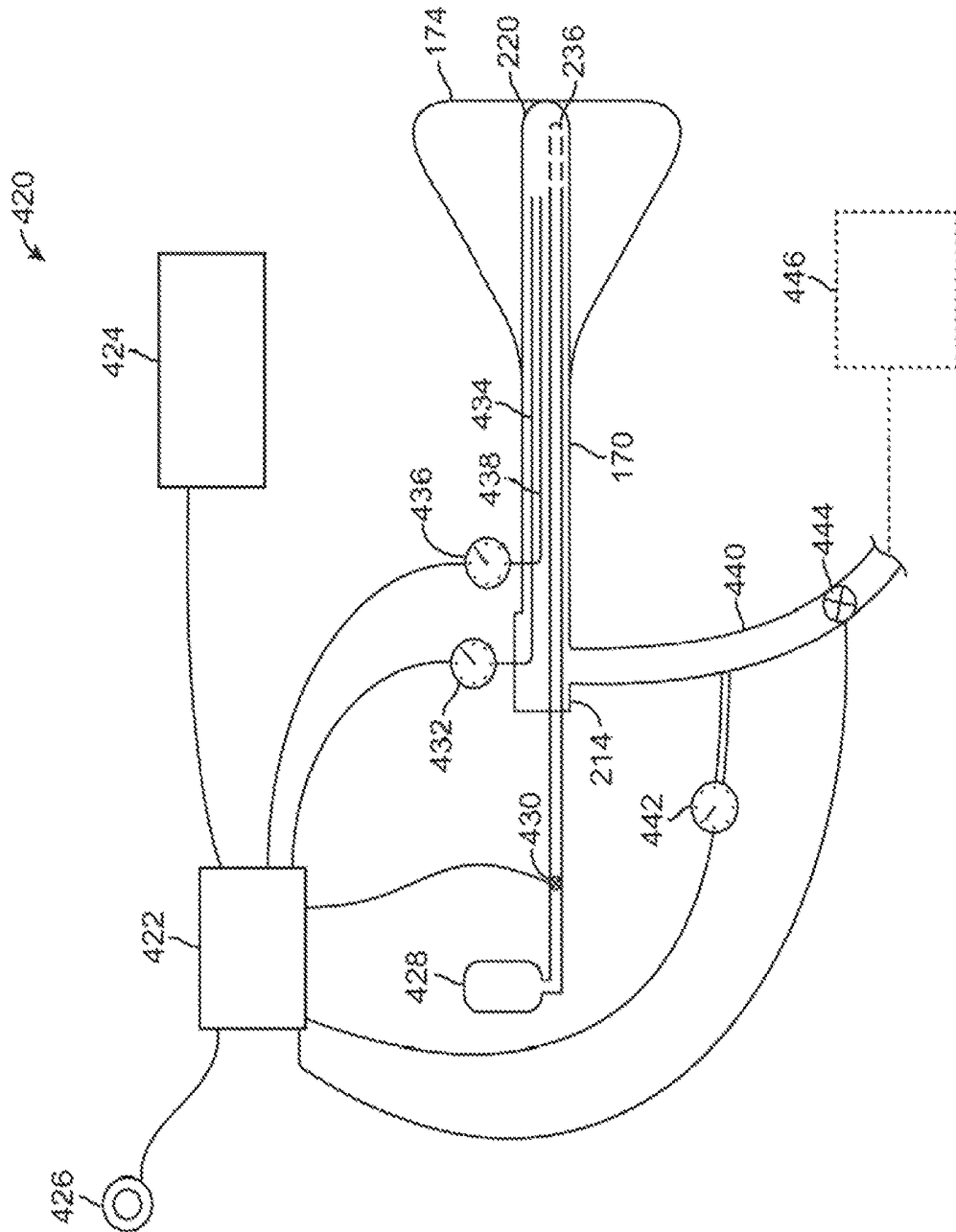

FIG. 77

**METHODS AND APPARATUS FOR
CRYOGENIC TREATMENT OF A BODY
CAVITY OR LUMEN**

CROSS-REFERENCE TO RELATED
APPLICATIONS

This application is a continuation of U.S. patent application Ser. No. 13/361,779 filed Jan. 30, 2012 (now U.S. Pat. No. 9,283,022), which claims the benefit of priority to U.S. Provisional Application No. 61/462,328 filed Feb. 1, 2011 and U.S. Provisional Application No. 61/571,123 filed Jun. 22, 2011, each of which is incorporated herein by reference in its entirety.

FIELD OF THE INVENTION

The present invention relates to medical devices. In particular, the present invention relates to methods and apparatus for therapeutic devices capable of exposing areas of the body to elevated or decreased temperatures, in a highly controlled manner.

BACKGROUND OF THE INVENTION

In the last few decades, therapeutic intervention within a body cavity or lumen has developed rapidly with respect to delivery of energy via radiofrequency ablation. While successful in several arenas, radiofrequency ablation has several major downsides, including incomplete ablation, frequent lack of visualization during catheter insertion, potential for overlap during treatment (with sonic areas receiving twice as much energy as other areas), charring of tissues and requirements for frequent debridement, frequent requirements for additional doses of energy after debridement, and potential perforation of the body cavity or lumen due to the rigidity of the RF electrodes.

The current state of the art would benefit from minimally invasive devices and methods which deliver thermal energy to a desired area or extract energy from a desired area, in a consistent, controlled manner that does not char or inadvertently freeze certain tissues or create excessive risk of unwanted organ or lumen damage.

SUMMARY OF THE INVENTION

When bodily tissues are exposed to even slightly elevated temperatures (e.g., 42 degrees C. or greater), focal damage may occur. If the tissues are exposed to temperatures greater than, e.g., 50 degrees C., for an extended period of time, tissue death will occur. The energy delivered by RF can then be excessive while a more controlled treatment can be achieved with heated fluids and/or vapors.

Generally, devices for delivering controlled treatment may comprise a source for a heated liquid and/or gas, e.g., hot water/steam, one or more pumps to deliver said hot water/steam, a catheter having one or more lumens defined therethrough and also having one or more ports to deliver or circulate the heated liquid and/or gas, e.g., hot water and/or vapor, to a controlled site in a controlled manner. The catheter may also have optional pressure and temperature sensing elements. The optional pressure and temperature sensing elements may allow the operator to monitor and/or control the pressure and temperature within the treatment zone and also prevent the pressure from becoming too high. The treatment site may be delineated by inflatable or expandable members which are pressurized or expanded to

a target pressure to form a seal with the body cavity/lumen. The heated liquid and/or gas may then be delivered to the area contained by the inflatable/expandable members at a pressure that is less than that of the inflatable/expandable members thereby effectively containing the treatment area between these inflatable/expandable members. Optionally, a chilled, room temperature, or warmed fluid such as water may then be used to rapidly terminate the treatment session.

The catheter having the inflatable/expandable members and optional pressure or temperature-sensing elements may be fitted within the lumen of an endoscope or other visualization device allowing the therapy to be delivered under direct visualization. In addition to direct visualization, this advance allows the scope to function as an insulator for the treatment catheter, thereby preventing unwanted exposure of body cavities/lumens to the elevated temperatures found in the heated liquid and/or gas coursing within the treatment catheter.

Generally, the heated liquid and/or gas may be heated to a temperature of between, e.g., 50 and 100 degrees Celsius. Exposure to these less elevated temperatures may allow for more controlled tissue damage and may obviate issues typically associated with the higher energy forms of treatment. It is understood and known in the art that the lower the temperature, the longer the dwell/treatment time needed. One treatment modality may be to deliver the heated liquid and/or gas at a temperature of, e.g., about 70 degrees C. for 5 minutes. Another modality may be to treat the tissue with the heated liquid and/or gas at a temperature of e.g., 90 degree C. for 30 secs.

Among other features, the system may also include 1) the ability to thoroughly treat the treatment area due to the use of confining balloon(s) and/or use of an umbrella-like seal and use of a pressurized heated liquid and/or gas as the energy delivery medium, 2) the ability to treat relatively large areas in a very controlled manner due to the adjustable relationship between the two treatment-area defining inflatable/expandable components (e.g. balloon(s) and/or an umbrella-like seal), 3) the ability to form a liquid and/or gas-tight seal between the balloon(s) (and/or an umbrella-like seal) due to the catheter for the distal balloon traveling within the lumen of the proximal balloon catheter (avoidance of leakage around the catheters that the balloons can seal about), 4) the optional ability to monitor and control the pressure within the treatment area to ensure that the treatment area is not exposed to excessive pressures and that the pressure in the treatment area is prohibited from exceeding a pressure of the treatment area defining balloons, 5) the ability to ablate to a controlled depth in a reliable manner due to the lower energy and longer exposure times which allow the submucosa to cool itself with incoming blood flow, 6) the optional ability to fit within a working channel of an endoscope so that the device need not be inserted in a blind manner, 7) the ability to combine thermal or cooling therapy with delivery of active agents (e.g., anesthetic for pre-treatment of the target area or a chemotherapeutic for the treatment cancer or precancerous lesions, etc.), 8) the ability to fill the treatment defining area with fluid (e.g. cool, warm or room temperature fluid) capable of neutralizing the thermal or cooling energy in the treatment area in order to prevent potential damage caused by balloon rupture or seepage around the balloon and/or expandable member, 9) the ability to pre-chill (or pre-warm) the treatment area so that the submucosal tissues can be protected against the elevated (or cooling) temperature to which the lumen or bodily organ is being exposed, 10) the ability to adjust the treatment temperature time and/or temperature, 11) the

ability to have modular, automated or semi-automated components and controls for handling the cooling, heating, inflations, deflations, infusions and/or extractions, 12) the ability to treat through the working channel of an endoscope or alongside an endoscope, 13) the ability to treat through a variety of endoscopes, e.g. nasal, gastrointestinal, esophageal, etc., 14) the ability to use off-the-shelf and/or disposable components to handle the fluid and pressure controls, or to use an automated or semi-automated system.

Additionally, the system may also incorporate features that may allow for efficacious therapy. For example, the system may utilize a sub-zero degrees Celsius temperature fluid lavage. This cold lavage may allow for much better control than charring and heating of the tissue and instead may provide a consistent depth of ablation in a manner that allows for rapid recovery and minimal post-operative pain (as opposed to heating methods). In addition, by using lavage of a liquid rather than cryogenic sprays (e.g., sprays which rely on the judgment of the user for determining time of spray application or spray location, etc.), the potential for over-ablation may be avoided. Also, the relatively colder cryogenic sprays have been found, in many cases, to result in damage to the endoscope while the higher temperatures possible with the system described herein (e.g., anywhere from -5 degrees Celsius to -90 degrees Celsius) is much less likely to damage the delivery equipment.

Secondly, the apparatus may utilize an umbrella-like element in the gastric space to allow for ablation of tissue regions, such as the lower esophageal sphincter at the gastroesophageal junction. This ablation is generally difficult to perform using balloon-based ablation technologies due to the expansion of the sphincter into the stomach. By utilizing an expandable, umbrella-like structure to form a firm seal at this site while allowing the ablation liquid and for gas (heated or chilled) to contact the entire gastroesophageal junction. In addition, a spring-loaded element or other external force mechanism may be incorporated to provide for steady pressure and a firm seal against, the stomach lining.

The apparatus may also be utilized with or without a balloon in body lumens or cavities that can be otherwise sealed. For example, a hypothermic fluid lavage of the uterus may be accomplished by introducing a subzero (Celsius) fluid into the uterus via cannulation of the uterus with a tube or cannula. If the tube is of sufficient diameter, backflow of the hypothermic lavage into the cervix and vagina may be prevented without the need for a balloon to contain the fluid. Use of balloons may be avoided for this particular type of application. In utilizing a hypothermic lavage, a fluid may be used that remains fluid even at subzero temperatures. This fluid may then circulate in the lumen (with or without a balloon) in order to achieve ablation.

In using a hypothermic liquid rather than a gas, a greater thermal load can be repeatedly extracted from the tissue under controlled physiologic conditions using, a liquid beyond the thermal load which may be extracted using a compressed gas. A liquid lavage, on the other hand, may be controlled based on temperature and pressure to provide a repeatable effect on the target organ. Compressed gas or other rapid cooling mechanisms, though, may be utilized in combination with this therapy in order to chill a solution to subzero temperatures after introduction into the body. In this variation, the biocompatible liquid capable of retaining liquid characteristics in a subzero state, or "anti-freeze solution", may be infused into the lumen or cavity after which the cooling probe may be introduced. Heat may be drawn from the anti-freeze solution until the desired hypo-

thermic ablation temperature has been achieved for the desired duration of time. Fluid may or may not be circulated during, this process via a pump or agitating element within the catheter in order to improve distribution of the ablative fluid.

In yet another variation, the treatment fluid may function to expand the uterus for consistent ablation, function to distribute the cryoablative freezing more evenly throughout the uterus, and potentially function to slow or prevent ice formation at the surface of the lumen or body cavity. The apparatus may be used with, for example, lipophilic, hydrophilic or amphipathic solutions with the latter two being having the ability to remove any aqueous fluid from the surface of the target cavity or lumen which may interfere with conduction of the heat from the target tissues into the cryoablative fluid.

Additionally and/or alternatively, the apparatus and methods described herein may be used as an adjunct to other treatments, such as the Her Option® therapy (American Medical Systems, Minnetonka, Minn.), by utilizing a lavage of the target cavity or lumen such as the uterus with the aqueous anti-freeze solution either prior to or during treatment in order to provide superior transmission of cryoablation with other existing, cryoprobes without creation of the insulating ice layer at the surface. Moreover, lavage of the target lumen or cavity with a biocompatible antifreeze solution may be performed to improve transmission of the cryoablative effect as an adjunct to any cryotherapy treatment anywhere in the body where applicable. As described herein: the cryoablative fluid may also be introduced and/or lavaged within the target lumen or body cavity within a balloon which may be expanded to contact the walls of the lumen or body cavity. The cryoablative treatment fluid may be actively lavaged in and out of the balloon and/or deeply chilled by a cryoprobe within the balloon after introduction into the body cavity or lumen. Moreover, the anti-freeze solution may also comprise various salts and/or other biocompatible molecules capable of driving the freezing temperature of the solution below, e.g., -10 degrees Celsius. Additionally, the fluid may be capable of resisting, freezing even at a temperature of, e.g., -90 degrees Celsius. A combination of salts, alcohols, glycols and/or other molecules may be used to provide this resistance to freezing in an aqueous solution.

In yet another variation, a cryoprobe with, e.g., a protective cage and/or a recirculator/fluid agitator, may be utilized to ensure that the hypothermic fluid is evenly distributed. The cage may be configured into various forms so long as it exposes the fluid to the surface of the cryoprobe while preventing direct contact of the cryoprobe with the wall of the lumen or cavity to be ablated (such as a uterus). A recirculator may comprise, e.g., a stirring element at the tip of the cryoprobe, an intermittent or continuous flow system or other fluid movement mechanism.

In another variation, to facilitate the balloon expanding and conforming readily against the tissue walls of the uterus, the balloon may be inflated with a gas or liquid. Alternatively, the balloon may be filled partially or completely with a conductive material. Once the elongate shaft has been introduced through the cervix, and into the uterus, the distal opening of the shaft may be positioned distal to the internal os and balloon may be deployed either from within the shaft or from an external sheath. The balloon may be deployed and allowed to unfurl or unwrap within the uterus. The cooling probe may be introduced through the shaft and into the balloon interior (or introduced after insertion of the conductive elements).

The conductive elements may be introduced into the balloon interior through an annular opening within the distal end of the shaft until the balloon is at least partially or completely filled with the elements. The conductive elements may generally comprise any number of thermally conductive elements such as copper spheres or some other inert metal such as gold. These conductive elements may be a traumatic in shape and are small enough to fill the balloon interior and conform the balloon walls against the uterine walls to ensure consistent contact with the tissue, e.g., about 20 ml in volume of the elements. The conductive elements may also help to fill any air pockets which may form particularly near the tapered portions of the balloon and insulate the tissue from the ablative effects of the cryoablative fluid. For instance, the conductive elements may be formed into spheres having a diameter of, e.g., 0.8 mm to 4 mm or larger. To ensure that that conductive elements are fully and evenly dispersed throughout the balloon interior, the elements may be introduced through the shaft via an ejector or push rod, auger, compressed air, etc. In particular, the conductive elements may fill the tapered portions of the balloon to ensure that the balloon is positioned proximate to and in contact with the uterine cornu to fully treat the interior of the uterus.

With the conductive elements placed within the balloon, the cryoablative fluid may be introduced within and through the balloon such that the conductive elements facilitate the thermal transfer from the contacted uterine walls. Once the cryoablative treatment has been completed, the conductive elements may be removed through the shaft via a vacuum force or other mechanical or electromechanical mechanisms and the balloon, once emptied, may also be withdrawn from the uterus.

The cooling probe introduced into the interior of the balloon may comprise a number of different configurations which facilitate the introduction of the cryoablative fluid into the balloon. One such variation, the shaft may have one or more cooling, members which project from the distal end of the shaft at various angles. Another variation of the cooling probe may have a rotating base and spray member positioned upon the shaft. The spray member may have a surface which is meshed, latticed, perforated, etc. such that the cryoablative fluid introduced through the shaft may enter the rotating base and spray member where it may be evenly dispersed through the spray member and into the interior of the balloon for treatment.

The cooling probe positioned within the balloon may be variously configured and may include further variations. The cooling probe assembly may comprise an exhaust catheter having, an atraumatic tip and an imaging instrument such as a hysteroscope positioned within. One or more supporting members or inserts may be positioned throughout the length of the lumen to provide structural support to the catheter and to prevent its collapse and a probe support (e.g., flat wire, ribbon, etc.) may extend through the catheter interior.

The probe support may be supported within the lumen via the inserts such that the probe support separates the lumen into a first channel and a second channel where the cooling lumens may be positioned along the probe support within the second channel while the first channel may remain clear for the optional insertion of a hysteroscope. Because of the thickness of the probe support relative to its width, the probe support may be flexed or curved in a single plane while remaining relatively stiff in the plane transverse to the plane.

The probe may further include one or more cooling lumens which are positioned along the probe support within the second channel. Because the cooling lumens are located,

along, the second channel, as separated by the probe support, one or more windows or openings may be defined along the length of the probe support to allow for the passage of any cryoablative fluid to proliferate through the entire lumen defined by the catheter. The number of cooling lumens may also be varied to number more than three lumens terminating at different positions along the active portion.

As the cryoablative fluid is introduced into and distributed throughout the catheter lumen, the exhaust catheter may also define one or more openings to allow for the cryoablative fluid to vent or exhaust from the catheter interior and into the interior of the balloon.

One example for a treatment cycle using a two cycle process may include the introduction of the cryoablative fluid for a treatment time of two minutes where the surrounding tissue is frozen. The fluid may be withdrawn from the balloon and the tissue may be allowed to thaw over a period of five minutes. The cryoablative fluid may be then reintroduced and the tissue frozen again for a period of two minutes and the fluid may then be withdrawn again to allow the tissue to thaw for a period of five minutes. The tissue may be visually inspected, e.g., via the hysteroscope, to check for ablation coverage. If the tissue has been sufficiently ablated, the assembly may be removed from the uterus, otherwise, the treatment cycle may be repeated as needed. In other alternatives, a single cycle may be utilized or more than two cycles may be utilized, as needed, to treat the tissue sufficiently. Furthermore, during the treatment cycle, a minimum pressure of, e.g., 40 to 80 mm Hg, may be optionally maintained by the cryogenic liquid or by a gas (e.g., air, carbon dioxide, etc.) to keep the balloon and uterus open.

The balloon may be expanded within the uterus and particularly into the uterine cornu by an initial burst of gas or liquid. Other mechanisms may also be used to facilitate the balloon expansion. One variation may utilize one or more supporting arms extending from a support which may be deployed within the balloon. The supporting arms may be variously configured although they are shown in this example in a Y-configuration. Yet another variation may include the supporting arms incorporated into elongate channels or pockets defined along the balloon itself.

Aside from the balloon itself and the use of balloons for obstructing the os, internal os, and/or external os, balloons or inflatable liners may also be used to insulate the cryogenic fluid during delivery into the balloon to protect the surrounding tissue structures which are not to be ablated, such as the cervix.

In controlling the ablative treatments described above, the treatment assembly may be integrated into a single cooling system contained entirely within the handle assembly or it may be separated into components, as needed or desired. In either case, the cooling system may generally comprise a microcontroller for monitoring and/or controlling parameters such as cavity temperature, cavity pressure, exhaust pressure, etc.

A coolant reservoir, e.g., nitrous oxide canister, may be fluidly coupled to the handle and/or elongate shaft via a coolant valve which may be optionally controlled by the microcontroller. The coolant reservoir may be in fluid communication with the cooling probe assembly and with the interior of the balloon. Additionally, an exhaust lumen in communication with the elongate probe and having a back pressure valve may also include a pressure sensor where one

or both of the back pressure sensor and/or valve may also be in communication with the microcontroller.

BRIEF DESCRIPTION OF THE DRAWINGS

For the purposes of the drawings and preferred embodiments, applications to the esophagus and uterus will be shown. However, the apparatus and methods may be applied to any body cavity/lumen which may be visualized with an endoscope or other visualization mechanism.

FIG. 1 shows an example of a device advanced through an endoscope, e.g., a nasally or orally inserted scope.

FIG. 2 shows an example of a device advanced through the working channel of nasal endoscope.

FIG. 3 shows an example of a device attached to a logic controller.

FIG. 4 shows an example of a device placed through working channel of nasal endoscope and deployed within an esophagus for treatment.

FIG. 5 shows an example of a device advanced alongside an endoscope.

FIGS. 6A to 6C show a device being introduced through an endoscope and deployed for treatment within the esophagus.

FIGS. 7A to 7C show examples of a device introduced through an endoscope for insertion within a bladder.

FIGS. 8A to 8C show examples of a device preparing the treatment area with a pre-treatment lavage prior to treatment.

FIG. 9 shows an example of a distal occlude having an umbrella-like shape deployed in proximity to a gastroesophageal junction for treatment.

FIG. 10 shows another example of an endoscopic balloon sheath having a distal occluder expanded distal to gastroesophageal junction for treatment

FIG. 11 shows another example where the treatment fluid is introduced between the deployed balloons for treatment.

FIG. 12 shows another example of an adjustable size balloon device for treatment of the esophagus.

FIGS. 13A and 13B show another example of a single balloon device for ablation treatment within the uterus and/or endometrial lining.

FIGS. 14A and 14B show yet another example of conductive lattice/cage deployed for cryoablative treatment.

FIG. 15 shows another example of an external cervical as occluding device.

FIG. 16 shows another example of an internal, cervical as occluding device.

FIGS. 17A and 17B show another example of a device having a deployable low-pressure conforming balloon used for cryogenic treatment of the uterus.

FIGS. 18A to 18D show another example of a conforming balloon which may also be filled partially or completely with a conductive material for cryoablative treatment

FIG. 19 shows another example of a cooling probe having one or more cooling members projecting from the distal end of a shaft.

FIG. 20 shows another example of a cooling probe having a rotatable base and spray member.

FIG. 21A shows a side view of an integrated treatment assembly.

FIG. 21B shows an example of the assembly advanced through the cervix and into the uterus where the sheath may be retracted via the handle assembly to deploy the balloon.

FIG. 22A shows a side view of a system which allows for adjustably setting a length of the balloon along the shaft.

FIG. 22B shows a side view of the balloon everted within the shaft lumen for delivery.

FIGS. 23A and 23B show perspective and side views, respectively, of another example of a cooling probe assembly having a flat wire integrated through the probe.

FIG. 24 shows a perspective view of the cooling probe assembly with one or more openings defined along the probe assembly.

FIGS. 25A and 25B show end views of a cross-section of the cooling probe and the distal end of the probe.

FIGS. 26A to 26L show perspective views of various tubular members which may be used for the cooling probe assembly.

FIGS. 27A and 27B show perspective views of a cooling probe assembly utilizing one or more discrete ring members linearly coupled to one another.

FIGS. 28A and 28B show cross-sectional end views of another variation of a cooling probe assembly coupled via a covering and/or insert members.

FIG. 29 shows a perspective view of another variation of a cooling probe assembly having one or more insert members coupled along a wound spring body.

FIGS. 30A and 30B show cross-sectional side views of another variation of insert members supported along a spring body.

FIG. 31 shows a detail side view of one variation of a pivotable cooling lumen body.

FIG. 32 shows a side view of another variation of one or more insert members having an integrated covering.

FIG. 33 shows a side view of yet another variation of one or more insert members having a slidable joint attached.

FIG. 34 shows a side view of another variation of a spring body having one or more cooling lumens attached directly to the spring.

FIG. 35 shows a side view of another variation of a spring body having the one or more insert members.

FIG. 36 shows a side view of another variation of a spring body having the one or more cooling lumens and a secondary lumen.

FIG. 37 show cross-sectional end views of variations of the secondary lumen.

FIGS. 38A and 38B show perspective views of another variation of the cooling probe utilizing a main delivery line and at least two side delivery lines.

FIG. 38C shows a detail view of the side delivery line having an adjustable mandrel slidably positioned within.

FIG. 39 shows a cross-sectional side view of another variation of the cooling probe assembly where the main delivery line and side delivery lines are in fluid communication through a common chamber.

FIG. 40A and 40B show cross-sectional end views of variations of the exhaust lumen and the respective cooling lumens.

FIG. 41 shows a cross-sectional side view of another variation of a cooling probe assembly having a single introduction line and a single delivery line.

FIG. 42 shows a cross-sectional side view of a cooling probe assembly inserted within a balloon within the uterus.

FIGS. 43A and 43B show side views of various examples of side delivery lines having the openings aligned in different directions.

FIG. 44 shows a side view of a cooling probe variation having a skived window for facilitating visualization.

FIG. 45 shows a side view of an example of a balloon having one or more supporting arms extendable within the balloon.

FIG. 46 shows a side view of another example of a balloon having one or more supporting arms attached to the cooling probe assembly.

FIG. 47 shows a side view of another example of a balloon having one or more supporting arms also defining one or more openings for delivering the cryoablative fluid.

FIG. 48 shows a side view of yet another example of a balloon having the one or more supporting arms positioned within elongate channels along the interior of the balloon.

FIG. 49 shows a side view of an example of an inflatable liner or balloon located along the outside distal surface of the sheath.

FIG. 50 shows a side view of another example of an inflatable liner or balloon located along the inside distal surface of sheath.

FIG. 51 shows a side view of another example where expandable foam may be deployed via the outer sheath.

FIG. 52 shows a side view of another example where a heating element may be located along the inner or outer surface of the elongate shaft.

FIG. 53 shows a side view of another example where a ring balloon may be inflated along either the sheath or shaft to either insulate the surrounding cervical tissue or to ensure secure placement of the shaft and/or balloon during treatment.

FIG. 54 shows a cross-sectional side view of another variation where the outer sheath may be formed as an inflatable structure.

FIGS. 55A and 55B show side views of variations of an outer sheath having a reconfigurable distal end.

FIG. 56 shows a side view of another variation of a balloon positioned along an outer surface of the outer sheath.

FIG. 57 shows a cross-sectional side view of one variation of a dual-sheath design.

FIG. 58A and 58B show cross-sectional detail views of the sealing between the inner and outer sheaths.

FIG. 59 shows a partial cross-sectional side view of another dual-sheath variation having an expandable balloon contained between the sheaths.

FIG. 60 shows a side view of another variation of a sheath having a reinforced structure.

FIG. 61 shows a cross-sectional side view of another variation of an outer sheath having, an adjustable balloon member.

FIGS. 62A and 62B show cross-sectional side views of another variation of an outer sheath having, a reconfigurable distal end.

FIG. 63 shows a cross-sectional side view of the reconfigurable distal end having one or more lubricious surfaces.

FIG. 64 shows a partial cross-sectional side view of another variation where the reconfigurable distal end may be attached as a separate component.

FIG. 65 shows a cross-sectional side view of another variation where a distal end of the cooling probe has a tapered distal end.

FIG. 66 shows a side view of another variation of an outer sheath having a radially expandable portion.

FIGS. 67A and 67B show cross-sectional side views of variations of the locking mechanism for the expandable portion.

FIGS. 68A and 68B show cross-sectional side views of an illustrative example of an overcenter linkage mechanism.

FIG. 69 shows a cross-sectional side view of another variation of an outer sheath having one or more distal cam members.

FIG. 70 shows a cross-sectional side view of the one or more cam members deployed in their expanded configuration and secured against the cervical tissue.

FIG. 71 shows a cross-sectional side view of another variation where the cammed distal end positioned on a tapered outer sheath.

FIG. 72 shows a side view of an example of how the outer sheath may be initially deployed and secured and the cooling probe assembly advanced separately.

FIG. 73 shows a side view of another variation where the outer sheath is configured as a corrugated structure.

FIG. 74 shows a partial cross-sectional side view of another variation of the outer sheath having an inflatable balloon along an inner surface.

FIG. 75 shows a partial cross-sectional side view of another variation of the outer sheath having an inflatable balloon along an outer surface.

FIGS. 76A to 76D show cross-sectional end view of variations of the outer sheath having an integrated feature to provide further insulation to the surrounding tissue.

FIG. 77 shows an exemplary schematic illustration of the treatment assembly integrated into a single cooling system.

DETAILED DESCRIPTION OF THE INVENTION

FIG. 1 shows a perspective view of one example of the treatment assembly 10 positioned within a working channel 14 of an endoscope 12 (e.g., orally or nasally insertable scope). In this example, the treatment device 16 itself may utilize a first catheter 18 having an inflatable or expandable balloon member 22 and a second catheter 20 that may slide freely with respect to the first catheter 18 and also having an inflatable balloon member 24 at its distal end. The first catheter 18 as well as second catheter 20 may have a liquid and/or gas tight seal 30 formed at the proximal end of the catheters. The inflatable and/or expandable members 22, 24 (shown in this example as inflated balloons) may be pressurized to effectively and safely occlude the lumen. The balloons may be filled with chilled or room temperature fluid to prevent possible damage caused by balloon rupture or seepage around the balloon. Pressure within the inflatable or expandable balloon members may also be monitored to ensure that a tight seal has been formed within the lumen or body cavity.

Additionally, the liquid may be introduced into the treatment area through a liquid and/or gas port 28 and into the lumen of the catheter which terminates with the proximal balloon 22 and leaves the catheter through perforations or holes 32 within the second catheter 20 which terminates in the distal balloon 24, although this flow path may easily be reversed if necessary. Alternatively, one or more ports can be designed into the lumen between the distal 24 and proximal 22 balloons, such that the heated or cooling fluid exits one or more ports 32 in the lumens near the distal balloon 24, and is then evacuated in a port or ports designed within the lumen of the first catheter 18 nearest the proximal balloon 22. In this variation, the endoscope 12 may insulate the catheters allowing the catheters to be much smaller than would be otherwise possible and allowing it to fit within the working channel 14 of a standard endoscope 12. One or more pressure sensors may be used to detect both inflation pressures of the balloons and/or the pressure seen by the body cavity/lumen that is exposed to the treatment liquid/vapor. In the manner, liquid/vapor flow may be controlled by the pressure sensing elements within the body cavity/lumen to ensure that safe pressures are never exceeded. Manual controls may be used for creation and/or maintenance of these pressures (e.g. syringes with stopcocks) or automated and/or semi-automated systems can be used as well (e.g.

pumps with PID loops and pressure sensing interconnectivity. Although the liquid and/or gas for tissue treatment may be heated or chilled prior to introduction into the treatment area in contact with the tissue, the liquid and/or gas may alternatively be heated or chilled after introduction into the treatment area and already in contact with the tissue.

FIG. 2 shows an example where the second catheter 20 and distal balloon member 24 is slidable relative to the proximal balloon 22. This examples illustrates the endoscope inserted through the nasal cavity and advanced through the esophagus ES where the catheters 18, 20 may comprise single or multi-lumen catheters having inflation lumens for the distal 24 and proximal 22 inflatable/expandable elements, infusion port and extraction port. At least one of the catheters may be fitted with either a pressure transducer 42 or a lumen to carry the pressure signal from the treatment area back to the controller or dial gauge. Pressure sensing may be accomplished through a small, air capsule proximal to the distal balloon 24, but within the treatment area. Both of the balloons 22, 24 may be inflated along the esophagus ES in the proximity to the gastroesophageal junction GJ proximal to the stomach ST to create a treatment space 40 which encompasses the tissue region to be treated.

In an alternative embodiment, an extraction lumen may be omitted as a preset dose of heated liquid and/or gas may be delivered, allowed to dwell and then either extracted through the same lumen or rendered harmless with the infusion of cold fluid. This treatment algorithm would provide an even simpler therapy and would rely on the exclusion of a certain area and exposure of that area to a liquid or vapor with the desired energy. Infusion of the liquid or vapor may be controlled to ensure that the treatment area is not exposed to excessive temperatures.

FIG. 3 shows another example where the treatment assembly 10 may be in communication with a controller 50, such as a logic controller. Controller 50 may control certain parameters such as infusion pressure 54 of the fluid as well as fluid temperature 56 and it may be coupled to the assembly by one or more cables 52. The pressure in the treatment area, the elapsed time, the temperature of the fluid, and the extraction rate may also be monitored and controlled.

FIG. 4 shows a detail view of the treatment area 40 defined, in this case, by two balloons 22, 24. The first catheter 18 may open into the lumen just after the proximal balloon 22 and this catheter 18 may be inserted along with or prior to insertion of the second catheter 20. The first catheter 18 internal diameter is greater than the outer diameter of the second catheter allowing for liquid (and/or vapor) to be infused or extracted around the outer diameter of the second catheter 20. The second catheter 20 a first lumen for balloon inflation and a second lumen for evacuating the treatment region 40. With the balloons inflated into contact against the esophagus ES, the treatment area 40 may encompass the tissue region to be treated, e.g., a lesion 60 such as Barrett's esophagus or esophageal cancer lesion and the distal end of the endoscope 12 may be positioned into close proximity to proximal balloon 22 and the treating liquid and/or gas 66 may be infused through the annular lumen 70 defined through first catheter 18 and between second catheter 20 such that the fluid 66 may enter through opening 62 into the treatment region 40 while contained by the balloons. Once treatment has been completed, the fluid may be evacuated 68 through one or more openings 64 located along the second catheter 20 proximal to distal balloon 24 and proximally through the second catheter 20 through the evacuation lumen 72. As previously mentioned, a pressure

sensor 42 (e.g., pressure measuring air capsule) may be positioned along either the first 18 and/or second 20 catheter for sensing the various parameters. Additionally, the treatment liquid and/or gas may include any number of liquids, vapors, or other chemically active (e.g., chemotherapeutic) or inactive compounds for additional treatments to the tissue.

In the event that the treatment is provided by a simple timed dwell, the extraction 72 and infusion 70 lumens may not both be utilized. The pressure sensing element 42 (solid-state, piezoelectric, or other method) may be located on either the first or second catheters and the second catheter and may comprise to simple slidable balloon. A pressure sensor for the treatment may omitted so long as the pressure can be controlled by other mechanisms, e.g., a check valve or a simple gravity fluid column. An active pressure measurement, though, may ensure that safe pressures are not being exceeded.

The second catheter 20 may fit easily within the first catheter 18 and may be slid inside the first catheter 18 until its distal balloon 24 is distal to the first balloon 22. The distal balloon 24 may then be inflated just beyond the distal portion of the treatment area 40 and the endoscope 12 may be pulled back. The most proximal extent of the lesion 60 may then be identified and the proximal balloon 22 may be inflated proximal to this area. Once the treatment area 40 has been enclosed (which may be verified by infusing liquid 66 and/or vapor under visualization and observing, the seal around the balloon, balloons and/or expandable member) the lumen or body cavity may then be filled with the treatment liquid and/or vapor to a safe pressure. The liquid and/or vapor may also contain active agents (e.g. chemotherapeutic and/or anesthetic agents) and comprise more than simply an inactive liquid and/or vapor. Options would be for the active agents to be delivered prior to, during and/or post treatment of the heating (or cooling) liquid and/or vapor.

As the treatment assembly 16 does not contain the treatment liquid or vapor within a balloon(s) or expandable member and allows it to freely flow over the treatment area, the therapy may be applied consistently leaving no areas left untreated (as is frequently seen with balloon infusion-based or RF therapies). Additionally, treatment may be accomplished with a heated liquid (rather than a high energy electrode or excessively hot vapor) or a more controlled treatment can be achieved through the use of a relatively cooler liquid with a longer treatment time. In addition, the esophagus ES is a fluid transport type organ (lumen) and may be more compatible to fluid based therapies than with RF-based therapies. It is also believed that the safety margin of such treatments may be better than with an RF-based therapy.

FIG. 5 shows an alternative embodiment of the device in which the first catheter 18 and second catheter 20 of the treatment assembly 16 may be inserted alongside an endoscope 12 which may be used to provide for visualization. Due to the small size of the catheters, this embodiment is feasible.

FIGS. 6A to 6C illustrate an example for a placement procedure for the assembly for the treatment of a body lumen such as the esophagus ES. The catheters may be inserted simultaneously or separately through the working channel of the endoscope 12. In one example, the larger first catheter 18 may be inserted first followed by insertion of the second catheter 20 within the lumen of the first catheter 18. Once both single or multi-lumen balloon catheters have been inserted and after the endoscope 12 has been advanced through the esophagus ES and into proximity to the tissue

treatment region, the distal balloon **24** may be advanced to define the distal end of the treatment area and inflated (e.g., with chilled, room or body temperature fluid) while under visualization through the endoscope **12**, as shown in FIG. 6A. The endoscope **12** may then be pulled back until the proximal end of the desired treatment area has been identified and the proximal balloon **22** may be slid over the shaft of the second catheter **20** and inflated (e.g., with chilled, room or body temperature fluid) at a site just proximal to the most proximal portion of the lesion, as shown in FIG. 6B.

With the treatment area **40** now enclosed by these balloons, an optional pressure capsule **42** (e.g., solid state, piezoelectric or other pressure sensing method) may be inflated and the treatment may proceed, as shown in FIG. 6C. The treatment session then exposes the lumen or body cavity to fluid pressurized to a positive pressure in the range of, e.g., 5-100 cmH₂O (although this pressure may be maintained at a level below an inflation pressure of the inflation balloons) at temperatures between, e.g., 50 and 100 degrees Celsius, for a period of, e.g., 1 second to 10 minutes. Additionally and/or alternatively, the treatment area **40** may be lavaged for a period of time with an anesthetic (e.g., lidocaine or bupivacaine) to reduce pain with the procedure prior to the application of thermal energy or other active compounds. Accordingly, ablation may be accomplished at a consistent depth of, e.g., about 0.5 mm, throughout the esophagus ES.

FIGS. 7A to 7C illustrate another example for treatment of an enclosed body cavity (shown here as a bladder BL). In this example, a single balloon may be used to effect infusion and extraction of the treatment fluid. Pressure may be monitored to ensure that the therapy is safe and a relatively lower temperature fluid may be used (e.g., 42-100 C) so that the entire cavity may see a controlled, uniform thermal load. The order or catheter placement may vary as may the sequence for balloon inflation or exposure to active or inactive liquid or vapors in this or any embodiment of the device. As shown in FIG. 7A, an endoscope (or cystoscope) **12** may be inserted into the target organ BL then fluid catheter **20** may be advanced into the lumen. With the endoscope **12** inserted and occlusion balloon inflated **24** (e.g., with unheated fluid) to seal the organ, a pressure sensor **42** may also be optionally inflated, to measure pressure, as shown in FIG. 7B. Optionally, an anesthetic or pre-treatment medication may be delivered into the bladder BL, if so desired. Then, a high or low temperature fluid **80** may be circulated within the bladder BL under pressure adequate to safely distend the organ to ensure complete treatment, as shown in FIG. 7C.

FIG. 8A to 8C illustrate another example for treatment where the use a fluid lavage to prepare the treatment area (here shown as the bladder BL) may be accomplished prior to application of thermal (or cooling) energy and/or active compounds. As previously described, the endoscope **12** and catheter **20** may be introduced into the bladder BL and subsequently sealed with the occlusion balloon **24**, as shown in FIG. 8A and 8B. Preparation of the treatment area may involve use of an anesthetic to decrease pain during therapy or the use of an arterial constrictor to reduce blood flow to the organ or lumen. Alternatively, other pre-treatment fluids **82** may include, e.g., anesthetic, vascular constrictor, chilled fluid, active component antidote, etc. The pre-treatment fluid **82** may be evacuated (or left within the bladder BL) and the lavage with the treatment fluid **80** may be introduced into the bladder BL for treatment, as shown in FIG. 8C,

Alternatively, the pre-treatment fluid **82** may also be chilled (or heated) to cool (or warm) the lumen or organ

prior to treatment so that the thermal (or cooling) energy may be applied to the internal surface of the lumen or body cavity with minimal transmission or conduction of the elevated (or cooling) temperatures to the submucosal tissues (or tissues lining the body organ or lumen). Utilizing the pre-treatment of the area may avoid damage to the underlying tissues to thereby avoid many of the complications of therapy. For example, strictures and/or stenosis (or tightening) of the tissue can be avoided by controlling the depth of penetration which may be controlled by pre-treating the area with a chilled fluid so that the submucosa can absorb significant amounts of heat without reaching damaging temperatures.

The depth of penetration may also be controlled through the use of a lower temperature fluid for thermal ablation so that the submucosa can cool itself with its robust vascular circulation (which is less robust in the mucosa and epithelium), in the event that an active compound is used, as well, an antidote to this compound may be delivered to the patient (either systemically or as a local pre-treatment) so that the underlying tissues and submucosa are not damaged. One example of this is the use of powerful antioxidants (systemically or locally) prior to lavage of the esophagus with, e.g., methotrexate. The methotrexate may have a powerful effect on the tissues to which it is directly exposed in the lumen or body cavity, but the anti-oxidants may prevent deeper penetration of the methotrexate. The neutralizing compound may also be placed within the balloon or in the lumen of surrounding lumens or body cavities to prevent exposure of these areas in the event of balloon rupture.

FIG. 9 shows another example where the distal occlusion member may be configured into an umbrella-like element **90** which may be expanded in the stomach ST and placed over a tissue region which is typically difficult to occlude by a balloon. For instance, such a shape may allow for ablation of the lower esophageal sphincter LES at the gastroesophageal junction (or other sphincter region if used elsewhere). The expandable, umbrella-like structure **90** may form a firm seal at this site while allowing the ablation fluid (hot or cold) to contact the entire gastroesophageal junction. Once expanded, the umbrella-like element **90** may be held firmly against the stomach ST by traction on the endoscope **12** or by a tensioning element on the catheter and balloon itself.

In addition, this element **90** may optionally incorporate a biased or spring-loaded element or other external force mechanism to provide steady pressure and a firm seal against the stomach lining. Alternative structures may also incorporate a more complex, nitinol cage (or other rigid material) connected by a thin, water-tight film. For example, nitinol may be used to decrease the overall profile of the obstruction element and increase its strength and durability.

FIG. 10 shows another example which utilizes an endoscopic balloon sheath utilized as a distal occluder allowing for exposure and treatment of the distal gastroesophageal junction. In this embodiment, the second catheter **20** may have a distal occlusion balloon **100** which may be passed through the working channel of the endoscope **12** or through a channel incorporated into the balloon sheath itself (outside of the actual endoscope). Once expanded into an enlarged shape, the balloon **100** may be retracted to fit entirely over the lower esophageal junction LES to form the distal seal by traction on the endoscope **12** or by a tensioning element on the catheter and balloon itself. This gastric occlusion balloon may allow for exposure of the gastroesophageal junction while preventing fluid flow into the stomach ST. The balloon

22 may be configured to be saddle-shaped, circular, wedge-shaped, etc. It may also be self-expanding and non-inflatable.

Additionally, the proximal balloon 22 may be configured to be part of sheath that is placed over the tip of the endoscope 12 or it may be formed directly upon the endoscope tip itself. An inflation lumen may run inside the endoscope 12 or it may run alongside the endoscope 12 in a sheath or catheter. The balloon sheath may also incorporate a temperature sensor, pressure sensor, etc. Moreover, the proximal occlusion balloon 22 may optionally incorporate a temperature or pressure sensing element for the therapy and it may be positioned either through the working channel(s) of the endoscope 12 or alongside the endoscope 12 within the endoscopic balloon sheath.

In yet another embodiment, in order to reduce the risks associated with fluid flow and lavage, a fluid or gel may be infused into the esophagus between the balloons then heated or frozen in situ in order to provide the desired ablative effect without circulating any fluid or gel. In one example of this configuration, a gel may be infused into the esophagus and pressurized to a safe level (e.g., 30-100 mmHg) which may be then rapidly chilled using, for example, a compressed gas and/or a Peltier junction-type cooling element. The gel may freeze at a temperature below that of water and allow for rapid transmission of the ablative temperature to the tissues being treated. This gel may also be a liquid with a freezing point below that of water in which case the treatment zone may be lavaged with this fluid prior to treatment to remove free water and prevent crystal formation during therapy. Once the therapy has been completed, the gel or liquid may be removed or left in the esophagus to be passed into the stomach. In the event that a Peltier cooling or heating element is used, the polarity may be reversed once therapy is complete in order to reverse the temperature and terminate the ablation session.

The distance from the lower end of the distal most portion of the catheter can be on the order of about 150 mm. The distance between the proximal and distal balloons are adjustable by the operator but can be adjusted, e.g., from as small as 0 mm to as large as 25 cm. The treatment zone may have a range of e.g., 3 to 1.5 cm.

In yet an additional embodiment, an energy generator (e.g., a RF electrode or hot wire or other energy source) may be advanced into the treatment area in a protective sheath to prevent direct contact with body tissues) and energy may be applied to the treatment fluid to heat it to the desired temperature. Once the fluid is adequately heated and enough time has passed to achieve a controlled ablation, the fluid may then be evacuated or neutralized with the influx of colder fluid. This embodiment would allow for a very low-profile design and would not require any fluid heating element outside of the body.

In another variation, the cavity or lumen may be exposed to the hot water at a temperature of less than, e.g., 100 degrees Celsius, but greater than, e.g., 42 degrees Celsius, to allow for easier control of the treatment due a longer treatment period. Ranges for optimal hyperthermic treatment include temperatures between, e.g., 42 and 100 C and exposure periods ranging from, e.g., 15 seconds to 15 minutes. In this embodiment, treatment may be effected with an active (e.g., Methotrexate) or inactive fluid at a temperature of, e.g., 90 degrees C., for a period of, e.g., 5-60 seconds, depending on the depth of penetration desired.

FIG. 11 shows another example of an endoscopic balloon sheath which may be used to provide proximal occlusion of the treatment area 40 and may house one or more of the

temperature and pressure sensors. This variation may incorporate a stirring/agitating or recirculation mechanism 110 incorporated into the device which may actuated within the treatment area 40 once the treatment fluid has been introduced to allow for even cooling/heating. The distal occlusion balloon 100 may be inflated within the stomach ST and pulled proximally with controlled traction against the gastric portion of the lower esophageal sphincter LES, as previously described.

In this example, a chilled liquid lavage (or vapor infusion) may then be initiated and the tissue ablated via freezing. A pre-treatment lavage, e.g., a hypertonic, hyperosmotic saline solution, may be introduced with above freezing temperatures followed by a sub-zero temperature lavage to ablate the tissues within the treatment area 40. The hypertonic, hyperosmotic fluid may achieve temperatures down to, e.g., -40 degrees C., without creating ice crystals in the treatment area 40 due to the pre-treatment lavage removing any free water. The treatment fluid following the pre-treatment lavage may have temperatures of e.g., -2 degrees C. to -40 degrees C., for ablation or more particularly a temperature range of, e.g., -5 degrees C. to -20 degrees C. This temperature range may allow for freezing and crystal formation in the exposed tissues without damaging the underlying submucosa (which is protected by the circulation of body temperature blood that prevents freezing). This temperature range can also be easily achieved with hypersalination of aqueous fluid using sodium chloride and may inhibit any undesired damage to tissues with brief contact. Also, the use of a heavily salinated or other sub-zero solution lavage may provide optimal sealing of the occluding balloons in that any sub-zero temperatures outside of the pre-lavaged treatment zone may form an impaction of ice crystals and prevent any further fluid flow outside of the treatment zone. This hypersalinated water solution is but one freezing solution, though, and any aqueous or non-aqueous liquid or vapor that can be infused and extracted at this temperature could be used. Alternatively, cryoablative fluid can simply comprise nitrous oxide (N₂O) or be formed by cooling ethanol or another aqueous or lipophilic fluid with subzero cooling temps with compressed gas or dry ice. In another alternative, compressed CO₂ or dry ice may be introduced into the fluid (e.g., ethanol, butylenes glycol, propylene glycol, etc) to cool it to, e.g., -50 degrees C. or below.

Despite the potential for toxicity, ethanol may be used for a liquid lavage since ethanol resists freezing down to -118 C and is relatively biocompatible although ethanol is dose dependent for toxicity. A liquid lavage with about 75% to 99.9% ethanol concentrations may be utilized to good effect and have been demonstrated to show that a freeze layer develops very rapidly which also inhibits further ethanol absorption. For instance, a concentration of 95% ethanol may be introduced at a temperature of about, e.g., -80 to -50 degrees C., for a treatment time of about, e.g., 5 minutes, utilizing 0.25 to 0.5 liters of the cryogenic fluid. An ethanol copper composition may also be very useful since ethanol resists freezing, whereas aqueous fluids will freeze and expand thereby moving the metal particle out of direct contact with the tissue.

In the event that nitrous oxide is used as the cryogenic fluid, the nitrous may be introduced through a nozzle or spray at a pressure of, e.g., 600-800 psi, at a temperature of about -88 degrees C. Such a temperature and pressure may be utilized for a treatment time of about, e.g., 3 minutes.

The use of a subzero solution within this range may also allow for fine control of the treatment depth as tissue damage would not begin to occur until a temperature differential of

about 37 degrees C. is achieved (assuming a body temperature of 37° C.), but once this threshold is reached tissue damage occurs rapidly due to ice crystal formation in contrast, tissue damage is on a continuous spectrum with hyperthermia and damage may begin to occur at a temperature differential of, e.g., 5 degrees C. Thus, the ability of the vasculature to protect the underlying tissues from damage is greatly reduced due to the small difference between the temperature of protective blood versus the temperature of the ablating, fluid. With hypothermic lavage, the protective blood may differ by, e.g., 37 degrees C., in temperature and may thus allow for control of ablation depth based on the temperature of the fluid lavage and the time of exposure.

FIG. 12 illustrates another variation where a conforming balloon 111 having an adjustable size in diameter as well as in length may be positioned along or near the distal end of the catheter 18. The conforming balloon 111 may be advanced within the esophagus (shown here in the esophagus but applicable to any cavity) in a collapsed state. Once the balloon 111 has been desirably positioned along the length of the esophagus ES to be treated, the catheter 18 may optionally utilize a vacuum which may be drawn along the entire length of the balloon 111 through perforations or openings in the balloon 111 to serve as a safeguard to prevent migration of ablation liquid, gas, and/or conductive material in the event of balloon rupture. The vacuum may also be utilized to remove air, fluids or particulate between the outer wall of the balloon 111 and the tissue to improve contact and thermal transfer from the hyperthermic or cryogenic fluid and to the tissue. Additionally and/or alternatively, a distal vacuum may be drawn through a distal port 117 distal to the balloon 111 either alone or in conjunction with a proximal vacuum port. 115 proximal to the balloon 115.

With the catheter 18 and balloon 111 desirably positioned for treatment, an insulating sheath 113 may be advanced over the catheter 18 and over the length of the balloon 111 to vary an inflation length of the balloon 111 emerging from the insulating sheath 113. The variable length of the inflated balloon 111 may be adjusted to allow for treatment of any varying lengths of the esophagus ES during a single ablation treatment. Such a design may prevent dangerous ablation overlap zones of ablated tissue.

The balloon 111 itself may be comprised of a compliant or non-compliant material but in either case be capable of directly contacting the tissues to be ablated. The balloon 111 may accordingly be filled with a hyperthermic or cryogenic material and/or may use liquid, gas, and/or conductive solids, as described herein.

Although illustrated esophageal therapy, this therapy could be used in any body cavity/lumen for therapeutic purposes including, but not limited to, gastrointestinal therapy, stomal tightening (e.g., post bariatric surgery), urogynecologic uses (treatment of cervical pre-cancers or cancers, endometrial lining treatment, stress incontinence therapy), prostate therapy, intravascular therapy (e.g., varicose veins) or treatment of any other body cavity/lumen, in the event that an entire body cavity is being treated (e.g., the entire uterus) a single balloon system may suffice to exclude the entire cavity. The fluid cycling or dwell may then be accomplished with use of a pressure-controlled exposure of the cavity or lumen.

FIGS. 13A and 13B show another example of how the system may be introduced into, e.g., a uterus UT, through the cervix for treatment via the lavage catheter 20. In this example, the catheter 20 may have a diameter of about, e.g., 8 mm, or in other examples, a diameter of about, e.g., less

than 6 mm. Infusion of the lavage fluid may fully distend or partially distend the uterine walls. Optionally, catheter 20 may incorporate a tip 120 to perform one or more functions including, e.g., an expandable cage or scaffold to prevent direct exposure of a cryoprobe to the tissue walls of the uterus UT, an agitator or recirculator to ensure even distribution of cryoablation effect, etc. As previously described, the system may be used with lavage or with infusion then cryoprobe chilling of fluid in an alternate embodiment, infusion of an antifreeze fluid and insertion of the cryoprobe may be done separately with chilling of the anti-freeze done after the cryoprobe insertion.

In this and other examples, the therapy may be guided by time/temperature tracking or visualization (e.g., hysteroscope, endoscope, ultrasound, etc.). Pressure may be regulated by a pressure sensor in line with the infusion or extraction lumen or a dedicated pressure lumen in a multi-lumen catheter. Additionally, pressure may also be regulated by limiting infusion pressure (e.g., height of infusion bag, maximum pressure of infusion pump, etc). Any organ, body cavity or lumen may be treated using the described lavage and/or infusion/cryoprobe technique described here for the uterus.

FIGS. 14A and 14B illustrate another variation of a treatment system which utilizes a thermally conductive array of fibers, cage, or lattice 130 which may be deployed within the uterus UT. In this variation, the endoscope 12 may be advanced through the cervix and at least partially into the uterus UT where the array of fibers or lattice 130 may be deployed from the endoscope 12 distal end where the array 130 may be positioned in a compressed state for delivery, as shown in FIG. 14A. The array 130 may advanced into the uterus UT where it may then be expanded into a deployed configuration 130', as shown in FIG. 14B. The individual cryogenic probes of the expanded array 130' may be in fanned out relative to the distal end of the endoscope 12 in various directions to come into direct contact or close proximity to the tissue to be treated.

Following deployment, the deployed array 130' may be cooled rapidly to transmit the heat within the uterine walls to the array 130' to provide a consistent cryoablative effect throughout the body cavity or lumen. The members of the array 130' may be cooled either via conductive cooling or by an infusion of a cooling fluid (as described herein) through the members of the array 130'. Similar to the conductive fluid, the cooled array 130' may provide for the consistent ablation of the entire lumen with a single application of the array 130'. The individual members of the array 130'

Additionally and/or alternatively, the array 130' may be used in conjunction with a fluid infusion and/or lavage in order to optimize therapy. One or more sizes and shapes of the array 130' may be available depending on the size and shape of the cavity to be treated. Moreover, the array 130' may be formed from any material so long as it has a thermal conductivity greater than, e.g., 2 W/m-K, such as a metal with a relatively high thermal conductivity.

FIG. 15 shows another variation of a device which may utilize cryogenic lavage treatment within the uterus UT. In this example, the distal end of the endoscope 12 may be advanced through the cervix CV and into the uterus UT where a cryoprobe 140 may be deployed, as shown. One or more inflatable balloons 144 may be expanded, e.g. within the external os, or a balloon 142 along the outer surface of the endoscope 12 may be inflated within the length of the os itself. Alternatively, a single balloon (e.g., having an hour-glass or dumbbell shape) may be inflated to block both the external os and the length of the os itself With the uterus UT

obstructed, the cryogenic treatment or lavage may be performed within the uterine lumen.

Another variation is illustrated in FIG. 16 which shows endoscope 12 advanced through the cervix CV with the distal end 156 positioned within the uterine lumen. An optional balloon 152 located near the endoscope distal end may be inflated within the uterus UT and then pulled proximally against the internal os with a fixed amount of tension to obstruct the opening. Additionally and/or alternatively, a proximal balloon 154 positioned along the endoscope 12 proximally of where the cervix CV is located may also be inflated to further provide for obstruction of the entire os. Then external cervical engagement portion, e.g., proximal balloon 154, may be fixed in place relative portion of the endoscope 12 spanning the cervical os to provide consistent tension. The proximal balloon 154 may also have a spring-type function to provide for consistent tension regardless of tissue relaxation and accommodation.

With the uterus UT obstructed, the endoscope 12 may then be used to provide for the cryogenic, treatment or lavage. Optionally, the endoscope 12 may also incorporate one or more vacuum ports along the length of the shaft to seal and provide a safeguard against fluid flow out of the uterus UT.

Optionally, the uterine cornu may be temporarily obstructed to block the openings of one or both Fallopian tubes prior to the cryogenic treatment. The occlusive element(s) 158A, 158B may comprise, e.g., balloons, inserts, energy-based ablation to contract the aperture, hydrophilic or hydrophobic gel-based solutions, or any other modality that is capable of reversibly or irreversibly sealing the Fallopian tube. The optional Fallopian tube occlusion may be temporary or permanent (if sterility is desired).

Once the cryogenic procedure has been completed, the occlusive elements 158A, 158B may be removed or allowed to passively erode. Alternatively, they may be left occluded for those desiring sterility. Occluding the uterine cornu prior to a lavage may allow for greater fluid pressure and fluid flow within the uterus UT.

FIGS. 17A and 17B illustrate another variation of a low-pressure conforming balloon. In this variation, a conforming balloon 160 may be deployed from the distal end 156 of the endoscope 12 and then inflated with the cogenic liquid/gas (as described herein) while in uterus UT. The balloon 160 may be formed to resist rupture at low and high temperatures and may be further configured to conform well to the anatomy of the uterus UT. For example, the balloon 160 when inflated may have a shape which approximates the lumen in which it is inflated and/or come in various sizes to accommodate different patient anatomies. In the present example, the expanded balloon 160' may be formed to taper and have two portions rounded portions for expanding into intimate contact at the uterine cornu UC, as shown, without painful deformation or distention of the uterus UT at a pressure, e.g., less than 150 mmHg.

Moreover, the expanded balloon 160 may have a wall which is relatively thin (e.g., 0.040 in. or less) to facilitate thermal conduction through the balloon. The balloon 160 may also be sufficiently thin such that folding of the balloon 160 on itself does not create a significant thermal barrier allowing for an even ablation in the event that a non-compliant balloon is used. For treatment, the expanded balloon 160' may be filled with the cryogenic liquid, gas or a thermally conductive compound (as described above) to subject the contacted tissue to either cryogenic and/or hyperthermic injury (e.g., steam, plasma, microwave, RF, hot water, etc). Additionally and/or alternatively, the balloon

160' may also be used to transmit photodynamic therapy light to the uterus UT or esophagus ES. This modality may be used to achieve ablation of any body cavity or lumen.

Additionally, one or more vacuum ports may be used anywhere along the length of the shaft to seal and provide a safeguard against fluid flow out of the uterus UT in the event of balloon rupture. Additionally, one or more inflatable os balloon 160 may also be used to block the internal or external os, as also described above.

In another variation, to facilitate the balloon expanding and conforming readily against the tissue walls of the uterus UT, the balloon may be inflated with a gas or liquid. Alternatively, as shown in FIGS. 18A to 18D, the balloon may be filled partially or completely with a conductive material. As shown in FIG. 18A, once the elongate shaft 170 has been introduced through the cervix CV and into the uterus UT, the distal opening 172 of the shaft 170 may be deployed either from within the shaft 170 or from an external sheath (described below in further detail). The balloon may be deployed and allowed to unfurl or unwrap within the uterus UT, as shown in FIG. 18B. The cooling probe 178 may be introduced through the shaft 172 and into the balloon interior (or introduced after insertion of the conductive elements).

Because the balloon 174 is used to contact the tissue and thermally conduct the heat through the balloon, the balloon material may be comprised of various materials such as polyurethane, fluorinated ethylene propylene (FEP), polyether ether ketone (PEEK), low density polyethylene, polyethylene terephthalate (PET), polyvinylidene fluoride (PVDF), or any number of other conformable polymers. Moreover, the balloon material may have a thickness which remains flexible and strong yet sufficiently thermally conductive, e.g., about 0.0005 to 0.015 in. Such a thickness may allow for the balloon to remain supple enough to conform desirably to the underlying tissue anatomy and may also provide sufficient clarity for visualizing through the material with, e.g., a hysteroscope.

The conductive elements 182 may be introduced into the balloon interior through an annular opening 180 within the distal end 172 of the shaft, as shown in FIG. 18C, until the balloon 174 is at least partially or completely filled with the elements 182. The conductive elements 182 may generally comprise any number of thermally conductive elements such as copper spheres or some other inert metal such as gold. These conductive elements 182 may be atraumatic in shape and are small enough to fill the balloon interior and conform the balloon walls against the uterine walls UW to ensure consistent contact with the tissue, e.g., about 20 ml in volume of the elements 182. The conductive elements 182 may also help to fill any air pockets which may form particularly near the tapered portions 176 of the balloon and insulate the tissue from the ablative effects of the cryoablative fluid. For instance, the conductive elements 182 may be thinned into spheres having a diameter of e.g., 0.8 mm to 4 mm or larger. To ensure that that conductive elements 182 are fully and evenly dispersed throughout the balloon interior, the elements 182 may be introduced through the shaft 170 via an ejector or push rod, auger, compressed air, etc. In particular, the conductive elements 182 may fill the tapered portions 176 of the balloon 174 to ensure that the balloon is positioned proximate to and in contact with the uterine cornu UC to fully treat the interior of the uterus UT, as shown in FIG. 18D.

With the conductive elements 182 placed within the balloon 174, the cryoablative fluid may be introduced within

and through the balloon 174 such that the conductive elements 182 facilitate the thermal transfer from the contacted uterine walls UW. Once the cryoablative treatment has been completed, the conductive elements 182 may be removed through the shaft 170 via a vacuum force or other mechanical or electromechanical mechanisms and the balloon 174, once emptied, may also be withdrawn from the uterus UT.

The cooling probe 178 introduced into the interior of the balloon 174 may comprise a number of different configurations which facilitate the introduction of the cryoablative fluid into the balloon 174. One such variation, similar to the variation shown above in FIG. 14B, is illustrated in the detail view of FIG. 19 this variation, the shaft 178 may have one or more cooling members 190A, 190B, 190C, 190D which project from the distal end of the shaft 178 at various angles. Although illustrated with four cooling members extending from the shaft 178, any number of cooling members may be used at a variety of different angles and lengths as desired. Moreover, the cooling members may be fabricated from a number of materials, e.g., polyimide, Nitinol, etc., which are sufficiently strong and temperature resistant for the relatively low temperature of the fluid. Each of the cooling members 190A, 190B, 190C, 190D in this example may each have an occluded tip 192 and at least one opening 194 defined along the side of the cooling member. The cryoablative fluid may be flowed through the shaft 178 and into each cooling member where the fluid may then be sprayed or ejected through the respective openings 194 for distribution throughout the interior of the balloon for cooling the contacted uterine tissue.

Another variation of the cooling probe is illustrated in the detail view of FIG. 20 which shows elongate shaft 178 having a rotating, base 200 and spray member 202 positioned upon shaft 178. The spray member 202 may have a surface which is meshed, latticed, perforated, etc. such that the cryoablative fluid introduced through the shaft 178 may enter the rotating base 200 and spray member 202 where it may be evenly dispersed through the spray member 202 and into the interior of the balloon 174 for treatment. The pressure of the fluid may rotate the base 200 about its longitudinal axis, as shown, to further facilitate the distribution of the cryoablative fluid within the balloon 174.

The cooling probe 178 as well as the balloon assembly may be variously configured, for instance, in an integrated treatment assembly 210 as shown in the side view of FIG. 21A in this variation, the assembly 210 may integrated the elongate shaft 170 having the balloon 174 extending therefrom with the cooling, probe 178 positioned translatably within the shaft 170 and balloon 174. A separate translatably sheath 212 may be positioned over the elongate shaft 170 and both the elongate shaft 170 and sheath 212 may be attached to a handle assembly 214. The handle assembly 214 may further comprise an actuator 216 for controlling a translation of the sheath 212 for balloon 174 delivery and deployment. The sheath 212 may be configured to have a diameter of, e.g., 5.5 mm or less, to prevent the need for dilating, the cervix.

With the sheath 212 positioned over the elongate shaft 170 and balloon 174, the assembly 210 may advanced through the cervix and into the uterus UT where the sheath 212 may be retracted via the handle assembly 214 to deploy the balloon 174, as shown in FIG. 21B. As described above, once the balloon 174 is initially deployed from the sheath 212, it may be expanded by an initial burst of a gas, e.g., air, carbon dioxide, etc., or by the cryogenic fluid. In particular, the tapered portions of the balloon 174 may be expanded to

ensure contact with the uterine cornu. The handle assembly 214 may also be used to actuate and control a longitudinal position of the cooling probe 178 relative to the elongate shaft 179 and balloon 174 as indicated by the arrows.

FIG. 22A shows an example of one variation of a design of a system which may be used to deploy the balloon 174 into the uterus LIT after properly setting the depth of the uterine cavity (or some other anatomical measurement). The elongate shaft 170 may have the balloon 174 attached along or near the distal end of the shaft 170 via a clamp or O-ring 171 placed along the outside of the shaft 170. One or more indicators 173 along the outer surface of the cannula may correspond to clinical measurements of the uterine length which may be measured by the clinician prior to a cryoablative procedure. With the measured uterine cavity known, the balloon 174 may be adjustably clamped along the length of the shaft 179 at any one of the indicators 173 which may correspond to the measured cavity length. With the balloon 174 suitably clamped in place, it may be pushed into the shaft lumen, as shown in FIG. 22B, using a pusher or some other instrument for delivery into the uterus UT. The elongate shaft 170 and balloon 174 may then be introduced into the uterus UT where the balloon 174 may be deployed from the shaft 170 and having a suitable length which may correspond to the particular anatomy of the patient.

The cooling, probe positioned within the balloon 174 may be variously configured, as described above, and may include further variations. As illustrated in the perspective and side views of FIGS. 23A and 23B, respectively, the cooling probe assembly 220 in this variation may comprise an exhaust catheter 222 which may define a lumen 224 therethrough. While the diameter of the exhaust catheter 222 may be varied, its diameter may range anywhere from, e.g., 4.5 to 4.75 mm. The exhaust catheter 222 may be formed from various materials, such as extruded polyurethane, which are sufficiently flexible and able to withstand the lowered treatment temperatures. The distal end of the catheter 222 may have an atraumatic tip 226 which may be clear and/or which may also define a viewing window or opening through which an imaging instrument such as a hysteroscope 246 may be positioned. One or more supporting members or inserts 228, e.g., made from a polymer such as polysulfone, may be positioned throughout the length of the lumen 224 to provide structural support to the catheter 222 and to prevent its collapse. The inserts 228 have a relatively short length and define a channel therethrough through which a probe support 230 (e.g., flat wire, ribbon, etc.) may extend. The probe support 230 shown in this variation may comprise a flat wire defining one or more notches 232 along either side which may lock with one or more of the inserts 228 via insert supports 240 to stabilize the probe support 230.

The probe support 230 itself may be fabricated from a material such as stainless steel and may have a thickness of, e.g., 0.008 in. The probe support 230 may be supported within the lumen 224 via the inserts 228 such that the probe support 230 separates the lumen 224 into a first channel 242 and a second channel 244 where the cooling lumens 236 may be positioned along the probe support 230 within the second channel 244 while the first channel 242 may remain clear for the optional insertion of a hysteroscope 246. In the event that a hysteroscope 246 is inserted within first channel 242, the hysteroscope 246 may be advanced selectively along the catheter lumen 224 for visualizing the surrounding tissue or the hysteroscope 246 may be advanced through the length of the catheter 222 until it is positioned within a scope receiving channel 238 defined within the catheter tip 226.

Because of the thickness of the probe support **230** relative to its width, the probe support **230** may be flexed or curved in a single plane, e.g., in the plane defined by the direction of flexion **254** shown in FIG. **23B**, while remaining relatively stiff in the plane transverse to the plane defined by the direction of flexion **254**. This may allow for the probe **220** to be advanced into and through the patient's cervix CV and into the uterus UT while conforming to any anatomical features by bending along the direction of flexion **254** (e.g., up to 90 degrees or more) but may further allow the probe **220** to maintain some degree of rigidity and strength in the transverse plane. Additionally and/or alternatively, the catheter **222** may be actively steered along, the direction of flexion **254**, e.g., via one or more pullwires, to allow for positioning or repositioning of the catheter **222** within the balloon **174** to facilitate fluid distribution and/or visualization.

The probe **220** may further include one or more cooling lumens **236** which are positioned along the probe support **230** within the second channel **244**. In this example, at least two cooling lumens are used where a first cooling lumen may extend through the probe **220** and terminate at a first cooling lumen termination **248** near the distal tip **226** and a second cooling lumen may also extend through the probe **220** adjacent to the first cooling lumen and terminate at a second cooling lumen termination **250** at a location proximal to the first termination **248**. The termination points may be varied along the length of the probe **220** depending upon the desired length of the active cooling portion **252** of the probe **220**, which may extend from the distal tip **226** to a length ranging anywhere from, e.g., 2 to 14 cm, along the probe length.

The cooling lumens **236A**, **236B** may be fabricated from any number of materials suitable to withstand the low temperature fluids, e.g., Nitinol, polyimide, etc. Moreover, the internal diameter of the cooling lumens may be made to range anywhere from, e.g., 0.010 to 0.018 in. In certain variations, the cooling lumens may have an outer diameter of, e.g., 0.020 in., and an internal diameter ranging from, e.g., 0.016 to 0.018 in., with a wall thickness ranging from, e.g., 0.002 to 0.004 in.

Because the cooling lumens **236** are located along the second channel **244**, as separated, by the probe support **230**, one or more windows or openings **234** may be defined along the length of the probe support **230** to allow for the passage of any cryoablative fluid to pass through the openings **234** and to then directly exit the catheter **222** through the openings **260** defined along the catheter **222** body (as described below) and into the balloon interior. Alternatively, the cryoablative fluid may instead proliferate through the entire lumen **224** defined by the catheter **222** before exiting the catheter **222** body. These openings **234** may be cut-outs through the probe support **230** and may number anywhere from zero openings to six or more, as shown, and they may be configured in any number of sizes and shapes. Moreover, these openings **234** may be distributed in any spacing arrangement or they may be uniformly spaced, e.g., 0.320 in., depending upon the desired cooling arrangement.

The number of cooling lumens **236** may also be varied to number more than three lumens terminating, at different positions along the active portion **252**. Additionally, the activation of the cooling lumens for spraying, or introducing the cryoablative fluid may be accomplished simultaneously or sequentially from each of the different cooling lumens depending upon the desired ablation characteristics. While the cooling lumens may simply define a distal opening for passing the fluid, they may be configured to define several

openings along their lengths to further distribute the introduction of the cryoablative fluid. The openings **260** along the catheter body **222** for venting the cryoablative fluid into the balloon **174** are omitted from FIG. **23A** only for clarity purposes but are shown in further detail in the following FIG. **24**.

As the cryoablative fluid is initially introduced into the catheter lumen **242**, the exhaust catheter **222** may also define one or more openings to allow for the cryoablative fluid to vent or exhaust from the catheter interior and into the interior of the balloon **174**. As shown in the perspective view of FIG. **24**, one or more openings **260** are illustrated to show one example for how the openings **260** may be defined over the body of catheter **222**. The openings **260** may be positioned along, a single side of the catheter **222** or they may be positioned in an alternating transverse pattern, as shown, to further distribute the cooling fluid throughout the balloon interior. In either case, the positioning of the openings **260** may be varied depending upon the desired cryoablation characteristics.

A cross-sectional end view of the cooling probe assembly **220** is shown in FIG. **25A** illustrating the relative positioning of supporting insert **228** attached to the probe support **230** within the catheter **222**. The two cooling lumens **236A**, **236B** are illustrated adjacently positioned along the probe support **230** although they may be positioned elsewhere within the catheter **222** and may also number one lumen or greater than two lumens. Moreover, an optional hysteroscope **246** is also illustrated positioned within the catheter **222** along the probe support **230**. An end view of the distal tip **226** is also illustrated in FIG. **25B** showing one variation where the distal tip **226** may define a viewing window **270** through which the hysteroscope **246** may be advanced for visualizing within the balloon **174** and uterus UT. In other variations, the viewing window **270** may be omitted and the distal tip **226** may be transparent for allowing visualization directly through the tip **226** by the hysteroscope **246**.

With such an arrangement of the cooling probe assembly **220** positioned within the balloon **174** (as illustrated above in FIG. **21B**), the assembly **210** may be used to treat the surrounding uterine tissue in close conformance against the balloon **174** exterior surface. Introduction of the cryoablative fluid, e.g., nitrous oxide, through the cooling probe **220** may allow for the ablation of the surrounding tissue to a depth of, e.g., 4 to 8 mm.

One example for a treatment cycle using a two cycle process may include the introduction of the cryoablative fluid for a treatment time of two minutes where the surrounding tissue is frozen. The fluid may be withdrawn from the balloon **174** and the tissue may be allowed to thaw over a period of five minutes. The cryoablative fluid may be then reintroduced and the tissue frozen again for a period of two minutes and the fluid may then be withdrawn again to allow the tissue to thaw for a period of five minutes. The tissue may be visually inspected, e.g., via the hysteroscope **246**, to check for ablation coverage. If the tissue has been sufficiently ablated, the assembly **210** may be removed from the uterus UT, otherwise, the treatment cycle may be repeated as needed. In other alternatives, a single cycle may be utilized or more than two cycles may be utilized, as needed, to treat the tissue sufficiently. Furthermore, during the treatment cycle, a minimum pressure of e.g., 40 to 80 mm Hg, may be optionally maintained by the cryogenic liquid or by a gas (e.g., air, carbon dioxide, etc.) to keep the balloon **174** and uterus UT open.

In yet another alternative, aside from having a catheter **222** made as an extruded lumen, the catheter may be formed

into tubing **201** such as a hypotube fabricated from a material such as, e.g., stainless steel, nitinol, etc. A tubing **201** formed from a metal may provide additional strength to the catheter and may remove the need for any inserts to maintain a patent lumen. To increase the flexibility of the tubing **201**, one or more slots **203** may be formed or cut along the body of the tubing **201**, as shown in the example of FIG. **26A**, which illustrates a perspective view of tubing **201** having one or more slots **203** cut transversely relative to the tubing **201**. Aside from increased flexibility, the slots **203** may be aligned to provide for preferential bending or curvature along predetermined planes by the tubing while inhibiting the bending or curvature along other planes e.g., planes transverse to the bending plane, similar to the preferential bending or curvature provided by the probe support **230**.

The ends of the slots **203** may be formed to provide a separation **205** between the ends of the slots **203**. FIG. **26B** shows another variation where each of the transverse slots **203** may have a strain relief feature **207** formed at the distal ends of each slot **203** such that bending of the tubing **201** over the slotted region may occur with reduced stress imparted to the slots **203** and tubing **201**. An additional feature may include optional tabs **209** which may be formed along the body of the tubing **201** to extend internally for holding a cooling lumen within the lumen of the tubing **201**.

Another variation is shown in FIG. **26C** which shows transverse slots **203** formed along the body of the tubing **201** where the slots **203** may be formed in an alternating pattern with respect to one another. FIG. **26D** shows yet another variation where angled slots **211** may be formed relative to tubing **201**. FIG. **26E** shows another variation having one or more serpentine slots **213** for preventing pinching where a distal end of each slot **213** may have a transverse slot **215** formed. FIG. **26F** shows another variation where one or more slots **217** having a transverse and longitudinal pattern may be formed along tubing **201**.

FIG. **26G** shows another variation where a transverse slot **219** may have a longitudinal slot **221** formed at its distal end. FIG. **26H** shows yet another variation where one or more tapered slots **223** may be formed along tubing **201**. FIG. **26I** shows another variation where a transverse slot **219** may have a longitudinal slot **221** formed where each of the longitudinal slots **221** may be aligned longitudinally along the body of tubing **201**. FIG. **26J** shows another variation where transverse slots **219** may have longitudinal slots **223** aligned adjacent to one another and having rounded ends. FIG. **26K** shows another variation where either a curved serpentine slot **225** or an angled slot **227** may be formed along the tubing **201**. Alternatively, both curved serpentine slot **225** and angled slot **227** may both be formed. Another variation shows tubing **201** having a plurality of slots **229** formed into a lattice structure over the body of tubing, **201**.

Aside from utilizing a continuous body of tubing **201** for the length of the cooling probe, discrete tubing reinforcing ring **231** may instead be formed from tubing **201**. FIG. **27A** shows an example where a plurality of reinforcing rings **231** may be separated into discrete ring elements and attached to one another in a linear manner with one or more longitudinal beam members **233** which may be attached to each reinforcing ring **231** at an attachment point **235**, e.g., weld, adhesive, etc. One or more of the reinforcing rings **231** may be formed to have, e.g., a bent-in tab **237**, for supporting beam **233** rather than utilizing, a weld, adhesive, etc., as shown in the detail perspective view of FIG. **27B**. The

assembly of the reinforcing ring **231** and beams **233** may be covered with a membrane or other covering to form a uniform structure.

An example of a covering which may be used is shown in the end view of FIG. **28A** which shows a portion of tubing **201** or reinforcing ring **231** and cooling lumens **236** positioned on either side of tubing **201** or reinforcing ring **231**. A heat shrink **241** material may be placed over the probe assembly while maintaining clearance for openings **239** to allow for delivery of the cryoablative fluid.

Another variation is shown in the cross-sectional end view of FIG. **28B** which shows the tubing **201** and respective cooling lumens **236** positioned within an insert **243** which define insert openings **245** for introducing the cryoablative fluid. Yet another variation is shown in the perspective view of FIG. **29** which may incorporate a wound spring **247** which may be tightly wound or packed to provide flexibility and to further provide a lumen **249** for the exhaust. One or more inserts **243** may be positioned longitudinally along the length of the spring **247** and the cooling lumens **236** may be routed through the spring **247** and coupled to each insert **243**.

Another variation is shown in the partial cross-sectional side view of FIG. **30A** which illustrates how one or more inserts **243** may each define a step **251** for securement to the spring **247**. The entire assembly may then be covered by a covering **253**, e.g., flexible extrusion. Each of the inserts **243** may remain uncovered by either the spring **247** or covering **253** to ensure that the cryoablative fluid has an unhindered pathway to the balloon interior. FIG. **30B** shows another variation where each of the inserts **243** may define a respective receiving channel **257** on either side of the insert **243** for securement to the spring **247**. An example of a cooling lumen **236** is shown attached to each of the inserts **243** via an attachment **255**, weld, adhesive, etc.

Aside from increasing the flexibility of the tubing or cooling probe, the cooling lumen may be configured to increase its flexibility as well. An example is shown in FIG. **31** which shows a portion of a cooling lumen wall **261** having a plurality of pivoted attachments **263**. Such an arrangement may allow for each segment of the cooling lumen wall **261** to pivot such that the cooling lumen cumulatively provides sufficient flexibility to bend and curve as the cooling probe assembly is advanced and positioned within the uterus. Such a cooling lumen may be incorporated into any of the probe variations described herein.

Another example of a cooling probe assembly is illustrated in the perspective view of FIG. **32** which shows discrete embedded insert **265** and one or more cooling lumens **236** attached to each respective insert **265** covered with a covering **267**. In this example, the covering **267** may be implemented without any additional features or structures. FIG. **33** shows yet another example where individual inserts **265** may be aligned and coupled with one or more beams **233**, as previously described. An additional sliding joint **269** may be attached or integrated along each insert **265** to provide support to one or more cooling lumens **236** which may be translationally positioned through each aligned sliding joint **269**.

Yet another variation is illustrated in the side view of FIG. **34** which shows a wound spring element **271** having one or more cooling lumens **236** aligned longitudinally along the spring element **271**. The one or more cooling lumens **236** may be attached to the spring element **271** via connectors **273** which may be aligned relative to one another to receive and secure the cooling lumens **236**. A covering may be optionally secured over the spring assembly.

FIG. 35 shows another variation where spring element 271 may incorporate one or more respective inserts 243. In this variation, the spring element 271 have the one or more cooling lumens 236 coupled to the spring element 271 itself. FIG. 36 shows yet another variation where the spring element 271 and the one or more cooling lumens 236 (which may be coupled directly to the spring element 271), may have an optional secondary lumen 275 passing through the spring element 271 and optionally attached to the spring itself. The second lumen 275 may be sized for receiving an instrument such as a hysteroscope 246. The second lumen 275 may provide a redundant liquid or gas pathway should the primary lumen become partially or fully obstructed. The redundant pathway may exist between the optional instrument, e.g. hysteroscope, and primary lumen or within the full second lumen 275.

The secondary lumen 275 may be shown in various cross-sections in the end views of FIG. 37. A first variation is illustrated shown secondary lumen 275 having a circular cross-sectional area with a hysteroscope 246 passed through a center of the lumen 275. A second variation is illustrated where the hysteroscope 246 may be passed along a side of the lumen 275 and a third variation is illustrated showing a secondary lumen 275A having an elliptical cross-sectional area.

Another variation for a cooling probe assembly is shown in the perspective views of FIGS. 38A to 38C. In this variation, the catheter body 222 is omitted for clarity purposes only but a main delivery line 280 is shown extending through the catheter with at least two side delivery lines 282, 284 positioned near the surface of the catheter body, as shown in FIG. 38A. The main delivery line 280 may be in fluid communication with the side delivery lines 282, 284 via a junction 288, shown in FIG. 38B, near or within the distal tip 226. As the cryoablative fluid is introduced into the main delivery line 280, the fluid in the side delivery lines 282, 284 may be vented through one or more openings 286 defined therealong for venting through and into the catheter and balloon interior. An optional mandrel 290, as shown in FIG. 38C, may be slidably fitted within each of the side delivery lines 282, 284 and actuated automatically along with the retraction of the sheath 212 or by the user to slide along the interior of one or both side delivery lines 282, 284 to selectively obstruct the openings 286 and thereby control the amount of cryoablative fluid delivered. As shown, one or more obstructed openings 292 may be blocked by the mandrel 290 by selectively sliding the mandrel 290 accordingly. In other variations, rather than using mandrels inserted within the delivery lines 282, 284, a sheath or mandrel placed over the delivery lines 282, 284 may be used instead to achieve the same results.

As described above, the retraction of the mandrel 290 may be optionally actuated to follow along with the retraction of the sheath 212. Accordingly, the retraction of the mandrel 290 may occur simultaneously with the retraction of the sheath 212 but the retraction may optionally occur at different rates as the amount of cryoablative fluid delivered may be related to the length of the uterine cavity to be treated. For instance, a sheath retraction of, e.g., 7 cm, may result in 10 unobstructed openings 286 whereas a sheath retraction of, e.g., 4 cm, may result in e.g., 6 unobstructed openings 286.

Another variation of the cooling probe assembly is illustrated in the detail cross-sectional side view of FIG. 39. In this variation, a single main delivery line 280 may pass through and into communication with distal tip 226. Rather than having the side delivery lines 282, 284 coupled directly

to the main delivery line 280, each respective line may be coupled to a common chamber 301 defined within the distal tip 226. Such an assembly may be used with alternative variations of the exhaust lumen 303 as shown in one example in the cross-sectional end view of FIG. 40A. In this example, the exhaust lumen 303 may be formed to have an indented cross-sectional area to accommodate the side delivery lines 282, 284. Alternatively, the exhaust lumen 303 may be shaped to have an elliptical cross-sectional area instead, as shown in FIG. 40B.

In yet another alternative, the cooling lumens may be formed to have a single introduction or infusion line 305 and a single delivery line 307 where the delivery line 307 may be in fluid communication directly with the introduction or infusion line 305 through the distal tip 226, as shown in the cross-sectional side view of FIG. 41. The infusion line 305 and delivery line 307 may be formed as separate lines or they may be formed as a single continuous line where the infusion line 305 enters distal tip 226 and is curved to redirect the ablative fluid proximally through the delivery line 307, in this variation, as in the previous variations, a translatable mandrel 290 may be slidably positioned within the delivery line 307 or optionally along an outer surface of the delivery line 307 to selectively obstruct the openings 286 defined along the line 307. In other variations, one or more openings may also be optionally aligned along the infusion line 305 in addition to the openings 286 along delivery line 307. Moreover, the mandrel 290 may be actuated to slide (either at the same or different rate) along with the retraction of the sheath. FIG. 42 illustrates an example where the cooling probe assembly may be introduced into the interior of balloon 174 when deployed within the uterus UT. Alternatively, the balloon 174 may be attached directly along an outer surface of the cooling probe assembly itself. The expanded length of balloon 174 may be fixed along, the outer surface of the cooling probe assembly proximal to the distal tip or it may be optionally adjustable via the positioning of the outer sheath. As shown, the introduction line 305 may introduce the cryoablative fluid along the cooling probe assembly where it may then be flowed proximally along the delivery line 307 for introduction into the interior of the balloon 173. As the cryoablative fluid is introduced, a slotted tube 311 having, one or more directional slots 313 may be used to optionally direct the flow of the cryoablative fluid into the balloon interior.

FIGS. 43A and 43B illustrate additional variations for selectively controlling the configuration of the hole directions along the side delivery lines to optionally control appropriate ablation depths and tapering, as needed or desired. In the variation of FIG. 43A, the adjacent side delivery lines 282, 284 from the distal tip 226 may be configured such that openings 300 are configured in an up/down configuration, openings 302 are configured in an down/up configuration, openings 304 are configured in an left/right configuration, openings 306 are configured in an up/down configuration, and openings 308 are configured in an down/up configuration. The hole directions of up/down/left/right are relative to the figures shown and are presented for illustrative purposes.

Likewise, the variation shown in FIG. 43B illustrates how the adjacent side delivery lines 282, 284 may be configured such that openings 310 are configured in an up/down configuration, openings 312 are configured in an left/right configuration, openings 314 are configured in an down/up configuration, openings 316 are configured in an left/right configuration, and openings 318 are configured in an up/down configuration. These variations are illustrated as

exemplary variations and other variations of hole directions may be accomplished as desired.

Aside from the positioning of the fluid openings, the catheter body 222 itself may optionally incorporate a skived viewing window 320, as shown in the side view of FIG. 44, to facilitate visualization of the surrounding balloon 174 and tissue by the hysteroscope 246 which may be advanced into proximity to the window 320 or entirely through as desired.

As previously described, the balloon 174 may be expanded within the uterus UT and particularly into the uterine cornu UC by an initial burst of gas or liquid. Other mechanisms may also be used to facilitate the balloon expansion. One variation is shown in FIG. 45 which illustrates a balloon 174 having one or more supporting arms 330A, 330B extending from a support 334 which may be deployed within the balloon 174. The supporting arms 330A, 330B may be variously configured although they are shown in this example in a Y-configuration. Each of the distal ends of the arms may extend from a linear configuration into the expanded Y-configuration, e.g., via a biasing mechanism 332, which may bias the arms to extend once the sheath 212 is retracted. The distal ends of the arms 330A, 330B may extend into the tapered corners of the balloon 174 to facilitate the balloon 174 expansion into the uterine cornu UC and may also help to center the balloon 174 within the uterus UT.

FIG. 46 shows a partial cross-sectional side view of another variation of an expansion mechanism contained within the balloon 174 where one or more supporting arms 342A, 342B may be mechanically actuated to extend, e.g., via, a biasing mechanism, push/pull wires, etc. Moreover, the arms 342A, 342B may be integrated into the design of the cooling probe 340 as an integrated assembly.

FIG. 47 shows a partial cross-sectional side view of another variation where the supporting arms 350A, 350B may also integrate one or more openings 352 for the infusion of the cryoablative fluid. In this example the arms 350A, 350B may be integrated with the cooling probe 340 or separated. In either case, the inclusion of the openings 352 may facilitate the distribution of the fluid into the balloon 174 interior.

FIG. 48 shows yet another variation where the supporting arms 360A, 360B may be incorporated into elongate channels or pockets 362A, 362B defined along the balloon 174 itself. In this and other variations shown, the supporting arm members may optionally integrate the one or more openings for cryoablative fluid delivery and may also be integrated into elongate channels as practicable.

Aside from the balloon itself and the use of balloons for obstructing the os, internal os, and/or external os, as described above, balloons or inflatable liners may also be used to insulate the cryogenic fluid during delivery into the balloon to protect the surrounding tissue structures which are not to be ablated, such as the cervix CV. FIG. 49 shows a partial cross-sectional of one variation where an inflatable balloon 370 may be located along the outside distal surface of sheath 212 for contacting against and directly insulating the cervix CV. The liner or balloon 370 may be filled with a gas or liquid such as air, water, carbon dioxide, etc. to act as an insulator to prevent contact between the delivered cryoablative fluid passing through the shaft 170 and the surrounding cervical tissue. The balloon 370 may be inflated prior to or during an ablation treatment and then deflated once the treatment has been completed to facilitate removal of the device. The size of the balloon 370 may be optionally varied, e.g., by the sheath placement location.

FIG. 50 shows a cross-sectional side view of another variation of an inflatable liner or balloon 380 located along the inside distal surface of sheath 212. In this variation, the balloon 380 may inflate to insulate the cryoablative fluid from the cervical tissue. FIG. 51 shows another variation where expandable foam 390 may be deployed via the outer sheath 212 fix insulating against the cervix CV. FIG. 52 show yet another variation where a beating element 400 may be located along the inner or outer surface of the elongate shaft 170 for heating the surrounding cervical tissue as the cryoablative fluid is delivered during treatment. FIG. 53 shows yet another variation where a ring balloon 410 may be inflated along either the sheath 212 or shaft 170 to either insulate the surrounding cervical tissue or to ensure secure placement of the shaft 170 and/or balloon 174 during treatment.

FIG. 54 shows a cross-sectional side view of yet another variation of a sheath 411 which may be formed from, e.g., urethane having a thin wall of about 0.001 in., which may be doubled over and sealed such that the sheath 411 contains a volume of liquid or gas 413 such as saline, air, etc. The cooling probe assembly having the tubing 201 and balloon 174 in its collapsed state may also be seen. The sheath distal end 415 may optionally incorporate a deformable member such as an elastic or expandable ring 417 contained circumferentially within the distal end 415, as shown in the side view of FIG. 55A. Alternatively, a biased circular member such as a ring 419 comprised of a circularly-formed spring may be contained circumferentially within the distal end 415, as shown in FIG. 55B. With the sheath 411 positioned with its distal end 415 distal to the tubing 201, the ring 417 may configure into a ring having a first diameter which at least partially covers the distal opening of the sheath 411. However, when the tubing 201 is advanced from the sheath 411, the ring 417 may stretch or deform into a second larger diameter as it conforms to the outer surface of the tubing 201. The enlarged ring 417 may accordingly form a stop or detent for preventing the proximal over-withdrawal of the sheath 411 relative to the cervix CV as well as facilitating the positioning of the sheath 411 over the cervix CV to provide insulation during a procedure. As the outer sheath 411 and enlarged ring 417 is positioned proximally along the tubing 201 to secure a position of the ring 417 against cervical tissue, the sheath retraction may accordingly adjust an expanded length of the balloon 174 within the uterus UT.

Moreover, since the positioning of the sheath 411 may also actuate and adjust as position of a mandrel 290 within the one or more lines 307 to selectively obstruct or open a selected number of openings 286 (as illustrated in FIG. 41), the single withdrawal and positioning of the outer sheath 411 may not only provide an adjustable securement of the device relative to the cervical tissue, but it may also correspondingly adjust the balloon expanded length and further control the active length of the delivery line 307 via the mandrel 290 positioning. The sheath retraction and securement may be utilized not only in this variation, but in any of the variations shown and described herein, as practicable.

FIG. 56 shows another variation of a cervical protection balloon 421 may have a length, e.g., 4 to 8 cm, that may also be positioned along the outside surface of the sheath 212 (as shown) or along the inside surface for placement against the cervical tissue. FIG. 57 shows a cross-sectional side view of yet another variation of a dual sheath assembly having an inner sheath 423 and an outer sheath 425 which are longitudinally translatable relative to one another. An annular balloon 427 may be attached to the distal ends of both the inner sheath 423 and outer sheath 425 such that the balloon

427 size and configuration may be altered by the relative movement and positioning of the sheaths 423,425. FIGS. 58A and 58B show detail cross-sectional side views of an example of an arrangement for several seals 429 which may be positioned between each respective sheath 423, 425. Corresponding o-ring seals 431 may be incorporated into the seals 429 to provide for fluid-tight sealing. Also, a fluid line 433 may be passed through one or more seals 429, as shown, to provide for inflation and deflation of the balloon 174 or annular balloon 427.

Another variation is shown in the cross-sectional side view of FIG. 59 which shows another dual sheath design where the annular balloon may be comprised of a confined balloon 441 having an expandable balloon portion 443. The balloon, e.g., urethane, may be contained between each respective sheath 423, 425 while a doubled-over portion may be positioned to extend from between the distal ends of the sheaths 423, 425. As inflation fluid is introduced into the balloon, the portion of the balloon constrained between the sheaths 423, 425 may remain collapsed but the unconstrained expandable balloon portion 443 may expand into an annular shape as shown.

FIG. 60 shows yet another variation where the sheath 445 may be formed to have a reinforcement member 447, e.g., wire, braid, mesh, etc., integrated along its body to provide for added strength and space between the sheath 445 and adjacent tissue. Any of the balloon embodiments described herein may be incorporated, with the sheath 445 as shown.

FIG. 61 shows another variation of a sheath having an annular balloon 449 having positioned along the distal end of the inner sheath 423 while constrained by the distal end of the outer sheath 425. The balloon 449 may be sized according to the relative positioning between the inner and outer sheaths.

FIG. 62A and 62B show partial cross-sectional side views of yet another example of an outer sheath 451 slidably positioned over tubing 201 where the distal end of outer sheath 451 may incorporate an integrated expandable ring 453, e.g., elastomeric, foam, etc. As previously described in a similar embodiment, the expandable ring 453 may have a first diameter which closes upon the distal end of tubing 201 when the outer sheath 451 is advanced distal to the tubing 201. As the outer sheath 451 is retracted relative to tubing 201, the ring 453 may expand to a larger second diameter as it conforms to the outer surface of the tubing 201. The enlarged profile of the outer sheath 451 may thus function as a stop relative to the cervical tissue during a procedure.

FIG. 63 shows a similar variation where the expandable ring 453 may incorporate one or more lubricious surfaces 455 to facilitate the retraction of outer sheath 451, e.g., by peeling the outer layer relative to the inner layer, and the conformance of the ring 453 relative to the tubing 201. FIG. 64 shows a side view of yet another variation where the outer sheath 451 may instead incorporate a discrete ring section 461 having the expandable ring 453 positioned relative to the tubing 201. FIG. 65 shows yet another variation where the distal end of the tubing 201 may define a tapered distal end 463 to facilitate the expansion of the expandable ring 453 when outer sheath 451 is retracted.

In yet another variation of the outer sheath, FIG. 66 shows an embodiment where the outer sheath 465 may have a radially expandable portion 467 formed near or at a distal end of the outer sheath 465. Prior to or during a procedure to secure a position of the outer sheath 465 relative to the cervical tissue, the expandable portion 467 may be utilized rather than an inflatable balloon. The expandable portion 467 may generally comprise one or more lengths of the outer

sheath 465 being reconfigurable along a pivotable or bendable portion such that as the distal end of the outer sheath 465 is retracted relative to the remainder of the sheath 465, the one or more lengths may pivot and reconfigure into its radial configuration.

A linkage 475 (such as wire, rod, string, ribbon, etc.) may be coupled to the distal end of the outer sheath 465 at a first stop 469, as shown in the partial cross-sectional side view of FIG. 67A. A second stop 471 may be positioned proximally of the first stop 469 which limits the proximal withdrawal of the linkage 475 by a predetermined distance. When the linkage 475 engages the first stop 469 and retracts the sheath distal end to radially extend the expandable portion 467, the further retraction of linkage 475 may be stopped by the second stop 471. The outer sheath 465 may define the lumen through which the cooling probe assembly may be advanced without interference from the retraction assembly. Another variation is illustrated in FIG. 67B which shows a similar mechanism but where the second stop 471 may be replaced by a biasing element 473, e.g., spring, positioned proximally of the first stop 469.

Yet another variation is shown in the side views of FIGS. 68A and 68B which illustrate a representation of an exemplary overcenter linkage mechanism 481 which may be incorporated with the retraction mechanism. A linkage 483 and corresponding biasing element 485, e.g., spring, may be coupled to the linkage member 475 attached to the stop 469. As the linkage 475 is retracted to reconfigure the expandable portion 467, the overcenter mechanism 481 may also be retracted and actuated to engage a position of the linkage 475 such that the retraction of the expandable portion 467 may be selectively maintained. The overcenter mechanism 481 may be selectively disengaged to release and reconfigure the expandable portion 467.

FIG. 69 shows a side view of yet another variation where the outer sheath 491 may incorporate one or more distal cam members 493A, 493B. With the outer sheath 491 positioned distally of the tubing 201, the cam members 493A, 493B may be configured into a first collapsed configuration. As the outer sheath 491 is retracted relative to tubing 201, the cam members 493A, 493B may pivot along outer sheath 491 when urged by the outer surface of the tubing 201 and reconfigure into an expanded configuration as indicated. The reconfigured expanded cam members 493A, 493B may then be used as a stop for the outer sheath 491 relative to the cervical tissue.

An example of the reconfigured cam members 493A, 493B used as a stop is illustrated in the exemplary cross-sectional side view of FIG. 70. As indicated, as the outer sheath 491 is retracted and the cam members 493A, 493B reconfigure, the outer sheath 491 may be further retracted until secured against the cervix CV. FIG. 71 shows another example where the outer sheath 501 having the distal tip cam members 503A, 503B may be configured to have a tapered distal end 505 to allow for the further pivoting of the cam members 503A, 503B during sheath retraction.

FIG. 72 shows an exemplary illustration of how the outer sheath 465 may be deployed first and secured into position with, e.g., the expandable portion 467, placed into contact against the cervix CV. The cooling probe assembly and collapsed balloon 174 may then be inserted through the outer sheath 465 at a later time and advanced into the uterus UT for treatment. In this and any of the other variations described herein, as practicable, the outer sheath may be deployed independently of the cooling probe if so desired.

FIG. 73 shows yet another variation where the outer sheath may be configured as a corrugated outer sheath 511

to provide a structure which is strong yet flexible. FIGS. 74 and 75 show additional variations where the outer sheath 513 may comprise an annular balloon 517 located along inner surface of sheath 513. The sheath distal end may define one or more longitudinal slots 515 for selective expansion of the balloon 517. Alternatively, the annular balloon 519 may be located along outer surface of sheath 513, as also previously described.

FIGS. 76A to 76D show yet another variation where the sheath 521 may incorporate an integrated feature to provide further insulation between the cryoablative fluid and the surrounding cervical tissue by creating or forming insulative pockets of air. The variation shown in the cross-sectional end view of FIG. 76A shows a sheath 521 defining a plurality of raised and curved surfaces 523 along the inner surface of the sheath 521. FIG. 76B shows another variation where a plurality of raised and curved surfaces 525 may be formed along the outer surface of the sheath 521. Yet another example is shown in FIG. 76C which shows a sheath 521 formed to have both internal and external raised surfaces 527 while the variation of FIG. 76D shows a variation where the internal sheath surface may have a plurality of raised projections or fingers extending inwardly.

In controlling the ablative treatments described above, the treatment assembly may be integrated into a single cooling system 420, as shown in the exemplary schematic illustration of FIG. 77. The cooling system 420 may be contained entirely within the handle assembly 214 as described above or it may be separated into components, as needed or desired. In either case, the cooling system 420 may generally comprise a microcontroller 422 for monitoring and/or controlling parameters such as cavity temperature, cavity pressure, exhaust pressure, etc. A display 424, e.g., a digital display which may be located along handle assembly 214, may be in communication with the microcontroller 422 for displaying parameters such as cavity pressure, cavity temperature, treatment time, etc. Any errors may also be shown on the display 424 as well. A separate indicator 426, e.g., visual or auditory alarm, may also be in communication with the microcontroller 422 for alerting the user to prompts, errors, etc.

A coolant reservoir 428, e.g., nitrous oxide canister in this example, may be fluidly coupled to the handle 214 and/or elongate shaft 170 via a coolant valve 430 which may be optionally controlled by the microcontroller 422. The coolant reservoir 428 may be in fluid communication with the cooling probe assembly 220 and with the interior of balloon 174. One or more pressure sensors 432 may be in communication with a pressure lumen 434 contained within the cooling probe assembly 220 or elongate shaft 170 and one or more temperature sensors 436 in communication with a thermocouple/thermistor wire 438 also contained within the cooling probe assembly 220 or elongate shaft 170 may be incorporated. The one or more pressure sensors 432 and/or temperature sensors 436 may be in communication with the microcontroller 422 as well. Moreover, the pressure sensors 432 may optionally comprise a sensor positioned within the balloon 174 where the sensor is designed for low temperature measurement. Such a pressure sensor may incorporate a closed or open column of liquid (e.g., ethanol etc.) or gas (e.g., air, carbon dioxide, etc.) which extends through the cooling probe assembly.

The cryoablative fluid contained within the coolant reservoir 428, such as nitrous oxide, may be pumped (or allowed to flow if reservoir 428 is under pressure) via, e.g., a motor-driven valve such as coolant valve 430 to control nitrous oxide inflow rate. The valve 430 may also be used to

maintain a desired amount of back pressure to separate the walls of the uterus. For instance, a relatively low back pressure of e.g., 40 to 60 mm Hg, may be used. Alternatively, a simple but precise exhaust flow restriction might be all that is needed, e.g., such as a fixed, non-adjustable valve, in yet another alternative, vacuum pressure may be used to control the rate at which the exhaust gas is pulled-through, e.g., a nitrous oxide deactivation filter.

The rate at which the cryoablative fluid, such as the nitrous oxide, is delivered may be controlled by the temperature measured within the balloon 174 and/or uterine cavity. The target temperature range may range, e.g., between -65 and -80 degrees C. By limiting the temperature measured within the balloon 174 to a value which is lower than the boiling point of nitrous oxide, about -88.5 degrees C., the chance of liquid nitrous oxide build-up in the balloon 174 may be greatly reduced to prevent any excessive intra-uterine pressures if the exhaust tube is blocked.

In the event that excessive pressure is measured within the balloon 174 or the pressure differential between two sensors is too large, the system may be programmed to automatically stop the flow of the cryoablative fluid. A separate shut-off valve may be used in-place of the coolant valve 430. Furthermore, if electrical power is interrupted to the system, the separate shut-off valve may automatically be actuated. In addition, the indicator 426 may signal to the user that excessive pressures were reached and the system shut-down.

The inside diameter of the delivery line may also be sized to deliver cryoablative fluid up to but not exceeding, e.g., a maximum anticipated rate for a large, well-perfuse uterus. By limiting the rate of cryoablative fluid infusion and sizing the exhaust tube appropriately, the system may be able to evacuate the expanded gas even in the event of a catastrophic failure of the delivery line.

Additionally, an exhaust lumen 440 in communication with the elongate probe 170 and having a back pressure valve 444 may also include a pressure sensor 442 where one or both of the back pressure sensor 442 and/or valve 444 may also be in communication with the microcontroller 422. While the microcontroller 422 may be used to control the pressure of the introduced cryoablative fluid, the pressure of the cryoablative fluid within the balloon 174 interior may also be controlled automatically by the microcontroller 422 adjusting the back pressure valve 444 or by manually adjusting the back pressure valve 444. In the event that the microcontroller 422 is used to control the back pressure via valve 444, the microcontroller 422 may be configured or otherwise programmed to adjust the valve 444 based on feedback from other sensors, such as the measured parameters from the one or more pressure sensors 432 and/or temperature sensors 436 to create a closed feedback loop system.

The exhaust lumen 440 may be fluidly connected, e.g., to a reservoir 446 for collecting or deactivating the exhausted cryoablative fluid. The reservoir 446 may optionally incorporate a filter into the handle 214 or become integrated into a reusable console. Alternatively, the exhausted cryoablative fluid may be simply collected in a reservoir 446 or exhausted into atmosphere.

Generally, redundant pressure lines and sensors, such as pressure lumen 434, that terminate in the balloon 174 may correspond to sensors located in the handle 214 to make comparison measurements. The pressure lines may be filled, with a fluid such as ethanol to prevent freezing during a procedure. Alternatively, a gas such as air may be used in the pressure lines but may utilize temperature compensation.

As at least one thermocouple may be located within the balloon 174 and used to measure temperature during the procedure, additional thermocouples may be optionally included at other locations internal or external to the balloon 174 to provide for additional temperature measurements. For example, a thermocouple may be optionally located on the distal portion of the sheath 212 to monitor temperature within the cervix CV.

After completion of the procedure, all unused cryoablative fluid still contained in the reservoir 428 or within the system may be automatically or manually vented, e.g., to the deactivation filter or collection reservoir 446.

The system 420 may optionally further incorporate an emergency shut-off system which may be actuated in the event that electrical power is lost, if a user manually activates the shut-off system, or in the event that the micro-controller 422 detects a high-pressure within the system 420. One example of the emergency shut-off system may incorporate an emergency shut-off valve which may include valve 430 or which may alternatively incorporate another valve separate from valve 430. Moreover, in detecting the pressure within the system 420, a redundant pressure sensor may also be utilized along with the one or more pressure sensors 432 either at the same location or at a different location along the system 420.

In any of the examples described herein, the system may employ a thermally conductive fluid having a thermal conductivity greater than that of saline. This thermal conductivity may help to ensure that the fluid within the body cavity or lumen is at the same temperature throughout even without agitation or lavage. Such a fluid may be used with the fluid lavage and/or the fluid infusion followed by application of a cryoprobe. The improved thermal conductivity may be achieved via a variety of different options including, but not limited to, choice of a thermally conductive fluid or gel, addition of thermally conductive compounds to the fluid or gel (e.g., metals or metal ions, etc.) and/or agitation of the fluid within the cavity to help achieve equilibration of the temperature. Additionally, the fluid may be infused as a fluid or gel until a set pressure is achieved. The cryoprobe may then be introduced into the body cavity/lumen and heat may be withdrawn from the fluid/gel. Prior to or in concert with the achievement of a cryotherapeutic (ablative or non-ablative) temperature, the fluid or may form a gel or solid. This may be utilized such that fluid or gel within the cavity may be trapped within the target lumen or body cavity with its change in viscosity or state thereby preventing leakage of the fluid or gel and unwanted exposure of adjacent tissues to the cryotherapeutic effect. Due to the higher thermal conductivity or the gelled or frozen fluid or gel, the continued removal of heat from the gelled or frozen mass may be rapidly and uniformly distributed throughout the body cavity or lumen. The solution may also be partially frozen or gelled and then agitated or recirculated to ensure even greater distribution of the cryotherapeutic effect.

Furthermore, the fluid or gel may be made thermally conductive by the addition of a biocompatible metal or metallic ion. Any metal or conductive material may be used for this purpose, e.g., silver, gold, platinum, titanium, stainless steel, or other metals which are biocompatible. Alternatively the thermally conductive fluid may be used to transmit the thermal energy to tissues in order to provide thermal ablation as opposed to the extraction of energy with cryoablation. In either embodiment, with sufficient thermal conductivity the fluid may act as an extension of the ablative energy source and provide a custom ablation tip for the application of or removal of energy from any body tissues,

body cavities, or body lumens. Another benefit is consistency of treatment since cryoablation may require use of ultrasound in the setting of uterine ablation. Any of the devices herein may allow for the use of temperature tracking or simple timed treatment in order to automate the ablation with or without ultrasound monitoring). For example, application of -80 C for 3 minutes has been shown to provide the correct depth of ablation for many uterine cavities. The devices herein may allow for the tracking of temperature such that once a desired temperature is reached (e.g., -60 C) to timer may be triggered, which automatically discontinues therapy and warms the cavity based on time alone. This may be used in the setting, of a fixed volume infusion (e.g., 10 to 15 cc of thermally conductive fluid/gel for all patients) or in the setting of infusion of a fluid/gel to a set pressure (with variable volumes). This timed ablation may also be used in concert with any of the device herein to allow for elimination of the burdensome requirement for ultrasound tracking of the cryogenically treated regions.

Alternatively, this thermally conducting fluid (which may optionally include solid particles of metal) may be infused into a balloon which conforms to the uterus, esophagus or other body cavity or lumen at relatively low pressures (e.g., less than 150 mmHg), as also described above. The thermally conducting material may alternatively be comprised entirely of a solid (e.g., copper spheres or a copper chain) within the conforming balloon wherein the thermally conductive solid and/or fluid may be reversibly delivered into the conforming balloon under low pressure after which a cryoprobe, cryogenic liquid and/or cryogenic gas may be delivered into the balloon and activated to ablate the entirety of the uterus UT at once. The cryogen source may also be positioned within the balloon to obtain maximum cryoablation within the body of uterus with less ablative effect proximally and in the cornua. Vaseline, oils or other thermally resistive materials may also be used in conjunction with this or other modalities in order to protect certain areas of the uterus, cervix and vagina.

In creating the optimal thermally conductive fluid and/or gel, any conductive material may be added to the fluid or gel, including, e.g., gold, silver, platinum, steel, iron, titanium, copper or any other conductive metal, ion, or molecule. If a metal is used as a dopant to increase the thermal conductivity, the added metal may take any shape or form including spheres, rods, powder, nanofibers, nanotubes, atmospheres, thin filaments or any other shape that may be suspended in a solution or gel. The fluid or gel may itself also be thermally conductive and may be infused and then removed or may be left in the cavity and allowed to flow naturally from the uterus as with normal menstruation. The thermally conductive polymer may also be biocompatible, as well, but this may not be necessary if the fluid/gel is extracted immediately following the procedure.

Despite the potential for toxicity, ethanol may be well suited for a liquid lavage in that it resists freezing down to -110 C and is, other than dose dependent toxicity, biocompatible. Solutions of 75% to 99.9% ethanol concentrations may be used to good effect and have been demonstrated to show that a freeze layer develops very rapidly inhibiting further ethanol absorption. An ethanol copper composition may also be used since ethanol resists freezing whereas aqueous fluid freeze and expand thereby moving the metal particle out of direct contact with the tissue.

While illustrative examples are described above, it will be apparent to one skilled in the art that various changes and modifications may be made therein. Moreover, various apparatus or procedures described above are also intended to

be utilized in combination with one another, as practicable. The appended claims are intended to cover all such changes and modifications that fall within the true spirit and scope of the invention.

What is claimed is:

1. A tissue treatment system, comprising:
an elongate lumen having a distal tip and a length;
at least one infusion lumen positioned through or along the elongate lumen;
at least one delivery lumen in fluid communication with the infusion lumen, wherein the delivery lumen defines one or more openings therealong;
a liner defining an interior in which the elongate lumen is positionable; and
a sheath translatable relative to the elongate lumen, wherein translation of the sheath selectively controls a number of the one or more openings which remain unobstructed and also correspondingly adjusts an expanded length of the liner according to the number of one or more openings which are unobstructed.
2. The system of claim 1 further comprising a reservoir having an ablative agent in fluid communication with the at least one delivery lumen, wherein introduction of the ablative agent within the delivery lumen passes the ablative agent through the unobstructed one or more openings and into contact against an interior surface of the liner.
3. The system of claim 2 wherein the ablative agent comprises a cryoablative or hyperthermic agent.
4. The system of claim 3 wherein the cryoablative agent comprises nitrous oxide.
5. The system of claim 1 further comprising an exhaust lumen in fluid communication with the interior of the liner.
6. The system of claim 1 wherein the infusion lumen and delivery lumen form separate lines in fluid communication through the interior of the liner.
7. The system of claim 1 wherein the elongate lumen is configured to bend within a single plane via one or more slots defined along the elongate lumen.
8. The system of claim 1 wherein the elongate lumen defines an active treatment portion near or at the distal tip.
9. The system of claim 8 wherein the active treatment portion ranges from 2 to 14 cm in length.
10. The system of claim 1 wherein a portion of the liner is attached to the elongate lumen proximal of the distal tip.
11. The system of claim 1 wherein the liner comprises at least two tapered portions configured to contact a corresponding uterine cornu.
12. The system of claim 1 further comprising a mandrel slidably positioned within or along the at least one delivery lumen, wherein a distal or proximal translation of the mandrel relative to the delivery lumen selectively controls the number of unobstructed openings along the delivery lumen.
13. The system of claim 12 wherein the translation of the mandrel is actuated via the translation of the sheath.

14. The system of claim 1 further comprising a stopping mechanism positioned along the sheath.

15. The system of claim 14 wherein a position of the stopping mechanism relative to the elongate lumen correspondingly adjusts a length of the expanded length of the liner.

16. A tissue treatment system, comprising:
an elongate lumen;

at least one infusion lumen positioned through or along the elongate lumen;

at least one delivery lumen in fluid communication with the infusion lumen, where the delivery lumen defines one or more openings therealong;

a liner defining a volume into which the elongate lumen is insertable, wherein the liner when expanded is configured to conform to a tissue surface;

a sheath translatable relative to the elongate lumen, wherein translation of the sheath selectively controls a number of the one or more openings which remain unobstructed and also correspondingly adjusts an expanded length of the liner according to the number of one or more openings which are unobstructed; and

a controller configured to control infusion of an ablative agent into the volume of the liner.

17. The system of claim 16 further comprising a reservoir having an ablative agent in fluid communication with the at least one delivery lumen, wherein introduction of the ablative agent within the delivery lumen passes the ablative agent through the unobstructed one or more openings and into contact against an interior surface of the liner.

18. The system of claim 16 wherein the ablative agent comprises nitrous oxide.

19. The system of claim 16 wherein the controller is configured to control a delivery rate of the ablative agent into the volume of the liner.

20. The system of claim 19 wherein the controller is configured to control the delivery rate in response to a sensed temperature and/or pressure parameter.

21. The system of claim 16 further comprising one or more temperature sensors in communication with the volume of the liner.

22. The system of claim 16 further comprising one or more pressure sensors in communication with the volume of the liner.

23. The system of claim 16 further comprising a valve in communication with an exhaust lumen in communication with the volume of the liner.

24. The system of claim 23 wherein the valve is adjustable via the controller.

* * * * *

| | | | |
|----------------|--|---------|------------|
| 专利名称(译) | 用于低温处理体腔或腔的方法和设备 | | |
| 公开(公告)号 | US10213335 | 公开(公告)日 | 2019-02-26 |
| 申请号 | US15/065684 | 申请日 | 2016-03-09 |
| [标]申请(专利权)人(译) | 查内尔麦德系统公司 | | |
| 申请(专利权)人(译) | CHANNEL MedSystems公司, INC. | | |
| 当前申请(专利权)人(译) | CHANNEL MedSystems公司, INC. | | |
| [标]发明人 | BURNETT DANIEL R NEIL BRIAN M MALECKI WILLIAM W KOCH KATHLEEN M LEE GREGORY J | | |
| 发明人 | BURNETT, DANIEL R. NEIL, BRIAN M. MALECKI, WILLIAM W. KOCH, KATHLEEN M. LEE, GREGORY J. | | |
| IPC分类号 | A61B18/02 A61F7/12 A61B18/04 A61B17/12 A61B5/01 A61B5/00 A61B17/00 A61B18/00 | | |
| CPC分类号 | A61F7/123 A61B5/4836 A61B17/12022 A61B18/02 A61B18/0218 A61B18/04 A61B5/01 A61B2018/046 A61B5/6853 A61B2017/00539 A61B2018/00011 A61B2018/0022 A61B2018/00041 A61B2018/00488 A61B2018/00553 A61B2018/00559 A61B2018/00577 A61B2018/00791 A61B2018/00863 A61B2018/00982 A61B2018/0212 A61B2018/0262 | | |
| 优先权 | 61/462328 2011-02-01 US 61/571123 2011-06-22 US | | |
| 其他公开文献 | US20160183999A1 | | |
| 外部链接 | Espacenet | | |

摘要(译)

描述了用于治疗体腔或腔的方法和装置，其中加热的流体和/或气体可以通过导管引入并进入包含在一个或多个可膨胀/可膨胀构件之间的身体内的治疗区域。导管还可以具有可选的压力和温度传感元件，其可以允许控制治疗区域内的压力和温度，并且还防止压力超过可膨胀/可膨胀构件的压力，从而包含这些可膨胀/可膨胀/之间的治疗区域。可扩展成员。任性地，然后可以使用冷却的，室温或温热的流体（例如水）来快速终止治疗期。

