

US008956350B2

(12) **United States Patent**  
**Buyse et al.**

(10) **Patent No.:** **US 8,956,350 B2**  
(45) **Date of Patent:** **\*Feb. 17, 2015**

(54) **THERMAL FEEDBACK SYSTEMS AND METHODS OF USING THE SAME**

(71) Applicant: **Covidien LP**, Mansfield, MA (US)

(72) Inventors: **Steven P. Buyse**, Niwot, CO (US);  
**Casey M. Ladtkow**, Erie, CO (US);  
**Brandon Gay**, Superior, CO (US)

(73) Assignee: **Covidien LP**, Mansfield, MA (US)

(\* ) Notice: Subject to any disclaimer, the term of this patent is extended or adjusted under 35 U.S.C. 154(b) by 0 days.

This patent is subject to a terminal disclaimer.

(21) Appl. No.: **14/066,050**

(22) Filed: **Oct. 29, 2013**

(65) **Prior Publication Data**

US 2014/0058384 A1 Feb. 27, 2014

**Related U.S. Application Data**

(60) Continuation of application No. 13/539,725, filed on Jul. 2, 2012, now Pat. No. 8,568,402, which is a division of application No. 12/023,606, filed on Jan. 31, 2008, now Pat. No. 8,211,099.

(60) Provisional application No. 60/887,537, filed on Jan. 31, 2007.

(51) **Int. Cl.**  
**A61B 18/18** (2006.01)  
**A61B 5/00** (2006.01)

(Continued)

(52) **U.S. Cl.**  
CPC ..... **A61B 5/4836** (2013.01); **A61B 18/1477** (2013.01); **A61B 5/015** (2013.01);

(Continued)

(58) **Field of Classification Search**

USPC ..... 606/32-35  
See application file for complete search history.

(56) **References Cited**

U.S. PATENT DOCUMENTS

2,031,682 A 2/1936 Wappler et al.  
D223,367 S 4/1972 Kountz

(Continued)

FOREIGN PATENT DOCUMENTS

CN 1103807 A 6/1995  
DE 390937 C 3/1924

(Continued)

OTHER PUBLICATIONS

Michael Choti, "Abdominoperineal Resection with the LigaSure.TM. Vessel Sealing System and LigaSure.TM. Atlas 20 cm Open Instrument" Innovations That Work, Jun. 2003.

(Continued)

*Primary Examiner* — Linda Dvorak  
*Assistant Examiner* — Amanda Scott

(57) **ABSTRACT**

A system for providing feedback during an electrosurgical procedure on a target tissue is provided. The system includes an electrosurgical energy source; an electrode probe assembly connected to the electrosurgical energy source, wherein the electrode probe assembly includes at least one electrode assembly having a needle configured to deliver electrosurgical energy to the target tissue; at least one thermal feedback assembly connected to the electrosurgical energy source, wherein each thermal feedback assembly includes at least one temperature sensor assembly; and a hub configured to selectively support the electrode probe assembly and each thermal feedback assembly such that the needle of the electrode probe assembly and each temperature sensor assembly of each thermal feedback assembly are proximate one another when disposed proximate the target tissue.

**19 Claims, 6 Drawing Sheets**

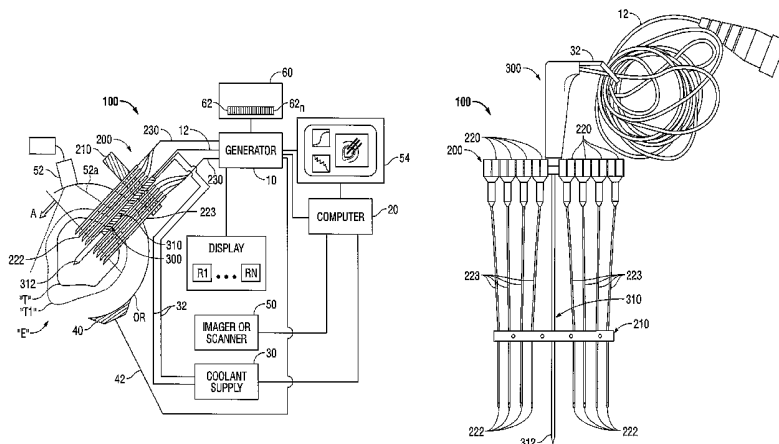

(51)	<b>Int. Cl.</b>						
	<i>A61B 18/14</i>	(2006.01)	5,496,312	A	3/1996	Klicek	
	<i>A61B 5/01</i>	(2006.01)	5,500,012	A	3/1996	Brucker et al.	
	<i>A61B 18/12</i>	(2006.01)	5,520,684	A	5/1996	Imran	
	<i>A61B 18/00</i>	(2006.01)	5,536,267	A	7/1996	Edwards et al.	
	<i>A61B 19/00</i>	(2006.01)	5,571,147	A	11/1996	Sluijter et al.	
(52)	<b>U.S. Cl.</b>		5,588,432	A	12/1996	Crowley	
	CPC	<i>A61B 5/743</i> (2013.01); <i>A61B 18/1206</i>	5,599,345	A	2/1997	Edwards et al.	
		(2013.01); <i>A61B 18/18</i> (2013.01); <i>A61B</i>	5,643,197	A	7/1997	Brucker et al.	
		<i>2018/00702</i> (2013.01); <i>A61B 2018/00791</i>	5,647,871	A	7/1997	Levine et al.	
		(2013.01); <i>A61B 2018/00797</i> (2013.01); <i>A61B</i>	5,662,111	A	9/1997	Cosman	
		<i>2018/00815</i> (2013.01); <i>A61B 2018/00821</i>	5,683,384	A	11/1997	Gough et al.	
		(2013.01); <i>A61B 2019/5236</i> (2013.01); <i>A61B</i>	5,688,267	A	11/1997	Panescu et al.	
		<i>2019/5238</i> (2013.01); <i>A61B 2019/524</i>	5,735,847	A	4/1998	Gough et al.	
		(2013.01); <i>A61B 2019/5276</i> (2013.01)	5,775,338	A	7/1998	Hastings	
	USPC	606/34; 606/41	5,792,146	A	8/1998	Cosman	
			5,848,967	A	12/1998	Cosman	
			5,849,011	A	12/1998	Jones et al.	
			5,868,740	A	2/1999	LeVeen et al.	
			5,897,552	A *	4/1999	Edwards et al.	606/31
			5,921,982	A	7/1999	Lesh et al.	
			5,943,719	A	8/1999	Feldman et al.	
			5,951,546	A	9/1999	Lorentzen	
			6,001,093	A	12/1999	Swanson et al.	
			6,006,126	A	12/1999	Cosman	
			6,053,912	A	4/2000	Panescu et al.	
			D424,693	S	5/2000	Pruter	
			D424,694	S	5/2000	Tetzlaff et al.	
			D425,201	S	5/2000	Tetzlaff et al.	
			6,059,780	A	5/2000	Gough et al.	
			6,061,551	A	5/2000	Sorrells et al.	
			6,071,281	A	6/2000	Burnside et al.	
			6,074,389	A	6/2000	Levine et al.	
			6,080,149	A	6/2000	Huang et al.	
			6,080,150	A	6/2000	Gough	
			6,106,524	A	8/2000	Eggers et al.	
			6,113,591	A *	9/2000	Wayne et al.	606/34
			6,132,426	A	10/2000	Kroll	
			6,146,380	A	11/2000	Racz et al.	
			6,161,048	A	12/2000	Sluijter et al.	
			6,162,216	A	12/2000	Guziak et al.	
			6,203,541	B1	3/2001	Keppel	
			6,241,725	B1	6/2001	Cosman	
			6,246,912	B1	6/2001	Sluijter et al.	
			6,277,116	B1 *	8/2001	Utely et al.	606/42
			6,287,305	B1	9/2001	Heim et al.	
			D449,886	S	10/2001	Tetzlaff et al.	
			6,306,132	B1	10/2001	Moorman et al.	
			6,337,998	B1	1/2002	Behl et al.	
			D457,958	S	5/2002	Dycus et al.	
			D457,959	S	5/2002	Tetzlaff et al.	
			6,405,733	B1	6/2002	Fogarty et al.	
			6,432,070	B1	8/2002	Talish et al.	
			6,478,793	B1	11/2002	Cosman et al.	
			6,500,172	B1	12/2002	Panescu et al.	
			6,506,189	B1	1/2003	Rittman, III et al.	
			6,530,922	B2	3/2003	Cosman et al.	
			6,537,272	B2	3/2003	Christopherson et al.	
			6,551,311	B2	4/2003	Lee et al.	
			6,562,033	B2	5/2003	Shah et al.	
			6,569,159	B1	5/2003	Edwards et al.	
			6,575,969	B1 *	6/2003	Rittman et al.	606/41
			6,587,731	B1 *	7/2003	Ingle et al.	607/101
			6,605,085	B1	8/2003	Edwards	
			6,613,047	B2	9/2003	Edwards	
			6,622,731	B2	9/2003	Daniel et al.	
			6,673,070	B2	1/2004	Edwards et al.	
			D487,039	S	2/2004	Webster et al.	
			6,685,729	B2	2/2004	Gonzalez	
			6,699,243	B2	3/2004	West et al.	
			6,783,523	B2	8/2004	Qin et al.	
			6,786,905	B2	9/2004	Swanson et al.	
			D496,997	S	10/2004	Dycus et al.	
			6,807,444	B2	10/2004	Tu et al.	
			D499,181	S	11/2004	Dycus et al.	
			6,918,907	B2	7/2005	Kelly et al.	
			7,008,421	B2	3/2006	Daniel et al.	
			D525,361	S	7/2006	Hushka	
			D531,311	S	10/2006	Guerra et al.	
			7,131,970	B2	11/2006	Moses et al.	

(56) **References Cited**

U.S. PATENT DOCUMENTS

4,074,718	A	2/1978	Morrison, Jr.
4,075,497	A	2/1978	Kraus
4,215,275	A	7/1980	Wickersheim
D263,020	S	2/1982	Rau, III
D266,842	S	11/1982	Villers et al.
4,375,220	A	3/1983	Matvias
4,411,266	A	10/1983	Cosman
4,448,547	A	5/1984	Wickersheim
D278,306	S	4/1985	McIntosh
4,560,286	A	12/1985	Wickersheim
4,565,200	A	1/1986	Cosman
4,576,177	A	3/1986	Webster, Jr.
4,608,977	A	9/1986	Brown
4,662,383	A	5/1987	Sogawa et al.
4,739,759	A	4/1988	Rexroth et al.
D295,893	S	5/1988	Sharkany et al.
D295,894	S	5/1988	Sharkany et al.
4,752,141	A	6/1988	Sun et al.
4,832,024	A	5/1989	Boussignac et al.
4,880,719	A	11/1989	Murofushi et al.
4,883,354	A	11/1989	Sun et al.
4,961,435	A	10/1990	Kitagawa et al.
4,966,597	A	10/1990	Cosman
4,988,212	A	1/1991	Sun et al.
4,993,430	A	2/1991	Shimoyama et al.
5,029,588	A	7/1991	Yock et al.
5,103,804	A	4/1992	Abele et al.
5,225,741	A	7/1993	Auld, Jr. et al.
5,230,623	A	7/1993	Guthrie et al.
5,233,515	A	8/1993	Cosman
5,246,438	A	9/1993	Langberg
5,267,994	A	12/1993	Gentelia et al.
5,281,213	A	1/1994	Milder et al.
5,323,778	A	6/1994	Kandarpa et al.
5,330,470	A	7/1994	Hagen
5,330,518	A	7/1994	Neilson et al.
5,334,193	A	8/1994	Nardella
5,342,357	A	8/1994	Nardella
5,348,554	A	9/1994	Imran et al.
5,370,675	A	12/1994	Edwards et al.
D354,218	S	1/1995	Van de Peer
5,383,876	A	1/1995	Nardella
5,383,917	A	1/1995	Desai et al.
5,385,148	A	1/1995	Lesh et al.
5,403,311	A *	4/1995	Abele et al.
5,409,000	A	4/1995	Imran
5,409,006	A	4/1995	Buchholtz et al.
5,417,686	A	5/1995	Peterson et al.
5,433,739	A	7/1995	Sluijter et al.
5,437,662	A	8/1995	Nardella
5,458,597	A	10/1995	Edwards et al.
5,462,521	A	10/1995	Brucker et al.
5,472,441	A	12/1995	Edwards et al.
5,490,850	A	2/1996	Ellman et al.

(56)

## References Cited

## U.S. PATENT DOCUMENTS

7,137,980 B2 11/2006 Buysse et al.  
D533,942 S 12/2006 Kerr et al.  
7,150,749 B2 12/2006 Dycus et al.  
D535,027 S 1/2007 James et al.  
7,156,842 B2 1/2007 Sartor et al.  
7,156,846 B2 1/2007 Dycus et al.  
7,169,146 B2 1/2007 Truckai et al.  
7,179,255 B2 2/2007 Lettice et al.  
7,186,222 B1 3/2007 Callister et al.  
D541,418 S 4/2007 Schechter et al.  
7,207,989 B2 4/2007 Pike, Jr. et al.  
D541,938 S 5/2007 Kerr et al.  
7,218,958 B2 5/2007 Rashidi  
7,220,260 B2 5/2007 Fleming et al.  
7,235,070 B2 6/2007 Vanney  
7,235,073 B2 6/2007 Levine et al.  
7,238,184 B2 7/2007 Megerman et al.  
7,252,667 B2 8/2007 Moses et al.  
7,264,619 B2 9/2007 Venturelli  
7,278,991 B2 10/2007 Morris et al.  
7,282,049 B2 10/2007 Orszulak et al.  
7,294,127 B2 11/2007 Leung et al.  
7,294,143 B2 11/2007 Francischelli  
7,302,285 B2 11/2007 Fuimaono et al.  
7,303,558 B2 12/2007 Swanson  
7,331,947 B2 2/2008 McGuckin, Jr. et al.  
RE40,156 E 3/2008 Sharps et al.  
D564,662 S 3/2008 Moses et al.  
7,341,586 B2 3/2008 Daniel et al.  
7,344,533 B2 3/2008 Pearson et al.  
RE40,279 E 4/2008 Sluijter et al.  
7,364,578 B2 4/2008 Francischelli et al.  
7,364,579 B2 4/2008 Mulier et al.  
7,367,974 B2 5/2008 Haemmerich et al.  
7,367,975 B2 5/2008 Malecki et al.  
7,387,625 B2 6/2008 Hovda et al.  
D576,932 S 9/2008 Strehler  
7,419,486 B2 9/2008 Kampa  
7,419,487 B2 9/2008 Johnson et al.  
7,419,488 B2 9/2008 Ciarrocca et al.  
7,419,489 B2 9/2008 Vanney et al.  
7,422,586 B2 9/2008 Morris et al.  
7,422,587 B2 9/2008 Bek et al.  
D594,736 S 6/2009 Esjunin  
D594,737 S 6/2009 Kelly et al.  
7,553,309 B2 6/2009 Buysse et al.  
D606,203 S 12/2009 Husheer et al.  
D613,412 S 4/2010 DeCarlo  
7,763,018 B2 7/2010 DeCarlo et al.  
7,776,035 B2 8/2010 Rick et al.  
7,811,283 B2 10/2010 Moses et al.  
7,879,031 B2 2/2011 Peterson  
7,885,625 B2 2/2011 Muhammad et al.  
D634,010 S 3/2011 DeCarlo  
8,034,052 B2 10/2011 Podhajsky  
8,182,477 B2 5/2012 Orszulak et al.  
8,211,099 B2 7/2012 Buysse et al.  
D681,810 S 5/2013 Decarlo  
8,568,402 B2 10/2013 Buysse et al.  
2002/0111615 A1\* 8/2002 Cosman et al. .... 606/41  
2002/0156472 A1 10/2002 Lee et al.  
2003/0208193 A1\* 11/2003 Van Wyk ..... 606/34  
2005/0096681 A1 5/2005 Desinger et al.  
2005/0155743 A1 7/2005 Getz et al.  
2005/0192564 A1 9/2005 Cosman et al.  
2006/0079886 A1\* 4/2006 Orszulak et al. .... 606/41  
2006/0079887 A1\* 4/2006 Buysse et al. .... 606/41  
2007/0066971 A1 3/2007 Podhajsky  
2007/0073282 A1 3/2007 McGaffigan et al.  
2007/0078453 A1 4/2007 Johnson et al.  
2007/0078454 A1 4/2007 McPherson  
2007/0100405 A1 5/2007 Thompson et al.  
2008/0004615 A1 1/2008 Woloszko et al.  
2008/0015664 A1 1/2008 Podhajsky  
2008/0125775 A1 5/2008 Morris

2008/0147056 A1 6/2008 van der Weide et al.  
2008/0183165 A1 7/2008 Buysse et al.  
2011/0009804 A1 1/2011 Behnke  
2011/0208177 A1 8/2011 Brannan  
2011/0301589 A1 12/2011 Podhajsky et al.  
2011/0301590 A1 12/2011 Podhajsky et al.  
2011/0306969 A1 12/2011 Coe et al.

## FOREIGN PATENT DOCUMENTS

DE 1099658 B 2/1961  
DE 1139927 B 11/1962  
DE 1149832 B 6/1963  
DE 1439302 A1 1/1969  
DE 2439587 A1 2/1975  
DE 2455174 A1 5/1975  
DE 2407559 A1 8/1975  
DE 2415263 A1 10/1975  
DE 2429021 A1 1/1976  
DE 2460481 A1 6/1976  
DE 2602517 A1 7/1976  
DE 2504280 A1 8/1976  
DE 2627679 A1 1/1977  
DE 2540968 A1 3/1977  
DE 2820908 A1 11/1978  
DE 2803275 A1 8/1979  
DE 2823291 A1 11/1979  
DE 2946728 A1 5/1981  
DE 3143421 A1 5/1982  
DE 3045996 A1 7/1982  
DE 3120102 A1 12/1982  
DE 3510586 A1 10/1986  
DE 3604823 A1 8/1987  
DE 8712328 U1 2/1988  
DE 3711511 C1 6/1988  
DE 3904558 A1 8/1990  
DE 3942998 A1 7/1991  
DE 4238263 A1 5/1993  
DE 04303882 C2 2/1995  
DE 4339049 A1 5/1995  
DE 29616210 U1 11/1996  
DE 19608716 C1 4/1997  
DE 19751106 A1 5/1998  
DE 19717411 A1 11/1998  
DE 19751108 A1 5/1999  
DE 19801173 C1 7/1999  
DE 19848540 A1 5/2000  
DE 10224154 A1 12/2003  
DE 10310765 A1 9/2004  
DE 10328514 B3 3/2005  
DE 102004022206 A1 12/2005  
DE 202005015147 U1 2/2006  
DE 102009015699 A1 5/2010  
EP 171967 A2 2/1986  
EP 0 246 350 A1 11/1987  
EP 310431 A2 4/1989  
EP 0 521 264 A2 1/1993  
EP 0 556 705 A1 8/1993  
EP 0 558 429 A1 9/1993  
EP 608609 A2 8/1994  
EP 0 648 515 A1 4/1995  
EP 0 836 868 A2 4/1998  
EP 0 882 955 A1 12/1998  
EP 1 070 518 A2 1/2001  
EP 1 159 926 A2 12/2001  
EP 1462065 A2 9/2004  
EP 1465037 A2 10/2004  
EP 1 645 234 A1 4/2006  
EP 1656900 A2 5/2006  
FR 179 607 11/1906  
FR 1 275 415 A 11/1961  
FR 1 347 865 A 1/1964  
FR 2 235 669 A1 1/1975  
FR 2 276 027 A1 1/1976  
FR 2 313 708 A1 12/1976  
FR 2 502 935 A1 10/1982  
FR 2 517 953 A1 6/1983  
FR 2 573 301 A1 5/1986  
FR 2 862 813 A1 5/2005

(56)

## References Cited

## FOREIGN PATENT DOCUMENTS

FR	2 864 439 A1	7/2005
JP	5-5106	1/1993
JP	05-40112	2/1993
JP	06343644 A	12/1994
JP	07265328 A	10/1995
JP	08056955 A	3/1996
JP	08252263 A	10/1996
JP	09000492 A	1/1997
JP	09010223 A	1/1997
JP	11244298 A	9/1999
JP	2000342599 A	12/2000
JP	2000350732 A	12/2000
JP	2001003776 A	1/2001
JP	2001008944 A	1/2001
JP	2001029356 A	2/2001
JP	2001037775 A	2/2001
JP	2001128990 A	5/2001
JP	2001231870 A	8/2001
JP	2008142467 A	6/2008
KR	20070093068	9/2007
KR	20100014406	2/2010
KR	20120055063	5/2012
SU	166452	11/1964
SU	401367 A1	10/1973
SU	727201 A2	4/1980
WO	93/24066 A1	12/1993
WO	94/28809 A1	12/1994
WO	96/04860 A1	2/1996
WO	96/18349 A2	6/1996
WO	96/29946 A1	10/1996
WO	96/34571 A1	11/1996
WO	96/39914 A1	12/1996
WO	97/06739 A2	2/1997
WO	97/06740 A2	2/1997
WO	97/06855 A2	2/1997
WO	97/17029 A1	5/1997
WO	9901074 A1	1/1999
WO	9904710 A1	2/1999
WO	9922657 A1	5/1999
WO	00/36985 A2	6/2000
WO	WO00/36985	6/2000
WO	0067846 A1	11/2000
WO	0100114 A1	1/2001
WO	2004/045436 A1	6/2004
WO	2005009528 A1	2/2005
WO	2010/035831 A1	4/2010
WO	WO2010/035831	4/2010

## OTHER PUBLICATIONS

- Muller et al., "Extended Left Hemicolectomy Using the LigaSure.TM. Vessel Sealing System" *Innovations That Work*, L.J, Sep. 1999.
- Murakami, R. et al., (1995). "Treatment of Hepatocellular Carcinoma: Value of Percutaneous Microwave Coagulation," *American Journal of Radiology (AJR)* 164:1159-1164.
- Ni Wei et al., "A Signal Processing Method for the Coriolis Mass Flowmeter Based on a Normalized . . ." *Journal of Applied Sciences*. cndot.Yingyong Kexue Xuebao, Shangha CN, vol. 23, No. 2:(Mar. 2005); pp. 160-184.
- Ogden, "Goertzel Alternative to the Fourier Transform" Jun. 1993 pp. 485-487 *Electronics World*; Reed Business Publishing, Sutton, Surrey, BG, vol. 99, No. 9, 1687.
- Olsson M.D. et al., "Radical Cystectomy in Females" *Current Surgical Techniques in Urology*, vol. 14, Issue 3, 2001.
- Organ, L W., "Electrophysiologic Principles of Radiofrequency Lesion Making" *Appl. Neurophysiol*, vol. 39: pp. 69-76 (1976/77).
- P.R. Stauffer et al., "Interstitial Heating Technologies", *Thermoradiotherapy and Thermochemotherapy (1995) vol. I, Biology, Physiology, Physics*, pp. 279-320.
- Palazzo et al., "Randomized clinical trial of LigaSure.TM. versus open haemorrhoidectomy" *British Journal of Surgery* 2002,89,154-157 "Innovations in Electrosurgery" Sales/Product Literature, Dec. 31, 2000.
- Paul G. Horgan, "A Novel Technique for Parenchymal Division During Hepatectomy" *The American Journal of Surgery*, vol. 181, No. 3, Apr. 2001, pp. 236-237.
- Peterson et al., "Comparison of Healing Process Following Ligation with Sutures and Bipolar Vessel Sealing" *Surgical Technology International* (2001).
- R. Gennari et al., (Jun. 2000) "Use of Technetium-99m-Labeled Colloid Albumin for Preoperative and Intraoperative Localization of Non palpable Breast Lesions," *American College of Surgeons*. 190(6):692-699.
- Valleylab Brochure, "Reducing Needlestick Injuries in the Operating Room" 1 pages, Mar. 2001.
- Reidenbach, (1995) "First Experimental Results with Special Applicators for High-Frequency Interstitial Thermotherapy", *Society Minimally Invasive Therapy*, 4(Suppl 1):40 (Abstr).
- Richard Wolf Medical Instruments Corp. Brochure, "Kleppinger Bipolar Forceps & Bipolar Generator" 3 pages, Jan. 1989.
- Rothenberg et al., "Use of the LigaSure.TM. Vessel Sealing System in Minimally Invasive Surgery in Children" *Int'l Pediatric Endosurgery Group (I PEG) 2000*.
- Sayfan et al., "Sutureless Closed Hemorrhoidectomy: A New Technique" *Annals of Surgery*, vol. 234, No. 1, Jul. 2001, pp. 21-24.
- Sengupta et al., "Use of a Computer-Controlled Bipolar Diathermy System in Radical Prostatectomies and Other Open Urological Surgery" *ANZ Journal of Surgery* (2001) 71.9 pp. 538-540.
- Sigel et al., "The Mechanism of Blood Vessel Closure by High Frequency Electrocoagulation" *Surgery Gynecology & Obstetrics*, Oct. 1965 pp. 823-831.
- Solbiati et al., (2001) "Percutaneous Radio-frequency Ablation of Hepatic Metastases from Colorectal Cancer: Long-term Results in 117 Patients", *Radiology*, vol. 221, pp. 159-166.
- Solbiati et al. (1995) "Percutaneous US-guided RF Tissue Ablation of Liver Metastases: Long-term Follow-up", *Radiology*, pp. 195-203.
- Strasberg et al., "Use of a Bipolar Vessel-Sealing Device for Parenchymal Transection During Liver Surgery" *Journal of Gastrointestinal Surgery*, vol. 6, No. 4, Jul./Aug. 2002 pp. 569-574.
- Stuart W. Young, *Nuclear Magnetic Resonance Imaging—Basic Principles*, Raven Press, New York, 1984.
- Sugita et al., "Bipolar Coagulator with Automatic Thermocontrol" *J. Neurosurg.*, vol. 41, Dec. 1944, pp. 777-779.
- Sylvain Labonte et al., "Monopole Antennas for Microwave Catheter Ablation", *IEEE Trans. on Microwave Theory and Techniques*, vol. 44, No. 10, pp. 1832-1840, Oct. 1995.
- T. Matsukawa et al., "Percutaneous Microwave Coagulation Therapy in Liver Tumors", *Acta Radiologica*, vol. 38, pp. 410-415, 1997.
- T. Seki et al., (1994) "Ultrasonically Guided Percutaneous Microwave Coagulation Therapy for Small Hepatocellular Carcinoma," *Cancer* 74(3):817.cndot.825.
- Urologix, Inc.—Medical Professionals: Targis.TM. Technology (Date Unknown). "Overcoming the Challenge" located at: <<http://www.urologix.com/medicaUtechnology.html>> Nov. 18, 1999; 3 pages.
- Urrutia et al., (1988). "Retractable-Barb Needle for Breast Lesion Localization: Use in 60 Cases," *Radiology* 169 (3):845-847.
- Valleylab Brochure, "Valleylab Electrosurgery Monitoring System" 2 pages, Nov. 1995.
- ValleyLab Brochure, "Electrosurgery: A Historical Overview", *Innovations in Electrosurgery*, 1999.
- Vallfors et al., "Automatically Controlled Bipolar Electrocoagulation—COA-COMP" *Neurosurgical Review* 7:2-3 (1984) pp. 187-190.
- W. Scott Helton, "LigaSure.TM. Vessel Sealing System: Revolutionary Hemostasis Product for General Surgery" *Sales/Product Literature* 1999.
- Wald et al., "Accidental Burns", *JAMA*, Aug. 16, 1971, vol. 217, No. 7, pp. 916-921.
- Walt Boyles, "Instrumentation Reference Book", 2002, Butterworth-Heinemann, pp. 262-264.
- Wonnell et al., "Evaluation of Microwave and Radio Frequency Catheter Ablation in a Myocardium-Equivalent Phantom Model", *IEEE Transactions on Biomedical Engineering*, vol. 39, No. 10, Oct. 1992; pp. 1086-1095.
- European Search Report EP 98300964.8 dated Dec. 13, 2000.

(56)

## References Cited

## OTHER PUBLICATIONS

- European Search Report EP 98944778 dated Nov. 7, 2000.
- European Search Report EP 98958575.7 dated Oct. 29, 2002.
- European Search Report EP 02786604.5 dated Feb. 10, 2010.
- European Search Report EP 03721482 dated Feb. 6, 2006.
- European Search Report EP 04009964 dated Jul. 28, 2004.
- European Search Report EP 04013772 dated Apr. 11, 2005.
- European Search Report EP 04015980 dated Nov. 3, 2004.
- European Search Report EP 04015981.6 dated Oct. 25, 2004.
- European Search Report EP 04027314 dated Mar. 31, 2005.
- European Search Report EP 04027479 dated Mar. 17, 2005.
- European Search Report EP 04027705 dated Feb. 10, 2005.
- European Search Report EP 04710258 dated Oct. 15, 2004.
- European Search Report EP 04752343.6 dated Jul. 31, 2007.
- European Search Report EP 12000334.8 dated May 4, 2012.
- European Search Report EP 12000335.5 dated May 10, 2012.
- European Search Report EP 12000336.3 dated May 14, 2012.
- European Search Report EP 12001841.1 dated Jul. 16, 2012.
- International Search Report PCT/US97/05066 dated Jun. 24, 1997.
- International Search Report PCT/US98/18640 dated Jan. 29, 1999.
- International Search Report PCT/US98/23950 dated Jan. 14, 1999.
- International Search Report PCT/US99/24869 dated Feb. 11, 2000.
- International Search Report PCT/US01/11218 dated Aug. 14, 2001.
- International Search Report PCT/US01/11224 dated Nov. 13, 2001.
- International Search Report PCT/US01/11340 dated Aug. 16, 2001.
- International Search Report PCT/US01/11420 dated Oct. 16, 2001.
- International Search Report PCT/US02/01890 dated Jul. 25, 2002.
- International Search Report PCT/US02/11100 dated Jul. 16, 2002.
- International Search Report PCT/US03/09483 dated Aug. 13, 2003.
- International Search Report PCT/US03/22900 dated Dec. 2, 2003.
- International Search Report PCT/US03/37110 dated Jul. 25, 2005.
- International Search Report PCT/US03/37111 dated Jul. 28, 2004.
- International Search Report PCT/US03/37310 dated Aug. 13, 2004.
- International Search Report PCT/US04/04685 dated Aug. 27, 2004.
- International Search Report PCT/US04/13273 dated Dec. 15, 2004.
- International Search Report PCT/US04/15311 dated Jan. 12, 2005.
- International Search Report PCT/US05/36168 dated Aug. 28, 2006.
- International Search Report PCT/US08/052460 dated Apr. 24, 2008.
- International Search Report PCT/US09/31658 dated Mar. 11, 2009.
- International Search Report PCT/US10/032796 dated Jul. 28, 2010.
- B. F. Mullan et al., (May 1999) "Lung Nodules: Improved Wire for CT-Guided Localization," *Radiology* 211:561-565.
- B. T. Heniford M.D. et al., "Initial Research and Clinical Results with an Electrothermal Bipolar Vessel Sealer" Oct. 1999.
- Bergdahl et al., "Studies on Coagulation and the Development of an Automatic Computerized Bipolar Coagulator" *Journal of Neurosurgery* 75:1 (Jul. 1991), pp. 148-151.
- Bulletin of the American Physical Society, vol. 47, No. 5, Aug. 2002, p. 41.
- C. F. Gottlieb et al., "Interstitial Microwave Hyperthermia Applicators having Submillimetre Diameters", *Int. J. Hyperthermia*, vol. 6, No. 3, pp. 707-714, 1990.
- C. H. Durney et al., "Antennas for Medical Applications", *Antenna Handbook: Theory Application and Design*, p. 24-40, Van Nostrand Reinhold, 1988 New York, V.T. Lo, S.W. Lee.
- Carbonell et al., "Comparison of the Gyros PlasmaKinetic Sealer and the Valleylab LigaSure.TM. Device in the Hemostasis of Small, Medium, and Large-Sized Arteries" *Carolinas Laparoscopic and Advanced Surgery Program, Carolinas Medical Center, Charlotte, NC* 2003.
- Carus et al., "Initial Experience With the LigaSure.TM. Vessel Sealing System in Abdominal Surgery" *Innovations That Work*, Jun. 2002.
- Chicharo et al., "A Sliding Goertzel Algorithm" Aug. 1996 DOS pp. 283-297 *Signal Processing*, Elsevier Science Publishers B.V. Amsterdam, NL, vol. 52, No. 3.
- Chou, C.K., (1995) "Radiofrequency Hyperthermia in Cancer Therapy," Chapter 94 In *Biologic Effects of Nonionizing Electromagnetic Fields*, CRC Press, Inc., pp. 1424-1428.
- Chung et al., "Clinical Experience of Sutureless Closed Hemorrhoidectomy with LigaSure.TM." *Diseases of the Colon & Rectum*, vol. 46, No. 1, Jan. 2003.
- Cosman et al., "Methods of Making Nervous System Lesions" in William RH, Rengachary SS (eds): *Neurosurgery*, New York: McGraw.Hill, vol. 111, (1984), pp. 2490-2499.
- Cosman et al., "Radiofrequency Lesion Generation and its Effect on Tissue Impedance", *Applied Neurophysiology*, 51:230-242, 1988.
- Cosman et al., "Theoretical Aspects of Radiofrequency Lesions in the Dorsal Root Entry Zone" *Neurosurgery* 15; (1984), pp. 945-950.
- Crawford et al., "Use of the LigaSure.TM. Vessel Sealing System in Urologic Cancer Surger" *Grand Rounds in Urology* 1999, vol. 1, Issue 4, pp. 10-17.
- Dulemba et al., "Use of a Bipolar Electrothermal Vessel Sealer in Laparoscopically Assisted Vaginal Hysterectomy" *Sales/Product Literature*; Jan. 2004.
- E. David Crawford, "Evaluation of a New Vessel Sealing Device in Urologic Cancer Surgery" *Sales/Product Literature* 2000.
- E. David Crawford, "Use of a Novel Vessel Sealing Technology in Management of the Dorsal Venous Complex" *Sales/Product Literature* 2000.
- Esterline, "Light Key Projection Keyboard" *Advanced Input Systems*, located at: <<http://www.advanced-input.com/lightkey>> 2002.
- Esterline Product Literature, "Light Key: Visualize a Virtual Keyboard. One With No Moving Parts", Nov. 1, 2003; 4 pages.
- Geddes et al., "The Measurement of Physiologic Events by Electrical Impedance" *Am. J. MI*, Jan. Mar. 1964, pp. 16-27.
- Goldberg et al., "Image-guided Radiofrequency Tumor Ablation: Challenges and Opportunities—Part I", (2001) *J Vasc. Interv. Radiol*, vol. 12, pp. 1021-1032.
- Goldberg et al. (1995) "Saline-enhanced RF Ablation: Demonstration of Efficacy and Optimization of Parameters", *Radiology*, 197(P): 140 (Abstr).
- Goldberg et al., "Tissue Ablation with Radiofrequency: Effect of Probe Size, Gauge, Duration, and Temperature on Lesion Volume" *Acad Radio* (1995) vol. 2, No. 5, pp. 399-404.
- H. Schwarzmaier et al., "Magnetic Resonance Imaging of Microwave Induced Tissue Heating" *Dept. of Laser Medicine & Dept. of Diagnostic Radiology; Heinrich-Heine-University, Duesseldorf, Germany*; Dec. 8, 1994; pp. 729-731.
- Heniford et al., "Initial Results with an Electrothermal Bipolar Vessel Sealer" *Surgical Endoscopy* (2001) 15:799-801.
- Herman et al., "Laparoscopic Intestinal Resection With the LigaSure.TM. Vessel Sealing System: A Case Report" *Innovations That Work*, Feb. 2002.
- Humphries Jr. et al., "Finite Element Codes to Model Electrical Heating and Non-linear Thermal Transport in Biological Media", *Proc. ASME HTD-355*, 131 (1997).
- Ian D. McRury et al., "The Effect of Ablation Sequence and Duration on Lesion Shape Using Rapidly Pulsed Radiofrequency Energy Through Electrodes, Feb. 2000, *Springer Netherlands*, vol. 4; No. 1, pp. 307-320.
- Jarrett et al., "Use of the LigaSure.TM. Vessel Sealing System for Peri-Hilar Vessels in Laparoscopic Nephrectomy" *Sales/Product Literature* 2000.
- Johnson et al., "Evaluation of a Bipolar Electrothermal Vessel Sealing Device in Hemorrhoidectomy" *Sales/Product Literature*, Jan. 2004.
- Johnson, "Evaluation of the LigaSure.TM. Vessel Sealing System in Hemorrhoidectomy" *American College of Surgeons (ACS) Clinic La Congress Poster* (2000).
- Johnson et al., "New Low-Profile Applicators for Local Heating of Tissues", *IEEE Transactions on Biomedical Engineering*, vol. BME-31, No. 1, Jan. 1984, pp. 28-37.
- Johnson, "Use of the LigaSure.TM. Vessel Sealing System in Bloodless Hemorrhoidectomy" *Innovations That Work*, Mar. 2000.
- Joseph G. Andriole M.D. et al., "Biopsy Needle Characteristics Assessed in the Laboratory", *Radiology* 148: 659-662, Sep. 1983.
- Joseph Ortenberg, "LigaSure.TM. System Used in Laparoscopic 1st and 2nd Stage Orchiopexy" *Innovations That Work*, Nov. 2002.
- K. Ogata, *Modern Control Engineering*, Prentice-Hall, Englewood Cliffs, N.J., 1970.

(56)

## References Cited

## OTHER PUBLICATIONS

- Kennedy et al., "High-burst-strength, feedback-controlled bipolar vessel sealing" *Surgical Endoscopy* (1998) 12: 876-878.
- Kopans, D.B. et al., (Nov. 1985) "Spring Hookwire Breast Lesion Localizer: Use with Rigid-Compression. Mammographic Systems," *Radiology* 157(2):537-538.
- Koyle et al., "Laparoscopic Palomo Varicocele Ligation in Children and Adolescents" *Pediatric Endosurgery & Innovative Techniques*, vol. 6, No. 1, 2002.
- LigaSure.TM. Vessel Sealing System, the Seal of Confidence in General, Gynecologic, Urologic, and Laparoscopic Surgery, Sales/Product Literature, Jan. 2004.
- Livraghi et al., (1995) "Saline-enhanced RF Tissue Ablation in the Treatment of Liver Metastases", *Radiology*, p. 140 (Abstr).
- Lyndon B. Johnson Space Center, Houston, Texas, "Compact Directional Microwave Antenna for Localized Heating," NASA Tech Briefs, Mar. 2008.
- M. A. Astrahan, "A Localized Current Field Hyperthermia System for Use with 192-Iridium Interstitial Implants" *Medical Physics*. 9(3), May/June. 1982.
- Magdy F. Iskander et al., "Design Optimization of Interstitial Antennas", *IEEE Transactions on Biomedical Engineering*, vol. 36, No. 2, Feb. 1989, pp. 238-246.
- McGahan et al., (1995) "Percutaneous Ultrasound-guided Radiofrequency Electrocautery Ablation of Prostate Tissue in Dogs", *Acad Radiol*, vol. 2, No. 1: pp. 61-65.
- McLellan et al., "Vessel Sealing for Hemostasis During Pelvic Surgery" *Int'l Federation of Gynecology and Obstetrics FIGO World Congress 2000*, Washington, DC.
- MDTECH product literature (Dec. 1999) "FlexStrand": product description, 1 page.
- MDTECH product literature (Mar. 2000) I'D Wire: product description, 1 page.
- Medtrex Brochure "The O.R. Pro 300" 1 page, Sep. 1998.
- U.S. Appl. No. 13/419,981, filed Mar. 14, 2012, Joseph D. Brannan.
- U.S. Appl. No. 13/430,810, filed Mar. 27, 2012, Joseph D. Brannan.
- U.S. Appl. No. 13/440,690, filed Apr. 5, 2012, Joseph D. Brannan.
- U.S. Appl. No. 13/460,440, filed Apr. 30, 2012, Arnold V. DeCarlo.
- U.S. Appl. No. 13/464,021, filed May 4, 2012, Joseph D. Brannan.
- U.S. Appl. No. 13/477,260, filed May 22, 2012, William R. Reid, Jr.
- U.S. Appl. No. 13/477,320, filed May 22, 2012, Joseph D. Brannan.
- U.S. Appl. No. 13/711,086, filed Dec. 11, 2012, Brannan.
- U.S. Appl. No. 13/835,183, filed Mar. 15, 2013, Arts.
- U.S. Appl. No. 13/835,513, filed Mar. 15, 2013, Brannan.
- U.S. Appl. No. 13/836,014, filed Mar. 15, 2013, Arts.
- U.S. Appl. No. 13/836,353, filed Mar. 15, 2013, Arts.
- U.S. Appl. No. 13/839,562, filed Mar. 15, 2013, Zheng.
- U.S. Appl. No. 13/867,834, filed Jul. 22, 2013, Brannan.
- U.S. Appl. No. 13/871,142, filed Apr. 26, 2013, Ohri.
- U.S. Appl. No. 13/886,080, filed May 2, 2013, Bahney.
- U.S. Appl. No. 13/889,989, filed May 8, 2013, Lee.
- U.S. Appl. No. 13/903,668, filed May 28, 2013, Podhajsky.
- U.S. Appl. No. 13/904,478, filed May 29, 2013, Ohri.
- U.S. Appl. No. 13/908,463, filed Jun. 3, 2013, Brannan.
- U.S. Appl. No. 13/908,555, filed Jun. 3, 2013, Dunning.
- U.S. Appl. No. 13/920,367, filed Jun. 18, 2013, Sharonov.
- U.S. Appl. No. 13/920,411, filed Jun. 18, 2013, Sharonov.
- U.S. Appl. No. 13/922,006, filed Jun. 19, 2013, Nau.
- U.S. Appl. No. 13/942,833, filed Jul. 16, 2013, Sharonov.
- U.S. Appl. No. 13/942,864, filed Jul. 16, 2013, Sharonov.
- U.S. Appl. No. 13/943,452, filed Jul. 16, 2013, Behnke.
- U.S. Appl. No. 13/945,519, filed Jul. 18, 2013, Prakash.
- U.S. Appl. No. 13/945,718, filed Jul. 18, 2013, Rossetto.
- U.S. Appl. No. 13/957,087, filed Aug. 1, 2013, Brannan.
- U.S. Appl. No. 13/973,543, filed Aug. 22, 2013, Orszulak.
- U.S. Appl. No. 14/011,414, filed Aug. 27, 2013, Ohri.
- U.S. Appl. No. 14/011,438, filed Aug. 27, 2013, Ohri.
- U.S. Appl. No. 14/014,937, filed Aug. 30, 2013, Willyard.
- U.S. Appl. No. 14/017,995, filed Sep. 4, 2013, Brannan.
- U.S. Appl. No. 14/018,081, filed Sep. 4, 2013, Brannan.
- European Search Report EP 09161502.1 extended dated Oct. 30, 2009.
- European Search Report EP 09165976.3 extended dated Mar. 17, 2010.
- European Search Report EP 09166708 dated Oct. 15, 2009.
- European Search Report EP 09166708.9 dated Mar. 18, 2010.
- European Search Report EP 09169376.2 extended dated Dec. 16, 2009.
- European Search Report EP 09172188.6 extended dated Apr. 23, 2010.
- European Search Report EP 09172838.6 extended dated Jan. 20, 2010.
- European Search Report EP 09173268.5 extended dated Jan. 27, 2010.
- European Search Report EP 09704429.1 extended dated Mar. 23, 2011.
- European Search Report EP 10001767.2 extended dated Jun. 18, 2010.
- European Search Report EP 10004950.1 extended dated Jul. 2, 2010.
- European Search Report EP 10004951.9 extended dated Jul. 2, 2010.
- European Search Report EP 10005533.4 extended dated Sep. 24, 2010.
- European Search Report EP 10005534.2 extended dated Sep. 17, 2010.
- European Search Report EP 10006373.4 extended dated Oct. 11, 2010.
- European Search Report EP 10008139.7 extended dated Nov. 30, 2010.
- European Search Report EP 10008140.5 extended dated Dec. 28, 2010.
- European Search Report EP 10008533.1 extended dated Dec. 20, 2010.
- European Search Report EP 10008850.9 extended dated Nov. 30, 2010.
- European Search Report EP 10009392.1 extended dated Sep. 19, 2011.
- European Search Report EP 10009731.0 extended dated Jan. 28, 2011.
- European Search Report EP 10009732.8 extended dated Jan. 26, 2011.
- European Search Report EP 10010943.8 extended dated Feb. 1, 2011.
- European Search Report EP 10011750.6 extended dated Feb. 1, 2011.
- European Search Report EP 10014042.5 extended dated Feb. 18, 2011.
- European Search Report EP 10014080.5 extended dated Mar. 17, 2011.
- European Search Report EP 10014081.3 extended dated Mar. 17, 2011.
- European Search Report EP 10014705.7 extended dated Apr. 27, 2011.
- European Search Report EP 10158944.8 extended dated Jun. 21, 2010.
- European Search Report EP 10161596.1 extended dated Jul. 28, 2010.
- European Search Report EP 10161722.3 extended dated Jun. 16, 2010.
- European Search Report EP 10163235.4 dated Aug. 10, 2010.
- European Search Report EP 10172634.7 dated Nov. 9, 2010.
- European Search Report EP 10185413.1 dated Dec. 7, 2010.
- European Search Report EP 10185413.1 dated Mar. 14, 2011.
- European Search Report EP 10191321.8 dated Apr. 7, 2011.
- European Search Report EP 11000548.5 extended dated Apr. 14, 2011.
- European Search Report EP 11000669.9 extended dated Jun. 30, 2011.
- European Search Report EP 11001596.3 extended dated Jul. 4, 2011.
- European Search Report EP 11001872.8 extended dated Jul. 6, 2011.
- European Search Report EP 11004942 dated Oct. 4, 2011.
- European Search Report EP 11009036.2 dated Feb. 13, 2012.
- European Search Report EP 11010024.5 dated Apr. 20, 2012.
- European Search Report EP 11010046.8 dated Apr. 17, 2012.

(56)

## References Cited

## OTHER PUBLICATIONS

- European Search Report EP 11010093.0 dated Mar. 27, 2012.  
European Search Report EP 11010175.5 dated May 10, 2012.  
European Search Report EP 11010176.3 dated Apr. 2, 2012.  
European Search Report EP 11010177.1 dated May 10, 2012.  
European Search Report EP 11174318.3 dated Nov. 7, 2011.  
European Search Report EP 11185926.0 dated Feb. 3, 2012.  
European Search Report EP 04778192.7 dated Jul. 1, 2009.  
European Search Report EP 05002027.0 dated May 12, 2005.  
European Search Report EP 05002769.7 dated Jun. 19, 2006.  
European Search Report EP 05013463.4 dated Oct. 7, 2005.  
European Search Report EP 05013895 dated Oct. 21, 2005.  
European Search Report EP 05014156.3 dated Jan. 4, 2006.  
European Search Report EP 05016399 dated Jan. 13, 2006.  
European Search Report EP 05017281 dated Nov. 24, 2005.  
European Search Report EP 05019130.3 dated Oct. 27, 2005.  
European Search Report EP 05019882 dated Feb. 16, 2006.  
European Search Report EP 05020665.5 dated Feb. 27, 2006.  
European Search Report EP 05020666.3 dated Feb. 27, 2006.  
European Search Report EP 05021025.1 dated Mar. 13, 2006.  
European Search Report EP 05021197.8 dated Feb. 20, 2006.  
European Search Report EP 05021777 dated Feb. 23, 2006.  
European Search Report EP 05021779.3 dated Feb. 2, 2006.  
European Search Report EP 05021780.1 dated Feb. 23, 2006.  
European Search Report EP 05021935 dated Jan. 27, 2006.  
European Search Report EP 05021936.9 dated Feb. 6, 2006.  
European Search Report EP 05021937.7 dated Jan. 23, 2006.  
European Search Report EP 05021939 dated Jan. 27, 2006.  
European Search Report EP 05021944.3 dated Jan. 25, 2006.  
European Search Report EP 05022350.2 dated Jan. 30, 2006.  
European Search Report EP 05023017.6 dated Feb. 24, 2006.  
European Search Report EP 05025423.4 dated Jan. 19, 2007.  
European Search Report EP 05025424 dated Jan. 30, 2007.  
European Search Report EP 05810523 dated Jan. 29, 2009.  
European Search Report EP 06000708.5 dated May 15, 2006.  
European Search Report EP 06002279.5 dated Mar. 30, 2006.  
European Search Report EP 06005185.1 dated May 10, 2006.  
European Search Report EP 06005540 dated Sep. 24, 2007.  
European Search Report EP 06006717.0 dated Aug. 11, 2006.  
European Search Report EP 06006961 dated Oct. 22, 2007.  
European Search Report EP 06006963 dated Aug. 4, 2006.  
European Search Report EP 06008779.8 dated Jul. 13, 2006.  
European Search Report EP 06009435 dated Jul. 13, 2006.  
European Search Report EP 06010499.9 dated Jan. 29, 2008.  
European Search Report EP 06014461.5 dated Oct. 31, 2006.  
European Search Report EP 06018206.0 dated Oct. 20, 2006.  
European Search Report EP 06019768 dated Jan. 17, 2007.  
European Search Report EP 06020574.7 dated Oct. 2, 2007.  
European Search Report EP 06020583.8 dated Feb. 7, 2007.  
European Search Report EP 06020584.6 dated Feb. 1, 2007.  
European Search Report EP 06020756.0 dated Feb. 16, 2007.  
European Search Report EP 06022028.2 dated Feb. 13, 2007.  
European Search Report EP 06023756.7 dated Feb. 21, 2008.  
European Search Report EP 06024122.1 dated Apr. 16, 2007.  
European Search Report EP 06024123.9 dated Mar. 6, 2007.  
European Search Report EP 06025700.3 dated Apr. 12, 2007.  
European Search Report EP 07000885.9 dated May 15, 2007.  
European Search Report EP 07001480.8 dated Apr. 19, 2007.  
European Search Report EP 07001481.6 dated May 2, 2007.  
European Search Report EP 07001485.7 dated May 23, 2007.  
European Search Report EP 07001488.1 dated Jun. 5, 2007.  
European Search Report EP 07001489.9 dated Dec. 20, 2007.  
European Search Report EP 07001491 dated Jun. 6, 2007.  
European Search Report EP 07001527.6 dated May 18, 2007.  
European Search Report EP 07007783.9 dated Aug. 14, 2007.  
European Search Report EP 07008207.8 dated Sep. 13, 2007.  
European Search Report EP 07009026.1 dated Oct. 8, 2007.  
European Search Report EP 07009028 dated Jul. 16, 2007.  
European Search Report EP 07009029.5 dated Jul. 20, 2007.  
European Search Report EP 07009321.6 dated Aug. 28, 2007.  
European Search Report EP 07009322.4 dated Jan. 14, 2008.  
European Search Report EP 07010672.9 dated Oct. 16, 2007.  
European Search Report EP 07010673.7 dated Oct. 5, 2007.  
European Search Report EP 07013779.9 dated Oct. 26, 2007.  
European Search Report EP 07015191.5 dated Jan. 23, 2008.  
European Search Report EP 07015601.3 dated Jan. 4, 2008.  
European Search Report EP 07015602.1 dated Dec. 20, 2007.  
European Search Report EP 07018375.1 dated Jan. 8, 2008.  
European Search Report EP 07018821 dated Jan. 14, 2008.  
European Search Report EP 07019173.9 dated Feb. 12, 2008.  
European Search Report EP 07019174.7 dated Jan. 29, 2008.  
European Search Report EP 07019178.8 dated Feb. 12, 2008.  
European Search Report EP 07020283.3 dated Feb. 5, 2008.  
European Search Report EP 07253835.8 dated Dec. 20, 2007.  
European Search Report EP 08001016.8 dated Jan. 4, 2008.  
European Search Report EP 08001019 dated Sep. 23, 2008.  
European Search Report EP 08004974.5 dated Apr. 6, 2011.  
European Search Report EP 08004975 dated Jul. 24, 2008.  
European Search Report EP 08006731.7 dated Jul. 29, 2008.  
European Search Report EP 08006733 dated Jul. 7, 2008.  
European Search Report EP 08006734.1 dated Aug. 18, 2008.  
European Search Report EP 08006735.8 dated Jan. 8, 2009.  
European Search Report EP 08007924.7 partial dated Aug. 17, 2010.  
European Search Report EP 08011282 dated Aug. 14, 2009.  
European Search Report EP 08011705 dated Aug. 20, 2009.  
European Search Report EP 08011705.4 extended dated Nov. 4, 2009.  
European Search Report EP 08012829.1 dated Oct. 29, 2008.  
European Search Report EP 08015842 dated Dec. 5, 2008.  
European Search Report EP 08019920.1 dated Mar. 27, 2009.  
European Search Report EP 08020530.5 dated May 27, 2009.  
European Search Report EP 08169973.8 dated Apr. 6, 2009.  
European Search Report EP 09010873.9 extended dated Nov. 13, 2009.  
European Search Report EP 09010877.0 extended dated Dec. 3, 2009.  
European Search Report EP 09012389.4 dated Jul. 6, 2010.  
European Search Report EP 09151621 dated Jun. 18, 2009.  
European Search Report EP 09156861.8 dated Aug. 4, 2009.  
European Search Report EP 09161502.1 dated Sep. 2, 2009.  
US Appl. No. 08/136,098, filed Oct. 14, 1993, Roger A. Stern.  
U.S. Appl. No. 08/483,742, filed Jun. 7, 1995, Roger A. Stern.  
U.S. Appl. No. 13/050,729, filed Mar. 17, 2011, Casey M. Ladtkow.  
U.S. Appl. No. 13/083,185, filed Apr. 8, 2011, Arnold V. DeCarlo.  
U.S. Appl. No. 13/083,256, filed Apr. 8, 2011, Joseph D. Brannan.  
U.S. Appl. No. 13/113,736, filed May 23, 2011, Ladtkow et al.  
U.S. Appl. No. 13/118,929, filed May 31, 2011, Bonn et al.  
U.S. Appl. No. 13/206,075, filed Aug. 9, 2011, Lee et al.  
U.S. Appl. No. 13/236,997, filed Sep. 20, 2011, Behnke II, et al.  
U.S. Appl. No. 13/237,068, filed Sep. 20, 2011, Behnke II, et al.  
U.S. Appl. No. 13/237,187, filed Sep. 20, 2011, Behnke II, et al.  
U.S. Appl. No. 13/237,342, filed Sep. 20, 2011, Behnke II, et al.  
U.S. Appl. No. 13/237,488, filed Sep. 20, 2011, Behnke II, et al.  
U.S. Appl. No. 13/343,788, filed Jan. 5, 2012, William O. Reid Jr.  
U.S. Appl. No. 13/343,798, filed Jan. 5, 2012, William O. Reid Jr.  
U.S. Appl. No. 13/344,753, filed Jan. 6, 2012, Lee et al.  
U.S. Appl. No. 13/344,790, filed Jan. 6, 2012, Lee et al.  
U.S. Appl. No. 13/400,223, filed Feb. 20, 2012, Anthony B. Ross.  
U.S. Appl. No. 13/477,307, filed May 22, 2012, Casey M. Ladtkow.  
U.S. Appl. No. 13/483,858, filed May 30, 2012, Francesca Rossetto.  
U.S. Appl. No. 13/488,964, filed Jun. 5, 2012, Steven P. Buysse.  
U.S. Appl. No. 13/525,853, filed Jun. 18, 2012, Joseph A. Paulus.  
U.S. Appl. No. 13/526,676, filed Jun. 19, 2012, Francesca Rossetto.  
U.S. Appl. No. 13/539,650, filed Jul. 2, 2012, Joseph A. Paulus.  
U.S. Appl. No. 13/539,690, filed Jul. 2, 2012, Steven P. Buysse.  
U.S. Appl. No. 13/539,725, filed Jul. 2, 2012, Steven P. Buysse.  
U.S. Appl. No. 13/539,875, filed Jul. 2, 2012, Mani N. Prakash.  
U.S. Appl. No. 13/551,005, filed Jul. 17, 2012, Chris Rusin.  
U.S. Appl. No. 13/567,624, filed Aug. 6, 2012, Mani N. Prakash.  
U.S. Appl. No. 13/568,679, filed Aug. 7, 2012, Robert J. Behnke, II.  
U.S. Appl. No. 13/596,785, filed Aug. 28, 2012, Richard A. Willyard.  
U.S. Appl. No. 13/598,141, filed Aug. 29, 2012, Kenlyn S. Bonn.

(56)

**References Cited**

OTHER PUBLICATIONS

Alexander et al., "Magnetic Resonance Image-Directed Stereotactic Neurosurgery: Use of Image Fusion with Computerized Tomography to Enhance Spatial Accuracy" *Journal Neurosurgery*, 83 (1995), pp. 271-276.

Anderson et al., "A Numerical Study of Rapid Heating for High Temperature Radio Frequency Hyperthermia" *International Journal of Bio-Medical Computing*, 35 (1994), pp. 297-307.

Anonymous. (1999) Auto Suture MIBB Site Marker: Single Use Clip Applier, United States Surgical (Product instructions), 2 pages.

Anonymous. (2001) Disposable Chiba Biopsy Needles and Trays, Biopsy and Special Purpose Needles Cook Diagnostic and Interventional Products Catalog (products list), 4 pages.

Anonymous. (1987) Homer Mammalok.TM. Breast Lesion Needle/Wire Localizer, Namic.RTM. Angiographic Systems Division, Glens Falls, New York, (Hospital products price list), 4 pages.

Anonymous. (1999) MIBB Site Marker, United States Surgical (Sales brochure), 4 pages.

Anonymous. Blunt Tubes with Finished Ends. Pointed Cannula, Popper & Sons Biomedical Instrument Division, (Products Price List), one page, Jul. 19, 2000.

Anonymous. Ground Cannulae, ISPG, New Milford, CT, (Advertisement) one page, Jul. 19, 2000.

B. Levy M.D. et al., "Randomized Trial of Suture Versus Electrosurgical Bipolar Vessel Sealing in Vaginal Hysterectomy" *Obstetrics & Gynecology*, vol. 102, No. 1, Jul. 2003.

B. Levy M.D. et al., "Update on Hysterectomy New Technologies and Techniques" *OBG Management*, Feb. 2003.

B. Levy M.D., "Use of a New Vessel Ligation Device During Vaginal Hysterectomy" FIGO 2000, Washington, D.C.

\* cited by examiner

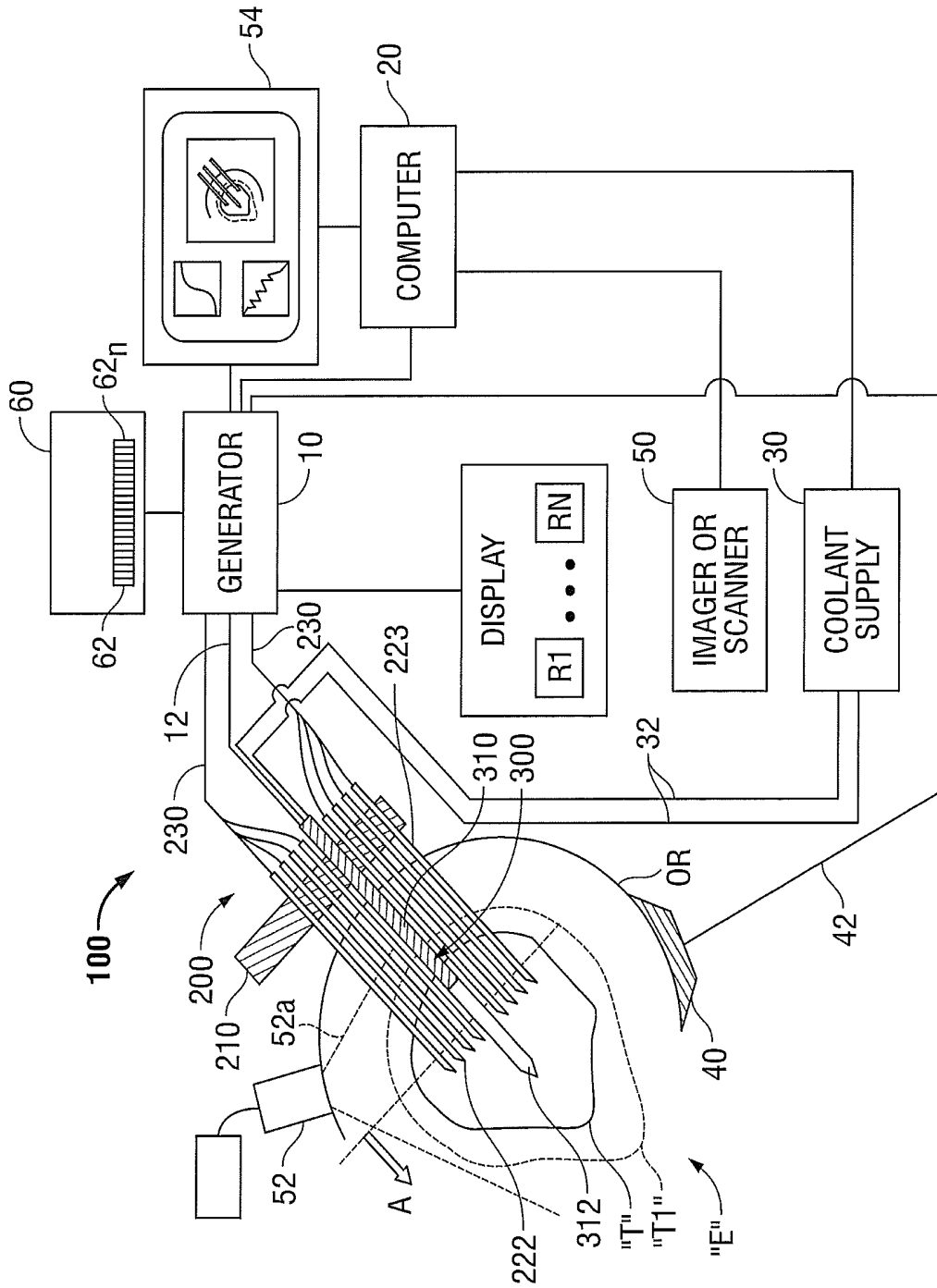

FIG. 1

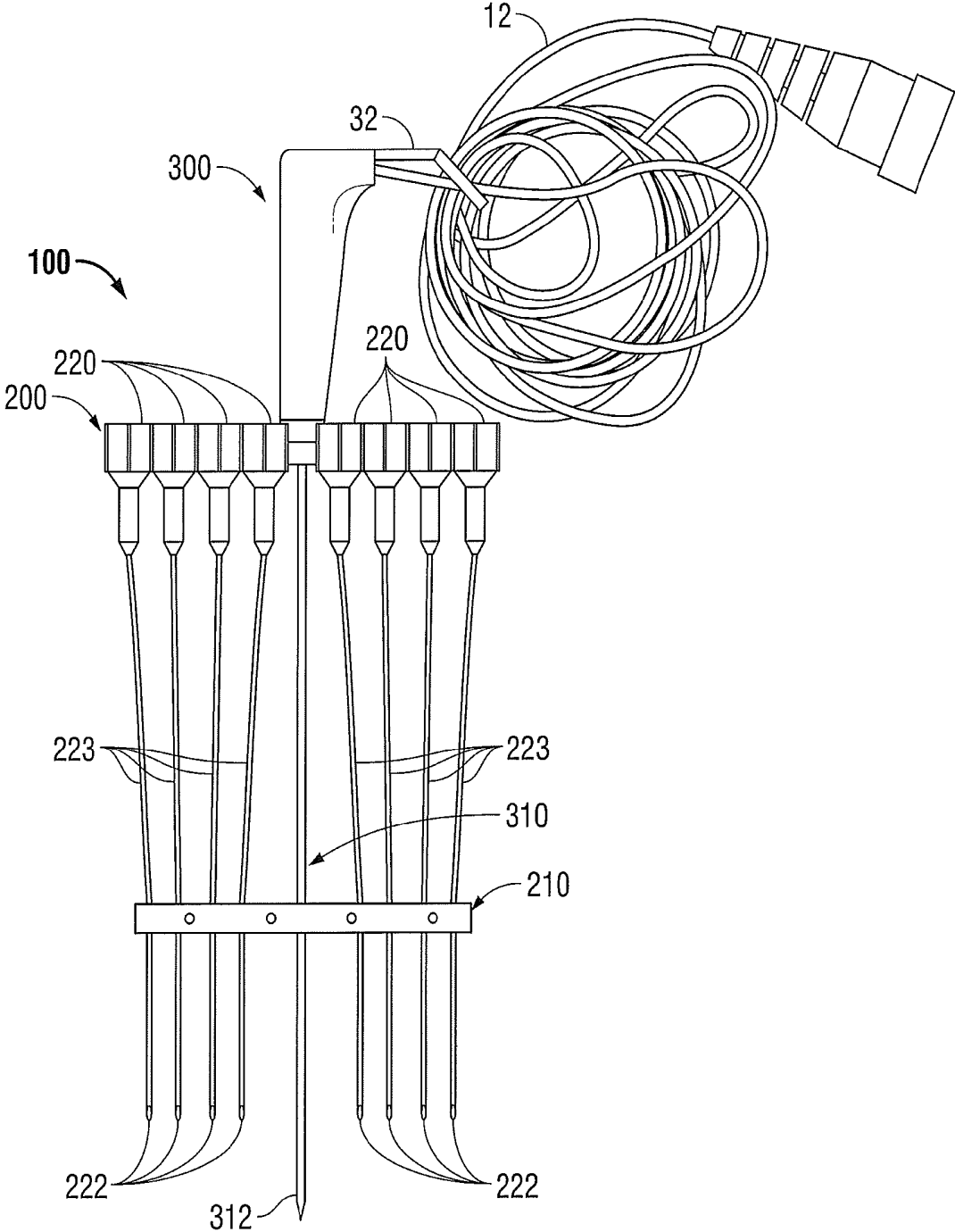

FIG. 2

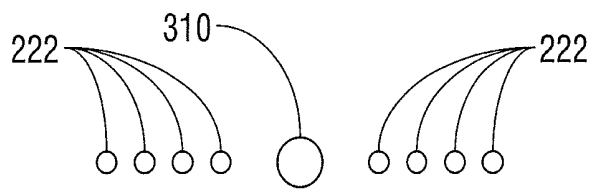

FIG. 2A

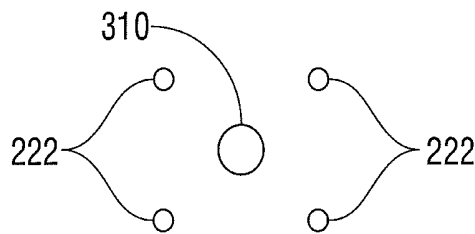

FIG. 2B

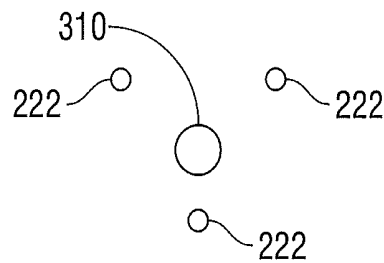

FIG. 2C

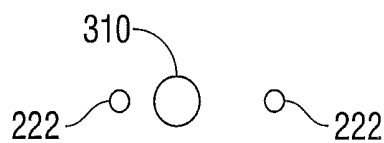

FIG. 2D

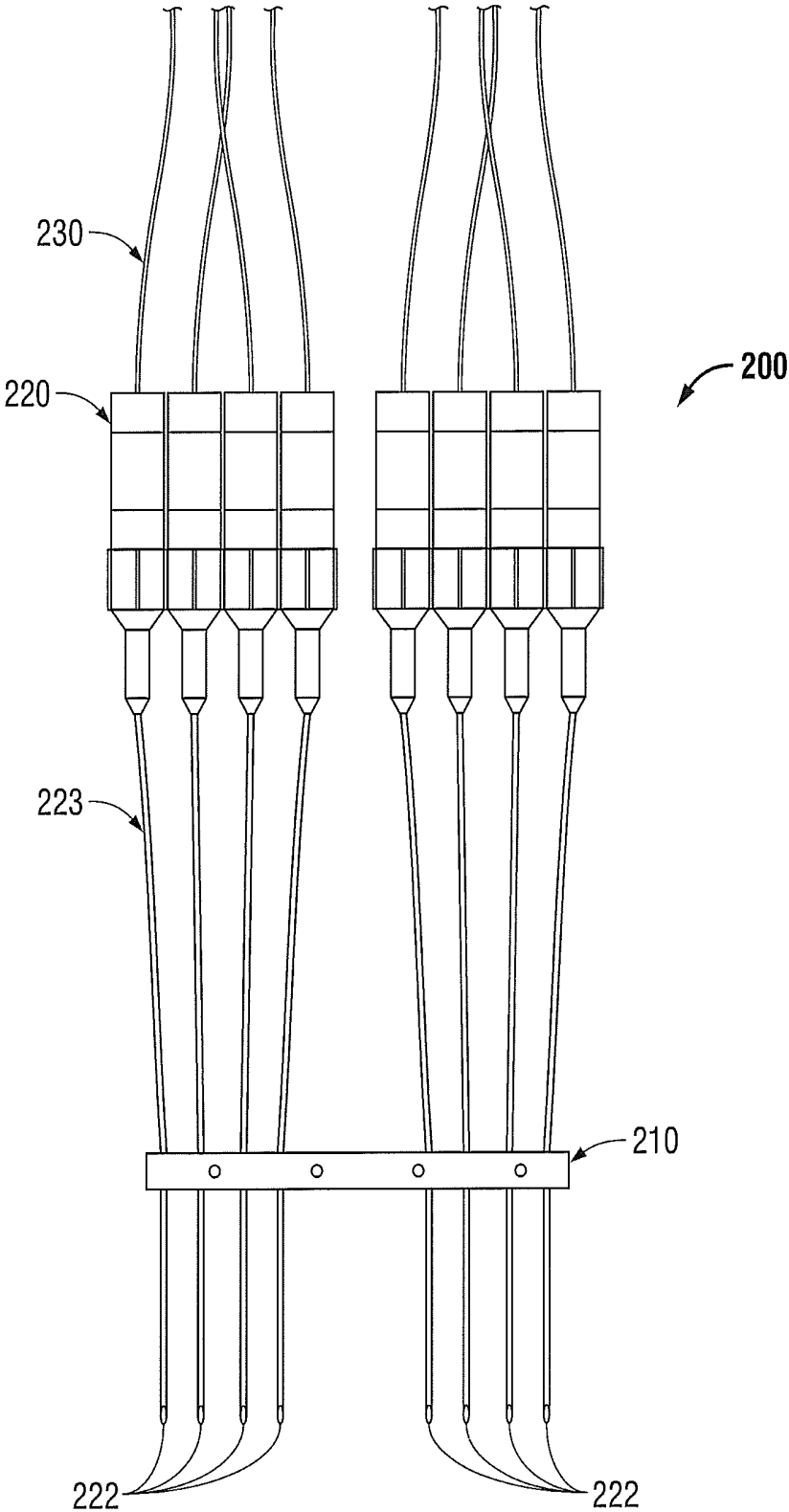

FIG. 3

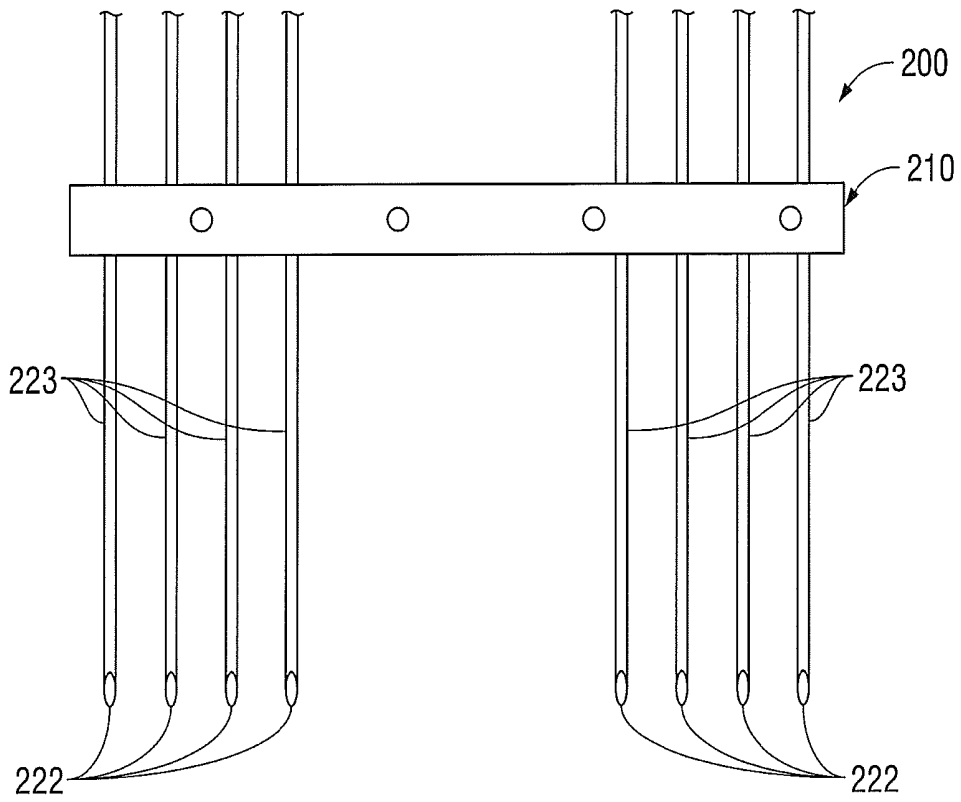

FIG. 4

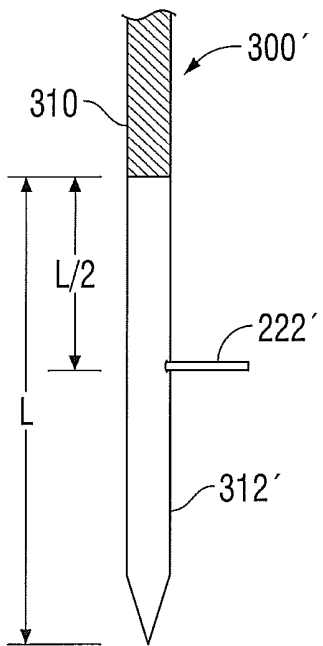

FIG. 5

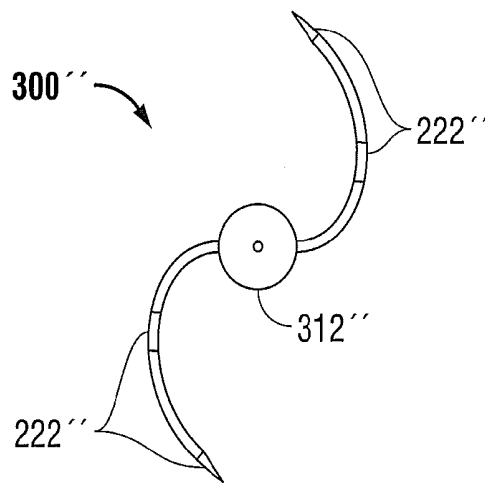

FIG. 6

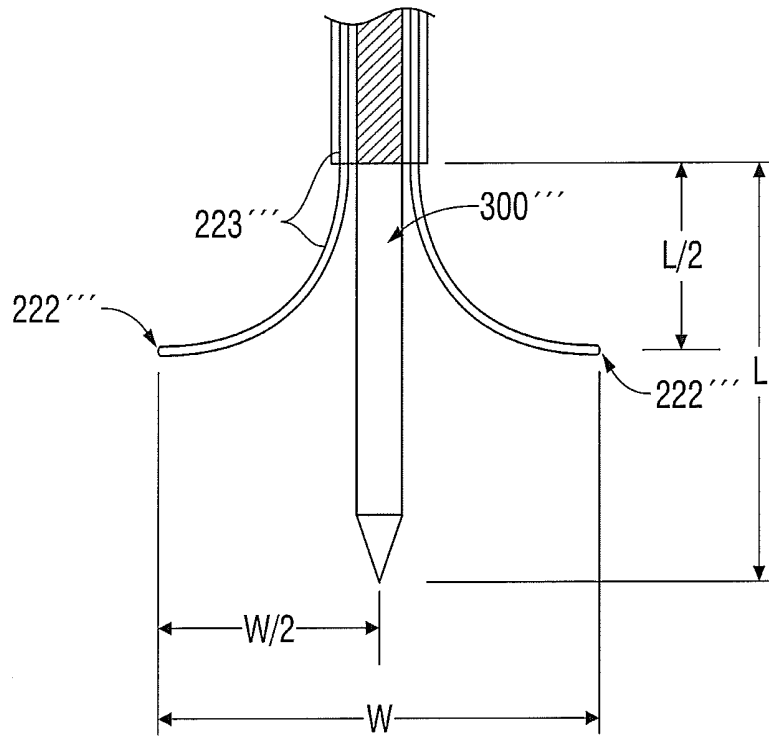

FIG. 7A

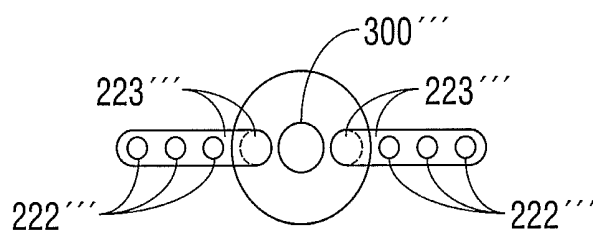

FIG. 7B

## THERMAL FEEDBACK SYSTEMS AND METHODS OF USING THE SAME

### CROSS-REFERENCE TO RELATED APPLICATIONS

The present application is a continuation application of U.S. patent application Ser. No. 13/539,725, now U.S. Pat. No. 8,568,402, filed Jul. 2, 2012, which is a divisional application of U.S. patent application Ser. No. 12/023,606, now U.S. Pat. No. 8,211,099, filed Jan. 31, 2008, which claims the benefit of and priority to U.S. Provisional Application Ser. No. 60/887,537, filed on Jan. 31, 2007, the entire contents of all of which are incorporated by reference herein.

### BACKGROUND

#### 1. Technical Field

The present disclosure relates to energy delivery feedback systems and, more particularly to thermal feedback systems for electrosurgical energy systems and methods of their use.

#### 2. Background of Related Art

The use of electrical energy including radiofrequency and microwave energy ("RF & MW energy") and, in particular, radiofrequency electrodes or microwave antennae ("RF-electrodes/MW-antennae") for ablation of tissue in the body or for the treatment of pain is known. Generally, such RF electrodes (e.g., probes, resistive heating elements and the like) include an elongated cylindrical configuration for insertion into the body to target tissue which is to be treated or ablated. The RF electrodes can further include an exposed conductive tip portion and an insulated portion. The RF electrodes can also include a method of internal cooling (e.g., a Cool-tip™ or the like), such as the RF electrodes shown and described in U.S. Pat. No. 6,506,189 entitled "COOL-TIP ELECTRODE THERMOSURGERY SYSTEM" issued to Rittman, III et al., on Jan. 14, 2003 and U.S. Pat. No. 6,530,922 entitled "CLUSTER ABLATION ELECTRODE SYSTEM" issued to Cosman et al., on Mar. 11, 2003, the entire content of which is incorporated herein by reference. Accordingly, when the RF electrode is connected to an external source of radiofrequency power, e.g., an electrosurgical generator (device used to generate therapeutic energy such as radiofrequency (RF), microwave (MW) or ultrasonic (US)), and current is delivered to the RF electrode, heating of tissue occurs near and around the exposed conductive tip portion thereof, whereby therapeutic changes in the target tissue, near the conductive tip, are created by the elevation of temperature of the tissue.

In some applications, for example, tumor ablation procedures, multiple electrodes are inserted into the body in an array to enlarge ablation volumes.

In a particular application, arrays of high frequency electrodes are inserted into tumors. The electrodes are typically placed in a dispersed fashion throughout the tumor volume to cover the tumor volume with uniform heat. The multiple electrodes may be activated simultaneously or sequentially applied with high frequency energy so that each electrode heats the surrounding tissue. During series activation, energy is applied to each electrode one at a time. This sequence of cycling the energy through the electrodes continues at a prescribed frequency and for a period of time.

The electrode systems discussed above are limited by the practical size of lesion volumes they produce. Accordingly, electrodes with cooled conductive tips have been proposed. With cooling, radiofrequency electrode tips generally produce larger lesion volumes compared with radiofrequency electrodes, which are not cooled. For example, standard

single cylindrical electrodes, with cooled tips, as described above, may make lesion volumes up to 2 to 3 cm in diameter in living tissue (e.g., the liver) by using needles of 1 to 2 mm in diameter and having exposed tip lengths of several centimeters.

### SUMMARY

The present disclosure relates to thermal feedback systems for electrosurgical energy systems and methods of their use.

According to an aspect of the present disclosure, a system for providing feedback during an electrosurgical procedure on a target tissue is provided. The system includes an electrosurgical energy source; an electrode probe assembly connected to the electrosurgical energy source, wherein the electrode probe assembly includes at least one electrode assembly having a needle configured to deliver electrosurgical energy to the target tissue; at least one thermal feedback assembly connected to the electrosurgical energy source, wherein each thermal feedback assembly includes at least one temperature sensor assembly; and a hub configured to selectively support the electrode probe assembly and each thermal feedback assembly such that the needle of the electrode probe assembly and each temperature sensor assembly of each thermal feedback assembly are proximate one another when disposed proximate the target tissue.

The needle of the electrode probe assembly may include an electrically conductive distal tip electrically connected to the electrosurgical energy source.

The electrode probe assembly may be fluidly connected to a coolant supply and may be configured to receive a circulating fluid therein.

The thermal feedback assembly may include a one or more temperature sensors. Each temperature sensor may be oriented substantially parallel to an axis defined by the needle of the electrode probe assembly or protrude 90 degrees from the center exposed active electrode. The plurality of temperature sensors may be arranged in a linear array. The plurality of temperature sensors may be disposed on opposed sides of the needle of the electrode probe assembly. The plurality of temperature sensors may be uniformly spaced from one another. The plurality of temperature sensors may be arranged in one of a linear, rectilinear and a triangular array.

The system may further include a computer connected to at least one of the electrosurgical energy source, the electrode probe assembly and each thermal feedback assembly. In an embodiment, at least one of the electrosurgical or microwave generator, the electrode probe assembly and each thermal feedback assembly may transmit information to the computer, and wherein the computer performs an Arrhenius model calculation on the information received from the at least one of the electrosurgical energy source, the electrode probe assembly and each thermal feedback assembly.

The temperature sensors may include fiber optic temperature probes, thermistors, thermocouples or resistive temperature devices (RTD).

According to another aspect of the present disclosure, a method of performing a thermal treatment on a target tissue is provided. The method comprises the steps of providing an electrosurgical energy source; and providing a thermal feedback system. The thermal feedback system includes an electrode probe assembly connectable to the electrosurgical generator, wherein the electrode probe assembly includes at least one electrode assembly having a needle configured to deliver electrosurgical energy to the target tissue; at least one thermal feedback assembly connectable to the electrosurgical energy source, wherein each thermal feedback assembly includes at

least one temperature sensor assembly; and a hub configured to selectively support the electrode probe assembly and each thermal feedback assembly such that the needle of the electrode probe assembly and each temperature sensor assembly of each thermal feedback assembly are proximate one another when disposed proximate the target tissue.

The method further includes the steps of inserting the needle of the electrode probe assembly and each temperature sensor of the thermal feedback assembly into a patient proximate the target tissue; activating the electrosurgical energy source for delivering electrosurgical energy to the target tissue via the needle of the electrode probe; and monitoring and transmitting changes in a characteristic of the target tissue to the electrosurgical energy source via the temperature sensors of the thermal feedback assembly.

The method may further include the step of performing an Arrhenius model calculation on the information received from each thermal feedback assembly.

The method may further include the step of selecting a particular electrode probe assembly for a particular thermal procedure or desired treatment size or volume. Size estimation may be accomplished prior to delivery of the electrode probe assembly. The method may further include the step of selecting a characteristic energy value to be delivered to the particular electrode probe assembly based on the characteristics of the electrode probe assembly and the characteristics of the target tissue to be treated.

The method may further include the step of providing feedback to the electrosurgical energy source from the plurality of thermal feedback probes. Size estimation may be conducted during energy activation.

The method may further include the step of providing a computer configured to receive information regarding characteristics of at least one of the target tissue, the feedback of energy delivery, the electrode probe assembly, the thermal feedback assembly and the electrosurgical energy source. The computer may be configured to receive feedback information from the thermal feedback assembly during a thermal treatment of the target tissue. The computer may be configured to perform an Arrhenius model calculation or other ablation size estimation on the information received from each thermal feedback assembly.

The method may further include the step of arranging the electrode probe assembly and each thermal feedback assembly in a linear array.

The method may further include the step of spacing the thermal feedback assemblies equally from each other and from the electrode probe assembly.

The method may further include the step of spacing the thermal feedback assemblies at a known or predetermined spacing.

The method may further include the step of circulating a fluid through the electrode probe assembly.

The method may further include the step of introducing the electrode probe assembly and each of the plurality of thermal feedback assemblies into the target tissue.

These and other aspects and advantages of the disclosure will become apparent from the following detailed description and the accompanying drawings, which illustrate by way of example the features of the disclosure.

#### BRIEF DESCRIPTION OF THE DRAWINGS

The features of the system and method of use of the system of the present disclosure will become more readily apparent and may be better understood by referring to the following

detailed descriptions of illustrative embodiments of the present disclosure, taken in conjunction with the accompanying drawings, wherein:

FIG. 1 is a schematic illustration of a thermal feedback system illustrating an electrode probe assembly and a thermal feedback assembly of the present disclosure operatively associated with a target surgical site;

FIG. 2 is an illustration of the thermal feedback system of FIG. 1;

FIG. 2A is a schematic distal end view of the thermal feedback system of FIG. 2, illustrating the temperature array in a linear arrangement;

FIG. 2B is a schematic distal end view of an alternate arrangement of the thermal feedback system of FIG. 2, illustrating the temperature array in a rectangular arrangement;

FIG. 2C is a schematic distal end view of a further alternate arrangement of the thermal feedback system of FIG. 2, illustrating the temperature array in a triangular arrangement;

FIG. 2D is a schematic distal end view of the thermal feedback system of FIG. 2, illustrating the temperature array in an alternate linear arrangement;

FIG. 3 is an illustration of a feedback/monitoring assembly of the thermal feedback system;

FIG. 4 is an enlarged view of the indicated area of detail of FIG. 3;

FIG. 5 is a schematic illustration of a distal end of an electrode probe assembly according to a further embodiment of the present disclosure;

FIG. 6 is a distal end view of an electrode probe assembly similar to the electrode probe assembly of FIG. 5;

FIG. 7A is a schematic illustration of a distal end of an electrode probe according to an embodiment of the present disclosure; and

FIG. 7B is a distal, elevational view of the electrode probe of FIG. 7A.

#### DETAILED DESCRIPTION OF EMBODIMENTS

The systems and methods of the present disclosure provide for a more precise controlled monitoring and/or feedback of an electrode probe during therapeutic use in a target surgical site, e.g., in a cancer tumor. Moreover, the systems and methods of the present disclosure provide for an improved ability to predict and/or estimate the depth and/or volume of treatment possible by the electrode probe when the electrode probe of an electrosurgical treatment device is set to a particular or various operative parameters.

It will be readily apparent to a person skilled in the art that the systems and methods of use of the systems can be used to monitor or provide feedback during treatment of body tissues in any body cavity or tissue locations that are accessible by percutaneous or endoscopic catheters or open surgical techniques, and is not limited to cancer tumors or the like. Application of the systems and methods in any corporal organ and/or tissue is intended to be included within the scope of the present disclosure.

##### 1. System for Thermal Feedback

In the drawings and in the description which follows, the term "proximal", as is traditional, will refer to the end of the system, or component thereof, which is closest to the operator, and the term "distal" will refer to the end of the system, or component thereof, which is more remote from the operator.

With reference to FIG. 1, a thermal feedback system, according to an embodiment of the present disclosure, is generally designated as **100**. Feedback system **100** includes a

thermal feedback assembly 200 operatively connected to an electrosurgical generator and/or energy source 10 and/or computer 20.

At least one electrode probe assembly 300 is provided which is operatively associated with feedback assembly 200 and is connectable to electrosurgical energy source 10 in order to perform tissue ablation and the like. Each electrode probe assembly 300 may include a rigid shaft, antenna or needle 310 configured for insertion into a target tissue or organ "OR". Needle 310 of each probe assembly 300 may terminate in an exposed distal tip 312 having a pointed configuration for facilitating percutaneous insertion of needle 310 into body organ "OR". A portion of the external surface of needle 310 of each electrode probe assembly 300 is covered with an insulating material, as indicated by hatched line areas in FIG. 1. Distal tip 312 remains uncovered and is connected, through needle 310, to cable 12 and thereby to electrosurgical energy source 10. Electrode probe assembly 300 may include a coolant supply 30 fluidly connected to needle 310 for circulating a fluid thereto via conduit(s) 32.

Reference may be made to commonly assigned U.S. application Ser. No. 11/495,033, filed on Jul. 28, 2006, and entitled "COOL-TIP THERMOCOUPLE INCLUDING TWO-PIECE HUB" for a detailed discussion of the construction and operation of electrode probe assembly 300.

Temperatures at, or near the exposed distal tip(s) 312 of needle(s) 310 may be controlled by adjusting a flow of fluid coolant through needle 310. Accordingly, the temperature of the tissue contacting at or near distal tip(s) 312 is controlled. In operation, fluid from coolant supply 30 is carried the length of needle 310 through an inner tube (not shown) extending therethrough to the distal end of needle 310 terminating in an open end or cavity (not shown) of distal tip 312. At the opposite end of needle 310, the inner tube is connected to receive fluid. Backflow from distal tip(s) 312 is through an exit port (not shown) of needle 310.

Feedback system 100 may further include a reference electrode 40 that may be placed in contact with the skin of a patient or an external surface of organ "OR" with a connection 42 to electrosurgical energy source 10. Reference electrode 40 and connection 42 serve as a path for return current from electrosurgical energy source 10 through needle 310 of electrode probe assembly 300.

As seen in FIG. 1, by way of illustration only, a targeted region to be ablated is represented in sectional view by the line "T". It is desired to ablate the targeted region "T" by fully engulfing targeted region "T" in a volume of lethal heat elevation. The targeted region "T" may be, for example, a tumor which has been detected by an image scanner 50. For example, CT, MRI, fluoroscopy or ultrasonic image scanners may be used, and the image data transferred to computer 20. As an alternate example, an ultrasonic scanner head 52 may be disposed in contact with organ "OR" to provide an image illustrated by lines 52a.

For example, in FIG. 1, dashed line "T1" represents the ablation isotherm in a sectional view through organ "OR". Such an ablation isotherm may be that of the surface achieving possible temperatures of approximately 50° C. or greater. At that temperature range, sustained for approximately 30 seconds to approximately several minutes, tissue cells will be ablated. The shape and size of the ablation volume, as illustrated by dashed line "T1", may accordingly be controlled by a configuration of the electrode probe assemblies 300 used, the geometry of distal tips 312 of electrode probe assemblies 300, the amount of RF power applied, the time duration that the power is applied, the cooling of the needles 310 of electrode probe assemblies 300, etc.

Data processors may be connected to display devices to visualize targeted region "T" and/or ablation volume "T1" in real time during the ablation procedure.

As seen in FIG. 1, feedback system 100 may further include a library 60 including a plurality of thermal profiles/overlays 62<sub>n</sub>. As used herein, the term library is understood to include and is not limited to repository, databank, database, cache, storage unit and the like. Each overlay 62 includes a thermal profile which is characteristic of and/or specific to a particular configuration of cannula/electrode assembly or amount of exposure (i.e., specific to the length of exposure of distal tip 312 of needle 310 or the amount of needle 310 extending from a distal tip of a cannula) of the cannula/electrode assembly. In addition, for each amount of exposure or configuration of the cannula/electrode assembly, a plurality of overlays 62<sub>n</sub> is provided which includes a thermal profile which relates to, for example, the amount of time electrode probe assembly 300 is activated, to the temperature to which electrode probe assembly 300 is heated, etc.

With continued reference to FIG. 1, feedback system 100, as mentioned above, includes a thermal feedback assembly 200 operatively connected to an electrosurgical generator 10 and/or computer 20. Thermal feedback assembly 200 is operatively associated with the at least one electrode probe assembly 300.

As seen in FIG. 1, feedback assembly 200 includes a hub or housing 210 configured to selectively support at least one electrode probe assembly 300 and at least one temperature sensor assembly 220. As seen in FIG. 1, a plurality of temperature sensor assemblies 220 are shown supported in housing 210 on opposed sides of a single electrode probe assembly 300. It is contemplated that any number of temperature sensor assemblies 220 may be disposed on a single side, on opposed sides, or on multiple sides of the single electrode probe assembly 300 or relative to multiple electrode probe assemblies 300. It is further contemplated that multiple temperature sensor assemblies 220 may be interspersed amongst multiple electrode probe assemblies 300. Individual needles, cannula or introducers 223 may be used to introduce temperature sensors 222 into the target site or organ "OR".

As seen in FIG. 2, housing 210 is used to position temperature sensor assemblies 220 on opposed sides of a single electrode probe assembly 300 so as to define a single axis or plane. Housing 210 may be configured to position cannula 223 and temperature sensors 222 of temperature sensor assemblies 220 at a known distance from electrode probe assembly 300 and/or from one another, or are equi-distant or uniformly spaced from one another.

As seen in FIG. 2A, temperature sensors 222 and electrode assembly 310 are arranged in a linear array. As seen in FIG. 2B, temperature sensors 222 and electrode assembly 310 may be arranged in a rectilinear array. As seen in FIG. 2C, temperature sensors 222 and electrode assembly 310 may be arranged in a triangular array. As seen in FIG. 2D, temperature sensors 222 are arranged at a known distance from electrode assembly 310. As seen in FIGS. 2-2D, electrode assembly 310 is located at the center of temperature sensors 222; however, electrode assembly 310 may be located at any position relative to sensors 222.

Each temperature sensor assembly 220 is electrically or optically connected to electrosurgical generator 10 via a suitable electrical connector or the like 230.

Temperature sensors 222 include one or more of an emitter, sensor or marker to provide special relationship to electrode assembly 310. Each temperature sensor assembly 220 may include a temperature sensor 222 in the form of a rigid or semi-rigid cannula 223 and/or needles configured for inser-

tion and/or penetration into the target surgical site. Suitable temperature sensors 222 may include thermocouples, resistive temperature devices (RTD) or fiber optic temperature probes sold under the tradename "Fluoroptic® Thermometer, available from Luxtron®, Santa Clara, Calif. Temperature sensors 222 are shown and described in U.S. Pat. Nos. 4,075, 497; 4,215,275; 4,448,547; 4,560,286; 4,752,141; 4,883,354; and 4,988,212.

Fluoroptic® temperature sensors 222 are configured to measure the decay time of light emitted from phosphorescent materials (e.g., phosphors). The decay time is a persistent property of the sensor that varies directly with the temperature.

Other suitable temperature sensors for use with temperature sensor assemblies 220, to measure the temperature at a target surgical site, include and are not limited to optical sensors (e.g., Fluoroptic®, infrared, etc.), thermocouples, Resistance-Temperature-Detectors (RTD), thermistors, MRI, fluoroscopic, ultrasound, CT and the like.

Temperature sensors 222 may be configured to measure or monitor temperatures greater than about 60° C. In an embodiment, feedback system 100 may be provided with suitable algorithms or the like for interpolating temperature values from at least two temperature sensors 222 and/or for integrating thermal damage from at least two temperature sensors 222. One real-time temperature sensor may be used in conjunction with an assumed or predetermined value from a look-up table or similar method.

The temperature measurements delivered to feedback system 100 may be used to generate a thermal map of the target area and/or, upon integration, may be used to account for particular tissue characteristics, such as, for example, perfusion, conduction, resistance and/or density.

In an embodiment, temperature sensors 222 may be deployed around needle 310 of the electrode probe assembly 300. Such temperature sensors may be constructed of suitable shape memory alloys so as to permit the temperature sensor to wrap around needle 310. Additionally, in an embodiment, a cannula including temperature sensors may be deployed about needle 310 of the electrode probe assembly 300. In another embodiment, as seen in FIGS. 7A and 7B, temperature sensors 222 may protrude at a substantially right angle from a center or mid point of the exposed distal tip 312 of needle 310.

Electrosurgical generator 10 and electrode probe assembly 300 may be configured to deliver energy to at least one of a radiofrequency, a microwave, an ultrasound, and a cryotherapy needle.

Feedback system 100 is capable of providing size predictability for ablation volume to be created during a thermal procedure of a target region prior to the ablation volume exceeding a predetermined volume during the thermal procedure. For example, feedback system 100 may provide feedback regarding a volume of the thermal therapy (e.g., diameter), and estimation of an overall size of the volume of the thermal therapy, an estimation of a rate of growth of the volume of the thermal therapy, and/or an estimation of a time to completion of the thermal therapy. All of this information may be displayed on a monitor 54 (See FIG. 1) or the like. Additionally, monitor 54 may illustrate the growth of the ablation volume, in real-time, as the procedure is going forward.

As seen in FIGS. 5-7, a distal end of electrode probe assemblies according to further embodiments of the present disclosure are generally designated as 300' and 300", respectively. Electrode probe assembly 300', 300" is substantially similar to electrode probe assembly 300 and thus will only be dis-

cussed in further detail herein to the extent necessary to identify differences in construction and operation thereof.

As seen in FIGS. 5 and 7, distal tip 312' of electrode probe assembly 300' has a length of exposure "L". Additionally, electrode probe assembly 300' is configured such that temperature sensor 222' extends radially outward therefrom at a location approximately equal to "L/2". As seen in FIG. 5, temperature sensor 222' may extend radially and linearly from electrode probe assembly 300' (e.g., in a plane that is substantially orthogonal to a longitudinal axis of electrode probe assembly 300'), or, as seen in FIG. 6, temperature sensor 222" may extend radially and arcuately from electrode assembly 300" (e.g., in a plane that is substantially orthogonal to a longitudinal axis of electrode probe assembly 300").

As seen in FIG. 5, a single temperature sensor 222' may extend from electrode assembly 300', and as seen in FIG. 6, a pair of temperature sensors 222" may extend from electrode assembly 300". In any of the embodiments disclosed herein, any number of temperature sensors 222' or 222" may be used to extend from electrode assembly 300', 300" or 300'.

Each temperature sensor 222' or 222" may include at least one, and as seen in FIGS. 5 and 6, a plurality of discrete respective temperature sensor elements 222a', 222a" disposed along a length thereof, such as, for example, at least at a tip thereof, at a mid-point thereof and at a base or proximal end thereof.

As seen in FIGS. 5 and 6, each temperature sensor 222' or 222" may be slidably disposed within a respective electrode probe assembly 300', 300" and configured so as to project and/or retract from within electrode probe assembly 300' or 300". Each temperature sensor 222', 222" may extend along an outer surface of a respective electrode probe assembly 300', 300".

Each temperature sensor 222', 222" may be deployable to a known and/or predetermined radial distance from respective distal tips 312', 312" of respective electrode probe assembly 310', 310". In accordance with FIG. 6, or in embodiments employing multiple temperature sensors 222", the multiple temperature sensors 222" may be deployed to a known and/or predetermined distance from one another.

As seen in FIG. 7, temperature sensors 222" may be disposed to a known and/or predetermined radial distance from electrode probe assembly 300". Temperature sensors 222" are generally disposed L/2 and 1/2 desired diameter of thermal ablation (W/2), wherein "L" is the length of exposure of the distal end of electrode probe assembly 300" and "W" is the approximate diameter of the thermal ablation.

## 2. Method for Thermal Feedback

With reference to FIGS. 1-7B, a method of using thermal feedback system 100 during the thermal treatment of a target tissue or organ "OR" with electrode probe assembly 300, 300' or 300", in conjunction with hyperthermia feedback assembly 200, is described.

A method of the present disclosure includes determining a zone of thermal treatment during and/or post treatment of the target tissue or organ "OR". The method may comprise the step of measuring a temperature of the target tissue or organ "OR", at known distances relative thereto, during and/or post treatment of the target tissue or organ "OR". The temperature of the target tissue or organ "OR", at the known distance, may be an absolute temperature and/or a temperature that is interpolated. Additionally, the method may comprise integrating the temperature over time to determine an extent of thermal treatment. Such an integration may be calculated using an "Arrhenius thermal treatment integral" or other methods of thermal damage estimation.

As used herein, "thermal damage" is a term that describes a quantity representing a relative amount of destruction to a tissue component. The component of interest can vary widely between applications from sub-cellular components, such as, for example, protein or organelles, to many celled systems, such as, for example, tumors or organs. To study systems spanning such a wide range of scale different techniques may be applied. For a relatively small system, one approach may be an "ab initio" method or some other molecular dynamic approach. For relatively larger systems, one approach may be to use an empirical method, such as, for example, the "Arrhenius" method described herein or a critical temperature criterion.

The term "Arrhenius thermal treatment" refers to a method of quantifying thermal effects on underlying tissue. The present method thus models microscopic effects in tissue, such as, for example, the denaturation of a single species of protein, or models macroscopic effects in tissue, such as, for example, a color change of the tissue associated with the thermal treatment where many different reactions have taken place.

The equation for the "Arrhenius model" may be represented by the following equation:

$$\Omega(t) = -\ln\left(\frac{c(t)}{c(0)}\right) = A \int_0^t e^{\left(\frac{-\Delta E}{RT}\right)} dt$$

where:

$\Omega$ =is the thermal effect sustained by the tissue or organ;

$c(t)$ =is the amount of the component of interest remaining;

$c(0)$ =is the amount of the component of interest at time zero;

$A$ =is the frequency factor, approximately  $7.39 \times 10^{39}$  /s (specific to liver tissue); and

$\Delta E$ =is the activation energy, approximately  $2.577 \times 10^5$  J/mol (specific to liver tissue).

The "Arrhenius model" is used because, in addition to combined processes, the "Arrhenius model" applies to individual processes as well. Individual processes that may be of interest include and are not limited to the denaturation of a lipid bi-layer of a cell, the denaturation of mitochondrial proteins, and the denaturation of nuclear proteins. The denaturation of lipid bi-layer is of interest because the lipid bi-layer loses its structure before many other parts of a cell. The denaturation of mitochondrial and nuclear proteins is of interest because they denature at temperatures in the range of about 42 to 60° C.

A method of the present disclosure may also include the step of using a position of electrode probe assembly 300, 300' or 300" and needle 310, positional temperature and/or feedback temperature received from hyperthermia feedback assembly 200 to determine the extent of thermal effect or treatment to the target tissue or organ "OR". The position of electrode probe assembly 300, 300' or 300" and needle 310 may be determined using a suitable positional indicator. The positional temperature may be determined by the location of temperature sensor 222, 222', 222" or 222'" and may be used to determine the presence of the lack of heat in the tissue or organ "OR".

A method of the present disclosure may also include the step of determining the spatial relationship between electrode probe assembly 300 and temperature sensor 222. Spatial relationship of electrode probe assembly 300 and temperature sensor 222 and temperature measured at temperature sensor 222 are feedback to computer 20 to determine an extent of

thermal damage that may be displayed on monitor 54 or used to alter the output of electrosurgical energy source 10.

A method of the present disclosure may use a three-dimensional (3D) thermal image/map to determine a dimension of thermal treatment of the target tissue of organ "OR".

According to a method of the present disclosure, computer 20 of feedback system 100 is provided with information regarding a location of the target tissue or organ "OR", a location of critical biological structures (e.g., tissue, organs, vessels, etc.), a size and/or shape of the tumor or the target tissue or organ "OR" to be thermally treated, and a desired size of the thermal treatment volume. With this information inputted into computer 20, computer 20 may apply the "Arrhenius model" in order to develop a course of treatment.

According to a method of the present disclosure, an electrode probe assembly 300, 300' or 300" including a particular needle 310 having a given length "L" of exposure of distal tip 312 thereof is selected for a particular thermal procedure. A length "L" of electrode exposure may be user selected based on a desired volume of tissue to be treated or diameter "W" of thermal treatment. With the particular electrode probe assembly 300, 300' or 300" selected the parameters (e.g., dimensions, power rating, etc.) of electrode probe assembly 300, 300' or 300" is manually inputted or automatically selected from a look-up table for use by the electrosurgical generator 10 and/or computer 20.

With the parameters or characteristics of the tumor, target tissue or organ "OR" inputted into the electrosurgical energy source 10 and/or computer 20 and the parameters or characteristics of the electrode probe assembly 300, 300' or 300" selected also inputted into the electrosurgical generator 10 and/or computer 20, the parameters of the energy to be delivered to the tumor, target tissue or organ "OR", via the electrode probe assembly 300, 300' or 300", are determined. As seen in FIG. 1, with the parameters of the energy to be delivered determined, thermal feedback assembly 200 and with electrode probe assembly 300 inserted into the patient, proximate the tumor, target tissue or organ "OR". In particular, temperature sensors 222 of thermal feedback assembly 200 and needle 310 of electrode probe assembly 300 may be inserted into the tumor, target tissue or organ "OR".

With thermal feedback assembly 200 and electrode probe assembly 300 positioned, the placement of thermal feedback assembly 200 and electrode probe assembly 300 is confirmed. Next, a spatial relationship of temperature sensors 222 and electrode probe assembly 300 may be determined by using thermal feedback assembly 200 or use of other markers, and communicated to electrosurgical energy source 10 and/or computer 20 for use of feedback control of energy parameter and/or size estimation. After confirmation of the placement of thermal feedback assembly 200 and electrode probe assembly 300 the thermal treatment of the tumor, target tissue or organ "OR" may begin. The thermal treatment of the tumor, target tissue or organ "OR" includes delivering energy produced by electrosurgical generator 10 to the tumor, target tissue or organ "OR" via electrode probe assembly 300.

During the thermal treatment of the tumor, target tissue or organ "OR" hyperthermia feedback assembly 200 provides feedback to electrosurgical energy source 10 and/or computer 20 in the manner described above. Treatment progress is determined by computer 20 with feedback from at least one of image scanner 5, electrosurgical energy source 10, and temperature sensors 222. Treatment progress is displayed on monitor 54. Treatment progress includes one of size estimation, rate of treatment progression, and relationship of treatment volume to target volume.

While the above description contains many specific examples, these specific should not be construed as limitations on the scope of the disclosure, but merely as exemplifications of preferred embodiments thereof. Those skilled in the art will envision many other possible variations that are within the scope and spirit of the disclosure as defined by the claims appended hereto.

What is claimed is:

1. A method for treating tissue, comprising:  
 inserting an electrode probe assembly and at least one thermal feedback assembly into tissue, the electrode probe assembly and the at least one thermal feedback assembly being disposed in a hub;  
 activating an electrosurgical generator coupled to the electrode probe assembly and the at least one thermal feedback assembly to deliver electrosurgical energy to the tissue through the electrode probe assembly to thermally treat the tissue;  
 measuring a temperature of the tissue at the at least one thermal feedback assembly; and  
 transmitting the measured temperature to the electrosurgical generator.
2. The method according to claim 1, further comprising: controlling delivery of the electrosurgical energy based on the measured temperature.
3. The method for treating tissue according to claim 1, further comprising:  
 estimating a desired thermal treatment volume in response to thermal treatment of the tissue based on the measured temperature.
4. The method for treating tissue according to claim 3, further comprising:  
 generating an image of the tissue at a display; and  
 generating a three-dimensional thermal image representative of the desired thermal treatment volume at the display.
5. The method for treating tissue according to claim 3, further comprising:  
 inputting into the electrosurgical generator a distance between the electrode probe assembly and the at least one thermal feedback assembly.
6. The method for treating tissue according to claim 5, further comprising:  
 inputting into the electrosurgical generator at least one property of the electrode probe assembly.
7. The method for treating tissue according to claim 6, wherein the at least one property of the electrode probe assembly is a length of a treatment portion of the electrode probe assembly.
8. The method for treating tissue according to claim 6, further comprising:  
 inputting into the electrosurgical generator at least one property of the tissue.
9. The method for treating tissue according to claim 8, wherein the desired thermal treatment volume is estimated based on at least one of the distance between the electrode probe assembly and the at least one thermal feedback assembly, the measured temperature, the at least one property of the electrode probe assembly, or the at least one property of the tissue.

10. The method for treating tissue according to claim 9, wherein the desired thermal treatment volume is estimated based on an Arrhenius model.

11. The method for treating tissue according to claim 3, wherein estimating the desired thermal treatment volume includes estimating at least one of size, rate of treatment progression, and difference between the desired thermal treatment volume and an actual thermal treatment volume.

12. The method for treating tissue according to claim 1, wherein insertion of the electrode probe assembly further includes inserting a plurality of thermal feedback assemblies into tissue, the plurality of thermal feedback assemblies being disposed in the hub symmetrically about the electrode probe assembly.

13. A method for treating tissue, comprising:  
 inserting an electrode probe assembly and a plurality of thermal feedback assemblies into tissue, the electrode probe assembly being disposed in a hub and the plurality of thermal feedback assemblies being disposed in the hub symmetrically about the electrode probe assembly;  
 activating an electrosurgical generator coupled to the electrode probe assembly and the plurality of thermal feedback assemblies to deliver electrosurgical energy to the tissue through the electrode probe assembly to thermally treat the tissue;  
 measuring a temperature of the tissue at each of the plurality of thermal feedback assemblies; and  
 transmitting the measured temperature from each of the plurality of thermal feedback assemblies to the electrosurgical generator.

14. The method for treating tissue according to claim 13, further comprising:  
 estimating a desired thermal treatment volume in response to thermal treatment of the tissue based on the measured temperature at each of the plurality of thermal feedback assemblies.

15. The method for treating tissue according to claim 14, further comprising:  
 inputting into the electrosurgical generator a distance between the electrode probe assembly and each of the plurality of thermal feedback assemblies.

16. The method for treating tissue according to claim 15, further comprising:

inputting into the electrosurgical generator at least one property of the electrode probe assembly.

17. The method for treating tissue according to claim 16, further comprising:

inputting into the electrosurgical generator at least one property of the tissue.

18. The method for treating tissue according to claim 17, wherein the desired thermal treatment volume is estimated based on at least one of the distance between the electrode probe assembly and each of the plurality of thermal feedback assemblies, the measured temperature, the at least one property of the electrode probe assembly, or the at least one property of the tissue.

19. The method for treating tissue according to claim 14, wherein estimating the desired thermal treatment volume includes estimating at least one of size, rate of treatment progression, and difference between the desired thermal treatment volume and an actual thermal treatment volume.

专利名称(译)	热反馈系统及其使用方法		
公开(公告)号	<a href="#">US8956350</a>	公开(公告)日	2015-02-17
申请号	US14/066050	申请日	2013-10-29
[标]申请(专利权)人(译)	柯惠有限合伙公司		
申请(专利权)人(译)	COVIDIEN LP		
当前申请(专利权)人(译)	COVIDIEN LP		
[标]发明人	BUYSSE STEVEN P LADTKOW CASEY M GAY BRANDON		
发明人	BUYSSE, STEVEN P. LADTKOW, CASEY M. GAY, BRANDON		
IPC分类号	A61B18/18 A61B5/00 A61B5/01 A61B18/00 A61B18/12 A61B18/14 A61B19/00		
CPC分类号	A61B5/4836 A61B18/1477 A61B5/015 A61B5/743 A61B18/1206 A61B18/18 A61B2018/00702 A61B2018/00791 A61B2018/00797 A61B2018/00815 A61B2018/00821 A61B2019/5236 A61B2019 /5238 A61B2019/524 A61B2019/5276 A61B2090/374 A61B2090/376 A61B2090/3762 A61B2090/378 A61B5/0036 A61B18/1815 A61B2018/00011 A61B2018/1823 A61B2018/183		
优先权	60/887537 2007-01-31 US		
其他公开文献	US20140058384A1		
外部链接	<a href="#">Espacenet</a> <a href="#">USPTO</a>		

#### 摘要(译)

提供了一种用于在电外科手术期间在目标组织上提供反馈的系统。该系统包括电外科能量源;连接到电外科能量源的电极探针组件,其中电极探针组件包括至少一个电极组件,该电极组件具有构造成将电外科能量传递到目标组织的针;至少一个热反馈组件连接到电外科能量源,其中每个热反馈组件包括至少一个温度传感器组件;枢轴,被配置为选择性地支撑电极探针组件和每个热反馈组件,使得当设置在目标组织附近时,电极探针组件的针和每个热反馈组件的每个温度传感器组件彼此接近。

A system for providing feedback during an electrosurgical procedure on a target tissue is provided. The system includes an electrosurgical energy source; an electrode probe assembly connected to the electrosurgical energy source, wherein the electrode probe assembly includes at least one electrode assembly having a needle configured to deliver electrosurgical energy to the target tissue; at least one thermal feedback assembly connected to the electrosurgical energy source, wherein each thermal feedback assembly includes at least one temperature sensor assembly; and a hub configured to selectively support the electrode probe assembly and each thermal feedback assembly such that the needle of the electrode probe assembly and each temperature sensor assembly of each thermal feedback assembly are proximate one another when disposed proximate the target tissue.