



US 20190183380A1

(19) **United States**

(12) **Patent Application Publication**  
**KALANTAR-ZADEH et al.**

(10) **Pub. No.: US 2019/0183380 A1**  
(43) **Pub. Date: Jun. 20, 2019**

(54) **GAS SENSOR CAPSULE**

*A61B 5/1491* (2006.01)

*G01N 33/497* (2006.01)

*A61B 5/145* (2006.01)

(71) Applicant: **ROYAL MELBOURNE INSTITUTE OF TECHNOLOGY**, Melbourne, Victoria (AU)

(52) **U.S. Cl.**

CPC ..... *A61B 5/073* (2013.01); *A61B 5/002*

(2013.01); *A61B 5/1491* (2013.01); *A61B*

*5/4238* (2013.01); *A61B 5/4255* (2013.01);

*A61B 2562/162* (2013.01); *G01N 33/497*

(2013.01); *A61B 5/1451* (2013.01); *A61B*

*5/14539* (2013.01); *A61B 5/14542* (2013.01);

*A61B 2562/0271* (2013.01); *A61B 5/6861*

(2013.01)

(72) Inventors: **Kourosh KALANTAR-ZADEH**, Albert Park, Victoria (AU); **Kyle BEREAN**, Preston, Victoria (AU); **Nam HA**, Maidstone, Victoria (AU); **Jian Zhen OU**, Chadstone, Victoria (AU)

(73) Assignee: **ROYAL MELBOURNE INSTITUTE OF TECHNOLOGY**, Melbourne, Victoria (AU)

(57)

**ABSTRACT**

A capsule adapted to be introduced into the digestive system and gastrointestinal (GI) tract of a mammal which consists of a capsule shaped container consisting of a wall material capable of being bio compatible with the digestive system and being adapted to protect the electronic and sensor devices contained in the capsule. The capsule contains gas composition sensors operable at several temperature points for a short duration, a temperature sensor, a micro controller, a power source and a wireless transmission device. The capsule wall incorporates gas permeable membranes adjacent said gas sensors. The microprocessor is programmed to receive data signals from the sensors and convert the signals into gas composition and concentration data and temperature data suitable for transmission to an external computing device.

(21) Appl. No.: **16/325,272**

(22) PCT Filed: **Aug. 14, 2017**

(86) PCT No.: **PCT/AU2017/000167**

§ 371 (c)(1),

(2) Date: **Feb. 13, 2019**

(30) **Foreign Application Priority Data**

Aug. 15, 2016 (AU) ..... 2016903219

**Publication Classification**

(51) **Int. Cl.**

*A61B 5/07* (2006.01)

*A61B 5/00* (2006.01)

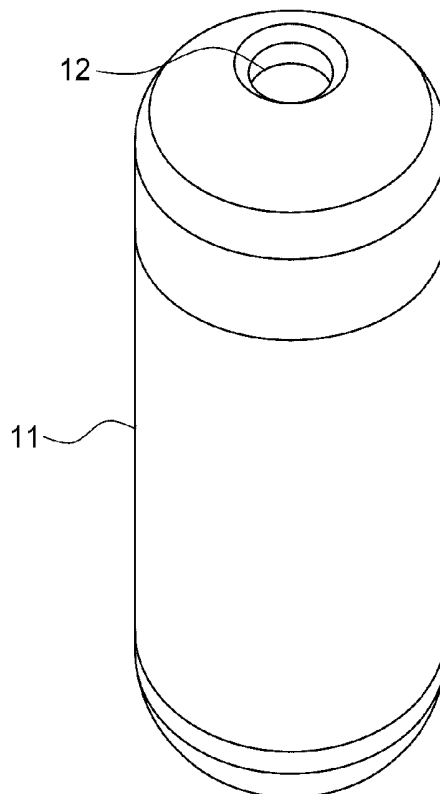

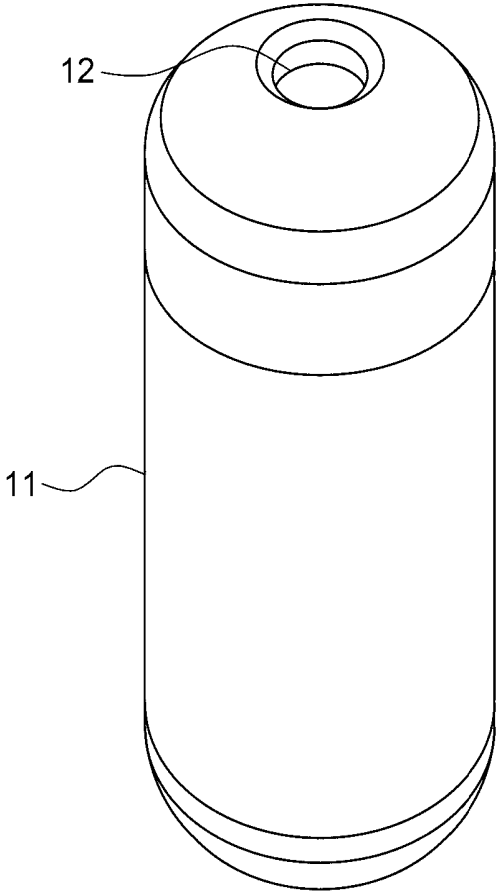

FIG. 1A

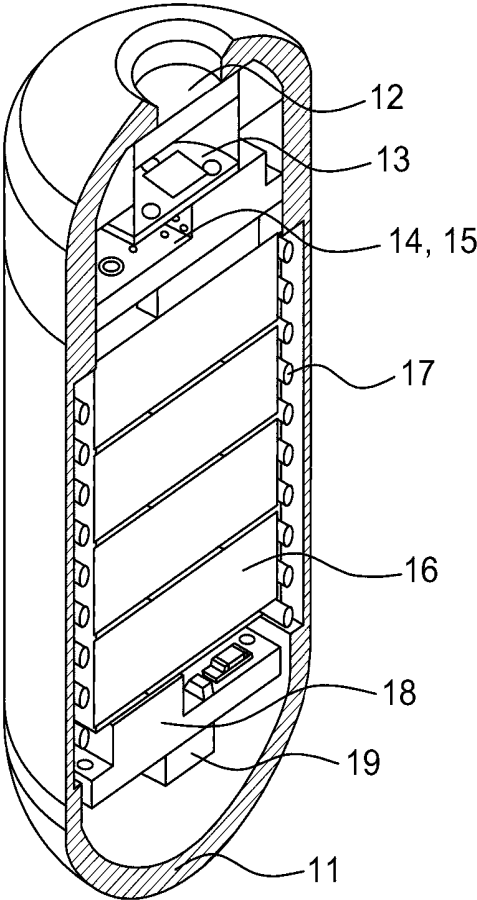

FIG. 1B

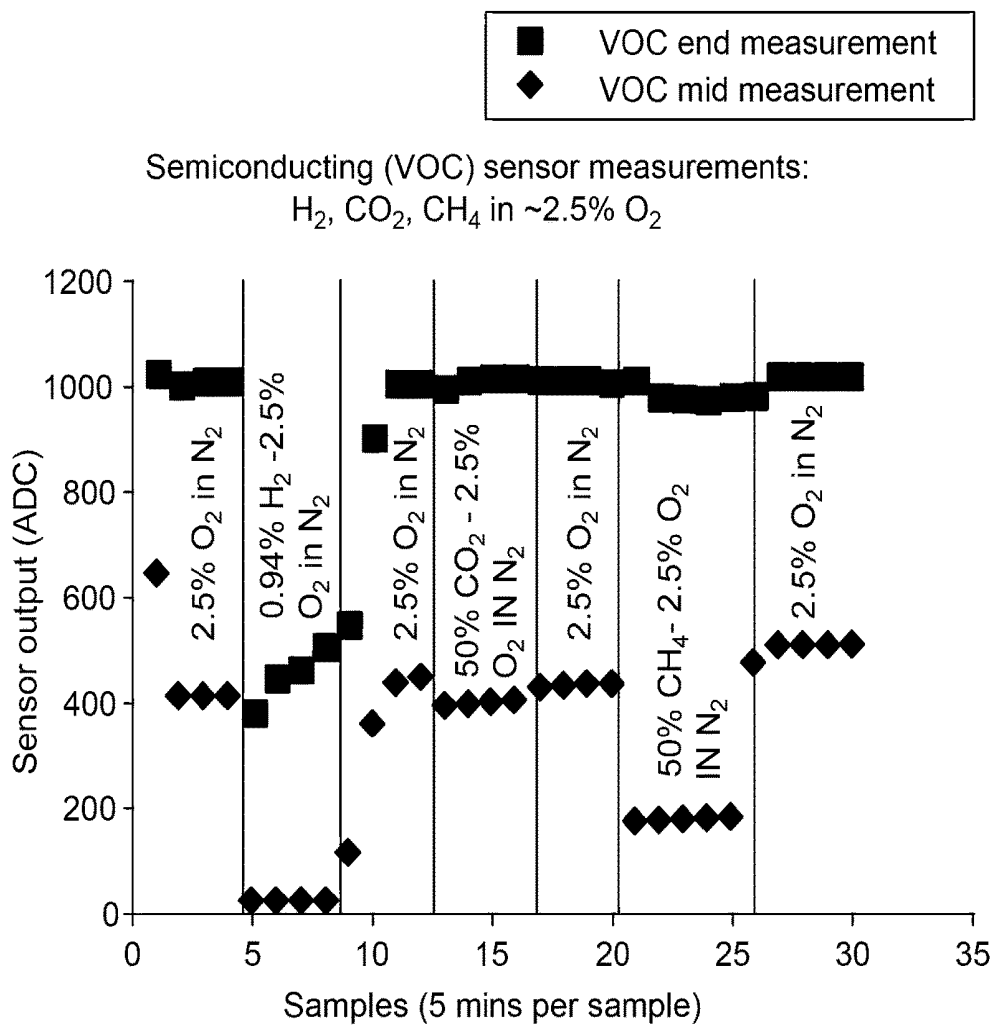

FIG. 2A

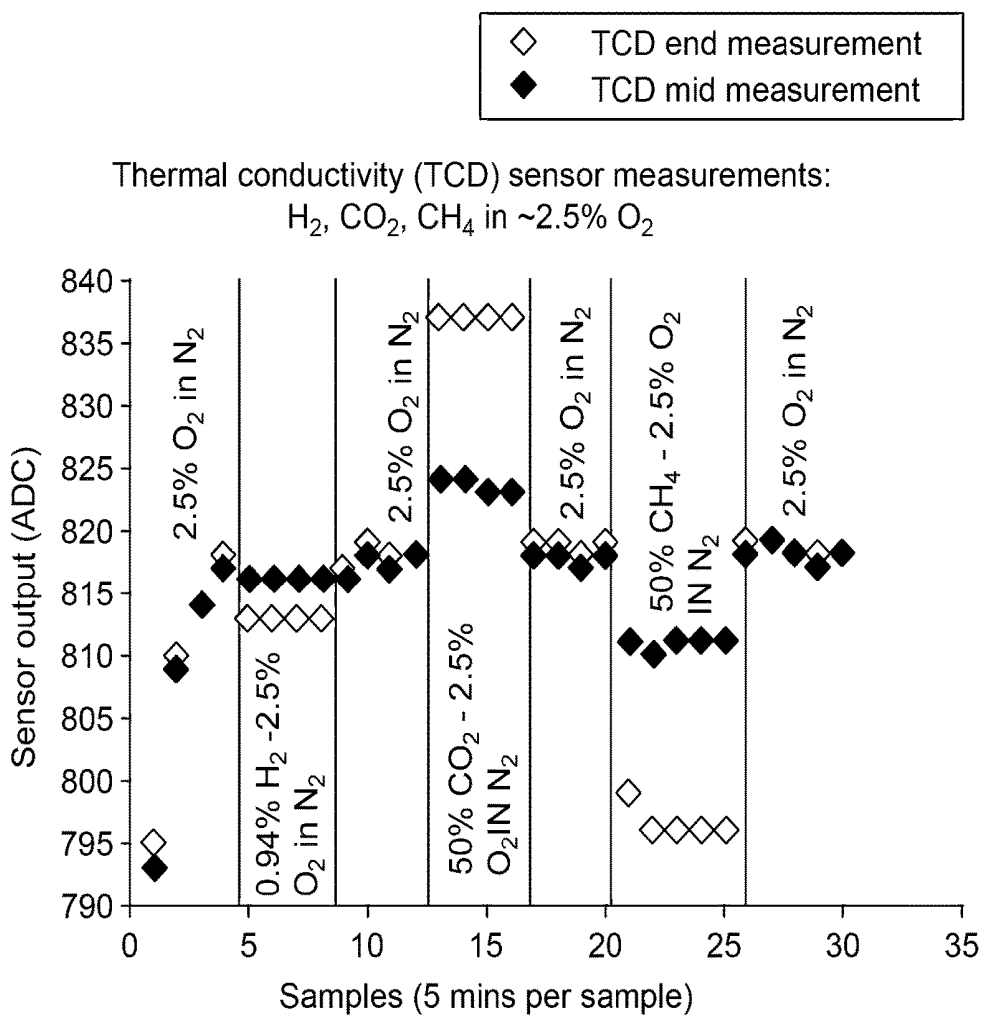

FIG. 2B

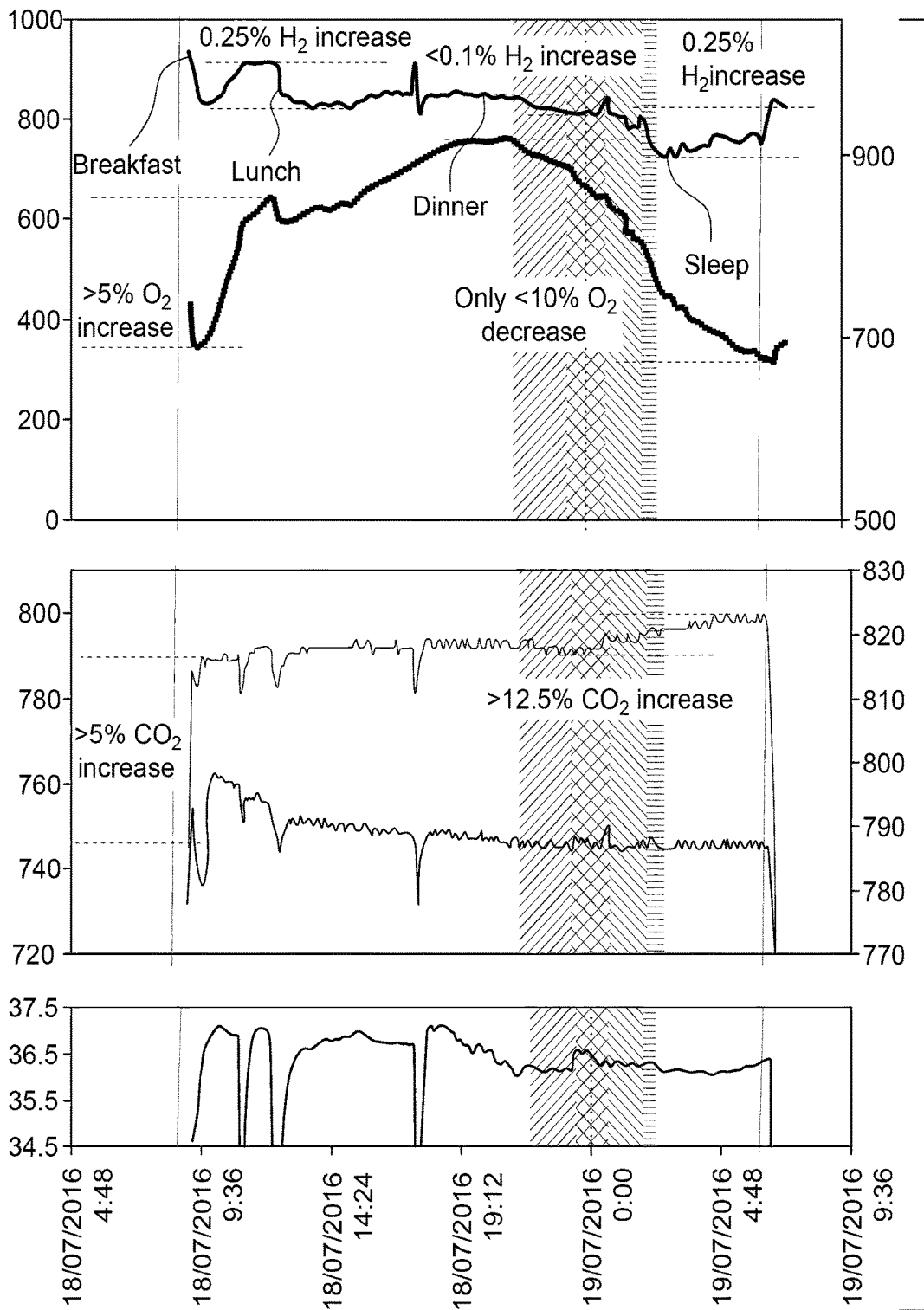

FIG. 3

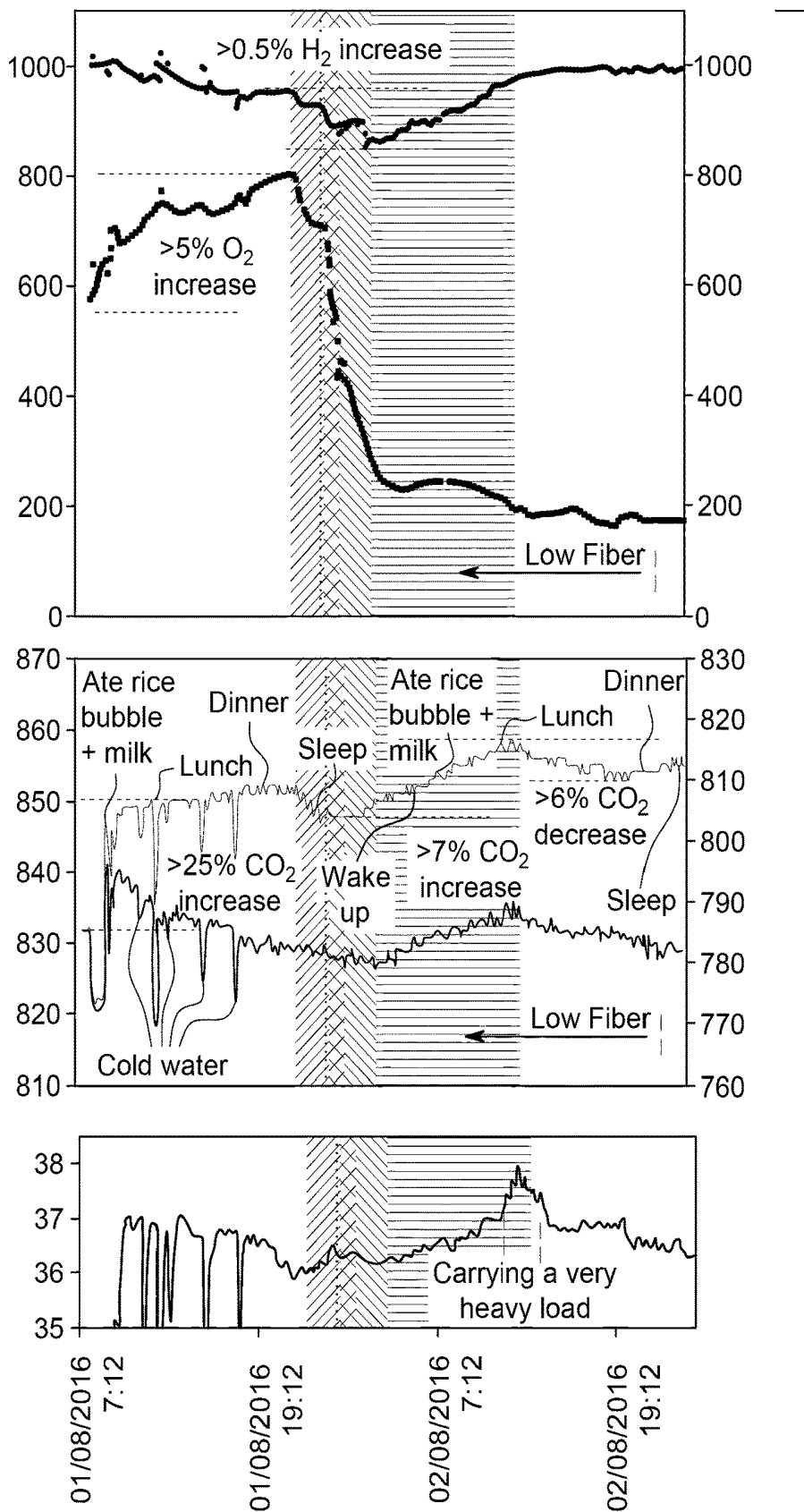

FIG. 4

## GAS SENSOR CAPSULE

[0001] This invention relates to gas sensors useful in an ingestible sensor capsule for monitoring gases generated in the gastrointestinal (GI) tract of mammals including humans.

### BACKGROUND TO THE INVENTION

[0002] While there are currently diagnostic tools available such as capsule endoscopy and breath analysers, there is no equipment for the analysis of the gas constituents in the gastrointestinal tract. There are many reports on the strong likelihood of the association of these gas constituents to different illnesses. However, due to lack of any suitable tool and the inconveniences that these measurements create for the patients, the potential of this area has yet to be fully realized.

[0003] A capsule camera (Pillcam™) is commercially available for visualizing the colon and evaluating polyps. There is also available SmartPill which is an ingestible capsule that measures pH, pressure and temperature during the passage through the gastrointestinal (GI) tract.

[0004] U.S. Pat. No. 8,469,857 discloses a method of diagnosing GI conditions by analysing gases in breath analysis.

[0005] Patent application WO2013/003892 discloses a capsule with gas sensors and a gas permeable membrane for use with ruminant animals.

[0006] Optical gas sensors (generally infrared—IR) are the most gas selective devices even developed and are also used in WO2013/003892 for ruminants. However, the size of such capsules is large and cannot be used for human. There is still no technology for fabricating a small IR based gas sensor that can be used for humans. The smallest pill dimension standard for human is 000 and none of the current optical technologies allow the development of such optical based gas capsules.

[0007] USA patent application 2009/0318783 discloses a computerised method analysing data from the GI tract using an ingestible capsule that contains a sensor and providing data on the measurement plotted against time.

[0008] USA patent application 2013/0289368 discloses an ingestible capsule with a gas detector to assist in diagnosing diseases of the GI tract.

[0009] A difficulty with prior art devices is the lack selectivity of the gas sensors. For instance, a pure PDMS membrane allows all gas species to permeate through. This may be acceptable when highly selective gas sensors are used. However, most available gas sensors are non-selective. For instance the current hydrogen (H<sub>2</sub>) gas sensors are also sensitive to other gas species such as methane (CH<sub>4</sub>). Such lack of specificity seriously compromises the accuracy of the measurements.

[0010] It is an object of this invention to provide gas sensors for a GI tract capsule that can detect multiple gases.

### BRIEF DESCRIPTION OF THE INVENTION

[0011] To this end the present invention provides a gas spectrometer for detecting GI tract gases which includes a semiconductor gas sensor and a thermal conductive gas sensor each operated at different temperatures for a predetermined duration so that they are able to selectively detect oxygen, hydrogen, carbon dioxide and methane; both gas

sensors operating under the control of a microprocessor programmed with software to differentiate between the gases.

[0012] By changing the operating temperature of the gas sensors become more or less sensitive to specific gases of the gut. By changing the heater temperature (changing the duration of heating), the gas sensor can act as a single element that produces different values to various gases depending on the duration of the heating. Each sampled value, at a time, can be considered a pixel for a pseudo spectrometer. This means, if the sensor is sampled twice a spectrum of two pixels is produced. If the sensor element is sampled 100 times, a spectrum of 100 pixels is generated. Each spectrum is more specific for the sensor element. In this invention, the simplest pseudo element, consisting of two pixels per sensor is presented. Semi conducting and thermal conductivity sensors are the base of the invention as they both show gas responses that are a strong and repeatable function of their operating temperatures.

[0013] Another advantage of the semi conductor and thermal conductive based sensors is their very small sizes (in the mm order range). As such, they are the best candidates as gas sensor elements in human gas sensor capsules of less than 000 capsule dimensions.

[0014] Both semiconductor and thermal conductive gas sensors operate under the control of a microprocessor preferably programmed with a pattern recognition software such as neural network software to differentiate between the gases.

[0015] The two gas sensors are preferably contained in one portion of an ingestible capsule sealed from the battery and electronic components. The outer surface of this portion of the capsule is composed of a selectively permeable membrane. The sensor surfaces are located above a micro heater so that the sensors are heated in a short duration of less than a second to two or more different temperatures, depending on the number of pixels to be acquired for each spectrum. The sensitivity to different gases varies according to the temperature and this in association with the neural network software enables the readings from the different data points to be clustered for identification of the gases.

[0016] The capsules include gas permeable membranes to assist in the selectivity of the sensors. These are preferably the membranes disclosed in WO2016033638.

[0017] In another aspect this invention provides a capsule adapted to be introduced into the digestive system and GI tract of a mammal which consists of

[0018] a capsule shaped container consisting of a wall material capable of being bio compatible with the digestive system and being adapted to protect the electronic and sensor devices contained in the capsule;

[0019] said capsule containing the gas spectrometer described above, optionally a temperature sensor, a micro controller, a power source and a wireless transmitter;

[0020] the microprocessor being programmed to receive data signals from the sensors and convert the signals into gas composition and concentration data and temperature data suitable for transmission to an external computing device. Between the data acquisition times, the microcontroller switches of the heater to sensors and goes into sleep mode to save power.

[0021] When the capsule is in the body, a data receiver is kept in close proximity, usually less than 5 metres away, to

continuously collect the data signals from the capsule during the hours in which the capsule passes through the stomach, small intestine and colon.

**[0022]** The gas sensor capsule allows an accurate identification of the target gases in situ, where they are produced, and assists in linking them with more certainty to the state of health, effect of diet, environmental influences and the presence of illnesses.

**[0023]** These capsules permit the whole gastrointestinal tract to be surveyed, not just the accessible parts. In addition, the procedure is non-invasive and capsules pass out of the body of the subjects at the end of the process.

**[0024]** Especially for human applications, after being swallowed, the “gas sensor capsule” will help gastroenterologists to survey human subjects’ gas species and their concentrations in oesophagus, stomach, duodenum, jejunum, and ileum (small intestine), as well as the cecum, colon and rectum (large intestine). The capsule may also help in understanding the gas species produced in other mammals and associate them with their diets, state of health and the volume of gas production (for gas mitigation or production efficiency increase). The device allows the possibility of accurately investigating and fully obtaining the correlations between the existing gas species and gastrointestinal medical illnesses. Establishing such correlations and accurately assessing the gas content of the digestive tract of individual subjects will help to reveal the effects of the existing microorganisms in the digestive tract and help prescribing correct medications, resulting in more accurate targeting of gastrointestinal illnesses. As such, the gas sensor capsule will be an invaluable tool for assessing health status, using non-invasive diagnostics.

**[0025]** The gas sensor capsule of this invention is a diagnostic and monitoring tool, which may be swallowed and has the capability of accurately sampling gas constituents throughout the entire gastrointestinal tract. Its advantages are high selectivity and sensitivity measurements of gas constituents along the tract.

#### DETAILED DESCRIPTION OF THE INVENTION

**[0026]** Preferred embodiments of the invention will be described with reference to the drawings in which:

**[0027]** FIG. 1A is a schematic of a preferred capsule of this invention;

**[0028]** FIG. 1B is a cross sectional view of the preferred capsule;

**[0029]** FIGS. 2A and B show response of two sensors to some typical gases of the gut for calibration;

**[0030]** FIG. 3 is the graphical output of data points from the two gas sensors over time, of a body response to a high fibre diet;

**[0031]** FIG. 4 is a graphical output from the two sensors of a body response to a low fibre diet.

**[0032]** The main components of a preferred capsule are illustrated in FIG. 1.

**[0033]** As shown in FIGS. 1 A and B the typical capsule consists of a gas impermeable shell **11** which has an opening covered by a gas permeable membrane **12**.

**[0034]** Internally the capsule includes a gas sensor **13**, a temperature sensor **14**, micro controller **15**. The electronics also includes silver oxide batteries **16**, an antenna **17**, a wireless transmitter **18** and a reed switch **19**.

**[0035]** The main components of the capsule are:

**[0036]** Sensors **13**: The two gas sensors are less than several mm in dimension each and are used to detect oxygen, hydrogen, carbon dioxide and methane. The anaerobic sensor is thermal conductor sensor and the aerobic sensor is a semiconductor sensor. The two gas sensors are contained in one portion of the capsule sealed from the battery and electronic components. The outer surface of this portion of the capsule is composed of a selectively permeable membrane. The sensor surfaces are located above a micro heater so that the sensors are heated in a short duration of less than a second to two or three different temperatures (the heating duration for the graph examples are shown in FIGS. 2A and 2B). The sensors are pre-calibrated, so that a sensor reading can be used to identify the composition and concentration of a particular gas. The sensitivity to different gases vary according to the operational temperature and this in association with the neural network or another pattern recognition software enables the readings from the different data points to be clustered for identification of the gases. As can be seen in FIG. 2 the sensors can show small cross-talks in sensing the gases. The increase in the number of sensors will help in extracting the exact response to each target gas using mathematical algorithms. For example, the semiconductor sensor may be heated to 150° C., 200° C. or 300° C. and is more sensitive to hydrogen at the lower temperatures and more sensitive to methane at the higher temperature (FIG. 2A). The semiconductor sensor is not sensitive to carbon dioxide. The thermal sensor is used to sense carbon dioxide as well as hydrogen and methane at two temperatures of 100° C. and 250° C. In mili second (ms) durations, 4 data points from the two sensors can be read and thus a continuous line graph of the concentrations may be produced.

**[0037]** Other gas sensors such as NO<sub>x</sub> and H<sub>2</sub>S as well as volatile organic compound sensors may be used.

**[0038]** In addition, a temperature sensor **14** is included. Other sensors such as pH sensors may be included to provide environmental information for the gas analysis.

**[0039]** The gas sensors are enclosed in a compartment of the capsule sealed from the electronic components. This compartment is enclosed by a gas permeable membrane **12** preferably a graphene polymer containing nanoparticles of silver to protect the surface from bacterial growth.

**[0040]** Electronic circuits **15**, **18** (already available technology may be adapted): consists of a data acquisition system which switches between the sensors, and a coder and modulator that produce the digital data and sends it to the antenna **17** for transmission to the associated data receiver. Commercial bands (such as 433 MHz) are used for this application as electromagnetic waves in this frequency range can safely penetrate the human tissues. Other commercial bands may be used in various applications. Coding is required to assure that the unique data is sent from each individual capsule. The transmission antenna **17** is a pseudo patch type for transmitting data to the outside of the body data acquisition system. Power source **16** is a battery or super capacitor that can supply the power for the sensors and electronic circuits. A life time of at least 48 hours is required for digestive tract capsules. There may be less silver oxide batteries, depending on the needed life time and other specifications for the capsule.

**[0041]** The dimension of the capsule is preferably less than 1.1 mm in diameter and 2.6 mm in length to meet the 000 standard dimensions for human capsules. The body of

the capsule is preferably made of indigestible polymer, which is biocompatible. The body is preferably smooth and non-sticky to allow its passage in the shortest possible time and reduces the chances of any capsule retention.

**[0042]** An example of measurements that are conducted for calibrating the gas sensors is shown in FIGS. 2 A and B. Semiconducting and thermal conductivity sensor measurements at different concentration of gases: (A) semiconducting (mid measurement is after 1 ms and end measurement after 7 ms) and (B) thermal conductivity (mid measurement is after 400 ms and end measurement after 1000 ms).

#### Examples

**[0043]** The signals from the capsule are shown in FIGS. 3 and 4.

**[0044]** High Fibre

**[0045]** The gas profiles of a human volunteer under high fibre diet is shown in FIG. 3. The dietary fibre intake was over 55 g per day. Capsule was taken at 9 am and left the body at 6 am the day after. The hatched areas are representative of the passage through different sections of the small intestine (duodenum, jejunum and ileum)

**[0046]** Low Fibre

**[0047]** The gas profiles of a human volunteer under low fibre diet are shown in FIG. 4. The dietary fibre intake was under 15 g per day. Capsule was taken at 9 am and left the body three days after that. Only the first two days are demonstrated. The hatched areas are representative of the passage through different sections of the small intestine (duodenum, jejunum and ileum)

**[0048]** The protein intake was kept under 2,200 cal for the volunteer of 82 kg weight. The volunteer was given three meals a day with snacks in between. The volunteer was allowed to continue the normal day to day routine.

**[0049]** Low and High Fibre

**[0050]** A volunteer was kept under a low and high fibre diet and the gas profiles were measured using the human gas capsules.

**[0051]** The volunteer was kept under the strict high or low fibre diet for two days prior to taking the capsule. The capsule was taken at 9 am of the third day and the diet was continued till the capsule left body.

**[0052]** High fibre diet: the volunteer was given high fibre food such as oat, nuts, lentil, bean and pear. The total fibre intake was over 55 g per day.

**[0053]** Low fibre diet: volunteer was given low fibre food such as white bread, white rice, cucumber, tomato, fish and chicken. The total fibre intake was kept under 15 g per day.

**[0054]** The output readings from each sensor are shown in FIGS. 3 and 4 and this demonstrates the variations in gas concentrations and body temperature in relation to the events noted on the figure.

**[0055]** The changes of the gas concentrations of the graphs were investigated using the neural network software and the sensor calibration data, to show the concentration of the gases oxygen, hydrogen, carbon dioxide and methane over the same time period as below.

**[0056]** Low Fibre Example: FIG. 4

**[0057]** CO<sub>2</sub> in the stomach was approximately 35%

**[0058]** Oxygen content in the stomach increased by 5% in the 17 hours that capsule was in the stomach

**[0059]** H<sub>2</sub> is produced up to 0.5% in passage through the small intestine

**[0060]** After passage through the small intestine CO<sub>2</sub> increased by 7% and then decreased by 6% during the day time

**[0061]** After taking the high fibre food the H<sub>2</sub> concentration in the colon increased by more than 1.5%

**[0062]** A cycle is seen (bottom low fibre line 780 RHS axis) which is only sensitive to CO<sub>2</sub> and CH<sub>4</sub> (max at 12 pm and min at 10 pm)

**[0063]** High Fibre Example:

**[0064]** CO<sub>2</sub> in the stomach is approximately 50%

**[0065]** O<sub>2</sub> in the stomach increased by more than 5% with reference to the atmospheric concentration (21%) after the capsule was ingested

**[0066]** 0.25% increase in the H<sub>2</sub> in stomach after taking a lentil salad for lunch

**[0067]** H<sub>2</sub> is <0.1% in passage through the small intestine

**[0068]** About 0.25% H<sub>2</sub> is in the colon

**[0069]** CO<sub>2</sub> in the passage to the volunteers colon increased by 12.5%

**[0070]** The colon environment remains highly aerobic. The oxygen content seems to be over 10% in the colon region.

**[0071]** Benchmarking studies have been performed which compare the results of gas concentrations obtained through using: (i) the capsule and (ii) breath tests. Breath tests are the only other tool available using gas phase biomarkers as indicators of health. These studies showed that the capsule of the present invention significantly outperformed and more accurately identified the gas concentrations, for some gases by between 5,000 to 10,000 times when compared to the alternative breath tests.

**[0072]** Those skilled in the art will realise that this invention provides a valuable contribution to diagnosis of disorders in the human digestive system. It also generates information about the health status of humans and gas production in their digestive system. Those skilled in the art will also realise that this invention may be implemented in embodiments other than those described without departing from the core teachings of this invention.

1. A gas spectrometer for detecting gastrointestinal (GI) tract gases which includes a semi-conductor gas sensor and a thermal conductive gas sensor each operated at two different temperatures for a predetermined duration so that they are able to selectively detect oxygen, hydrogen, carbon dioxide and methane;

both gas sensors operating under the control of a micro-processor programmed with software to differentiate between the gases.

2. A gas spectrometer as claimed in claim 1 in which the change of operational temperature alters the selectivity to said gases in the GI tract and the microprocessor is programmed with a pattern recognition software to differentiate between the gases.

3. A capsule adapted to be introduced into the digestive system and gastrointestinal (GI) tract of a mammal which consists of

a capsule shaped container consisting of a wall material capable of being bio compatible with the digestive system and being adapted to protect the electronic and sensor devices contained in the capsule;

said capsule containing gas composition sensors operable at several temperature points for a short duration, a

temperature sensor, a micro controller, a power source and a wireless transmission device;  
said capsule wall incorporating gas permeable membranes adjacent said gas sensors; and  
the microprocessor being programmed to receive data signals from the sensors and convert the signals into gas composition and concentration data and temperature data suitable for transmission to an external computing device.

\* \* \* \* \*

专利名称(译)	气体传感器胶囊		
公开(公告)号	<a href="#">US20190183380A1</a>	公开(公告)日	2019-06-20
申请号	US16/325272	申请日	2017-08-14
[标]申请(专利权)人(译)	皇家墨尔本理工大学		
申请(专利权)人(译)	皇家墨尔本理工大学		
当前申请(专利权)人(译)	皇家墨尔本理工大学		
[标]发明人	KALANTAR ZADEH KOUROSH BEREAN KYLE HA NAM OU JIAN ZHEN		
发明人	KALANTAR-ZADEH, KOUROSH BEREAN, KYLE HA, NAM OU, JIAN ZHEN		
IPC分类号	A61B5/07 A61B5/00 A61B5/1491 G01N33/497 A61B5/145		
CPC分类号	A61B5/073 A61B5/002 A61B5/1491 A61B5/4238 A61B5/4255 A61B5/6861 G01N33/497 A61B5/1451 A61B5/14539 A61B5/14542 A61B2562/0271 A61B2562/162		
优先权	2016903219 2016-08-15 AU		
外部链接	<a href="#">Espacenet</a> <a href="#">USPTO</a>		

摘要(译)

一种适于引入哺乳动物的消化系统和胃肠道 (GI) 的胶囊，其由胶囊形容器组成，所述胶囊形容器由能够与消化系统生物相容并适于保护电子和传感器装置的壁材料组成。包含在胶囊中。胶囊包含可在几个温度点持续短时间的成分传感器，温度传感器，微控制器，电源和无线传输装置。胶囊壁包括与所述气体传感器相邻的透气膜。微处理器被编程为从传感器接收数据信号并将信号转换成适合于传输到外部计算设备的气体成分和浓度数据以及温度数据。

