



US 20170172452A1

(19) **United States**

(12) **Patent Application Publication**
LEE et al.

(10) **Pub. No.: US 2017/0172452 A1**
(43) **Pub. Date: Jun. 22, 2017**

(54) **APPARATUS AND METHOD FOR MEASURING BIOELECTRIC IMPEDANCE USING THREE-ELECTRODE SENSOR**

Publication Classification

(71) Applicant: **SAMSUNG ELECTRONICS CO., LTD.**, Suwon-si (KR)
(72) Inventors: **Yeol Ho LEE**, Anyang-si (KR); **Kak NAMKOONG**, Seoul (KR); **Myoung Hoon JUNG**, Bucheon-si (KR); **Young Jun KOH**, Seoul (KR)
(73) Assignee: **SAMSUNG ELECTRONICS CO., LTD.**, Suwon-si (KR)

(51) **Int. Cl.**
A61B 5/053 (2006.01)
A61B 5/0402 (2006.01)
A61B 5/00 (2006.01)
(52) **U.S. Cl.**
CPC *A61B 5/0537* (2013.01); *A61B 5/4869* (2013.01); *A61B 5/4872* (2013.01); *A61B 5/4875* (2013.01); *A61B 5/0022* (2013.01); *A61B 5/0533* (2013.01); *A61B 5/04028* (2013.01); *A61B 5/7405* (2013.01); *A61B 5/742* (2013.01); *A61B 5/7455* (2013.01); *A61B 5/6824* (2013.01)

(21) Appl. No.: **15/363,293**

(57) **ABSTRACT**

(22) Filed: **Nov. 29, 2016**

An apparatus and method for measuring a bioelectric impedance is provided. The apparatus may measure the bioelectric impedance using three electrodes. The apparatus may measure the bioelectric impedance by compensating for a change of a contact impedance.

(30) **Foreign Application Priority Data**

Dec. 17, 2015 (KR) 10-2015-0181192

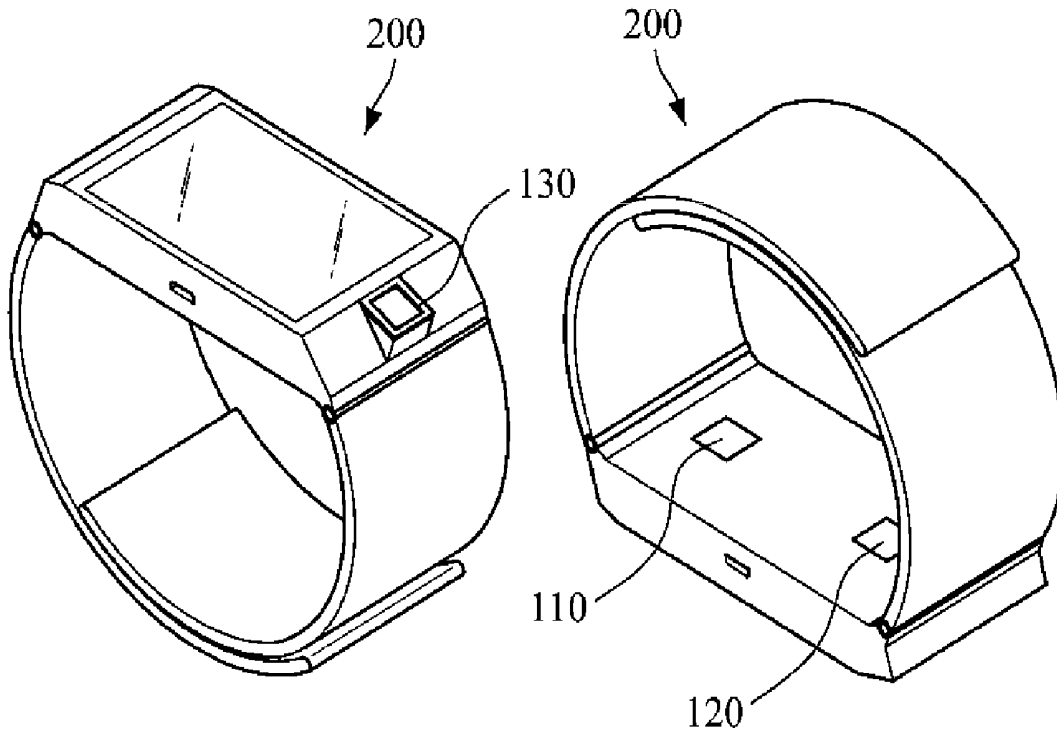

FIG. 1

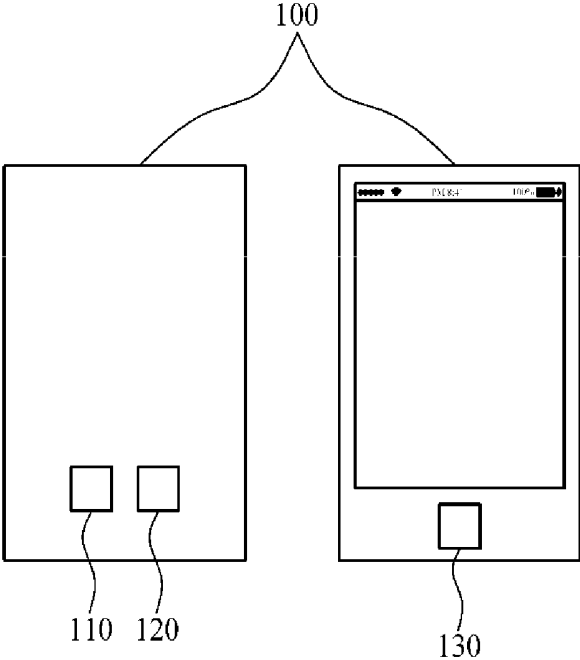

FIG. 2

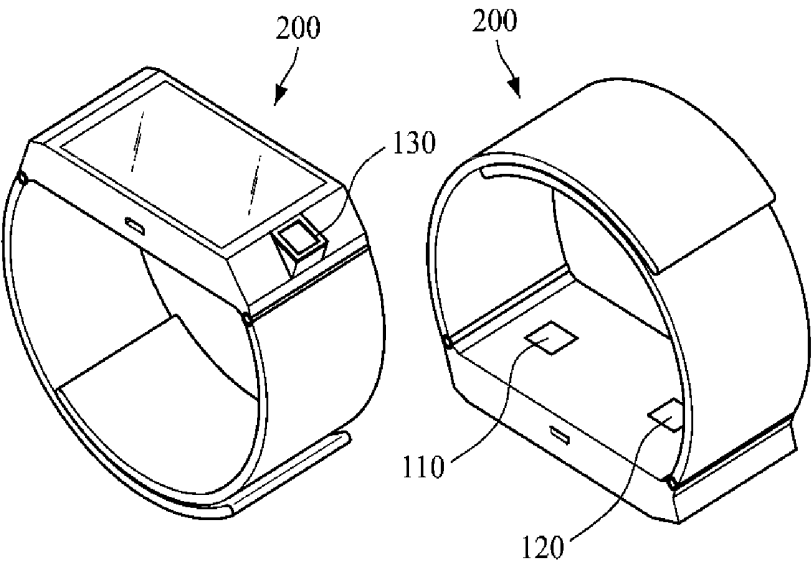

FIG. 3

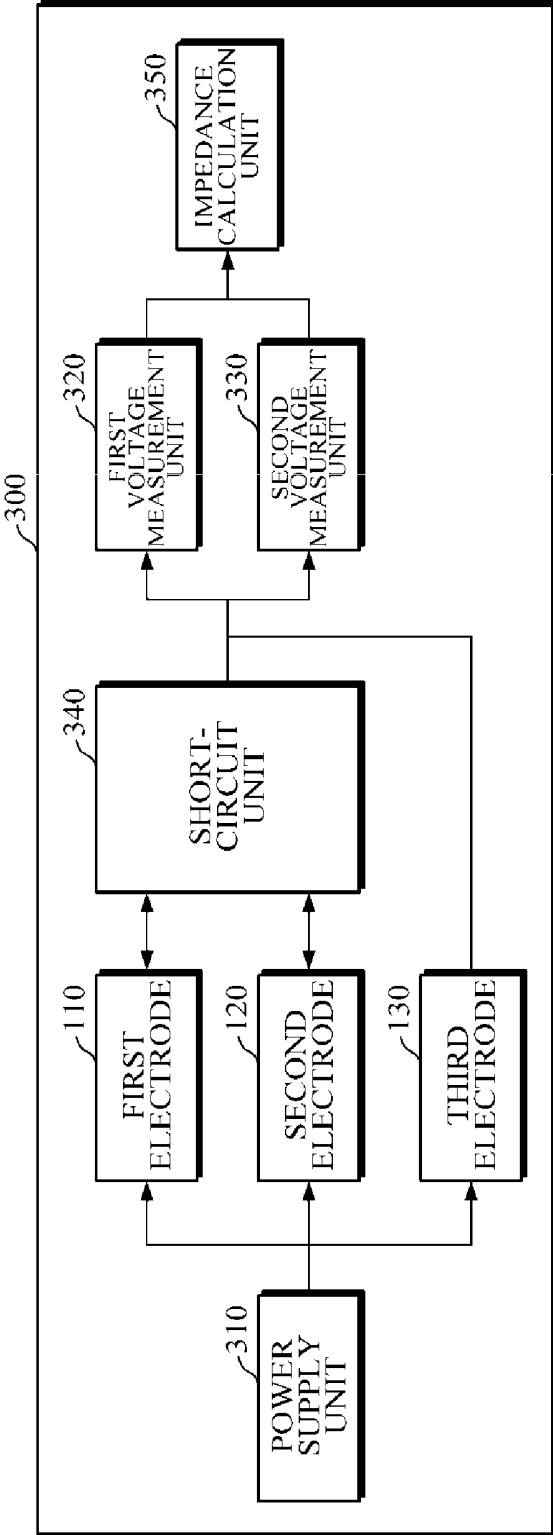

FIG. 4A

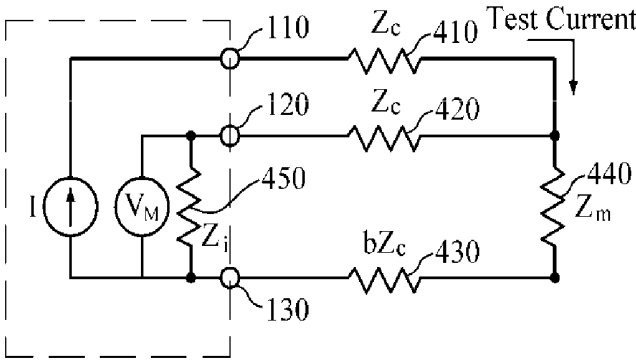

FIG. 4B

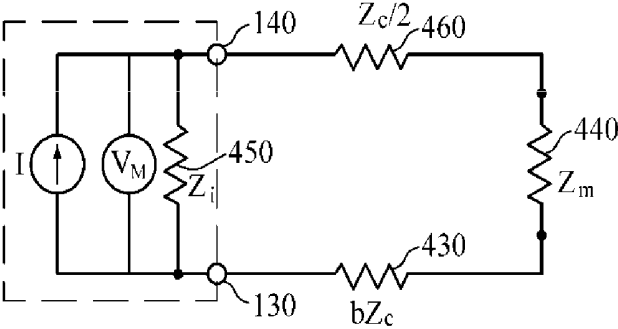

FIG. 5

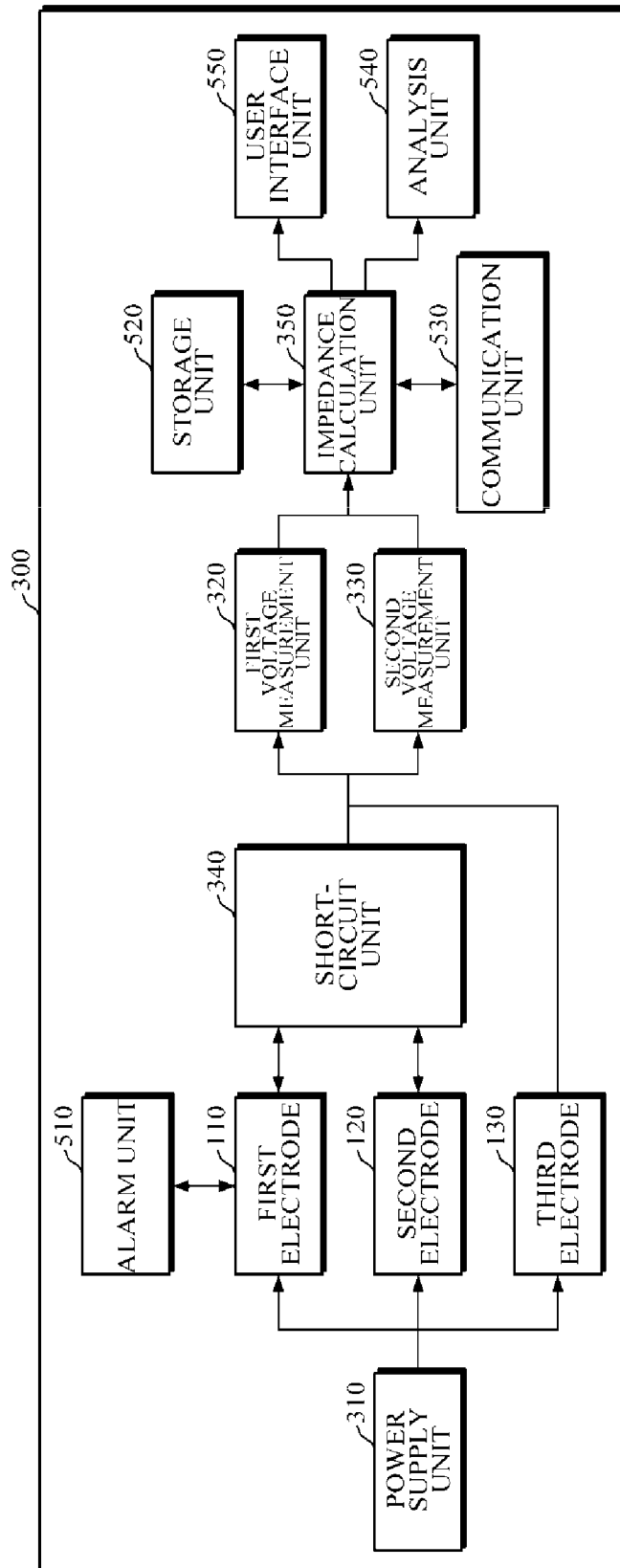
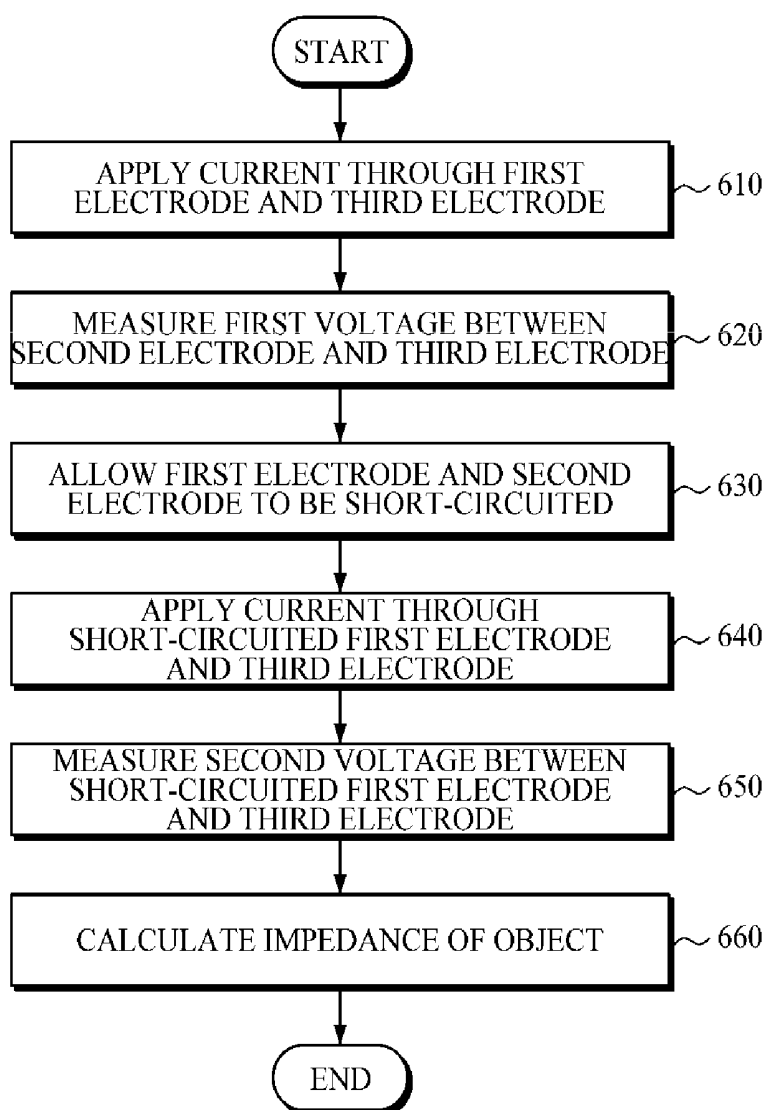

FIG. 6



**APPARATUS AND METHOD FOR
MEASURING BIOELECTRIC IMPEDANCE
USING THREE-ELECTRODE SENSOR**

CROSS-REFERENCE TO RELATED
APPLICATION

[0001] This application claims priority from Korean Patent Application No. 10-2015-0181192, filed on Dec. 17, 2015 in the Korean Intellectual Property Office, the disclosure of which is incorporated herein by reference in its entirety.

BACKGROUND

[0002] 1. Field

[0003] Apparatuses and methods consistent with exemplary embodiments relate to bioelectric impedance measurement technology, and more particularly to measuring a bioelectric impedance using a three-electrode sensor.

[0004] 2. Description of Related Art

[0005] Various medical apparatuses are being developed in order to diagnose a health condition of a patient. In the process of diagnosing the health, the importance of medical apparatuses for measuring a bioelectric signal of the patient is being highlighted due to convenience of the patient and rapidity of a health diagnosis result, etc.

[0006] Particularly, a bioelectric impedance may be used for monitoring a health or emotional condition of a body, and recently, various studies for miniaturization of an apparatus for measuring a bioelectric impedance are being progressed.

SUMMARY

[0007] One or more exemplary embodiments provide an apparatus and method for measuring a bioelectric impedance using three electrodes.

[0008] According to an aspect of an exemplary embodiment, there is provided a bioelectric impedance measurement apparatus including: a first electrode; a second electrode; a third electrode; a first voltage measurer configured to measure a first voltage between the second electrode and the third electrode generated by a current applied to an object through the first electrode and the third electrode, a short-circuit unit configured to short-circuit the first electrode to the second electrode, a second voltage measurer configured to measure a second voltage between the short-circuited first electrode and the third electrode generated by a current applied to the object through the short-circuited first electrode and the third electrode, and an impedance calculator configured to calculate a resulting impedance value of the object based on the first voltage and the second voltage.

[0009] The bioelectric impedance measurement apparatus may be implemented as a mobile device.

[0010] The bioelectric impedance measurement apparatus may be implemented as a wristwatch-type wearable device, and the first electrode and the second electrode may be disposed on a back surface of a body of the wristwatch-type wearable device.

[0011] The third electrode may be disposed on a front surface of the body of the wristwatch-type wearable device.

[0012] The third electrode may be disposed on a strap of the wristwatch-type wearable device.

[0013] The impedance calculator may calculate a first impedance based on the first voltage and the current applied to the object through the first electrode and the third electrode, calculate a second impedance based on the second voltage and the current applied to the object through the short-circuited first electrode and the third electrode, and calculate the resulting impedance value of the object based on the first impedance and the second impedance.

[0014] The impedance calculator may calculate the resulting impedance value based on a bioelectric impedance calculation equation defining a relationship of the impedance of the object, the first impedance, and the second impedance.

[0015] The bioelectric impedance calculation equation may be derived from a contact impedance generated by a contact between each electrode and the object.

[0016] The first, second and third electrodes may further be used to measure at least one of an electrocardiogram (ECG) and galvanic skin response (GSR).

[0017] The bioelectric impedance measurement apparatus may further include a power supply configured to apply a predetermined current to the object through the first electrode and the third electrode or the short-circuited first electrode and the third electrode.

[0018] According to an aspect of another exemplary embodiment, there is provided a bioelectric impedance measurement method including: applying a current to an object through a first electrode and a third electrode, measuring a first voltage between a second electrode and the third electrode, short-circuiting the first electrode to the second electrode, applying a current to the object through the short-circuit first electrode and the third electrode, measuring a second voltage between the short-circuited first electrode and the third electrode, and calculating a resulting impedance value of the object based on the first voltage and the second voltage.

[0019] The calculating the resulting impedance value of the object may include, calculating a first impedance based on the first voltage and the current applied to the object through the first electrode and the third electrode, calculating a second impedance based on the second voltage and the current applied to the object through the short-circuited first electrode and the third electrode, and calculating the resulting impedance value of the object based on the first impedance and the second impedance.

[0020] The calculating the resulting impedance value of the object may use a bioelectric impedance calculation equation defining a relationship of the resulting impedance value of the object, the first impedance, and the second impedance.

[0021] The bioelectric impedance calculation equation may be derived from a contact impedance generated by a contact between each electrode and the object.

BRIEF DESCRIPTION OF THE DRAWINGS

[0022] The above and/or other aspects will be more apparent by describing certain exemplary embodiments, with reference to the accompanying drawings, in which:

[0023] FIG. 1 is a diagram illustrating an electrode placement of a mobile device according to an exemplary embodiment;

[0024] FIG. 2 is a diagram illustrating an electrode placement of a wristwatch-type wearable device according to an exemplary embodiment;

[0025] FIG. 3 is a diagram illustrating a bioelectric impedance measurement apparatus according to an exemplary embodiment;

[0026] FIGS. 4A and 4B are diagrams for describing a process of deriving a bioelectric impedance calculation equation;

[0027] FIG. 5 is a block diagram illustrating a bioelectric impedance measurement apparatus according to another exemplary embodiment; and

[0028] FIG. 6 is a flowchart for describing a bioelectric impedance measurement method according to an exemplary embodiment.

DETAILED DESCRIPTION

[0029] Exemplary embodiments are described in greater detail below with reference to the accompanying drawings.

[0030] In the following description, like drawing reference numerals are used for like elements, even in different drawings. The matters defined in the description, such as detailed construction and elements, are provided to assist in a comprehensive understanding of the exemplary embodiments. However, it is apparent that the exemplary embodiments can be practiced without those specifically defined matters. Also, well-known functions or constructions are not described in detail since they would obscure the description with unnecessary detail.

[0031] Throughout the drawings and the detailed description, unless otherwise described, the same drawing reference numerals should be understood to refer to the same elements, features, and structures. The relative size and depiction of these elements may be exaggerated for clarity, illustration, and convenience.

[0032] As is traditional in the field of the inventive concept, certain elements of exemplary embodiments are described, and illustrated in the drawings, in terms of functional blocks, units and/or modules. Those skilled in the art will appreciate that these blocks, units and/or modules are physically implemented by electronic (or optical) circuits such as logic circuits, discrete components, microprocessors, hard-wired circuits, memory elements, wiring connections, and the like, which may be formed using semiconductor-based fabrication techniques or other manufacturing technologies. In the case of the blocks, units and/or modules being implemented by microprocessors or similar, they may be programmed using software (e.g., microcode) to perform various functions discussed herein and may optionally be driven by firmware and/or software. Alternatively, each block, unit and/or module may be implemented by dedicated hardware, or as a combination of dedicated hardware to perform some functions and a processor (e.g., one or more programmed microprocessors and associated circuitry) to perform other functions. Also, each block, unit and/or module of the embodiments may be physically separated into two or more interacting and discrete blocks, units and/or modules without departing from the scope of the inventive concepts. Further, the blocks, units and/or modules of the embodiments may be physically combined into more complex blocks, units and/or modules without departing from the scope of the inventive concept.

[0033] FIG. 1 is a diagram illustrating an electrode placement of a mobile device according to an exemplary embodiment.

[0034] A mobile device 100 may be a device which measures a bioelectric impedance, a bioelectric signal (for

example, an electrocardiogram (ECG), galvanic skin response (GSR), etc.) in addition to the bioelectric impedance, and may include a mobile phone, a smart phone, a tablet personal computer (PC), a notebook computer, a personal digital assistant (PDA), a portable multimedia player (PMP), a navigation unit, an MP3 player, a digital camera, a wearable device, etc. However, the mobile device is not limited to the examples described above, and may include various devices.

[0035] According to an exemplary embodiment, the mobile device 100 may measure an impedance of an object using a bioelectrical impedance analysis (BIA) method of measuring an electric impedance of the object by applying a current to the object. Here, the object may mean a user or a body of the user.

[0036] The mobile device 100 may include three electrodes 110, 120, and 130.

[0037] A first electrode 110 may be a current applying electrode used for applying a current to an object, a second electrode 120 may be a voltage measuring electrode used for measuring a voltage of the object, and a third electrode 130 may be a common electrode used for applying a current to the object and also measuring the voltage of the object.

[0038] The three electrodes 110, 120, and 130 may be disposed in various forms on the mobile device 100. That is, the three electrodes 110, 120, and 130 may be disposed in various forms by considering convenience of the user, and a design, a shape and a structure of the mobile device 100.

[0039] For example, as shown in FIG. 1, the first electrode 110 and the second electrode 120 may be disposed on a back surface (or a back side, or a rear surface) of the mobile device 100, and the third electrode 130 may be disposed on a front surface of the mobile device 100. In this case, the electrodes 110, 120, and 130 may be disposed in an area excluding a portion in which an antenna of the mobile device 100 is disposed so as to prevent it from obstructing transmission and reception of a radio wave.

[0040] Further, according to an exemplary embodiment, a logo engraved in the mobile device 100 may be used as an electrode, and the electrodes may be disposed on an edge of the mobile device.

[0041] Meanwhile, the electrodes 110, 120, and 130 may be configured in various shapes. In an example of FIG. 1, the three electrodes 110, 120, and 130 are illustrated in a rectangular shape, but may have a round shape, a diamond shape, a triangular shape, etc., and each of the three electrodes may be configured to have a different shape.

[0042] Further, the electrodes 110, 120, and 130 may be disposed to easily come into contact with an object by being disposed at a position higher than a surface of the mobile device 100, and may have a pattern such as a dot pattern, a hair pattern, an engraved pattern, etc. so that the user may easily recognize the position of the electrode.

[0043] According to an exemplary embodiment, the electrodes 110, 120, and 130 may be configured in various materials. For example, the electrodes 110, 120, and 130 may be configured using metal, conductive rubber, conductive plastic, conductive fibers, conductive ceramic, etc. Further, when using a metal, the electrodes 110, 120, and 130 may be coated with titanium nitride (TiN), titanium carbon nitride (TiCN), or chromium nitride (CrN) so as to increase surface conductivity and scratch resistance of the electrode surface.

[0044] Meanwhile, the three electrodes **110**, **120**, and **130** of the mobile device **100** may be used for measuring a bioelectric impedance and also a bioelectric signal (for example, the ECG, the GSR, etc.) in addition to the bioelectric impedance.

[0045] FIG. 2 is a diagram illustrating an electrode placement of a wristwatch-type wearable device according to an exemplary embodiment. FIG. 2 illustrates an example in which the mobile device **100** shown in FIG. 1 is implemented as the wristwatch-type wearable device.

[0046] Referring to FIG. 2, the first electrode **110** and the second electrode **120** may be disposed on a back surface (or a back side or a rear surface) of a body of the device which is in contact with skin of a user so as to naturally come into contact with the skin of the user when wearing a device **200**. Further, as shown in FIG. 2, the first electrode **110** and the second electrode **120** may be disposed to be spaced apart from each other by a predetermined interval in the same direction as a length of a strap. In other words, the first electrode **110** and the second electrode **120** may be disposed to be spaced apart from each other by the predetermined interval in the longitudinal direction of the strap and also in the longitudinal direction of the body of the wearable device. However, the placement of the first and second electrodes **110** and **120** is not limited thereto. For example, the first and second electrodes **110** and **120** may be disposed to be spaced apart from each other by the predetermined interval in a direction vertical to a length direction of the strap, etc., and may be disposed in various ways.

[0047] The third electrode **130** may be disposed on a front surface of the body of the device. The third electrode **130**, as shown in FIG. 2, may be disposed at a lower portion of the surface so as to prevent the third electrode from obstructing a display. However, the placement of the third electrode **130** is not limited thereto, and the third electrode **130** may be disposed in an upper front portion, a left front portion, or a right front portion of the body of the device, and may be disposed in a right side or a left side of the body of the device. Further, the third electrode **130** may be disposed on the strap.

[0048] FIG. 3 is a diagram illustrating a bioelectric impedance measurement apparatus according to an exemplary embodiment. According to an exemplary embodiment, a bioelectric impedance measurement apparatus **300** may be implemented as the mobile device **100** shown in FIG. 1, or the wristwatch-type wearable device **200** shown in FIG. 2.

[0049] When the bioelectric impedance measurement apparatus **300** is implemented as a small device such as the mobile device, since a dimension of the electrode is decreased, a dimension in which skin of the object is in contact with the electrode may be decreased, and thus a contact impedance generated according to the contact of the electrode and the object may be increased. The increase of the contact impedance may obstruct the impedance measurement of the object, and thus accuracy of the impedance measurement may be decreased.

[0050] Further, since a four-electrode method using two current applying electrodes and two voltage measuring electrodes needs at least four electrodes, the method has a limitation when applied to a small device which has insufficient space for the placement of the electrodes.

[0051] According to an exemplary embodiment, the bioelectric impedance measurement apparatus **300** may measure an impedance of an object by compensating for a

change of a contact impedance generated due to the dimensional decrease of the electrode using the three electrodes.

[0052] Referring to FIG. 3, the bioelectric impedance measurement apparatus **300** may include the three electrodes **110**, **120**, and **130**, a power supply unit (e.g., power supply) **310**, a first voltage measurement unit **320**, a second voltage measurement unit **330**, a short-circuit unit **340**, and an impedance calculation unit **350**. The impedance calculation unit **350** may be implemented by a processor.

[0053] The first electrode **110** may be a current applying electrode used for applying a current to an object, a second electrode **120** may be a voltage measuring electrode used for measuring a voltage of the object, and a third electrode **130** may be a common electrode used for applying a current to the object and also measuring the voltage of the object. Since the placement of the three electrodes **110**, **120**, and **130** was described in detail with reference to FIGS. 1 and 2, a detailed description thereof will be omitted.

[0054] The power supply unit **310** may apply a predetermined current to the object through the three electrodes **110**, **120**, and **130**. For example, the power supply unit **310** may apply the predetermined current to the object through the third electrode **130**. Further, after the first electrode **110** and the second electrode **120** are short-circuited, the power supply unit **310** may apply the predetermined current to the object through the short-circuited first electrode (or the short-circuited second electrode) and the third electrode **130**. In this case, the predetermined current may be an alternating current (AC) having a frequency of 1 Hz to 1 GHz.

[0055] The first voltage measurement unit **320** may measure a voltage (hereinafter, it may be referred to as a first voltage) of both ends of the second and third electrodes **120** and **130** generated by the current applied to the object through the first electrode **110** and the third electrode **130**.

[0056] The short-circuit unit **340** may allow the first and second electrodes **110** and **120** to be short-circuited. The short-circuit unit **340** may operate the three electrodes **110**, **120**, and **130** as if they were two electrodes by allowing the first and second electrodes **110** and **120** to be short-circuited.

[0057] The second voltage measurement unit **330** may measure a voltage (hereinafter, it may be referred to as a second voltage) of both ends of the short-circuited first electrode (or the short-circuited second electrode) and the third electrode **130** generated by the current applied to the object through the short-circuited first electrode (or the short-circuited second electrode) and the third electrode **130**.

[0058] Meanwhile, the first voltage measurement unit **320** and the second voltage measurement unit **330** may include a digital multi-meter for measuring the voltage of both ends of the electrodes.

[0059] The impedance calculation unit **350** may calculate the impedance of the object based on the first voltage and the second voltage. For example, the impedance calculation unit **350** may calculate a first impedance using the current applied to the object through the first electrode **110** and the third electrode **130** and the first voltage, and calculate a second impedance using the current applied to the object through the short-circuited first electrode (or the short-circuited second electrode) and the third electrode **130** and the second voltage. Further, the impedance calculation unit **350** may calculate the impedance of the object based on the first impedance, the second impedance, and a bioelectric impedance calculation equation.

[0060] The bioelectric impedance calculation equation may define a relationship of the first impedance, the second impedance, and a bioelectric impedance, and be derived by considering the contact impedance generated by the contact of each electrode and the object. For example, the bioelectric impedance calculation equation may be expressed by Equation 1.

$$Z_m = \frac{Z_1 Z_i^2 + Z_2 Z_1 Z_i - 2b Z_2 Z_i^2 + 2b Z_1 Z_i^2}{Z_1 Z_i + Z_i^2 - Z_2 Z_1 - Z_2 Z_i} \quad [\text{Equation 1}]$$

[0061] Here, Z_m represents the impedance of the object, Z_1 represents the first impedance, Z_2 represents the second impedance, Z_i represents an internal resistance of the voltage measurement unit, b represents a weight of the contact impedance of the third electrode which is commonly used for applying the current and measuring the voltage. In this case, b may be experimentally determined.

[0062] FIGS. 4A and 4B are diagrams for describing a process of deriving a bioelectric impedance calculation equation. In detail, FIG. 4A is a diagram illustrating an equivalent circuit when measuring a first voltage, and FIG. 4B is a diagram illustrating an equivalent circuit when measuring a second voltage.

[0063] Referring to FIG. 4A, the equivalent circuit when measuring the first voltage may be illustrated by a contact impedance Z_c 410 generated by the contact between the first electrode 110 and an object, a contact impedance Z_c 420 generated by the contact between the second electrode 120 and the object, a contact impedance bZ_c 430 generated by the contact between the third electrode 130 and the object, an impedance Z_m 440 of the object, and an internal impedance Z_i 450 of the voltage measurement unit.

[0064] When the power supply unit 310 applies an output current I to the object through the first electrode 110 and the third electrode 130, a first voltage V_1 measured between the second electrode 120 and the third electrode 130 may be expressed by Equation 2, and a first impedance Z_1 calculated in Equation 2 may be expressed by Equation 3.

$$V_1 = I \frac{Z_i}{1 + \frac{Z_c + Z_i}{bZ_c + Z_m}} \quad [\text{Equation 2}]$$

$$Z_1 = \frac{V_1}{I} = \frac{Z_i}{1 + \frac{Z_c + Z_i}{bZ_c + Z_m}} \quad [\text{Equation 3}]$$

[0065] Here, b may be the weight of the contact impedance of the third electrode which is commonly used for applying the current and measuring the voltage, and it may be experimentally determined.

[0066] Referring to FIG. 4B, when measuring the second voltage, the contact impedance Z_c 410 and the contact impedance Z_c 420 which are connected in parallel may be added to the equivalent circuit when measuring the first voltage since the first electrode 110 and the second electrode 120 are short-circuited. That is, the equivalent circuit when measuring the second voltage may be illustrated by a contact impedance

$$\frac{Z_c}{2}$$

460 generated by the contact of a short-circuited first electrode (or a short-circuited second electrode) 140 and the object, a contact impedance bZ_c 430 generated by the contact of the third electrode 130 and the object, an impedance Z_m 440 of the object, and an internal impedance Z_i 450 of the voltage measurement unit.

[0067] When the power supply unit 310 applies the output current I to the object through the short-circuited first electrode (or the shorted-circuited second electrode) 140 and the third electrode 130, a second voltage V_2 measured between the short-circuited first electrode (or the shorted-circuited second electrode) 140 and the third electrode 130 may be expressed by Equation 4, and a second impedance Z_2 calculated in Equation 4 may be expressed by Equation 5.

$$V_2 = I \frac{1}{\frac{1}{Z_m + (b + \frac{1}{2})Z_c} + \frac{1}{Z_i}} \quad [\text{Equation 4}]$$

$$Z_2 = \frac{V_2}{I} = \frac{1}{\frac{1}{Z_m + (b + \frac{1}{2})Z_c} + \frac{1}{Z_i}} \quad [\text{Equation 5}]$$

[0068] The bioelectric impedance calculation equation of Equation 1 may be derived from Equations 3 and 5.

[0069] FIG. 5 is a block diagram illustrating a bioelectric impedance measurement apparatus according to another exemplary embodiment.

[0070] Referring to FIG. 5, a bioelectric impedance measurement apparatus 500 may further include an alarm unit 510, a storage unit (e.g., storage or memory) 520, a communication unit 530, an analysis unit 540, and a user interface unit 550 when compared with the bioelectric impedance measurement apparatus 300. The alarm unit 510, the communication unit 530, the analysis unit 540, and the user interface unit 550 may be implemented by one or more processors.

[0071] The alarm unit 510 may determine a contact condition between each of the electrodes 110, 120, and 130 of the bioelectric impedance measurement apparatus 500 and an object, and output an alarm message when the contact condition is not good. According to another exemplary embodiment, the contact condition between each of the electrodes 110, 120, and 130 and the object may be determined based on an electrical resistance between the electrodes 110, 120, and 130 or a pressure applied to each of the electrodes 110, 120, or 130. For this, the alarm unit 510 may include a pressure sensor.

[0072] The alarm unit 510 may output the alarm message in various ways. For example, the alarm unit 510 may output the alarm message using a tactile method such as vibration, etc., an auditory method such as a sound, etc. and a visual method, etc. through the user interface unit 550.

[0073] The storage unit 520 may store a program for operating and controlling the bioelectric impedance measurement apparatus 500, and store input and output data. For example, the storage unit 520 may store a program for an

impedance estimation performed in the impedance calculation unit **350** and/or information related to a bioelectric impedance estimation equation. Further, the storage unit **520** may store voltage measurement results of the first voltage measurement unit **320** and the second voltage measurement unit **330** needed for the operation of the impedance calculation unit **350**.

[0074] The storage unit **520** may include a storage medium of at least one-type among a flash memory type, a hard disk type, a multimedia card micro type, a card type memory (for example, secure digital (SD) or extreme digital (XD) memory, etc.), a random access memory (RAM), a static RAM (SRAM), a read-only memory (ROM), an electrically erasable and programmable ROM (EEPROM), a programmable ROM (PROM), a magnetic memory, a magnetic disk, and an optical disk.

[0075] The communication unit **530** may perform communication with an external device. The communication unit **530** may transmit a bioelectric impedance measurement result to the external device, or receive a variety of information which is conducive to the bioelectric impedance measurement from the external device.

[0076] In this case, the external device may be a medical apparatus using the measured bioelectric impedance information, a printer outputting a result, or a display device displaying the measured impedance information. In addition, the external device may be a smart phone, a mobile phone, a PDA, a laptop computer, a PC, and a mobile or non-mobile computing device, but is not limited thereto.

[0077] The communication unit **530** may communicate with the external device using Bluetooth communication, Bluetooth low energy (BLE) communication, near field communication (NFC), wireless local area network (WLAN) communication, Zigbee communication, infrared data association (IrDA) communication, wireless-fidelity (Wi-Fi) direct (WFD) communication, ultra-wideband (UWB) communication, Ant+ communication, Wi-Fi communication, radio frequency identification (RFID) communication, etc. However, those are merely an example and the communication is not limited thereto.

[0078] The analysis unit **540** may estimate a total body water (TBW), a body fat (FAT), a body fat ratio (% FAT), etc. based on the impedance of the object calculated by the impedance calculation unit **340** and object information (for example, a height, a weight, age, and gender, etc. of the object).

[0079] The user interface unit **550** may be a device for an interface of the bioelectric impedance measurement apparatus **500** and a user and/or other external devices, and include an input unit and an output unit. Here, the user may be a target for measuring the bioelectric impedance, that is, the object, but may have a concept broader than the object as a person who is capable of using the bioelectric impedance measurement apparatus **500** such as a medical expert.

[0080] Information needed for operating the bioelectric impedance measurement apparatus **500** may be input through the user interface unit **550**, and the bioelectric impedance measurement result may be output. The user interface unit **550** may include a button, a connector, a keypad, a display, etc. Further, the user interface unit **550** may further include a component such as a sound output unit or a vibration motor, etc.

[0081] FIG. 6 is a flowchart for describing a bioelectric impedance measurement method according to an exemplary embodiment.

[0082] Referring to FIGS. 3 and 6, the bioelectric impedance measurement apparatus **300** may apply a predetermined current to an object using the first electrode **110** and the third electrode **130** (operation S610). In this case, the current may be an AC having a frequency of 1 Hz to 1 GHz.

[0083] The bioelectric impedance measurement apparatus **300** may measure a first voltage between the second electrode **120** and the third electrode **130** (operation S620).

[0084] The bioelectric impedance measurement apparatus **300** may allow the first electrode **110** and the second electrode **120** to be short-circuited (operation S630). The bioelectric impedance measurement apparatus **300** may operate the three electrodes **110**, **120**, and **130** as if they were two electrodes by allowing the first electrode **110** and the second electrode **120** to be short-circuited.

[0085] The bioelectric impedance measurement apparatus **300** may apply the predetermined current to the object using the short-circuited first electrode (or the short-circuited second electrode) and the third electrode **130** (operation S640).

[0086] The bioelectric impedance measurement apparatus **300** may measure a voltage (hereinafter, it may be referred to as a second voltage) between the short-circuited first electrode (or the short-circuited second electrode) and the third electrode **130** (operation S650).

[0087] The bioelectric impedance measurement apparatus **300** may calculate an impedance of the object based on the first voltage and the second voltage (operation S660). For example, the bioelectric impedance measurement apparatus **300** may calculate a first impedance using the first voltage and the current applied through the first electrode **110** and the third electrode **130**, may calculate a second impedance using the second voltage and the current applied through the short-circuited first electrode (short-circuited second electrode) and the third electrode **130**, and may calculate the impedance of the object based on the first impedance, the second impedance, and the bioelectric impedance calculation equation.

[0088] The bioelectric impedance calculation equation may define a relationship of the first impedance, the second impedance, and a bioelectric impedance, and be derived by considering a contact impedance generated by the contact of each electrode and the object. For example, the bioelectric impedance calculation equation may be expressed by Equation 1. Since the bioelectric impedance calculation equation was described above with reference to FIGS. 4A and 4B, a detailed description thereof will be omitted.

[0089] While not restricted thereto, an exemplary embodiment can be implemented as computer readable codes in a computer readable recording medium. Codes and code segments constituting the computer program can be easily inferred by a skilled computer programmer in the art. The computer readable recording medium includes all types of recording media in which computer readable data can be stored. Examples of the computer readable recording medium include a ROM, a RAM, a compact disk (CD)-ROM, a magnetic tape, a floppy disk, and an optical disk, etc. Further, the computer readable recording medium may be distributed to computer systems over a network in which computer readable codes may be stored and executed in a distributed manner. Also, an exemplary embodiment may be

written as a computer program transmitted over a computer-readable transmission medium, such as a carrier wave, and received and implemented in general-use or special-purpose digital computers that execute the programs. Moreover, it is understood that in exemplary embodiments, one or more units of the above-described apparatuses and devices can include circuitry, a processor, a microprocessor, etc., and may execute a computer program stored in a computer-readable medium.

[0090] The foregoing exemplary embodiments are merely exemplary and are not to be construed as limiting. The present teaching can be readily applied to other types of apparatuses. Also, the description of the exemplary embodiments is intended to be illustrative, and not to limit the scope of the claims, and many alternatives, modifications, and variations will be apparent to those skilled in the art.

What is claimed is:

1. A bioelectric impedance measurement apparatus comprising:

- a first electrode;
- a second electrode;
- a third electrode;

a first voltage measurer configured to measure a first voltage between the second electrode and the third electrode generated by a current applied to an object through the first electrode and the third electrode;

a short-circuit unit configured to short-circuit the first electrode to the second electrode;

a second voltage measurer configured to measure a second voltage between the short-circuited first electrode and the third electrode generated by a current applied to the object through the short-circuited first electrode and the third electrode; and

an impedance calculator configured to calculate a resulting impedance value of the object based on the first voltage and the second voltage.

2. The bioelectric impedance measurement apparatus of claim 1, wherein the bioelectric impedance measurement apparatus is implemented as a mobile device.

3. The bioelectric impedance measurement apparatus of claim 2, wherein the bioelectric impedance measurement apparatus is implemented as a wristwatch-type wearable device, and the first electrode and the second electrode are disposed on a back surface of a body of the wristwatch-type wearable device.

4. The bioelectric impedance measurement apparatus of claim 3, wherein the third electrode is disposed on a front surface of the body of the wristwatch-type wearable device.

5. The bioelectric impedance measurement apparatus of claim 3, wherein the third electrode is disposed on a strap of the wristwatch-type wearable device.

6. The bioelectric impedance measurement apparatus of claim 1, wherein the impedance calculator is further configured to calculate a first impedance based on the first voltage and the current applied to the object through the first electrode and the third electrode, calculate a second impedance based on the second voltage and the current applied to the object through the short-circuited first electrode and the

third electrode, and calculate the resulting impedance value of the object based on the first impedance and the second impedance.

7. The bioelectric impedance measurement apparatus of claim 6, wherein the impedance calculator calculates the resulting impedance value based on a bioelectric impedance calculation equation defining a relationship of the resulting impedance value of the object, the first impedance, and the second impedance.

8. The bioelectric impedance measurement apparatus of claim 7, wherein the bioelectric impedance calculation equation is derived from a contact impedance generated by a contact between each electrode and the object.

9. The bioelectric impedance measurement apparatus of claim 1, wherein the first, second and third electrodes are further used to measure at least one of an electrocardiogram (ECG) and galvanic skin response (GSR).

10. The bioelectric impedance measurement apparatus of claim 1, further comprising:

a power supply configured to apply a predetermined current to the object through the first electrode and the second electrode or the short-circuited first electrode and the third electrode.

11. A bioelectric impedance measurement method, comprising:

applying a current to an object through a first electrode and a third electrode;

measuring a first voltage between a second electrode and the third electrode;

short-circuiting the first electrode to the second electrode;

applying a current to the object through the short-circuited first electrode and the third electrode;

measuring a second voltage between the short-circuited first electrode and the third electrode; and

calculating a resulting impedance value of the object based on the first voltage and the second voltage.

12. The bioelectric impedance measurement method of claim 11, wherein the calculating the resulting impedance value of the object comprises:

calculating a first impedance based on the first voltage and the current applied to the object through the first electrode and the third electrode;

calculating a second impedance based on the second voltage and the current applied to the object through the short-circuited first electrode and the third electrode; and

calculating the resulting impedance value of the object based on the first impedance and the second impedance.

13. The bioelectric impedance measurement method of claim 12, wherein the calculating the resulting impedance value of the object uses a bioelectric impedance calculation equation defining a relationship of the resulting impedance value of the object, the first impedance, and the second impedance.

14. The bioelectric impedance measurement method of claim 13, wherein the impedance calculation equation is derived from a contact impedance generated by a contact between each electrode and the object.

* * * * *

专利名称(译)	使用三电极传感器测量生物电阻抗的装置和方法		
公开(公告)号	US20170172452A1	公开(公告)日	2017-06-22
申请号	US15/363293	申请日	2016-11-29
[标]申请(专利权)人(译)	三星电子株式会社		
申请(专利权)人(译)	SAMSUNG ELECTRONICS CO. , LTD.		
当前申请(专利权)人(译)	SAMSUNG ELECTRONICS CO. , LTD.		
[标]发明人	LEE YEOL HO NAMKOONG KAK JUNG MYOUNG HOON KOH YOUNG JUN		
发明人	LEE, YEOL HO NAMKOONG, KAK JUNG, MYOUNG HOON KOH, YOUNG JUN		
IPC分类号	A61B5/053 A61B5/0402 A61B5/00		
CPC分类号	A61B5/0537 A61B5/4869 A61B5/4872 A61B5/4875 A61B5/0022 A61B5/6824 A61B5/04028 A61B5/7405 A61B5/742 A61B5/7455 A61B5/0533		
优先权	1020150181192 2015-12-17 KR		
其他公开文献	US10420483		
外部链接	Espacenet USPTO		

摘要(译)

提供了一种用于测量生物电阻抗的装置和方法。该装置可以使用三个电极测量生物电阻抗。该装置可以通过补偿接触阻抗的变化来测量生物电阻抗。

