



US 20150216461A1

(19) **United States**

(12) **Patent Application Publication**
Barrett et al.

(10) **Pub. No.: US 2015/0216461 A1**

(43) **Pub. Date: Aug. 6, 2015**

(54) **PHYSIOLOGICAL SENSOR**

Publication Classification

(71) Applicant: **Covidien LP**, Mansfield, MA (US)

(51) **Int. Cl.**
A61B 5/1455 (2006.01)
A61B 5/00 (2006.01)
A61B 5/024 (2006.01)

(72) Inventors: **Bruce J. Barrett**, Birmingham, AL (US); **Oleg Gonopolsky**, West Bloomfield, MI (US); **Ronald A. Widman**, Macomb, MI (US); **Rick Scheuing**, Rochester Hills, MI (US)

(52) **U.S. Cl.**
CPC *A61B 5/14553* (2013.01); *A61B 5/02427* (2013.01); *A61B 5/6814* (2013.01)

(21) Appl. No.: **14/688,618**

(57) **ABSTRACT**

(22) Filed: **Apr. 16, 2015**

A sensor used to measure physiological characteristics of body tissues is provided. The physiological sensor includes a first light source assembly having a first light source in parallel with a second light source. Each of the first light source and the second light source have an anode and a cathode. A second light source assembly includes a third light source in parallel with a fourth light source. Each of the third light source and the fourth light source have an anode and a cathode. The anode of the first light source is electrically connected to the cathode of the second light source, the anode of said third light source, and the cathode of said fourth light source. The anode of the third light source is electrically connected to the cathode of the fourth light source.

Related U.S. Application Data

(63) Continuation of application No. 13/755,432, filed on Jan. 31, 2013, which is a continuation of application No. 11/963,174, filed on Dec. 21, 2007, now Pat. No. 8,380,272.

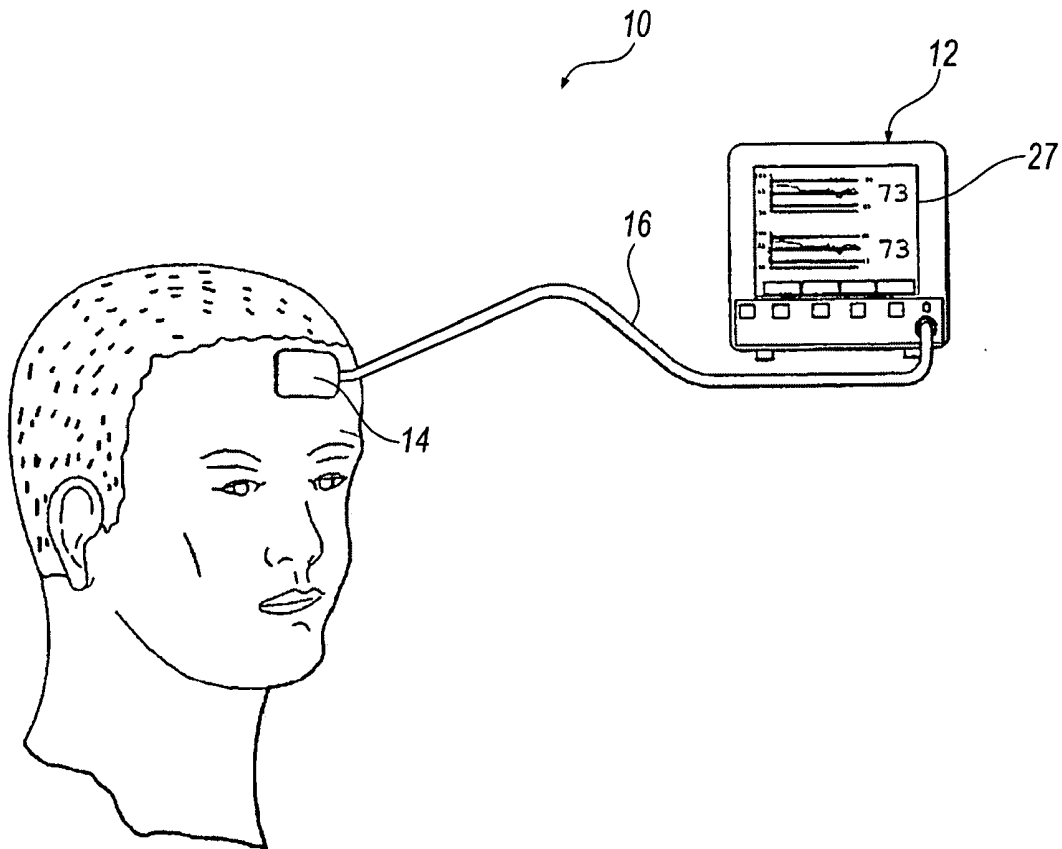

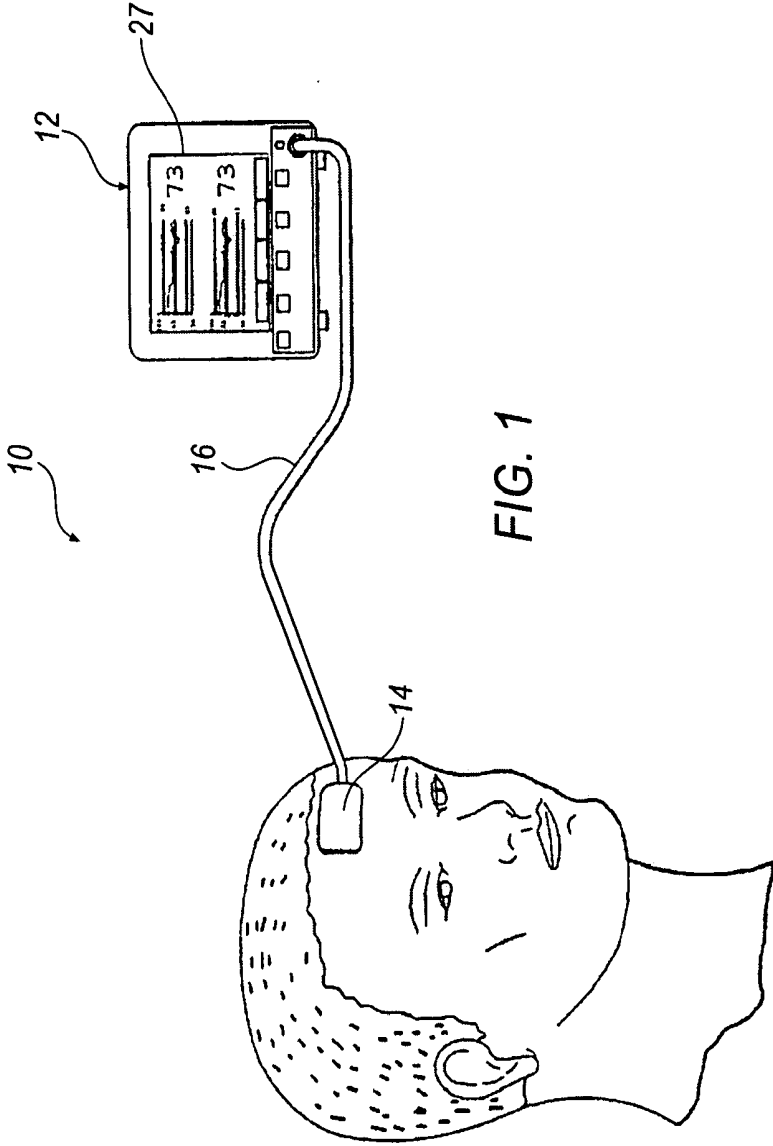
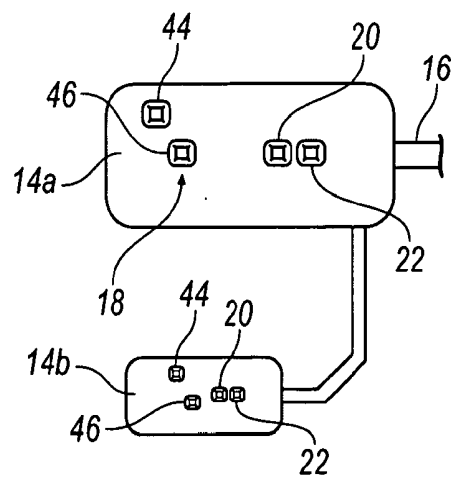
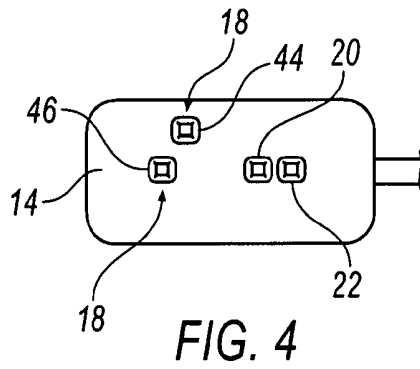
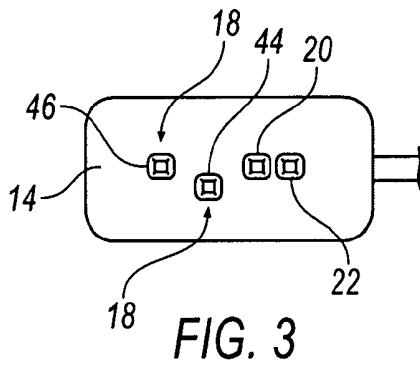
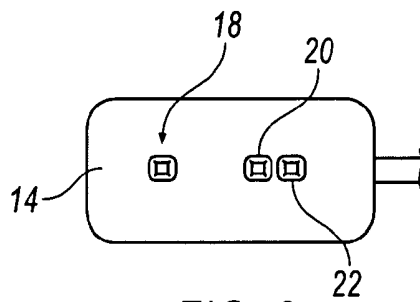

FIG. 1



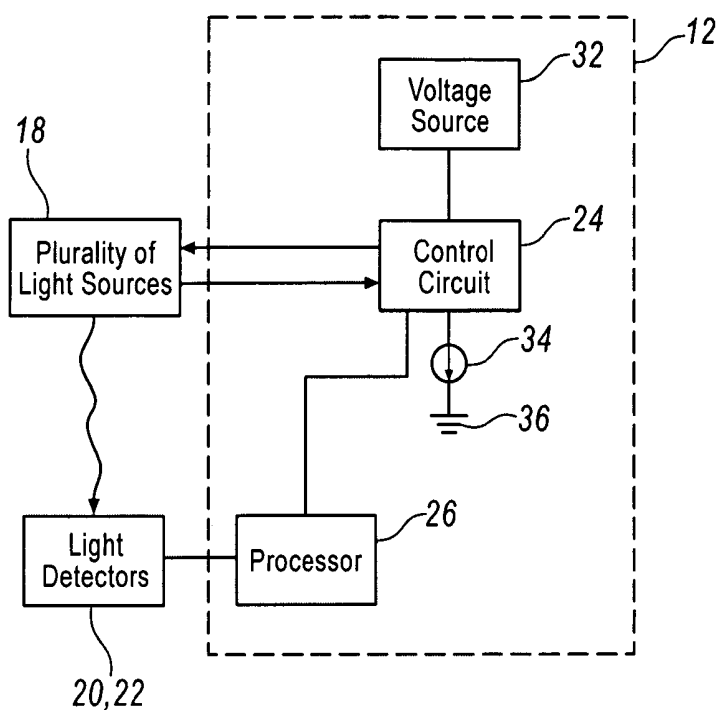

FIG. 6

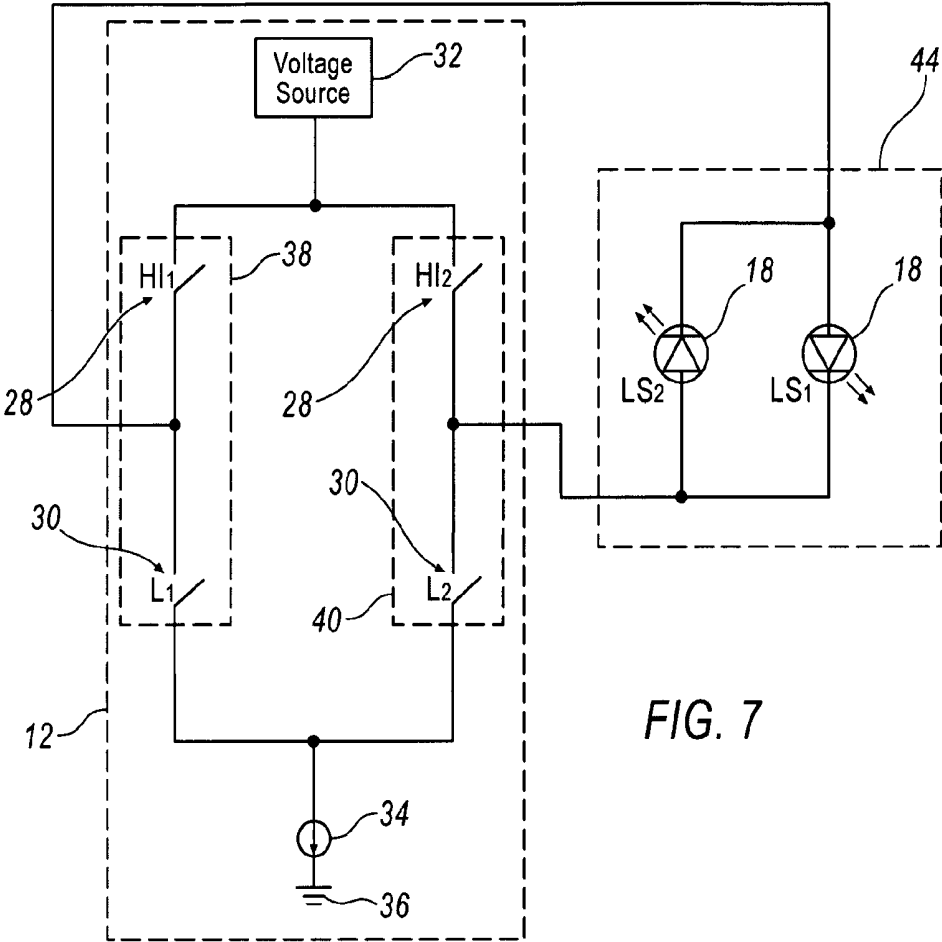

FIG. 7

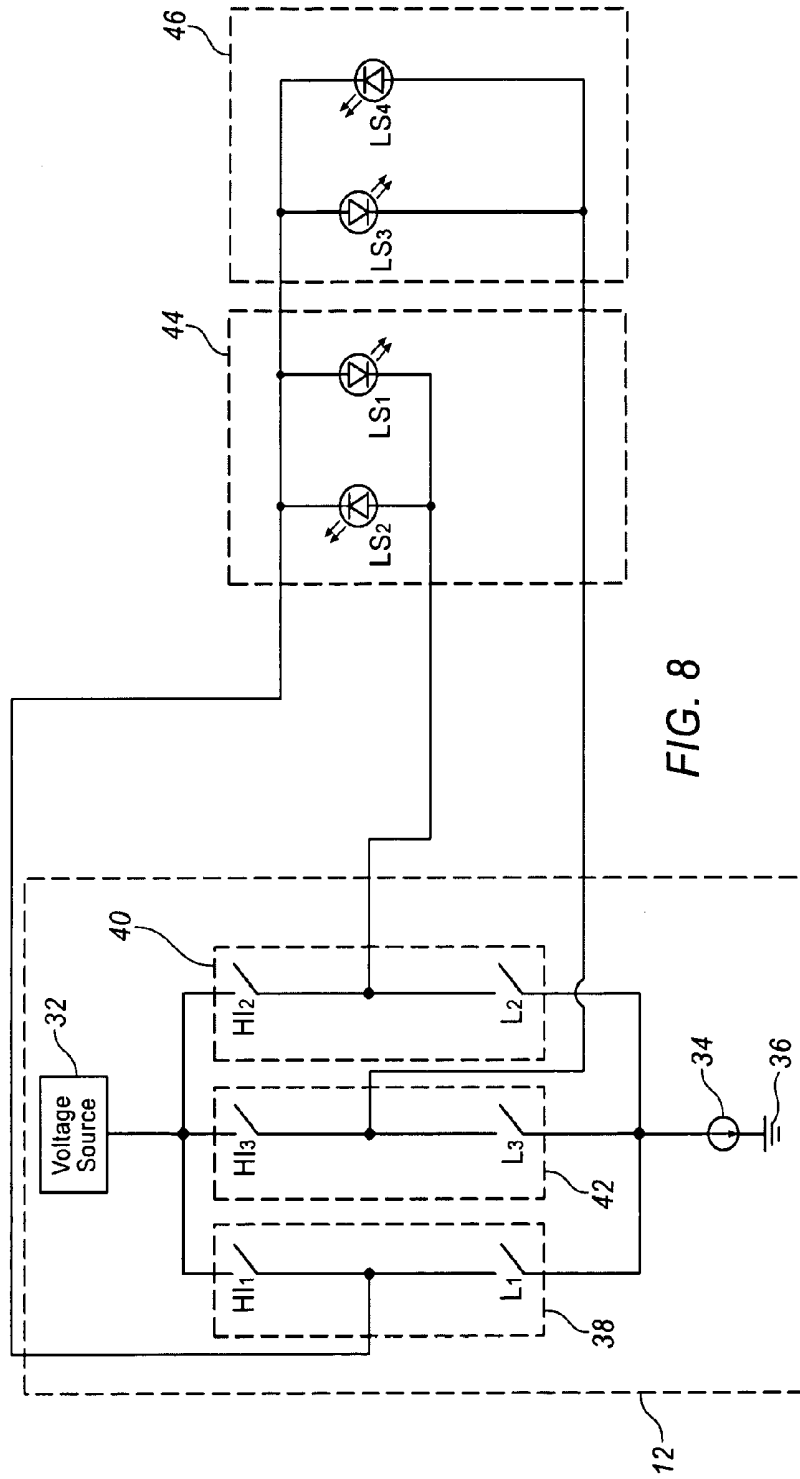

FIG. 8

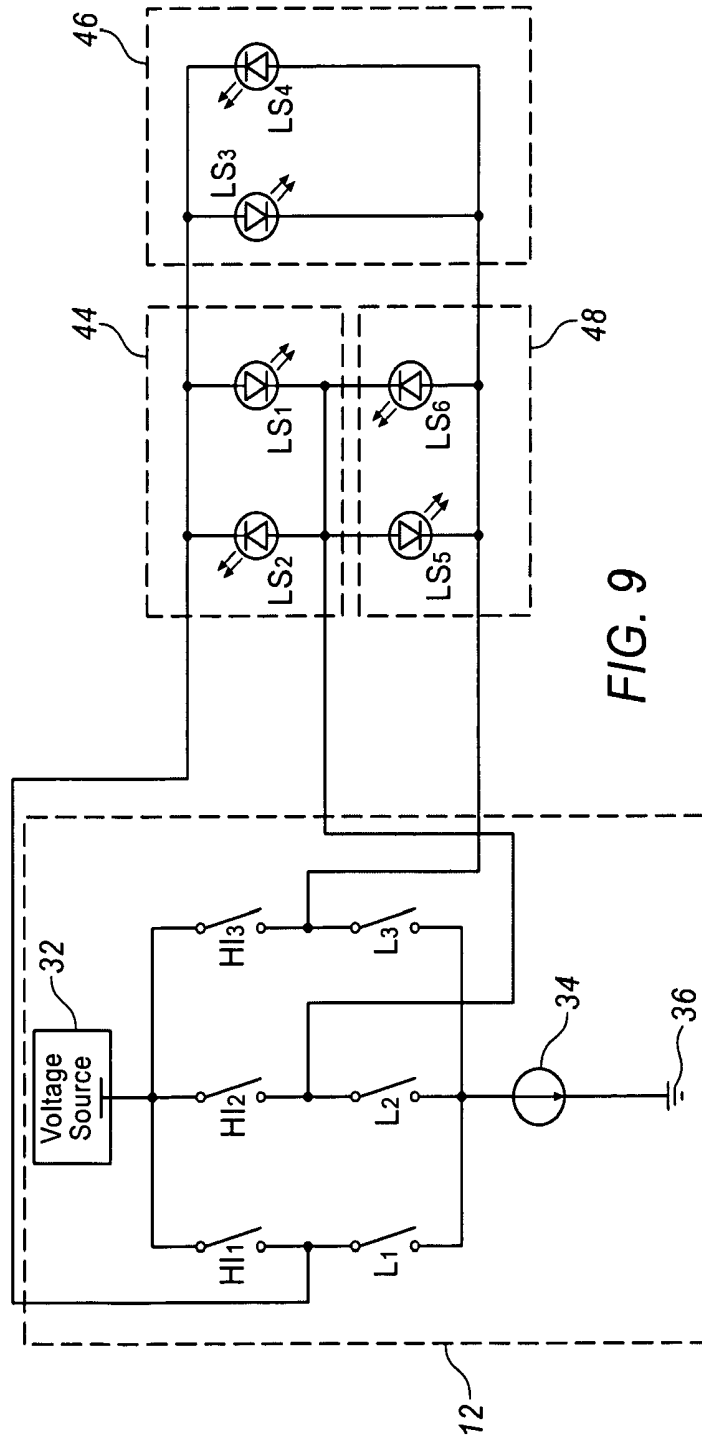

FIG. 9

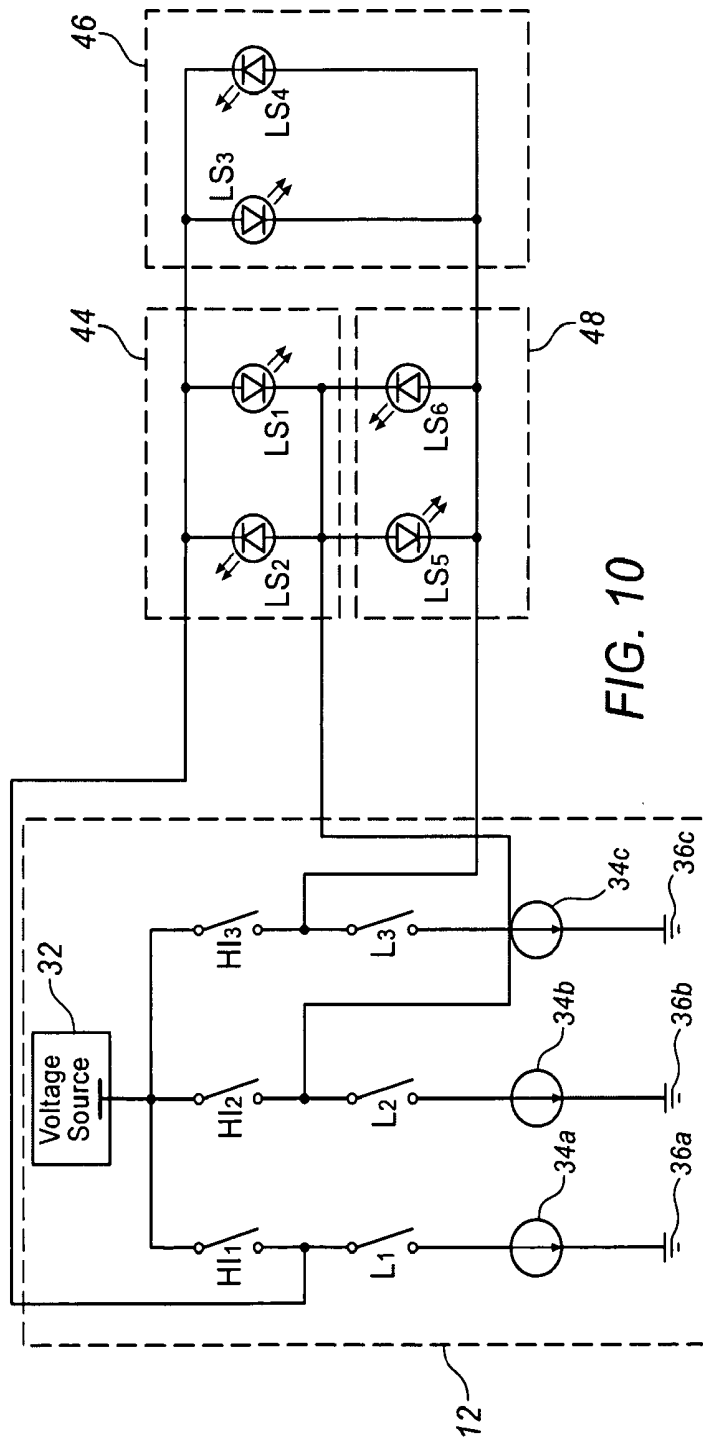

FIG. 10

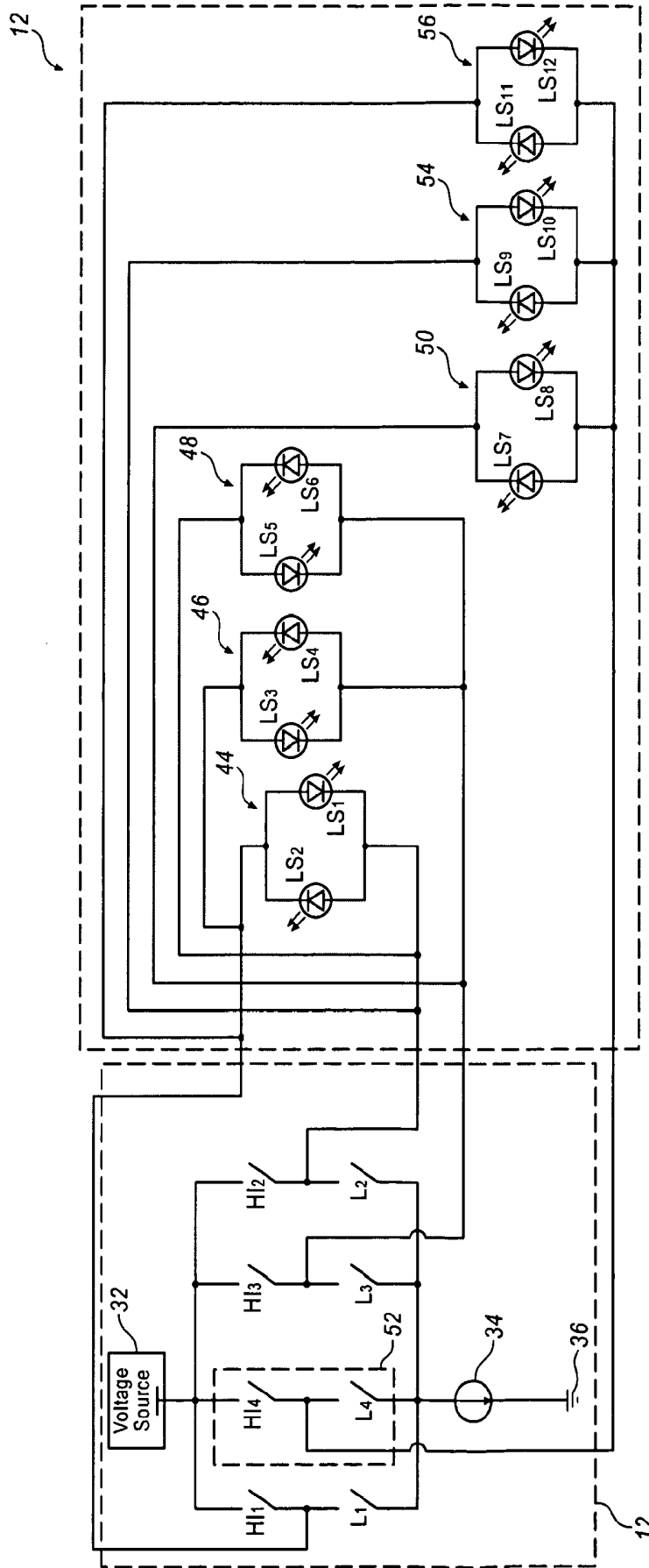

FIG. 11

PHYSIOLOGICAL SENSOR

CROSS-REFERENCE TO RELATED APPLICATIONS

[0001] This application is a continuation of U.S. application Ser. No. 13/755,432, filed Jan. 31, 2013, entitled "PHYSIOLOGICAL SENSOR", which is a continuation of U.S. application Ser. No. 11/963,174, filed Dec. 21, 2007, now U.S. Pat. No. 8,380,272, entitled "PHYSIOLOGICAL SENSOR", issued Feb. 19, 2013, which are incorporated herein by reference in their entirety.

BACKGROUND

[0002] To improve the accuracy of the measurement, or to enable the measurement of additional physiological characteristics, additional wavelengths of light can be used. This generally necessitates the addition of light sources requiring additional wires to carry the excitation potentials. Unfortunately, the addition of wires adds to the cost and complexity of the system. Moreover, monitoring systems are generally configured to work with sensor pads having a fixed number of wires. For example, if a monitoring system is configured to work with sensor pads having a three wire configuration, a sensor pad using additional light sources and having any more than three wires may not be compatible with the existing monitoring system.

[0003] One known method used to minimize the number of wires in a sensor pad when increasing the number of light sources includes having multiple light sources connected in a matrix of rows and columns of wires. The light sources in this configuration are activated by sequentially addressing the row and column of each light source with an excitation path. In this way, four wires provide connection and activation of four light sources. If pairs of light sources are connected in parallel, the same configuration of four wires can be used to connect and activate up to eight light sources. This configuration, however, requires a minimum of four wires and is limited to a maximum of eight light sources.

[0004] Accordingly, the embodiments described hereinafter were developed in light of these and other drawbacks associated with increasing the number of light sources in a physiological sensor without increasing the number of wires.

BRIEF DESCRIPTION OF THE DRAWINGS

[0005] FIG. 1 is a perspective view of an exemplary physiological sensor according to an embodiment;

[0006] FIG. 2 is a bottom view of a pad of the physiological sensor, according to an embodiment;

[0007] FIG. 3 is a bottom view of the physiological sensor according to another embodiment with multiple light source locations;

[0008] FIG. 4 is a bottom view of the physiological sensor according to third embodiment with multiple light source locations;

[0009] FIG. 5 is a bottom view of a physiological sensor having a plurality of sensing pads;

[0010] FIG. 6 is a block diagram illustrating an exemplary control scheme, according to an embodiment;

[0011] FIG. 7 is a diagram illustrating an exemplary control circuit and light assembly, according to an embodiment;

[0012] FIG. 8 is a diagram illustrating another exemplary control circuit and light assembly, according to an embodiment;

[0013] FIG. 9 is a diagram illustrating another exemplary control circuit and light assembly, according to an embodiment;

[0014] FIG. 10 is a diagram illustrating the exemplary control circuit and light assembly as set forth in FIG. 9 having multiple current sources; and

[0015] FIG. 11 is a diagram illustrating another exemplary control circuit and light assembly, according to an embodiment.

DETAILED DESCRIPTION

[0016] A physiological sensor that allows for an increased number of light sources without an increase in the number of wires is provided. Specifically, the physiological sensor can use four or six light sources in a three-wire configuration, or alternatively, up to twelve light sources in a four-wire configuration. In either embodiment, the physiological sensor includes one or more light source assemblies electrically connected to a monitoring system and in optical communication with at least one light detector. Each light source assembly includes at least one light source.

[0017] The arrangement of the light sources allows the physiological sensor to measure physiological characteristics of body tissue such as oxygen saturation or other various hemoglobin species with increased accuracy and without a significant increase in size or cost. The arrangement of the light sources may also measure concentrations of additional chromophores in tissue besides hemoglobin. The spatial relationship of the light sources relative to the light detector may enhance spatial resolution and provide values at different depths, which may help in organ oxygen delivery monitoring.

[0018] Moreover, because the physiological sensor maintains a three or four wire configuration, the physiological sensor may be used with pre-existing monitoring systems, thus making the physiological sensor described herein backwards compatible. It is to be understood that the physiological sensor may be configured to work with any number of wires since the number of light assemblies (each having two light sources) is related to the number of wires. Specifically, the number of light source assemblies can be calculated by the equation: $N_{LSA} = N_w * (N_w - 1) / 2$, wherein N_{LSA} is the number of light source assemblies and N_w is the number of wires.

[0019] FIG. 1 illustrates an exemplary physiological sensor system 10 that includes a monitoring system 12 connected to a sensor pad 14 through a cable 16. As best shown in FIG. 2, the sensor pad 14 includes a plurality of light sources 18 in optical communication with first and second light detectors 20, 22. It is to be appreciated that multiple light sources 18 may be disposed in multiple openings of the sensor pad 14. The plurality of light sources 18 may include any light source known in the art, including but not limited to, light emitting diodes, laser diodes or any combination thereof. Typically, the frequency of the light excitation and wavelength of the light source is dependent upon the application. For instance, in cerebral oximetry, pulse oximetry, or tissue oximetry applications, the light sources 18 may have a wavelength in the visible and/or infrared spectrum. For instance, the light sources 18 may have a wavelength between 600 nm and 1000 nm, including, but not limited to, a wavelength of 660 nm, 724 nm, 750 nm, 770 nm, 812 nm, 850 nm, 905 nm, or any combination thereof. It is to be understood that the light sources 18 may have other wavelengths to measure other physiological characteristics.

[0020] As shown in FIGS. 3 and 4, the plurality of light sources 18 may be mounted in two or more different physical locations on the sensor pad 14 or in openings in the pad 14. By adding additional light source assemblies when the physiological sensor system 10 is used as a cerebral oximeter sensor, the monitoring system 12 can obtain additional absorption spectra at additional wavelengths. The additional absorption spectra can help to better define the extinction curves for various blood and tissue chromophores, allowing more accurate determination of their relative concentrations. In one embodiment, each light source 18 is illuminated sequentially and independently, allowing measurement of light absorption at specific wavelengths by one or more of the light detectors 20, 22. Alternatively, two or more light sources 18 may be illuminated simultaneously to provide additional light output and an improved signal-to-noise ratio at specific wavelengths. This may be necessary because certain wavelengths of light do not penetrate as deeply into tissue as other wavelengths do. As will be discussed in greater detail below, illuminating several light sources 18 simultaneously may include multiple current sources. Alternatively, certain light sources may not have the same light output as others. Simultaneously illuminating two or more of these lower output light sources can increase the effective light output, improving signal-to-noise ratio and stability.

[0021] In another embodiment, the physiological sensor system 10 may be used for fractional oximetry to measure fractional oxygen saturation and additional hemoglobin species in deep tissue of the brain, other organs, skin, or in skeletal muscle tissue. By selecting wavelengths of light appropriately, additional fractional concentrations of other hemoglobin species such as carboxyhemoglobin and methemoglobin can be determined. Most noninvasive oximeters measure functional hemoglobin oxygen saturation, which is defined as the ratio of oxyhemoglobin to the unbound hemoglobin that is available for oxygen binding. As such, it does not measure or take into effect the proportion of hemoglobin that is bound to other compounds such as carbon monoxide (carboxyhemoglobin) or hydrogen sulfide (sulfhemoglobin). Additional species of hemoglobin such as methemoglobin, where the ferrous iron has been oxidized to ferric iron, are not measured either. By incorporating additional wavelengths of light, the effect of additional chromophores with unique extinction curves can be measured, enabling estimation of the fraction of each hemoglobin compound, or fractional saturation.

[0022] In yet another embodiment, some of the plurality of light sources 18 may be used for cerebral or tissue oximetry and others of the plurality of light sources 18 may be used for pulse oximetry to measure arterial blood hemoglobin oxygen saturation. This allows the physiological sensor system 10 to measure various physiological characteristics with the same sensor pad 14. In this embodiment, a first light source assembly 44 may use selected wavelengths of light and be located a sufficient distance from one of the detectors 20, 22 to measure cerebral oxygen saturation while a second light source assembly 46 may use wavelengths suited for measurement of arterial oxygen saturation using reflectance pulse oximetry and would therefore be located close to another of the light detectors 20, 22. Alternatively, the first light detector 20 may be used to measure arterial oxygen saturation based on the spatial relationship of the plurality of light sources 18. This embodiment also allows arterial saturation of deeper tissues to be measured because the depth of penetration of photons is

proportional to the separation distance between the light source 18 and the light detector 20, 22.

[0023] In yet another embodiment, the plurality of light sources 18 can be spatially arranged to increase the accuracy of the measurements. For instance, the first light source assembly 44 can have different wavelengths that penetrate less deeply into the body tissue than other light source assemblies. For instance, as shown in FIG. 3, placing the first light source assembly 44 closer to the light detector 20 and slightly offset from the first light source assembly 46 allows the first light source assembly 44 to penetrate into the body tissue shallower than the second light source assembly 46. Likewise, placing the second light source 46 further away from the light detector 20 and slightly offset from the first light source assembly 44 causes light generated by the second light source assembly 46 to penetrate deeper into the body tissue. Alternatively, as shown in FIG. 4, the first light source assembly 44 may be spaced away from the second light source assembly 46 and more offset from the second light source assembly 46 to achieve a similar result. In this embodiment, the ratios of the signals from each of the light detectors 20, 22 can be computed using both light source assemblies 44, 46.

[0024] In yet another embodiment, the physiological sensor system 10 may contain a plurality of sensor pads 14 and each sensor pad 14 may contain at least one light source assembly 44 and one light detector 20. This arrangement of the physiological sensor system 10 may be used to measure two physiological parameters including, but not limited to, cerebral blood saturation and arterial blood saturation. The cerebral measurement may require a low skin perfusion site on the forehead to reduce interference from extra-cranial signals. However, arterial blood oxygen saturation may require high skin perfusion. Thus, in one embodiment, for cerebral oximetry, the sensor pad 14 may be placed on the forehead directly below the hair line. On the other hand, for pulse oximetry, the sensor pad 14 may be placed on the forehead directly above the eyes. In this embodiment, a single sensor pad 14 may be inconvenient to use at least for an adult patient. Therefore, two sensor pads 14 may be used.

[0025] Referring now to FIG. 5, in one exemplary approach, the physiological sensor system 10 includes a first sensor pad 14A and a second sensor pad 14B. The first sensor pad 14A may be used, for instance, for tissue oximetry, and the second sensor pad 14B may be used, for instance, for pulse oximetry. The first sensor pad 14A may include the light source assemblies 44, 46, in optical communication with the first and second light detectors 20, 22. It is to be appreciated that the first sensor pad 14A may include any number of light source assemblies 44, 46 and any number of light detectors 20, 22. Likewise, the second sensor pad 14B may include the light source assemblies 44, 46, in optical communication with the first and second light detectors 20, 22. It is to be appreciated that the second sensor pad 14B may include any number of light source assemblies 44, 46 and any number of light detectors 20, 22.

[0026] Other cases where two or more sensor pads 14 may be used include measuring cerebral oxygenation from at least two sites of the brain, or measuring cerebral and tissue oxygenation simultaneously in infants. In this embodiment, the physiological sensor system 10 may include at least two sensor pads 14, each having at least two light detectors 20, 22 and at least two light source assemblies 42, 46. The light source assemblies 42, 46 may be connected as described above and excited sequentially in time.

[0027] As shown in FIG. 6, monitoring system 12 includes a control circuit 24 and a processor 26 in communication with the plurality of light sources 18 and light detectors 20, 22. The processor 26 is configured to receive signals from light detectors 20, 22 and converts the signals into data that indicates the physiological characteristics of the body tissue. Furthermore, the processor 26 controls the control circuit 24 as will be discussed in greater detail below. It is to be understood that the control circuit 24 may alternatively be controlled by a dedicated processor (not shown) other than the processor 26 shown in FIG. 6. The monitoring system 12 may output the data to a display 27 as shown in FIG. 1.

[0028] FIG. 7 illustrates an exemplary control circuit 24, which includes at least one high switch 28 and at least one low switch 30. As discussed in greater detail below, it is to be understood that the high switch 28 connects the light sources 18 to a higher potential than the low switch 30. The high switch 28 and the low switch 30 may be any switch known in the art, and even the same type of switch. For instance, the high switch 28 and the low switch 30 may be transistors. In one embodiment, the high switch 28 may be a PMOS type transistor and the low switch 30 may be an NMOS type transistor. The high switch 28 and the low switch 30 may be connected in an H-Bridge configuration.

[0029] The at least one high switch 28 and the at least one low switch 30 are controlled by the processor 26 in the monitoring system 12. In other words, the processor 26 opens and closes the at least one high switch 28 and the at least one low switch 30 of the control circuit 24 to activate a select combination of the plurality of light sources 18. The monitoring system 12 includes a voltage source 32 electrically connected to the control circuit 24 for providing voltage to the control circuit 24 and the plurality of light sources 18. In addition, the monitoring system 12 may further include a current source 34 that causes current to flow from the voltage source 32 to ground 36. The low switches 30 connect each of the plurality of light sources 18 to the current source 34. The current source 34 is connected to the ground 36 at a ground potential. It is to be understood that the low switches 30 may connect to the plurality of light sources 18 directly to the ground potential. Otherwise, in at least one embodiment, there is no structural or functional difference between the high switches 28 and the low switches 30.

[0030] The control circuit 24 may include any number of high switches 28 or low switches 30. For instance, as shown in FIG. 7, the control circuit 24 includes a first high switch HI1 in series with a first low switch L1, the combination of which defines a first switch pair 38. Likewise, the control circuit 24 includes a second high switch HI2 in series with a second low switch L2, the combination of which defines a second switch pair 40. It is to be understood that the control circuit 24 may include any number of high switches 28 and low switches 30 to define any number of switch pairs. For instance, referring to FIG. 8, the control circuit 24 may include a third high switch HI3 and a third low switch L3 in series with the third high switch HI3 to define a third switch pair 42. As shown in FIG. 8, the first switch pair 38 is in parallel with the second switch pair 40 and the third switch pair 42.

[0031] Each high switch 28 and each low switch 30 have an anode and a cathode. The anode of the high switch 28 directly or indirectly connects to the voltage source 32 and the cathode of the low switch 30 directly or indirectly connects to a lower potential (i.e., a ground potential 36 or the current source 34).

When the control circuit 24 includes multiple high switches 28, the anodes of each of the high switches 28 are electrically connected to one another. For example, referring to FIG. 7, the anode of the first high switch HI1 may be electrically connected to the anode of the second high switch HI2. Similarly, when the control circuit 24 includes multiple low switches 30, the cathodes of each of the low switches 30 may be electrically connected. Again referring to FIG. 7, the cathode of the first low switch L1 is electrically connected to the cathode of the second low switch L2.

[0032] In operation, the processor 26 closes one of the high switches 28 and one of the low switches 30 to activate one of the plurality of light sources 18. In one embodiment, each light source is connected to two switch pairs. The light source is powered by the voltage source 32 when the high switch 28 in one of the switch pairs is closed and the low switch 30 in another switch pair is closed, completing an electrical circuit. It is to be understood that multiple light sources may be illuminated by closing more than one high switch 28 and/or more than one low switch 30. However, closing the high switch 28 and the low switch 30 in the same switch pair will cause an electrical short, and the light source will not illuminate. In other words, the light source does not operate when the high switch 28 and the low switch 30 from the same switch pair are both closed. To prevent an electrical short, the processor 26 opens the low switch 30 in the switch pair when the high switch 28 in the switch pair is closed. Therefore, the light source is electrically connected to the high switch 28 in one switch pair and the low switch 30 in another switch pair. It is to be understood that both the high switch 28 and the low switch 30 may be open at the same time.

[0033] As shown in FIG. 7, the physiological sensor 10 includes a first light source assembly 44 that is defined by at least one of the plurality of light sources 18 and electrically connected to the control circuit 24. As shown, the first light source assembly 44 includes a first light source LS1 in parallel with a second light source LS2. As previously discussed, the first light source LS1 and the second light source LS2 may be light emitting diodes or laser diodes. Each of the first light source LS1 and the second light source LS2 have an anode and a cathode. The anode of the first light source LS1 is electrically connected to the cathode of the second light source LS2. In addition, the cathode of the first light source LS1 is electrically connected to the anode of the second light source LS2. Therefore, although disposed in parallel with the second light source LS2, the first light source LS1 has an opposite polarity to the second light source LS2. The first light source LS1 and the second light source LS2 are each electrically connected to at least two switch pairs. Specifically, the first light source LS1 is electrically connected to the first high switch HI1 and the second low switch L2, and the second light source LS2 is electrically connected to the second high switch HI2 and the first low switch L1. The first high switch HI1 is in series with the second low switch L2 when the first high switch HI1 and the second low switch L2 are closed. Likewise, the second high switch HI2 is in series with the first low switch L1 when the second high switch HI2 and the first low switch L1 are closed. In this embodiment, only one of the plurality of light sources 18 may be illuminated at any time since only one of the first high switch HI1 and the second high switch HI2 may be closed because closing both the first high switch HI1 and the first low switch L1 or the second high switch HI2 and the second low switch L2 would cause an electrical short. Therefore, the processor 26 opens

the first low switch L1 when the first high switch HI1 is closed. Likewise, the processor 26 opens the second low switch L2 when the second high switch HI2 is closed.

[0034] It is to be understood that the physiological sensor system 10 may include any number of light source assemblies. For instance, referring to FIG. 8, the system 10 further includes a second light source assembly 46 defined by at least one of the plurality of light sources 18 and electrically connected to the monitoring system 12. The second light source assembly 46 includes a third light source LS3 in parallel with a fourth light source LS4. Although disposed in parallel with the fourth light source LS4, the third light source LS3 has an opposite polarity than the fourth light source LS4. Each of the third light source LS3 and the fourth light source LS4 have an anode and a cathode. The anode of the third light source LS3 is electrically connected to the cathode of the fourth light source LS4. The cathode of the third light source LS3 is electrically connected to the anode of the fourth light source LS4. In one embodiment, as shown in FIG. 8, the anode of the third light source LS3 is also electrically connected to the anode of the first light source LS1 and the cathode of the second light source LS2. As in the previous embodiment, the first light source LS1 is electrically connected to the first high switch HI1 and the second low switch L2 and the second light source LS2 is electrically connected to the second high switch HI2 and the first low switch L1. In this embodiment, the third light source LS3 is electrically connected to the first high switch HI1 and the third low switch L3. The fourth light source LS4 is electrically connected to the third high switch HI3 and the first high switch HI1. Again, the third high switch HI3 is in series with the third low switch L3 to make up the third switch pair 42.

[0035] In this embodiment, it is possible for the processor 26 to illuminate more than one of the plurality of light sources 18 simultaneously. For instance, the processor 26 may close the first high switch HI1 and the second low switch L2 to illuminate the first light source LS1. The processor 26 may then close the third low switch L3 to illuminate the third light source LS3 since both the first light source LS1 and the third light source LS3 receive power from the voltage source 32 when the first high switch HI1 is closed. It is to be appreciated that the processor 26 may close the third low switch L3 at the same time as closing the second low switch L2 to illuminate the third light source LS3 simultaneously with the first light source LS1, or the processor 26 may close the third low switch L3 after closing the second low switch L2 to illuminate the third light source LS3 sequentially with the first light source LS1. Alternatively, the processor 26 may close the second high switch HI2 and the first low switch L1 to illuminate the second light source LS2, and by closing the third high switch HI3 while the second high switch HI2 and the first low switch L1 are closed, the processor 26 additionally illuminates the fourth light source LS4. Therefore, in this embodiment, the processor 26 may illuminate two of the plurality of light sources 18.

[0036] Referring now to FIG. 9, the physiological sensor system 10 further includes a third light source assembly 48 that includes a fifth light source LS5 in parallel with a sixth light source LS6. Although disposed in parallel with the sixth light source LS6, the fifth light source LS5 has an opposite polarity than the sixth light source LS6. Each of the fifth light source LS5 and the sixth light source LS6 have an anode and a cathode. The anode of the fifth light source LS5 is electrically connected to the cathode of the first light source LS1, the

anode of the second light source LS2, and the cathode of the sixth light source LS6. The cathode of the fifth light source LS5 is electrically connected to the cathode of the third light source LS3, the anode of the fourth light source LS4, and the anode of the sixth light source LS6. The anode of the sixth light source LS6 is electrically connected to the cathode of the third light source LS3 and the anode of the fourth light source LS4. The cathode of the sixth light source LS6 is electrically connected to the cathode of the first light source LS1 and the anode of the second light source LS2. As in the previous embodiment, the processor 26 may illuminate more than one of the plurality of light sources 18 simultaneously. For instance, the processor 26 may close the first high switch HI1 and the second low switch L2 to illuminate the first light source LS1. At the same time, the processor 26 may close the third low switch L3 to illuminate the third light source LS3. Therefore, the processor 26 may illuminate more than one of the plurality of light sources 18 simultaneously.

[0037] In one exemplary embodiment, to illuminate more than one of the plurality of light sources 18 simultaneously, the physiological sensor system 10 may include more than one current sources 34. Referring now to FIG. 10, the physiological sensor 10 includes a first current source 34A electrically connected to the first low switch L1, a second current source 34B electrically connected to the second low switch L2, and a third current source 34C electrically connected to the third low switch L3. The current sources 34A, 34B, and 34C help to ensure that the light sources 18 maintain a minimum amount of brightness when the light sources 18 are simultaneously illuminated.

[0038] Again, it is to be understood that the physiological sensor system 10 may include any number of light source assemblies. For instance, referring to FIG. 11, the physiological sensor system 10 further includes a fourth light source assembly 50, a fifth light source assembly 54, and a sixth light source assembly 56. In addition, the control circuit 24 includes a fourth switch pair 52 having a fourth high switch HI4 in series with a fourth low switch L4. The fourth light source assembly 50 includes a seventh light source LS7 in parallel with an eighth light source LS8. The seventh light source LS7 and the eighth light source LS8 each have an anode and a cathode. The anode of the seventh light source LS7 is electrically connected to the fourth high switch HI4 and the cathode of the seventh light source LS7 is electrically connected to the third ground 36 source. The anode of the eighth light source LS8 is electrically connected to the third high switch HI3 and the cathode of the eighth light source LS8 is electrically connected to the fourth low switch L4. The fifth light source assembly 54 includes a ninth light source LS9 in parallel with a tenth light source LS10. The ninth light source LS9 and the tenth light source LS10 each have an anode and a cathode. The anode of the ninth light source LS9 is electrically connected to the fourth high switch HI4 and the cathode of the ninth light source LS9 is electrically connected to the second low switch L2. The anode of the tenth light source LS10 is electrically connected to the second high switch HI2 and the cathode of the tenth light source LS10 is electrically connected to the fourth low switch L4. The sixth light source assembly 56 includes an eleventh light source LS11 in parallel with a twelfth light source LS12. The eleventh light source LS11 and the twelfth light source LS12 each have an anode and a cathode. The anode of the eleventh light source LS11 is electrically connected to the fourth high switch HI4 and the cathode of the eleventh light source LS11

electrically connected to the first low switch L1. The anode of the twelfth light source LS12 is electrically connected to the first high switch HI1 and the cathode of the twelfth light source LS12 is electrically connected to the fourth low switch L4. As in the previous embodiments, the processor 26 may illuminate one or more of the plurality of light sources 18. For instance, the processor 26 may close the first high switch HI1, the second low switch L2, and the fourth low switch L4 to illuminate the first light source LS1, the third light source LS3, and the twelfth light source LS12. Alternatively, the processor 26 may close the first high switch HI1, the third high switch HI3, the fourth high switch HI4, and the second low switch L2 to illuminate the first light source LS1, the sixth light source LS6, and the ninth light source LS9.

[0039] It is to be understood that the physiological sensor system 10 may include any number of light source assemblies, each including any number of light sources 18. Also, the processor 26 may close different combinations of the high switches 28 and the low switches 30 to illuminate alternative combinations of the plurality of light sources 18.

[0040] It is to be understood that the above description is intended to be illustrative and not restrictive. Many alternative approaches or applications other than the examples provided would be apparent to those of skill in the art upon reading the above description. The scope of the invention should be determined, not with reference to the above description, but should instead be determined with reference to the appended claims, along with the full scope of equivalents to which such claims are entitled. It is anticipated and intended that future developments will occur in the arts discussed herein, and that the disclosed systems and methods will be incorporated into such future examples. In sum, it should be understood that the invention is capable of modification and variation and is limited only by the following claims.

[0041] The present embodiments have been particularly shown and described, which are merely illustrative of the best modes. It should be understood by those skilled in the art that various alternatives to the embodiments described herein may be employed in practicing the claims without departing from the spirit and scope as defined in the following claims. It is intended that the following claims define the scope of the invention and that the method and apparatus within the scope of these claims and their equivalents be covered thereby. This description should be understood to include all novel and non-obvious combinations of elements described herein, and claims may be presented in this or a later application to any novel and non-obvious combination of these elements. Moreover, the foregoing embodiments are illustrative, and no single feature or element is essential to all possible combinations that may be claimed in this or a later application.

[0042] All terms used in the claims are intended to be given their broadest reasonable constructions and their ordinary meanings as understood by those skilled in the art unless an explicit indication to the contrary is made herein. In particular, use of the singular articles such as "a," "the," "said," etc. should be read to recite one or more of the indicated elements unless a claim recites an explicit limitation to the contrary.

1. A system, comprising:

a first light source assembly disposed on a sensor pad at a first location, wherein the first light source assembly comprises a first plurality of light sources configured to emit light into a body tissue;

a first detector spaced a first distance apart from the first light source assembly on the sensor pad, wherein the first detector is configured to detect the emitted light;

a second detector spaced a second distance apart from the first light source assembly on the sensor pad along an imaginary axis connecting the first light source assembly and the first detector, wherein the second detector is configured to detect the emitted light, and wherein the first light source assembly, the first detector, and the second detector are configured for cerebral or tissue oximetry; and

a second light source assembly disposed on the sensor pad at a second location, wherein the second location is offset from the imaginary axis and closer to the first and second detectors than the first location, wherein the second light source assembly comprises a second plurality of light sources configured to emit light into the body tissue, and wherein the second light source assembly and one or both of the second detectors are configured for pulse oximetry.

2. The system of claim 1, wherein the first light source assembly is configured to emit one or more wavelengths of light suitable for cerebral or tissue oximetry deeper into the body tissue than the second light source assembly.

3. The system of claim 1, wherein the imaginary axis intersects a sensor cable coupled to the sensor pad.

4. The system of claim 1, wherein the second location of the second light source assembly is above the imaginary axis and closer to a first edge of the sensor pad than the first light source assembly.

5. The system of claim 1, wherein a distance between the first and second detectors is less than the first distance.

6. The system of claim 3, wherein the sensor cable couples the first and second light source assemblies and the first and second detectors to a monitoring device.

7. The system of claim 6, wherein the monitoring device comprises a plurality of current sources, and wherein at least one current source of the plurality of current sources is electrically coupled to at least one light source of the first and second plurality of light sources.

8. The system of claim 6, wherein the monitoring device is configured to activate one or more light sources of the first and second plurality of light sources.

9. The system of claim 1, wherein at least one of the first light source assembly and the second light source assembly comprises a light emitting diode and a laser diode.

10. A sensor, comprising:

at least one sensor pad;

a first light source assembly disposed on the sensor pad at a first location, wherein the first light source assembly comprises a first plurality of light sources configured to emit light into a body tissue;

a first detector spaced a first distance apart from the first light source assembly on the sensor pad, wherein the first detector is configured to detect the emitted light;

a second detector spaced a second distance from the first light source assembly on the sensor pad, wherein the second distance is greater than the first distance, and wherein the second detector is configured to detect the emitted light; and

a second light source assembly disposed on the sensor pad at a second location, wherein the second location is farther from the first and second detectors than the first location, and wherein the second location is offset from

an imaginary axis intersecting the first location, the first detector, and the second detector, and wherein the second light source assembly comprises a second plurality of light sources configured to emit light into the body tissue.

11. The sensor of claim 10, wherein the first light source assembly, the first detector, and the second detector are configured for cerebral or tissue oximetry.

12. The sensor of claim 10, wherein the second light source assembly and one or both of the first detector and the second detector are configured for pulse oximetry.

13. The sensor of claim 10, wherein the first light source assembly emits one or more wavelengths of light deeper into the tissue body than the second light source assembly.

14. The sensor of claim 10, wherein the imaginary axis is parallel to a largest edge of the sensor pad.

15. The sensor of claim 10, wherein at least one of the first light source assembly and the second light source assembly comprise a light emitting diode and a laser diode.

16. The sensor of claim 10, wherein the sensor pad is configured to be applied to a forehead of a patient.

17. A method, comprising:

driving one or more light sources of a first light source assembly disposed on a sensor pad at a first location, wherein the one or more light sources of the first light source assembly are configured to emit light into a body tissue;

receiving one or more first signals from one of a first detector or a second detector disposed on the sensor pad, wherein the one or more first signals are related to an amount of light detected by the first or second detector from the first light source assembly, and wherein the one or more first signals are associated with pulse oximetry monitoring;

driving one or more light sources of a second light source assembly disposed on a sensor pad at a second location, wherein the second location is farther from the first and second detectors than the first light source assembly, and wherein the one or more light sources of the second light source assembly are configured to emit light into a body tissue;

receiving one or more second signals from the first detector and the second detector, wherein the one or more second signals are related to an amount of light detected from the second light source assembly, and wherein the one or more second signals are associated with cerebral or tissue oximetry monitoring.

18. The method of claim 17, comprising determining an arterial blood saturation of the body tissue based at least in part on the one or more first signals.

19. The method of claim 17, comprising determining a cerebral blood saturation of the body tissue based at least in part on the one or more second signals.

20. The method of claim 17, comprising driving the one or more light sources of the first and second light source assemblies sequentially.

* * * * *

专利名称(译)	生理传感器		
公开(公告)号	US20150216461A1	公开(公告)日	2015-08-06
申请号	US14/688618	申请日	2015-04-16
[标]申请(专利权)人(译)	柯惠有限合伙公司		
申请(专利权)人(译)	COVIDIEN LP		
当前申请(专利权)人(译)	COVIDIEN LP		
[标]发明人	BARRETT BRUCE J GONOPOLSKY OLEG WIDMAN RONALD A SCHEUING RICK		
发明人	BARRETT, BRUCE J. GONOPOLSKY, OLEG WIDMAN, RONALD A. SCHEUING, RICK		
IPC分类号	A61B5/1455 A61B5/00 A61B5/024		
CPC分类号	A61B5/14553 A61B2562/0233 A61B2562/0242 A61B5/6814 A61B5/0059 A61B5/02427 A61B2562/046		
外部链接	Espacenet USPTO		

摘要(译)

提供了一种用于测量身体组织的生理特征的传感器。生理传感器包括第一光源组件，第一光源组件具有与第二光源平行的第一光源。第一光源和第二光源中的每一个都具有阳极和阴极。第二光源组件包括与第四光源平行的第三光源。第三光源和第四光源中的每一个都具有阳极和阴极。第一光源的阳极电连接到第二光源的阴极，所述第三光源的阳极和所述第四光源的阴极。第三光源的阳极电连接到第四光源的阴极。

