



US010568586B2

(12) **United States Patent**
Begin et al.

(10) **Patent No.:** **US 10,568,586 B2**
(45) **Date of Patent:** **Feb. 25, 2020**

(54) **SYSTEMS FOR INDICATING PARAMETERS IN AN IMAGING DATA SET AND METHODS OF USE**

A61B 5/066 (2013.01); *A61B 5/746* (2013.01);
A61B 5/7455 (2013.01); (2013.01);

(Continued)

(71) Applicant: **VOLCANO CORPORATION**, San Diego, CA (US)

(58) **Field of Classification Search**

CPC *A61B 8/5223*; *A61B 5/7435*; *A61B 8/12*; *A61B 8/0841*; *A61B 5/0035*; *A61B 6/504*; *A61B 5/0095*; *A61B 6/12*; *A61B 5/02007*; *A61B 5/0263*; *A61B 5/0261*; *A61B 5/021*; *A61B 5/7475*; *A61B 5/746*; *A61B 5/7455*;

(Continued)

(72) Inventors: **Elizabeth Begin**, Billerica, MA (US); **Joseph Burnett**, Carlsbad, CA (US); **Nathaniel J. Kemp**, Concord, MA (US); **Anuja Nair**, Bedford, MA (US); **Timothy K. Glynn**, San Marcos, CA (US); **Jason Sproul**, Watertown, MA (US)

(56) **References Cited**

U.S. PATENT DOCUMENTS

3,301,258 A 1/1967 Werner
3,617,880 A 11/1971 Cormack et al.
(Continued)

(73) Assignee: **VOLCANO CORPORATION**, San Diego, CA (US)

(*) Notice: Subject to any disclaimer, the term of this patent is extended or adjusted under 35 U.S.C. 154(b) by 0 days.

FOREIGN PATENT DOCUMENTS

(21) Appl. No.: **14/044,987**

EP 1041373 A2 10/2000
EP 01172637 A1 1/2002
(Continued)

(22) Filed: **Oct. 3, 2013**

(65) **Prior Publication Data**

US 2014/0100442 A1 Apr. 10, 2014

OTHER PUBLICATIONS

Abdi et al., 2010, Principal component analysis, Wiley Interdisciplinary Reviews: Computational Statistics 2:433-459.

(Continued)

Related U.S. Application Data

(60) Provisional application No. 61/710,419, filed on Oct. 5, 2012.

Primary Examiner — Bo Joseph Peng

(51) **Int. Cl.**
A61B 5/00 (2006.01)
A61B 8/12 (2006.01)

(Continued)

(57) **ABSTRACT**

Systems and methods for aiding users in viewing, assessing and analyzing images, especially images of lumens and medical devices contained within the lumens. Systems and methods for interacting with images of lumens and medical devices, for example through a graphical user interface.

(52) **U.S. Cl.**
CPC *A61B 5/7435* (2013.01); *A61B 5/0035* (2013.01); *A61B 5/0095* (2013.01); *A61B 5/021* (2013.01); *A61B 5/02007* (2013.01);

22 Claims, 24 Drawing Sheets

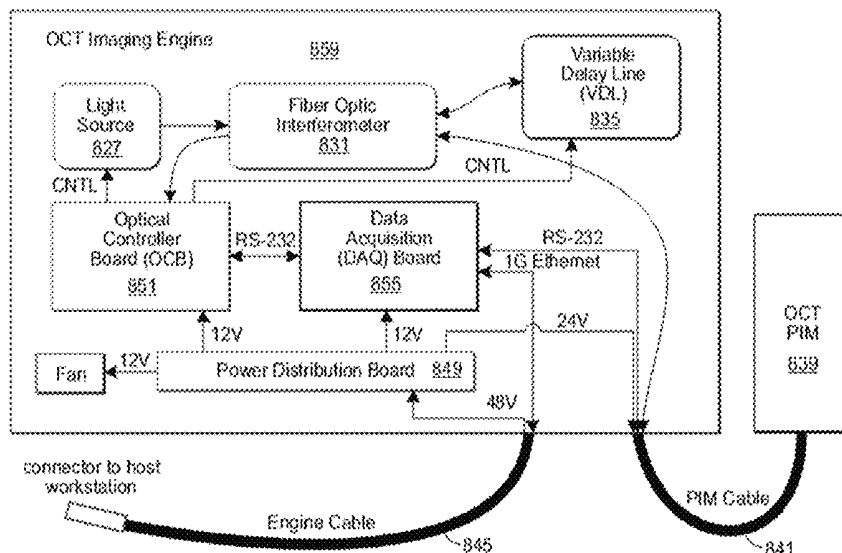

(56)

References Cited

U.S. PATENT DOCUMENTS

5,512,044	A	4/1996	Duer	6,141,089	A	10/2000	Thoma et al.
5,514,128	A	5/1996	Hillsman et al.	6,146,328	A	11/2000	Chiao et al.
5,529,674	A	6/1996	Hedgcoth	6,148,095	A	11/2000	Prause et al.
5,541,730	A	7/1996	Chaney	6,151,433	A	11/2000	Dower et al.
5,546,717	A	8/1996	Penczak et al.	6,152,877	A	11/2000	Masters
5,546,948	A	8/1996	Hamm et al.	6,152,878	A	11/2000	Nachtomy et al.
5,565,332	A	10/1996	Hoogenboom et al.	6,159,225	A	12/2000	Makower
5,573,520	A	11/1996	Schwartz et al.	6,165,127	A	12/2000	Crowley
5,581,638	A	12/1996	Givens et al.	6,176,842	B1	1/2001	Tachibana et al.
5,586,054	A	12/1996	Jensen et al.	6,179,809	B1	1/2001	Khairkahan et al.
5,592,939	A	1/1997	Martinelli	6,186,949	B1	2/2001	Hatfield et al.
5,596,079	A	1/1997	Smith et al.	6,190,353	B1	2/2001	Makower et al.
5,598,844	A	2/1997	Diaz et al.	6,200,266	B1	3/2001	Shokrollahi et al.
5,609,606	A	3/1997	O'Boyle	6,200,268	B1	3/2001	Vince et al.
5,630,806	A	5/1997	Inagaki et al.	6,203,537	B1	3/2001	Adrian
5,651,366	A	7/1997	Liang et al.	6,208,415	B1	3/2001	De Boer et al.
5,660,180	A	8/1997	Malinowski et al.	6,210,332	B1	4/2001	Chiao et al.
5,667,499	A	9/1997	Welch et al.	6,210,339	B1	4/2001	Kiepen et al.
5,667,521	A	9/1997	Keown	6,212,308	B1	4/2001	Donald
5,672,877	A	9/1997	Liebig et al.	6,231,518	B1	5/2001	Grabek et al.
5,674,232	A	10/1997	Halliburton	6,245,066	B1	6/2001	Morgan et al.
5,693,015	A	12/1997	Walker et al.	6,249,076	B1	6/2001	Madden et al.
5,713,848	A	2/1998	Dubrul et al.	6,254,543	B1	7/2001	Grunwald et al.
5,745,634	A	4/1998	Garrett et al.	6,256,090	B1	7/2001	Chen et al.
5,771,895	A	6/1998	Slager	6,258,052	B1	7/2001	Milo
5,779,731	A	7/1998	Leavitt	6,261,246	B1	7/2001	Pantages et al.
5,780,958	A	7/1998	Strugach et al.	6,275,628	B1	8/2001	Jones et al.
5,798,521	A	8/1998	Froggatt	6,283,921	B1	9/2001	Nix et al.
5,800,450	A	9/1998	Lary et al.	6,283,951	B1	9/2001	Flaherty et al.
5,803,083	A	9/1998	Buck et al.	6,295,308	B1	9/2001	Zah
5,814,061	A	9/1998	Osborne et al.	6,299,622	B1	10/2001	Snow et al.
5,817,025	A	10/1998	Alekseev et al.	6,312,384	B1	11/2001	Chiao
5,820,594	A	10/1998	Fontirroche et al.	6,325,797	B1	12/2001	Stewart et al.
5,824,520	A	10/1998	Mulligan-Keoh	6,328,696	B1	12/2001	Fraser
5,827,313	A	10/1998	Ream	6,343,168	B1	1/2002	Murphy et al.
5,830,222	A	11/1998	Makower	6,343,178	B1	1/2002	Burns et al.
5,848,121	A	12/1998	Gupta et al.	6,350,240	B1	2/2002	Song et al.
5,851,464	A	12/1998	Davila et al.	6,364,841	B1	4/2002	White et al.
5,857,974	A	1/1999	Eberle et al.	6,366,722	B1	4/2002	Murphy et al.
5,872,829	A	2/1999	Wischmann et al.	6,367,984	B1	4/2002	Stephenson et al.
5,873,835	A	2/1999	Hastings et al.	6,373,970	B1	4/2002	Dong et al.
5,882,722	A	3/1999	Kydd	6,375,615	B1	4/2002	Flaherty et al.
5,912,764	A	6/1999	Togino	6,375,618	B1	4/2002	Chiao et al.
5,916,194	A	6/1999	Jacobsen et al.	6,375,628	B1	4/2002	Zadno-Azizi et al.
5,921,931	A	7/1999	O'Donnell et al.	6,376,830	B1	4/2002	Froggatt et al.
5,925,055	A	7/1999	Adrian et al.	6,379,352	B1	4/2002	Reynolds et al.
5,949,929	A	9/1999	Hamm	6,381,350	B1	4/2002	Klingensmith et al.
5,951,586	A	9/1999	Berg et al.	6,387,124	B1	5/2002	Buscemi et al.
5,974,521	A	10/1999	Akerib	6,396,976	B1	5/2002	Little et al.
5,976,120	A	11/1999	Chow et al.	6,398,792	B1	6/2002	O'Connor
5,978,391	A	11/1999	Das et al.	6,417,948	B1	7/2002	Chowdhury et al.
5,997,523	A	12/1999	Jang	6,419,644	B1	7/2002	White et al.
6,021,240	A	2/2000	Murphy et al.	6,421,164	B2	7/2002	Tearney et al.
6,022,319	A	2/2000	Willard et al.	6,423,012	B1	7/2002	Kato et al.
6,031,071	A	2/2000	Mandeville et al.	6,426,796	B1	7/2002	Pulliam et al.
6,036,889	A	3/2000	Kydd	6,428,041	B1	8/2002	Wohllebe et al.
6,043,883	A	3/2000	Leckel et al.	6,428,498	B2	8/2002	Uflacker
6,050,949	A	4/2000	White et al.	6,429,421	B1	8/2002	Meller et al.
6,059,738	A	5/2000	Stoltze et al.	6,440,077	B1	8/2002	Jung et al.
6,068,638	A	5/2000	Makower	6,443,903	B1	9/2002	White et al.
6,074,362	A	6/2000	Jang et al.	6,450,964	B1	9/2002	Webler
6,078,831	A	6/2000	Belef et al.	6,457,365	B1	10/2002	Stephens et al.
6,080,109	A	6/2000	Baker et al.	6,459,844	B1	10/2002	Pan
6,091,496	A	7/2000	Hill	6,468,290	B1	10/2002	Weldon et al.
6,094,591	A	7/2000	Foltz et al.	6,475,149	B1	11/2002	Sumanaweera
6,095,976	A	8/2000	Nachtomy et al.	6,480,285	B1	11/2002	Hill
6,097,755	A	8/2000	Guenther, Jr. et al.	6,491,631	B2	12/2002	Chiao et al.
6,099,471	A	8/2000	Torp et al.	6,491,636	B2	12/2002	Chenal et al.
6,099,549	A	8/2000	Bosma et al.	6,501,551	B1	12/2002	Tearney et al.
6,102,938	A	8/2000	Evans et al.	6,504,286	B1	1/2003	Porat et al.
6,106,476	A	8/2000	Corl et al.	6,508,824	B1	1/2003	Flaherty et al.
6,120,445	A	9/2000	Grunwald	6,514,237	B1	2/2003	Maseda
6,123,673	A	9/2000	Eberle et al.	6,520,269	B2	2/2003	Geiger et al.
6,134,003	A	10/2000	Tearney et al.	6,520,677	B2	2/2003	Iizuka
6,139,510	A	10/2000	Palermo	6,535,764	B2	3/2003	Imran et al.
				6,538,778	B1	3/2003	Leckel et al.
				6,544,217	B1	4/2003	Gulachenski
				6,544,230	B1	4/2003	Flaherty et al.
				6,545,760	B1	4/2003	Froggatt et al.

(56)

References Cited

U.S. PATENT DOCUMENTS

6,546,272	B1	4/2003	MacKinnon et al.	6,949,094	B2	9/2005	Yaron
6,551,250	B2	4/2003	Khalil	6,952,603	B2	10/2005	Gerber et al.
6,566,648	B1	5/2003	Froggatt	6,954,737	B2	10/2005	Kalantar et al.
6,570,894	B2	5/2003	Anderson	6,958,042	B2	10/2005	Honda
6,572,555	B2	6/2003	White et al.	6,961,123	B1	11/2005	Wang et al.
6,579,311	B1	6/2003	Makower	6,966,891	B2	11/2005	Ookubo et al.
6,584,335	B1	6/2003	Haar et al.	6,969,293	B2	11/2005	Thai
6,592,612	B1	7/2003	Samson et al.	6,969,395	B2	11/2005	Eskuri
6,594,448	B2	7/2003	Herman et al.	6,985,234	B2	1/2006	Anderson
6,602,241	B2	8/2003	Makower et al.	7,004,963	B2	2/2006	Wang et al.
6,611,322	B1	8/2003	Nakayama et al.	7,006,231	B2	2/2006	Ostrovsky et al.
6,611,720	B2	8/2003	Hata et al.	7,010,458	B2	3/2006	Wilt
6,612,992	B1	9/2003	Hossack et al.	7,024,025	B2	4/2006	Sathyanarayana
6,615,062	B2	9/2003	Ryan et al.	7,027,211	B1	4/2006	Ruffa
6,615,072	B1	9/2003	Izzatt et al.	7,027,743	B1	4/2006	Tucker et al.
6,621,562	B2	9/2003	Durston	7,033,347	B2	4/2006	Appling
6,631,284	B2	10/2003	Nutt et al.	7,035,484	B2	4/2006	Silberberg et al.
6,638,227	B2	10/2003	Bae	7,037,269	B2	5/2006	Nix et al.
6,645,152	B1	11/2003	Jung et al.	7,042,573	B2	5/2006	Froggatt
6,646,745	B2	11/2003	Verma et al.	7,044,915	B2	5/2006	White et al.
6,655,386	B1	12/2003	Makower et al.	7,044,964	B2	5/2006	Jang et al.
6,659,957	B1	12/2003	Vardi et al.	7,048,711	B2	5/2006	Rosenman et al.
6,660,024	B1	12/2003	Flaherty et al.	7,049,306	B2	5/2006	Konradi et al.
6,663,565	B2	12/2003	Kawagishi et al.	7,058,239	B2	6/2006	Singh et al.
6,665,456	B2	12/2003	Dave et al.	7,060,033	B2	6/2006	White et al.
6,669,716	B1	12/2003	Gilson et al.	7,060,421	B2	6/2006	Naundorf et al.
6,671,055	B1	12/2003	Wavering et al.	7,063,679	B2	6/2006	Maguire et al.
6,673,015	B1	1/2004	Glover et al.	7,068,852	B2	6/2006	Braica
6,673,064	B1	1/2004	Rentrop	7,074,188	B2	7/2006	Nair et al.
6,685,648	B2	2/2004	Flaherty et al.	7,095,493	B2	8/2006	Harres
6,689,056	B1	2/2004	Kilcoyne et al.	7,110,119	B2	9/2006	Maestle
6,689,144	B2	2/2004	Gerberding	7,113,875	B2	9/2006	Terashima et al.
6,696,173	B1	2/2004	Naundorf et al.	7,123,777	B2	10/2006	Rondinelli et al.
6,701,044	B2	3/2004	Arbore et al.	7,130,054	B2	10/2006	Ostrovsky et al.
6,701,176	B1	3/2004	Halperin et al.	7,139,440	B2	11/2006	Rondinelli et al.
6,709,444	B1	3/2004	Makower	7,153,299	B1	12/2006	Tu et al.
6,712,836	B1	3/2004	Berg et al.	7,171,078	B2	1/2007	Sasaki et al.
6,714,703	B2	3/2004	Lee et al.	7,175,597	B2	2/2007	Vince et al.
6,719,717	B1	4/2004	Johnson et al.	7,177,491	B2	2/2007	Dave et al.
6,725,073	B1	4/2004	Motamedi et al.	7,190,464	B2	3/2007	Alphonse
6,726,677	B1	4/2004	Flaherty et al.	7,215,802	B2	5/2007	Klingensmith et al.
6,730,107	B2	5/2004	Kelley et al.	7,218,811	B2	5/2007	Shigenaga et al.
6,733,474	B2	5/2004	Kusleika	7,236,812	B1	6/2007	Ballerstadt et al.
6,738,144	B1	5/2004	Dogariu	7,245,125	B2	7/2007	Harer et al.
6,740,113	B2	5/2004	Vrba	7,245,789	B2	7/2007	Bates et al.
6,746,464	B1	6/2004	Makower	7,249,357	B2	7/2007	Landman et al.
6,780,157	B2	8/2004	Stephens et al.	7,291,146	B2	11/2007	Steinke et al.
6,795,188	B2	9/2004	Ruck et al.	7,292,715	B2	11/2007	Furnish
6,795,196	B2	9/2004	Funakawa	7,292,885	B2	11/2007	Scott et al.
6,798,522	B2	9/2004	Stolte et al.	7,294,124	B2	11/2007	Eidenschink
6,822,798	B2	11/2004	Wu et al.	7,300,460	B2	11/2007	Levine et al.
6,830,559	B2	12/2004	Schock	7,335,161	B2	2/2008	Von Arx et al.
6,832,024	B2	12/2004	Gerstenberger et al.	7,337,079	B2	2/2008	Park et al.
6,842,639	B1	1/2005	Winston et al.	7,355,716	B2	4/2008	de Boer et al.
6,847,449	B2	1/2005	Bashkansky et al.	7,356,367	B2	4/2008	Liang et al.
6,855,115	B2	2/2005	Fonseca et al.	7,358,921	B2	4/2008	Snyder et al.
6,856,138	B2	2/2005	Bohley	7,359,062	B2	4/2008	Chen et al.
6,856,400	B1	2/2005	Froggatt	7,359,554	B2	4/2008	Klingensmith et al.
6,856,472	B2	2/2005	Herman et al.	7,363,927	B2	4/2008	Ravikumar
6,860,867	B2	3/2005	Seward et al.	7,366,376	B2	4/2008	Shishkov et al.
6,866,670	B2	3/2005	Rabiner et al.	7,382,949	B2	6/2008	Bouma et al.
6,878,113	B2	4/2005	Miwa et al.	7,387,636	B2	6/2008	Cohn et al.
6,886,411	B2	5/2005	Kjellman et al.	7,391,520	B2	6/2008	Zhou et al.
6,891,984	B2	5/2005	Petersen et al.	7,397,935	B2	7/2008	Kimmel et al.
6,895,106	B2	5/2005	Wang et al.	7,399,095	B2	7/2008	Rondinelli
6,898,337	B2	5/2005	Averett et al.	7,408,648	B2	8/2008	Kleen et al.
6,900,897	B2	5/2005	Froggatt	7,414,779	B2	8/2008	Huber et al.
6,912,051	B2	6/2005	Jensen	7,440,087	B2	10/2008	Froggatt et al.
6,916,329	B1	7/2005	Zhao	7,447,388	B2	11/2008	Bates et al.
6,922,498	B2	7/2005	Shah	7,449,821	B2	11/2008	Dausch
6,937,346	B2	8/2005	Nebendahl et al.	7,450,165	B2	11/2008	Ahiska
6,937,696	B1	8/2005	Mostafavi	RE40,608	E	12/2008	Glover et al.
6,943,939	B1	9/2005	DiJaili et al.	7,458,967	B2	12/2008	Appling et al.
6,947,147	B2	9/2005	Motamedi et al.	7,463,362	B2	12/2008	Lasker et al.
6,947,787	B2	9/2005	Webler	7,463,759	B2	12/2008	Klingensmith et al.
				7,491,226	B2	2/2009	Palmaz et al.
				7,515,276	B2	4/2009	Froggatt et al.
				7,527,594	B2	5/2009	Vardi et al.
				7,534,251	B2	5/2009	WasDyke

(56)

References Cited

U.S. PATENT DOCUMENTS

7,535,797 B2	5/2009	Peng et al.	8,057,394 B2	11/2011	Dala-Krishna
7,547,304 B2	6/2009	Johnson	8,059,923 B2	11/2011	Bates et al.
7,564,949 B2	7/2009	Sattler et al.	8,070,800 B2	12/2011	Lock et al.
7,577,471 B2	8/2009	Camus et al.	8,080,800 B2	12/2011	Hocfor et al.
7,583,857 B2	9/2009	Xu et al.	8,088,102 B2	1/2012	Adams et al.
7,603,165 B2	10/2009	Townsend et al.	8,100,838 B2	1/2012	Wright et al.
7,612,773 B2	11/2009	Magnin et al.	8,104,479 B2	1/2012	Glynn et al.
7,633,627 B2	12/2009	Choma et al.	8,108,030 B2	1/2012	Castella et al.
7,645,229 B2	1/2010	Armstrong	8,114,102 B2	2/2012	Galdonik et al.
7,658,715 B2	2/2010	Park et al.	8,116,605 B2	2/2012	Petersen et al.
7,660,452 B2	2/2010	Zwirn et al.	8,125,648 B2	2/2012	Milner et al.
7,660,492 B2	2/2010	Bates et al.	8,126,239 B2	2/2012	Sun et al.
7,666,204 B2	2/2010	Thornton et al.	8,133,199 B2	3/2012	Weber et al.
7,672,790 B2	3/2010	McGraw et al.	8,133,269 B2	3/2012	Flechsengar et al.
7,680,247 B2	3/2010	Atzinger et al.	8,140,708 B2	3/2012	Zaharia et al.
7,684,991 B2	3/2010	Stohr et al.	8,148,877 B2	4/2012	Jiang et al.
7,711,413 B2	5/2010	Feldman et al.	8,167,932 B2	5/2012	Bourang et al.
7,720,322 B2	5/2010	Prisco	8,172,757 B2	5/2012	Jaffe et al.
7,728,986 B2	6/2010	Lasker et al.	8,177,809 B2	5/2012	Mavani et al.
7,734,009 B2	6/2010	Brunner et al.	8,187,191 B2	5/2012	Hancock et al.
7,736,317 B2	6/2010	Stephens et al.	8,187,267 B2	5/2012	Pappone et al.
7,742,795 B2	6/2010	Stone et al.	8,187,830 B2	5/2012	Hu et al.
7,743,189 B2	6/2010	Brown et al.	8,199,218 B2	6/2012	Lee et al.
7,762,954 B2	7/2010	Nix et al.	8,206,429 B2	6/2012	Gregorich et al.
7,766,896 B2	8/2010	Kornkven Volk et al.	8,208,995 B2	6/2012	Tearney et al.
7,773,792 B2	8/2010	Kimmel et al.	8,222,906 B2	7/2012	Wyar et al.
7,775,981 B1	8/2010	Guracar et al.	8,233,681 B2	7/2012	Aylward et al.
7,777,399 B2	8/2010	Eidenschink et al.	8,233,718 B2	7/2012	Klingensmith et al.
7,781,724 B2	8/2010	Childers et al.	8,238,624 B2	8/2012	Doi et al.
7,783,337 B2	8/2010	Feldman et al.	8,239,938 B2	8/2012	Simeral et al.
7,787,127 B2	8/2010	Galle et al.	8,277,386 B2	10/2012	Ahmed et al.
7,792,342 B2	9/2010	Barbu et al.	8,280,470 B2	10/2012	Milner et al.
7,801,343 B2	9/2010	Unal et al.	8,289,284 B2	10/2012	Glynn et al.
7,801,590 B2	9/2010	Feldman et al.	8,289,522 B2	10/2012	Tearney et al.
7,813,609 B2	10/2010	Petersen et al.	8,298,147 B2	10/2012	Huennekens et al.
7,831,081 B2	11/2010	Li	8,298,149 B2	10/2012	Hastings et al.
7,846,101 B2	12/2010	Eberle et al.	8,301,000 B2	10/2012	Sillard et al.
7,853,104 B2	12/2010	Oota et al.	8,309,428 B2	11/2012	Lemmerhirt et al.
7,853,316 B2	12/2010	Milner et al.	8,317,713 B2	11/2012	Davies et al.
7,860,555 B2	12/2010	Saadat	8,323,201 B2	12/2012	Towfiq et al.
7,862,508 B2	1/2011	Davies et al.	8,329,053 B2	12/2012	Martin et al.
7,872,759 B2	1/2011	Tearney et al.	8,336,643 B2	12/2012	Harleman
7,880,868 B2	2/2011	Aoki	8,349,000 B2	1/2013	Schreck
7,881,763 B2	2/2011	Brauker et al.	8,353,945 B2	1/2013	Andreas et al.
7,909,844 B2	3/2011	Alkhatib et al.	8,353,954 B2	1/2013	Cai et al.
7,921,854 B2	4/2011	Hennings et al.	8,357,981 B2	1/2013	Martin et al.
7,927,784 B2	4/2011	Simpson	8,361,097 B2	1/2013	Patel et al.
7,929,148 B2	4/2011	Kemp	8,386,560 B2	2/2013	Ma et al.
7,930,014 B2	4/2011	Huennekens et al.	8,398,591 B2	3/2013	Mas et al.
7,930,104 B2	4/2011	Baker et al.	8,412,312 B2	4/2013	Judell et al.
7,936,462 B2	5/2011	Jiang et al.	8,417,491 B2	4/2013	Trovato et al.
7,942,852 B2	5/2011	Mas et al.	8,449,465 B2	5/2013	Nair et al.
7,947,012 B2	5/2011	Spurchise et al.	8,454,685 B2	6/2013	Hariton et al.
7,951,186 B2	5/2011	Eidenschink et al.	8,454,686 B2	6/2013	Alkhatib
7,952,719 B2	5/2011	Brennan, III	8,475,522 B2	7/2013	Jimenez et al.
7,972,353 B2	7/2011	Hendriksen et al.	8,478,384 B2	7/2013	Schmitt et al.
7,976,492 B2	7/2011	Brauker et al.	8,486,062 B2	7/2013	Belhe et al.
7,977,950 B2	7/2011	Maslen	8,486,063 B2	7/2013	Werneth et al.
7,978,916 B2	7/2011	Klingensmith et al.	8,491,567 B2	7/2013	Magnin et al.
7,981,041 B2	7/2011	McGahan	8,500,798 B2	8/2013	Rowe et al.
7,981,151 B2	7/2011	Rowe	8,550,911 B2	10/2013	Sylla
7,983,737 B2	7/2011	Feldman et al.	8,594,757 B2	11/2013	Boppart et al.
7,993,333 B2	8/2011	Oral et al.	8,597,349 B2	12/2013	Alkhatib
7,995,210 B2	8/2011	Tearney et al.	8,600,477 B2	12/2013	Beyar et al.
7,996,060 B2	8/2011	Trofimov et al.	8,600,917 B1	12/2013	Schimert et al.
7,999,938 B2	8/2011	Wang	8,601,056 B2	12/2013	Lauwers et al.
8,021,377 B2	9/2011	Eskuri	8,620,055 B2	12/2013	Barratt et al.
8,021,420 B2	9/2011	Dolan	8,644,910 B2	2/2014	Rouso et al.
8,036,732 B2	10/2011	Milner	2001/0007940 A1	7/2001	Tu et al.
8,040,586 B2	10/2011	Smith et al.	2001/0029337 A1	10/2001	Pantages et al.
8,047,996 B2	11/2011	Goodnow et al.	2001/0037073 A1	11/2001	White et al.
8,049,900 B2	11/2011	Kemp et al.	2001/0046345 A1	11/2001	Snyder et al.
8,050,478 B2	11/2011	Li et al.	2001/0049548 A1	12/2001	Vardi et al.
8,050,523 B2	11/2011	Younge et al.	2002/0034276 A1	3/2002	Hu et al.
8,052,605 B2	11/2011	Muller et al.	2002/0041723 A1	4/2002	Ronnekleiv et al.
			2002/0069676 A1	6/2002	Kopp et al.
			2002/0089335 A1	7/2002	Williams
			2002/0099289 A1	7/2002	Crowley
			2002/0163646 A1	11/2002	Anderson

(56)

References Cited

U.S. PATENT DOCUMENTS

2002/0186818 A1	12/2002	Arnaud et al.	2005/0251567 A1	11/2005	Ballew et al.
2002/0196446 A1	12/2002	Roth et al.	2005/0254059 A1	11/2005	Alphonse
2002/0197456 A1	12/2002	Pope	2005/0264823 A1	12/2005	Zhu et al.
2003/0004412 A1	1/2003	Izatt et al.	2006/0013523 A1	1/2006	Childlers et al.
2003/0016604 A1	1/2003	Hanes	2006/0015126 A1	1/2006	Sher
2003/0018273 A1	1/2003	Corl et al.	2006/0029634 A1	2/2006	Berg et al.
2003/0023153 A1	1/2003	Izatt et al.	2006/0036167 A1	2/2006	Shina
2003/0032886 A1	2/2003	Dgany et al.	2006/0038115 A1	2/2006	Maas
2003/0050871 A1	3/2003	Broughton	2006/0039004 A1	2/2006	de Boer et al.
2003/0065371 A1	4/2003	Satake	2006/0041180 A1	2/2006	Viswanathan et al.
2003/0069723 A1	4/2003	Hegde	2006/0045536 A1	3/2006	Arahira
2003/0077043 A1	4/2003	Hamm et al.	2006/0055936 A1	3/2006	Yun et al.
2003/0085635 A1	5/2003	Davidson	2006/0058622 A1	3/2006	Tearney et al.
2003/0090753 A1	5/2003	Takeyama et al.	2006/0058647 A1*	3/2006	Strommer A61B 5/06 600/434
2003/0092995 A1	5/2003	Thompson	2006/0064009 A1	3/2006	Webler et al.
2003/0093059 A1	5/2003	Griffin et al.	2006/0067620 A1	3/2006	Shishkov et al.
2003/0103212 A1	6/2003	Westphal et al.	2006/0072808 A1	4/2006	Grimm et al.
2003/0152259 A1	8/2003	Belykh et al.	2006/0074442 A1	4/2006	Noriega et al.
2003/0181802 A1	9/2003	Ogawa	2006/0098927 A1	5/2006	Schmidt et al.
2003/0187369 A1	10/2003	Lewis et al.	2006/0100694 A1	5/2006	Globerman
2003/0194165 A1	10/2003	Silberberg et al.	2006/0106375 A1	5/2006	Werneth et al.
2003/0195419 A1	10/2003	Harada	2006/0132790 A1	6/2006	Gutin
2003/0208116 A1*	11/2003	Liang et al. 600/407	2006/0135870 A1	6/2006	Webler
2003/0212491 A1	11/2003	Mitchell et al.	2006/0142703 A1	6/2006	Carter et al.
2003/0219202 A1	11/2003	Loeb et al.	2006/0142733 A1	6/2006	Forsberg
2003/0220749 A1	11/2003	Chen et al.	2006/0173299 A1	8/2006	Romley et al.
2003/0228039 A1	12/2003	Green	2006/0179255 A1	8/2006	Yamazaki
2004/0015065 A1	1/2004	Panescu et al.	2006/0184048 A1	8/2006	Saadat
2004/0023317 A1	2/2004	Motamedi et al.	2006/0187537 A1	8/2006	Huber et al.
2004/0028333 A1	2/2004	Lomas	2006/0195269 A1	8/2006	Yeatman et al.
2004/0037742 A1	2/2004	Jen et al.	2006/0204119 A1	9/2006	Feng et al.
2004/0042066 A1	3/2004	Kinoshita et al.	2006/0229591 A1	10/2006	Lee
2004/0054287 A1	3/2004	Stephens	2006/0239312 A1	10/2006	Kewitsch et al.
2004/0067000 A1	4/2004	Bates et al.	2006/0241342 A1	10/2006	Macaulay et al.
2004/0068161 A1	4/2004	Couvillon	2006/0241465 A1	10/2006	Huennekens et al.
2004/0082844 A1	4/2004	Vardi et al.	2006/0241503 A1	10/2006	Schmitt et al.
2004/0092830 A1	5/2004	Scott et al.	2006/0244973 A1	11/2006	Yun et al.
2004/0106853 A1	6/2004	Moriyama	2006/0258895 A1	11/2006	Maschke
2004/0111552 A1	6/2004	Arimilli et al.	2006/0264743 A1	11/2006	Kleen et al.
2004/0126048 A1	7/2004	Dave et al.	2006/0267756 A1	11/2006	Kates
2004/0143160 A1	7/2004	Couvillon	2006/0270976 A1	11/2006	Savage et al.
2004/0146546 A1	7/2004	Gravett et al.	2006/0276709 A1	12/2006	Khamene et al.
2004/0186369 A1	9/2004	Lam	2006/0279742 A1	12/2006	Tearney et al.
2004/0186558 A1	9/2004	Pavcnik et al.	2006/0279743 A1	12/2006	Boesser et al.
2004/0195512 A1	10/2004	Crosetto	2006/0285638 A1	12/2006	Boese et al.
2004/0220606 A1	11/2004	Goshgarian	2006/0287595 A1	12/2006	Maschke
2004/0225220 A1	11/2004	Rich	2006/0293597 A1	12/2006	Johnson et al.
2004/0239938 A1	12/2004	Izatt	2007/0015969 A1	1/2007	Feldman et al.
2004/0242990 A1	12/2004	Brister et al.	2007/0016029 A1	1/2007	Donaldson et al.
2004/0248439 A1	12/2004	Gernhardt et al.	2007/0016034 A1	1/2007	Donaldson
2004/0249270 A1	12/2004	Kondo	2007/0016062 A1	1/2007	Park et al.
2004/0260236 A1	12/2004	Manning et al.	2007/0027390 A1	2/2007	Maschke et al.
2005/0013778 A1	1/2005	Green et al.	2007/0036417 A1	2/2007	Argiro et al.
2005/0031176 A1	2/2005	Hertel et al.	2007/0038061 A1	2/2007	Huennekens et al.
2005/0036150 A1	2/2005	Izatt et al.	2007/0038121 A1	2/2007	Feldman et al.
2005/0065432 A1*	3/2005	Kimura A61B 5/0263 600/420	2007/0038125 A1	2/2007	Kleen et al.
2005/0078317 A1	4/2005	Law et al.	2007/0043292 A1	2/2007	Camus et al.
2005/0101859 A1	5/2005	Maschke	2007/0043597 A1	2/2007	Donaldson
2005/0140582 A1	6/2005	Lee et al.	2007/0049847 A1	3/2007	Osborne
2005/0140682 A1	6/2005	Sumanaweera et al.	2007/0060973 A1	3/2007	Ludvig et al.
2005/0140981 A1	6/2005	Waelti	2007/0065077 A1	3/2007	Childers et al.
2005/0140984 A1	6/2005	Hitzenberger	2007/0066888 A1	3/2007	Maschke
2005/0147303 A1	7/2005	Zhou et al.	2007/0066890 A1	3/2007	Maschke
2005/0165439 A1	7/2005	Weber et al.	2007/0066983 A1	3/2007	Maschke
2005/0171433 A1	8/2005	Boppart et al.	2007/0084995 A1	4/2007	Newton et al.
2005/0171438 A1	8/2005	Chen et al.	2007/0100226 A1	5/2007	Yankelevitz et al.
2005/0182297 A1	8/2005	Gravenstein et al.	2007/0135887 A1	6/2007	Maschke
2005/0196028 A1	9/2005	Kleen et al.	2007/0142707 A1	6/2007	Wiklof et al.
2005/0197585 A1	9/2005	Brockway et al.	2007/0156019 A1	7/2007	Larkin et al.
2005/0213103 A1	9/2005	Everett et al.	2007/0161893 A1	7/2007	Milner et al.
2005/0215942 A1	9/2005	Abrahamson et al.	2007/0161896 A1	7/2007	Adachi et al.
2005/0234445 A1	10/2005	Conquergood et al.	2007/0161963 A1	7/2007	Smalling
2005/0243322 A1	11/2005	Lasker et al.	2007/0162860 A1	7/2007	Muralidharan et al.
2005/0249391 A1	11/2005	Kimmel et al.	2007/0165141 A1	7/2007	Srinivas et al.
			2007/0167710 A1	7/2007	Unal et al.
			2007/0167804 A1	7/2007	Park et al.
			2007/0191682 A1	8/2007	Rolland et al.
			2007/0201736 A1	8/2007	Klingensmith et al.

(56)

References Cited

U.S. PATENT DOCUMENTS

2007/0206193 A1	9/2007	Pesach	2009/0069843 A1	3/2009	Agnew
2007/0208276 A1	9/2007	Kornkven Volk et al.	2009/0079993 A1	3/2009	Yatagai et al.
2007/0225220 A1	9/2007	Ming et al.	2009/0088650 A1	4/2009	Corl
2007/0225590 A1	9/2007	Ramos	2009/0093980 A1	4/2009	Kemp et al.
2007/0229801 A1	10/2007	Tearney et al.	2009/0122320 A1	5/2009	Petersen et al.
2007/0232872 A1	10/2007	Prough et al.	2009/0138544 A1	5/2009	Wegenkittl et al.
2007/0232874 A1	10/2007	Ince	2009/0149739 A9	6/2009	Maschke
2007/0232890 A1	10/2007	Hirota	2009/0156941 A1	6/2009	Moore
2007/0232891 A1	10/2007	Hirota	2009/0174886 A1	7/2009	Inoue
2007/0232892 A1	10/2007	Hirota	2009/0174931 A1	7/2009	Huber et al.
2007/0232893 A1	10/2007	Tanioka	2009/0177090 A1	7/2009	Grunwald et al.
2007/0232933 A1	10/2007	Gille et al.	2009/0177183 A1	7/2009	Pinkernell et al.
2007/0238957 A1	10/2007	Yared	2009/0195514 A1	8/2009	Glynn et al.
2007/0247033 A1	10/2007	Eidenschink et al.	2009/0196470 A1	8/2009	Carl et al.
2007/0250000 A1	10/2007	Magnin et al.	2009/0198125 A1	8/2009	Nakabayashi et al.
2007/0250036 A1	10/2007	Volk et al.	2009/0203991 A1	8/2009	Papaioannou et al.
2007/0258094 A1	11/2007	Izatt et al.	2009/0264768 A1	10/2009	Courtney et al.
2007/0258632 A1*	11/2007	Friedman A61B 8/08 382/128	2009/0269014 A1	10/2009	Winberg et al.
2007/0260138 A1	11/2007	Feldman et al.	2009/0270695 A1	10/2009	McEowen
2007/0278389 A1	12/2007	Ajgaonkar et al.	2009/0284322 A1	11/2009	Harrison et al.
2007/0287914 A1	12/2007	Cohen	2009/0284332 A1	11/2009	Moore et al.
2008/0002183 A1	1/2008	Yatagai et al.	2009/0284749 A1	11/2009	Johnson et al.
2008/0013093 A1	1/2008	Izatt et al.	2009/0290167 A1	11/2009	Flanders et al.
2008/0021275 A1	1/2008	Tearney et al.	2009/0292048 A1	11/2009	Li et al.
2008/0027481 A1	1/2008	Gilson et al.	2009/0299195 A1	12/2009	Muller et al.
2008/0043024 A1	2/2008	Schiwietz et al.	2009/0299284 A1	12/2009	Holman et al.
2008/0045842 A1	2/2008	Furnish	2009/0306520 A1	12/2009	Schmitt
2008/0051660 A1	2/2008	Kakadaris et al.	2009/0318951 A1	12/2009	Kashkarov et al.
2008/0055308 A1*	3/2008	Dekel G06T 15/08 345/421	2009/0326634 A1	12/2009	Vardi
2008/0063304 A1	3/2008	Russak et al.	2010/0007669 A1	1/2010	Bethune et al.
2008/0085041 A1	4/2008	Breeuwer	2010/0030042 A1	2/2010	Denninghoff et al.
2008/0095465 A1	4/2008	Mullick et al.	2010/0061611 A1	3/2010	Xu et al.
2008/0095714 A1	4/2008	Castella et al.	2010/0063400 A1	3/2010	Hall et al.
2008/0097194 A1	4/2008	Milner	2010/0081931 A1*	4/2010	Destrempes G06T 7/12 600/437
2008/0101667 A1*	5/2008	Begelman et al. 382/128	2010/0087732 A1	4/2010	Eberle et al.
2008/0108867 A1	5/2008	Zhou	2010/0094125 A1	4/2010	Younge et al.
2008/0114254 A1	5/2008	Matcovitch et al.	2010/0094127 A1*	4/2010	Xu 600/425
2008/0119739 A1	5/2008	Vardi et al.	2010/0094135 A1	4/2010	Fang-Yen et al.
2008/0124495 A1	5/2008	Horn et al.	2010/0094143 A1	4/2010	Mahapatra et al.
2008/0125772 A1	5/2008	Stone et al.	2010/0113919 A1	5/2010	Maschke
2008/0139897 A1	6/2008	Ainsworth et al.	2010/0125238 A1	5/2010	Lye et al.
2008/0143707 A1	6/2008	Mitchell	2010/0125268 A1	5/2010	Gustus et al.
2008/0146941 A1	6/2008	Dala-Krishna	2010/0125648 A1	5/2010	Zaharia et al.
2008/0147111 A1	6/2008	Johnson et al.	2010/0128348 A1	5/2010	Taverner
2008/0154128 A1	6/2008	Milner	2010/0152717 A1	6/2010	Keeler
2008/0161696 A1	7/2008	Schmitt et al.	2010/0160788 A1	6/2010	Davies et al.
2008/0171944 A1	7/2008	Brenneman et al.	2010/0161023 A1	6/2010	Cohen et al.
2008/0175465 A1	7/2008	Jiang et al.	2010/0168714 A1	7/2010	Burke et al.
2008/0177183 A1	7/2008	Courtney et al.	2010/0179421 A1	7/2010	Tupin
2008/0180683 A1	7/2008	Kemp	2010/0179426 A1	7/2010	Davies et al.
2008/0181477 A1	7/2008	Izatt et al.	2010/0220334 A1	9/2010	Condit et al.
2008/0187201 A1	8/2008	Liang et al.	2010/0226607 A1	9/2010	Zhang et al.
2008/0228086 A1	9/2008	Ilegbusi et al.	2010/0234736 A1	9/2010	Corl
2008/0247622 A1	10/2008	Aylward et al.	2010/0249601 A1	9/2010	Courtney
2008/0247716 A1	10/2008	Thomas et al.	2010/0256616 A1	10/2010	Katoh et al.
2008/0262470 A1	10/2008	Lee et al.	2010/0272432 A1	10/2010	Johnson
2008/0262489 A1	10/2008	Steinke	2010/0284590 A1	11/2010	Peng et al.
2008/0269599 A1	10/2008	Csavoy et al.	2010/0290693 A1	11/2010	Cohen et al.
2008/0281205 A1	11/2008	Naghavi et al.	2010/0331950 A1	12/2010	Strommer
2008/0281248 A1	11/2008	Angheloiu et al.	2011/0010925 A1	1/2011	Nix et al.
2008/0285043 A1	11/2008	Fercher et al.	2011/0021926 A1	1/2011	Spencer et al.
2008/0287795 A1	11/2008	Klingensmith et al.	2011/0025853 A1	2/2011	Richardson
2008/0291463 A1	11/2008	Milner et al.	2011/0026797 A1	2/2011	Declerck et al.
2008/0292173 A1	11/2008	Hsieh et al.	2011/0032533 A1	2/2011	Izatt et al.
2008/0294034 A1	11/2008	Krueger et al.	2011/0034801 A1	2/2011	Baumgart
2008/0298655 A1	12/2008	Edwards	2011/0044546 A1	2/2011	Pan et al.
2008/0306766 A1	12/2008	Ozeki et al.	2011/0066073 A1	3/2011	Kuiper et al.
2009/0009801 A1	1/2009	Tabuki	2011/0071401 A1	3/2011	Hastings et al.
2009/0018393 A1	1/2009	Dick et al.	2011/0071404 A1	3/2011	Schmitt
2009/0034813 A1	2/2009	Dikmen et al.	2011/0072405 A1	3/2011	Chen et al.
2009/0043191 A1	2/2009	Castella et al.	2011/0077528 A1	3/2011	Kemp et al.
2009/0046295 A1	2/2009	Kemp et al.	2011/0080591 A1	4/2011	Johnson et al.
2009/0052614 A1	2/2009	Hempel et al.	2011/0087104 A1	4/2011	Moore et al.
			2011/0137140 A1	6/2011	Tearney et al.
			2011/0144502 A1	6/2011	Zhou et al.
			2011/0152771 A1	6/2011	Milner et al.
			2011/0157597 A1	6/2011	Lu et al.
			2011/0160586 A1	6/2011	Li et al.

(56)

References Cited

U.S. PATENT DOCUMENTS

2011/0178413 A1 7/2011 Schmitt et al.
 2011/0190586 A1 8/2011 Kemp
 2011/0216378 A1 9/2011 Poon et al.
 2011/0220985 A1 9/2011 Son et al.
 2011/0238061 A1 9/2011 van der Weide et al.
 2011/0238083 A1 9/2011 Moll et al.
 2011/0245669 A1 10/2011 Zhang
 2011/0249094 A1 10/2011 Wang et al.
 2011/0257545 A1 10/2011 Suri
 2011/0263960 A1* 10/2011 Mitchell 600/373
 2011/0264125 A1 10/2011 Wilson et al.
 2011/0274329 A1 11/2011 Mathew et al.
 2011/0282334 A1 11/2011 Groenhoff
 2011/0301684 A1 12/2011 Fischell et al.
 2011/0306995 A1 12/2011 Moberg
 2011/0319752 A1 12/2011 Steinberg et al.
 2012/0004529 A1 1/2012 Tolkowsky et al.
 2012/0004668 A1 1/2012 Wallace et al.
 2012/0013914 A1 1/2012 Kemp et al.
 2012/0016344 A1 1/2012 Kusakabe
 2012/0016395 A1 1/2012 Olson
 2012/0022360 A1 1/2012 Kemp
 2012/0026503 A1 2/2012 Lewandowski et al.
 2012/0029007 A1 2/2012 Graham et al.
 2012/0059253 A1 3/2012 Wang et al.
 2012/0059368 A1 3/2012 Takaoko et al.
 2012/0062843 A1 3/2012 Ferguson et al.
 2012/0065481 A1 3/2012 Hunter et al.
 2012/0071823 A1 3/2012 Chen
 2012/0071838 A1 3/2012 Fojtik
 2012/0075638 A1 3/2012 Rollins et al.
 2012/0083696 A1 4/2012 Kitamura
 2012/0095340 A1 4/2012 Smith
 2012/0095372 A1 4/2012 Sverdluk et al.
 2012/0108943 A1 5/2012 Bates et al.
 2012/0113108 A1 5/2012 Dala-Krishna
 2012/0116353 A1 5/2012 Arnold et al.
 2012/0130243 A1 5/2012 Balocco et al.
 2012/0130247 A1 5/2012 Waters et al.
 2012/0136259 A1 5/2012 Milner et al.
 2012/0136427 A1 5/2012 Palmaz et al.
 2012/0137075 A1 5/2012 Vorbach
 2012/0155734 A1 6/2012 Barratt et al.
 2012/0158101 A1 6/2012 Stone et al.
 2012/0162660 A1 6/2012 Kemp
 2012/0165661 A1 6/2012 Kemp et al.
 2012/0170848 A1 7/2012 Kemp et al.
 2012/0172698 A1 7/2012 Teo et al.
 2012/0176607 A1 7/2012 Ott
 2012/0184853 A1 7/2012 Waters
 2012/0184859 A1 7/2012 Shah et al.
 2012/0184977 A1 7/2012 Wolf
 2012/0215094 A1 8/2012 Rahimian et al.
 2012/0220836 A1 8/2012 Alpert et al.
 2012/0220851 A1 8/2012 Razansky et al.
 2012/0220865 A1 8/2012 Brown et al.
 2012/0220874 A1 8/2012 Hancock et al.
 2012/0220883 A1 8/2012 Manstrom et al.
 2012/0224751 A1 9/2012 Kemp et al.
 2012/0226153 A1 9/2012 Brown et al.
 2012/0230565 A1 9/2012 Steinberg et al.
 2012/0232400 A1 9/2012 Dickinson et al.
 2012/0238869 A1 9/2012 Schmitt et al.
 2012/0238956 A1 9/2012 Yamada et al.
 2012/0244043 A1 9/2012 Leblanc et al.
 2012/0250028 A1 10/2012 Schmitt et al.
 2012/0253186 A1 10/2012 Simpson et al.
 2012/0253192 A1 10/2012 Cressman
 2012/0253276 A1 10/2012 Govari et al.
 2012/0257210 A1 10/2012 Whitney et al.
 2012/0262720 A1 10/2012 Brown et al.
 2012/0265077 A1 10/2012 Gille et al.
 2012/0265268 A1 10/2012 Blum et al.
 2012/0265296 A1 10/2012 McNamara et al.
 2012/0271170 A1 10/2012 Emelianov et al.

2012/0271175 A1 10/2012 Moore et al.
 2012/0271339 A1 10/2012 O'Beirne et al.
 2012/0274338 A1 11/2012 Baks et al.
 2012/0276390 A1 11/2012 Ji et al.
 2012/0277722 A1 11/2012 Gerber et al.
 2012/0279764 A1 11/2012 Jiang et al.
 2012/0283758 A1 11/2012 Miller et al.
 2012/0289987 A1 11/2012 Wilson et al.
 2012/0299439 A1 11/2012 Huang
 2012/0310081 A1 12/2012 Adler et al.
 2012/0310332 A1 12/2012 Murray et al.
 2012/0319535 A1 12/2012 Dausch
 2012/0323075 A1 12/2012 Younge et al.
 2012/0323127 A1 12/2012 Boyden et al.
 2012/0330141 A1 12/2012 Brown et al.
 2013/0015975 A1 1/2013 Huennekens et al.
 2013/0023762 A1 1/2013 Huennekens et al.
 2013/0023763 A1 1/2013 Huennekens et al.
 2013/0026655 A1 1/2013 Lee et al.
 2013/0030295 A1 1/2013 Huennekens et al.
 2013/0030303 A1 1/2013 Ahmed et al.
 2013/0030410 A1 1/2013 Drasler et al.
 2013/0053949 A1 2/2013 Pintor et al.
 2013/0109958 A1 5/2013 Baumgart et al.
 2013/0109959 A1 5/2013 Baumgart et al.
 2013/0137980 A1 5/2013 Waters et al.
 2013/0150716 A1 6/2013 Stigall et al.
 2013/0158594 A1 6/2013 Carrison et al.
 2013/0218201 A1 8/2013 Obermiller et al.
 2013/0218267 A1 8/2013 Braidon et al.
 2013/0223789 A1 8/2013 Lee et al.
 2013/0223798 A1 8/2013 Jenner et al.
 2013/0296704 A1 11/2013 Magnin et al.
 2013/0303907 A1 11/2013 Corl
 2013/0303920 A1 11/2013 Corl
 2013/0310698 A1 11/2013 Judell et al.
 2013/0331820 A1 12/2013 Itou et al.
 2013/0338766 A1 12/2013 Hastings et al.
 2013/0339958 A1 12/2013 Droste et al.
 2014/0039294 A1 2/2014 Jiang
 2014/0180067 A1 6/2014 Stigall et al.
 2014/0180128 A1 6/2014 Corl
 2014/0200438 A1 7/2014 Millett et al.

FOREIGN PATENT DOCUMENTS

EP 2438877 A2 4/2012
 GB 2280261 A 1/1995
 JP 2000-262461 A 9/2000
 JP 2000-292260 A 10/2000
 JP 2001-125009 A 5/2001
 JP 2001-272331 A 10/2001
 JP 2002-374034 A 12/2002
 JP 2003-143783 A 5/2003
 JP 2003-172690 A 6/2003
 JP 2003-256876 A 9/2003
 JP 2003-287534 A 10/2003
 JP 2005-274380 A 10/2005
 JP 2006167287 A 6/2006
 JP 2006-184284 A 7/2006
 JP 2006-266797 A 10/2006
 JP 2006-313158 A 11/2006
 JP 2007-024677 A 1/2007
 JP 2009-233001 A 10/2009
 JP 2009-536425 A 10/2009
 JP 2011-56786 A 3/2011
 WO 91/01156 A1 2/1991
 WO 92/16865 A1 10/1992
 WO 93/06213 A1 4/1993
 WO 93/08829 A1 5/1993
 WO 98/38907 A1 9/1998
 WO 98/57583 A1 12/1998
 WO 00/11511 A1 3/2000
 WO 00/044296 A1 8/2000
 WO 01/11409 A2 2/2001
 WO 03/062802 A2 7/2003
 WO 03/073950 A1 9/2003
 WO 2004/010856 A1 2/2004
 WO 2004/023992 A1 3/2004

(56)

References Cited

FOREIGN PATENT DOCUMENTS

WO	2004/096049	A2	11/2004
WO	2005/047813	A1	5/2005
WO	2005/106695	A2	11/2005
WO	2006/029634	A2	3/2006
WO	2006/037132	A1	4/2006
WO	2006/039091	A2	4/2006
WO	2006/061829	A1	6/2006
WO	2006/068875	A2	6/2006
WO	2006/111704	A1	10/2006
WO	2006/119416	A2	11/2006
WO	2006/121851	A2	11/2006
WO	2006/130802	A2	12/2006
WO	2007/002685	A2	1/2007
WO	2007/025230	A2	3/2007
WO	2007/045690	A1	4/2007
WO	2007/058895	A2	5/2007
WO	2007/067323	A2	6/2007
WO	2007/084995	A2	7/2007
WO	2008/058084	A2	5/2008
WO	2008/069991	A1	6/2008
WO	2008/107905	A2	9/2008
WO	2009/009799	A1	1/2009
WO	2009/009801	A1	1/2009
WO	2009/046431	A1	4/2009
WO	2009/121067	A1	10/2009
WO	2009/137704	A1	11/2009
WO	2011/068886	A2	1/2011
WO	2011/038048	A1	3/2011
WO	2011/081688	A1	7/2011
WO	2012/003369	A2	1/2012
WO	2012/061935	A1	5/2012
WO	2012/071388	A2	5/2012
WO	2012/087818	A1	6/2012
WO	2012/098194	A1	7/2012
WO	2012/109676	A1	8/2012
WO	2012/130289	A1	10/2012
WO	2012/154767	A2	11/2012
WO	2012/155040	A1	11/2012
WO	2013/033414	A1	3/2013
WO	2013/033415	A2	3/2013
WO	2013/033418	A1	3/2013
WO	2013/033489	A1	3/2013
WO	2013/033490	A1	3/2013
WO	2013/033592	A1	3/2013
WO	2013/126390	A1	8/2013
WO	2014/109879	A1	7/2014

OTHER PUBLICATIONS

Adler et al., 2007, Phase-Sensitive Optical Coherence Tomography at up to 370,000 Lines Per Second Using Buffered Fourier Domain Mode-Locked Lasers, *Optics Letters*, 32(6):626-628.

Agresti, 1996, Models for Matched Pairs, Chapter 8, An Introduction to Categorical Data Analysis, Wiley-Interscience A John Wiley & Sons, Inc., Publication, Hoboken, New Jersey.

Akashah et al., 2004, Development of piezoelectric micromachined ultrasonic transducers, *Sensors and Actuators A Physical*, 111:275-287.

Amini et al., 1990, Using dynamic programming for solving variational problems in vision, *IEEE Transactions on Pattern Analysis and Machine Intelligence*, 12(9):855-867.

Bail et al., 1996, Optical coherence tomography with the "Spectral Radar"—Fast optical analysis in volume scatterers by short coherence interferometry, *Optics Letters* 21(14):1087-1089.

Bain, 2011, Privacy protection and face recognition, Chapter 3, *Handbook of Face Recognition*, Stan et al., Springer-Verlag.

Barnea et al., 1972, A class of algorithms for fast digital image registration, *IEEE Trans. Computers*, 21(2):179-186.

Blanchet et al., 1993, Laser Ablation and the Production of Polymer Films, *Science*, 262(5134):719-721.

Bonnema, 2008, Imaging Tissue Engineered Blood Vessel Mimics with Optical Tomography, College of Optical Sciences dissertation, University of Arizona (252 pages).

Bouma et al., 1999, Power-efficient nonreciprocal interferometer and linear-scanning fiber-optic catheter for optical coherence tomography, *Optics Letters*, 24(8):531-533.

Breiman, 2001, Random forests, *Machine Learning* 45:5-32.

Brown, 1992, A survey of image registration techniques, *ACM Computing Surveys* 24(4):325-376.

Bruining et al., 2009, Intravascular Ultrasound Registration/Integration with Coronary Angiography, *Cardiology Clinics*, 27(3):531-540.

Brummer, 1997, An euclidean distance measure between covariance matrices of speechceptra for text-independent speaker recognition, in *Proc. South African Symp. Communications and Signal Processing*:167-172.

Burr et al., 2005, Searching for the Center of an Ellipse in Proceedings of the 17th Canadian Conference on Computational Geometry:260-263.

Canny, 1986, A computational approach to edge detection, *IEEE Trans. Pattern Anal. Mach. Intell.* 8:679-698.

Cavalli et al., 2010, Nanosponge formulations as oxygen delivery systems, *International Journal of Pharmaceutics* 402:254-257.

Choma et al., 2003, Sensitivity Advantage of Swept Source and Fourier Domain Optical Coherence Tomography, *Optics Express* 11(18):2183-2189.

Clarke et al., 1995, Hypoxia and myocardial ischaemia during peripheral angioplasty, *Clinical Radiology*, 50(5):301-303.

Collins, 1993, Coronary flow reserve, *British Heart Journal* 69:279-281.

Communication Mechanisms for Distributed Real-Time Applications, NI Developer Zone, <http://zone.ni.com/devzone/cda/tut/p/id/3105>, accessed Jul. 23, 2007.

Cook, 2007, Use and misuse of receiver operating characteristic curve in risk prediction, *Circulation* 115(7):928-35.

D'Agostino et al., 2001, Validation of the Framingham coronary heart disease prediction score: results of a multiple ethnic group investigation, *JAMA* 286:180-187.

David et al., 1974, Protein iodination with solid-state lactoperoxidase, *Biochemistry* 13:1014-1021.

Davies et al., 1985, Plaque fissuring—the cause of acute myocardial infarction, sudden ischaemic death, and crescendo angina, *British Heart Journal* 53:363-373.

Davies et al., 1993, Risk of thrombosis in human atherosclerotic plaques: role of extracellular lipid, macrophage, and smooth muscle cell content, *British Heart Journal* 69:377-381.

Deterministic Data Streaming in Distributed Data Acquisition Systems, NI Developer Zone, "What is Developer Zone?", <http://zone.ni.com/devzone/cda/tut/p/id/3105>, accessed Jul. 23, 2007.

Eigenwillig, 2008, K-Space Linear Fourier Domain Mode Locked Laser and Applications for Optical Coherence Tomography, *Optics Express* 16(12):8916-8937.

Elghanian et al., 1997, Selective colorimetric detection of polynucleotides based on the distance-dependent optical properties of gold nanoparticles, *Science*, 277(5329):1078-1080.

Ergun et al., 2003, Capacitive Micromachined Ultrasonic Transducers: Theory and Technology, *Journal of Aerospace Engineering*, 16(2):76-84.

Evans et al., 2006, Optical coherence tomography to identify intramucosa carcinoma and high-grade dysplasia in Barrett's esophagus, *Clin Gast Hepat* 4(1):38-43.

Fatemi et al., 1999, Vibro-acoustography: an imaging modality based on ultrasound-stimulated acoustic emission, *PNAS U.S.A.*, 96(12):6603-6608.

Felzenszwalb et al., 2005, Pictorial Structures for Object Recognition, *International Journal of Computer Vision*, 61(1):55-79.

Ferring et al., 2008, Vasculature ultrasound for the pre-operative evaluation prior to arteriovenous fistula formation for haemodialysis: review of the evidence, *Nephrol. Dial. Transplant.* 23(6):1809-1815.

Fischler et al., 1973, The representation and matching of pictorial structures, *IEEE Transactions on Computer* 22:67-92.

Fleming et al., 2010, Real-time monitoring of cardiac radio-frequency ablation lesion formation using an optical coherence tomography forward-imaging catheter, *Journal of Biomedical Optics* 15 (3):030516-1 (3 pages).

(56)

References Cited

OTHER PUBLICATIONS

- Fookes et al., 2002, Rigid and non-rigid image registration and its association with mutual information: A review, Technical Report ISBN:1 86435 569 7, RCCVA, QUT.
- Forstner & Moonen, 1999, A metric for covariance matrices, In Technical Report of the Dpt of Geodesy and Geoinformatics, Stuttgart University, 113-128.
- Goel et al., 2006, Minimally Invasive Limited Ligation Endoluminal-assisted Revision (MILLER) for treatment of dialysis access-associated steal syndrome, *Kidney Int* 70(4):765-70.
- Gotzinger et al., 2005, High speed spectral domain polarization sensitive optical coherence tomography of the human retina, *Optics Express* 13(25):10217-10229.
- Gould et al., 1974, Physiologic basis for assessing critical coronary stenosis, *American Journal of Cardiology*, 33:87-94.
- Griffiths et al., 1993, Human anti-self antibodies with high specificity from phage display libraries, *The EMBO Journal*, 12:725-734.
- Griffiths et al., 1994, Isolation of high affinity human antibodies directly from large synthetic repertoires, *The EMBO Journal*, 13(14):3245-3260.
- Grund et al., 2010, Analysis of biomarker data: logs, odds, ratios and ROC curves, *Curr Opin HIV AIDS* 5(6):473-479.
- Harrison et al., 2011, Guidewire Stiffness: What's in a name?, *J Endovasc Ther*, 18(6):797-801.
- Huber et al., 2005, Amplified, Frequency Swept Lasers for Frequency Domain Reflectometry and OCT Imaging: Design and Scaling Principles, *Optics Express* 13(9):3513-3528.
- Huber et al., 2006, Fourier Domain Mode Locking (FDML): A New Laser Operating Regime and Applications for Optical Coherence Tomography, *Optics Express* 14(8):3225-3237.
- International Search Report and Written Opinion dated Mar. 11, 2014, for International Patent Application No. PCT/US13/75675, filed Dec. 17, 2013 (7 pages).
- International Search Report and Written Opinion dated Mar. 19, 2014, for International Patent Application No. PCT/US13/075353, filed Dec. 16, 2013 (8 pages).
- International Search Report and Written Opinion dated Nov. 2, 2012, for International Patent Application No. PCT/US12/53168, filed Aug. 30, 2013 (8 pages).
- International Search Report and Written Opinion dated Apr. 14, 2014, for International Patent Application No. PCT/US2013/076148, filed Dec. 18, 2013 (8 pages).
- International Search Report and Written Opinion dated Apr. 21, 2014, for International Patent Application No. PCT/US2013/076015, filed Dec. 18, 2013 (7 pages).
- International Search Report and Written Opinion dated Apr. 23, 2014, for International Patent Application No. PCT/US2013/075328, filed Dec. 16, 2013 (8 pages).
- International Search Report and Written Opinion dated Apr. 29, 2014, for International Patent Application No. PCT/US13/76093, filed Dec. 18, 2013 (6 pages).
- International Search Report and Written Opinion dated Apr. 9, 2014, for International Patent Application No. PCT/US13/75089, filed Dec. 13, 2013 (7 pages).
- International Search Report and Written Opinion dated Feb. 21, 2014, for International Patent Application No. PCT/US13/76053, filed Dec. 18, 2013 (9 pages).
- International Search Report and Written Opinion dated Feb. 21, 2014, for International Patent Application No. PCT/US2013/076965, filed Dec. 20, 2013 (6 pages).
- International Search Report and Written Opinion dated Feb. 27, 2014, for International Patent Application No. PCT/US13/75416, filed Dec. 16, 2013 (7 pages).
- International Search Report and Written Opinion dated Feb. 28, 2014, for International Patent Application No. PCT/US13/75653, filed Dec. 17, 2013 (7 pages).
- International Search Report and Written Opinion dated Feb. 28, 2014, for International Patent Application No. PCT/US13/75990, filed Dec. 18, 2013 (7 pages).
- International Search Report and Written Opinion dated Jan. 16, 2009, for International Patent Application No. PCT/US08/78963 filed on Oct. 6, 2008 (7 Pages).
- International Search Report and Written Opinion dated Jul. 30, 2014, for International Patent Application No. PCT/US14/21659, filed Mar. 7, 2014 (15 pages).
- International Search Report and Written Opinion dated Mar. 10, 2014, for International Patent Application No. PCT/US2013/076212, filed Dec. 18, 2013 (8 pages).
- International Search Report and Written Opinion dated Mar. 11, 2014, for International Patent Application No. PCT/US13/76173, filed Dec. 16, 2013 (9 pages).
- International Search Report and Written Opinion dated Mar. 11, 2014, for International Patent Application No. PCT/US13/76449, filed Dec. 19, 2013 (9 pages).
- International Search Report and Written Opinion dated Mar. 18, 2014, for International Patent Application No. PCT/US2013/076502, filed Dec. 19, 2013 (7 pages).
- International Search Report and Written Opinion dated Mar. 18, 2014, for International Patent Application No. PCT/US2013/076788, filed Dec. 20, 2013 (7 pages).
- International Search Report and Written Opinion dated Mar. 19, 2014, for International Patent Application No. PCT/US13/75349, filed Dec. 16, 2013 (10 pages).
- International Search Report and Written Opinion dated Mar. 19, 2014, for International Patent Application No. PCT/US2013/076587, filed Dec. 19, 2013 (10 pages).
- International Search Report and Written Opinion dated Mar. 19, 2014, for International Patent Application No. PCT/US2013/076909, filed Dec. 20, 2013 (7 pages).
- International Search Report and Written Opinion dated Mar. 7, 2014, for International Patent Application No. PCT/US2013/076304, filed Dec. 18, 2013 (9 pages).
- International Search Report and Written Opinion dated Mar. 7, 2014, for International Patent Application No. PCT/US2013/076480, filed Dec. 19, 2013 (8 pages).
- International Search Report and Written Opinion dated Mar. 7, 2014, for International Patent Application No. PCT/US2013/076512, filed Dec. 19, 2013 (8 pages).
- International Search Report and Written Opinion dated Mar. 7, 2014, for International Patent Application No. PCT/US2013/076531, filed Dec. 19, 2013 (10 pages).
- Jakobovits et al., 1993, Analysis of homozygous mutant chimeric mice: deletion of the immunoglobulin heavy-chain joining region blocks B-cell development and antibody production, *PNAS USA* 90:2551-2555.
- Jakobovits et al., 1993, Germ-line transmission and expression of a human-derived yeast artificial chromosome, *Nature* 362:255-258.
- Jang et al., 2002, Visualization of Coronary Atherosclerotic Plaques in Patients Using Optical Coherence Tomography: Comparison With Intravascular Ultrasound, *Journal of the American College of Cardiology* 39:604-609.
- Jiang et al., 1992, Image registration of multimodality 3-D medical images by chamfer matching, *Proc. SPIE 1660, Biomedical Image Processing and Three-Dimensional Microscopy*, 356-366.
- Johnson et al., 1993, Human antibody engineering: Current Opinion in Structural Biology, 3:564-571.
- Jones et al., 1986, Replacing the complementarity-determining regions in a human antibody with those from a mouse, *Nature*, 321:522-525.
- Juviler et al., 2008, Anorectal sepsis and fistula-in-ano, *Surgical Technology International*, 17:139-149.
- Karapatis et al., 1998, Direct rapid tooling: a review of current research, *Rapid Prototyping Journal*, 4(2):77-89.
- Karp et al., 2009, The benefit of time-of-flight in PET imaging, *J Nucl Med* 49:462-470.
- Kelly et al., 2005, Detection of Vascular Adhesion Molecule-1 Expression Using a Novel Multimodal Nanoparticle, *Circulation Research* 96:327-336.
- Kemp et al., 2005, Depth Resolved Optic Axis Orientation in Multiple Layered Anisotropic Tissues Measured with Enhanced Polarization Sensitive Optical Coherence Tomography, *Optics Express* 13(12):4507-4518.

(56)

References Cited

OTHER PUBLICATIONS

- Kersey et al., 1991, Polarization insensitive fiber optic Michelson interferometer, *Electron. Lett.* 27:518-520.
- Kheir et al., 2012, Oxygen Gas-Filled Microparticles Provide Intravenous Oxygen Delivery, *Science Translational Medicine* 4(140):140ra88 (10 pages).
- Khuri-Yakub et al., 2011, Capacitive micromachined ultrasonic transducers for medical imaging and therapy, *J Micromech Microeng.* 21(5):054004-054014.
- Kirkman, 1991, Technique for flow reduction in dialysis access fistulas, *Surg Gyn Obstet.* 172(3):231-3.
- Kohler et al., 1975, Continuous cultures of fused cells secreting antibody of predefined specificity, *Nature*, 256:495-7.
- Koo et al., 2011, Diagnosis of Ischemia Causing Coronary Stenoses by Noninvasive Fractional Flow Reserve Computed From Coronary Computed Tomographic Angiograms, *J Am Coll Cardiol* 58(19):1989-1997.
- Kozbor et al., 1984, A human hybrid myeloma for production of human monoclonal antibodies, *J. Immunol.*, 133:3001-3005.
- Kruth et al., 2003, Lasers and materials in selective laser sintering, *Assembly Automation*, 23(4):357-371.
- Kumagai et al., 1994, Ablation of polymer films by a femtosecond high-peak-power Ti:sapphire laser at 798 nm, *Appl Phys Letters*, 65(14):1850-1852.
- Larin et al., 2002, Noninvasive Blood Glucose Monitoring with Optical Coherence Tomography: a pilot study in human subjects, *Diabetes Care*, 25(12):2263-7.
- Larin et al., 2004, Measurement of Refractive Index Variation of Physiological Analytes using Differential Phase OCT, *Proc of SPIE* 5325:31-34.
- Laufer, 1996, *Introduction to Optics and Lasers in Engineering*, Cambridge University Press, Cambridge UK:156-162.
- Lefevre et al., 2001, Stenting of bifurcation lesions: a rational approach, *J. Interv. Cardiol.*, 14(6):573-585.
- Li et al., 2000, Optical Coherence Tomography: Advanced Technology for the Endoscopic Imaging of Barrett's Esophagus, *Endoscopy*, 32(12):921-930.
- Little et al., 1991, The underlying coronary lesion in myocardial infarction: implications for coronary angiography, *Clinical Cardiology*, 14(11):868-874.
- Loo, 2004, Nanoshell Enabled Photonics-Based Imaging and Therapy of Cancer, *Technology in Cancer Research & Treatment* 3(1):33-40.
- Maintz et al., 1998, An Overview of Medical Image Registration Methods, Technical Report UU-CS, (22 pages).
- Mamas et al., 2010, Resting Pd/Pa measured with intracoronary pressure wire strongly predicts fractional flow reserve, *Journal of Invasive Cardiology* 22(6):260-265.
- Marks et al., 1991, By-passing Immunization Human Antibodies from V-gene Libraries Displayed on Phage, *J. Mol. Biol.* 222:581-597.
- Marks et al., 1992, By-Passing Immunization: Building High Affinity Human Antibodies by Chain Shuffling, *BioTechnol.*, 10:779-783.
- Maruno et al., 1991, Fluorine containing optical adhesives for optical communications systems, *J. Appl. Polymer. Sci.* 42:2141-2148.
- McCafferty et al., 1990, Phage antibodies: filamentous phage displaying antibody variable domains, *Nature* 348:552-554.
- Mendieta et al., 1996, Complementary sequence correlations with applications to reflectometry studies, *Instrumentation and Development* 3(6):37-46.
- Mickley, 2008, Steal Syndrome-strategies to preserve vascular access and extremity, *Nephrol Dial Transplant* 23:19-24.
- Miller et al., 2010, The MILLER banding procedure is an effective method for treating dialysis-associated steal syndrome, *Kidney International* 77:359-366.
- Milstein et al., 1983, Hybrid hybridomas and their use in immunohistochemistry, *Nature* 305:537-540.
- Mindlin et al., 1936, A force at a point of a semi-infinite solid, *Physics*, 7:195-202.
- Morrison et al., 1984, Chimeric human antibody molecules: mouse antigen-binding domains with human constant region domains, *PNAS* 81:6851-6855.
- Munson et al., 1980, Ligand: a versatile computerized approach for characterization of ligand-binding systems, *Analytical Biochemistry*, 107:220-239.
- Nezam, 2008, High Speed Polygon-Scanner-Based Wavelength-Swept Laser Source in the Telescope-Less Configurations with Application in Optical Coherence Tomography, *Optics Letters* 33(15):1741-1743.
- Nissen, 2001, Coronary Angiography and Intravascular Ultrasound, *American Journal of Cardiology*, 87(suppl):15A-20A.
- Nitenberg et al., 1995, Coronary vascular reserve in humans: a critical review of methods of evaluation and of interpretation of the results, *Eur Heart J.* 16(Suppl 1):7-21.
- Notice of Reason(s) for Refusal dated Apr. 30, 2013, for Japanese Patent Application No. 2011-508677 for Optical Imaging Catheter for Aberration Balancing to Volcano Corporation, which application is a Japanese national stage entry of PCT/US2009/043181 with international filing date May 7, 2009, of the same title, published on Nov. 12, 2009, as WO 2009/137704, and accompanying English translation of the Notice of Reason(s) for Refusal and machine translations of JP11-56786 and JP2004-290548 (56 pages).
- Nygren, 1982, Conjugation of horseradish peroxidase to Fab fragments with different homobifunctional and heterobifunctional cross-linking reagents. A comparative study, *J. Histochem. and Cytochem.* 30:407-412.
- Oesterle et al., 1986, Angioplasty at coronary bifurcations: single-guide, two-wire technique, *Cathet Cardiovasc Diagn.*, 12:57-63.
- Okuno et al., 2003, Recent Advances in Optical Switches Using Silica-based PLC Technology, *NTT Technical Review* 1(7):20-30.
- Oldenburg et al., 1998, Nanoengineering of Optical Resonances, *Chemical Physics Letters* 288:243-247.
- Oldenburg et al., 2003, Fast-Fourier-Domain Delay Line for In Vivo Optical Coherence Tomography with a Polygonal Scanner, *Applied Optics*, 42(22):4606-4611.
- Othonos, 1997, Fiber Bragg gratings, *Review of Scientific Instruments* 68(12):4309-4341.
- Owens et al., 2007, A Survey of General-Purpose Computation on Graphics Hardware, *Computer Graphics Forum* 26(1):80-113.
- Pain et al., 1981, Preparation of protein A-peroxidase mono conjugate using a heterobifunctional reagent, and its use in enzyme immunoassays, *J Immunol Methods*, 40:219-30.
- Park et al., 2005, Real-time fiber-based multi-functional spectral-domain optical coherence tomography at 1.3 μm , *Optics Express* 13(11):3931-3944.
- Pasquesi et al., 2006, In vivo detection of exercise induced ultrastructural changes in genetically-altered murine skeletal muscle using polarization-sensitive optical coherence tomography, *Optics Express* 14(4):1547-1556.
- Pepe et al., 2004, Limitations of the odds ratio in gauging the performance of a diagnostic, prognostic, or screening marker, *American Journal of Epidemiology* 159(9):882-890.
- Persson et al., 1985, Acoustic impedance matching of medical ultrasound transducers, *Ultrasonics*, 23(2):83-89.
- Placht et al., 2012, Fast time-of-flight camera based surface registration for radiotherapy patient positioning, *Medical Physics* 39(1):4-17.
- Rabbani et al., 1999, Review: Strategies to achieve coronary arterial plaque stabilization, *Cardiovascular Research* 41:402-417.
- Radvany et al., 2008, Plaque Excision in Management of Lower Extremity Peripheral Arterial Disease with the SilverHawk Atherectomy Catheter, *Seminars in Interventional Radiology*, 25(1):11-19.
- Reddy et al., 1996, An FFT-Based Technique for Translation, Rotation, and Scale-Invariant Image Registration, *IEEE Transaction on Image Processing* 5(8):1266-1271.
- Riechmann et al., 1988, Reshaping human antibodies for therapy, *Nature*, 332:323-327.
- Rivers et al., 1992, Correction of steal syndrome secondary to hemodialysis access fistulas: a simplified quantitative technique, *Surgery*, 112(3):593-7.
- Robbin et al., 2002, Hemodialysis Arteriovenous Fistula Maturity: US Evaluation, *Radiology* 225:59-64.

(56)

References Cited

OTHER PUBLICATIONS

- Rollins et al., 1998, In vivo video rate optical coherence tomography, *Optics Express* 3:219-229.
- Sarunic et al., 2005, Instantaneous Complex Conjugate Resolved Spectral Domain and Swept-Source OCT Using 3x3 Fiber Couplers, *Optics Express* 13(3):957-967.
- Satiani et al., 2009, Predicted Shortage of Vascular Surgeons in the United States, *J. Vascular Surgery* 50:946-952.
- Schneider et al., 2006, T-banding: A technique for flow reduction of a hyper-functioning arteriovenous fistula, *J Vase Surg.* 43(2):402-405.
- Sen et al., 2012, Development and validation of a new adenosine-independent index of stenosis severity from coronary wave-intensity analysis, *Journal of the American College of Cardiology* 59(15):1392-1402.
- Setta et al., 2005, Soft versus firm embryo transfer catheters for assisted reproduction: a systematic review and meta-analysis, *Human Reproduction*, 20(11):3114-3121.
- Seward et al., 1996, Ultrasound Cardioscopy: Embarking on New Journey, *Mayo Clinic Proceedings* 71(7):629-635.
- Shen et al., 2006, Eigengene-based linear discriminant model for tumor classification using gene expression microarray data, *Bioinformatics* 22(21):2635-2642.
- Sihan et al., 2008, A novel approach to quantitative analysis of intraluminal optical coherence tomography imaging, *Comput. Cardiol*:1089-1092.
- Sivy et al., 2003, Electro-responsive asymmetric nanopores in polyimide with stable ion-current signal, *Applied Physics A: Materials Science & Processing* 76:781-785.
- Smith et al., 1989, Absolute displacement measurements using modulation of the spectrum of white light in a Michelson interferometer, *Applied Optics*, 28(16):3339-3342.
- Smith, 1997, *The Scientist and Engineer's Guide to Digital Signal Processing*, California Technical Publishing, San Diego, CA:432-436.
- Soller, 2003, Polarization diverse optical frequency domain interferometry: All coupler implementation, Bragg Grating, Photosensitivity, and Poling in Glass Waveguides Conference MB4:30-32.
- Song et al., 2012, Active tremor cancellation by a "Smart" handheld vitreoretinal microsurgical tool using swept source optical coherence tomography, *Optics Express*, 20(21):23414-23421.
- Stenqvist et al., 1983, Stiffness of central venous catheters, *Acta Anaesthesiol Scand.*, 2:153-157.
- Strickland, 1970, *Time-Domain Reflectometer Measurements*, Tektronix, Beaverton, OR, (107 pages).
- Strobl et al., 2009, An Introduction to Recursive Partitioning: Rationale, Application and Characteristics of Classification and Regression Trees, Bagging and Random Forests, *Psychol Methods.*, 14(4):323-348.
- Sutcliffe et al., 1986, Dynamics of UV laser ablation of organic polymer surfaces, *Journal of Applied Physics*, 60(9):3315-3322.
- Suzuki, 2013, A novel guidewire approach for handling acute-angle bifurcations, *J Inv Cardiol* 25(1):48-54.
- Tanimoto et al., 2008, A novel approach for quantitative analysis of intracoronary optical coherence tomography: high inter-observer agreement with computer-assisted contour detection, *Cathet Cardiovascular Intervent.*, 72(2):228-235.
- Tearney et al., 1997, In vivo Endoscopic Optical Biopsy with Optical Coherence Tomography, *Science*, 276:2037-2039.
- Tonino et al., 2009, Fractional flow reserve versus angiography for guiding percutaneous coronary intervention, *The New England Journal of Medicine*, 360:213-224.
- Toregeani et al., 2008, Evaluation of hemodialysis arteriovenous fistula maturation by color-flow Doppler ultrasound, *J Vasc. Bras.* 7(3):203-213.
- Trauneker et al., 1991, Bispecific single chain molecules (Janusins) target cytotoxic lymphocytes on HIV infected cells *EMBO J.*, 10:3655-3659.
- Trolier-McKinstry et al., 2004, Thin Film Piezoelectric for MEMS, *Journal of Electroceramics* 12:7-17.
- Tuniz et al., 2010, Weaving the invisible thread: design of an optically invisible metamaterial fibre, *Optics Express* 18(17):18095-18105.
- Turk et al., 1991, Eigenfaces for Recognition, *Journal of Cognitive Neuroscience* 3(1):71-86.
- Tuzel et al., 2006, Region Covariance: A Fast Descriptor for Detection and Classification, *European Conference on Computer Vision (ECCV)*.
- Urban et al., 2010, Design of a Pressure Sensor Based on Optical Bragg Grating Lateral Deformation, *Sensors (Basel)*, 10(12):11212-11225.
- Vakhtin et al., 2003, Common-path interferometer for frequency-domain optical coherence tomography, *Applied Optics*, 42(34):6953-6958.
- Vakoc et al., 2005, Phase-Resolved Optical Frequency Domain Imaging, *Optics Express* 13(14):5483-5493.
- Verhoeven et al., 1988, Reshaping human antibodies: grafting an antilysozyme activity, *Science*, 239:1534-1536.
- Villard et al., 2002, Use of a blood substitute to determine instantaneous murine right ventricular thickening with optical coherence tomography, *Circulation*, 105:1843-1849.
- Wang et al., 2002, Optimizing the Beam Pattern of a Forward-Viewing Ring-Annular Ultrasound Array for Intravascular Imaging, *Transactions on Ultrasonics, Ferroelectrics, and Frequency Control*, 49(12).
- Wang et al., 2006, Multiple biomarkers for the prediction of first major cardiovascular events and death, *The New England Journal of Medicine*, 355(25):2631-2639.
- Wang et al., 2009, Robust Guidewire Tracking in Fluoroscopy, *IEEE Conference on Computer Vision and Pattern Recognition—CVPR 2009*:691-698.
- Wang et al., 2011, In vivo intracardiac optical coherence tomography imaging through percutaneous access: toward image-guided radio-frequency ablation, *J. Biomed. Opt.* 16(11):110505-1 (3 pages).
- Waterhouse et al., 1993, Combinatorial infection and in vivo recombination: a strategy for making large phage antibody repertoires, *Nucleic Acids Res.*, 21:2265-2266.
- Wegener, 2011, *3D Photonic Metamaterials and Invisibility Cloaks: The Method of Making*, MEMS 2011, Cancun, Mexico, Jan. 23-27, 2011.
- West et al., 1991, Arterial insufficiency in hemodialysis access procedures: correction by banding technique, *Transpl Proc* 23(2):1838-40.
- Wyawahare et al., 2009, Image registration techniques: an overview, *International Journal of Signal Processing, Image Processing and Pattern Recognition*, 2(3):11-28.
- Yaqoob et al., 2006, Methods and application areas of endoscopic optical coherence tomography, *J. Biomed. Opt.*, 11, 063001-1-063001-19.
- Yasuno et al., 2004, Polarization-sensitive complex Fourier domain optical coherence tomography for Jones matrix imaging of biological samples, *Applied Physics Letters* 85(15):3023-3025.
- Zhang et al., 2004, Full range polarization-sensitive Fourier domain optical coherence tomography, *Optics Express*, 12(24):6033-6039.
- Zitova et al., 2003, Image registration methods: A survey. *Image and Vision Computing*, 21(11):977-1000.
- Machine translation of JP 2000-329534.
- Machine translation of JP 2004-004080.
- Machine translation of JP 2000-097846.
- Machine translation of JP 2000-321034.
- Translation of Notice of Reason(s) for Refusal dated Apr. 30, 2014, for Japanese Patent Application No. 2011-508677, (5 pages).
- Translation of Notice of Reason(s) for Refusal dated Nov. 22, 2012, for Japanese Patent Application No. 2010-516304, (6 pages).
- International Search Report dated Mar. 21, 2014 for International Application No. PCT/US13/63522 filed Oct. 4, 2013 (5 pages).
- Translation of Notice of Reason(s) for Refusal dated May 25, 2012, for Japanese Patent Application No. 2009-536425, (3 pages).

(56)

References Cited

OTHER PUBLICATIONS

Siemens, "Navigator syngo Operator Manual SOMATOM Emotion Duo Version A40A", Jan. 2000.

* cited by examiner

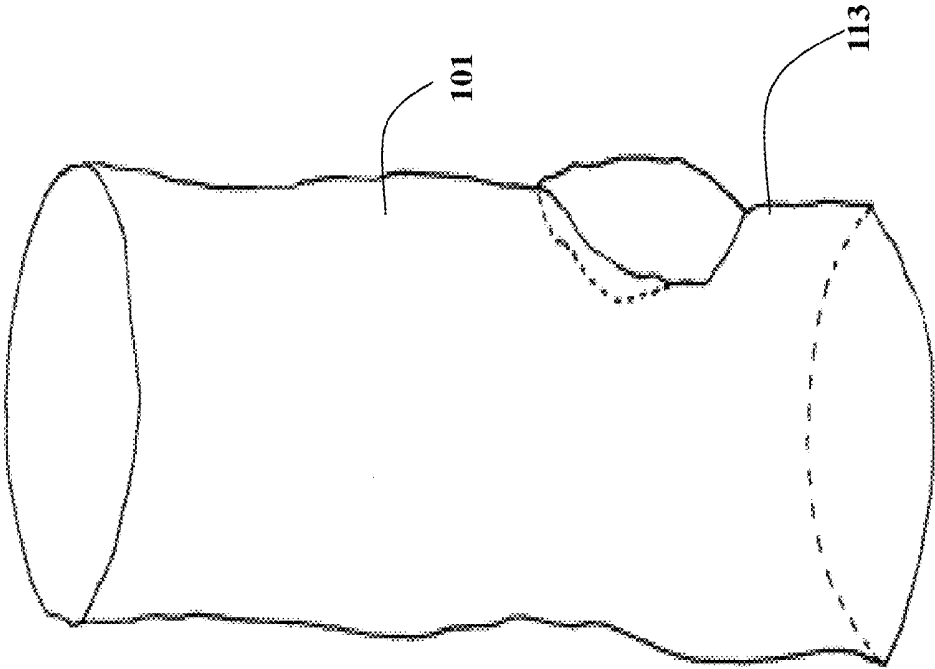

FIG. 1

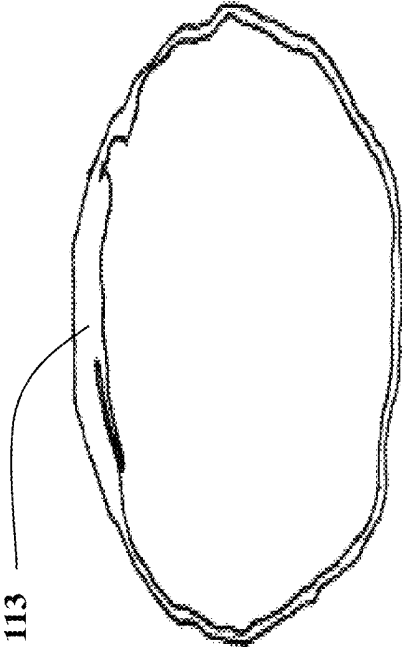

FIG. 2

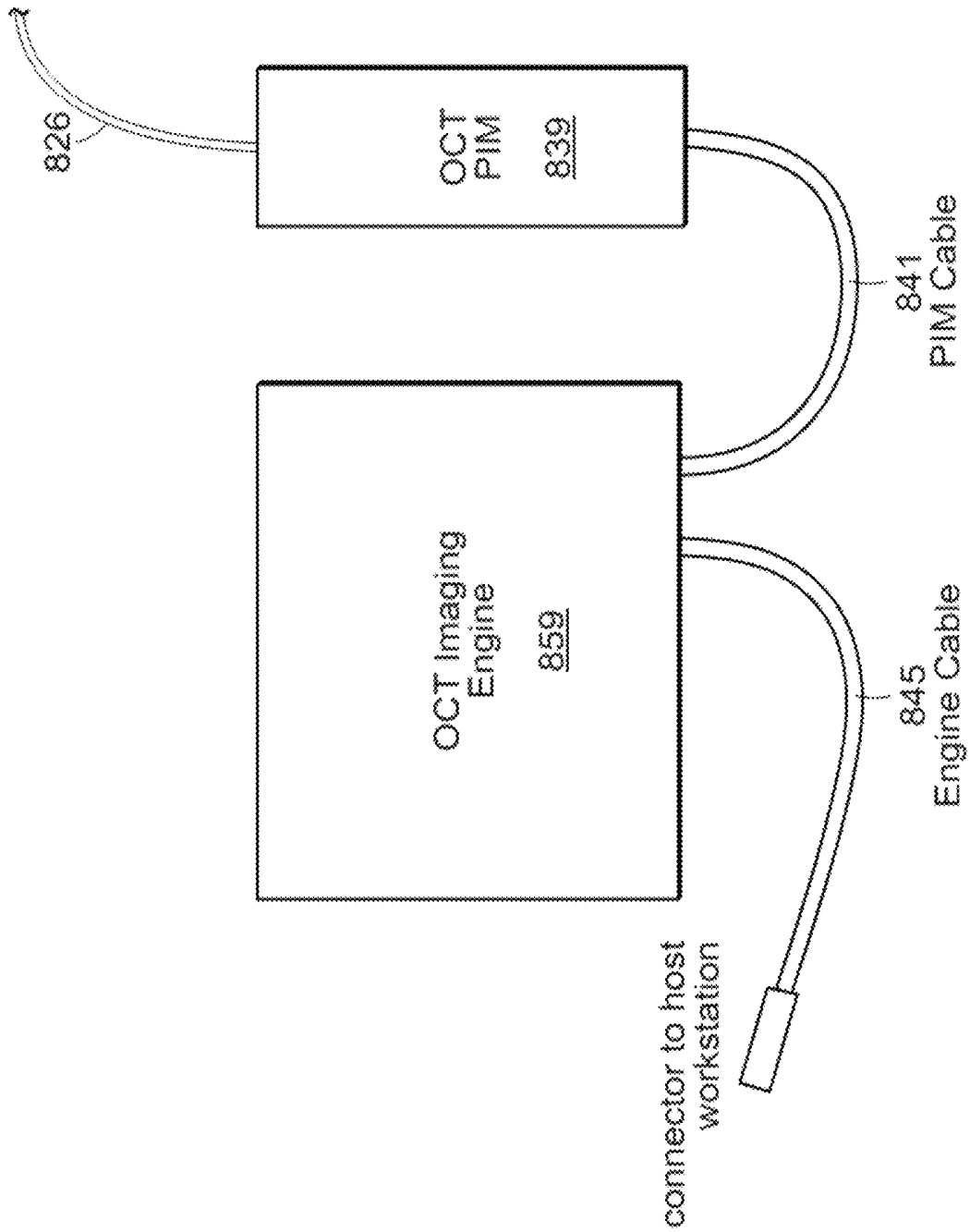

FIG. 3

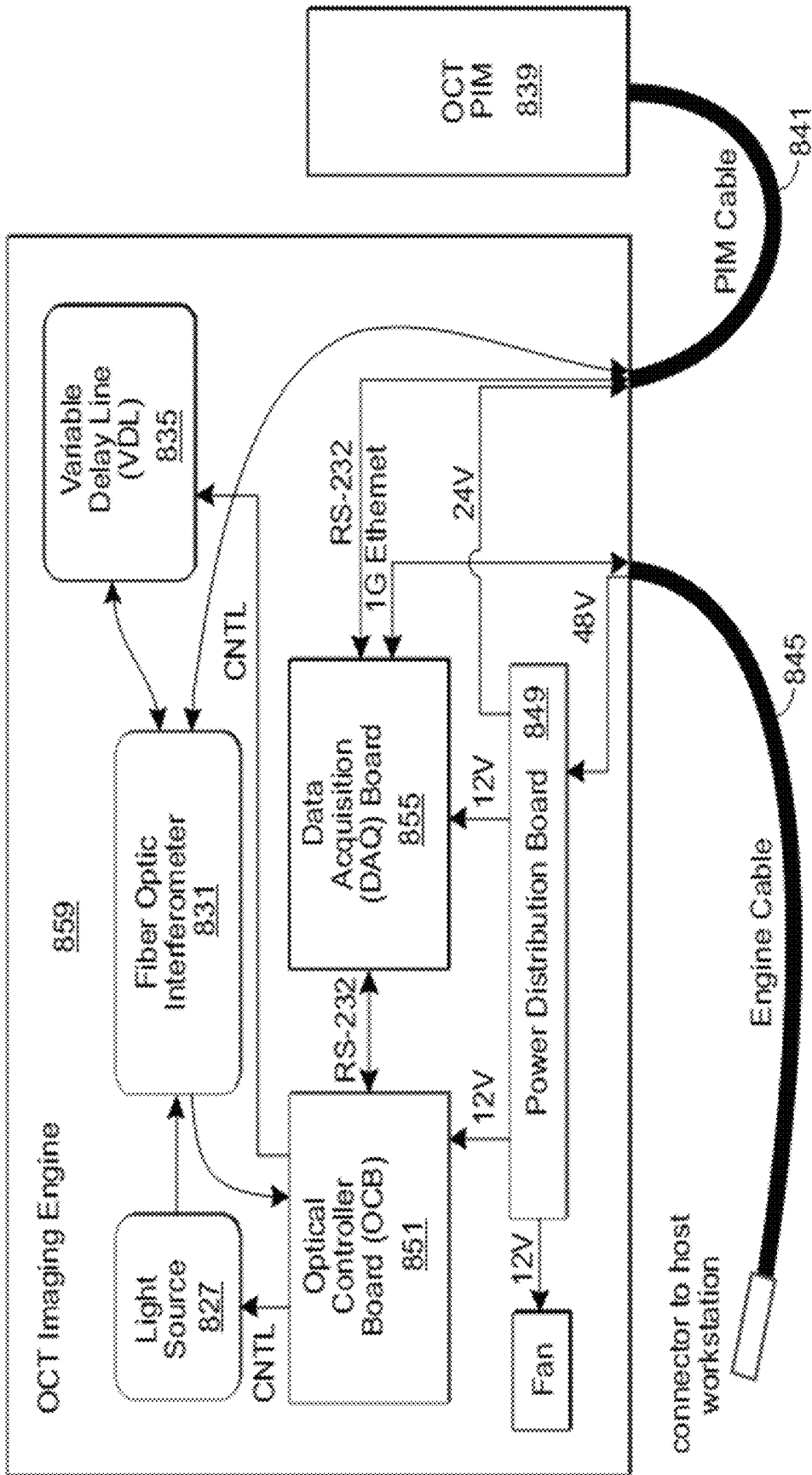

FIG. 4

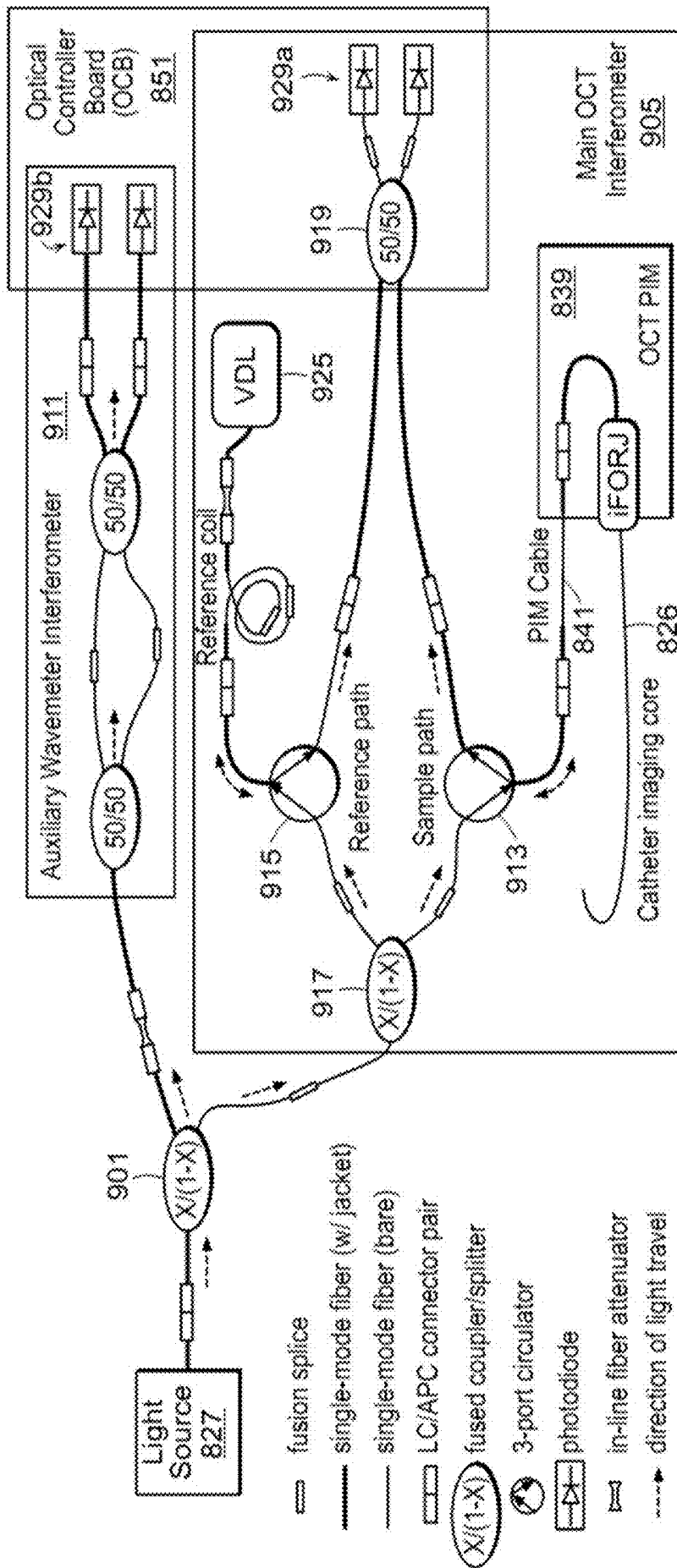

FIG. 5

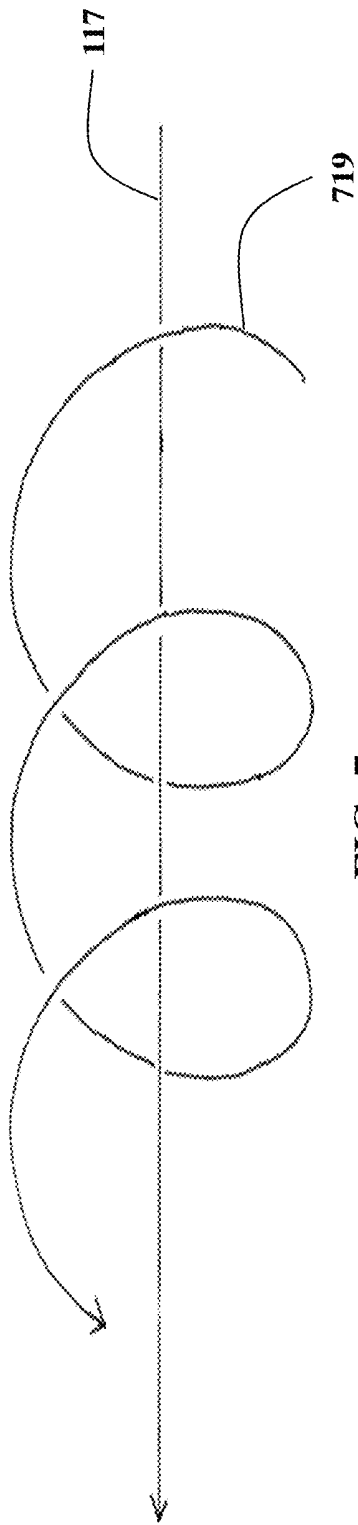

FIG. 7

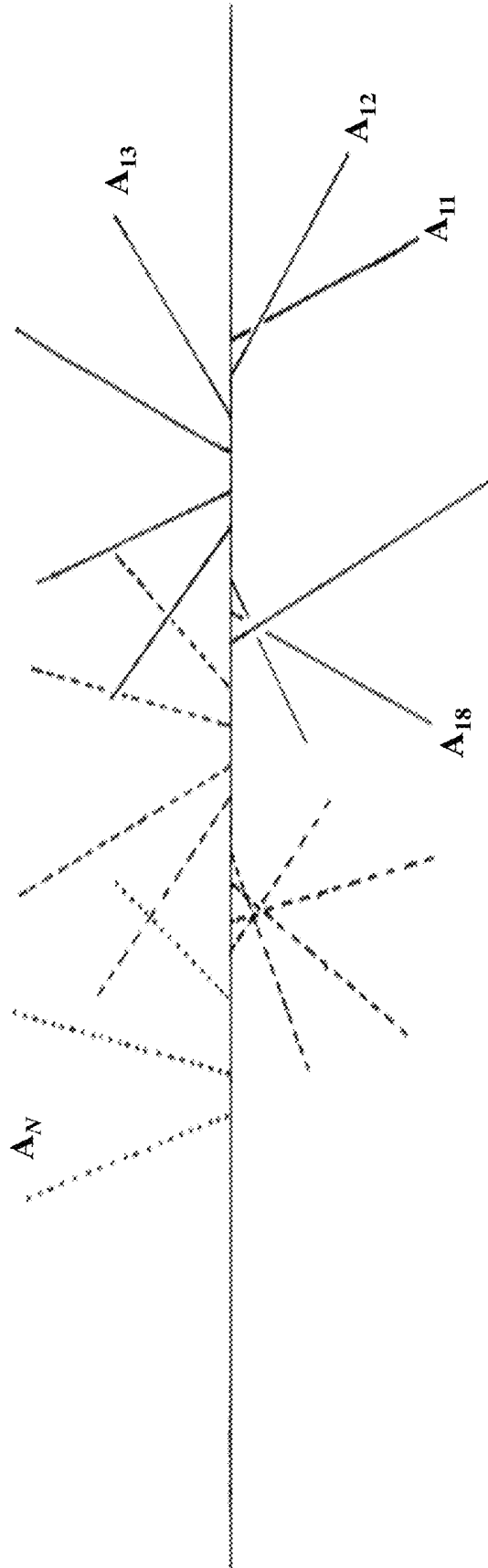

FIG. 8

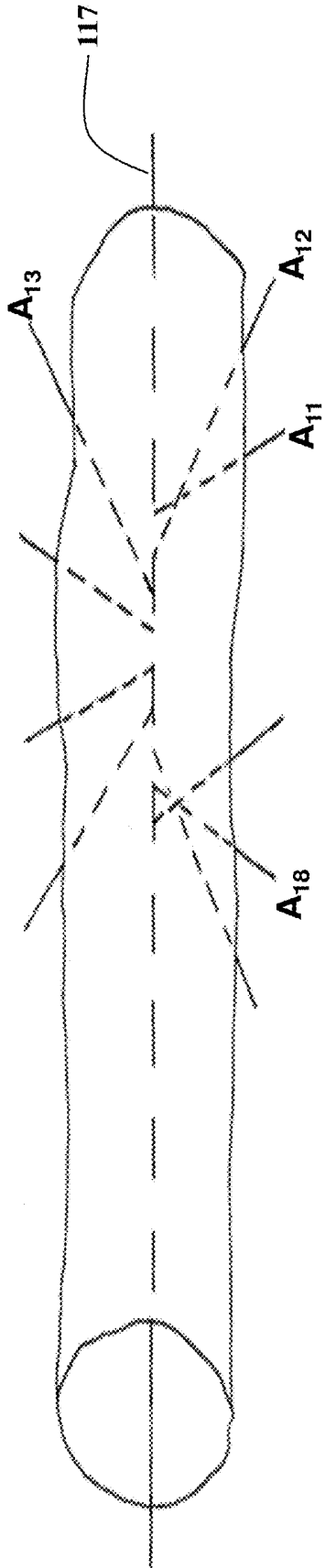

FIG. 9

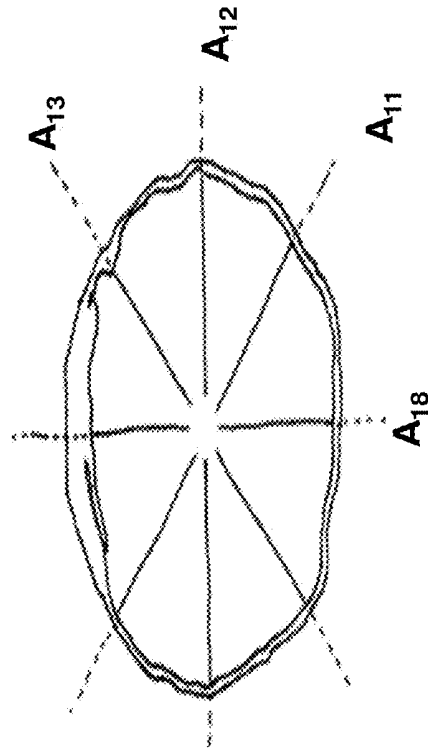

FIG. 11

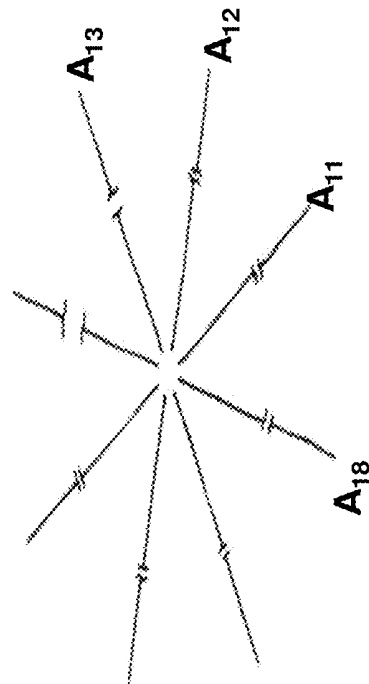

FIG. 10

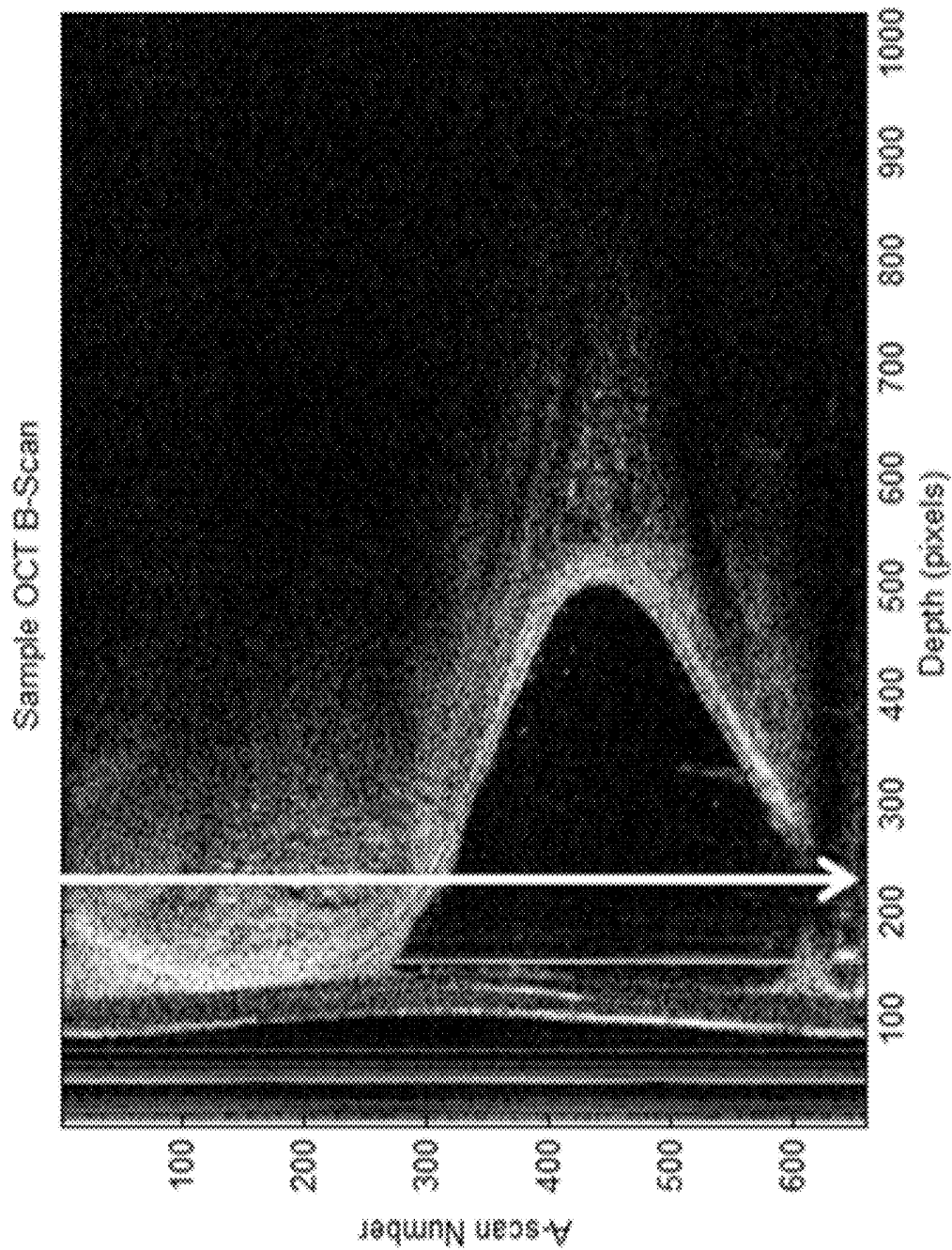

FIG. 12

Scan Converted Example

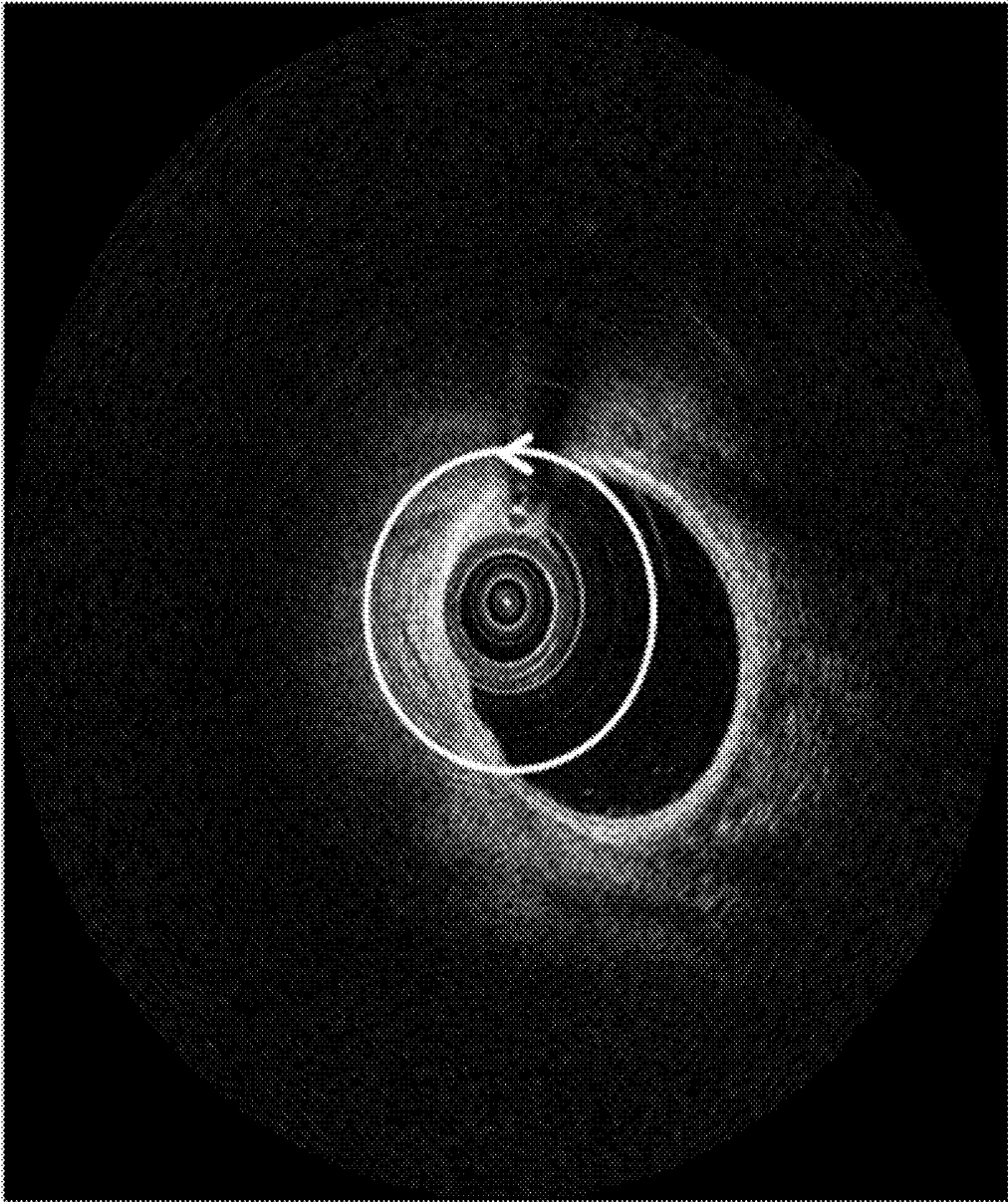

FIG. 13

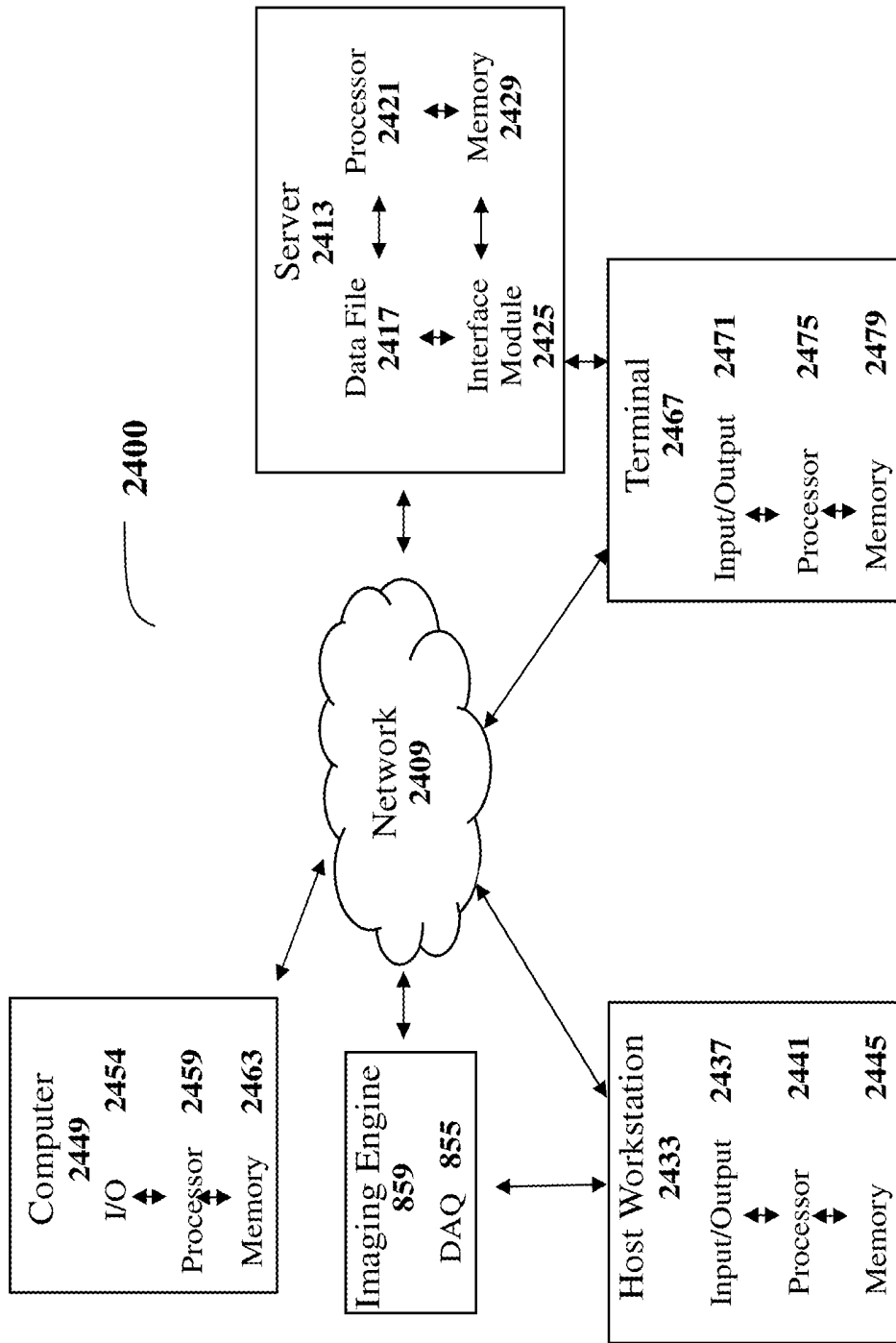

FIG. 14

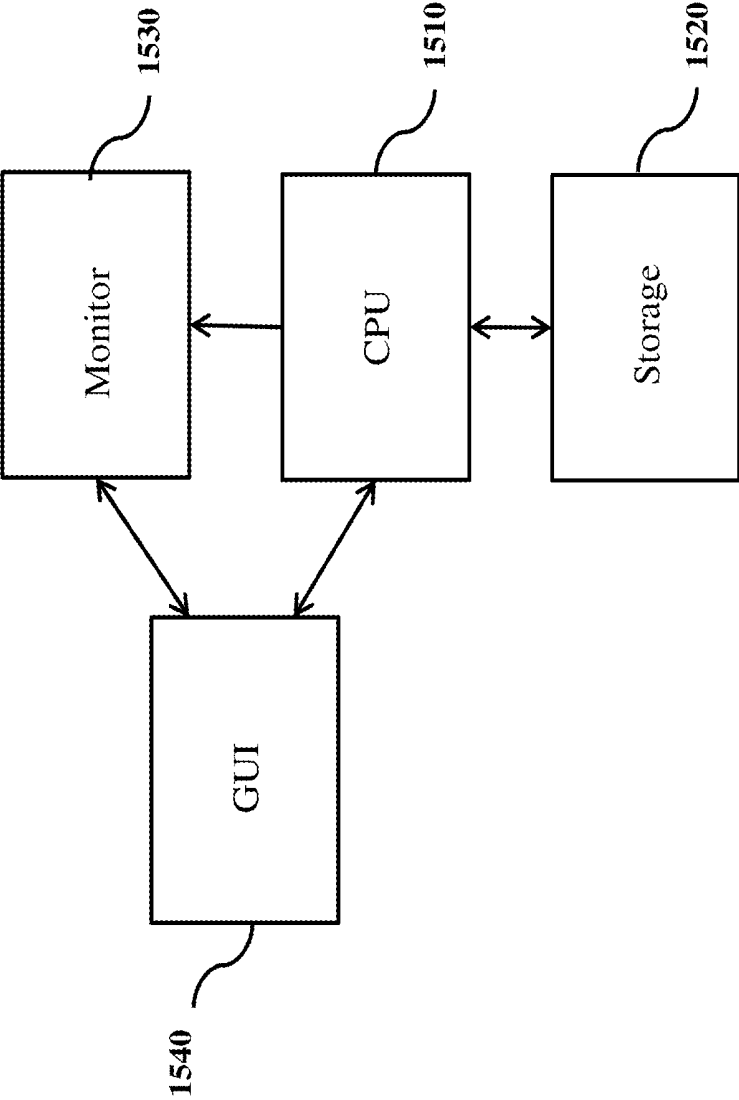

FIG. 15

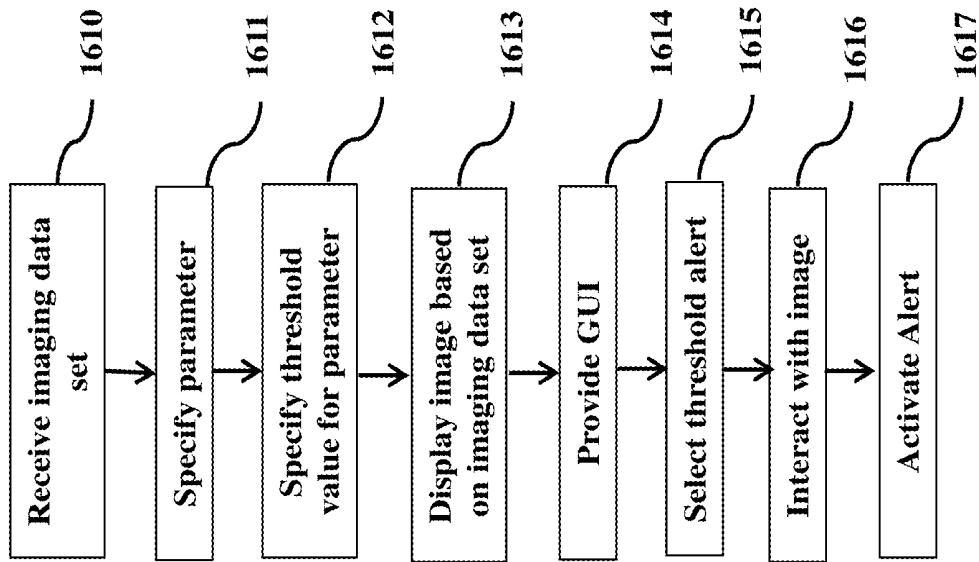

FIG. 16B

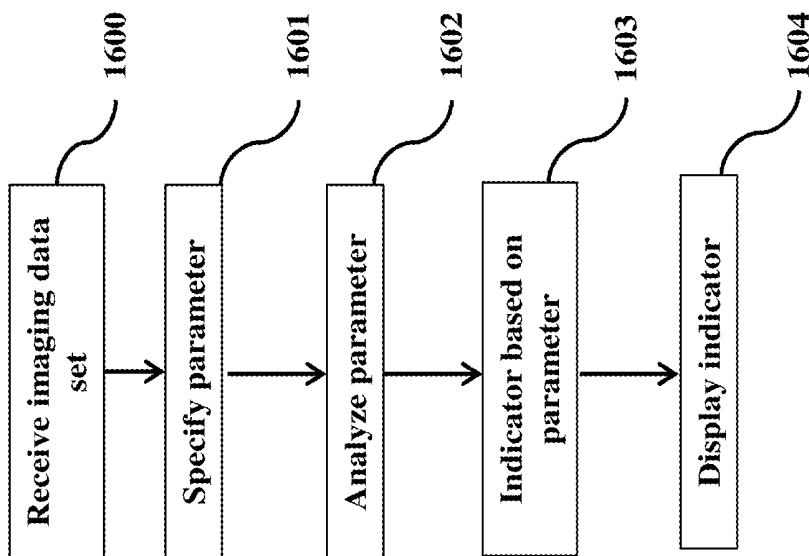

FIG. 16A

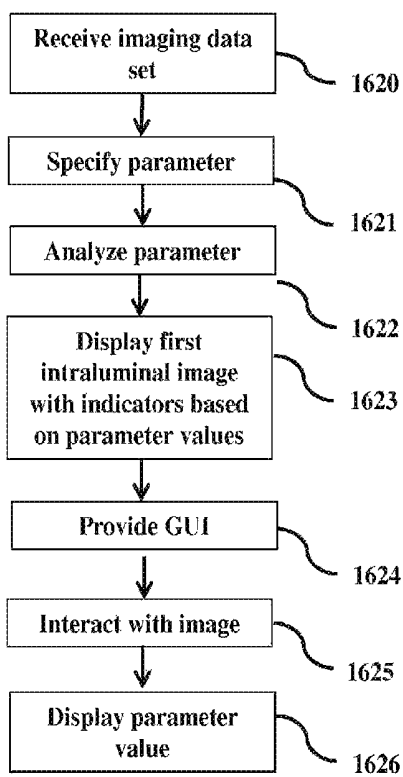

FIG. 16C

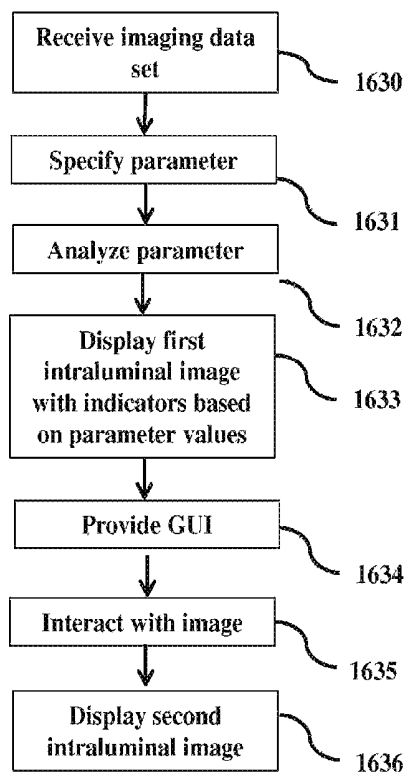

FIG. 16D

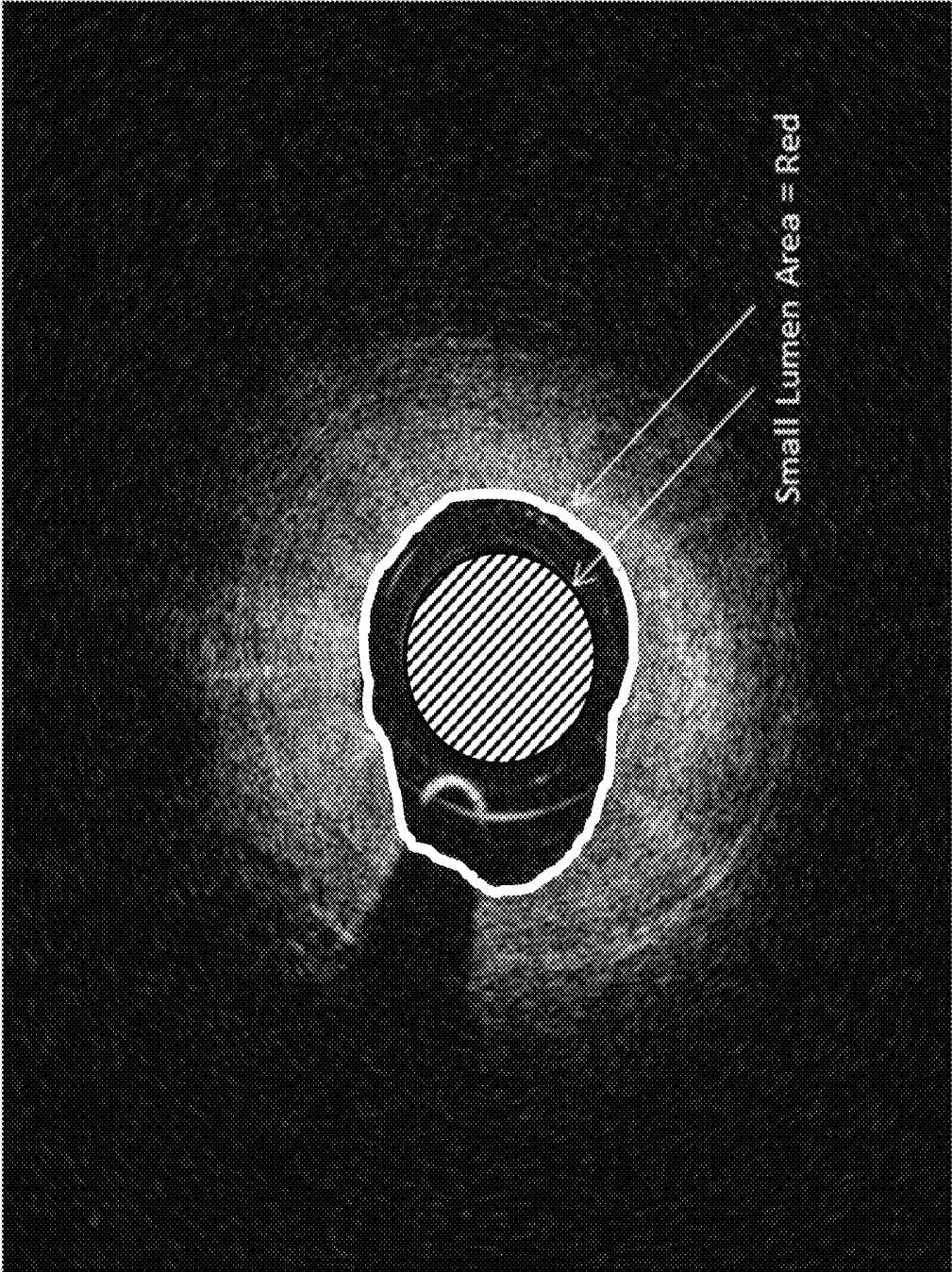

FIG. 17

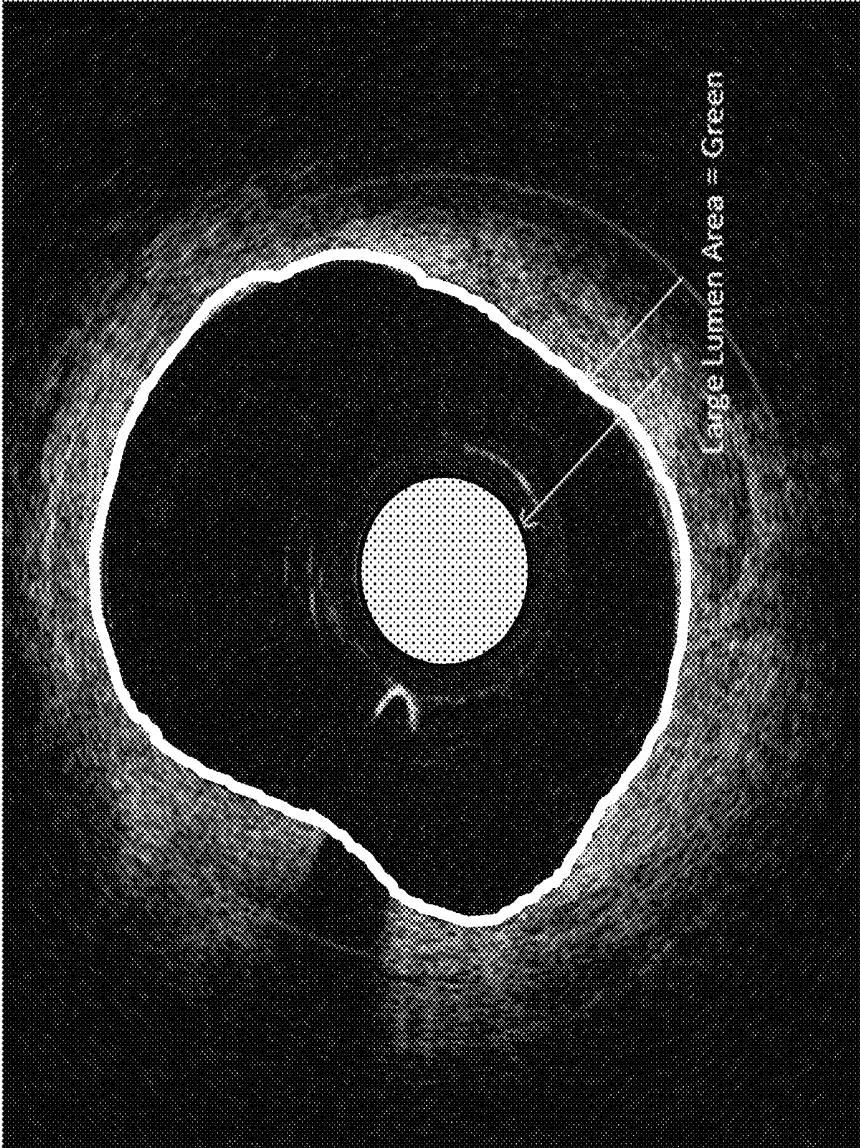

FIG. 18

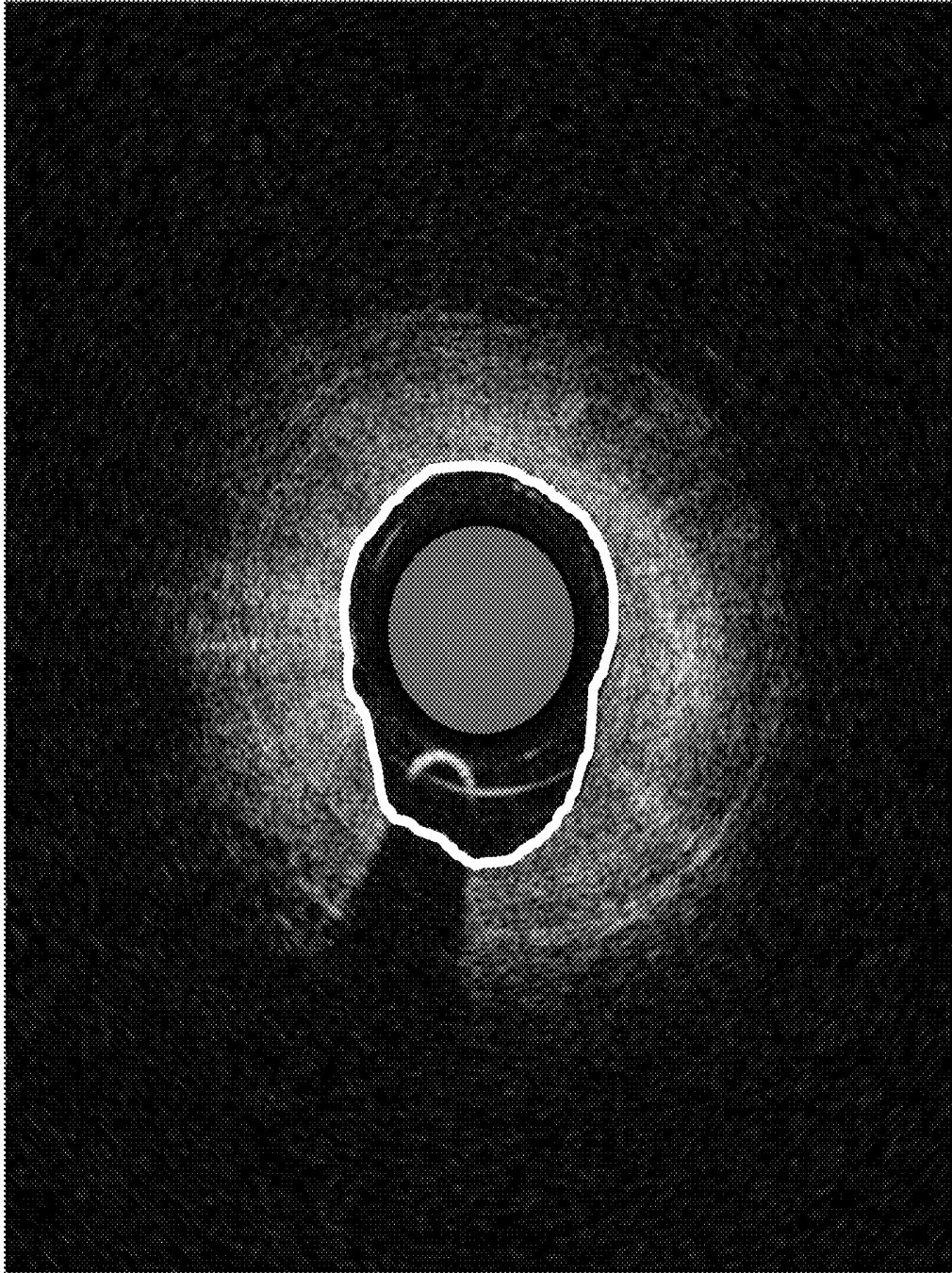

FIG. 19

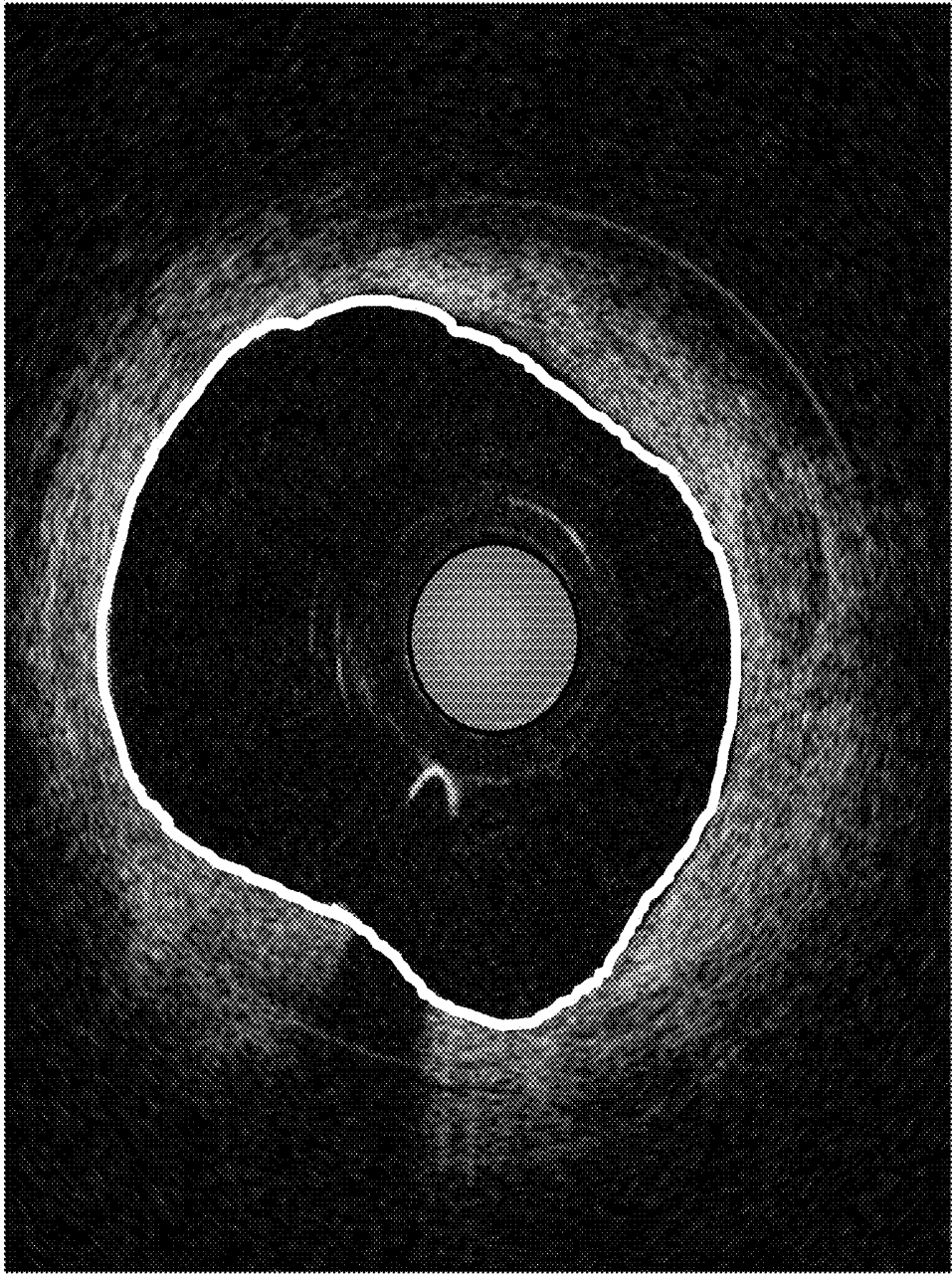

FIG. 20

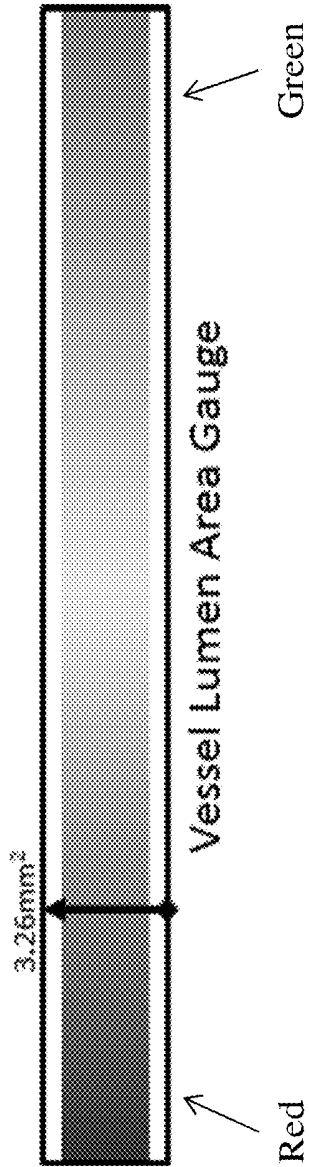

FIG. 21A

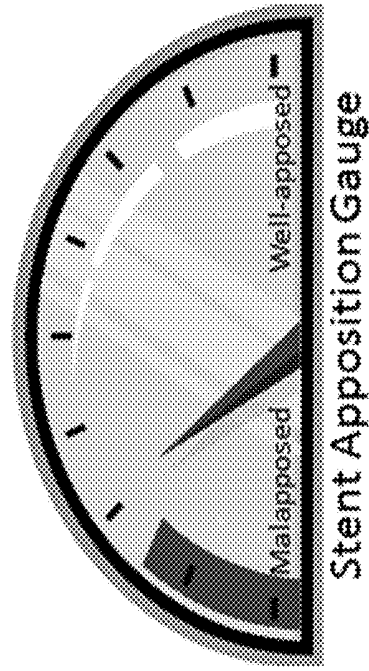
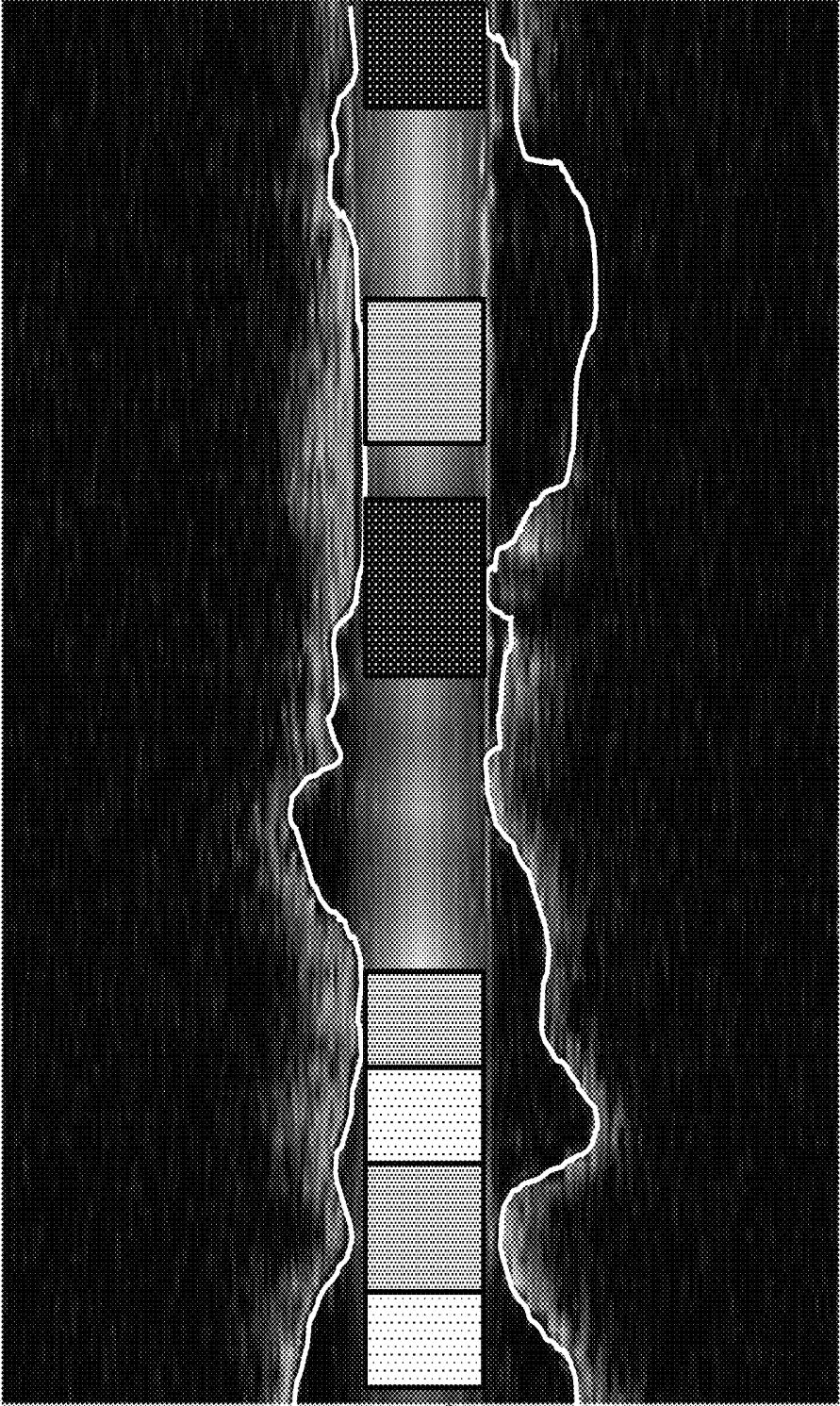

FIG. 21B

Frames



Depth

FIG. 22

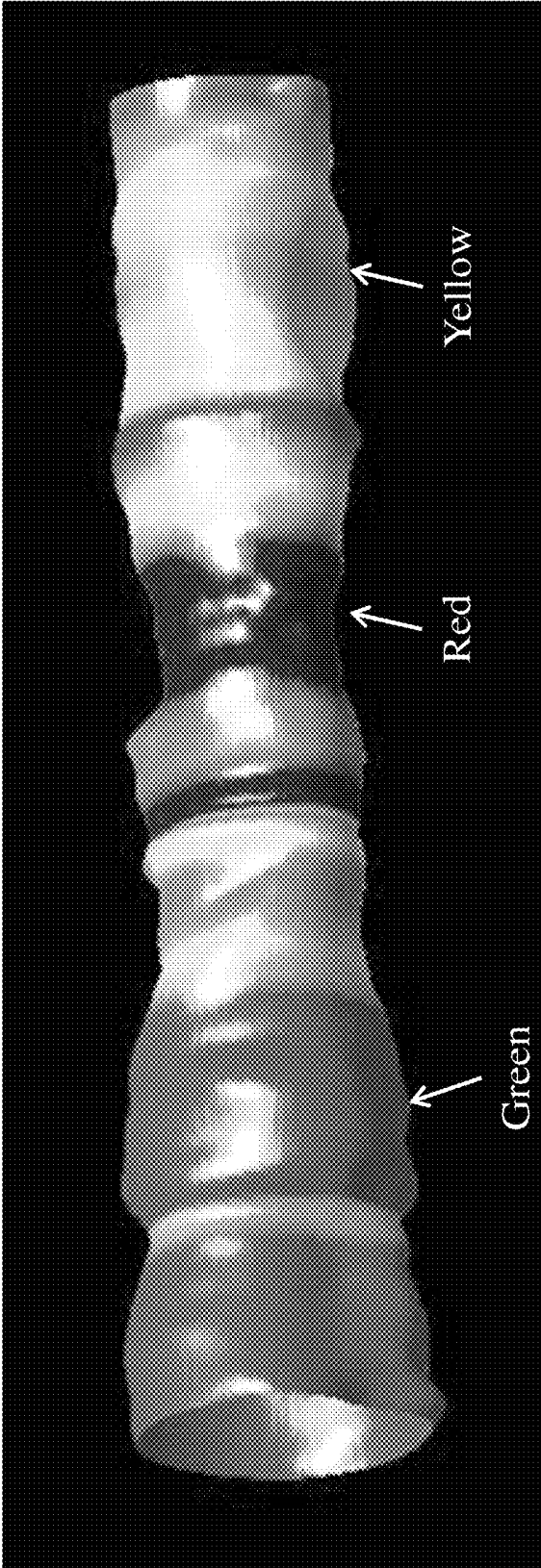

FIG. 23

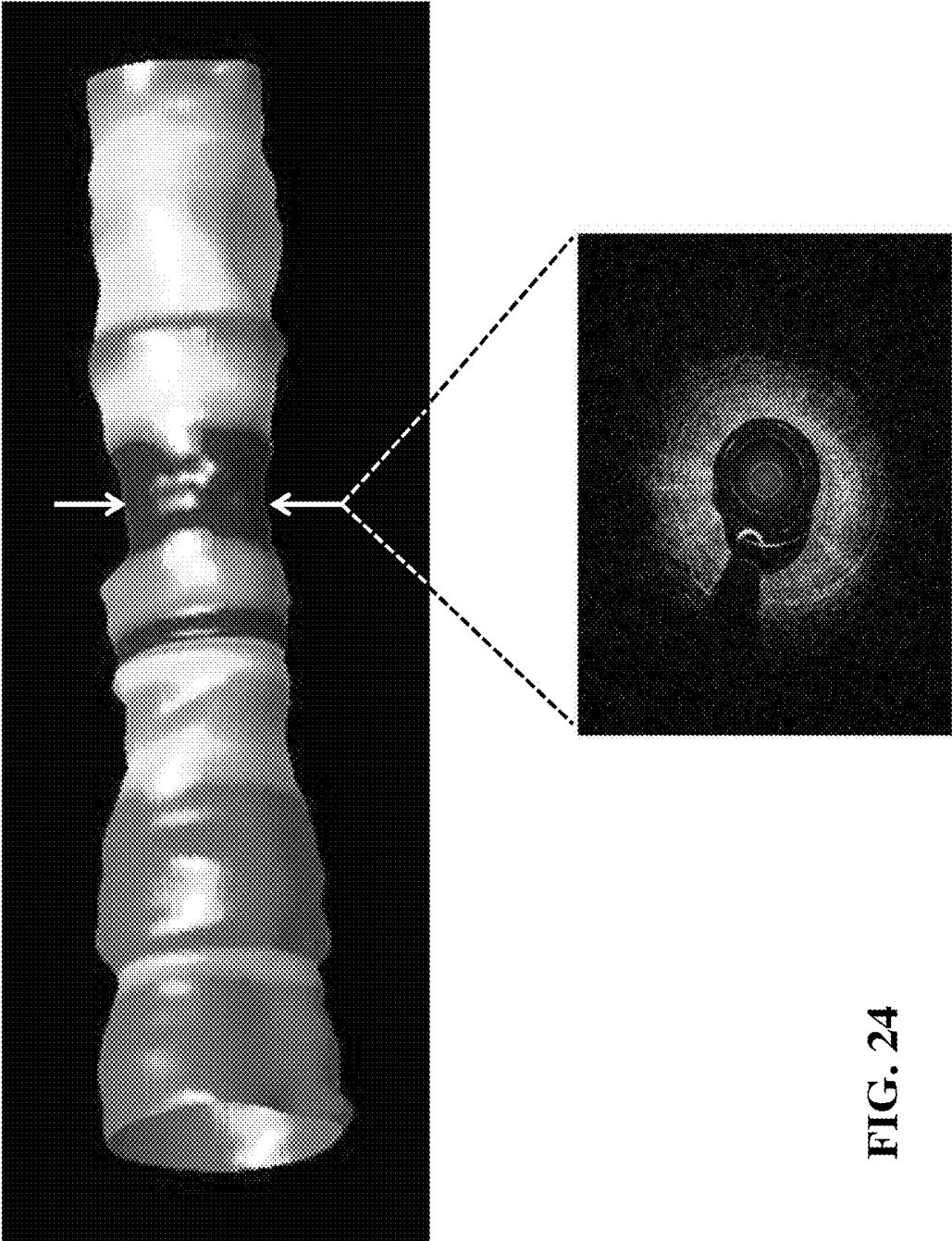

FIG. 24

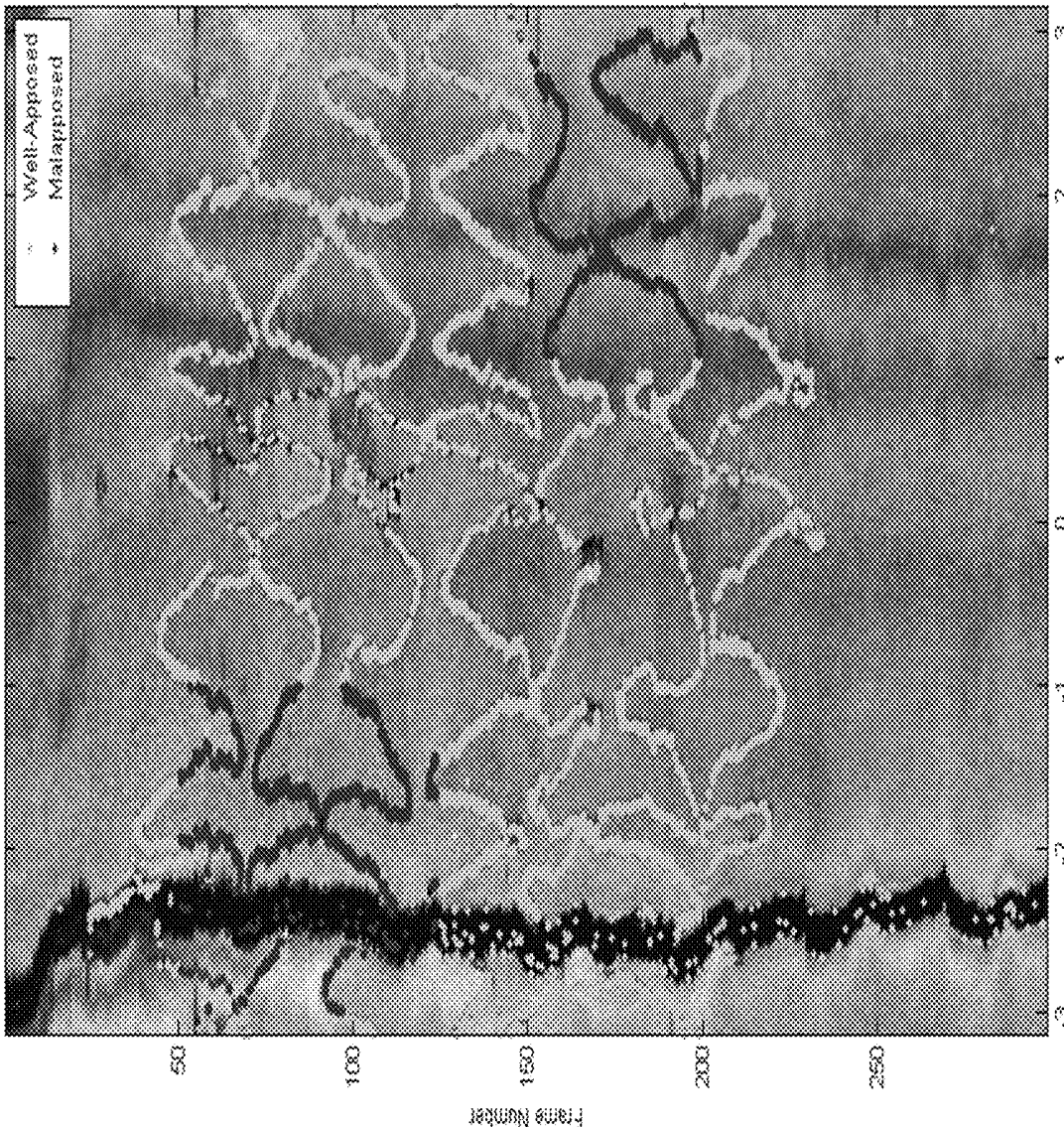

FIG. 25



FIG. 26

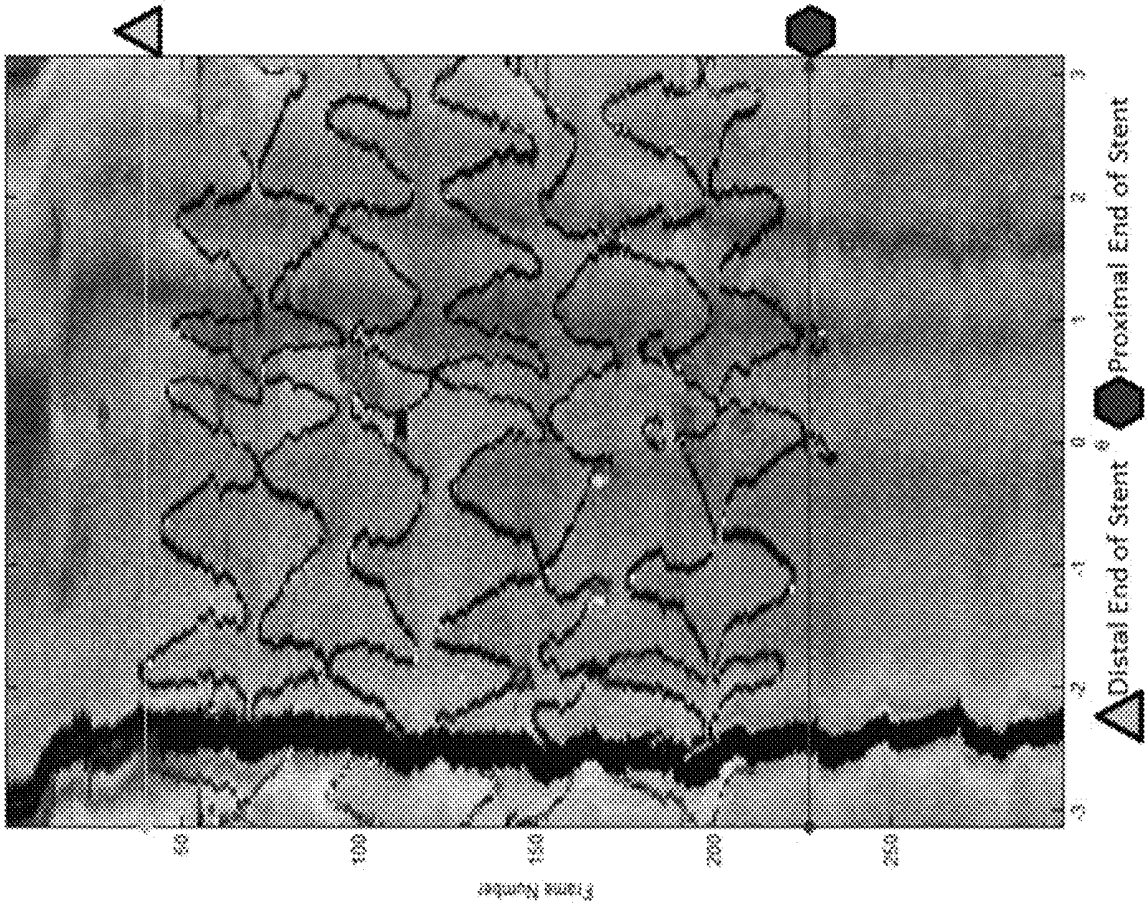

FIG. 27

SYSTEMS FOR INDICATING PARAMETERS IN AN IMAGING DATA SET AND METHODS OF USE

STATEMENT OF RELATED APPLICATIONS

This application claims priority to U.S. Provisional Patent Application No. 61/710,419, filed Oct. 5, 2012, which is incorporated herein by reference in its entirety.

FIELD OF THE INVENTION

The invention generally relates to systems for indicating parameters in an imaging data set, for example, an imaging data set relating to a medical device or a biological lumen.

BACKGROUND

Tomographic imaging is a signal acquisition and processing technology that allows for high-resolution cross-sectional imaging in biological systems. Tomographic imaging systems include, for example, optical coherence tomography systems, ultrasound imaging systems, and computed tomography. Tomographic imaging is particularly well-suited for imaging the subsurface of a vessel or lumen within the body, such as a blood vessel, using probes disposed within a catheter through a minimally invasive procedure.

Typical tomographic imaging catheters consist of an imaging core that rotates and moves longitudinally through a blood vessel, while recording an image video loop of the vessel. The motion results in a 3D dataset, where each frame provides a 360 degree slice of the vessel at different longitudinal section. These frames provide cardiologists with invaluable information such as the location and severity of the stenosis in a patient, the presence of vulnerable plaques, and changes in cardiovascular disease over time. The information also assists in determining the appropriate treatment plan for the patient, such as drug therapy, stent placement, angioplasty, bypass surgery, valve replacement, etc.

Generally, to graphically analyze tomographic images, a clinician scrolls through a series of image frames and manually performs various measurements on the anatomical structure of interest. In some instances, a computational algorithm is also used to calculate various anatomical measurements and display their numerical values to an image display screen. While the numerical output provides useful information, it is time consuming to evaluate and compare a large data set of tomographic images by scrolling through frames of images. The extended periods of scrutiny also lead to mental fatigue, and in turn, may lead to observer error.

In addition to evaluating vasculature, tomographic imaging may also be used to place or evaluate vascular stents. A stent is a small, tube-like structure made of a metal or polymer that is inserted into a blood vessel to hold the vessel open and keep it from occluding blood flow. A stent can also be used to reinforce an area of a vessel where the wall tissues are thin or calcification has formed. Typically, a stent is placed with a balloon catheter after the vessel has been imaged.

There are several risks associated with stent placement, however. For example, the stent can cause vascular lesions that may later embolize (dislodge and block vasculature). To avoid lesions, the stent should be placed in parallel within the vessel and the stent should uniformly contact the vessel wall during deployment. Additionally, it is critical that there is no dead space between the stent and the vessel wall because of a risk of a subsequent blockage or thrombus

because of blood pooling or clotting between the stent and the vessel wall. (A stent that has been placed with gaps between the stent and the vessel wall is said to be in "incomplete apposition.") Therefore, it is critical to verify that the stent is properly placed.

When tomographic imaging is used to evaluate a stent (or other medical device) many of the same issues arise with respect to overwhelming sets of images and fatigue related to processing the images. In addition, it can be difficult to immediately discern problematic placement of a medical device because of the visual similarity between a properly and improperly placed device when the images are displayed on a computer monitor, for example.

SUMMARY OF THE INVENTION

The invention generally provides systems and methods for helping health care providers visualize important parameters in a medical image. The user is provided with an enhanced graphical display of images defining biological lumens and/or medical devices resulting from anatomical measurements. A variety of important parameters can be emphasized through the use of visual, audio, or tactile displays or alerts. In some instances, the imaging data sets will have been obtained from optical coherence tomography or ultrasound measurements. For even greater analysis, interaction with the images will prompt the display of additional, relevant images with greater detail. Accordingly, methods of the invention will speed review of the image data sets by allowing a provider to more quickly synthesize the data and focus on areas of concern. Additionally, displaying images with relevant indicators and the use of alerts will reduce the potential for error during clinical evaluation.

The invention includes systems and methods for aiding a user in analyzing an imaging data set relating to a medical device and a biological structure defining a lumen. The system comprises a monitor to display an image, a central processing unit (CPU), and storage coupled to the CPU for storing instructions to carry out the methods of the invention. Typically, the instructions configure the CPU to analyze the imaging data set for a parameter, assign an indicator to the medical device based on the presence of the parameter, and display the indicator. In some embodiments, the indicator is a color. The parameter may relate to any of a number of conditions or concerns that could be evaluated with the information contained in the imaging data set. For example, the parameter might be diameter of a vessel, area of a vessel lumen, thickness of a vessel lumen wall, plaque burden, vessel remodeling index, tissue type, size of a thrombus, location of a thrombus, blood flow, blood pressure, fluid dynamic measurement, stent type, stent apposition, stent coverage, stent fracture, or stent placement. The medical device may be a stent, a pacemaker, a prosthetic valve, a graft, and implant, a sterilization device, a catheter, or an electrode.

The invention is applicable to imaging data sets from devices that produce two dimensional data sets from which three dimensional image compositions are derived, for example optical coherence tomography, intravascular ultrasound, co-registered optical coherence tomography and intravascular ultrasound, co-registered optical coherence tomography and angiography, co-registered intravascular ultrasound and angiography, spectroscopy, photoacoustic tomography, intravascular magnetic resonance imaging, angiography, or combinations thereof.

The invention additionally includes systems and methods to aid a user in assessing an imaging data set relating to a

lumen of a biological structure. The system comprises a monitor to display an image, a central processing unit (CPU), and storage coupled to the CPU for storing instructions to carry out the methods of the invention. Typically, the instructions configure the CPU to analyze the imaging data set for a parameter, display an image associated with the imaging data set on the monitor, provide the user with a graphical user interface (GUI) on the monitor, and activate an alert when the user interacts with the displayed image or a portion of the displayed image and the parameter is at or beyond a threshold value. The alert may be a visual alert, an audio alert, a haptic alert, a dynamic gauge indicator alert, or a combination thereof. In some embodiments the visual alert is a color-coded indicator, a pulsating indicator, a color map of the image parameter, an altered-sized image, an altered-sized parameter encoded in an image, a gauge, a callout marker, or combinations thereof. In some embodiments, the user is provided with a dynamic graphical icon based on the parameter.

In other aspects the instructions may configure the CPU to analyze the imaging data set for a plurality of values of a parameter, display on the monitor a first intraluminal image having indicators corresponding to the values of the parameter, provide the user with a graphical user interface (GUI) on the monitor, and display a value of the parameter when the user interacts with the intraluminal image. Alternatively or additionally, when the user interacts with the first intraluminal image the system may display a second intraluminal image. In an embodiment, the first intraluminal image is a 3D representation of a lumen and the second intraluminal image is a cross-sectional view of the lumen.

BRIEF DESCRIPTION OF FIGURES

FIG. 1 is a perspective view of a vessel.

FIG. 2 is a cross-sectional view of the vessel shown in FIG. 1.

FIG. 3 is a diagram of components of an optical coherence tomography (OCT) system.

FIG. 4 is a diagram of the imaging engine shown in FIG. 3.

FIG. 5 is a diagram of a light path in an OCT system of certain embodiments of the invention.

FIG. 6 is a patient interface module of an OCT system.

FIG. 7 is an illustration of the motion of parts of an imaging catheter according to certain embodiments of the invention.

FIG. 8 shows an array of A-scan lines of a three-dimensional imaging system according to certain embodiments of the invention.

FIG. 9 shows the positioning of A-scans within a vessel.

FIG. 10 illustrates a set of A-scans used to compose a B-scan according to certain embodiments of the invention.

FIG. 11 shows the set of A-scans shown in FIG. 10 within a cross section of a vessel.

FIG. 12 shows an OCT polar coordinate B-Scan with 660 A-scans.

FIG. 13 shows a scan-converted image of the B-scan in FIG. 12.

FIG. 14 is a block diagram of a system for producing images that may be processed with systems of the invention.

FIG. 15 is a block diagram for a system for indicating parameters in an imaging data set.

FIG. 16A shows block diagrams for the procedural steps in color coding a medical device in a medical image.

FIG. 16B shows block diagrams for assigning a user alert to an image property.

FIG. 16C shows block diagrams for interacting with an image to display a parameter value.

FIG. 16D shows block diagrams for interacting with an image to display a secondary image.

FIG. 17 illustrates a color-coded lumen indicating that the cross sectional area of a vessel lumen is smaller than a predetermined threshold value.

FIG. 18 illustrates a color-coded lumen indicating that the cross sectional area of a vessel lumen is larger than a predetermined threshold value.

FIG. 19 illustrates a color-coded lumen as in FIG. 17, with the color coding of the lumen showing transparency.

FIG. 20 illustrates a color-coded lumen as in FIG. 18, with the color coding of the lumen showing transparency.

FIG. 21A shows exemplary indicators that may be used to indicate values of parameters.

FIG. 21B shows exemplary indicators that may be used to indicate values of parameters.

FIG. 22 illustrates a longitudinal view of a lumen with shading based upon lumen area.

FIG. 23 illustrates a three-dimensional view of a lumen color-coded to indicate the cross sectional area.

FIG. 24 illustrates the use of a graphical user interface to interact with an image and to prompt display of a second related image.

FIG. 25 illustrates a splayed view of a stent placed within a lumen wherein the stent is color-coded to indicate apposition.

FIG. 26 illustrates a three-dimensional view of a stent placed within a lumen wherein the stent is color-coded to indicate apposition.

FIG. 27 illustrates a splayed view of a stent placed within a lumen wherein markers are used to set boundaries for an analysis of the image.

DESCRIPTION OF THE INVENTION

This invention generally relates to systems for indicating parameters in an imaging data set, for example, an imaging data set relating to a medical device or a biological lumen. Medical imaging is a general technology class in which sectional and multidimensional anatomic images are constructed from acquired data. The data can be collected from a variety of signal acquisition systems including, but not limited to, magnetic resonance imaging (MRI), radiography methods including fluoroscopy, x-ray tomography, computed axial tomography and computed tomography, nuclear medicine techniques such as scintigraphy, positron emission tomography and single photon emission computed tomography, photo acoustic imaging ultrasound devices and methods including, but not limited to, intravascular ultrasound spectroscopy (IVUS), ultrasound modulated optical tomography, ultrasound transmission tomography, other tomographic techniques such as electrical capacitance, magnetic induction, functional MRI, optical projection and thermoacoustic imaging, combinations thereof and combinations with other medical techniques that produce one-, two- and three-dimensional images. Although the exemplifications described herein are drawn to the invention as applied to OCT, at least all of these techniques are contemplated for use with the systems and methods of the present invention.

Through the use of the imaging techniques described herein, anatomical structures can be evaluated, visually optimized, or linked to at least one other sensory output when a predetermined threshold is reached, and provided to the user. Corresponding numerical measurements can be provided to the user by these methods in one-, two- or

three-dimensional image data sets. User interface graphics also may provide input for other indicators on a monitor interface, for example a color bar associated with percent changes in size, depth, height, width, etc., of an anatomical structure or dynamic graphical indicators displaying a value correlated to a lumen image parameter. The method enhances visual examination each image in image data sets, thereby reducing user error in evaluation and assessment of a clinical condition.

The methods and systems of the present invention embody various visual, audio, or tactile indicators to emphasize image parameters in medical images. Such indicators include, for example, a color-coded indicator, a pulsating indicator, a color map of the image parameter, an altered-sized lumen image, an altered-sized parameter encoded in a lumen image, a gauge, a callout marker, and combinations thereof. In certain embodiments, the pulsating indicator can be an icon, a lumen image, a lumen image parameter, a color-coded indicator, a color map of the image parameter, and any combination. In other examples, the pulsating of the pulsating indicator occurs at a frequency specific to the image parameter. In some embodiments, a heat map of image parameters may be used, such that a user may quickly assess a plurality of values of a parameter. For example a structure may be coded red to green based upon low to high, or bad to good, or high risk to low risk, to indicate a range of values. Alternatively, structures may also be coded with shading or fill designs (e.g., cross-hatching) to indicate values of parameters.

Various embodiments of visual indicators can include, for example, a dynamic graphical icon for the image parameter. The dynamic graphical icon can be a callout marker that brackets or otherwise delimits a parameter as a user scrolls through a series of images, or it can be, for example, a needle gauge that adjusts its value to any of a range of values for an image parameter that changes as a user scrolls through a set of images.

The systems and methods described herein are not limited to the display of a single parameter, however. That is, in some embodiments, multiple parameters are simultaneously displayed. Each parameter may have a corresponding visual, audio, or haptic indicator. In some embodiments, multiple parameters are indicated by multiple color schemes. In some embodiments, multiple parameters are indicated by a mix of visual, audio, and haptic indicators. In some embodiments, a user may toggle between parameters or the user will see a second image indicating a different parameter as the user interacts with the image.

Other examples of the present invention include an indicator that is activated as a user scrolls over at least one image having a predetermined parameter threshold. A sensory inducing output can include, for example, a visual indicator, an audio indicator, a haptic indicator, a gauge indicator, and combinations thereof. In certain examples, the visual sensory inducing output can include a color-coded indicator, a pulsating indicator, a color map of the image parameter, an altered-sized lumen image, an altered-sized parameter encoded in a lumen image, and combinations thereof. Alternatively, the background of the image could flash, the screen could momentarily show a negative image of the displayed image and then return, or a color image could change to a half-tone image.

The pulsating indicator may be, for example, an icon, a lumen image, a lumen image parameter, a color-coded indicator, a color map of the image parameter, or any combination thereof. An image may pulsate at a rate related

to the parameter of interest. Generally, any indicator can be set to occur once a threshold value of a parameter is reached.

Audio indicators may include, for example, a sound specific to a parameter. In certain embodiments, the audio indicator can become activated if an image parameter is present in any particular image. In other embodiments, the audio indicator can become activated when, for example, a user scrolls over a lumen image encoding a threshold value of a particular image parameter. The audio indicator may be a tone, beep, music (e.g., musical scale), horn, or a buzz.

In other examples, a sensory inducing output includes haptic indicators, for example a vibration in a system component at a physical interface between a user and the system component. The system component can include, as non-limiting examples, a computer-aided display control module, hereinafter referred to as a "computer mouse," or a touch-screen monitor that imparts a tactile signal to the user, for example a vibration, as a user scrolls over a lumen image encoding a threshold value of a particular image parameter. In related embodiments, a haptic indicator can be activated if a particular image encodes the desired parameter, or an image parameter threshold is encoded in the image.

Systems and methods of the invention have application in intravascular imaging methodologies such as intravascular ultrasound (IVUS) and optical coherence tomography (OCT) among others that produce a three-dimensional image of a lumen. A segment of a lumen **101** is shown in FIG. **1** in a 3D-view having a feature **113** of interest. FIG. **2** shows a cross-section of lumen **101** through feature **113**. In certain embodiments, intravascular imaging involves positioning an imaging device near feature **113** and collecting data representing a three-dimensional image.

Various lumens of biological structures may be imaged with the described technologies, including blood vessels, vasculature of the lymphatic and nervous systems, various structures of the gastrointestinal tract including lumen of the small intestine, large intestine, stomach, esophagus, colon, pancreatic duct, bile duct, hepatic duct, lumen of the reproductive tract including the vas deferens, vagina, uterus and fallopian tubes, structures of the urinary tract including urinary collecting ducts, renal tubules, ureter, and bladder, and structures of the head and neck and pulmonary system including sinuses, parotid, trachea, bronchi, and lungs.

The arteries of the heart are particularly useful to examine with imaging devices such as OCT. OCT imaging of the coronary arteries can determine the amount of plaque built up at any particular point in the coronary artery. The accumulation of plaque within the artery wall over decades is the setup for vulnerable plaque which, in turn, leads to heart attack and stenosis (narrowing) of the artery. OCT is useful in determining both plaque volume within the wall of the artery and/or the degree of stenosis of the artery lumen. It can be especially useful in situations in which angiographic imaging is considered unreliable, such as for the lumen of ostial lesions or where angiographic images do not visualize lumen segments adequately. Example regions include those with multiple overlapping arterial segments. It is also used to assess the effects of treatments of stenosis such as with hydraulic angioplasty expansion of the artery, with or without stents, and the results of medical therapy over time. In an exemplary embodiment, the invention provides a system for capturing a three dimensional image by OCT.

OCT is a medical imaging methodology using a specially designed catheter with a miniaturized near infrared light-emitting probe attached to the distal end of the catheter. As an optical signal acquisition and processing method, it

captures micrometer-resolution, three-dimensional images from within optical scattering media (e.g., biological tissue). Commercially available OCT systems are employed in diverse applications, including art conservation and diagnostic medicine, notably in ophthalmology where it can be used to obtain detailed images from within the retina. The detailed images of the retina allow one to identify several eye diseases and eye trauma. Recently it has also begun to be used in interventional cardiology to help diagnose coronary artery disease. OCT allows the application of interferometric technology to see from inside, for example, blood vessels, visualizing the endothelium (inner wall) of blood vessels in living individuals.

Other applications of OCT and other signal processing imaging systems for biomedical imaging include use in: dermatology in order to image subsurface structural and blood flow formation; dentistry in order to image the structure of teeth and gum line to identify and track de-mineralization and re-mineralization, tartar, caries, and periodontal disease; gastroenterology in order to image the gastrointestinal tract to detect polyps and inflammation, such as that caused by Crohn's disease and ulcerative colitis; cancer diagnostics in order to discriminate between malignant and normal tissue.

Generally, an OCT system comprises three components which are 1) an imaging catheter 2) OCT imaging hardware, 3) host application software. When utilized, the components are capable of obtaining OCT data, processing OCT data, and transmitting captured data to a host system. OCT systems and methods are generally described in Milner et al., U.S. Patent Application Publication No. 2011/0152771, Condit et al., U.S. Patent Application Publication No. 2010/0220334, Castella et al., U.S. Patent Application Publication No. 2009/0043191, Milner et al., U.S. Patent Application Publication No. 2008/0291463, and Kemp, N., U.S. Patent Application Publication No. 2008/0180683, the content of each of which is incorporated by reference in its entirety. In certain embodiments, systems and methods of the invention include processing hardware configured to interact with more than one different three dimensional imaging system so that the tissue imaging devices and methods described here in can be alternatively used with OCT, IVUS, or other hardware.

In OCT, a light source delivers a beam of light to an imaging device to image target tissue. Light sources can be broad spectrum light sources, or provide a more limited spectrum of wavelengths, e.g., near infra-red. The light sources may be pulsed or continuous wave. For example the light source may be a diode (e.g., superluminescent diode), or a diode array, a semiconductor laser, an ultrashort pulsed laser, or supercontinuum light source. Typically the light source is filtered and allows a user to select a wavelength of light to be amplified. Wavelengths commonly used in medical applications include near-infrared light, for example between about 800 nm and about 1700 nm. Methods of the invention apply to image data obtained from obtained from any OCT system, including OCT systems that operate in either the time domain or frequency (high definition) domain.

In time-domain OCT, an interference spectrum is obtained by moving a scanning optic, such as a reference mirror, longitudinally to change the reference path and match multiple optical paths due to reflections of the light within the sample. The signal giving the reflectivity is sampled over time, and light traveling at a specific distance creates interference in the detector. Moving the scanning mechanism laterally (or rotationally) across the sample produces reflectance

distributions of the sample (i.e., an imaging data set) from which two-dimensional and three-dimensional images can be produced.

In frequency domain OCT, a light source capable of emitting a range of optical frequencies passes through an interferometer, where the interferometer combines the light returned from a sample with a reference beam of light from the same source, and the intensity of the combined light is recorded as a function of optical frequency to form an interference spectrum. A Fourier transform of the interference spectrum provides the reflectance distribution along the depth within the sample.

Several methods of frequency domain OCT are described in the literature. In spectral-domain OCT (SD-OCT), also sometimes called "Spectral Radar" (*Optics Letters*, vol. 21, No. 14 (1996) 1087-1089), a grating or prism or other means is used to disperse the output of the interferometer into its optical frequency components. The intensities of these separated components are measured using an array of optical detectors, each detector receiving an optical frequency or a fractional range of optical frequencies. The set of measurements from these optical detectors forms an interference spectrum (Smith, L. M. and C. C. Dobson, *Applied Optics* vol. 28: (1989) 3339-3342), wherein the distance to a scatterer is determined by the wavelength dependent fringe spacing within the power spectrum. SD-OCT has enabled the determination of distance and scattering intensity of multiple scatters lying along the illumination axis by analyzing the exposure of an array of optical detectors so that no scanning in depth is necessary.

Alternatively, in swept-source OCT, the interference spectrum is recorded by using a source with adjustable optical frequency, with the optical frequency of the source swept through a range of optical frequencies, and recording the interfered light intensity as a function of time during the sweep. An example of swept-source OCT is described in U.S. Pat. No. 5,321,501.

Time- and frequency-domain systems can further vary based upon the optical layout of the systems: common beam path systems and differential beam path systems. A common beam path system sends all produced light through a single optical fiber to generate a reference signal and a sample signal whereas a differential beam path system splits the produced light such that a portion of the light is directed to the sample and the other portion is directed to a reference surface. Common beam path systems are described in U.S. Pat. Nos. 7,999,938; 7,995,210; and 7,787,127 and differential beam path systems are described in U.S. Pat. Nos. 7,783,337; 6,134,003; and 6,421,164, the contents of each of which are incorporated by reference herein in their entireties.

In certain embodiments, the invention provides a differential beam path OCT system with intravascular imaging capability as illustrated in FIG. 3. For intravascular imaging, a light beam is delivered to the vessel lumen via a fiber-optic based imaging catheter 826. The imaging catheter is connected through hardware to software on a host workstation. The hardware includes imaging engine 859 and a handheld patient interface module (PIM) 839 that includes user controls. The proximal end of imaging catheter 826 is connected to PIM 839, which is connected to imaging engine 859 as shown in FIG. 3.

An embodiment of imaging engine 859 is shown in FIG. 4. Imaging engine 859 (i.e., the bedside unit) houses power distribution board 849, light source 827, interferometer 831, and variable delay line 835 as well as a data acquisition (DAQ) board 855 and optical controller board (OCB) 851.

PIM cable **841** connects imaging engine **859** to PIM **839** and engine cable **845** connects imaging engine **859** to the host workstation (not shown).

FIG. **5** shows an exemplary light path in a differential beam path system which may be used in an OCT system suitable for use with the invention. Light for producing the measurements originates within light source **827**. This light is split between main OCT interferometer **905** and auxiliary interferometer **911**. In some embodiments, the auxiliary interferometer is referred to as a “clock” interferometer. Light directed to main OCT interferometer **905** is further split by splitter **917** and recombined by splitter **919** with an asymmetric split ratio. The majority of the light from splitter **917** is guided into sample path **913** while the remainder goes into reference path **915**. Sample path **917** includes optical fibers running through PIM **839** and imaging catheter core **826** and terminating at the distal end of the imaging catheter, where the sample is measured.

The reflected light is transmitted along sample path **913** to be recombined with the light from reference path **915** at splitter **919**. A variable delay line (VDL) **925** on the reference path uses an adjustable fiber coil to match the length of reference path **915** to the length of sample path **913**. The reference path length is adjusted by a stepper motor translating a mirror on a translation stage under the control of firmware or software.

The combined light from splitter **919** is split into orthogonal polarization states, resulting in RF-band polarization-diverse temporal interference fringe signals. The interference fringe signals are converted to photocurrents using PIN photodiodes **929a**, and **929b**, on optical controller board (OCB) **851**. The interfering, polarization splitting, and detection steps are done by a polarization diversity module (PDM) (not shown) on OCB **851**. Signal from OCB **851** is sent to DAQ **855**, shown in FIG. **4**. DAQ **855** includes a digital signal processing (DSP) microprocessor and a field programmable gate array (FPGA) to digitize signals and communicate with the host workstation and PIM **839**. The FPGA converts raw optical interference signals into meaningful reflectivity measurements. DAQ **855** also compresses data as necessary to reduce image transfer bandwidth, e.g., to 1 Gbps, e.g., by compressing frames with a glossy compression JPEG encoder.

Typical intravascular OCT involves introducing the imaging catheter into a patient’s target vessel using standard interventional techniques and tools such as a guide wire, guide catheter, and angiography system. The imaging catheter may be integrated with IVUS by an OCT-IVUS system for concurrent imaging, as described in, for example, Castella et al. U.S. Patent Application Publication No. 2009/0043191 and Dick et al. U.S. Patent Application Publication No. 2009/0018393, both of which are incorporated by reference in their entireties.

The details of PIM **839** which control the sample measurements are shown in FIG. **6**. Rotation of imaging catheter core **826** is driven by spin motor **861** while proximal translation of imaging catheter core **826** is driven by pull-back motor **665**. The combination of rotation and translation along axis **117** produces a spiral motion for image illumination and collection, as described by FIG. **7**. In many embodiments, blood within the lumen to be imaged is temporarily flushed with a clear solution prior to imaging. The reflected light is received by an inner core of imaging catheter core **826** and optically interacts with light from the reference path, giving rise to an array of reflectance distribution vectors (A-scans) as illustrated schematically in FIG. **8**.

FIG. **9** shows an exemplary schematic of the positioning of A-scans within a lumen, e.g., a vessel. The separation between the A-scan lines has been exaggerated for simplicity. At each place where an A-scan, e.g., $A_{11}, A_{12}, \dots, A_N$, intersects a surface of the lumen (e.g., a vessel wall) sample light illuminates the sample, is reflected, and a portion of the reflected light is captured. The captured reflected light then interacts with reference light and then is detected, as described above. Differences in reflections detected along each A-scan line are associated with features within the imaged lumen. Data is collected from A-scans $A_{11}, A_{12}, \dots, A_N$ and stored in a tangible, non-transitory memory. Typically, rotational systems consist of an imaging core which rotates and pulls back (or pushes forward) while recording an image video loop. This motion results in a three dimensional dataset of two dimensional image frames, where each frame provides a 360° slice of the vessel at different longitudinal locations.

A collective set of A-scans generally corresponding to one rotation of catheter imaging core **826** around axis **117** is used to produce a B-scan. FIG. **10** illustrates a set of A-scans $A_{11}, A_{12}, \dots, A_{18}$ used to compose a B-scan according to certain embodiments of the invention. These A-scan lines are shown as would be seen looking down axis **117** (i.e., longitudinal distance between them is not shown). While eight A-scan lines are illustrated in FIG. **10**, typical OCT applications can include between 300 and 1,000 A-scan lines per B-scan (e.g., about 660).

The data of all the A-scan lines together can be used to create three-dimensional images of the tissue. First, the A-scans can be used to create a B-scan, which in one embodiment is a cross-sectional image of the lumen sometimes referred to as a tomographic view. For example, FIG. **12** shows a B-scan comprising a set of 660 A-scans collected as described in FIGS. **7-11**, i.e., within a cross section of a vessel. Alternatively, the set of A-scans may be transformed by a rotational imaging modality to form a B-scan corresponding to a cross-sectional image, as shown in FIG. **13**. The rotational measurement of the catheter in a counter-clockwise fashion is indicated by the circular white arrow in FIG. **13**. This sampling motion corresponds to the motion of the white arrow from 0 to 660 in FIG. **12**. It should also be noted in FIGS. **12-13** that the imaging catheter was closer to the upper vessel wall, leading to the concentric circles at the 12 o’clock position in FIG. **13** and a lack of symmetry FIG. **12**. After B-scans are produced as a function of position along axis **117**, the B-scans can be processed to produce longitudinal and three-dimensional views of the lumen, such as shown in FIGS. **22** and **23**.

In order to construct the images, the collected reflectivity measurements are processed with various computer or processor-based systems which compile data from measurements into a pictorial format. For example, the system described in FIG. **14** may be used to construct intraluminal images from OCT probe measurements, and optionally display the images to a user of the OCT system. In some embodiments, a user interacts with a visual interface to view images from the imaging system. Input from a user (e.g., parameters or a selection) are received by a processor in an electronic device. The selection can be rendered into a visible display. An exemplary system including an electronic device is illustrated in FIG. **14**. As shown in FIG. **14**, imaging engine **859** communicates with host workstation **2433** as well as optionally server **2413** over network **2409**. In some embodiments, an operator uses computer **2449** or terminal **2467** to control system **2400** or to receive images. An image may be displayed using an I/O **2454**, **2437**, or

2471, which may include a monitor. An I/O may include a keyboard, mouse or touchscreen to communicate with any of processor 2421, 2459, 2441, or 2475, for example, to cause data to be stored in any tangible, nontransitory memory 2463, 2445, 2479, or 2429. Server 2413 generally includes an interface module 2425 to effectuate communication over network 2409 or write data to data file 2417.

System 2400 may be used to execute instructions to display images in an interactive format, e.g., with indicators, as described above. Alternatively, an imaging data set may be assessed, analyzed, and transformed with a system comprising CPU 1510, storage 1520, and monitor 1530. Storage 1520 may contain instructions for carrying out methods of the invention, e.g., to configure CPU 1510 to analyze the imaging data set for a parameter, assign an indicator to the medical device based on the presence of the parameter, and display the indicator on monitor 1530. For example CPU 1510 may direct monitor 1530 to display a longitudinal image of a lumen with a color-coded stent. In some embodiments, a system of the invention will additionally comprise graphical user interface (GUI) 1540, which allows a user to interact with the images. In some embodiments, CPU 1510, storage 1520, and monitor 1530 may be encompassed within system 2400.

The systems and methods of use described herein can be performed using any type of computing device, such as a computer, that includes a processor or any combination of computing devices where each device performs at least part of the process or method. In some embodiments, systems and methods described herein may be performed with a handheld device, e.g., a smart tablet, or a smart phone, or a specialty device produced for the system.

In some embodiments, a device of the invention includes an OCT imaging system and obtains a three-dimensional data set through the operation of OCT imaging hardware. In some embodiments, a device of the invention is a computer device such as a laptop, desktop, or tablet computer, and obtains a three-dimensional data set by retrieving it from a tangible storage medium, such as a disk drive on a server using a network or as an email attachment.

Methods of the invention can be performed using software, hardware, firmware, hardwiring, or combinations of any of these. Features implementing functions can also be physically located at various positions, including being distributed such that portions of functions are implemented at different physical locations (e.g., imaging apparatus in one room and host workstation in another, or in separate buildings, for example, with wireless or wired connections).

Processors suitable for the execution of computer program include, by way of example, both general and special purpose microprocessors, and any one or more processor of any kind of digital computer. Generally, a processor will receive instructions and data from a read-only memory or a random access memory or both. The essential elements of computer are a processor for executing instructions and one or more memory devices for storing instructions and data. Generally, a computer will also include, or be operatively coupled to receive data from or transfer data to, or both, one or more mass storage devices for storing data, e.g., magnetic, magneto-optical disks, or optical disks. Information carriers suitable for embodying computer program instructions and data include all forms of non-volatile memory, including by way of example semiconductor memory devices, (e.g., EPROM, EEPROM, solid state drive (SSD), and flash memory devices); magnetic disks, (e.g., internal hard disks or removable disks); magneto-optical disks; and optical disks (e.g., CD and DVD disks). The processor and

the memory can be supplemented by, or incorporated in, special purpose logic circuitry.

To provide for interaction with a user, the subject matter described herein can be implemented on a computer having an I/O device, e.g., a CRT, LCD, LED, or projection device for displaying information to the user and an input or output device such as a keyboard and a pointing device, (e.g., a mouse or a trackball), by which the user can provide input to the computer. Other kinds of devices can be used to provide for interaction with a user as well. For example, feedback provided to the user can be any form of sensory feedback, (e.g., visual feedback, auditory feedback, or tactile feedback), and input from the user can be received in any form, including acoustic, speech, or tactile input.

The subject matter described herein can be implemented in a computing system that includes a back-end component (e.g., a data server), a middleware component (e.g., an application server), or a front-end component (e.g., a client computer having a graphical user interface or a web browser through which a user can interact with an implementation of the subject matter described herein), or any combination of such back-end, middleware, and front-end components. The components of the system can be interconnected through network by any form or medium of digital data communication, e.g., a communication network. Examples of communication networks include cell network (e.g., 3G or 4G), a local area network (LAN), and a wide area network (WAN), e.g., the Internet.

The subject matter described herein can be implemented as one or more computer program products, such as one or more computer programs tangibly embodied in an information carrier (e.g., in a non-transitory computer-readable medium) for execution by, or to control the operation of, data processing apparatus (e.g., a programmable processor, a computer, or multiple computers). A computer program (also known as a program, software, software application, app, macro, or code) can be written in any form of programming language, including compiled or interpreted languages (e.g., C, C++, Perl), and it can be deployed in any form, including as a stand-alone program or as a module, component, subroutine, or other unit suitable for use in a computing environment. Systems and methods of the invention can include instructions written in any suitable programming language known in the art, including, without limitation, C, C++, Perl, Java, ActiveX, HTML5, Visual Basic, or JavaScript.

A computer program does not necessarily correspond to a file. A program can be stored in a file or a portion of file that holds other programs or data, in a single file dedicated to the program in question, or in multiple coordinated files (e.g., files that store one or more modules, sub-programs, or portions of code). A computer program can be deployed to be executed on one computer or on multiple computers at one site or distributed across multiple sites and interconnected by a communication network.

A file can be a digital file, for example, stored on a hard drive, SSD, CD, or other tangible, non-transitory medium. A file can be sent from one device to another over a network (e.g., as packets being sent from a server to a client, for example, through a Network Interface Card, modem, wireless card, or similar).

Writing a file according to the invention involves transforming a tangible, non-transitory computer-readable medium, for example, by adding, removing, or rearranging particles (e.g., with a net charge or dipole moment into patterns of magnetization by read/write heads), the patterns then representing new collocations of information about

objective physical phenomena desired by, and useful to, the user. In some embodiments, writing involves a physical transformation of material in tangible, non-transitory computer readable media (e.g., with certain optical properties so that optical read/write devices can then read the new and useful collocation of information, e.g., burning a CD-ROM). In some embodiments, writing a file includes transforming a physical flash memory apparatus such as NAND flash memory device and storing information by transforming physical elements in an array of memory cells made from floating-gate transistors. Methods of writing a file are well-known in the art and, for example, can be invoked manually or automatically by a program or by a save command from software or a write command from a programming language.

Suitable computing devices typically include mass memory, at least one graphical user interface, at least one display device, and typically include communication between devices. The mass memory illustrates a type of computer-readable media, namely computer storage media. Computer storage media may include volatile, nonvolatile, removable, and non-removable media implemented in any method or technology for storage of information, such as computer readable instructions, data structures, program modules, or other data. Examples of computer storage media include RAM, ROM, EEPROM, flash memory, or other memory technology, CD-ROM, digital versatile disks (DVD) or other optical storage, magnetic cassettes, magnetic tape, magnetic disk storage or other magnetic storage devices, Radiofrequency Identification tags or chips, or any other medium which can be used to store the desired information and which can be accessed by a computing device.

Exemplary step-by-step methods are described schematically in FIGS. 16A-D. It will be understood that each block of FIGS. 16A-D, as well as any portion of the systems and methods disclosed herein, can be implemented by computer program instructions. These program instructions may be provided to a processor to produce a machine, such that the instructions, which execute on the processor, create means for implementing the actions specified in the FIGS. 16A-D or described for the systems and methods disclosed herein. The computer program instructions may be executed by a processor to cause a series of operational steps to be performed by the processor to produce a computer implemented process. The computer program instructions may also cause at least some of the operational steps to be performed in parallel. Moreover, some of the steps may also be performed across more than one processor, such as might arise in a multi-processor computer system. In addition, one or more processes may also be performed concurrently with other processes or even in a different sequence than illustrated without departing from the scope or spirit of the invention.

A basic function of a system of the invention is described in FIG. 16A in which an image data set is received, one or more parameters is specified and analyzed, an indicator is selected, and the indicator is displayed. In some instances, e.g., as shown in FIG. 16B a threshold value of the parameter will be defined by the user, however in other instances this is not necessary. Additionally, as shown in FIG. 16B the user may be provided with a GUI to set a threshold alert and interact with the images, thereby triggering an alert when the threshold value is exceeded. In alternative embodiments, e.g., as shown in FIGS. 16C and 16D, a user may also cause parameter values to be displayed or cause additional images to be displayed by interacting with the GUI.

Threshold analysis can be completed using algorithms known in the field of image analysis. For example, a value

input by a user may be converted into a threshold level which will be applied to one or more pixels of a B-scan image (e.g., FIG. 12). When the level of the measured pixels is greater than the threshold value, the corresponding pixels in the scan converted image (e.g., FIG. 13) will be displayed in green. When the level of the pixels is less than the threshold value, the corresponding pixels in the scan converted image (e.g., FIG. 13) will be displayed in red. The method can be extended to produce multicolored displays by using threshold ranges, i.e., multiband thresholding. In some instances, the threshold levels maybe preset, or the user may select from a list or preset levels, for example, by selecting levels from a pull-down menu in the GUI.

In other instances, automatic thresholding may be used, wherein an image data set is analyzed to determine a distribution of levels of pixels for a location in the images (e.g., the OCT B-scans), the median of the distribution is set as the threshold, and then pixels of images which fall above and below the threshold may be colored appropriately. In some embodiments, only the pixels that fall outside of a statistical range will be color coded.

It is also intended that a user could define a threshold which will correspond to an aspect of a scan converted image (e.g., FIG. 13) or a longitudinal or 3D view of a lumen. For example, a user could define a threshold for a minimum lumen area. The system would automatically determine a lumen area for each segment of the lumen based upon an analysis of the B-Scan or the scan converted image, and then compare the threshold for a minimum lumen area to the determined lumen area for each segment. Segments having a lumen area less than the minimum lumen area could be color-coded red, for example.

Systems and methods of the invention provide images of lumen where parameters are displayed as indicators to assist a user in identifying key features which may be indicative of a disease or disorder. For example, a user may set a threshold value for a diameter of a lumen to be imaged with OCT. When the user views the images of a lumen, an indicator, e.g., a color code, is also displayed atop the image as shown in FIGS. 17 and 18. In the instance of a lumen having a lumen area smaller than the threshold (FIG. 17), the perimeter of the lumen may be colored red or a red dot may be displayed in the center of the image. In the instance of a lumen having a lumen area greater than the threshold (FIG. 18), the perimeter of the lumen may be colored green or a green dot may be displayed in the center of the image. Various other indicators could be used in the image, for example a prominent "X" for the lumen having a lumen area less than the threshold, and a prominent check mark for the lumen having a lumen area greater than the threshold. Combinations of colors and marks would also be suitable. To the extent that the displayed indicators obstructed the view of key image features, the indicators can be made partially transparent, e.g., as shown in FIGS. 19 and 20, where the images of FIGS. 17 and 18 (respectively) are marked with semi-transparent indicators. In other embodiments, the user may be able to toggle the indicators on or off, for example by "right-clicking" on the image and selecting to turn off the indicators. While not shown in the FIGS., it is envisioned that, in some embodiments, a user can call up specific values of a parameter, e.g., a diameter of a lumen, by interacting with the image. Alternatively, interacting with the image may trigger a visual, audio, or haptic alert. In some embodiments, interacting with the image may prompt display of values of a parameter in another visual format, for

example as a gauge, such as the gauge displayed in FIG. 21A. Combinations of the above listed indicators and alerts are also possible.

In other embodiments, it will be advantageous to display measurements of a lumen in a longitudinal format, e.g., as shown in FIG. 22. As shown in FIG. 22, a number of B-scans are laid end-to-end, and a cut away is produced as if looking down into the lumen. Like the cross-sectional views of FIGS. 17-20, the perimeter of the longitudinal image can be color coded to indicate values of a parameter, e.g., with respect to a threshold value or with respect to each other. In some embodiments, the volume of the cut away can be filled with color or other symbols to indicate areas of concern.

As shown in FIG. 22, sections of the lumen in which the diameter is smaller than a threshold can be shaded with one color, e.g., red, and sections of the lumen in which the diameter is larger than a threshold can be shaded with another color e.g., green. Alternatively, the diameters can be indicated with shaded regions. In FIG. 22, a constricted region is indicated with a darker box while an unconstricted region is indicated with a lighter box. In other embodiments (not shown) a longitudinal view of the lumen may be displayed and a user can call up specific values of a parameter, e.g., a diameter of a lumen, by interacting with the image. Alternatively, interacting with the image may trigger a visual, audio, or haptic alert. For example, the user could drag a mouse pointer along the length of the longitudinal image and receive a haptic alert when the pointer is in a region of occlusion.

In other embodiments, it will be advantageous to display measurements of a lumen in a three-dimensional format, e.g., as shown in FIG. 23. As shown in FIG. 23, a number of B-scans are laid end-to-end, and a three-dimensional view of the lumen is produced. The three-dimensional view may be color-coded to indicate values of a parameter, e.g., with respect to a threshold value or with respect to each other. As shown in FIG. 23, sections of the lumen in which the diameter is smaller than a threshold can be shaded with one color, e.g., red, and sections of the lumen in which the diameter is larger than a threshold can be shaded with another color, e.g., green. Intermediate regions may be shaded with a third color, e.g., yellow. The image may be scaled with hundreds of colors spanning from red to green. In other embodiments (not shown) a three-dimensional view of the lumen may be displayed and a user can call up specific values of a parameter, e.g., a diameter of a lumen, by interacting with the image. Alternatively, interacting with the image may trigger a visual, audio, or haptic alert. For example the user could drag a mouse pointer along the length of the three-dimensional image and receive a haptic alert when the pointer is in a region of occlusion. In other embodiments, a user can click on a region of interest and bring up an alternative image, e.g., a cross sectional image, as shown in FIG. 24.

In certain embodiments a user can employ an indicator such as navigation line, a cursor, a callout marker or the like to identify an image plane in an image being viewed. For example, a three-dimensional image of a vessel can be constructed from a set of two-dimensional image frames. A user can scroll over the three-dimensional image with an indicator to identify a particular image frame corresponding to the location of the indicator on the image, as shown in FIG. 24. The particular image frame can be selected and displayed in a two-dimensional format. In certain embodiments, as a user scrolls an indicator over or through a three-dimensional image with one or more image frame

having a diagnostic property at a predefined threshold, the user will be alerted by the computer as described herein.

Using the systems and methods of the invention it is also possible to analyze and display images of medical devices with indicators relating to a parameter. As shown in FIG. 25, a splayed B-scan of a stent within a lumen can be displayed with values of apposition indicated with various colors. (In a splayed B-scan the luminal walls of a three-dimensional construct, i.e., FIG. 23, are unrolled into a two dimensional sheet.) In FIG. 25, the stent is visible as zigzag pattern across the image. Portions of the stent that display incomplete apposition ("malapposed") are shown in a dark color, while portions of the stent that are properly apposed are shown in a lighter color. In alternative embodiments, a user could interact with the image of the stent and trigger an alert, for example, when a portion of the stent displayed incomplete apposition. In other embodiments, a user could call up specific values of a parameter, e.g., apposition of the stent, by interacting with the image. In another embodiment, a user may cause a stent apposition gauge to be displayed, such as shown in FIG. 21B.

While other methods are known, systems of the invention may use edge detection algorithms to determine the boundaries of the stent and the corresponding overlap (or lack thereof) with the lumen wall. Edges of the stent may be detectable in the A-scans as pronounced changes in reflectivity, i.e., a reflectivity change of more than 10%, more than 30%, more than 50%, or more than 100%, within less than 5 mm, less than 3 mm, less than 2 mm, or less than 1 mm radial distance. A front and back radial edge of the stent can be found by determining the location of two edges in the A-scan. Alternatively, stents may be located in B-scans by determining regions of pronounced change in pixel levels, corresponding to the change in reflectivity of the A-scan discussed above.

A value for the apposition of a stent may be determined by combining stent edge detection with methods for identifying lumen borders, i.e., lumen walls. The lumen border can be automatically or semi-automatically detected in an image using any method known in the art, such as the techniques disclosed in U.S. Pat. No. 7,978,916, S. Tanimoto, G. Rodriguez-Granillo, P. Barlis, S. deWinter, N. Bruining, R. Hamers, M. Knappen, S. Verheye, P. W. Seruys, and E. Regar, "A novel approach for quantitative analysis of intracoronary optical coherence tomography: High inter-observer agreement with computer-assisted contour detection," *Cathet. Cardiovasc. Intervent.* 72, 228-235 (2008); K. Sihan, C. Botka, F. Post, S. deWinter, E. Regar, R. Hamers, and N. Bruining, "A novel approach to quantitative analysis of intraluminal optical coherence tomography imaging," *Comput. Cardiol.* 1089-1092 (2008); J. Canny, "A computational approach to edge detection," *IEEE Trans. Pattern Anal. Mach. Intell.* 8, 679-698 (1986), all incorporated herein by reference in their entireties.

In one embodiment, a value for the apposition can be determined by subtracting the radial distance of the front radial edge of the lumen border from the back radial edge of the stent. A positive value indicates a gap or a malapposed stent. A zero value or negative value would indicate that there was no gap, or that tissue had partially covered the stent. In some embodiments, the stent would be color coded to indicate that a portion of the stent was not in contact with the lumen border. In some embodiments, a scan converted image corresponding to a segment of the lumen with a malapposed stent will be color coded, or will be identified with an alert to facilitate identification by a user.

In an alternative embodiment, as shown in FIG. 26, the stent and the lumen can be shown simultaneously in a three-dimensional view. Portions of the stent that display incomplete apposition are shown in a dark color and portions of the stent that are properly apposed are shown in a lighter color.

In other embodiments, the user may interact with a portion of an image to set a range for identification of a parameter. For example, as shown in FIG. 27, a user may set the limits of a luminal image to be processed for a parameter, e.g., stent apposition, and the system of the invention will overlay indicators based on the parameter only in the region of interest.

Systems and methods of the invention include image-processing techniques that provide automatic detection of objects, such as stents, within intraluminal images. Typically, the OCT intraluminal image is an intravascular image taken within a lumen of a blood vessel, but the detection methods described herein can be used to detect objects within other biological lumens, such as the intestine. Although the following description is directed towards detecting objects in OCT images, one skilled in the art would readily recognize that methods and systems of intention can be utilized to detect objects in any intraluminal images obtained from any other imaging technique, such as intravascular ultrasound imaging (IVUS) and combined OCT-IVUS.

INCORPORATION BY REFERENCE

References and citations to other documents, such as patents, patent applications, patent publications, journals, books, papers, web contents, have been made throughout this disclosure. All such documents are hereby incorporated herein by reference in their entirety for all purposes.

Equivalents

The invention may be embodied in other specific forms without departing from the spirit or essential characteristics thereof. The foregoing embodiments are therefore to be considered in all respects illustrative rather than limiting on the invention described herein. Scope of the invention is thus indicated by the appended claims rather than by the foregoing description, and all changes which come within the meaning and range of equivalency of the claims are therefore intended to be embraced therein.

What is claimed is:

1. A system for aiding a user in analyzing an imaging data set, the system comprising:
 an imaging catheter configured to obtain the imaging data set while the imaging catheter is positioned at a plurality of locations within a lumen of a biological structure, wherein the obtained imaging data set is representative of the lumen of the biological structure and comprises a plurality of two-dimensional intraluminal images obtained at the plurality of locations;
 a monitor to display an image associated with the imaging data set;
 a central processing unit (CPU); and
 storage coupled to the CPU for storing instructions that configure the CPU to:
 receive the imaging data set from the imaging catheter;
 derive values of a lumen area using the plurality of intraluminal images obtained at the plurality of locations within the lumen;

generate, using the plurality of intraluminal images, a two-dimensional cutaway image including a longitudinal outline of the biological structure, wherein the cutaway image comprises a plurality of longitudinal locations, and wherein each longitudinal location of the cutaway image corresponds to an intraluminal image of the plurality of intraluminal images;
 assign, for each of the plurality of longitudinal locations in the cutaway image, an indicator to pixels of the biological structure based on a comparison of the values of the lumen area with a threshold value, wherein the indicator comprises different graphical representations when the value of the lumen area is greater than the threshold value or when the value of the lumen area is less than the threshold value; and
 display, on the monitor, the cutaway image and a corresponding graphical representation overlaid on the cutaway image at each of the plurality of longitudinal locations.

2. The system of claim 1, wherein the indicator comprises a plurality of colors.

3. The system of claim 1, wherein the imaging data set is obtained using at least one of optical coherence tomography, intravascular ultrasound, co-registered optical coherence tomography and intravascular ultrasound, co-registered optical coherence tomography and angioscopy, co-registered intravascular ultrasound and angioscopy, spectroscopy, photoacoustic tomography, intravascular magnetic resonance imaging, angioscopy, or combinations thereof.

4. The system of claim 1, wherein the instructions further configure the CPU to assign a second indicator to pixels of the lumen based on a selection of a parameter, a determination of a distribution of values of the selected parameter, a determination of a statistical range associated with the selected parameter, and a comparison of the values of the selected parameter to the statistical range, wherein the parameter is selected from a group consisting of a diameter of a vessel, a vessel remodeling index, a blood flow velocity, a blood pressure, fluid dynamic measurement data, and combinations thereof.

5. The system of claim 1, wherein the cutaway image additionally shows an image of a medical device disposed within the lumen.

6. The system of claim 1, wherein the cutaway image further comprises a dynamic graphical icon configured to modify the image displayed.

7. The system of claim 1, wherein the cutaway image is generated by arranging a plurality of B-scans laid end-to-end.

8. The system of claim 7, wherein the graphical representation comprises outlining a perimeter of the cutaway image, wherein the outline is color coded to indicate values of the lumen area.

9. A system for aiding a user in assessing an imaging data set, the system comprising:

an imaging catheter configured to obtain the imaging data set while the imaging catheter is positioned at a plurality of locations within a lumen of a biological structure, wherein the obtained imaging data set is representative of the lumen of the biological structure and comprises a plurality of two-dimensional intraluminal images obtained at the plurality of locations;
 a monitor to display an image associated with the imaging data set;
 a central processing unit (CPU); and
 storage coupled to the CPU for storing instructions that configure the CPU to:

receive the imaging data set from the imaging catheter; perform a first analysis of the imaging data set to at least select a parameter associated with the lumen, wherein the parameter is at least one of a diameter of the lumen, a remodeling index of the lumen, a blood flow velocity in the lumen, a blood pressure in the lumen, and fluid dynamic measurement data of the lumen;

perform a second analysis of the imaging data set to derive parameter values based on the selected parameter and using the plurality of two-dimensional intraluminal images, wherein the parameter values are associated with the plurality of locations within the lumen;

generate, using the plurality of intraluminal images, a two-dimensional cutaway image including a longitudinal outline of the biological structure, wherein the cutaway image comprises a plurality of longitudinal locations, and wherein each longitudinal location of the cutaway image corresponds to an intraluminal image of the plurality of intraluminal images; display the cutaway image on the monitor;

provide the user with a graphical user interface (GUI) on the monitor; and

activate, for each of the plurality of longitudinal locations in the cutaway image, an alert when the user interacts with a longitudinal location on the cutaway image that corresponds to a location at which imaging data of the imaging data set was obtained, wherein the alert includes pixels of the lumen based on a comparison of the values of the selected parameter within the lumen with a threshold value, wherein the alert comprises different graphical representations when the parameter value is greater than the threshold value or when the parameter value is less than the threshold value.

10. The system of claim 9, wherein the imaging data set is obtained with a technique selected from a group comprising optical coherence tomography, intravascular ultrasound, co-registered optical coherence tomography and intravascular ultrasound, co-registered optical coherence tomography and angiography, co-registered intravascular ultrasound and angiography, spectroscopy, photoacoustic tomography, intravascular magnetic resonance imaging, angiography, and combinations thereof.

11. The system of claim 9, wherein a stent is disposed within the lumen, and wherein the instructions further configure the CPU to activate a second alert when the user interacts with the cutaway image or a portion of the cutaway image that include pixels having values of a second parameter falling outside a statistical range associated with the second parameter, wherein the statistical range associated with the second parameter is determined based on a distribution of values of the second parameter, wherein the distribution is determined based on values of the second parameter, wherein the parameter is selected from a group comprising an area of the lumen, a thickness of a lumen wall, a plaque buildup in the lumen, a size of a thrombus in the lumen, a location of a thrombus in the lumen, a stent apposition in the lumen, a stent coverage of the lumen, a stent fracture amount, a stent placement location within the lumen, and combinations thereof.

12. The system of claim 9, wherein the instructions further comprise:

displaying a dynamic graphical icon based on the parameter.

13. The system of claim 9, wherein the alert is selected from a group comprising a visual alert, an audio alert, a haptic alert, a dynamic gauge indicator alert, and combinations thereof.

14. The system of claim 13, wherein, when the alert activated is a visual alert, the visual alert is selected from a group comprising a color-coded indicator, a pulsating indicator, a color map of the selected parameter, an altered-sized lumen image, an altered-sized parameter encoded in a lumen image, a gauge, a callout marker, and combinations thereof.

15. The system of claim 13, wherein the system additionally comprises a pointing device for interacting with the monitor, and, when the alert activated is a haptic alert, the haptic alert comprises a vibration in the pointing device.

16. The system of claim 9, wherein the user interacts with the cutaway image or a portion of the cutaway image by moving an indicator along a length of the displayed image or a length of the portion of the displayed image.

17. A system for aiding a user in assessing an imaging data set, the system comprising:

an imaging catheter configured to obtain the imaging data set while being positioned within a vessel of a biological structure, wherein the imaging catheter is further configured to translate in the vessel while obtaining the imaging data set representative of the vessel of the biological structure at a plurality of locations, and wherein the imaging data set comprises a plurality of two-dimensional intraluminal images obtained at a plurality of locations;

a monitor to display an image associated with the imaging data set;

a central processing unit (CPU); and

storage coupled to the CPU for storing instructions that configure the CPU to:

receive the imaging data set from the imaging catheter; perform a first analysis of the imaging data set obtained by the imaging catheter to derive a plurality of parameter values based on a selected parameter and associated with a plurality of locations within the vessel, wherein the parameter comprises a lumen area, and wherein the plurality of parameter values are derived using the plurality of two-dimensional intraluminal images;

perform a second analysis of the plurality of parameter values of the selected parameter within the vessel to automatically determine a threshold value associated with the selected parameter;

generate, using the plurality of intraluminal images, a two-dimensional cutaway image including a longitudinal outline of the biological structure, wherein the cutaway image comprises a plurality of longitudinal locations, and wherein each longitudinal location of the cutaway image corresponds to an intraluminal image of the plurality of intraluminal images; display, on the monitor, the cutaway image and indicators, for each of the plurality of longitudinal locations, corresponding to one or more of the parameter values of the selected parameter based, at least in part, on a comparison of the parameter values with the threshold value, wherein the indicator comprises different graphical representations when the parameter value is greater than the threshold value or when the parameter value is less than the threshold value;

provide the user with a graphical user interface (GUI) on the monitor; and

display a value of the parameter when the user interacts with the cutaway image of the vessel.

21

18. The system of claim 17, wherein the instructions additionally configure the CPU to display a second intraluminal image when the user interacts with the cutaway image.

19. The system of claim 18, wherein the second intraluminal image is a cross-sectional view of the vessel.

20. A system for aiding a user in assessing an imaging data set, the system comprising:

an imaging catheter configured to obtain the imaging data set while being positioned within a lumen of a biological structure, wherein the imaging catheter is further configured to translate in the lumen while obtaining the imaging data set representative of the lumen of the biological structure at a plurality of locations, and wherein the imaging data set comprises a plurality of two-dimensional intraluminal images obtained at a plurality of locations;

a monitor to display an image associated with the imaging data set;

a central processing unit (CPU); and

storage coupled to the CPU for storing instructions that configure the CPU to:

receive the imaging data set from the imaging catheter;

perform a first analysis of the imaging data set to derive a plurality of parameter values based on a selected parameter and associated with a plurality of locations within the lumen, wherein the parameter is selected from a group comprising a diameter of the lumen, a lumen remodeling index, a blood flow velocity in the lumen, a blood pressure in the lumen, and fluid dynamic measurement data of the lumen, and wherein the plurality of parameter values are derived using the plurality of two-dimensional intraluminal images;

perform a second analysis of the plurality of parameter values of the selected parameter associated with the plurality of locations within the lumen to automatically determine a threshold value associated with the selected parameter;

generate, using the plurality of intraluminal images, a two-dimensional cutaway image including a longitudinal outline of the biological structure, wherein the cutaway image comprises a plurality of longitudinal locations, and wherein each longitudinal location of the cutaway image corresponds to an intraluminal image of the plurality of intraluminal images;

display, on the monitor, the cutaway image and indicators, for each of the plurality of longitudinal locations, corresponding to one or more of the parameter values of the selected parameter based, at least in part, on a comparison of the parameter values with the threshold value, wherein the indicator comprises different graphical representations when the parameter value is greater than the threshold value or when the parameter value is less than the threshold value;

provide the user with a graphical user interface (GUI) on the monitor; and

display a second intraluminal image when the user interacts with the cutaway image.

21. The system of claim 20, wherein the second intraluminal image is a cross-sectional view of the lumen.

22. The system of claim 20, further comprising superimposing an image of a medical device configured to be disposed within the lumen on the cutaway image or the second intraluminal image.

* * * * *

专利名称(译)	用于指示成像数据集中的参数的系统及其使用方法		
公开(公告)号	US10568586	公开(公告)日	2020-02-25
申请号	US14/044987	申请日	2013-10-03
[标]申请(专利权)人(译)	火山公司		
申请(专利权)人(译)	火山CORPORATION		
当前申请(专利权)人(译)	火山CORPORATION		
[标]发明人	BEGIN ELIZABETH BURNETT JOSEPH KEMP NATHANIEL J NAIR ANUJA GLYNN TIMOTHY K SPROUL JASON		
发明人	BEGIN, ELIZABETH BURNETT, JOSEPH KEMP, NATHANIEL J. NAIR, ANUJA GLYNN, TIMOTHY K. SPROUL, JASON		
IPC分类号	A61B5/00 A61B8/00 A61B5/06 A61F2/82 A61B5/021 A61B5/02 A61B6/12 A61B6/00 A61B8/08 A61B8/12 G01R33/28 A61B5/026 G01R33/48		
CPC分类号	A61B5/066 A61F2/82 G01R33/285 A61B5/746 A61B8/465 A61B5/0035 A61B5/02007 A61B6/12 A61B5/7475 A61B8/5223 A61B8/12 A61B5/0095 A61B8/0841 A61B5/021 A61B5/7455 A61B6/504 A61B5/7435 A61B8/4416 G01R33/4814 A61B5/0263 A61B5/0261 A61B5/0066 A61B5/489 A61B5/743 A61B8/14 A61B8/466 A61B8/483 A61B8/5261 G01R33/5608 G06T11/001 G06T19/20 G06T2210/41 G06T2219/2012 G16H50/30		
优先权	61/710419 2012-10-05 US		
其他公开文献	US20140100442A1		
外部链接	Espacenet		

摘要(译)

用于帮助用户查看，评估和分析图像的系统和方法，尤其是内腔和内腔中包含的医疗设备的图像。用于例如通过图形用户界面与管腔和医疗设备的图像进行交互的系统和方法。

