



US 20170281955A1

(19) **United States**

(12) **Patent Application Publication**  
**Maile et al.**

(10) **Pub. No.: US 2017/0281955 A1**  
(43) **Pub. Date: Oct. 5, 2017**

(54) **IMPLANTABLE MEDICAL DEVICE WITH RECHARGEABLE BATTERY**

*A61B 5/00* (2006.01)

*A61B 5/042* (2006.01)

*A61N 1/375* (2006.01)

*A61N 1/37* (2006.01)

(71) Applicant: **CARDIAC PACEMAKERS, INC.**, St. Paul, MN (US)

(52) **U.S. Cl.**

CPC ..... *A61N 1/3787* (2013.01); *A61N 1/3756*

(2013.01); *A61N 1/37* (2013.01); *A61B 5/686*

(2013.01); *A61B 5/0422* (2013.01); *A61N*

*1/056* (2013.01); *A61B 2560/0219* (2013.01)

(72) Inventors: **Keith R. Maile**, New Brighton, MN (US); **Michael J. Kane**, St. Paul, MN (US); **William J. Linder**, Golden Valley, MN (US)

(73) Assignee: **CARDIAC PACEMAKERS, INC.**, St. Paul, MN (US)

(57)

**ABSTRACT**

(21) Appl. No.: **15/475,918**

(22) Filed: **Mar. 31, 2017**

**Related U.S. Application Data**

(60) Provisional application No. 62/316,158, filed on Mar. 31, 2016.

**Publication Classification**

(51) **Int. Cl.**

*A61N 1/378* (2006.01)

*A61N 1/05* (2006.01)

Implantable medical devices such as leadless cardiac pacemakers may include a rechargeable power source. In some cases, a system may include an implanted device including a receiving antenna and an external transmitter that transmits radiofrequency energy that may be captured by the receiving antenna and then be converted into electrical energy that may be used to recharge a rechargeable power source. Accordingly, since the rechargeable power source does not have to maintain sufficient energy stores for the expected life of the implanted device, the power source itself and thus the implanted device, may be made smaller while still meeting device longevity expectations.

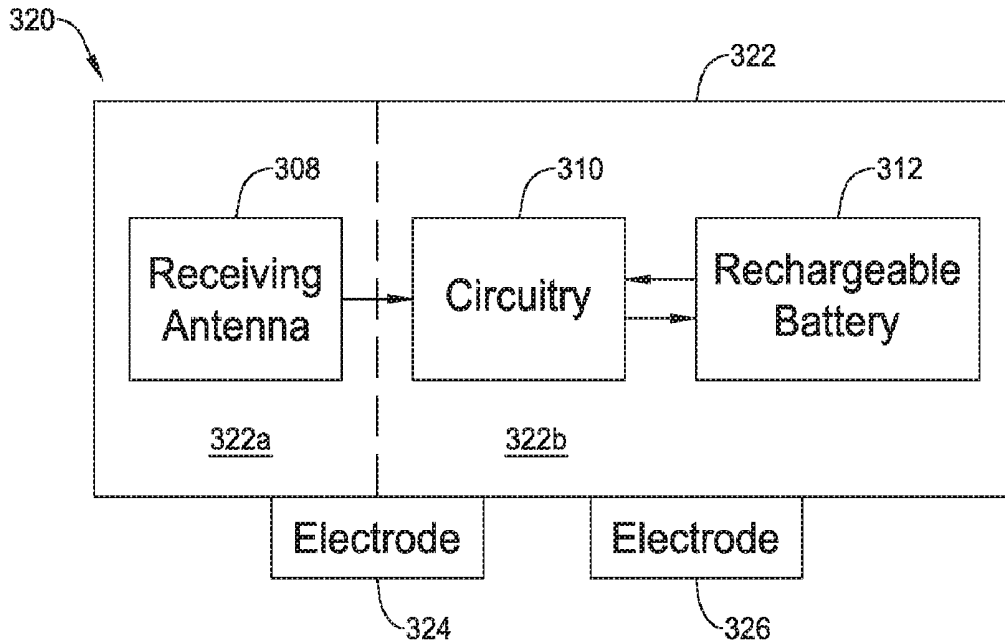

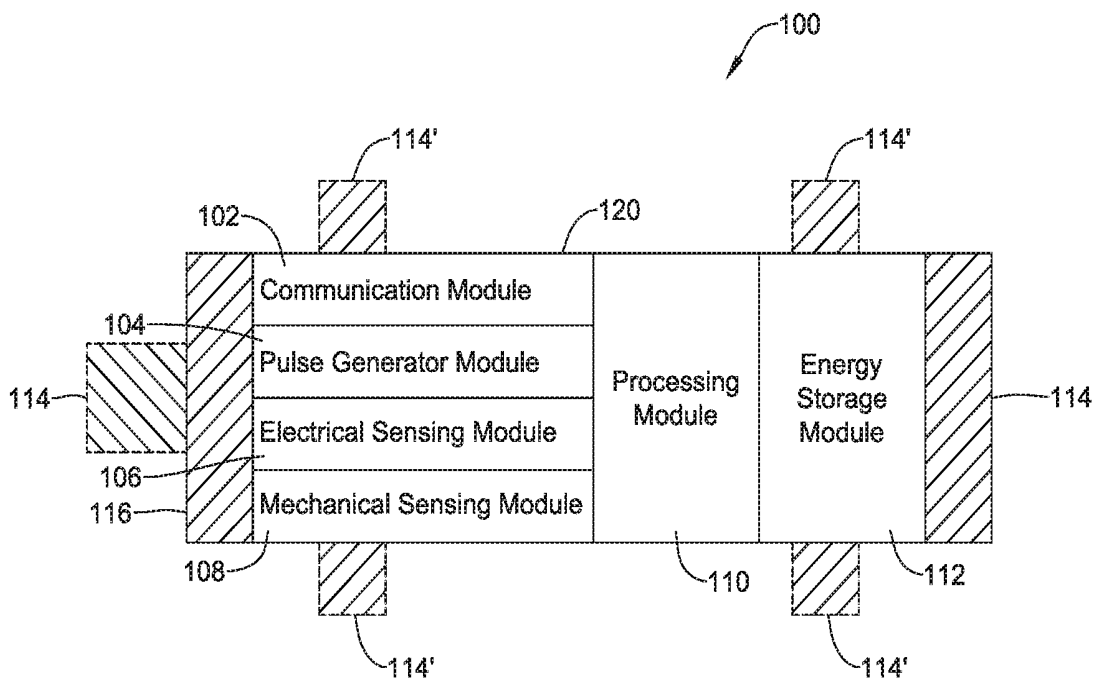

Figure 1

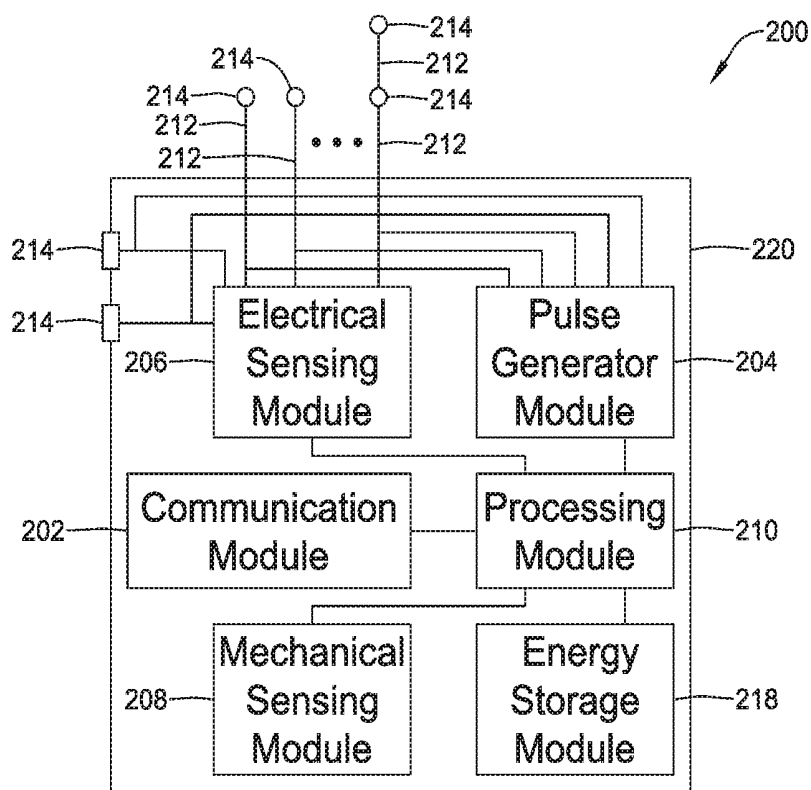

Figure 2

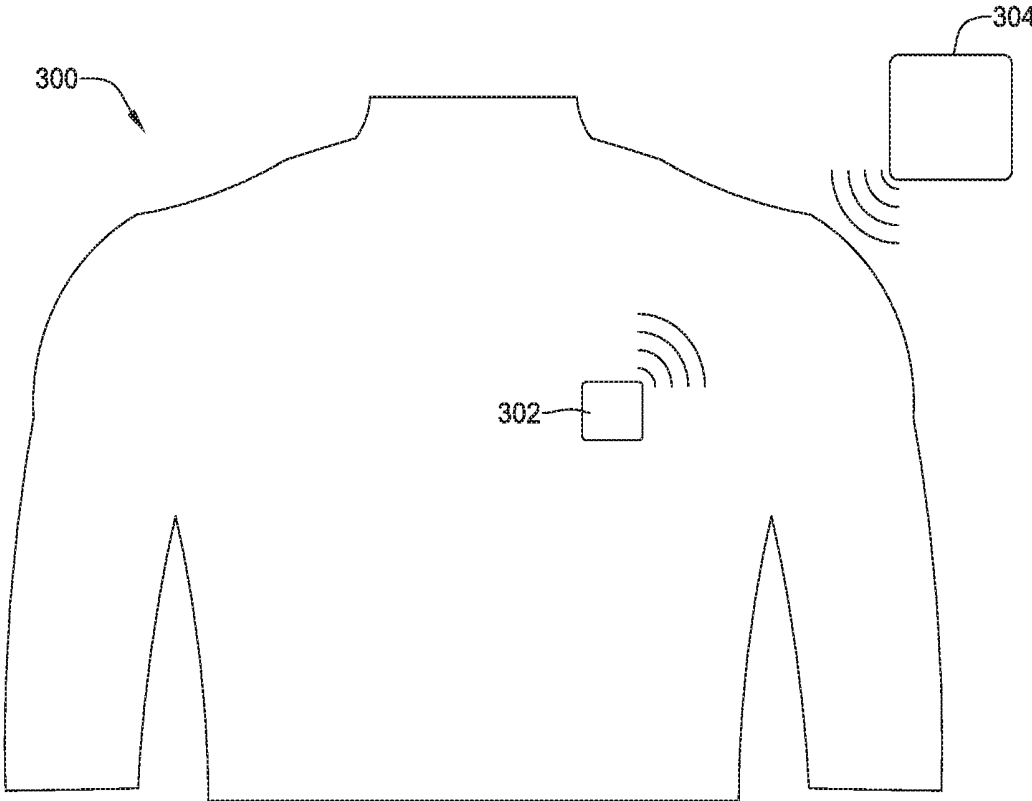

Figure 3

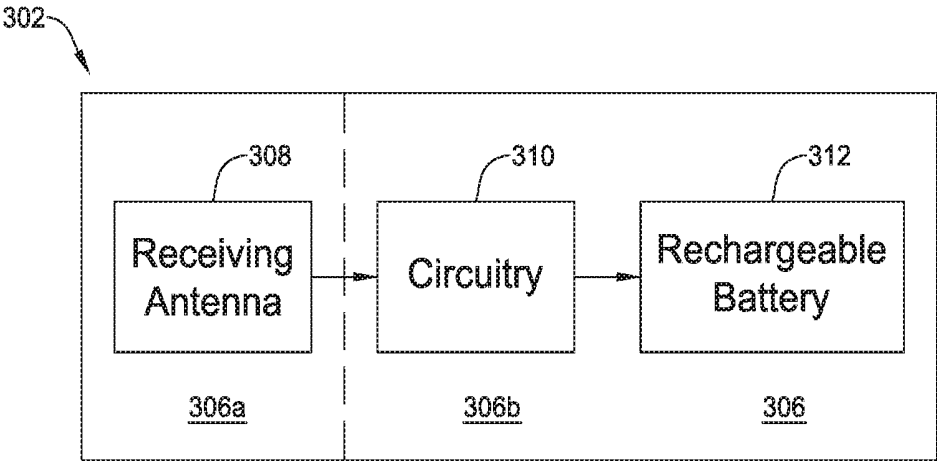

Figure 4

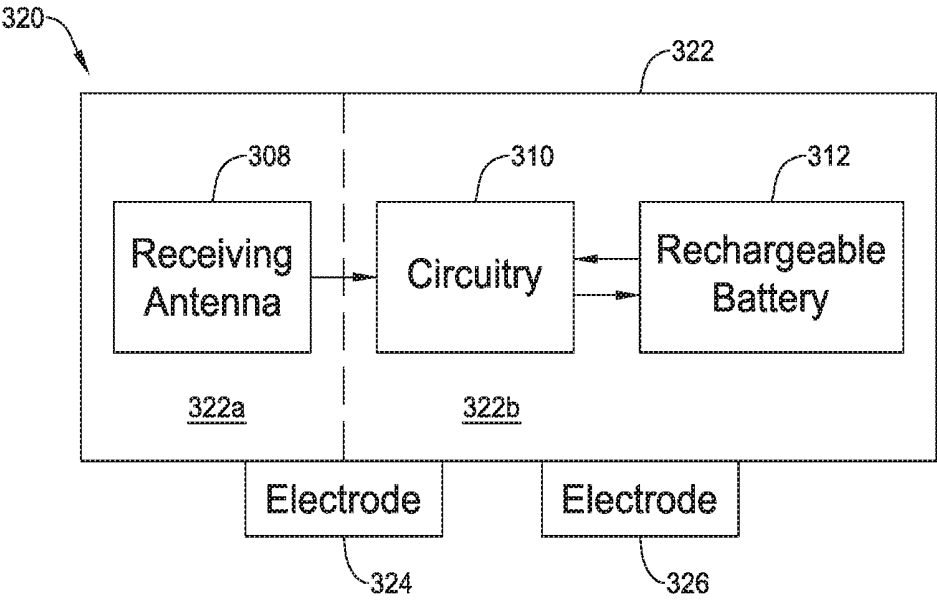

Figure 5

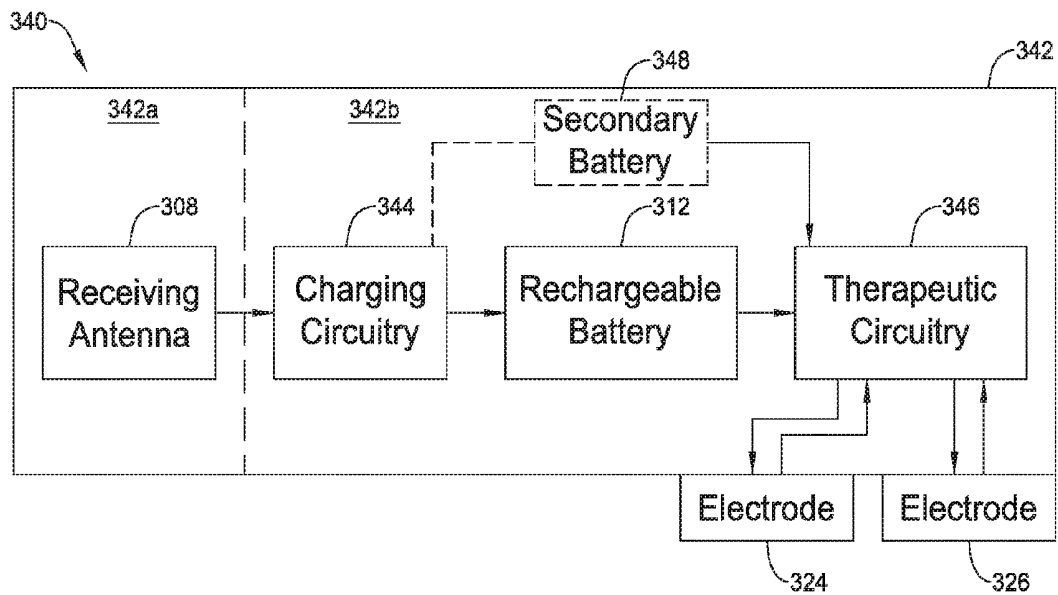

Figure 6

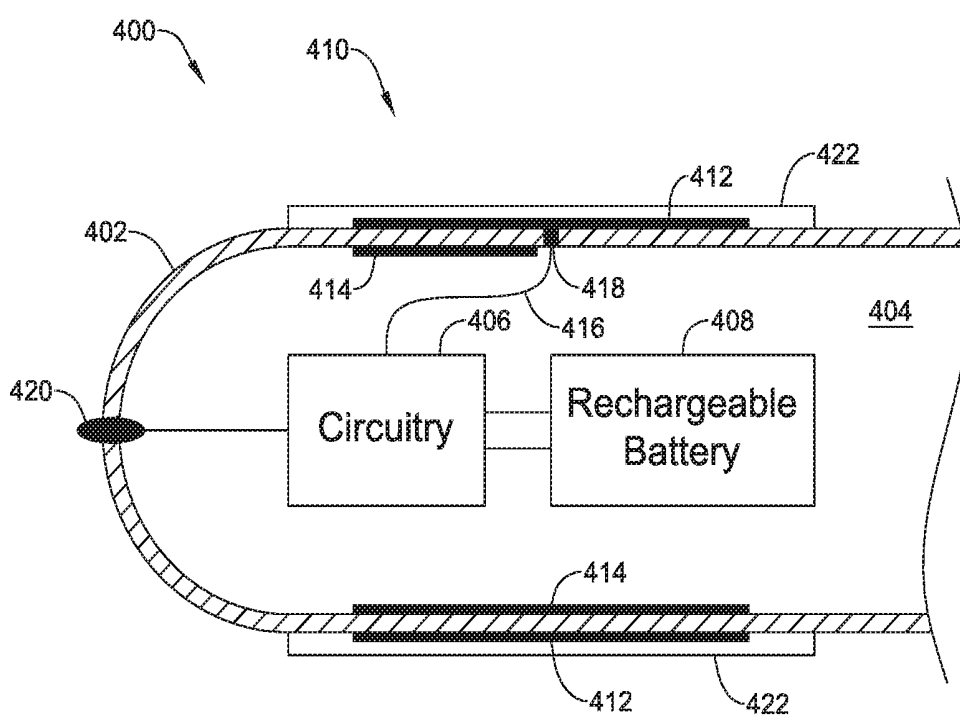

Figure 7

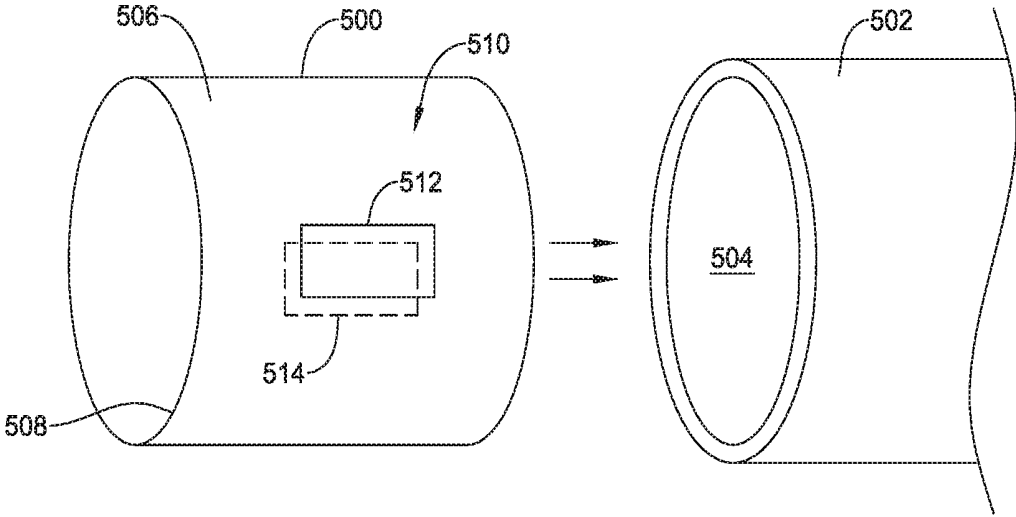

Figure 8

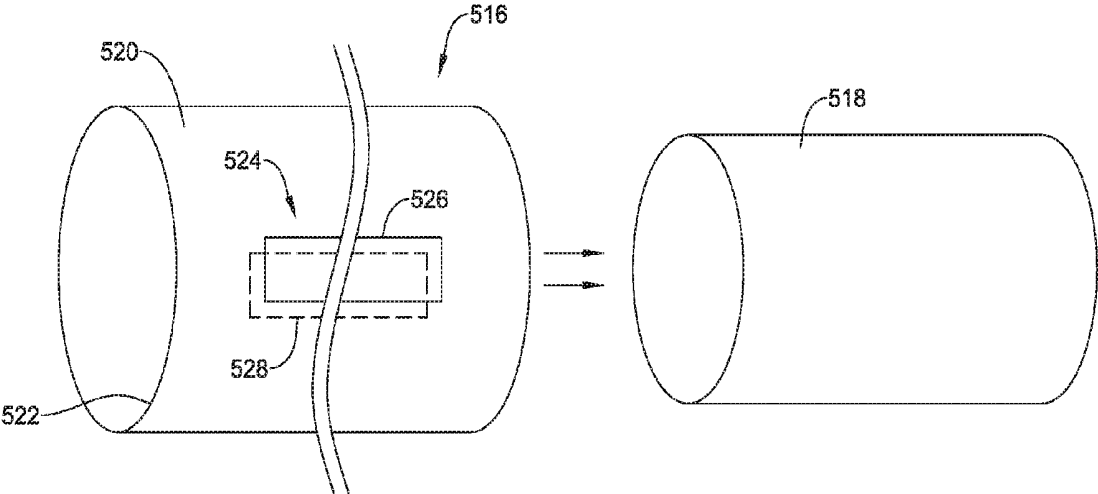

Figure 9

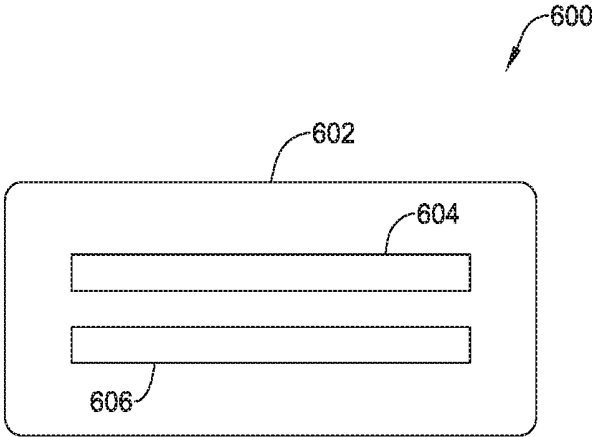

Figure 10

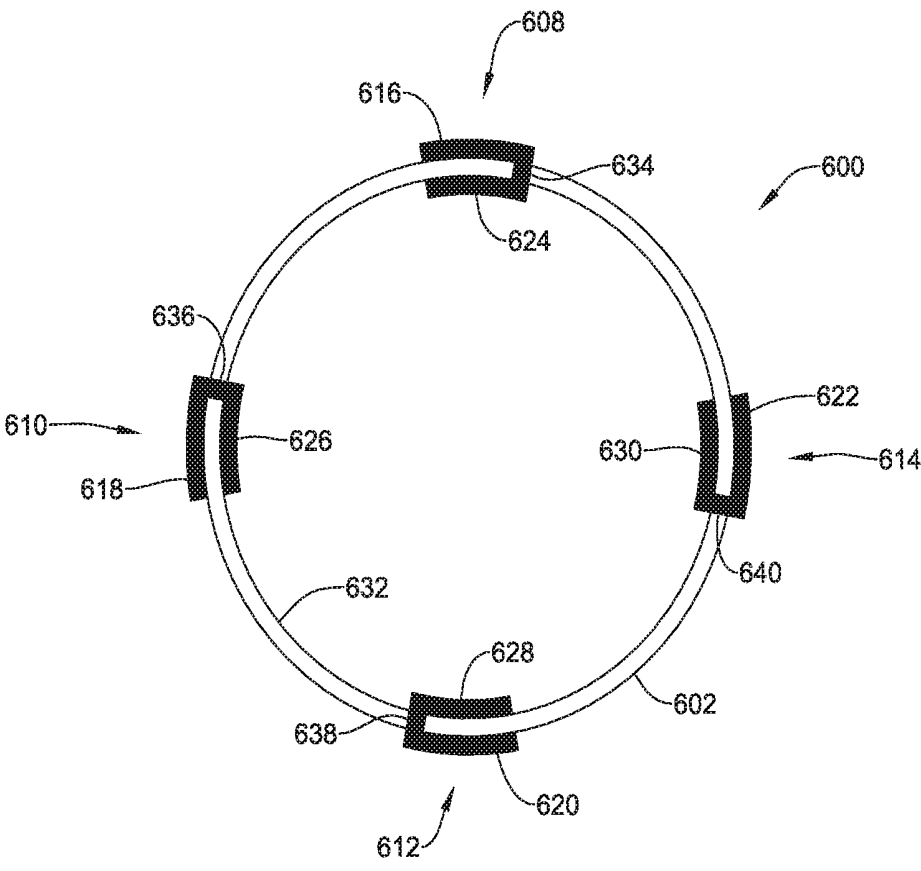

Figure 11

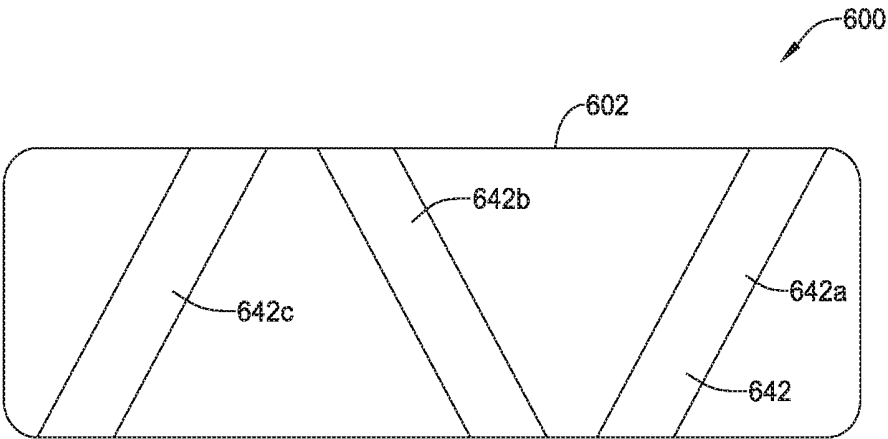

Figure 12

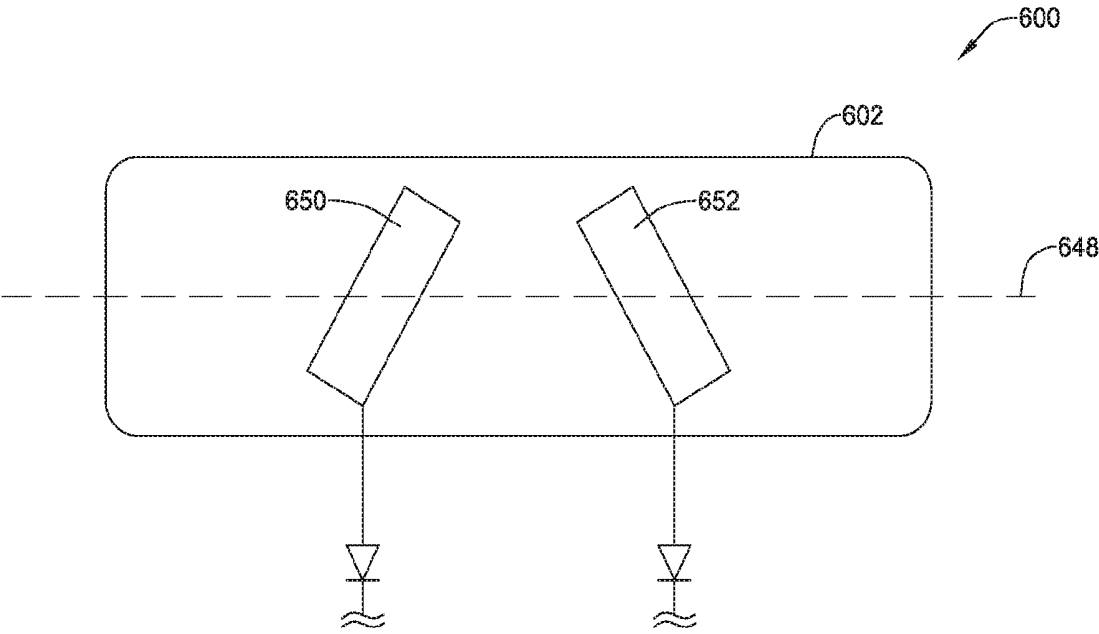

Figure 13

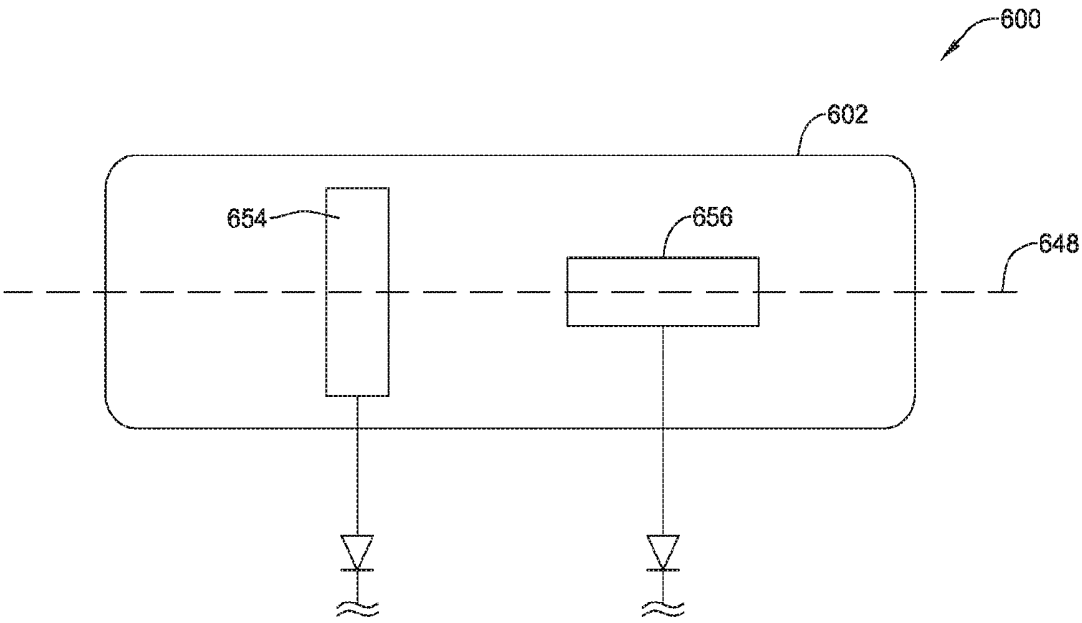

Figure 14

## IMPLANTABLE MEDICAL DEVICE WITH RECHARGEABLE BATTERY

### CROSS REFERENCE TO RELATED APPLICATIONS

[0001] This application claims the benefit of U.S. Provisional Patent Application Ser. No. 62/316,158 filed on Mar. 31, 2016, the disclosure of which is incorporated herein by reference.

### TECHNICAL FIELD

[0002] The disclosure relates generally to implantable medical devices, and more particularly to implantable medical devices that have a power source that may be wirelessly recharged from a remote location.

### BACKGROUND

[0003] Cardiac pacemakers such as leadless cardiac pacemakers are used to sense and pace hearts that are susceptible to a variety of incorrect heart rhythms, including but not limited to bradycardia, which is a slow heart rate, and tachycardia, which is a high heart rate. In many leadless cardiac pacemakers, due to their relatively small size, a relatively large fraction of the internal space of the leadless cardiac pacemaker is consumed by a battery. As the battery life determines the potential useful life expectancy of the leadless cardiac pacemaker, there is a desire to make the batteries as large as possible within the confines of the available space.

[0004] What would be desirable is an implantable medical device that has a long useful life expectancy while not requiring as much battery space, thereby permitting a significantly smaller device size. A smaller device size may make the device more easily deliverable and implantable in the body, allow the device to be implantable in smaller and more confined spaces in the body, and/or may make the device less expensive to produce.

### SUMMARY

[0005] The disclosure is directed to implantable medical devices that provide a long lasting power source within a smaller device housing. While a leadless cardiac pacemaker is used as an example implantable medical device, the disclosure may be applied to any suitable implantable medical device including, for example, neuro-stimulators, diagnostic devices including those that do not deliver therapy, and/or any other suitable implantable medical device as desired.

[0006] In some cases, the disclosure pertains to implantable medical devices such as leadless cardiac pacemakers that include a rechargeable power source such as a rechargeable battery, a rechargeable capacitor or a rechargeable supercapacitor. In some cases, a system may include an implanted device including a receiving antenna and an external transmitter that transmits radiofrequency energy that may be captured by the receiving antenna and then converted into electrical energy that may be used to recharge the rechargeable power source. Accordingly, since the rechargeable power source does not have to maintain sufficient energy stores in a single charge for the entire expected life of the implanted device, the power source itself and thus the implanted device, may be made smaller while still meeting device longevity expectations.

[0007] In an example of the disclosure, an implantable medical device (IMD) that is configured to be implanted within a patient includes a housing configured for trans-catheter deployment and a plurality of electrodes that are exposed external to the housing. Therapeutic circuitry is disposed within the housing and may be operatively coupled to the plurality of electrodes and configured to sense one or more signals via one or more of the plurality of electrodes and/or to stimulate tissue via one or more of the plurality of electrodes. A rechargeable power source may be disposed within the housing and may be configured to power the therapeutic circuitry. A receiving antenna may be disposed relative to the housing and may be configured to receive transmitted radiative Electro-Magnetic (EM) energy through the patient's body. Charging circuitry may be operably coupled with the receiving antenna and the rechargeable power source and may be configured to use the radiative EM energy received via the receiving antenna to charge the rechargeable power source.

[0008] Alternatively or additionally to any of the embodiments above, the IMD may also include a secondary battery disposed within the housing and operatively coupled to the therapeutic circuitry, the secondary battery functioning as a backup battery to the rechargeable power source.

[0009] Alternatively or additionally to any of the embodiments above, the secondary battery is a non-rechargeable battery.

[0010] Alternatively or additionally to any of the embodiments above, the IMD is a leadless cardiac pacemaker (LCP).

[0011] Alternatively or additionally to any of the embodiments above, the housing is substantially transparent to radiative EM energy.

[0012] Alternatively or additionally to any of the embodiments above, the housing may include a ceramic housing, a glass housing, or a polymeric housing.

[0013] Alternatively or additionally to any of the embodiments above, the receiving antenna may include a first metal pattern formed on an outer surface of a sleeve insert and a second metal pattern formed on an inner surface of the sleeve insert, and the sleeve insert is configured to be inserted into an elongated cavity of the housing of the IMD.

[0014] Alternatively or additionally to any of the embodiments above, the receiving antenna may include a first metal pattern formed on an outer surface of an outer sleeve and a second metal pattern formed on an inner surface of the outer sleeve, and the outer sleeve is configured to fit over and be secured relative to the housing of the IMD.

[0015] Alternatively or additionally to any of the embodiments above, at least one of the plurality of electrodes forms part of the receiving antenna.

[0016] In another example of the disclosure, an implantable medical device (IMD) configured to be implanted within a patient includes a housing that is substantially transparent to radiative Electro-Magnetic (EM) energy along at least part of its length and circuitry that is disposed within the housing. A plurality of electrodes may be exposed external to the housing and operatively coupled to the circuitry. A rechargeable power source may be disposed within the housing and may be configured to power the IMD including the circuitry. A receiving antenna may be disposed within the housing and may be configured to receive transmitted radiative EM energy through the at least part of the housing that is substantially transparent to radiative EM

energy. The circuit may be operably coupled with the receiving antenna and the rechargeable power source and be configured to use the radiative EM energy received via the receiving antenna to charge the rechargeable power source.

[0017] Alternatively or additionally to any of the embodiments above, the IMD is a leadless cardiac pacemaker (LCP).

[0018] Alternatively or additionally to any of the embodiments above, the IMD is an implantable monitoring device.

[0019] Alternatively or additionally to any of the embodiments above, the IMD is an implantable sensor.

[0020] Alternatively or additionally to any of the embodiments above, the receiving antenna may include a first receiving antenna having a first null and a second receiving antenna having a second null offset from the first null.

[0021] Alternatively or additionally to any of the embodiments above, the housing may include ceramic.

[0022] Alternatively or additionally to any of the embodiments above, the housing may include glass.

[0023] Alternatively or additionally to any of the embodiments above, the receiving antenna may be configured to receive sufficient radiative EM energy from a wavelength band of radiative EM energy transmitted from outside the patient to recharge the rechargeable power source at a rate faster than the rechargeable power source is depleted by powering the IMD when the wavelength band of radiative EM energy is transmitted at an intensity that does not cause heat damage to the patient.

[0024] Alternatively or additionally to any of the embodiments above, at least a portion of the housing has a substantially cylindrical profile and the receiving antenna includes a planar antenna that has been conformed to the substantially cylindrical profile.

[0025] In another example of the disclosure, an implantable medical device (IMD) configured to be implanted within a patient includes a housing forming at least part of a receiving antenna, wherein the receiving antenna is configured to receive transmitted radiative Electro-Magnetic (EM) energy through the patient's body. A plurality of electrodes may be exposed external to the housing and circuitry may be disposed within the housing. The circuitry may be operatively coupled to the plurality of electrodes and may be configured to sense one or more signals via one or more of the plurality of electrodes and/or may stimulate tissue via one or more of the plurality of electrodes. A rechargeable power source may be disposed within the housing and may be configured to power the circuitry. Charging circuitry may be operably coupled with the receiving antenna and the rechargeable power source and may be configured to use the radiative EM energy received via the receiving antenna to charge the rechargeable power source.

[0026] Alternatively or additionally to any of the embodiments above, the housing may form one or more layers of the receiving antenna.

[0027] The above summary of some illustrative embodiments is not intended to describe each disclosed embodiment or every implementation of the present disclosure. The Figures and Description which follow more particularly exemplify these and other illustrative embodiments.

#### BRIEF DESCRIPTION OF THE FIGURES

[0028] The disclosure may be more completely understood in consideration of the following description in connection with the accompanying drawings, in which:

[0029] FIG. 1 is a schematic block diagram of an illustrative leadless cardiac pacemaker (LCP);

[0030] FIG. 2 is a schematic block diagram of an illustrative medical device that may be used in conjunction with the LCP of FIG. 1;

[0031] FIG. 3 is a schematic diagram of a patient including a rechargeable implantable medical device system;

[0032] FIG. 4 is a schematic diagram of an illustrative implantable medical device (IMD) according to an example of the disclosure;

[0033] FIG. 5 is a schematic diagram of another illustrative IMD according to an example of the disclosure;

[0034] FIG. 6 is a schematic diagram of another IMD according to an example of the disclosure;

[0035] FIG. 7 is a partial cross-sectional side view of an LCP according to an example of the disclosure;

[0036] FIG. 8 is a schematic diagram of an illustrative IMD with an inner sleeve insert;

[0037] FIG. 9 is a schematic diagram of an illustrative IMD with an outer sleeve; and

[0038] FIGS. 10-14 are schematic diagrams showing example receiving antenna configurations.

[0039] While the disclosure is amenable to various modifications and alternative forms, specifics thereof have been shown by way of example in the drawings and will be described in detail. It should be understood, however, that the intention is not to limit the disclosure to the particular embodiments described. On the contrary, the intention is to cover all modifications, equivalents, and alternatives falling within the spirit and scope of the disclosure.

#### DESCRIPTION

[0040] For the following defined terms, these definitions shall be applied, unless a different definition is given in the claims or elsewhere in this specification.

[0041] All numeric values are herein assumed to be modified by the term "about," whether or not explicitly indicated. The term "about" generally refers to a range of numbers that one of skill in the art would consider equivalent to the recited value (i.e., having the same function or result). In many instances, the terms "about" may include numbers that are rounded to the nearest significant figure.

[0042] The recitation of numerical ranges by endpoints includes all numbers within that range (e.g. 1 to 5 includes 1, 1.5, 2, 2.75, 3, 3.80, 4, and 5).

[0043] As used in this specification and the appended claims, the singular forms "a", "an", and "the" include plural referents unless the content clearly dictates otherwise. As used in this specification and the appended claims, the term "or" is generally employed in its sense including "and/or" unless the content clearly dictates otherwise.

[0044] It is noted that references in the specification to "an embodiment", "some embodiments", "other embodiments", etc., indicate that the embodiment described may include one or more particular features, structures, and/or characteristics. However, such recitations do not necessarily mean that all embodiments include the particular features, structures, and/or characteristics. Additionally, when particular features, structures, and/or characteristics are described in connection with one embodiment, it should be understood that such features, structures, and/or characteristics may also be used connection with other embodiments whether or not explicitly described unless clearly stated to the contrary.

[0045] The following description should be read with reference to the drawings in which similar structures in different drawings are numbered the same. The drawings, which are not necessarily to scale, depict illustrative embodiments and are not intended to limit the scope of the disclosure.

[0046] FIG. 1 is a conceptual schematic block diagram of an illustrative leadless cardiac pacemaker (LCP) that may be implanted on the heart or within a chamber of the heart and may operate to sense physiological signals and parameters and deliver one or more types of electrical stimulation therapy to the heart of the patient. Example electrical stimulation therapy may include bradycardia pacing, rate responsive pacing therapy, cardiac resynchronization therapy (CRT), anti-tachycardia pacing (ATP) therapy and/or the like. As can be seen in FIG. 1, the LCP 100 may be a compact device with all components housed within the LCP 100 or directly on a housing 120. In some instances, the LCP 100 may include one or more of a communication module 102, a pulse generator module 104, an electrical sensing module 106, a mechanical sensing module 108, a processing module 110, an energy storage module 112, and electrodes 114.

[0047] As depicted in FIG. 1, the LCP 100 may include electrodes 114, which can be secured relative to the housing 120 and electrically exposed to tissue and/or blood surrounding the LCP 100. The electrodes 114 may generally conduct electrical signals to and from the LCP 100 and the surrounding tissue and/or blood. Such electrical signals can include communication signals, electrical stimulation pulses, and intrinsic cardiac electrical signals, to name a few. Intrinsic cardiac electrical signals may include electrical signals generated by the heart and may be represented by an electrocardiogram (ECG).

[0048] The electrodes 114 may include one or more bio-compatible conductive materials such as various metals or alloys that are known to be safe for implantation within a human body. In some instances, the electrodes 114 may be generally disposed on either end of the LCP 100 and may be in electrical communication with one or more of modules the 102, 104, 106, 108, and 110. In embodiments where the electrodes 114 are secured directly to the housing 120, an insulative material may electrically isolate the electrodes 114 from adjacent electrodes, the housing 120, and/or other parts of the LCP 100. In some instances, some or all of the electrodes 114 may be spaced from the housing 120 and may be connected to the housing 120 and/or other components of the LCP 100 through connecting wires. In such instances, the electrodes 114 may be placed on a tail (not shown) that extends out away from the housing 120. As shown in FIG. 1, in some embodiments, the LCP 100 may include electrodes 114'. The electrodes 114' may be in addition to the electrodes 114, or may replace one or more of the electrodes 114. The electrodes 114' may be similar to the electrodes 114 except that the electrodes 114' are disposed on the sides of the LCP 100. In some cases, the electrodes 114' may increase the number of electrodes by which the LCP 100 may deliver communication signals and/or electrical stimulation pulses, and/or may sense intrinsic cardiac electrical signals, communication signals, and/or electrical stimulation pulses.

[0049] The electrodes 114 and/or 114' may assume any of a variety of sizes and/or shapes, and may be spaced at any of a variety of spacings. For example, the electrodes 114 may have an outer diameter of two to twenty millimeters

(mm). In other embodiments, the electrodes 114 and/or 114' may have a diameter of two, three, five, seven millimeters (mm), or any other suitable diameter, dimension and/or shape. Example lengths for the electrodes 114 and/or 114' may include, for example, one, three, five, ten millimeters (mm), or any other suitable length. As used herein, the length is a dimension of the electrodes 114 and/or 114' that extends away from the outer surface of the housing 120. In some instances, at least some of the electrodes 114 and/or 114' may be spaced from one another by a distance of twenty, thirty, forty, fifty millimeters (mm), or any other suitable spacing. The electrodes 114 and/or 114' of a single device may have different sizes with respect to each other, and the spacing and/or lengths of the electrodes on the device may or may not be uniform.

[0050] In the embodiment shown, the communication module 102 may be electrically coupled to the electrodes 114 and/or 114' and may be configured to deliver communication pulses to tissues of the patient for communicating with other devices such as sensors, programmers, other medical devices, and/or the like. Communication signals, as used herein, may be any modulated signal that conveys information to another device, either by itself or in conjunction with one or more other modulated signals. In some embodiments, communication signals may be limited to sub-threshold signals that do not result in capture of the heart yet still convey information. The communication signals may be delivered to another device that is located either external or internal to the patient's body. In some instances, the communication may take the form of distinct communication pulses separated by various amounts of time. In some of these cases, the timing between successive pulses may convey information. The communication module 102 may additionally be configured to sense for communication signals delivered by other devices, which may be located external or internal to the patient's body.

[0051] The communication module 102 may communicate to help accomplish one or more desired functions. Some example functions include delivering sensed data, using communicated data for determining occurrences of events such as arrhythmias, coordinating delivery of electrical stimulation therapy, and/or other functions. In some cases, the LCP 100 may use communication signals to communicate raw information, processed information, messages and/or commands, and/or other data. Raw information may include information such as sensed electrical signals (e.g. a sensed ECG), signals gathered from coupled sensors, and the like. In some embodiments, the processed information may include signals that have been filtered using one or more signal processing techniques. Processed information may also include parameters and/or events that are determined by the LCP 100 and/or another device, such as a determined heart rate, timing of determined heartbeats, timing of other determined events, determinations of threshold crossings, expirations of monitored time periods, accelerometer signals, activity level parameters, blood-oxygen parameters, blood pressure parameters, heart sound parameters, and the like. In some cases, processed information may, for example, be provided by a chemical sensor or an optically interfaced sensor. Messages and/or commands may include instructions or the like directing another device to take action, notifications of imminent actions of the sending device, requests for reading from the receiving device,

requests for writing data to the receiving device, information messages, and/or other messages commands.

[0052] In at least some embodiments, the communication module 102 (or the LCP 100) may further include switching circuitry to selectively connect one or more of the electrodes 114 and/or 114' to the communication module 102 in order to select which of the electrodes 114 and/or 114' that the communication module 102 delivers communication pulses with. It is contemplated that the communication module 102 may be communicating with other devices via conducted signals, radio frequency (RF) signals, optical signals, acoustic signals, inductive coupling, and/or any other suitable communication methodology. Where the communication module 102 generates electrical communication signals, the communication module 102 may include one or more capacitor elements and/or other charge storage devices to aid in generating and delivering communication signals. In the embodiment shown, the communication module 102 may use energy stored in the energy storage module 112 to generate the communication signals. In at least some examples, the communication module 102 may include a switching circuit that is connected to the energy storage module 112 and, with the switching circuitry, may connect the energy storage module 112 to one or more of the electrodes 114/114' to generate the communication signals.

[0053] As shown in FIG. 1, a pulse generator module 104 may be electrically connected to one or more of the electrodes 114 and/or 114'. The pulse generator module 104 may be configured to generate electrical stimulation pulses and deliver the electrical stimulation pulses to tissues of a patient via one or more of the electrodes 114 and/or 114' in order to effectuate one or more electrical stimulation therapies. Electrical stimulation pulses as used herein are meant to encompass any electrical signals that may be delivered to tissue of a patient for purposes of treatment of any type of disease or abnormality. For example, when used to treat heart disease, the pulse generator module 104 may generate electrical stimulation pacing pulses for capturing the heart of the patient, i.e. causing the heart to contract in response to the delivered electrical stimulation pulse. In some of these cases, the LCP 100 may vary the rate at which the pulse generator module 104 generates the electrical stimulation pulses, for example in rate adaptive pacing. In other embodiments, the electrical stimulation pulses may include defibrillation/cardioversion pulses for shocking the heart out of fibrillation or into a normal heart rhythm. In yet other embodiments, the electrical stimulation pulses may include anti-tachycardia pacing (ATP) pulses. It should be understood that these are just some examples. When used to treat other ailments, the pulse generator module 104 may generate electrical stimulation pulses suitable for neurostimulation therapy or the like. The pulse generator module 104 may include one or more capacitor elements and/or other charge storage devices to aid in generating and delivering appropriate electrical stimulation pulses. In at least some embodiments, the pulse generator module 104 may use energy stored in the energy storage module 112 to generate the electrical stimulation pulses. In some particular embodiments, the pulse generator module 104 may include a switching circuit that is connected to the energy storage module 112 and may connect the energy storage module 112 to one or more of the electrodes 114/114' to generate electrical stimulation pulses.

[0054] The LCP 100 may further include an electrical sensing module 106 and a mechanical sensing module 108. The electrical sensing module 106 may be configured to sense intrinsic cardiac electrical signals conducted from the electrodes 114 and/or 114' to the electrical sensing module 106. For example, the electrical sensing module 106 may be electrically connected to one or more of the electrodes 114 and/or 114' and the electrical sensing module 106 may be configured to receive cardiac electrical signals conducted through the electrodes 114 and/or 114' via a sensor amplifier or the like. In some embodiments, the cardiac electrical signals may represent local information from the chamber in which the LCP 100 is implanted. For instance, if the LCP 100 is implanted within a ventricle of the heart, cardiac electrical signals sensed by the LCP 100 through the electrodes 114 and/or 114' may represent ventricular cardiac electrical signals. The mechanical sensing module 108 may include, or be electrically connected to, various sensors, such as accelerometers, including multi-axis accelerometers such as two- or three-axis accelerometers, gyroscopes, including multi-axis gyroscopes such as two- or three-axis gyroscopes, blood pressure sensors, heart sound sensors, piezoelectric sensors, blood-oxygen sensors, and/or other sensors which measure one or more physiological parameters of the heart and/or patient. Mechanical sensing module 108, when present, may gather signals from the sensors indicative of the various physiological parameters. The electrical sensing module 106 and the mechanical sensing module 108 may both be connected to the processing module 110 and may provide signals representative of the sensed cardiac electrical signals and/or physiological signals to the processing module 110. Although described with respect to FIG. 1 as separate sensing modules, in some embodiments, the electrical sensing module 106 and the mechanical sensing module 108 may be combined into a single module. In at least some examples, the LCP 100 may only include one of the electrical sensing module 106 and the mechanical sensing module 108. In some cases, any combination of the processing module 110, the electrical sensing module 106, the mechanical sensing module 108, the communication module 102, the pulse generator module 104 and/or the energy storage module may be considered a controller of the LCP 100.

[0055] The processing module 110 may be configured to direct the operation of the LCP 100 and may, in some embodiments, be termed a controller. For example, the processing module 110 may be configured to receive cardiac electrical signals from the electrical sensing module 106 and/or physiological signals from the mechanical sensing module 108. Based on the received signals, the processing module 110 may determine, for example, occurrences and types of arrhythmias and other determinations such as whether the LCP 100 has become dislodged. The processing module 110 may further receive information from the communication module 102. In some embodiments, the processing module 110 may additionally use such received information to determine occurrences and types of arrhythmias and/or other determinations such as whether the LCP 100 has become dislodged. In still some additional embodiments, the LCP 100 may use the received information instead of the signals received from the electrical sensing module 106 and/or the mechanical sensing module 108—for instance if the received information is deemed to be more accurate than the signals received from the electrical sensing

module **106** and/or the mechanical sensing module **108** or if the electrical sensing module **106** and/or the mechanical sensing module **108** have been disabled or omitted from the LCP **100**.

[0056] After determining an occurrence of an arrhythmia, the processing module **110** may control the pulse generator module **104** to generate electrical stimulation pulses in accordance with one or more electrical stimulation therapies to treat the determined arrhythmia. For example, the processing module **110** may control the pulse generator module **104** to generate pacing pulses with varying parameters and in different sequences to effectuate one or more electrical stimulation therapies. As one example, in controlling the pulse generator module **104** to deliver bradycardia pacing therapy, the processing module **110** may control the pulse generator module **104** to deliver pacing pulses designed to capture the heart of the patient at a regular interval to help prevent the heart of a patient from falling below a predetermined threshold. In some cases, the rate of pacing may be increased with an increased activity level of the patient (e.g. rate adaptive pacing). For instance, the processing module **110** may monitor one or more physiological parameters of the patient which may indicate a need for an increased heart rate (e.g. due to increased metabolic demand). The processing module **110** may then increase the rate at which the pulse generator module **104** generates electrical stimulation pulses. Adjusting the rate of delivery of the electrical stimulation pulses based on the one or more physiological parameters may extend the battery life of the LCP **100** by only requiring higher rates of delivery of electrical stimulation pulses when the physiological parameters indicate there is a need for increased cardiac output. Additionally, adjusting the rate of delivery of the electrical stimulation pulses may increase a comfort level of the patient by more closely matching the rate of delivery of electrical stimulation pulses with the cardiac output need of the patient.

[0057] For ATP therapy, the processing module **110** may control the pulse generator module **104** to deliver pacing pulses at a rate faster than an intrinsic heart rate of a patient in attempt to force the heart to beat in response to the delivered pacing pulses rather than in response to intrinsic cardiac electrical signals. Once the heart is following the pacing pulses, the processing module **110** may control the pulse generator module **104** to reduce the rate of delivered pacing pulses down to a safer level. In CRT, the processing module **110** may control the pulse generator module **104** to deliver pacing pulses in coordination with another device to cause the heart to contract more efficiently. In cases where the pulse generator module **104** is capable of generating defibrillation and/or cardioversion pulses for defibrillation/cardioversion therapy, the processing module **110** may control the pulse generator module **104** to generate such defibrillation and/or cardioversion pulses. In some cases, the processing module **110** may control the pulse generator module **104** to generate electrical stimulation pulses to provide electrical stimulation therapies different than those examples described above.

[0058] Aside from controlling the pulse generator module **104** to generate different types of electrical stimulation pulses and in different sequences, in some embodiments, the processing module **110** may also control the pulse generator module **104** to generate the various electrical stimulation pulses with varying pulse parameters. For example, each electrical stimulation pulse may have a pulse width and a

pulse amplitude. The processing module **110** may control the pulse generator module **104** to generate the various electrical stimulation pulses with specific pulse widths and pulse amplitudes. For example, the processing module **110** may cause the pulse generator module **104** to adjust the pulse width and/or the pulse amplitude of electrical stimulation pulses if the electrical stimulation pulses are not effectively capturing the heart. Such control of the specific parameters of the various electrical stimulation pulses may help the LCP **100** provide more effective delivery of electrical stimulation therapy.

[0059] In some embodiments, the processing module **110** may further control the communication module **102** to send information to other devices. For example, the processing module **110** may control the communication module **102** to generate one or more communication signals for communicating with other devices of a system of devices. For instance, the processing module **110** may control the communication module **102** to generate communication signals in particular pulse sequences, where the specific sequences convey different information. The communication module **102** may also receive communication signals for potential action by the processing module **110**.

[0060] In further embodiments, the processing module **110** may control switching circuitry by which the communication module **102** and the pulse generator module **104** deliver communication signals and/or electrical stimulation pulses to tissue of the patient. As described above, both the communication module **102** and the pulse generator module **104** may include circuitry for connecting one or more of the electrodes **114** and/or **114'** to the communication module **102** and/or the pulse generator module **104** so those modules may deliver the communication signals and electrical stimulation pulses to tissue of the patient. The specific combination of one or more electrodes by which the communication module **102** and/or the pulse generator module **104** deliver communication signals and electrical stimulation pulses may influence the reception of communication signals and/or the effectiveness of electrical stimulation pulses. Although it was described that each of the communication module **102** and the pulse generator module **104** may include switching circuitry, in some embodiments, the LCP **100** may have a single switching module connected to the communication module **102**, the pulse generator module **104**, and the electrodes **114** and/or **114'**. In such embodiments, processing module **110** may control the switching module to connect the modules **102/104** and the electrodes **114/114'** as appropriate.

[0061] In some embodiments, the processing module **110** may include a pre-programmed chip, such as a very-large-scale integration (VLSI) chip or an application specific integrated circuit (ASIC). In such embodiments, the chip may be pre-programmed with control logic in order to control the operation of the LCP **100**. By using a pre-programmed chip, the processing module **110** may use less power than other programmable circuits while able to maintain basic functionality, thereby potentially increasing the battery life of the LCP **100**. In other instances, the processing module **110** may include a programmable microprocessor or the like. Such a programmable microprocessor may allow a user to adjust the control logic of the LCP **100** after manufacture, thereby allowing for greater flexibility of the LCP **100** than when using a pre-programmed chip. In still other embodiments, the processing module **110** may not be

a single component. For example, the processing module 110 may include multiple components positioned at separate locations within the LCP 100 in order to perform the various described functions. For example, certain functions may be performed in one component of the processing module 110, while other functions are performed in a separate component of the processing module 110.

[0062] The processing module 110, in additional embodiments, may include a memory circuit and the processing module 110 may store information on and read information from the memory circuit. In other embodiments, the LCP 100 may include a separate memory circuit (not shown) that is in communication with the processing module 110, such that the processing module 110 may read and write information to and from the separate memory circuit. The memory circuit, whether part of the processing module 110 or separate from the processing module 110, may be volatile memory, non-volatile memory, or a combination of volatile memory and non-volatile memory.

[0063] The energy storage module 112 may provide a power source to the LCP 100 for its operations. In some embodiments, the energy storage module 112 may be a non-rechargeable lithium-based battery. In other embodiments, the non-rechargeable battery may be made from other suitable materials. In some embodiments, the energy storage module 112 may be considered to be a rechargeable power supply, such as but not limited to, a rechargeable battery. In still other embodiments, the energy storage module 112 may include other types of energy storage devices such as capacitors or super capacitors. In some cases, as will be discussed, the energy storage module 112 may include a rechargeable primary battery and a non-rechargeable secondary battery. In some cases, the primary battery and the second battery, if present, may both be rechargeable.

[0064] To implant the LCP 100 inside a patient's body, an operator (e.g., a physician, clinician, etc.), may fix the LCP 100 to the cardiac tissue of the patient's heart. To facilitate fixation, the LCP 100 may include one or more anchors 116. The one or more anchors 116 are shown schematically in FIG. 1. The one or more anchors 116 may include any number of fixation or anchoring mechanisms. For example, one or more anchors 116 may include one or more pins, staples, threads, screws, helix, tines, and/or the like. In some embodiments, although not shown, one or more anchors 116 may include threads on its external surface that may run along at least a partial length of an anchor member. The threads may provide friction between the cardiac tissue and the anchor to help fix the anchor member within the cardiac tissue. In some cases, the one or more anchors 116 may include an anchor member that has a cork-screw shape that can be screwed into the cardiac tissue. In other embodiments, the anchor 116 may include other structures such as barbs, spikes, or the like to facilitate engagement with the surrounding cardiac tissue.

[0065] In some examples, the LCP 100 may be configured to be implanted on a patient's heart or within a chamber of the patient's heart. For instance, the LCP 100 may be implanted within any of a left atrium, right atrium, left ventricle, or right ventricle of a patient's heart. By being implanted within a specific chamber, the LCP 100 may be able to sense cardiac electrical signals originating or emanating from the specific chamber that other devices may not be able to sense with such resolution. Where the LCP 100 is configured to be implanted on a patient's heart, the LCP 100

may be configured to be implanted on or adjacent to one of the chambers of the heart, or on or adjacent to a path along which intrinsically generated cardiac electrical signals generally follow. In these examples, the LCP 100 may also have an enhanced ability to sense localized intrinsic cardiac electrical signals and deliver localized electrical stimulation therapy. In embodiments where the LCP 100 includes an accelerometer, the LCP 100 may additionally be able to sense the motion of the cardiac wall to which the LCP 100 is attached.

[0066] While a leadless cardiac pacemaker is used as an example implantable medical device in FIG. 1, the disclosure may be applied to any suitable implantable medical device including, for example, neuro-stimulators, diagnostic devices including those that do not deliver therapy, and/or any other suitable implantable medical device as desired.

[0067] FIG. 2 is a schematic block diagram of an illustrative medical device (MD) 200 that may be used in conjunction with the LCP 100 of FIG. 1. In some cases, The MD 200 may be configured to sense physiological signals and parameters and deliver one or more types of electrical stimulation therapy to tissues of the patient. In the embodiment shown, the MD 200 may include a communication module 202, a pulse generator module 204, an electrical sensing module 206, a mechanical sensing module 208, a processing module 210, and an energy storage module 218. Each of the modules 202, 204, 206, 208, and 210 may be similar to the modules 102, 104, 106, 108, and 110 of the LCP 100. Additionally, the energy storage module 218 may be similar to the energy storage module 112 of LCP 100. However, in some embodiments, the MD 200 may have a larger volume within a housing 220. In such embodiments, the MD 200 may include a larger energy storage module 218 and/or a larger processing module 210 capable of handling more complex operations than the processing module 110 of the LCP 100.

[0068] While the MD 200 may be another leadless device such as shown in FIG. 1, in some instances the MD 200 may include leads, such as leads 212. In some instances, the leads 212 may include electrical wires that conduct electrical signals between the electrodes 214 and one or more modules located within the housing 220. In some cases, the leads 212 may be connected to and extend away from the housing 220 of the MD 200. In some embodiments, the leads 212 are implanted on, within, or adjacent to a heart of a patient. The leads 212 may contain one or more electrodes 214 positioned at various locations on the leads 212 and various distances from the housing 220. Some leads 212 may only include a single electrode 214, while other leads 212 may include multiple electrodes 214. Generally, the electrodes 214 are positioned on the leads 212 such that when the leads 212 are implanted within the patient, one or more of the electrodes 214 are positioned to perform a desired function. In some cases, the one or more of the electrodes 214 may be in contact with the patient's cardiac tissue. In other cases, the one or more of the electrodes 214 may be positioned subcutaneously but adjacent the patient's heart. The electrodes 214 may conduct intrinsically generated electrical cardiac signals to the leads 212. The leads 212 may, in turn, conduct the received electrical cardiac signals to one or more of the modules 202, 204, 206, and 208 of the MD 200. In some cases, the MD 200 may generate electrical stimulation signals, and the leads 212 may conduct the generated electrical stimulation signals to the electrodes 214. The electrodes 214 may then conduct the electrical stimulation

signals to the cardiac tissue of the patient (either directly or indirectly). The MD 200 may also include one or more electrodes 214 not disposed on a lead 212. For example, one or more electrodes 214 may be connected directly to the housing 220.

[0069] The leads 212, in some embodiments, may additionally contain one or more sensors, such as accelerometers, blood pressure sensors, heart sound sensors, blood-oxygen sensors, and/or other sensors which are configured to measure one or more physiological parameters of the heart and/or patient. In such embodiments, the mechanical sensing module 208 may be in electrical communication with the leads 212 and may receive signals generated from such sensors. In some cases, one or more of these additional sensors may instead be incorporated into or onto the MD 200.

[0070] While not required, in some embodiments the MD 200 may be an implantable medical device. In such embodiments, the housing 220 of MD 200 may be implanted in, for example, a transthoracic region of the patient. The housing 220 may generally include any of a number of known materials that are safe for implantation in a human body and may, when implanted, hermetically seal the various components of the MD 200 from fluids and tissues of the patient's body. In such embodiments, the leads 212 may be implanted at one or more various locations within the patient, such as within the heart of the patient, adjacent to the heart of the patient, adjacent to the spine of the patient, or any other desired location.

[0071] In some embodiments, the MD 200 may be an implantable cardiac pacemaker (ICP). In these embodiments, the MD 200 may have one or more leads, for example leads 212, which are implanted on or within the patient's heart. The one or more leads 212 may include one or more electrodes 214 that are in contact with cardiac tissue and/or blood of the patient's heart. The MD 200 may be configured to sense intrinsically generated cardiac electrical signals and determine, for example, one or more cardiac arrhythmias based on analysis of the sensed signals. The MD 200 may be configured to deliver CRT, ATP therapy, bradycardia therapy, and/or other therapy types via the leads 212 implanted within the heart. In some embodiments, the MD 200 may additionally be configured to provide defibrillation/cardioversion therapy.

[0072] In some instances, the MD 200 may be an implantable cardioverter-defibrillator (ICD). In such embodiments, the MD 200 may include one or more leads implanted within a patient's heart. The MD 200 may also be configured to sense electrical cardiac signals, determine occurrences of tachyarrhythmia's based on the sensed electrical cardiac signals, and deliver defibrillation and/or cardioversion therapy in response to determining an occurrence of a tachyarrhythmia (for example by delivering defibrillation and/or cardioversion pulses to the heart of the patient). In other embodiments, the MD 200 may be a subcutaneous implantable cardioverter-defibrillator (SICD). In embodiments where the MD 200 is an SICD, one of the leads 212 may be a subcutaneously implanted lead. In at least some embodiments where the MD 200 is an SICD, the MD 200 may include only a single lead which is implanted subcutaneously but outside of the chest cavity, however this is not required. In some cases, the lead may be implanted just under the chest cavity.

[0073] In some embodiments, the MD 200 may not be an implantable medical device. Rather, the MD 200 may be a device external to the patient's body, and the electrodes 214 may be skin-electrodes that are placed on a patient's body. In such embodiments, the MD 200 may be able to sense surface electrical signals (e.g. electrical cardiac signals that are generated by the heart or electrical signals generated by a device implanted within a patient's body and conducted through the body to the skin). The MD 200 may further be configured to deliver various types of electrical stimulation therapy, including, for example, defibrillation therapy via skin-electrodes 214.

[0074] In some cases, implantable medical devices such as the IMD 100 and/or the MD 200 devote a substantial portion of their internal volume to energy storage. It will be appreciated that the life expectancy of an implanted device depends in large part upon the life expectancy of the battery powering the implanted device. Accordingly, there are competing interests in wanting to maximize battery life (and hence device life expectancy) while making implanted devices as small as possible in order to facilitate delivery using various techniques such as trans-catheter delivery as well as to make the implanted devices less intrusive. In some cases, such as for implanted devices intended to be implanted in particular chambers of the heart, there are additional potential size limitations. A device that is too large in diameter may be difficult to deliver while a device that is too long may interfere with the operation of the valve (e.g. interfere with the valve, interfere with blood flow, etc.).

[0075] Accordingly, some implanted devices such as but not limited to a leadless cardiac pacemaker (LCP) may be configured to include a rechargeable battery that provides the power needed by the LCP for a limited period of time. Because the rechargeable battery can be recharged in situ, the rechargeable battery can be smaller because it does not have to store sufficient energy to last the entire expected lifetime of the device. Rather, the rechargeable battery only needs to store sufficient energy to power the LCP for a period of time that corresponds to a reasonable recharging schedule. For example, a LCP with a rechargeable battery may undergo a recharging procedure on a daily basis, a weekly basis, a monthly basis, a by-yearly basis, a yearly basis, or any desired schedule, with the recognition that relative size of the rechargeable battery is at least roughly proportional to the interval between rechargings. For example, a relatively small rechargeable battery will take up less space within the LCP but will require more frequent recharging. A relatively large rechargeable battery will take up more space within the LCP but will require less frequent recharging as the larger rechargeable battery can store relatively more chemical energy. In some cases, the battery size may be roughly inversely proportional to the frequency of the impinging energy that is captured and used to recharge the rechargeable battery.

[0076] In some cases, an implanted device with a rechargeable battery may be implanted within a patient. In the case of an LCP with a rechargeable battery, the LCP may be implanted within a chamber of the patient's heart. The patient may periodically undergo a recharging procedure in which energy from outside of the patient may be transmitted to the LCP (or other implanted device) within the patient. In some cases, the LCP or other implanted device may include an antenna or other structure that is configured to receive the transmitted energy and the received energy may be used to

at least partially recharge the rechargeable battery. It will be appreciated that at least partially recharging the rechargeable battery may, for example, mean recharging the rechargeable battery to capacity. It may mean recharging the rechargeable battery to a charge level that is less than capacity. For example, recharging the rechargeable battery may mean recharging to a charge level that is about 50 percent (%) of capacity, about 60% of capacity, about 70% of capacity, about 80% of capacity, or about 90% of capacity.

[0077] FIG. 3 provides a highly schematic illustration of a patient 300 having an implantable device 302 implanted within the patient 300. While the implantable device 302 is shown as being in or near the patient's chest, it will be appreciated that this is merely illustrative, as the implantable device 302, depending on functionality, may be implanted in other locations within the patient 300. A transmitter 304 is shown exterior to the patient 300. In some cases, the transmitter 304 may be configured to transmit electromagnetic (EM) radiative energy that is of a wavelength (or frequency, as wavelength and frequency are related by the numerical speed of light) and intensity that can safely pass into the patient 300 to the implantable device 302 without causing excessive tissue heating or other potentially damaging effects to the patient 300.

[0078] The transmitter 304 may take any of a variety of forms. For example, while shown schematically as a box in FIG. 3, the transmitter 304 may be sized and configured for the patient 300 to periodically wear about their neck on a lanyard, which would place the transmitter 304 proximate their chest, at about the same vertical and horizontal position as the implantable device 302 within the patient's chest. In some cases, for example, the transmitter 304 may be built into the back of a chair that the patient 300 would periodically sit in to recharge the implantable device 302. The chair could be in the patient's home, for a daily recharge, for example, or could be at a remote location such as a medical clinic, for a patient 300 having a longer recharge schedule. As another example, the transmitter 304 could be built into a bed such that the transmitter 304 could at least partially recharge the implantable device 302 each evening when the patient 300 sleeps. In some cases, the transmitter 304 could be configured to only transmit once per week, or once per month, for example, depending on the power requirements of the implantable device 302. In some cases, the transmitter 304 and the implantable device 302 may communicate with each other. When so provided, the implantable device 302 may report its current battery recharge level to the transmitter 304, and if the current battery recharge level is below a threshold, the transmitter 304 may transmit power to the implantable device 302.

[0079] It will be appreciated that the implantable device 302 may be configured to periodically receive EM energy at a wavelength and intensity that is safe for the patient 300 and that the implantable device 302 may use to recharge a rechargeable battery within the implantable device 302. The EM energy may be received at a rate that exceeds a rate at which power is being drawn from the rechargeable battery and consumed by various components within the implantable device 302.

[0080] FIG. 4 provides an illustrative but non-limiting example of at least some of the internal components within the implantable device 302. In some cases, the implantable device 302 includes a device housing 306. In some cases, the device housing 306 may include at least a portion thereof

that is formed of a material that is transparent or at least substantially transparent to the EM energy that is being transmitted from the transmitter 304 to the implantable device 302. In this, "substantially" transparent may be defined, for example, as allowing at least 70%, or at least 80%, at least 90%, or at least 95% of incident energy at a particular wavelength (or range of wavelengths) to pass through the material without being absorbed by the material or blocked by the material. For example, at least a portion of the device housing 306, or even all of the device housing 306, may be made of a material such as glass or a ceramic. To illustrate, perhaps a first portion 306a of the device housing 306, which overlays a receiving antenna 308, may be made of a material that is transparent or at least substantially transparent to the EM energy that is being transmitted from the transmitter 304 while a second portion 306b of the device housing 306, which does not overlay the receiving antenna 308, may be made of other materials such as but not limited to metals which could otherwise interfere with EM energy transmitted from the transmitter 304 reaching the receiving antenna 308. In some cases, both the first portion 306a and the second portion 306b may be made of a material that is transparent or at least substantially transparent to the EM energy that is being transmitted from the transmitter 304.

[0081] The receiving antenna 308 may be any of a variety of different types of antennas. In some cases, the receiving antenna 308 may be a planar antenna, which in some cases is then conformed to a non-planar surface. In some cases, a planar antenna may be an antenna that is printed or deposited onto a planar surface, or perhaps etched into a planar surface. In some instances, depending on how the receiving antenna 308 is incorporated into the implantable device 302, the receiving antenna 308 may be considered as being a three-dimensional analog of a planar antenna (e.g. conformed to a non-planar shape). Illustrative but non-limiting examples of planar antennas include path antennas, slot antennas, ring antennas, spiral antennas, bow-tie antennas, TSA (Vivaldi) antennas, LPDA antennas, leaky-wave antennas and quasi-yagi antennas. In some cases, the antenna may include a resonator structure that helps to make the antenna more efficient and/or to increase an effective electrical length of the antenna such that the antenna may be made physically smaller.

[0082] EM energy that is transmitted from the transmitter 304 may be captured by the receiving antenna 308 and provided to a circuitry 310. In some cases, the circuitry 310 may be configured to convert the received EM energy into a form that may be used to recharge a rechargeable battery 312. In some cases, the circuitry 310 may also provide other functionality to the implantable device 302. For example, if the implantable device 302 is an LCP, the circuitry 310 may, in addition to recharging the rechargeable battery 312, also provide sense functions, pace functions, or sense and pace functions. In some instances, the circuitry 310 only functions to recharge the rechargeable battery 312, and the implantable device 302 may include other circuitry (not shown) to provide whichever other functions are ascribed to the implantable device 302.

[0083] When considering the electromagnetic regions around a transmitting antenna, there are three categories; namely, (1) reactive near-field; (2) radiated near-field and (3) radiated far-field. "Inductive" charging systems operate in the reactive near-field region. In inductive power systems,

power is typically transferred over short distances by magnetic fields using inductive coupling between coils of wire, or by electric fields using capacitive coupling between electrodes. In radiative power systems (e.g. radiated near-field and radiated far-field), power is typically transmitted by beams of electromagnetic (EM) energy. Radiative power systems can often transport energy for longer distances, but the ability of a receiving antenna to capture sufficient energy can be challenging, particular for applications where the size of the receiving antenna is limited.

**[0084]** In some cases, the transmitter **304** and implantable medical device **302** may operate at or above about 400 MHz within the patient's body. When so provided, the system does not operate in the reactive near-field (as in inductive charging system), but rather operates in either the radiated near-field or radiated far-field regions (depending on the placement of the implanted device and band of usage). For example, when the EM energy is transmitted at 400 MHz, the system is in the radiated near-field region and at 2.45 GHz the system is in the radiated far-field region. In some cases, the present system may operate at a frequency that is between, for example, about 400 MHz and 3 GHz. In some cases, more than one frequency within this range may be used simultaneously and/or sequentially. In some cases, multiple implanted devices may be simultaneously or sequentially charged using both the radiated near-field and radiated far-field regions.

**[0085]** The rechargeable battery **312** may be any type of rechargeable battery **312**, and may take a three dimensional shape that facilitates incorporation of the rechargeable battery **312** into the device housing **304**. In some cases, the rechargeable battery **312** may instead be a supercapacitor. As will be appreciated, in some cases the device housing **304** may have a cylindrical or substantially cylindrical shape, in which case a rechargeable battery **312** having a cylindrical or annular profile, such as a button battery or an elongated (in height) battery having a substantially cylindrical shape, may be useful. It is recognized that there are possible tradeoffs in rechargeable battery shape and dimensions relative to performance, so these issues should be considered in designing the rechargeable battery **312** for a particular use. While FIG. 4 schematically shows a single rechargeable battery **312**, in some cases there may be two, three or more distinct rechargeable batteries **312**, each electrically coupled with the circuitry **310**. For example, in some cases there may be performance advantages in having multiple rechargeable batteries **312**. In some instances, there may be packaging advantages to having multiple (and smaller) rechargeable batteries **312**.

**[0086]** FIG. 5 provides a schematic view of an IMD **320** that may be configured to be implanted within a patient such as the patient **300** (FIG. 3). The illustrative IMD **320** includes a housing **322** that is substantially transparent to EM energy such as radiative EM energy along at least part of its length. For example, in some cases, a first portion **322a** of the housing **322** may be substantially transparent to radiative EM energy while a second portion **322b** of the housing **320** may be less transparent to radiative EM energy. In some cases, the second portion **322b** of the housing **320** may also be substantially transparent to radiative EM energy. In some cases, at least the first portion **322a** of the housing **320** may be ceramic or glass. Circuitry **310** may be disposed within the housing **320**. In some cases, as described with respect to FIG. 4, the circuitry **310** may be mono-

functional, meaning its only function is for recharging, or the circuitry **310** may be multi-functional, meaning that the circuitry **310** has additional functionality beyond recharging.

**[0087]** In some cases, a first electrode **324** and a second electrode **326** may be exposed external to the housing **320** and may be operably coupled to the circuitry **310**. While two electrodes are illustrated, it will be appreciated that in some instances the IMD **320** may include three, four or more distinct electrodes. Depending on the intended functionality of the IMD **320**, the first electrode **324** and the second electrode **326**, in combination, may be used for sensing and/or pacing the patient's heart. In some instances, for example, the IMD **320** may be a leadless cardiac pacemaker (LCP), an implantable monitoring device or an implantable sensor. In some cases, the first electrode **324** and the second electrode **326** may, in combination, be used for communicating with other implanted devices and/or with external devices. In some cases, communication with other implanted devices may include conductive communication, but this is not required. Rechargeable battery **312** may be disposed within the housing **320** and may be configured to power the IMD **320**, including the circuitry **310**.

**[0088]** Receiving antenna **308** may be disposed within the housing **320** and may be configured to receive transmitted radiative EM energy through the housing **320**, such as through the first portion **322a** of the housing **320** that is substantially transparent to radiative EM energy. The circuitry **310** may be operably coupled with the receiving antenna **308** and the rechargeable battery **312**. In some cases, the circuitry **310** may be configured to charge the rechargeable battery **312** using the radiative EM energy received by the receiving antenna **308**. In some cases, the receiving antenna **308** may be configured to receive sufficient radiative EM energy from a wavelength band of radiative EM energy transmitted from outside the patient **300** (FIG. 3) to recharge the rechargeable battery **312** at a rate faster than the rechargeable battery **312** is depleted by powering the IMD **320** when the wavelength band of radiative EM energy is transmitted at an intensity that does not cause heat damage to the patient **300**. In some cases, the housing **320** has a substantially cylindrical profile and the receiving antenna **308** includes a planar antenna that has been conformed to the substantially cylindrical profile of an inner surface of an inner cavity defined by the housing **320**.

**[0089]** FIG. 6 provides a schematic view of an IMD **340** that may be configured to be implanted within a patient such as the patient **300** (FIG. 3). The illustrative IMD **340** includes a housing **342** that may be configured for transcatheter deployment. In some cases, this means that the housing **342** has overall dimensions that enable the IMD **340** to fit within a catheter or similar device for delivering the IMD **340** via a vascular approach. In some cases, the housing **342** may have an overall length of perhaps about five centimeters or less, or perhaps about three centimeters or less, and/or an overall width of perhaps about 2 centimeters or less, or perhaps about 1 centimeter or less. In some cases, for example, the housing **342** may also be substantially transparent to EM energy such as radiative EM energy along at least part of its length. For example, in some cases, a first portion **342a** of the housing **342** may be substantially transparent to radiative EM energy while a second portion **342b** of the housing **342** may be less transparent to radiative EM energy. In some cases, the second portion **342b** of the housing **342** may also be substantially transparent to radia-

tive EM energy. In some cases, at least the first portion 342a of the housing 342 may be ceramic or glass. In some cases, the housing 342 (or portions thereof) may be a ceramic housing, a glass housing or a polymeric housing.

[0090] While the illustrative IMD 320 (FIG. 5) included a single circuitry 310, which could be mono-functional or multi-functional, in some cases the IMD 340 (FIG. 6) includes charging circuitry 344 and therapeutic circuitry 346. In some cases, the charging circuitry 344 and the therapeutic circuitry 346 may be located on distinct circuit boards or be manifested within distinct integrated circuits (ICs). In some cases, the charging circuitry 344 and the therapeutic circuitry 346, while shown as distinct elements, may be combined within a single IC or on a single circuit board. The charging circuitry 344 may be operably coupled with the receiving antenna 308 and the rechargeable battery 312, and may be configured to use the radiative EM energy received by the receiving antenna 308 to charge the rechargeable battery 312.

[0091] In some cases, the IMD 340 may include a secondary battery 348 that is disposed within the housing 342 and that is operably coupled to the therapeutic circuitry 346. In some cases, the secondary battery 348 may function as a backup battery to the rechargeable battery 312. In some instances, the secondary battery 348 may also be a rechargeable battery and thus may also be operably coupled with the charging circuitry 344. In some cases, the secondary battery 348 may be a non-rechargeable battery.

[0092] In some cases, the therapeutic circuitry 346 may be operatively coupled to the first electrode 324 and the second electrode 326. While two electrodes are illustrated, it will be appreciated that in some instances the IMD 340 may include three, four or more distinct electrodes. In some instances, the therapeutic circuitry 346 may be configured to sense one or more signals via the electrodes 324, 326 (or additional electrodes) and/or to stimulate tissue via the electrodes 324, 326. In some cases, the therapeutic circuitry 346 may pace, or stimulate tissue, at least partly in response to the one or more sensed signals. In some cases, the first electrode 324 and the second electrode 326 may, in combination, be used for communicating with other implanted devices and/or with external devices. In some cases, communication with other implanted devices may include conductive communication, but this is not required in all cases.

[0093] FIG. 7 is a schematic cross-sectional side view of an illustrative LCP 400 having a rechargeable battery. The illustrative LCP 400 has a housing 402 that is formed of a ceramic material, a glass material or perhaps a polymeric material. It will be appreciated, therefore, that the housing 402 is at least substantially transparent to radiative EM energy that is incident upon the LCP 400. The housing 402 defines an interior volume 404 that houses a variety of different components, including but not limited to circuitry 406 and a rechargeable battery 408. In some cases the circuitry 406 may be limited to recharging the rechargeable battery 408. In some instances, the circuitry 406 may also have additional functionality such as sensing and/or pacing, although in some cases the LCP 400 may include additional circuitry for additional functionality. In some cases, the circuitry 406 is operably coupled with a first electrode 420 and one or more other electrodes (not shown).

[0094] A receiving antenna 410 is operably coupled to the circuitry 406. In some cases, as illustrated, the housing 402 itself may form at least one or more layers of the receiving

antenna 410. In some cases, the receiving antenna 410 includes an outer metal layer 412 and an inner metal layer 414, connected by a via 416 extending through an aperture 418 in the housing 402 wall. While the outer metal layer 412 and the inner metal layer 414 are schematically illustrated as simple layers, it will be appreciated that in some cases the outer metal layer 412 and/or the inner metal layer 414 may include patterns within the metal. The outer metal layer 412 and/or the inner metal layer 414 may, for example, be formed by etching away portions of a base metal layer. In some cases, the outer metal layer 412 and/or the inner metal layer 414 may be formed via a deposition process. In some cases, the ceramic or other material forming the housing 402 may function as a dielectric layer between the outer metal layer 412 and the inner metal layer 414.

[0095] In some cases, a biocompatible polymeric layer 422 may cover the outer metal layer 412. The biocompatible polymeric layer 422 may, for example, be formed of a polyimide or Parylene. In some cases, depending on the exact material used to form the housing 402, and whether the exact material is biocompatible, a polymeric coating (not shown) may cover essentially all of the outer surface of the housing 402 in order to improve biocompatibility. In some instances, particularly if the housing 402 is formed of a material having any porosity, a polymeric covering may help to reduce porosity.

[0096] In some cases, and as shown in FIG. 7, the receiving antenna 410 may be built right into the housing 402 of the LCP 400. In some cases, however, the receiving antenna may be formed in or on a first structure that can subsequently be inserted into or advanced over a device housing. For example, FIG. 8 shows a sleeve insert that can be inserted into a device housing, and FIG. 9 shows an outer sleeve that can be disposed over a device housing.

[0097] More specifically, FIG. 8 shows a sleeve insert 500 that is configured to be insertable into a device housing 502. The device housing 502 includes an elongated cavity 504 that is configured to accommodate the sleeve insert 500 therein. While the elongated cavity 504 is illustrated as generally being an entire interior space of the device housing 502, it will be appreciated that in some cases the interior of the device housing 502 may be divided into compartments, and the elongated cavity 504 may be one of those compartments. The sleeve insert 500 may be considered as having an outer surface 506 and an inner surface 508. A receiving antenna 510 may be built into the sleeve insert 500. In some cases, the receiving antenna 510 includes a first metal pattern 512 that is formed on the outer surface 506 and a second metal pattern 514 that is formed on the inner surface 508. The material forming the sleeve insert 500 may, for example, include a dielectric layer and may itself form part of the receiving antenna 510. In some cases, the first metal pattern 512 and the second metal layer 514 may form an antenna with a resonator. The device housing 502 may be at least substantially transparent to radiative EM energy to allow the radiative EM energy to reach the receiving antenna 510.

[0098] FIG. 9 shows an outer sleeve 516 that is configured to fit over a device housing 518. In some cases, the outer sleeve 516 may be considered as having an outer surface 520 and an inner surface 522. The outer sleeve 516 may include a receiving antenna 524 that is built into the outer sleeve 516. In some cases, for example, the receiving antenna 524 may include a first metal pattern 526 that is formed on the

outer surface 520 and a second metal pattern 528 that is formed on the inner surface 522. The material forming the outer sleeve 516 may, for example, include a dielectric layer and may itself form part of the receiving antenna 524. In some cases, the first metal pattern 526 and the second metal layer 528 may form an antenna with a resonator. In this embodiment, the device housing 518 need not be substantially transparent to radiative EM energy since the radiative EM energy need not travel through the device housing 518 to reach the receiving antenna 524.

[0099] FIGS. 10 through 12 provide illustrative but non-limiting examples of receiving antenna patterns. It will be appreciated that these patterns (and others) may be built directly into a device housing, as shown for example in the LCP 400 of FIG. 7. In some cases, these patterns (and others) may be used in building a sleeve insert such as the sleeve insert 500 (FIG. 8). In some instances, these patterns (and others) may be used in building an outer sleeve such as the outer sleeve 516. FIGS. 10-12 illustrate a cylindrical form 600 that may, for example, represent a sleeve insert or an outer sleeve, or perhaps a device housing. While shown as a cylinder, it will be appreciated that the cylindrical form 600 may take any desired shape, size or configuration.

[0100] The cylindrical form 600 includes an outer surface 602. In FIG. 10, a first receiving antenna 604 and a second receiving antenna 606 are shown disposed relative to the outer surface 602. The receiving antenna 604 and the receiving antenna 606 may, for example, be formed entirely on the outer surface 602. In some cases, the receiving antenna 604 and the receiving antenna 606 may be formed with components on the outer surface 602 and components interior to the cylindrical form 600 (e.g. antenna with a resonator).

[0101] While two receiving antennae 604 and 606 are shown, the device may include any number of receiving antennae. FIG. 11, for example, is a schematic cross-sectional view showing a total of four receiving antennae 608, 610, 612, 614, with each receiving antenna constructed with a first metal pattern 616, 618, 620, 622 disposed on the outer surface 602 and a corresponding second metal pattern 624, 626, 628, 630 disposed on an inner surface 632, with vias 634, 636, 638, 640 extending between the first metal pattern 616, 618, 620, 622 and the second metal pattern 624, 626, 628, 630.

[0102] FIG. 12 illustrates a receiving antenna 642 that is laid out in a helical or spiral pattern relative to the outer surface 602. The receiving antenna 642 may, for example, be formed entirely on the outer surface 602. In some cases, the receiving antenna 524 may be formed with components on the outer surface 602 and components interior to the cylindrical form 600. While indicated as a single helical receiving antenna 642, in some cases the receiving antenna 642 may instead have distinct segments, such as a segment 642a, a segment 642b and a segment 642c.

[0103] It will be appreciated that in some cases, an antenna such as a receiving antenna may have a null such as a spatial null and/or a frequency null. A spatial null indicates a direction from which no signal or very little signal may be received. A frequency null indicates a particular frequency or range of frequencies for which no signal or very little signal may be received. In some cases, if a device such as an implantable device includes two or more receiving antennae, it will be appreciated that each antenna may have a spatial null. There may be advantages to laying out the two or more

receiving antenna such that the spatial nulls do not align in space. This may be particularly useful in an implantable device, in which the exact implanted orientation of the device is uncertain and/or may change with time. In many cases, particularly if the implantable device is planted in or on the heart, the device is constant moving. FIGS. 13 and 14 provide several illustrative but non-limiting examples of how antennae may be laid out in order to intentionally miss-align their respective spatial nulls.

[0104] In FIG. 13, a first receiving antenna 650 is laid out relative to the outer surface 602 of the cylindrical form 600, oriented at a first angle relative to a longitudinal axis 648. A second receiving antenna 652 is laid out relative to the outer surface 602, oriented at a second angle relative to the longitudinal axis 648, with the first angle being different from the second angle. In FIG. 14, a first receiving antenna 654 is laid out relative to the outer surface 602, oriented roughly perpendicular to the longitudinal axis 648. A second receiving antenna 656 is laid out relative to the outer surface 602, oriented roughly parallel with the longitudinal axis 648. It will be appreciated that one or more of the receiving antennae 650, 652, 654, 656 may, for example, be formed entirely on the outer surface 602. In some cases, one or more of the receiving antennae 650, 652, 654, 656 may be formed with components on the outer surface 602 and components interior to the cylindrical form 600. It will also be appreciated that the angles shown in FIGS. 13 and 14 are merely illustrative.

[0105] It should be understood that this disclosure is, in many respects, only illustrative. Changes may be made in details, particularly in matters of shape, size, and arrangement of steps without exceeding the scope of the disclosure. This may include, to the extent that it is appropriate, the use of any of the features of one example embodiment being used in other embodiments.

What is claimed is:

1. An implantable medical device (IMD) configured to be implanted within a patient, the IMD comprising:
  - a housing configured for trans-catheter deployment;
  - a plurality of electrodes exposed external to the housing;
  - therapeutic circuitry disposed within the housing, the therapeutic circuitry operatively coupled to the plurality of electrodes and configured to sense one or more signals via one or more of the plurality of electrodes and/or to stimulate tissue via one or more of the plurality of electrodes;
  - a rechargeable power source disposed within the housing and configured to power the therapeutic circuitry;
  - a receiving antenna disposed relative to the housing and configured to receive transmitted radiative Electro-Magnetic (EM) energy through the patient's body; and
  - charging circuitry operably coupled with the receiving antenna and the rechargeable power source, the charging circuitry configured to use the radiative EM energy received via the receiving antenna to charge the rechargeable power source.
2. The IMD of claim 1, further comprising a secondary battery disposed within the housing and operatively coupled to the therapeutic circuitry, the secondary battery functioning as a backup battery to the rechargeable power source.
3. The IMD of claim 2, wherein the secondary battery is a non-rechargeable battery.
4. The IMD of claim 1, wherein the IMD comprises a leadless cardiac pacemaker (LCP).

5. The IMD of claim 1, wherein the housing is substantially transparent to radiative EM energy.

6. The IMD of claim 5, wherein the housing comprises a ceramic housing, a glass housing, or a polymeric housing.

7. The IMD of claim 5, wherein the receiving antenna comprises a first metal pattern formed on an outer surface of a sleeve insert and a second metal pattern formed on an inner surface of the sleeve insert, and the sleeve insert is configured to be inserted into an elongated cavity of the housing of the IMD.

8. The IMD of claim 1, wherein the receiving antenna comprises a first metal pattern formed on an outer surface of an outer sleeve and a second metal pattern formed on an inner surface of the outer sleeve, and the outer sleeve is configured to fit over and be secured relative to the housing of the IMD.

9. The IMD of claim 1, wherein the at least one of the plurality of electrodes forms part of the receiving antenna.

10. An implantable medical device (IMD) configured to be implanted within a patient, the IMD comprising:

a housing that is substantially transparent to radiative Electro-Magnetic (EM) energy along at least part of its length;

circuitry disposed within the housing;

a plurality of electrodes exposed external to the housing and operatively coupled to the circuitry;

a rechargeable power source disposed within the housing and configured to power the IMD including the circuitry;

a receiving antenna disposed within the housing and configured to receive transmitted radiative EM energy through the at least part of the housing that is substantially transparent to radiative EM energy; and

the circuitry operably coupled with the receiving antenna and the rechargeable power source, the circuitry configured to use the radiative EM energy received via the receiving antenna to charge the rechargeable power source.

11. The IMD of claim 10, wherein the IMD comprises a leadless cardiac pacemaker (LCP).

12. The IMD of claim 10, wherein the IMD comprises an implantable monitoring device.

13. The IMD of claim 10, wherein the IMD comprises an implantable sensor.

14. The IMD of claim 10, wherein the receiving antenna comprises a first receiving antenna having a first null and a second receiving antenna having a second null offset from the first null.

15. The IMD of claim 10, wherein the housing comprises ceramic.

16. The IMD of claim 10, wherein the housing comprises glass.

17. The IMD of claim 10, wherein the receiving antenna is configured to receive sufficient radiative EM energy from a wavelength band of radiative EM energy transmitted from outside the patient to recharge the rechargeable power source at a rate faster than the rechargeable power source is depleted by powering the IMD when the wavelength band of radiative EM energy is transmitted at an intensity that does not cause heat damage to the patient.

18. The IMD of claim 10, wherein at least a portion of the housing has a substantially cylindrical profile and the receiving antenna comprises a planar antenna conformed to the substantially cylindrical profile.

19. An implantable medical device (IMD) configured to be implanted within a patient, the IMD comprising:

a housing forming at least part of a receiving antenna, wherein the receiving antenna is configured to receive transmitted radiative Electro-Magnetic (EM) energy through the patient's body;

a plurality of electrodes exposed external to the housing; circuitry disposed within the housing, the circuitry operatively coupled to the plurality of electrodes and configured to sense one or more signals via one or more of the plurality of electrodes and/or to stimulate tissue via one or more of the plurality of electrodes;

a rechargeable power source disposed within the housing and configured to power the circuitry; and

charging circuitry operably coupled with the receiving antenna and the rechargeable power source, the charging circuitry configured to use the radiative EM energy received via the receiving antenna to charge the rechargeable power source.

20. The IMD of claim 19, wherein the housing forms one or more layers of the receiving antenna.

\* \* \* \* \*

专利名称(译)	带可充电电池的植入式医疗设备		
公开(公告)号	<a href="#">US20170281955A1</a>	公开(公告)日	2017-10-05
申请号	US15/475918	申请日	2017-03-31
[标]申请(专利权)人(译)	心脏起搏器股份公司		
申请(专利权)人(译)	心脏起搏器, INC.		
当前申请(专利权)人(译)	心脏起搏器, INC.		
[标]发明人	MAILE KEITH R KANE MICHAEL J LINDER WILLIAM J		
发明人	MAILE, KEITH R. KANE, MICHAEL J. LINDER, WILLIAM J.		
IPC分类号	A61N1/378 A61N1/05 A61B5/00 A61B5/042 A61N1/375 A61N1/37		
CPC分类号	A61N1/3787 A61N1/3756 A61N1/37 A61B2560/0219 A61B5/0422 A61N1/056 A61B5/686 A61N1/37205 A61N1/37229		
优先权	62/316158 2016-03-31 US		
外部链接	<a href="#">Espacenet</a> <a href="#">USPTO</a>		

摘要(译)

诸如无引线心脏起搏器的可植入医疗设备可包括可再充电电源。在一些情况下,系统可以包括植入设备,该设备包括接收天线和发射射频能量的外部发射器,该射频能量可以由接收天线捕获,然后被转换成可以用于对可再充电电源再充电的电能。因此,由于可再充电电源不必为植入装置的预期寿命维持足够的能量存储,因此可以使电源本身以及因此植入装置更小,同时仍满足装置寿命预期。

