



US 20160166169A1

(19) **United States**
(12) **Patent Application Publication**
Badower et al.

(10) **Pub. No.: US 2016/0166169 A1**
(43) **Pub. Date: Jun. 16, 2016**

(54) **SYSTEMS AND METHODS TO GATHER AND ANALYZE ELECTROENCEPHALOGRAPHIC DATA**

Publication Classification

(71) Applicant: **The Nielsen Company (US), LLC**, New York, NY (US)

(51) **Int. Cl.**
A61B 5/0476 (2006.01)
A61B 5/00 (2006.01)
A61B 5/04 (2006.01)

(72) Inventors: **Yakob Badower**, Berlin (DE);
Ramachandran Gurumoorthy, Berkeley, CA (US);
A. K. Pradeep, Berkeley, CA (US);
Robert T. Knight, Berkeley, CA (US)

(52) **U.S. Cl.**
CPC *A61B 5/0476* (2013.01); *A61B 5/04012* (2013.01); *A61B 5/6803* (2013.01)

(21) Appl. No.: **15/044,488**

(57) **ABSTRACT**

(22) Filed: **Feb. 16, 2016**

Example methods are disclosed herein that include obtaining electroencephalographic (EEG) data from a subject via a device comprising two or more independently adjustable bands, each of the bands having a plurality of electrodes to detect the electroencephalographic data from a brain of the subject, each band selectively rotatable relative to an adjacent band and each band selectively compressible to increase a force of the electrodes against a head of the subject. The example method also includes converting the EEG data into digital EEG signals and conditioning the digital EEG signals. In addition, the example method includes analyzing the digital EEG signals using one or more analysis protocols to determine a mental characteristic of the subject and transmitting the mental characteristic to an output device.

Related U.S. Application Data

(63) Continuation of application No. 13/730,212, filed on Dec. 28, 2012.

(60) Provisional application No. 61/684,640, filed on Aug. 17, 2012.

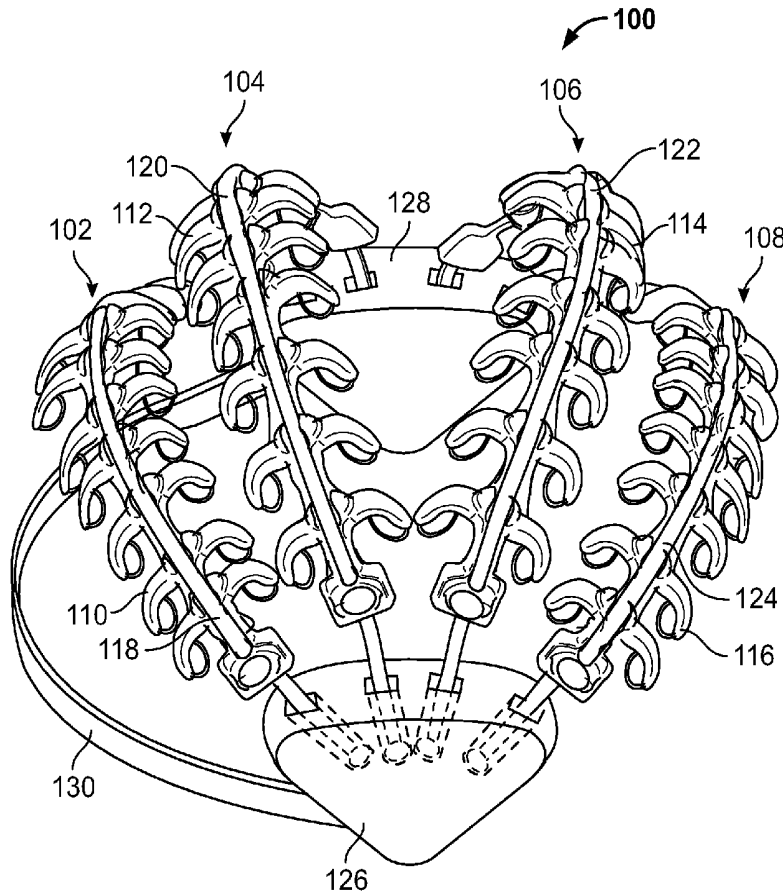

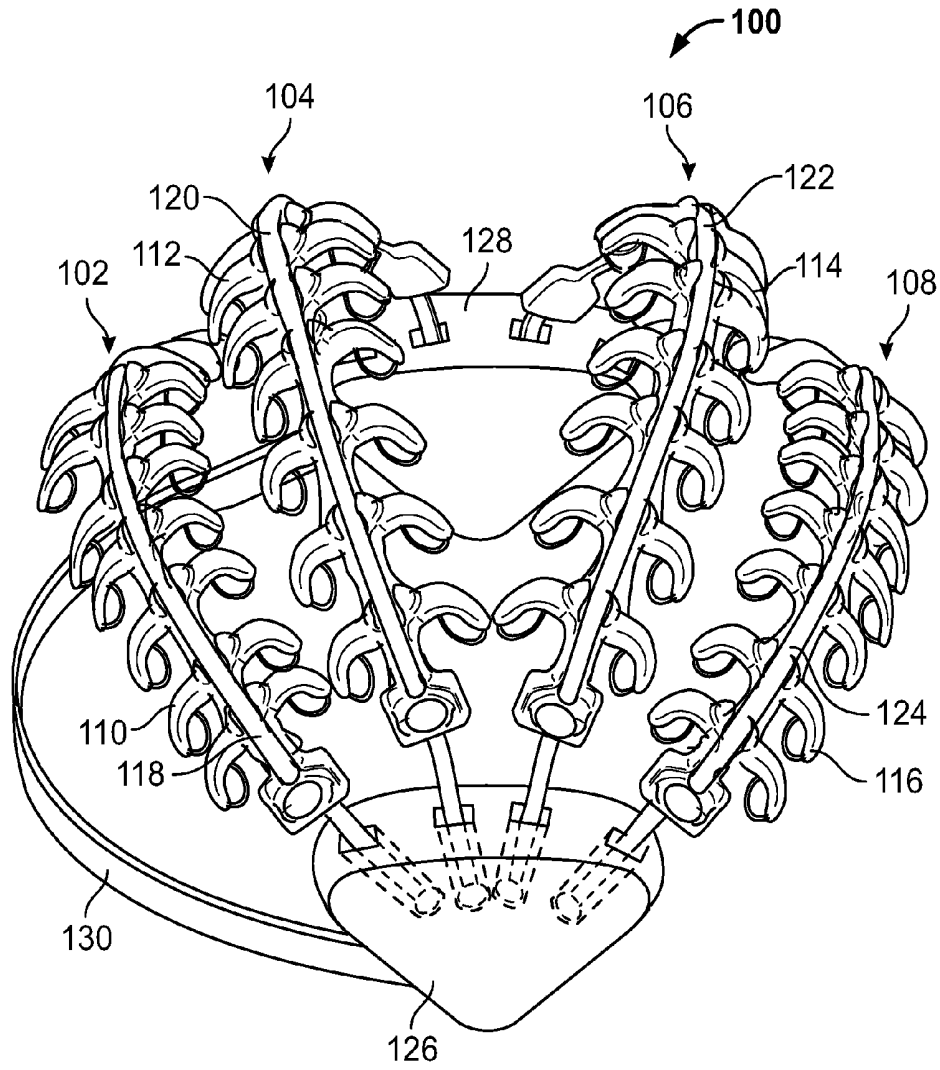

FIG. 1

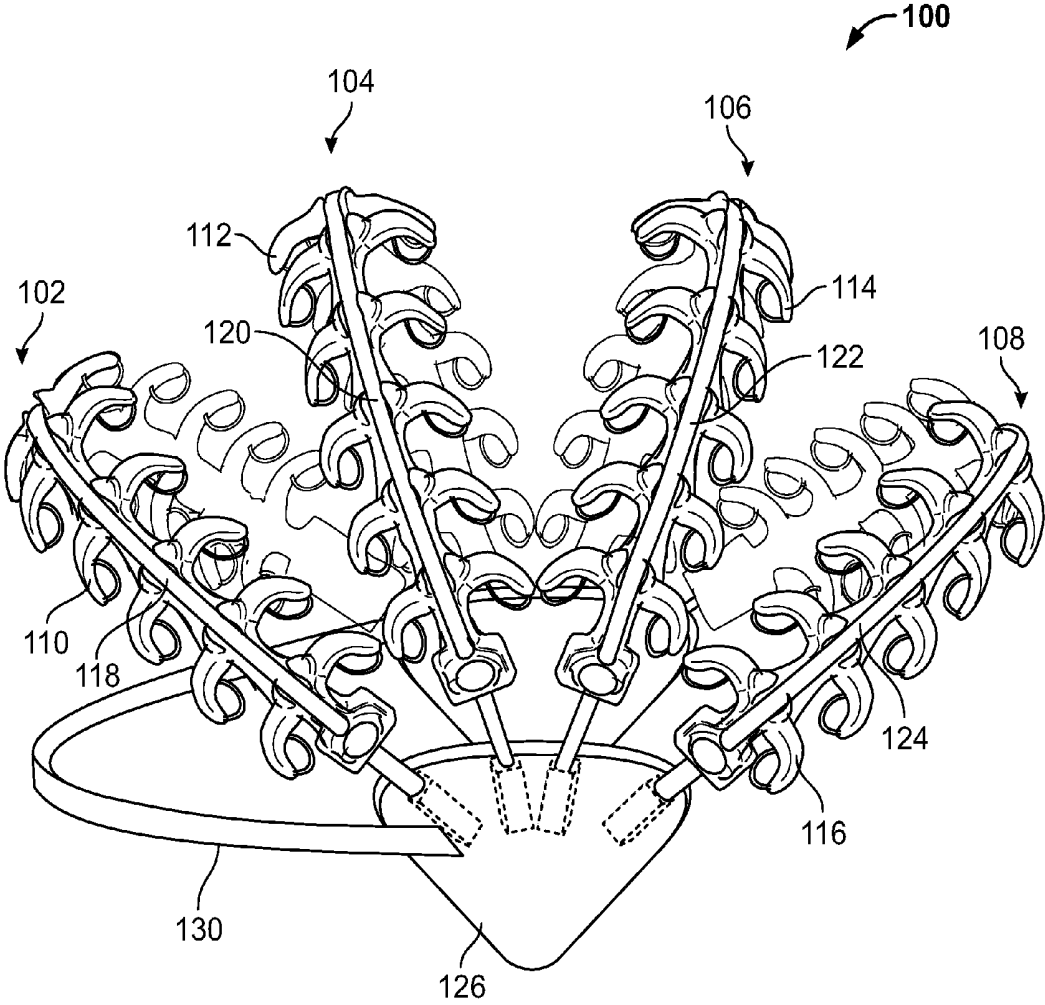

FIG. 2

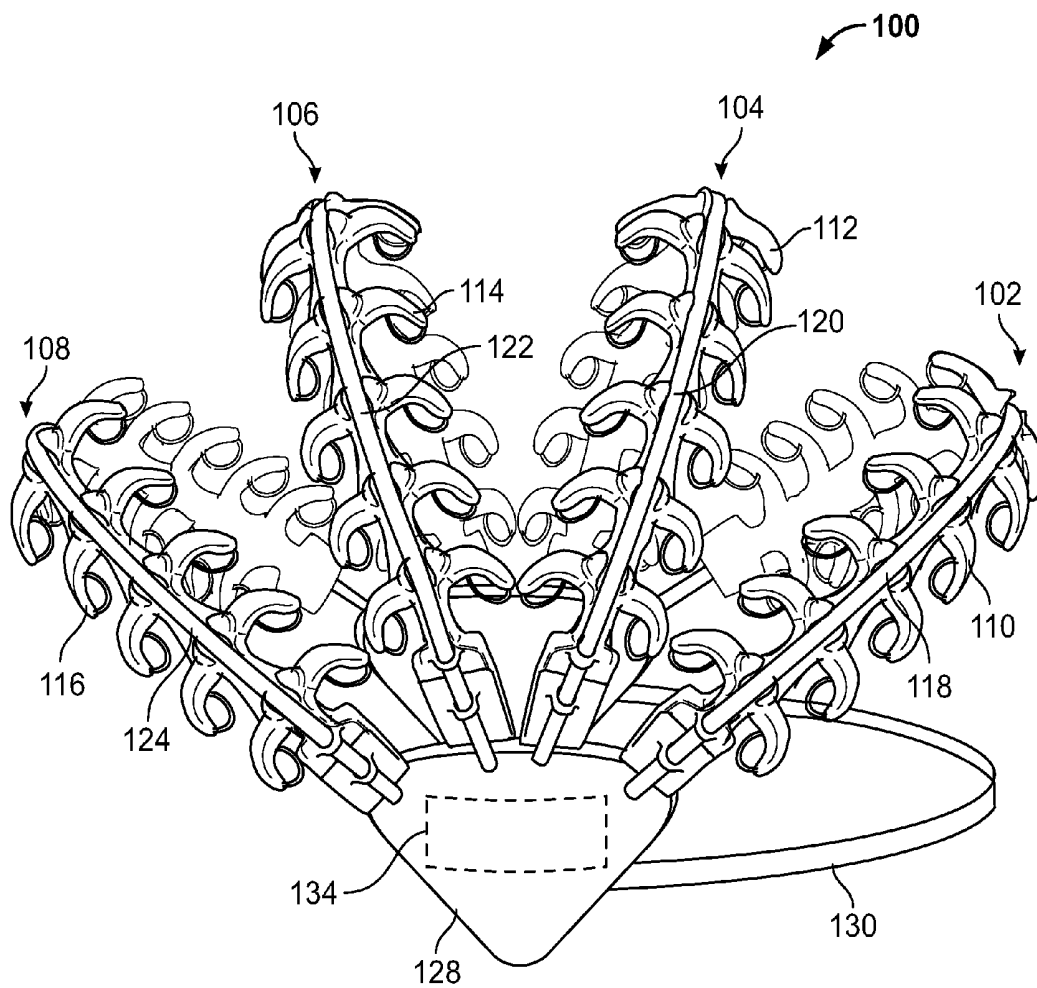

FIG. 3

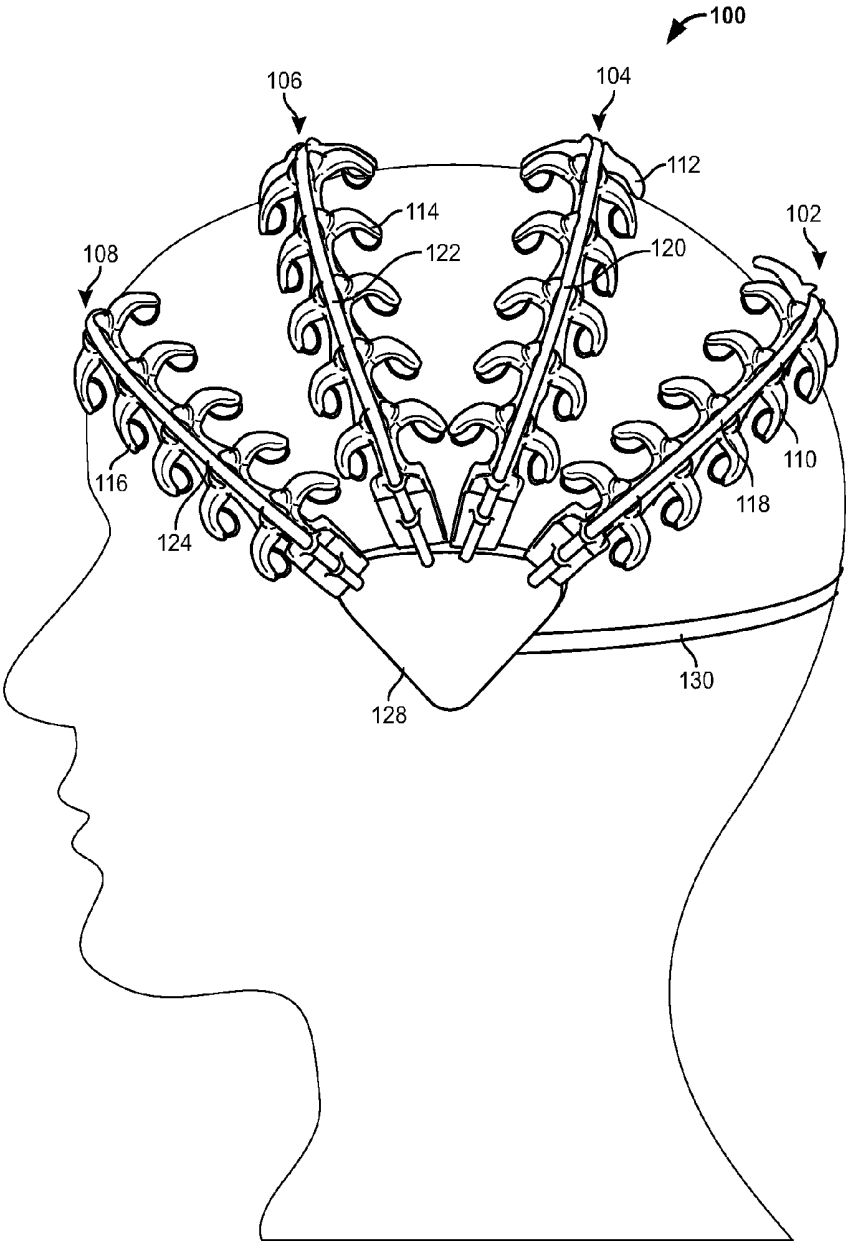

FIG. 4A

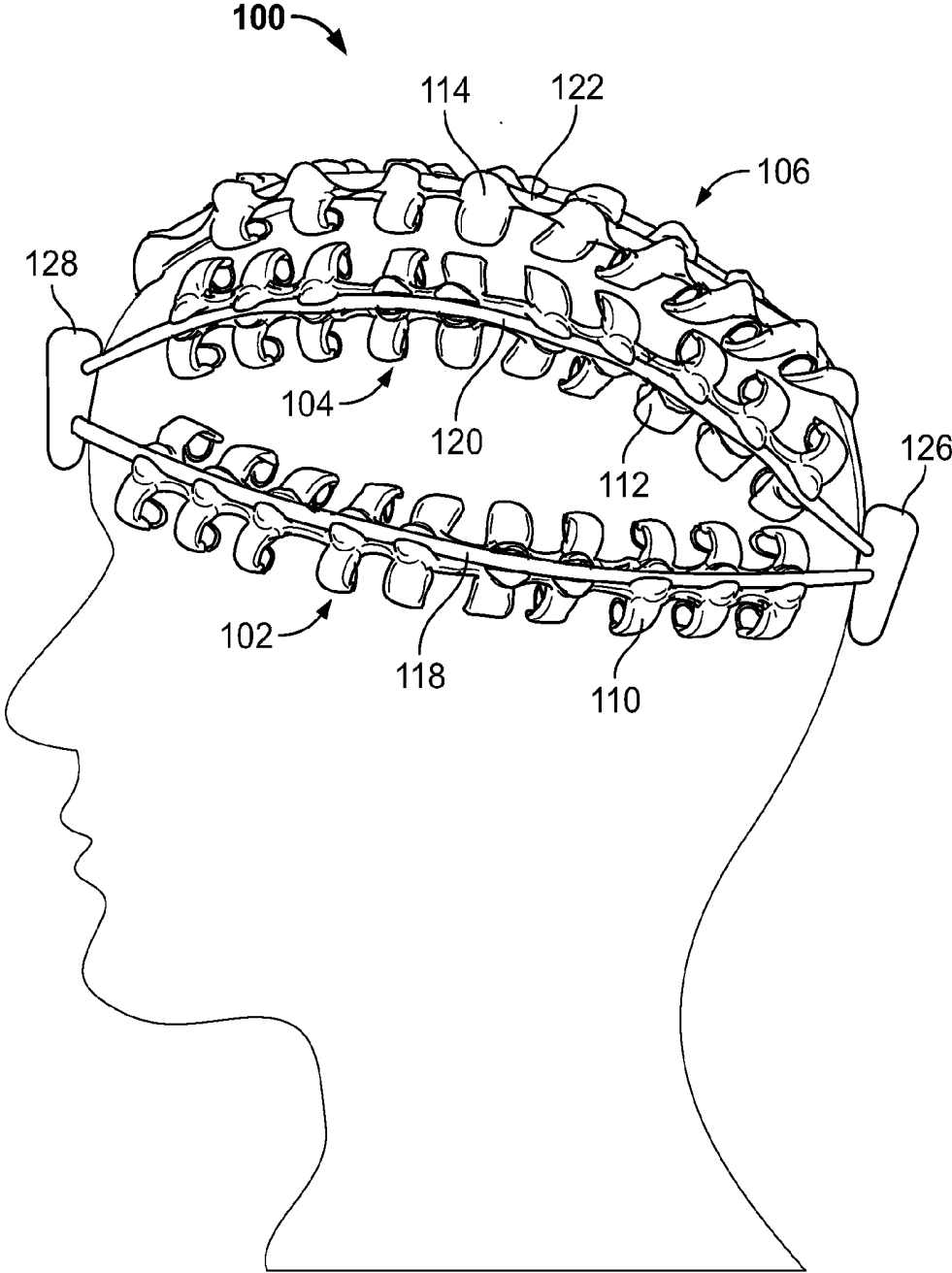

FIG. 4B

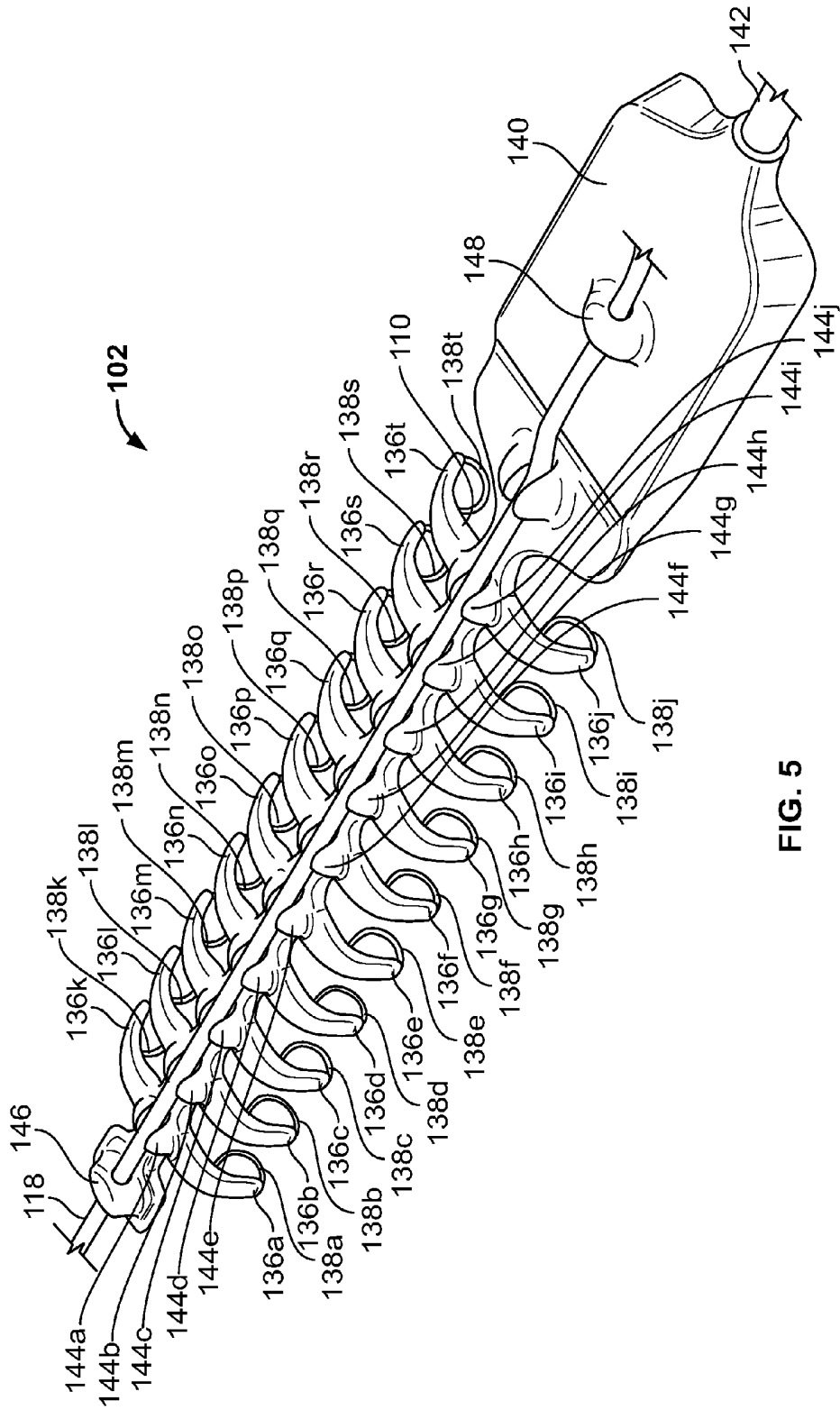

FIG. 5

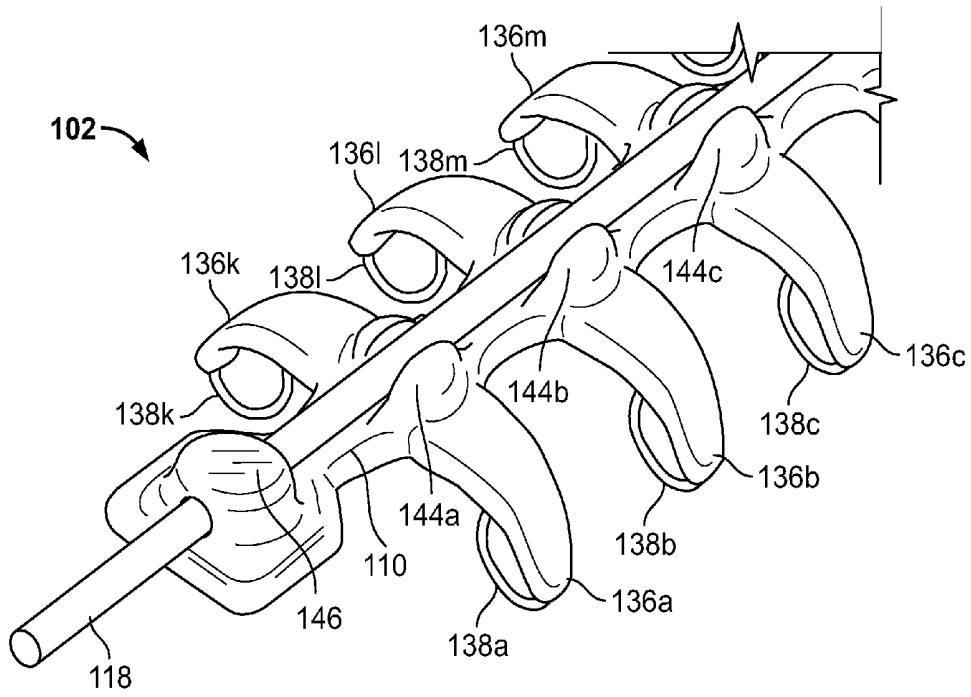

FIG. 6

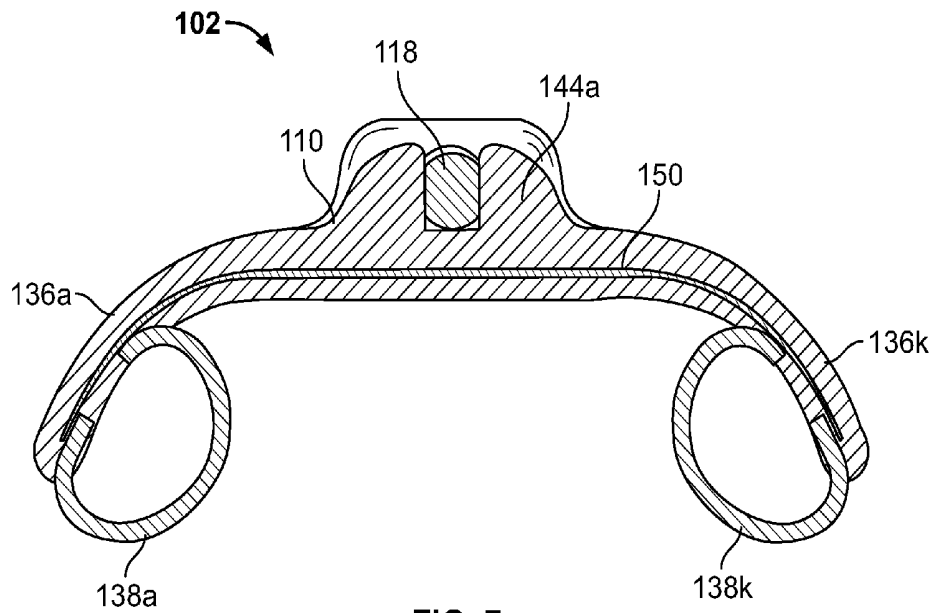

FIG. 7

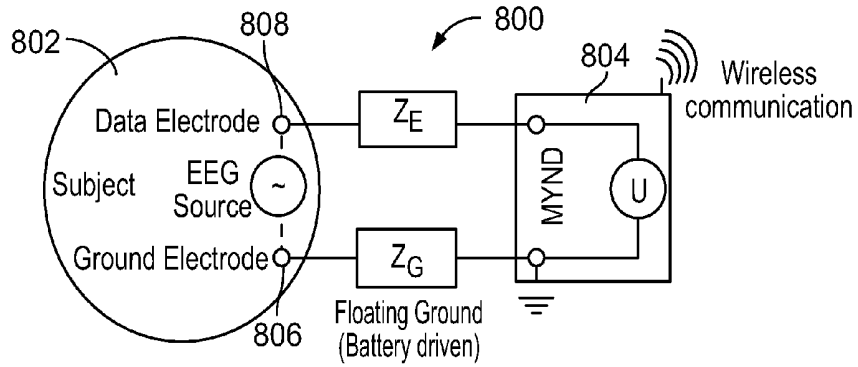

FIG. 8A

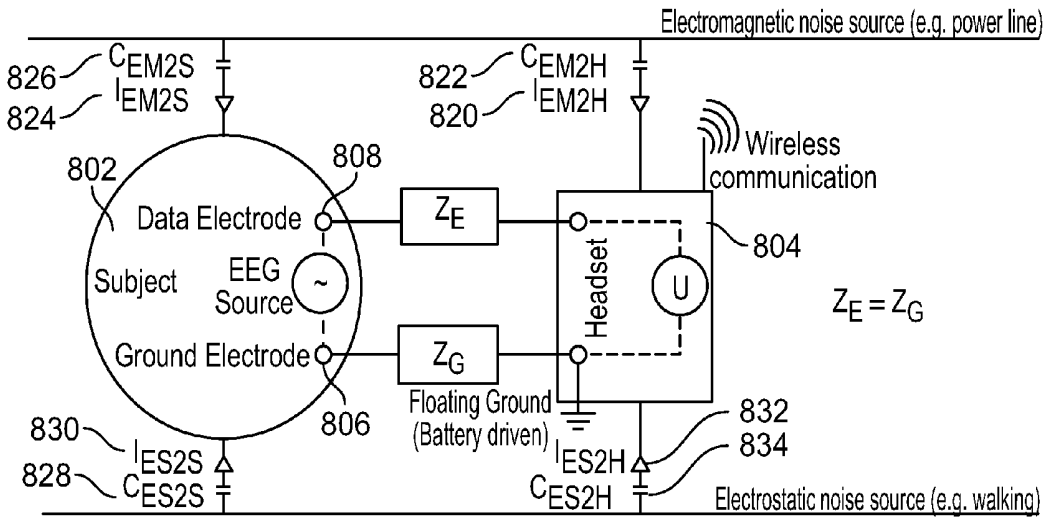

FIG. 8B

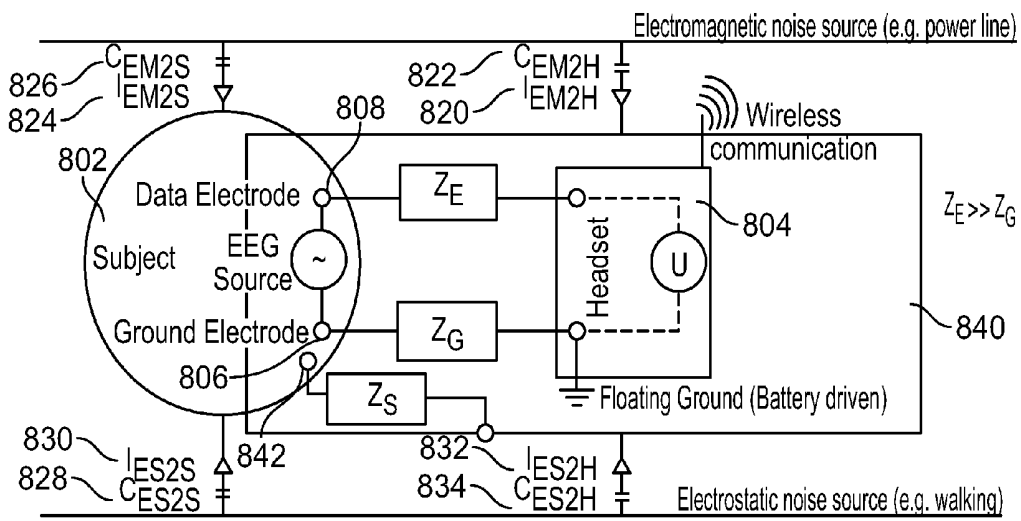

FIG. 8C

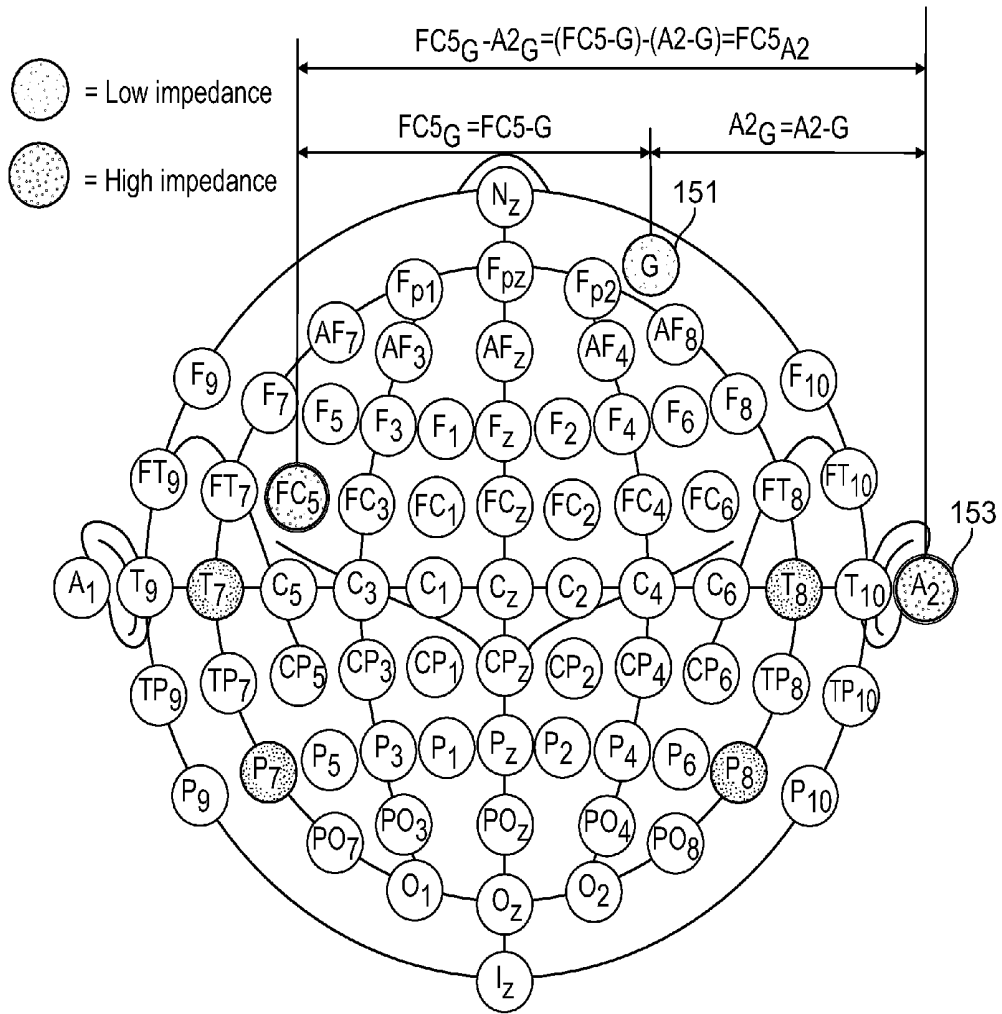

FIG. 9

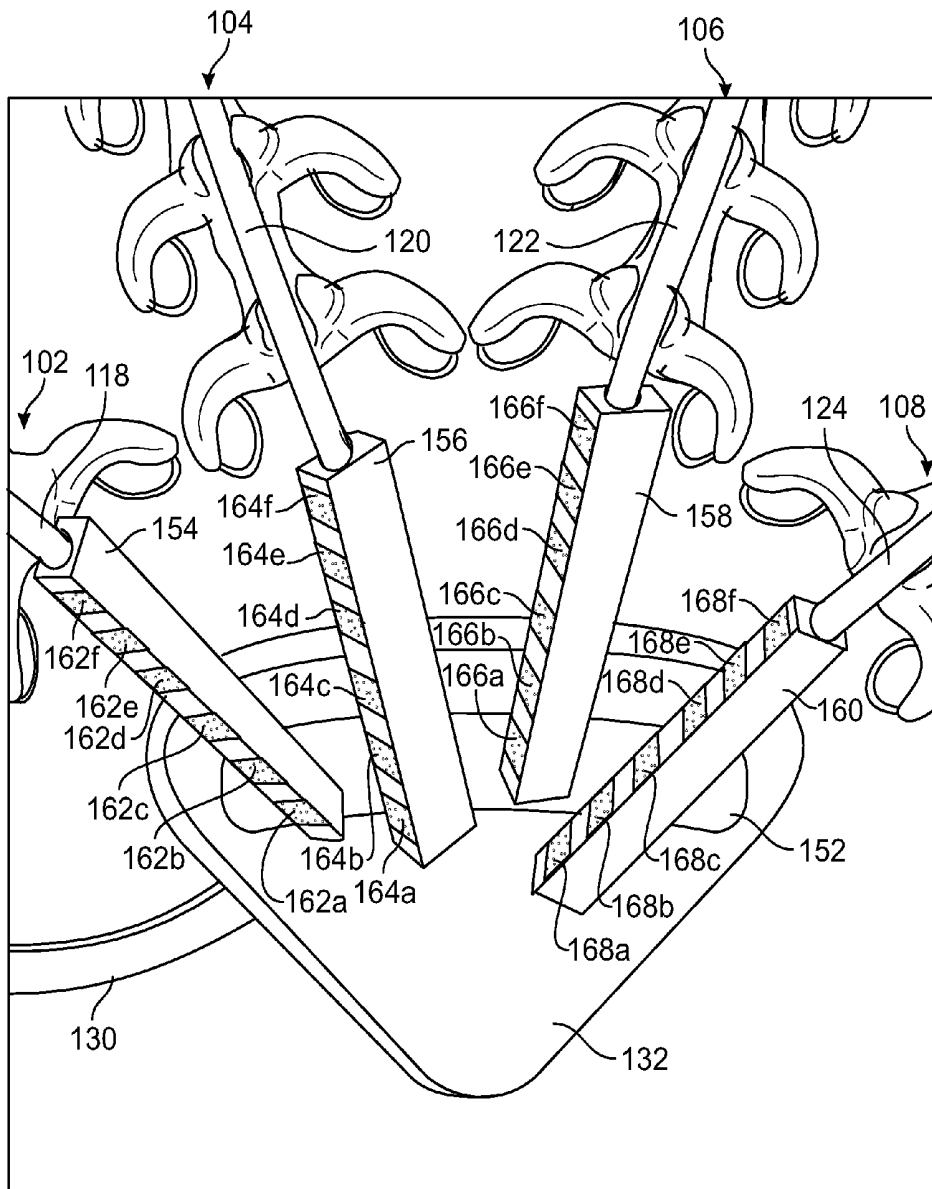

FIG. 10

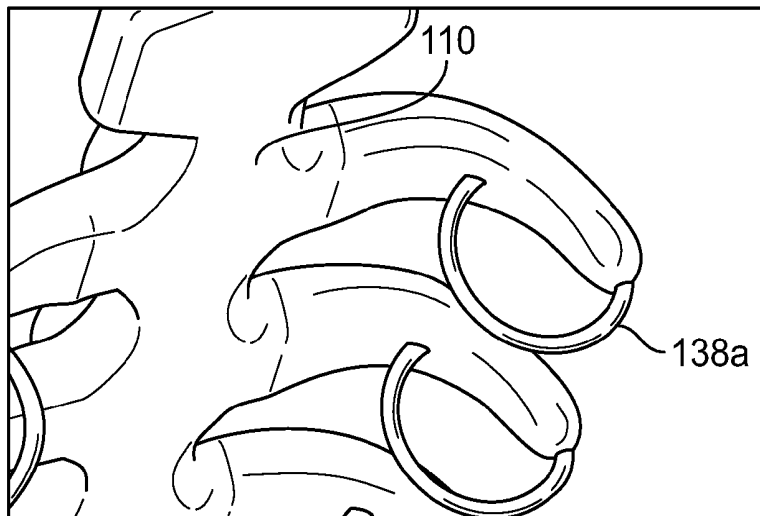

FIG. 11A

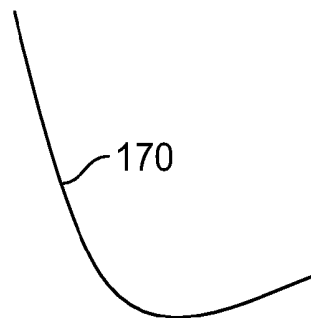

FIG. 11B

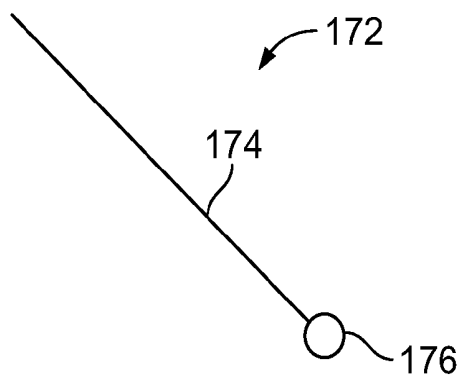

FIG. 11C

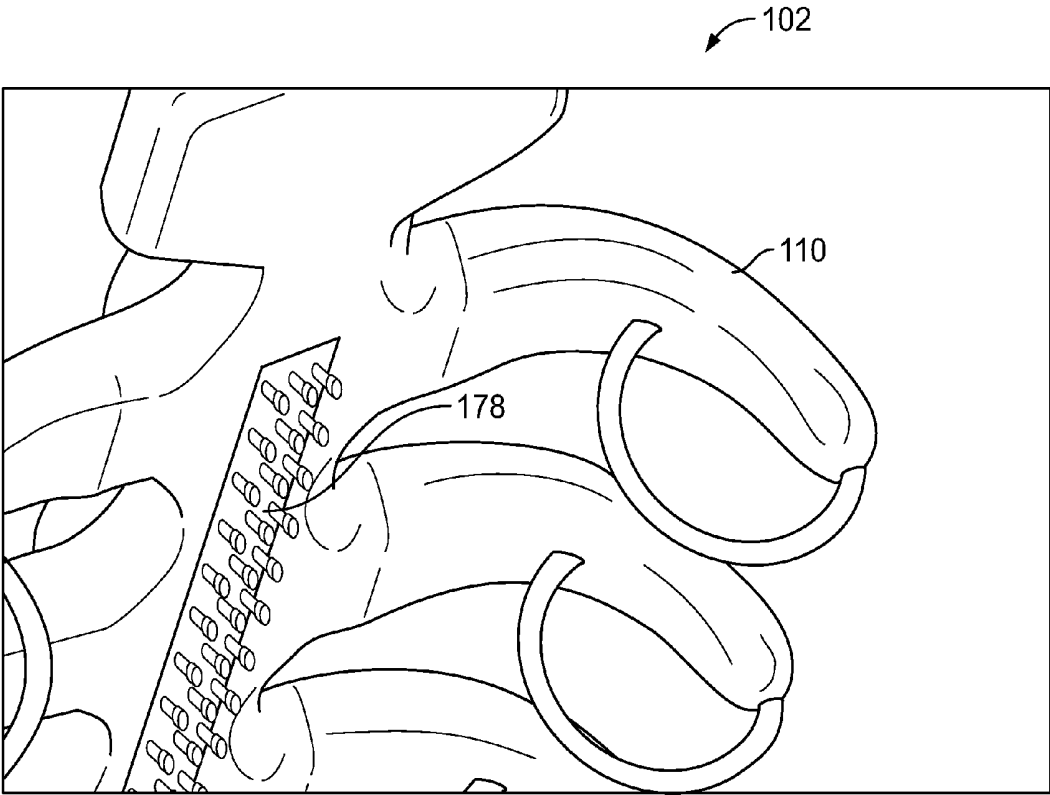

FIG. 11D

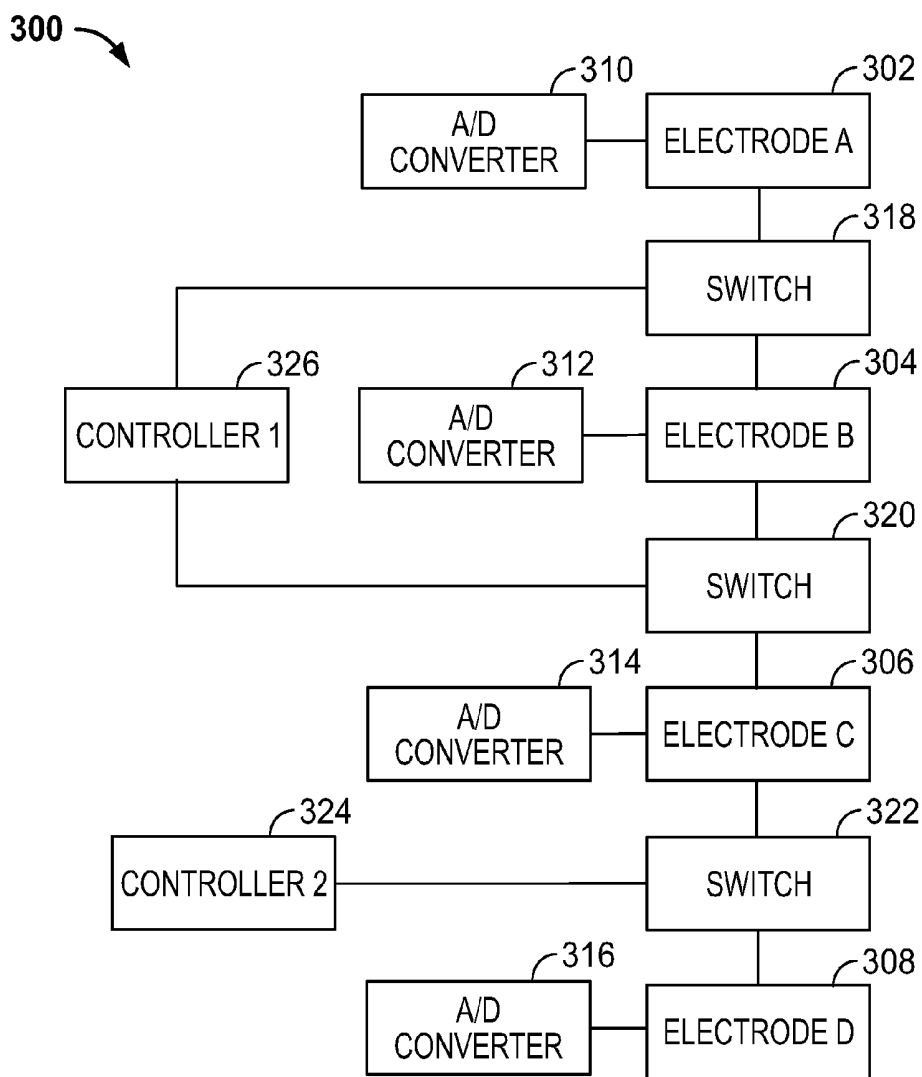

FIG. 12A

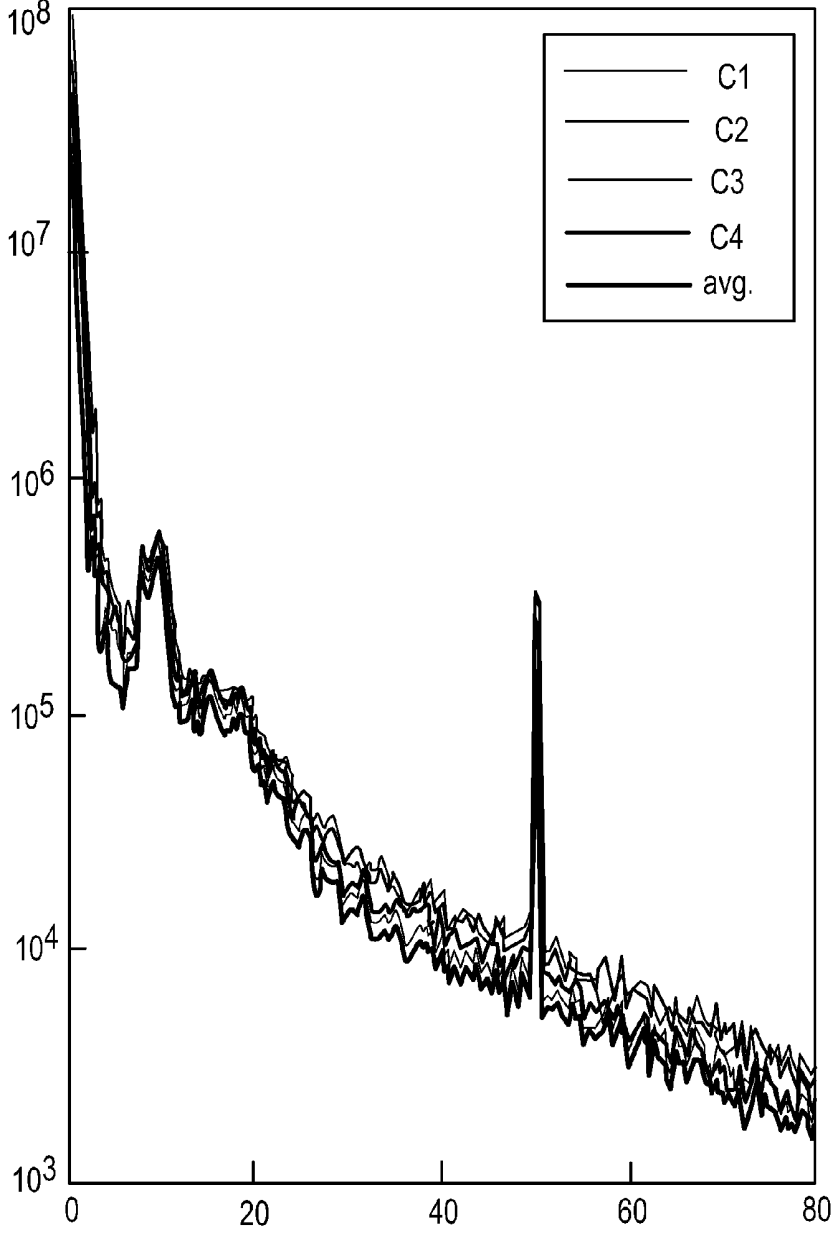

FIG. 12B

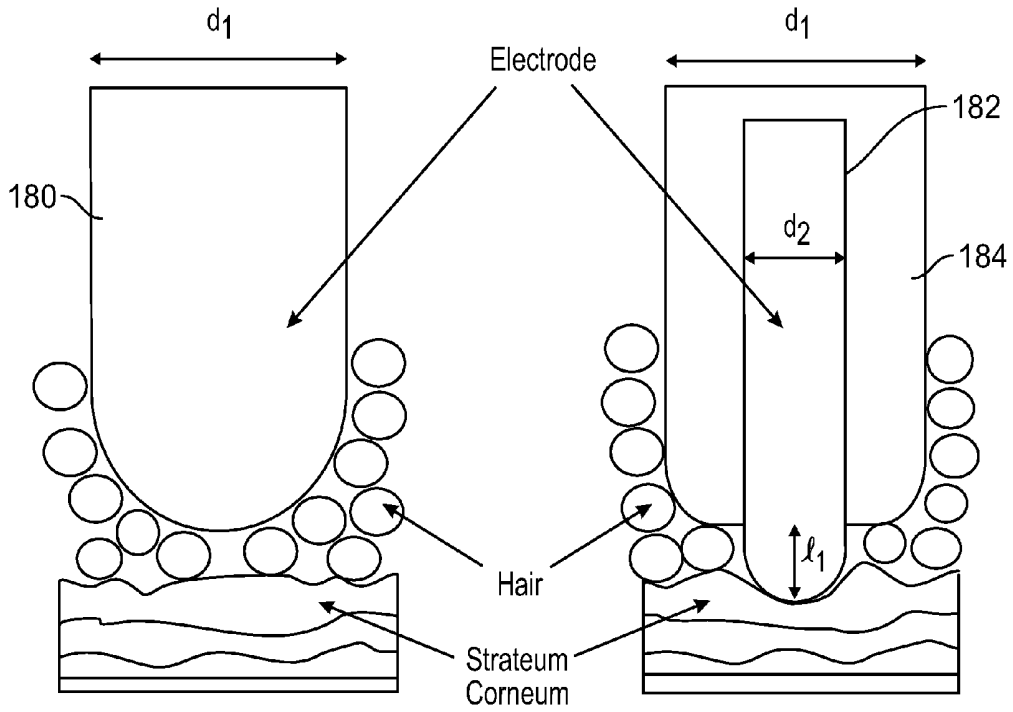

FIG. 13A

FIG. 13B

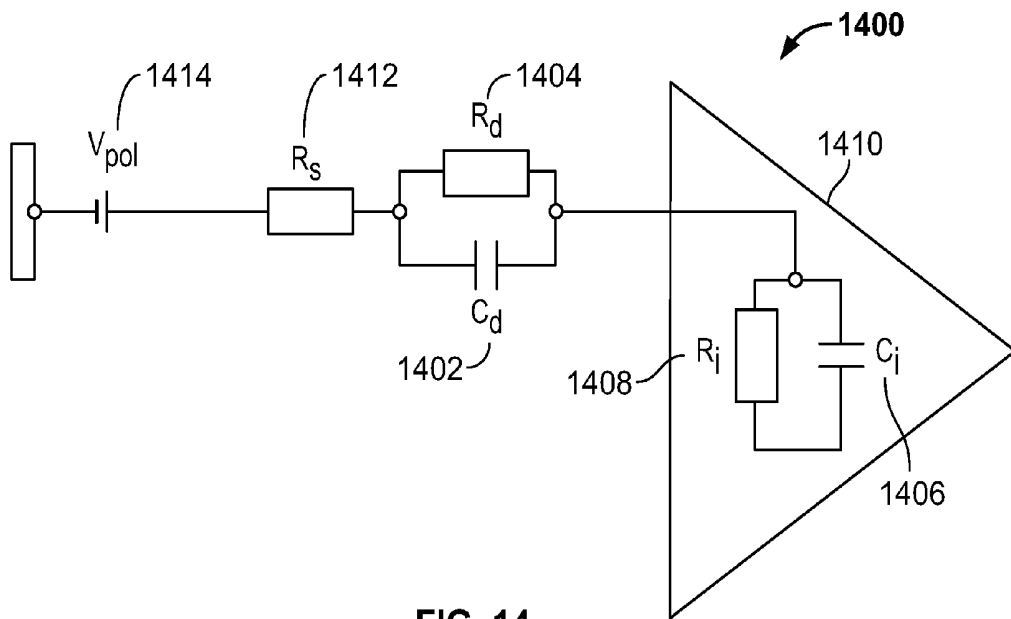

FIG. 14

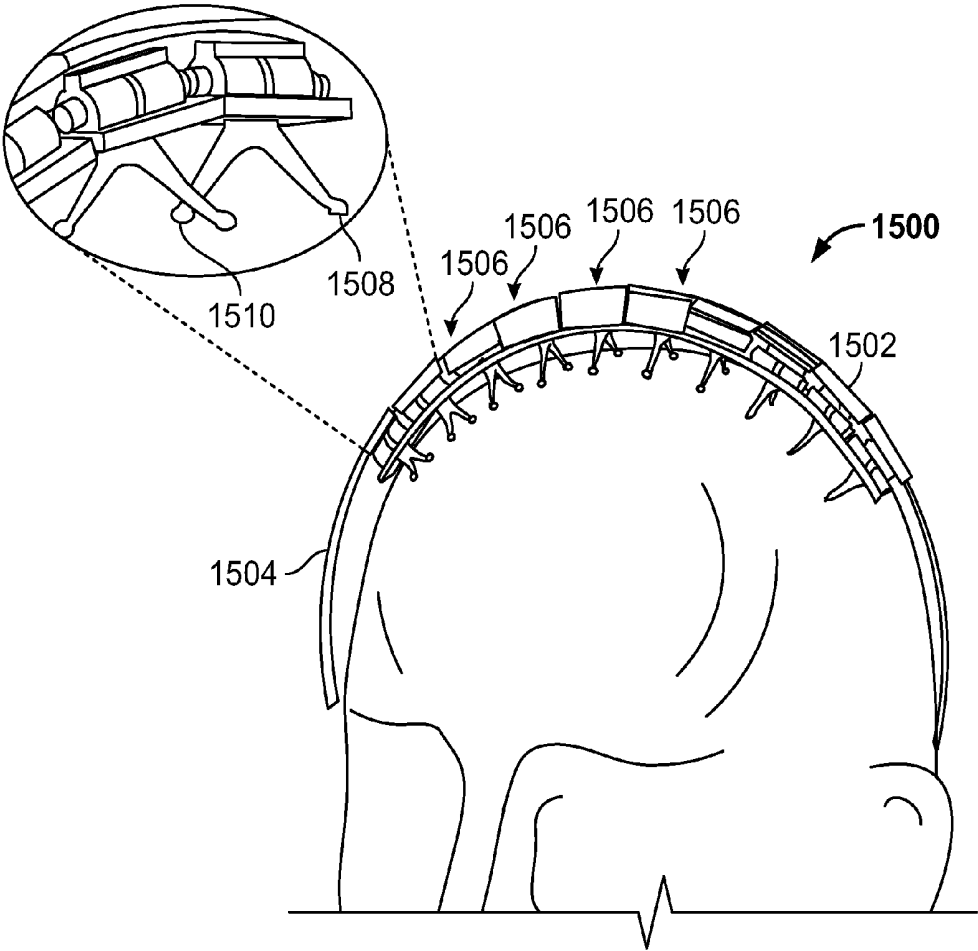

FIG. 15

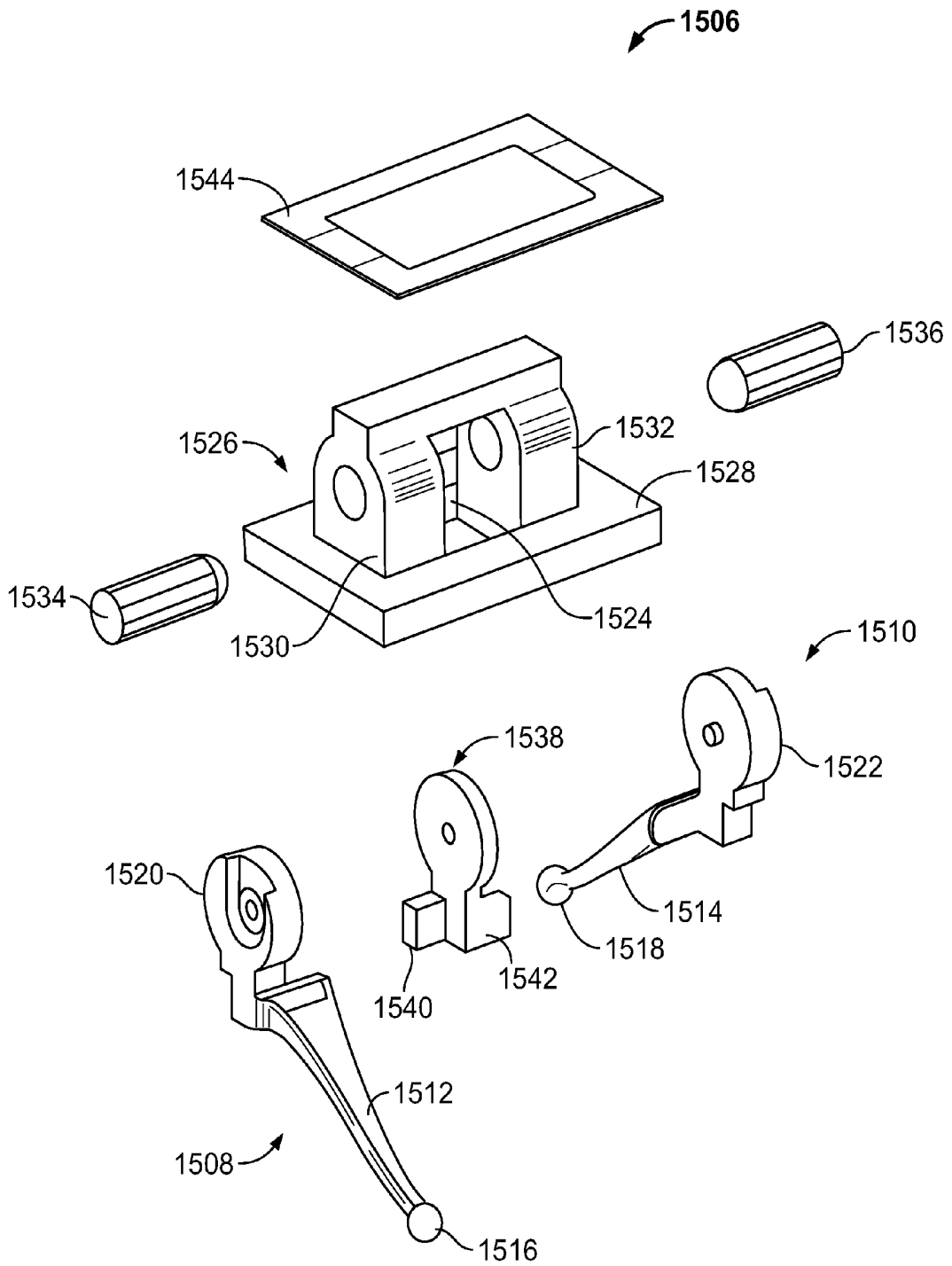

FIG. 16

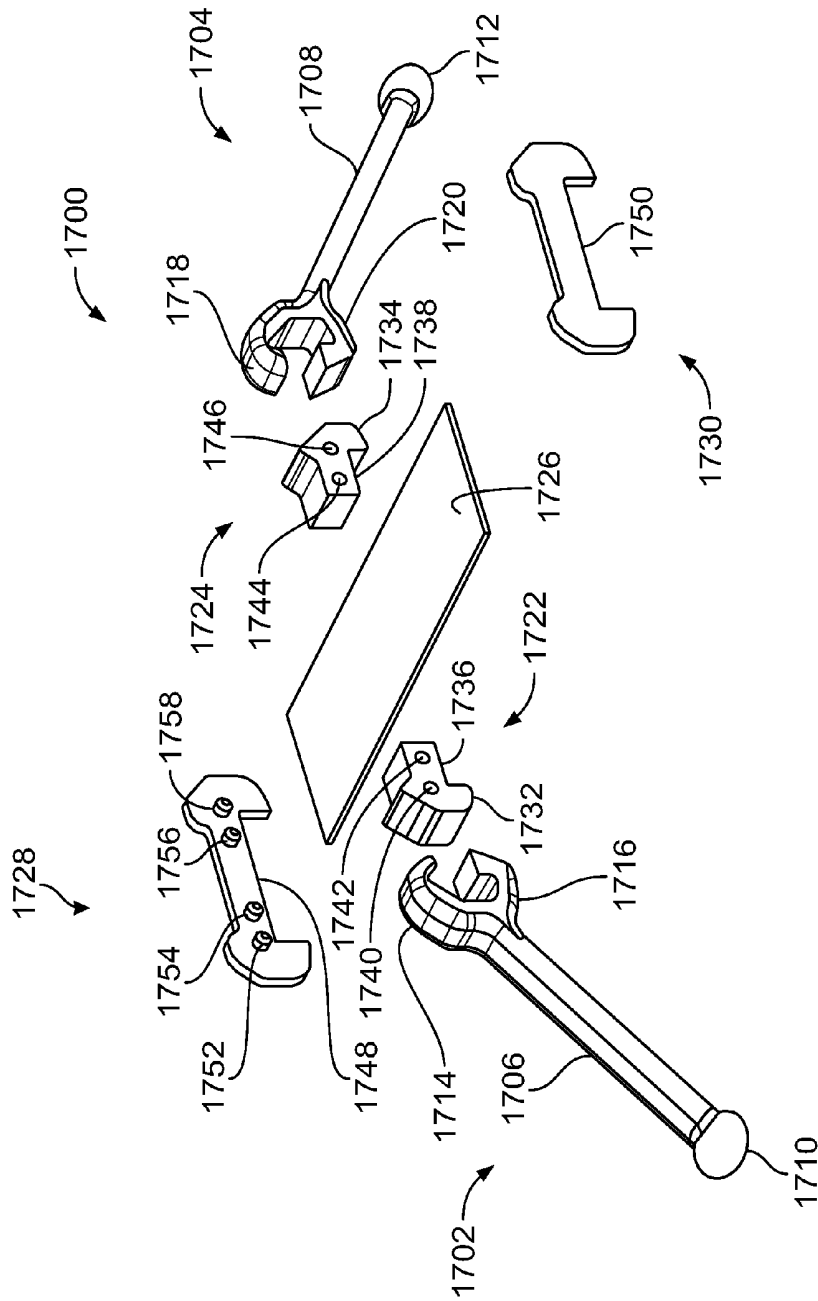

FIG. 17

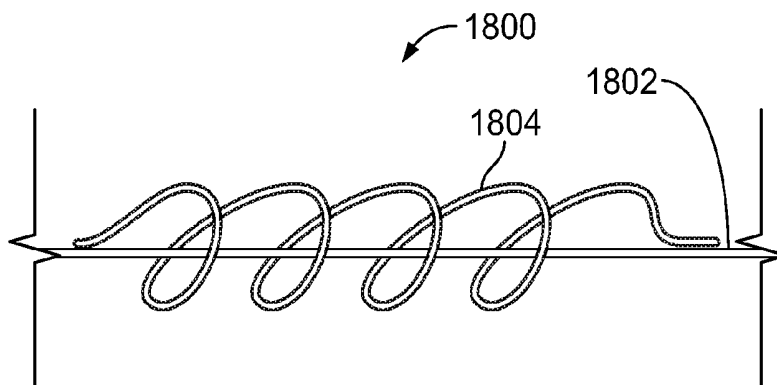

FIG. 18

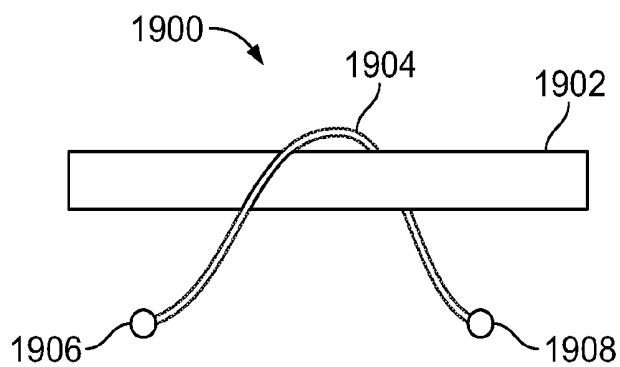

FIG. 19A

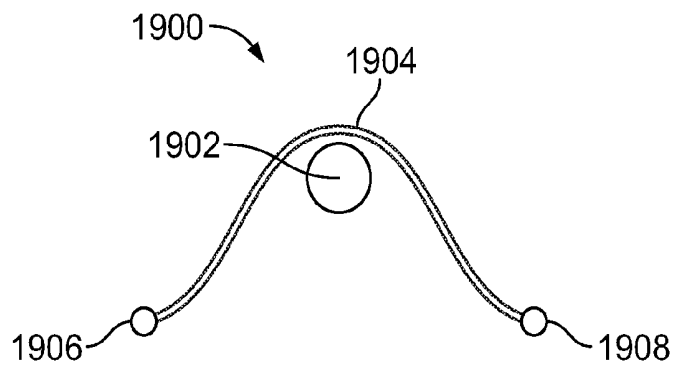

FIG. 19B

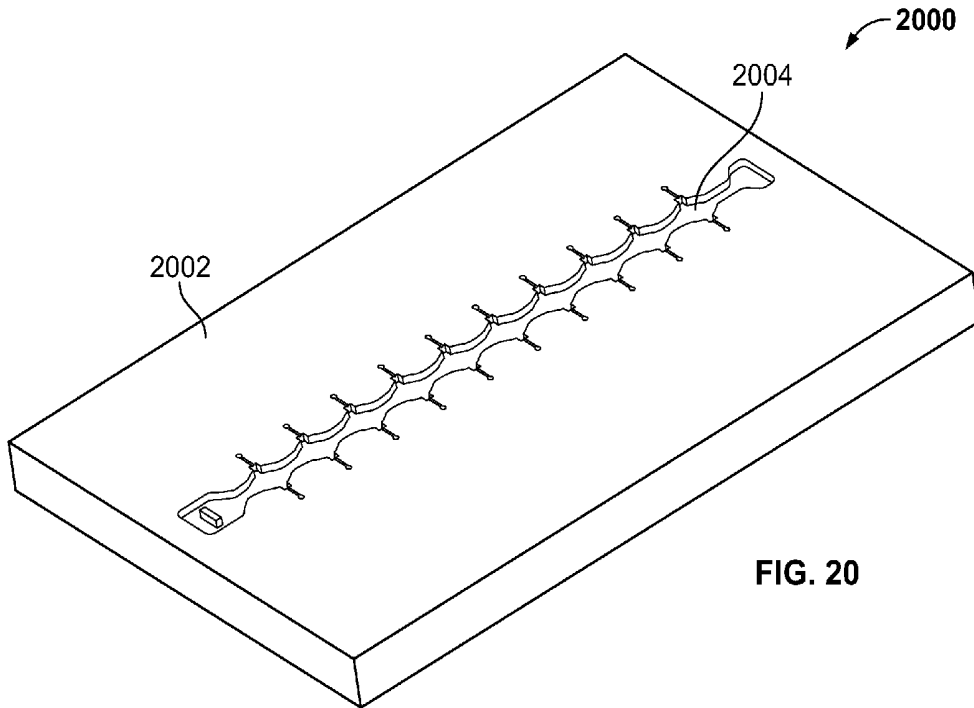

FIG. 20

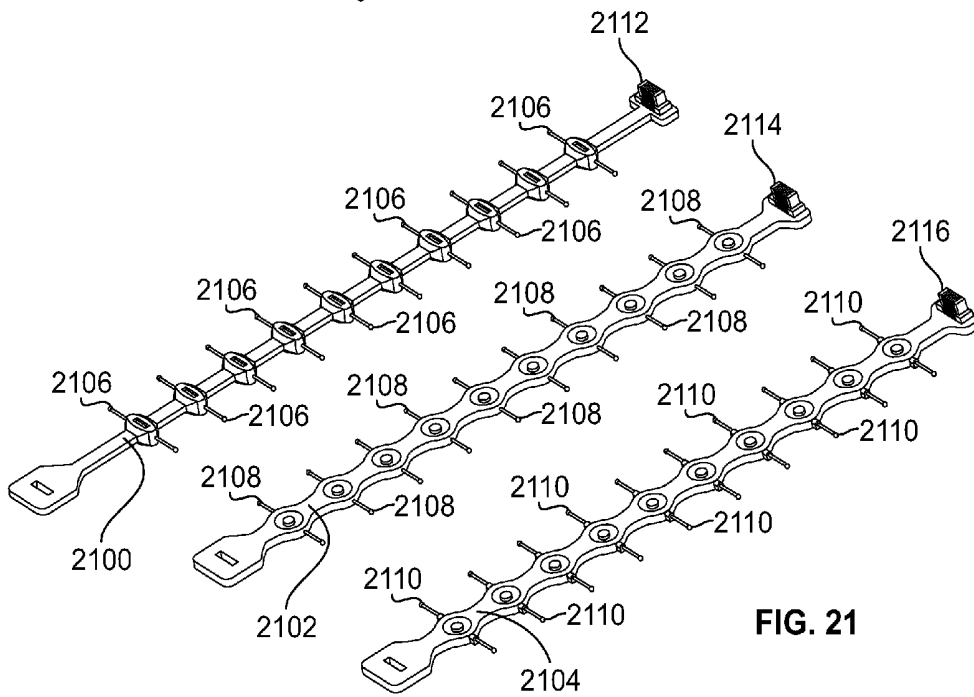

FIG. 21

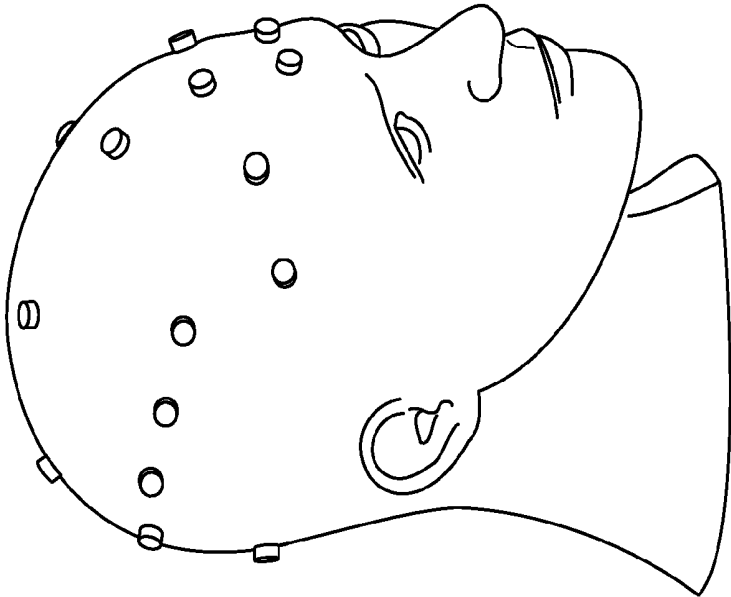

FIG. 22C

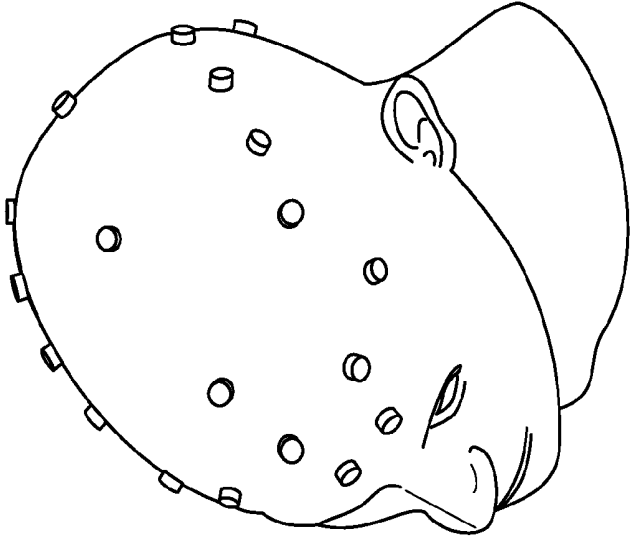

FIG. 22B

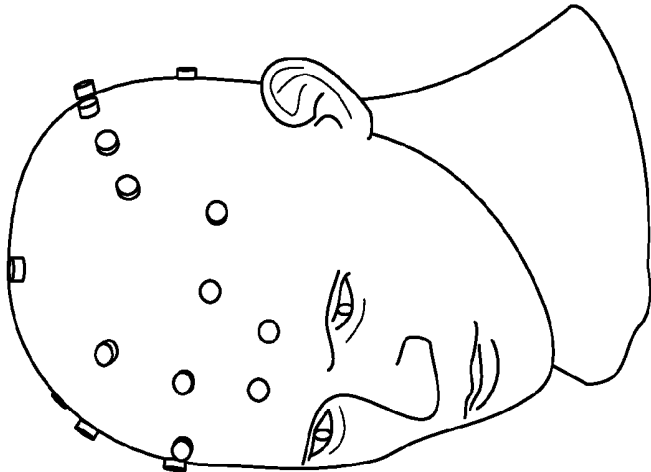

FIG. 22A

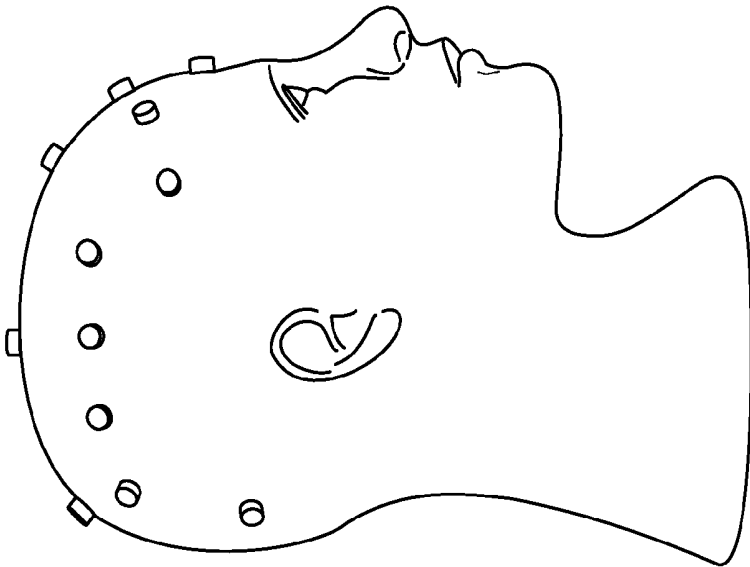

FIG. 22F

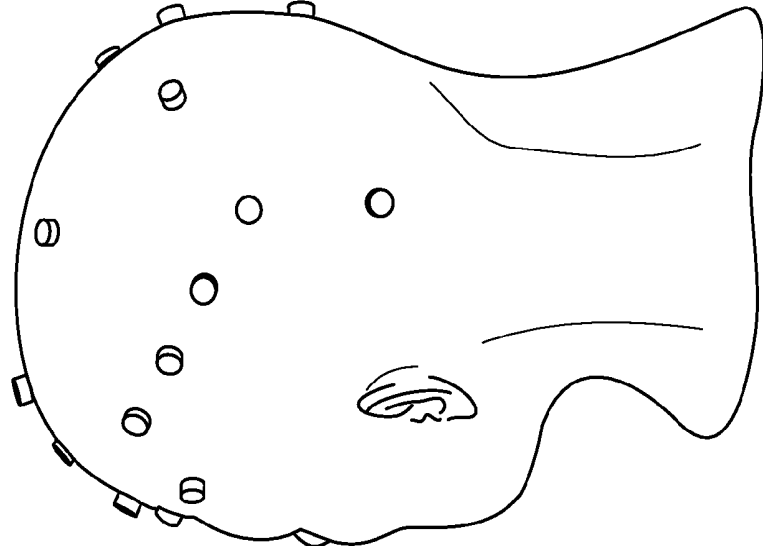

FIG. 22E

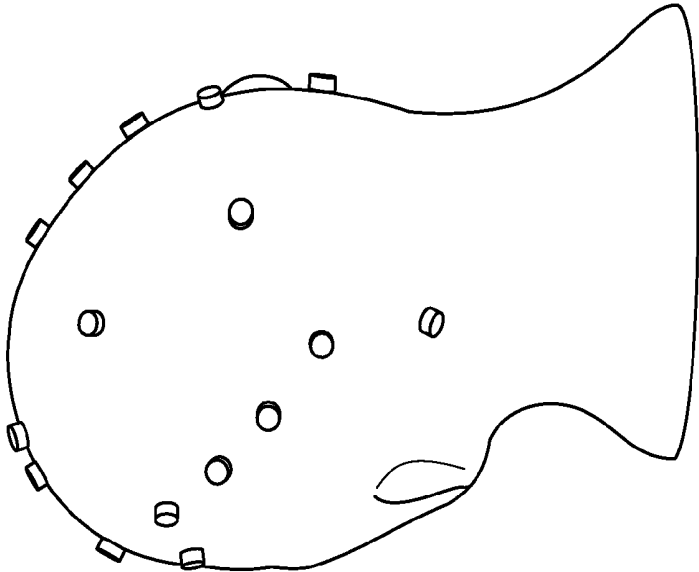

FIG. 22D

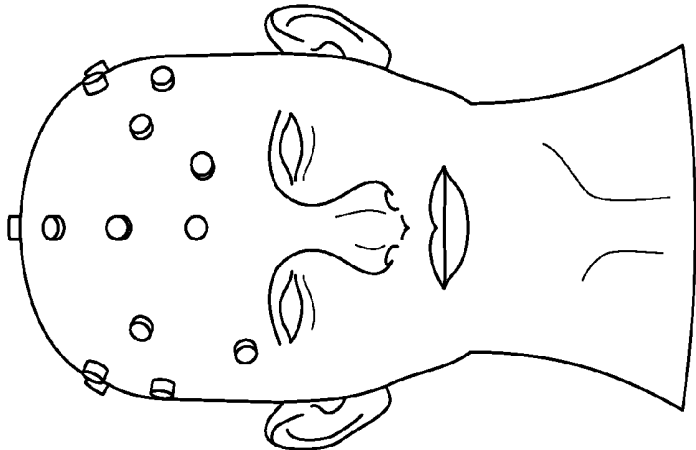

FIG. 22I

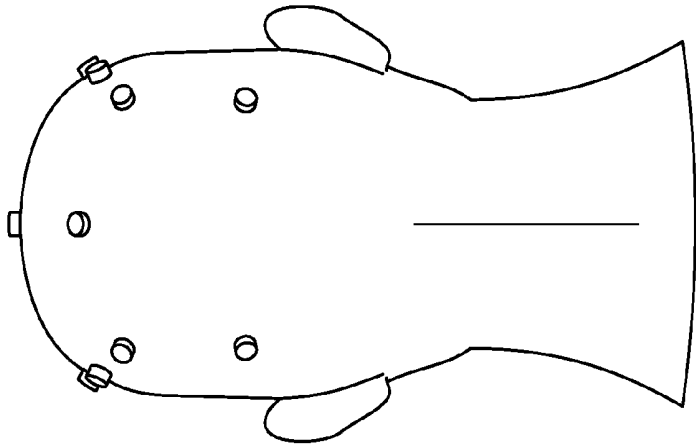

FIG. 22H

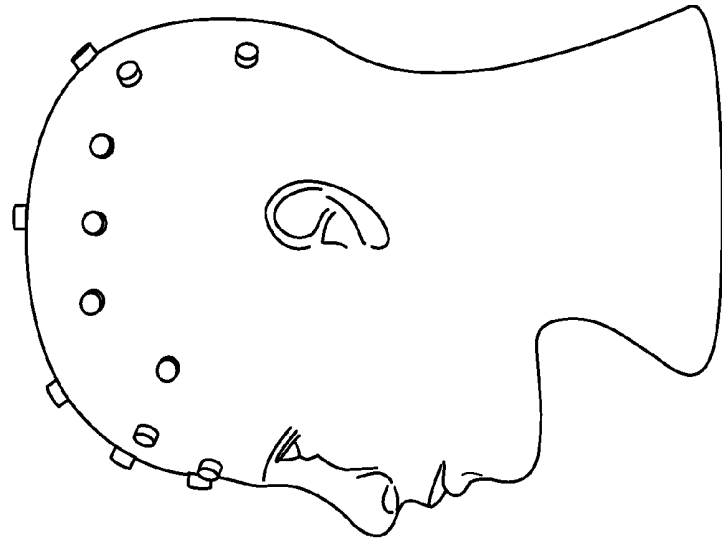

FIG. 22G

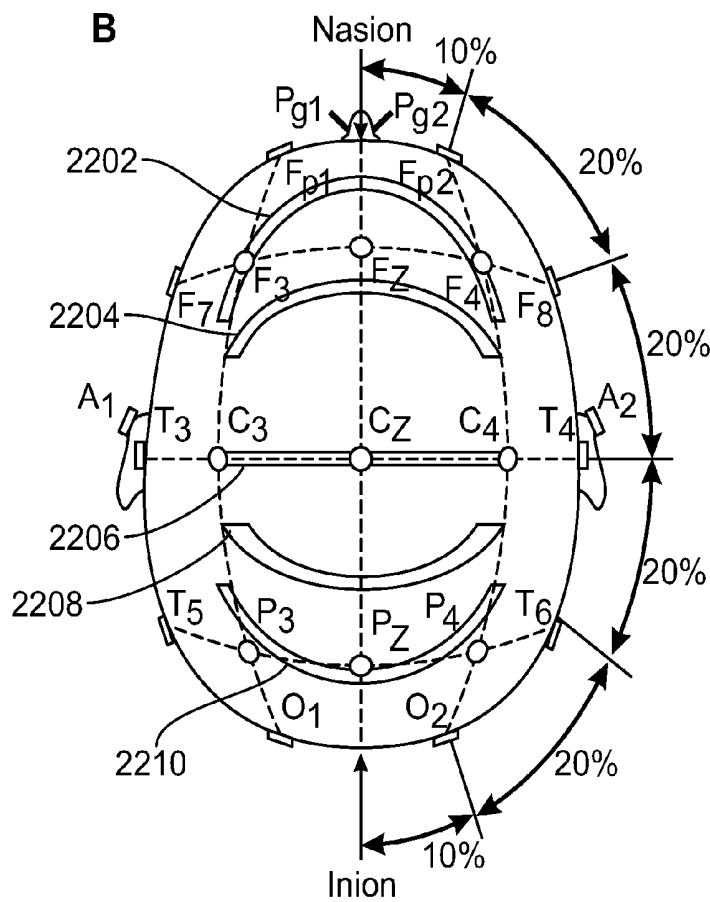
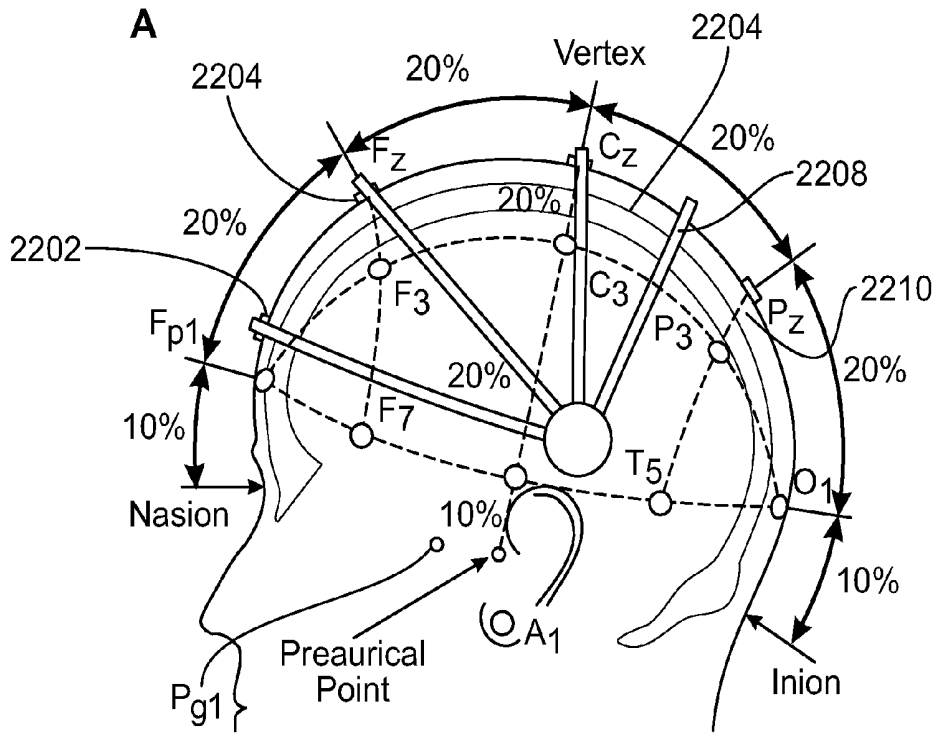

FIG. 22J

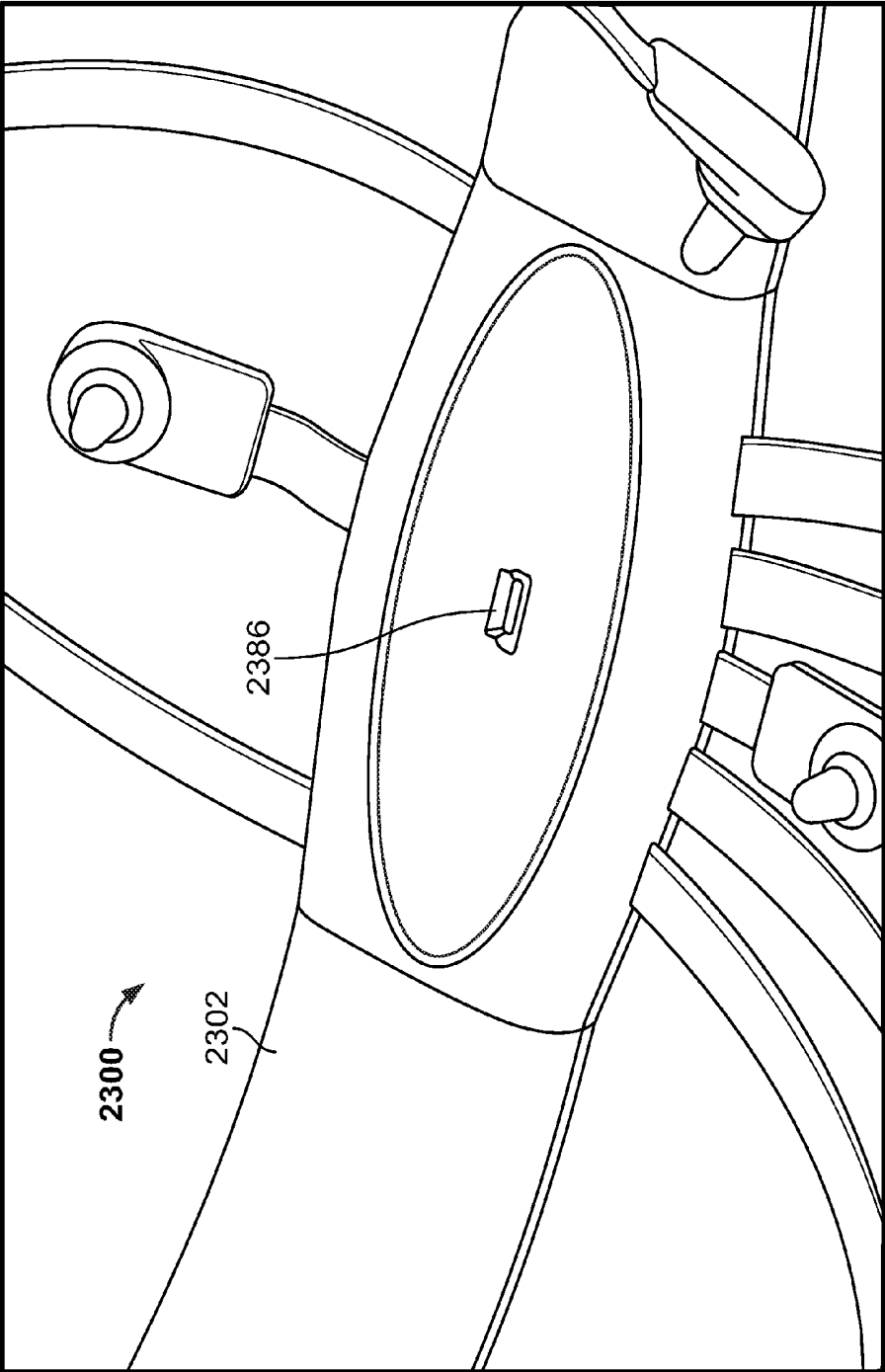

FIG. 24

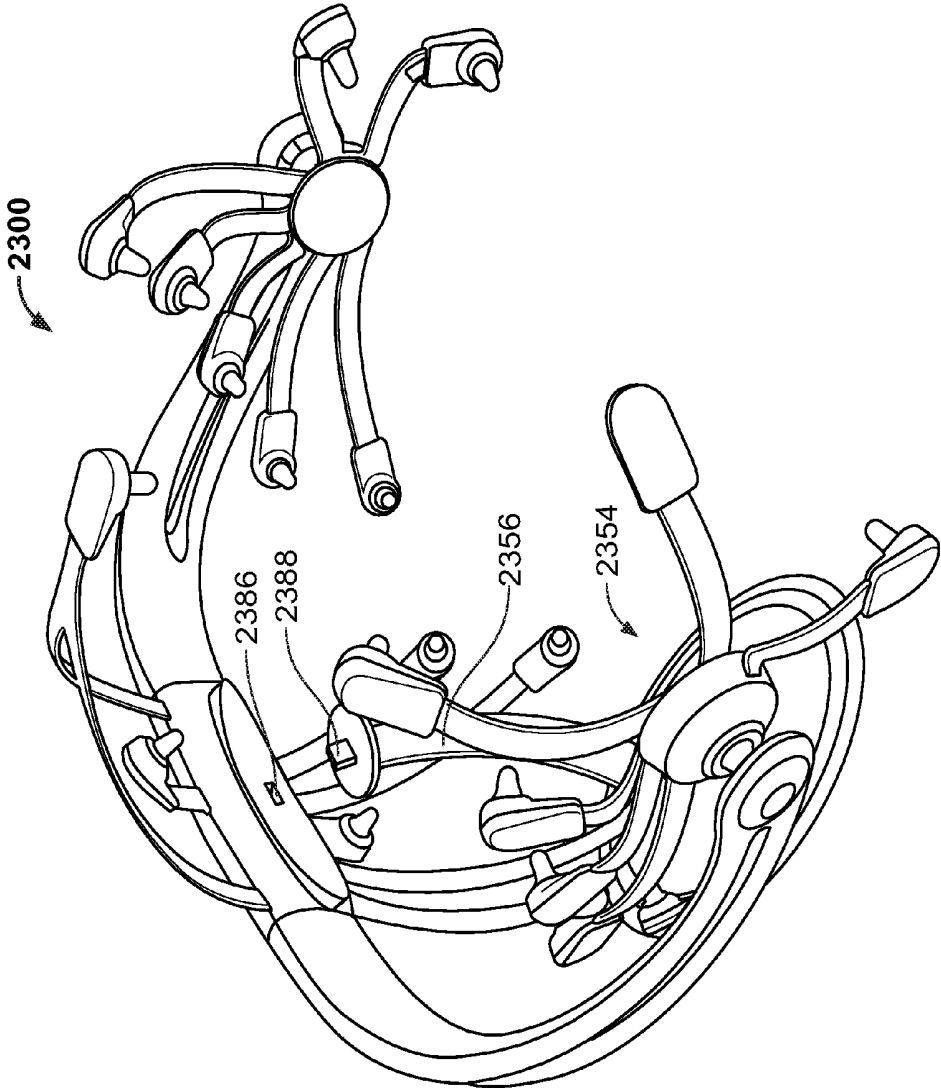

FIG. 25

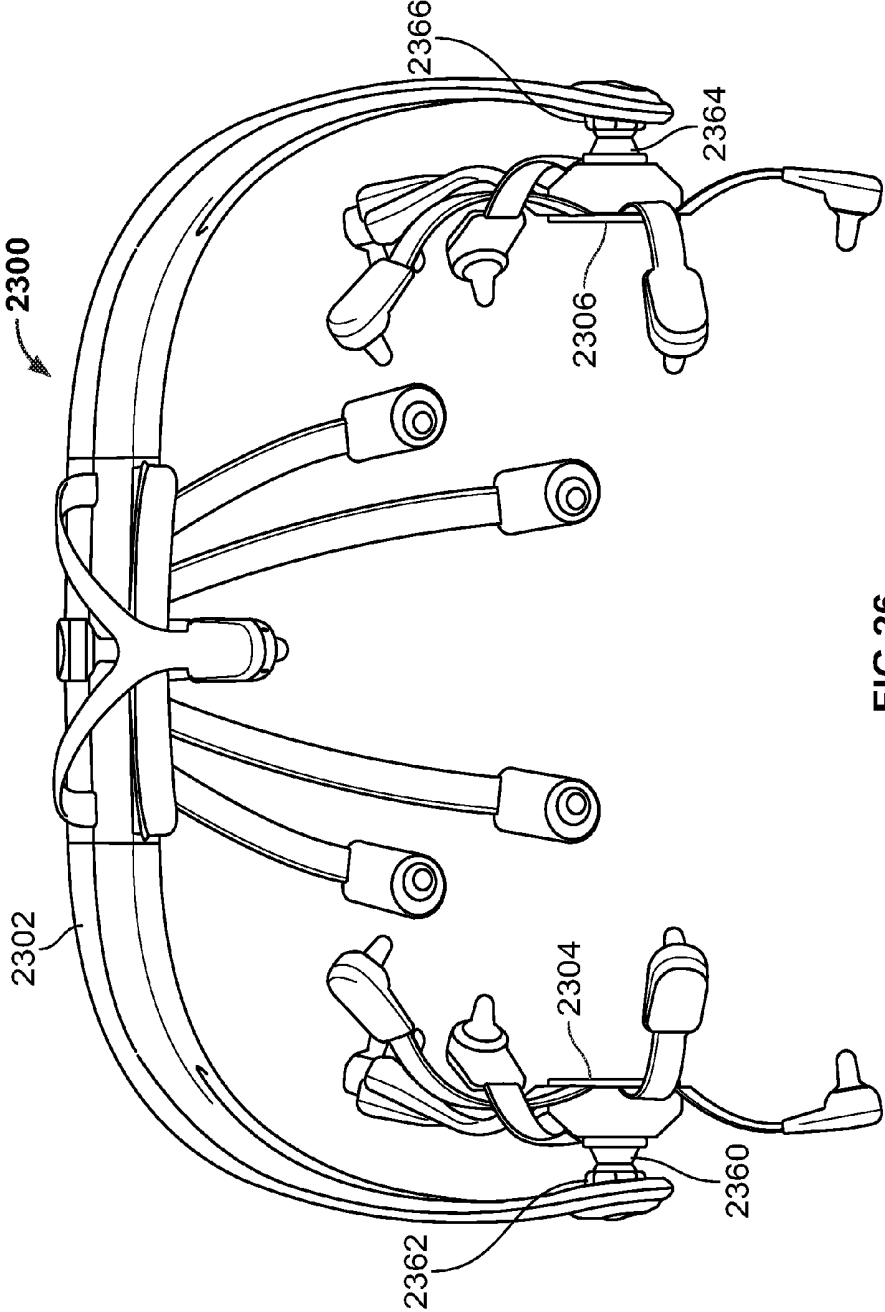

FIG 26

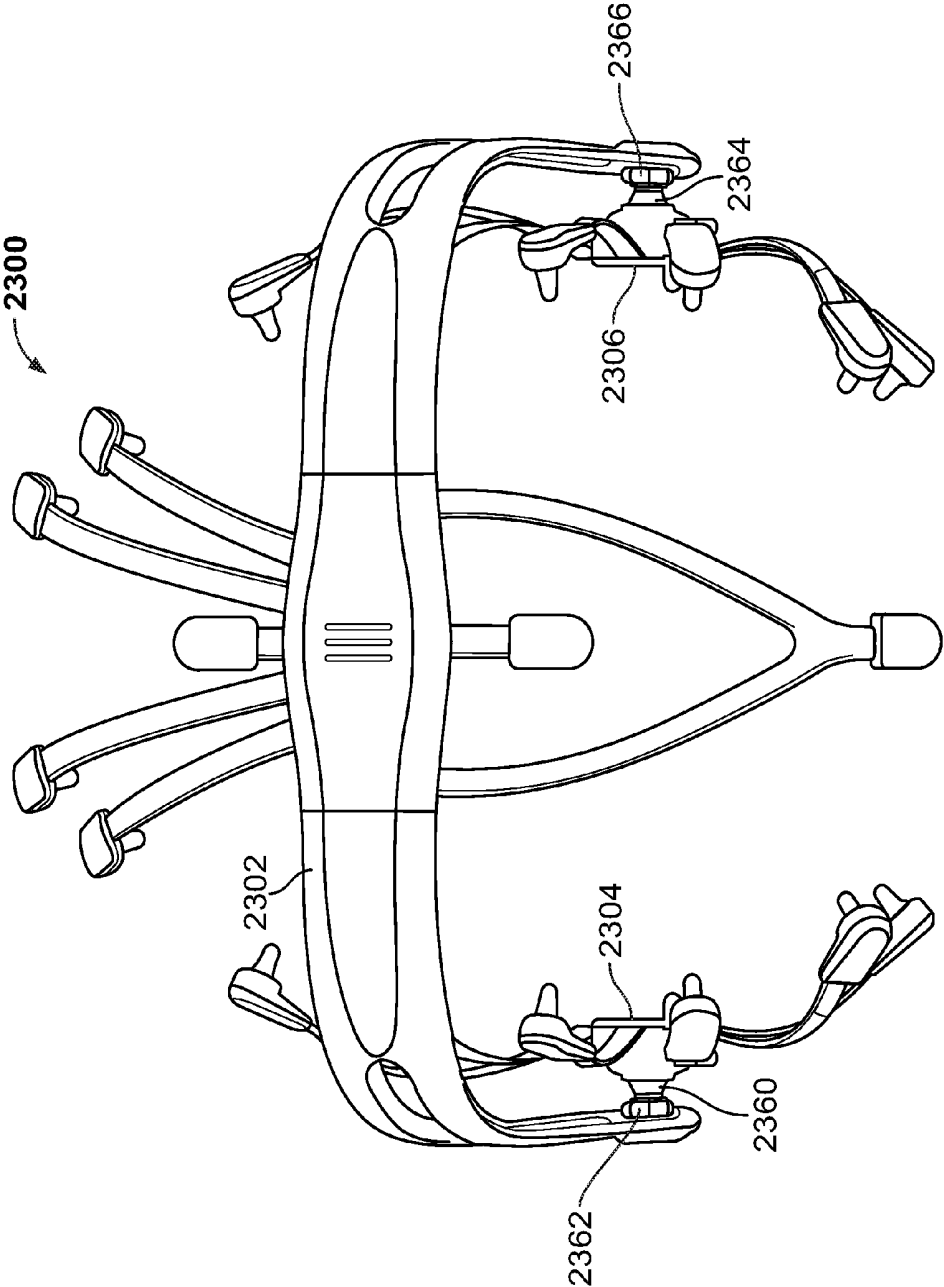

FIG. 27

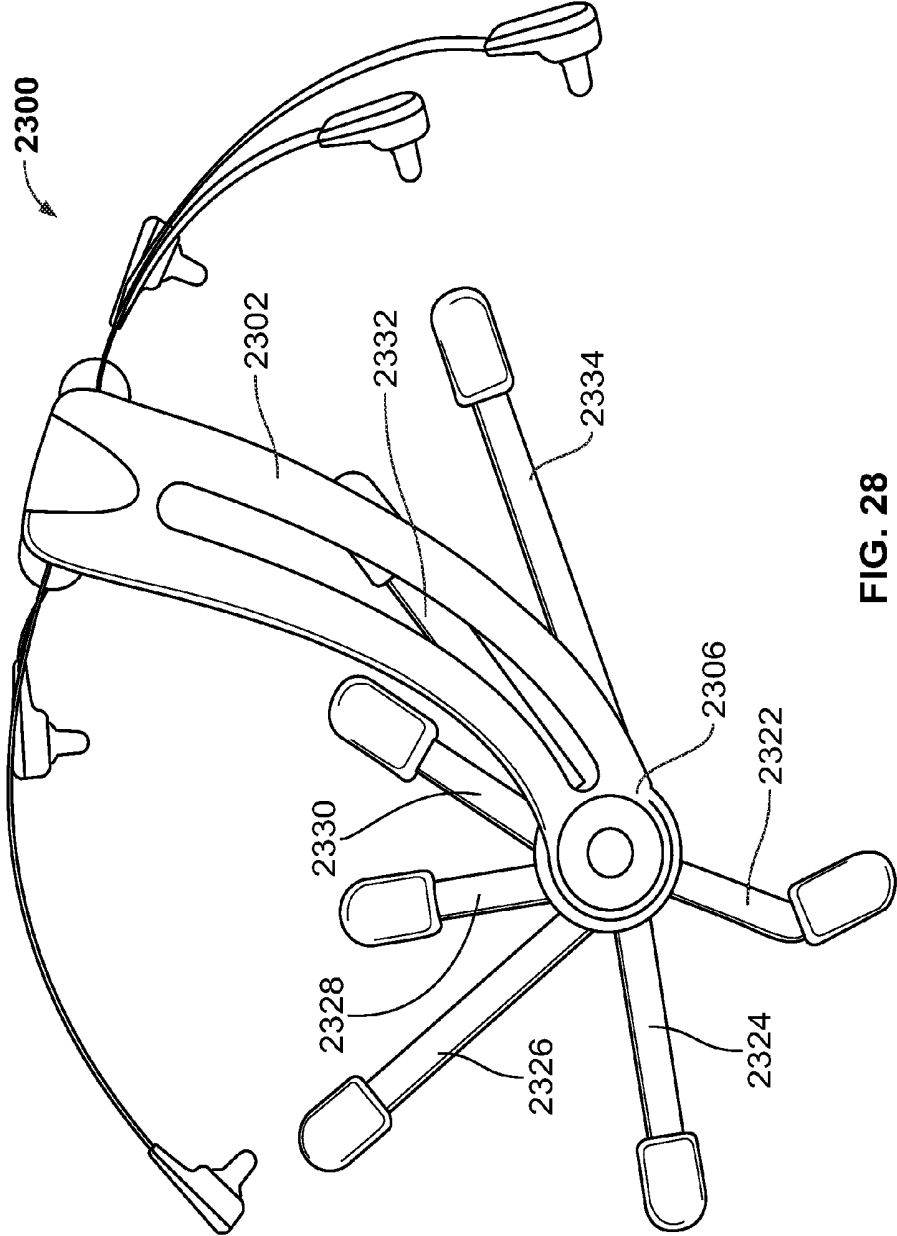

FIG. 28

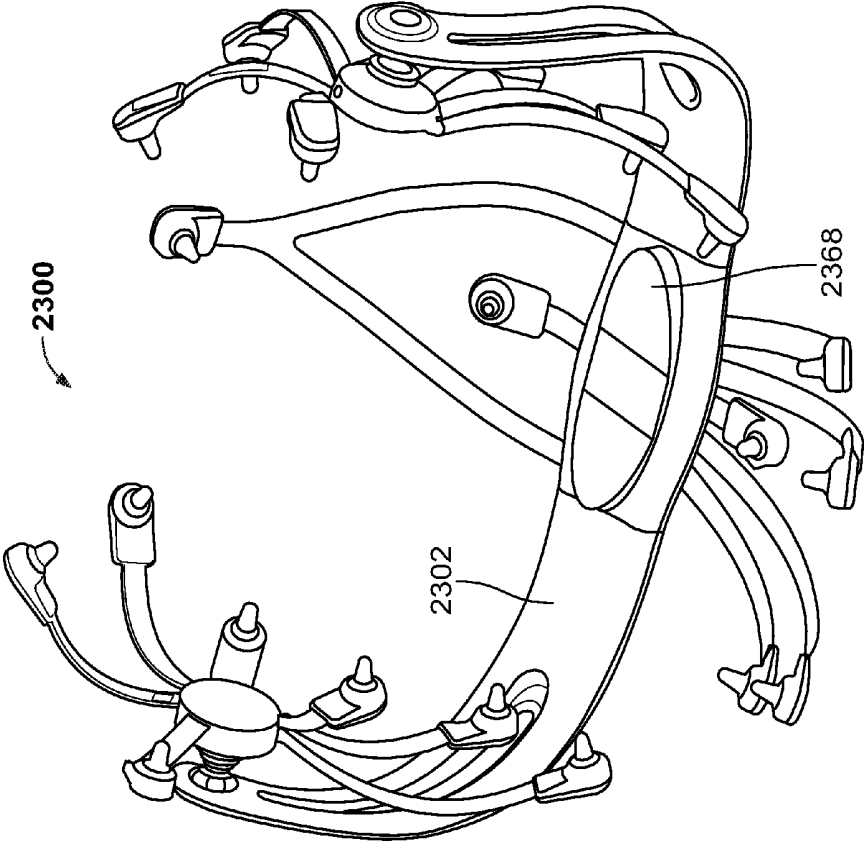

FIG. 29

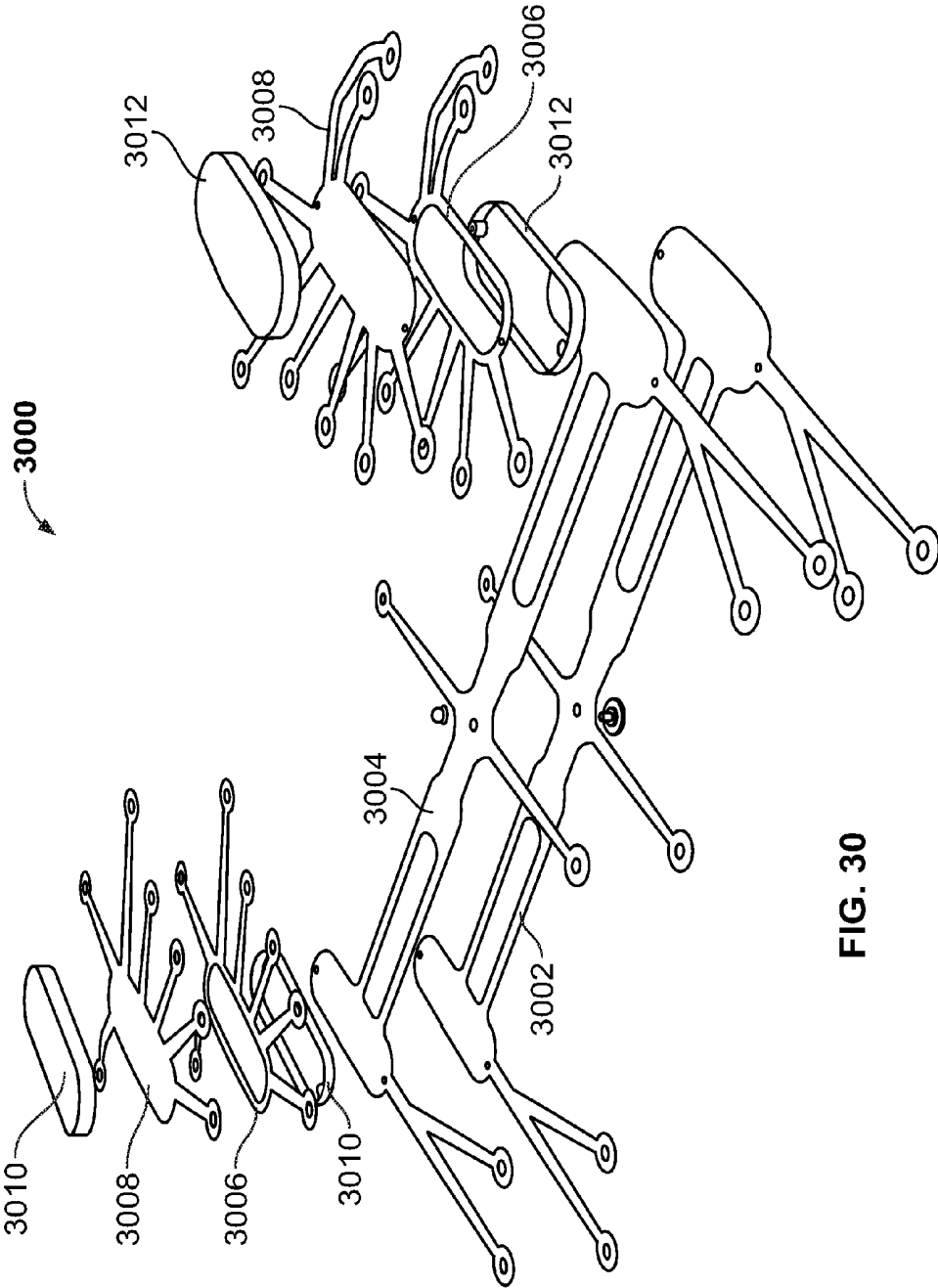

FIG. 30

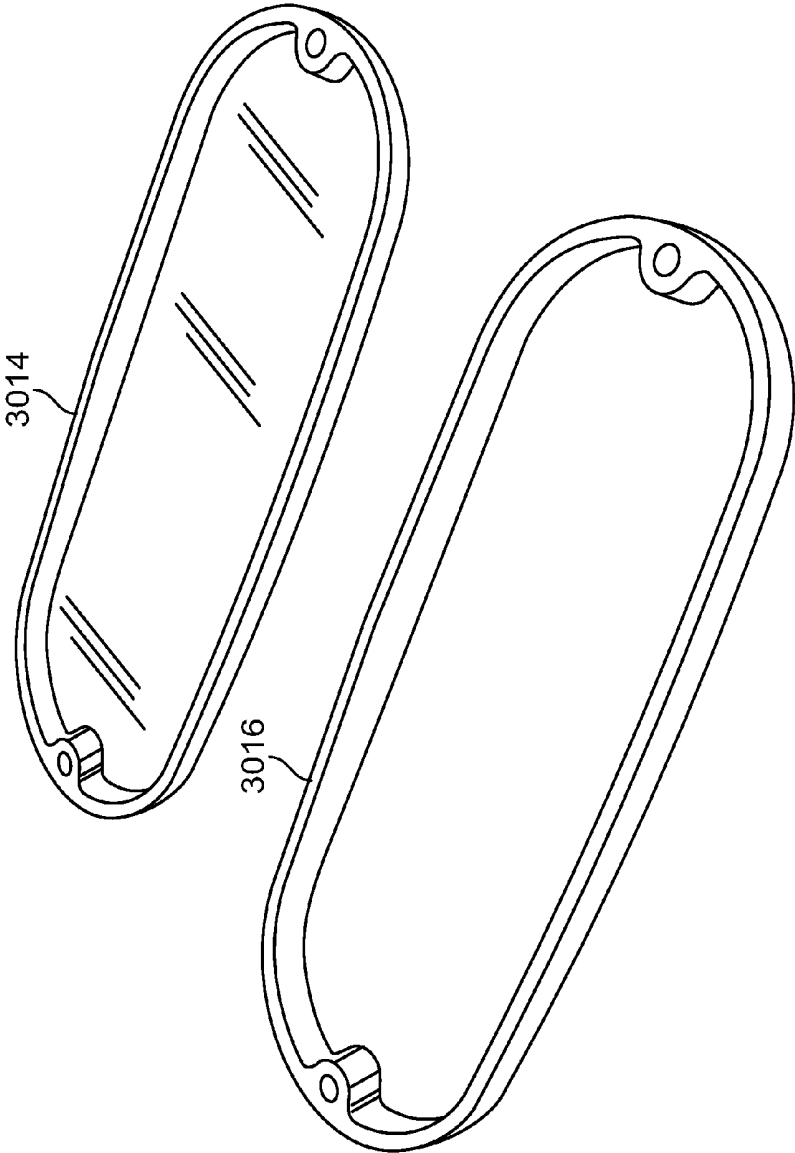

FIG. 31

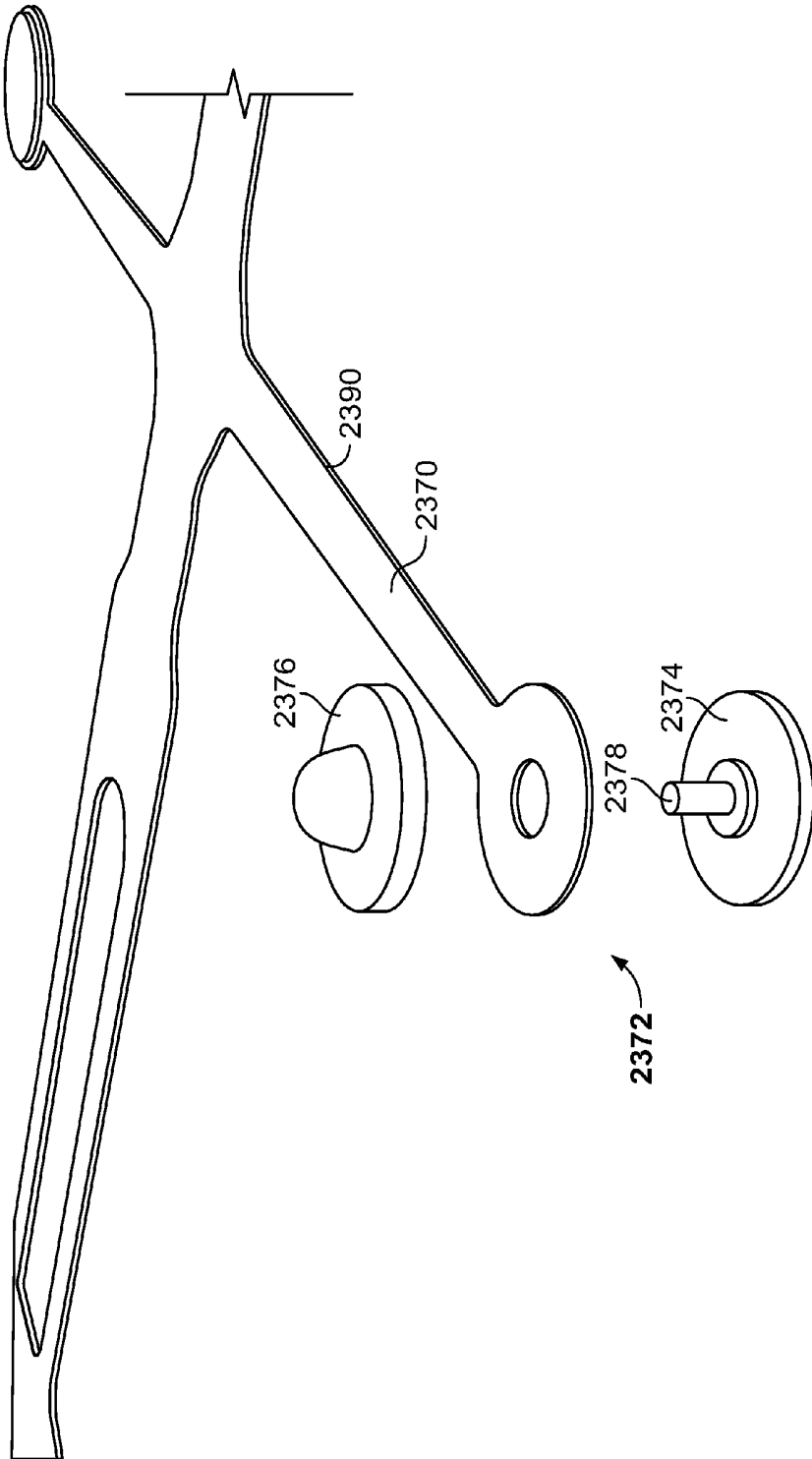

FIG. 32A

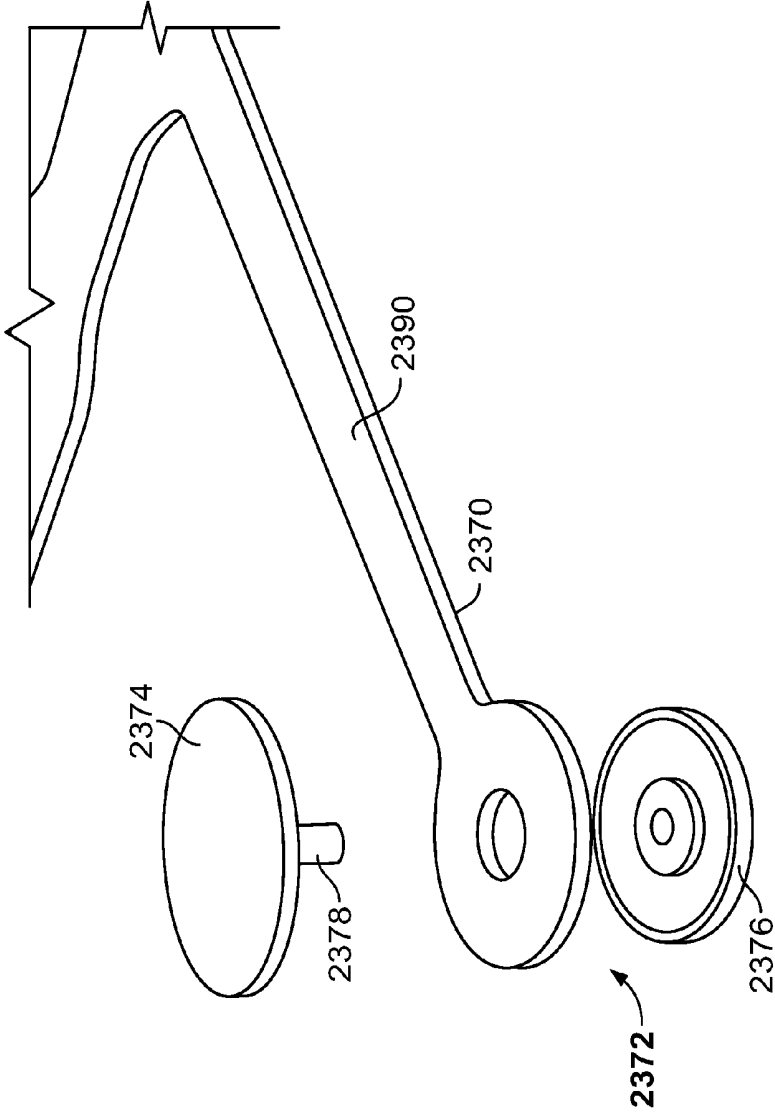

FIG. 32B

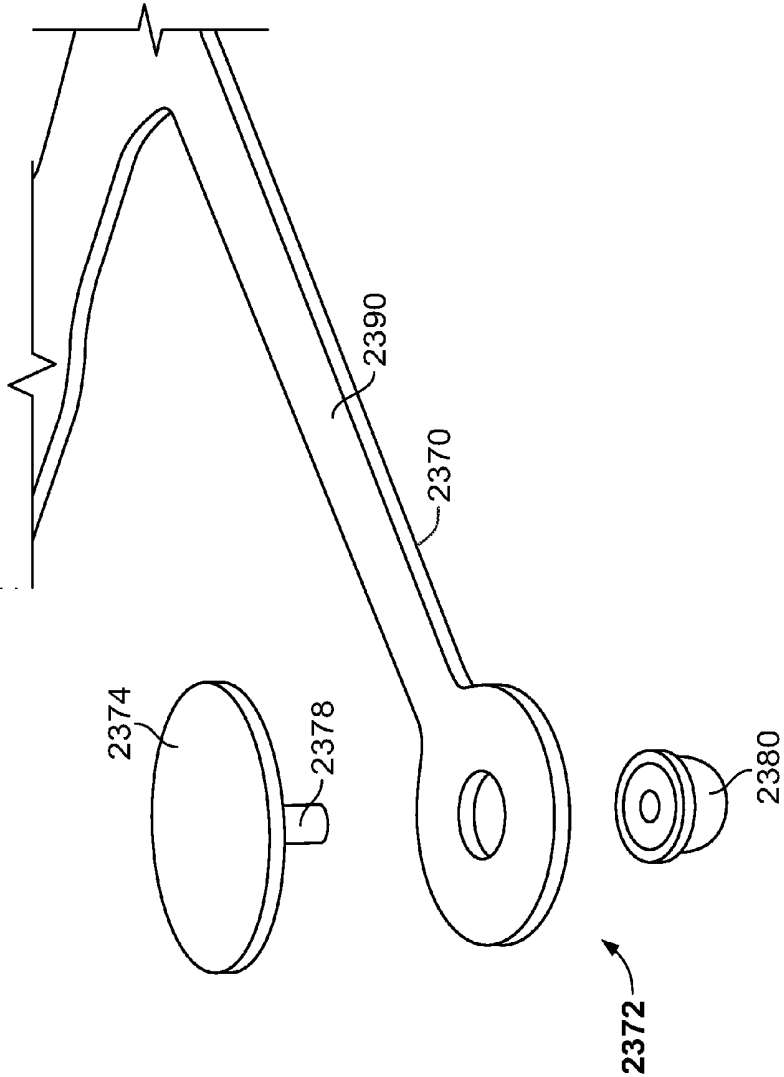

FIG. 32C

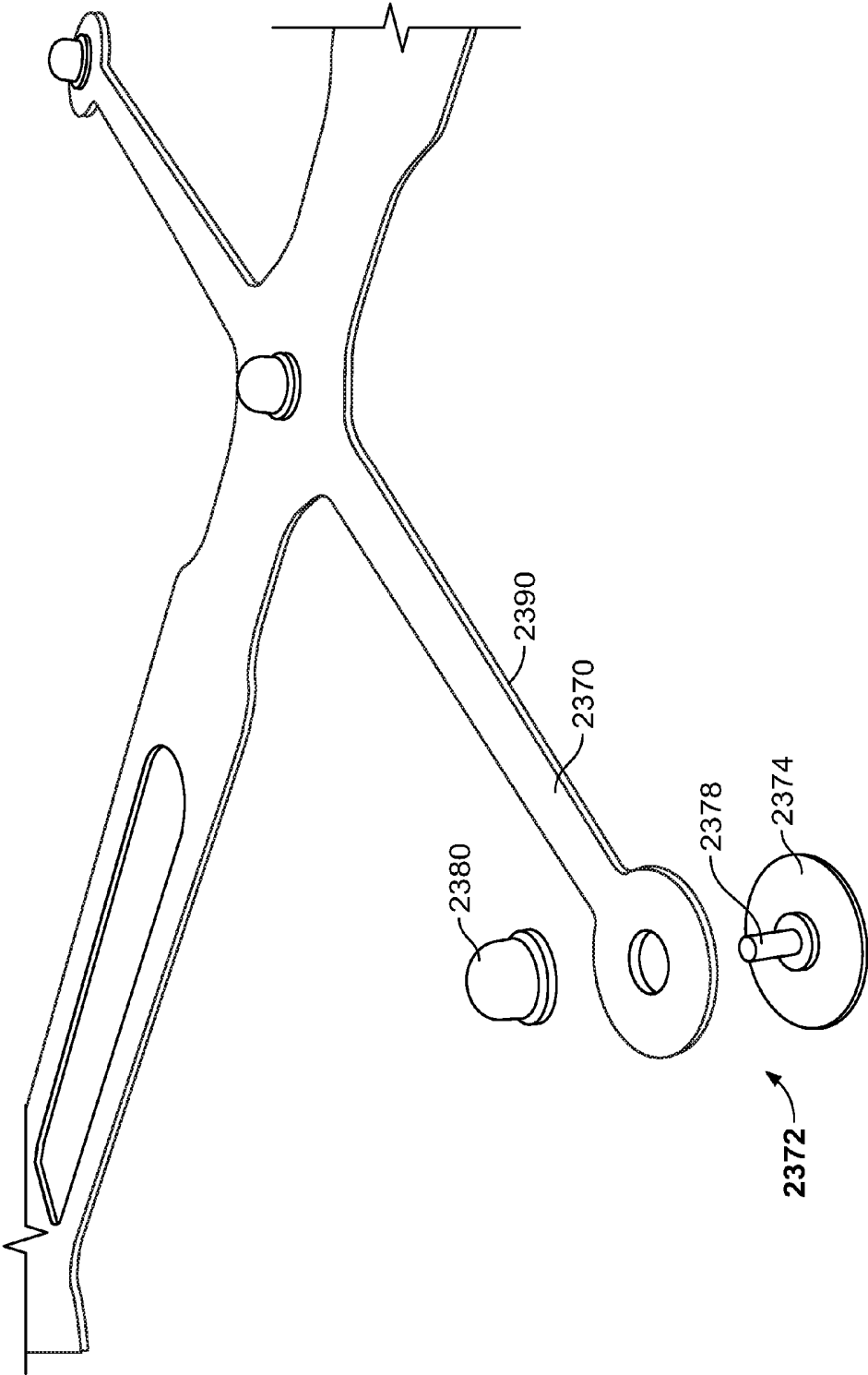

FIG. 32D

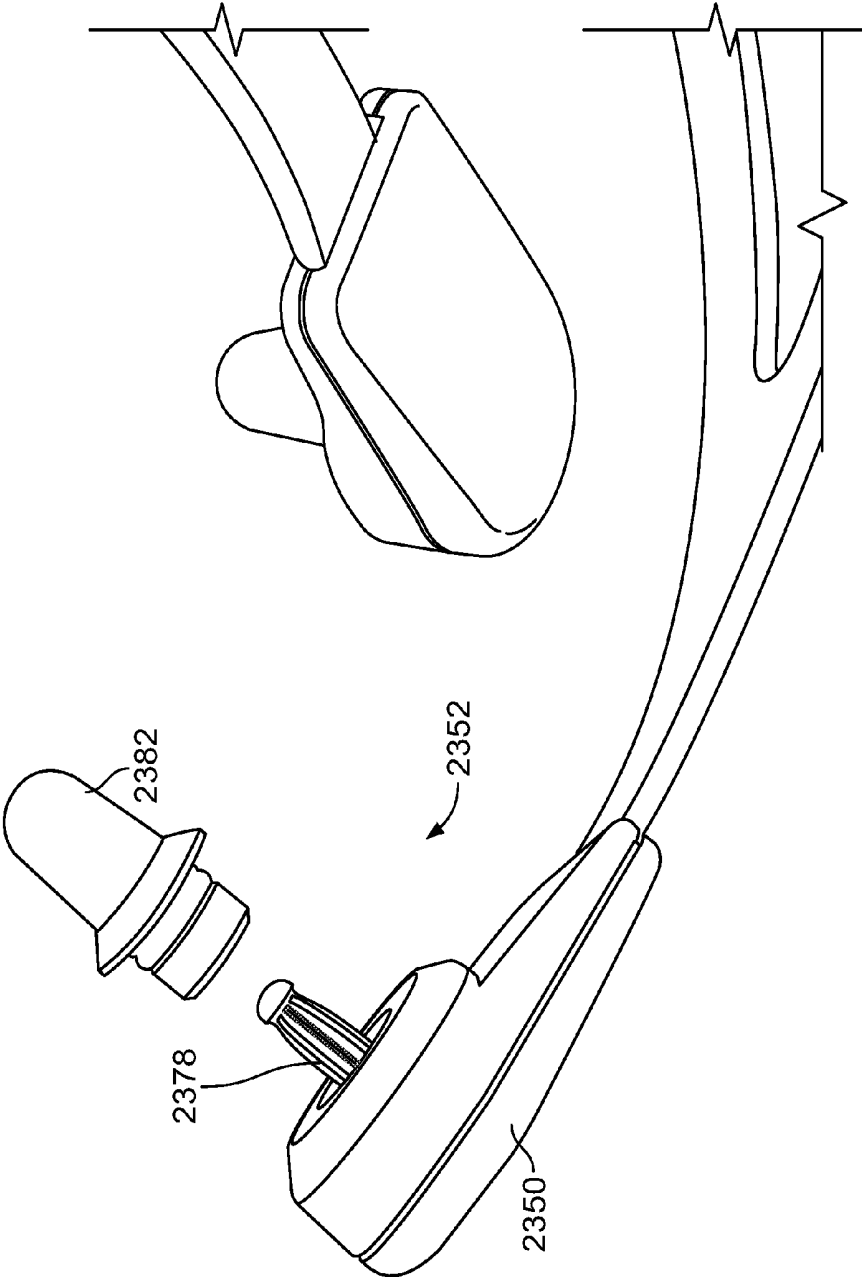

FIG.33

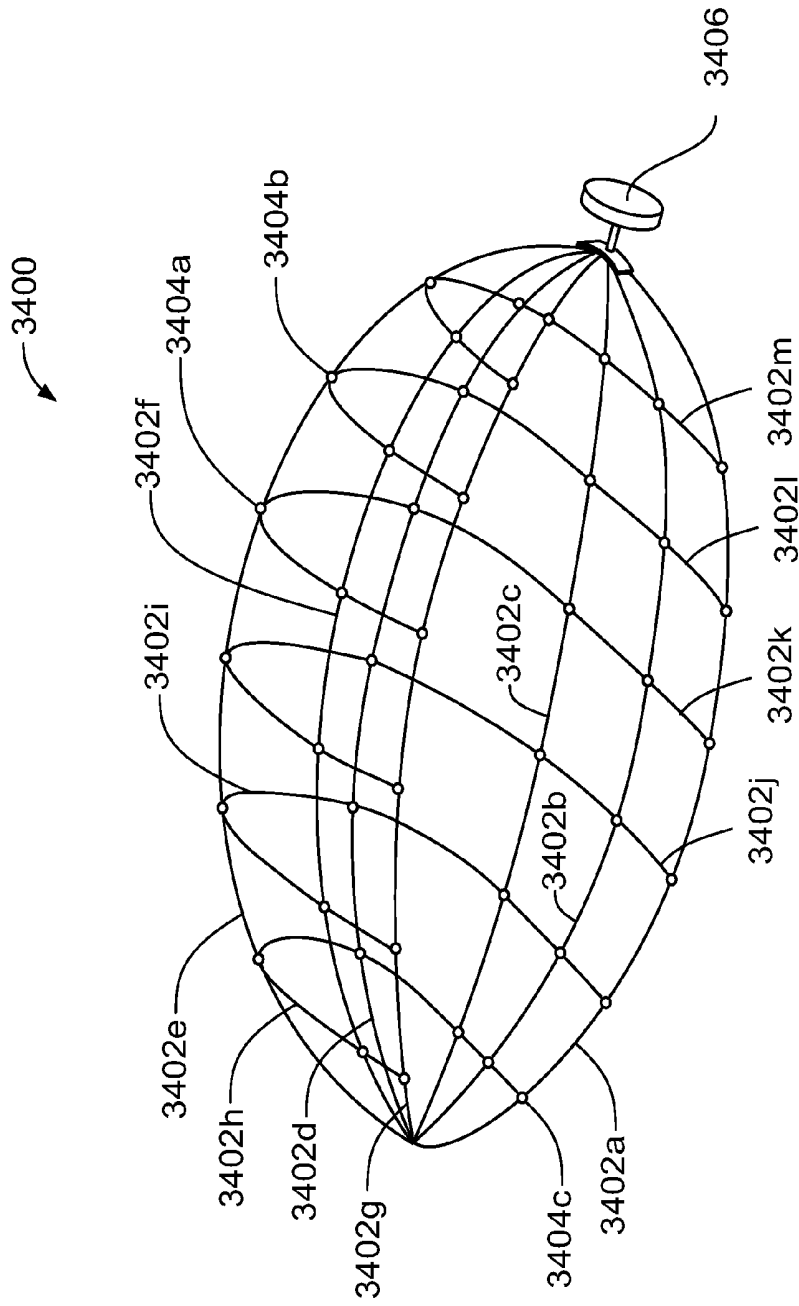

FIG. 34

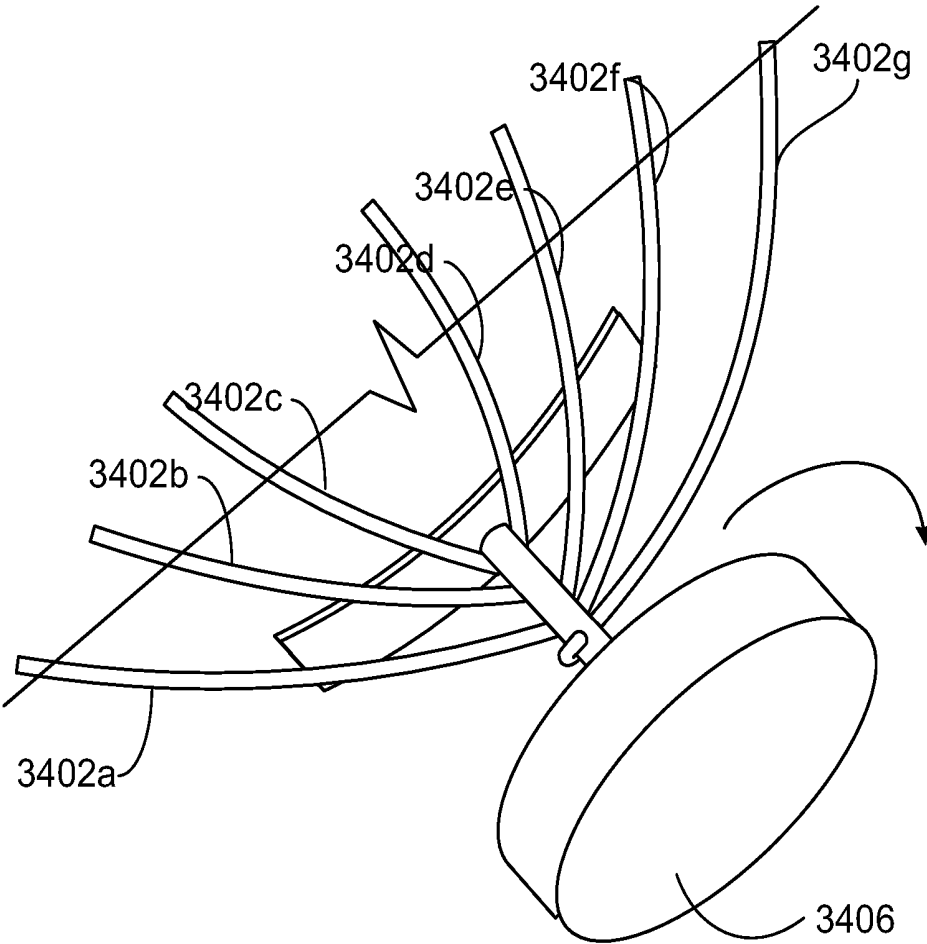

FIG. 35

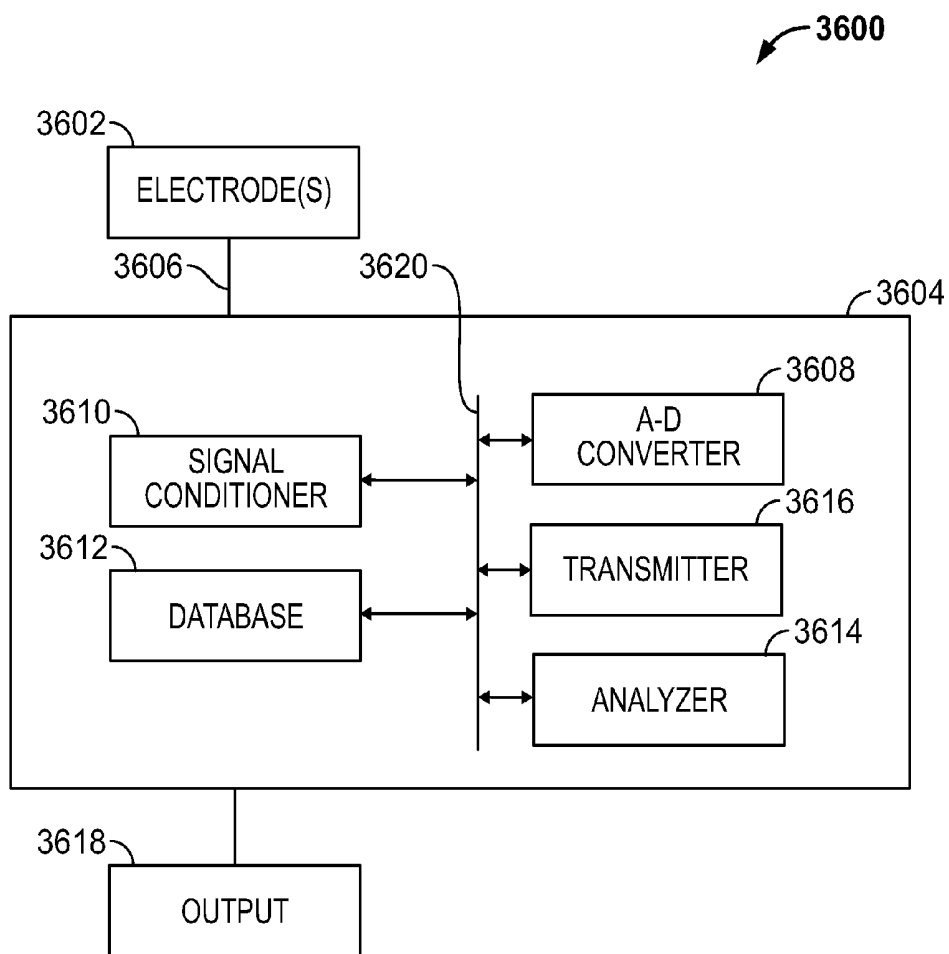

FIG. 36

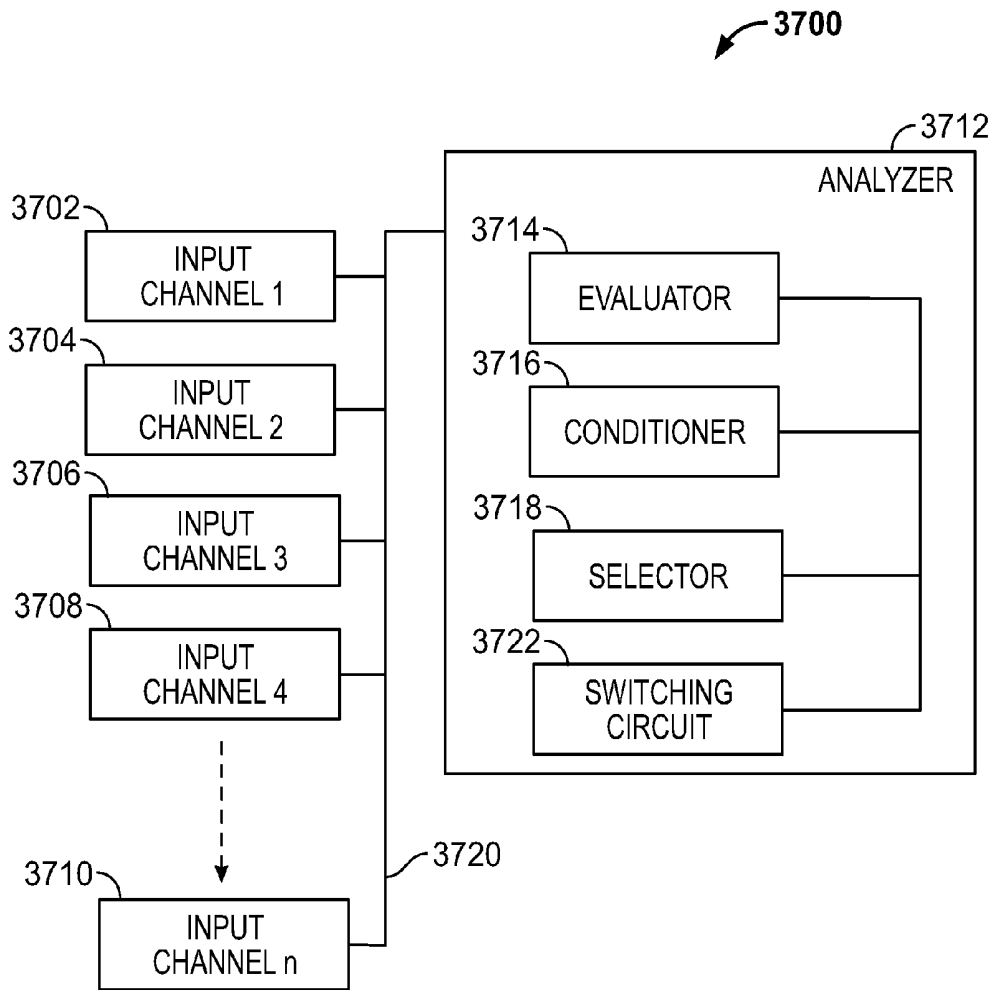

FIG. 37

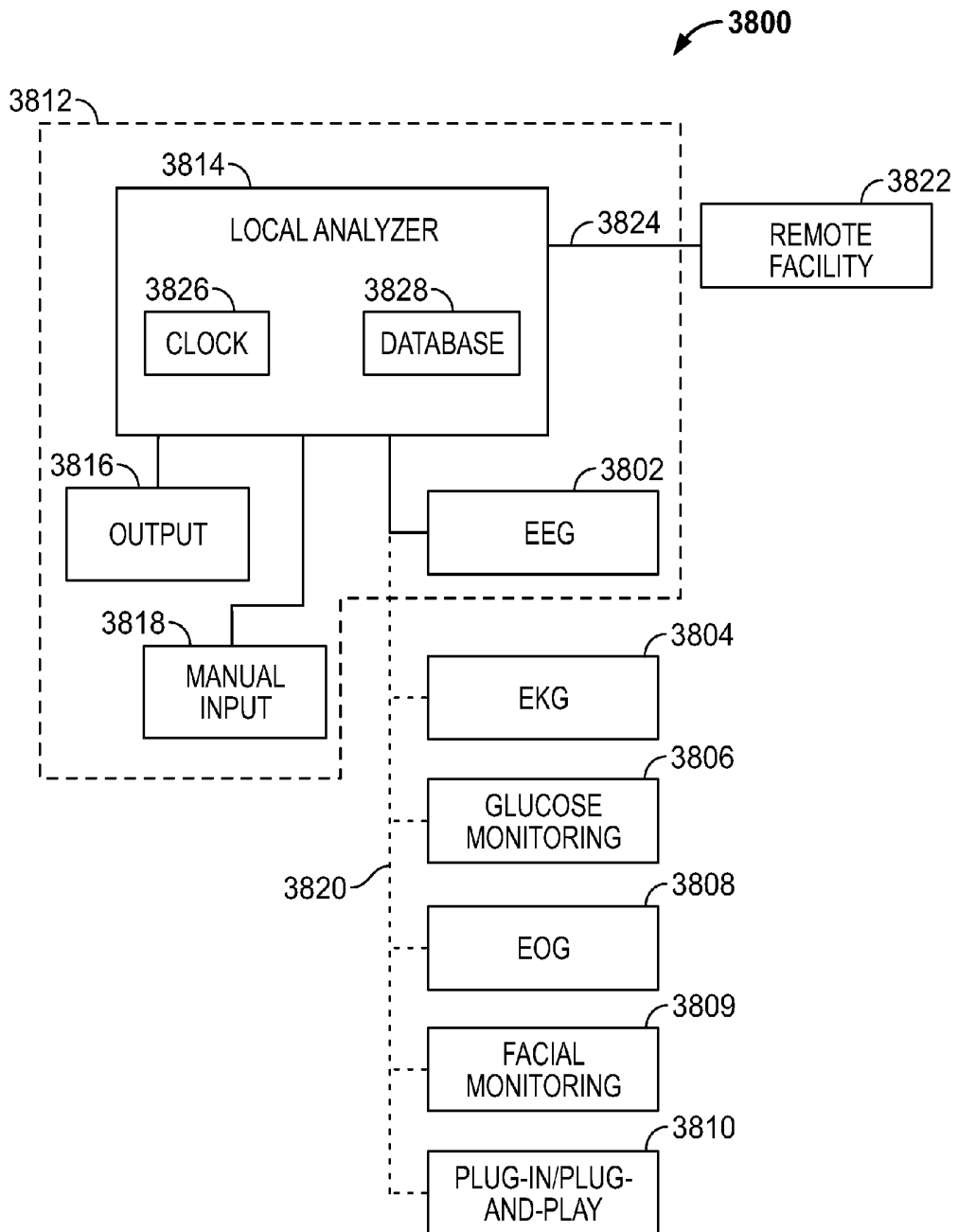

FIG. 38

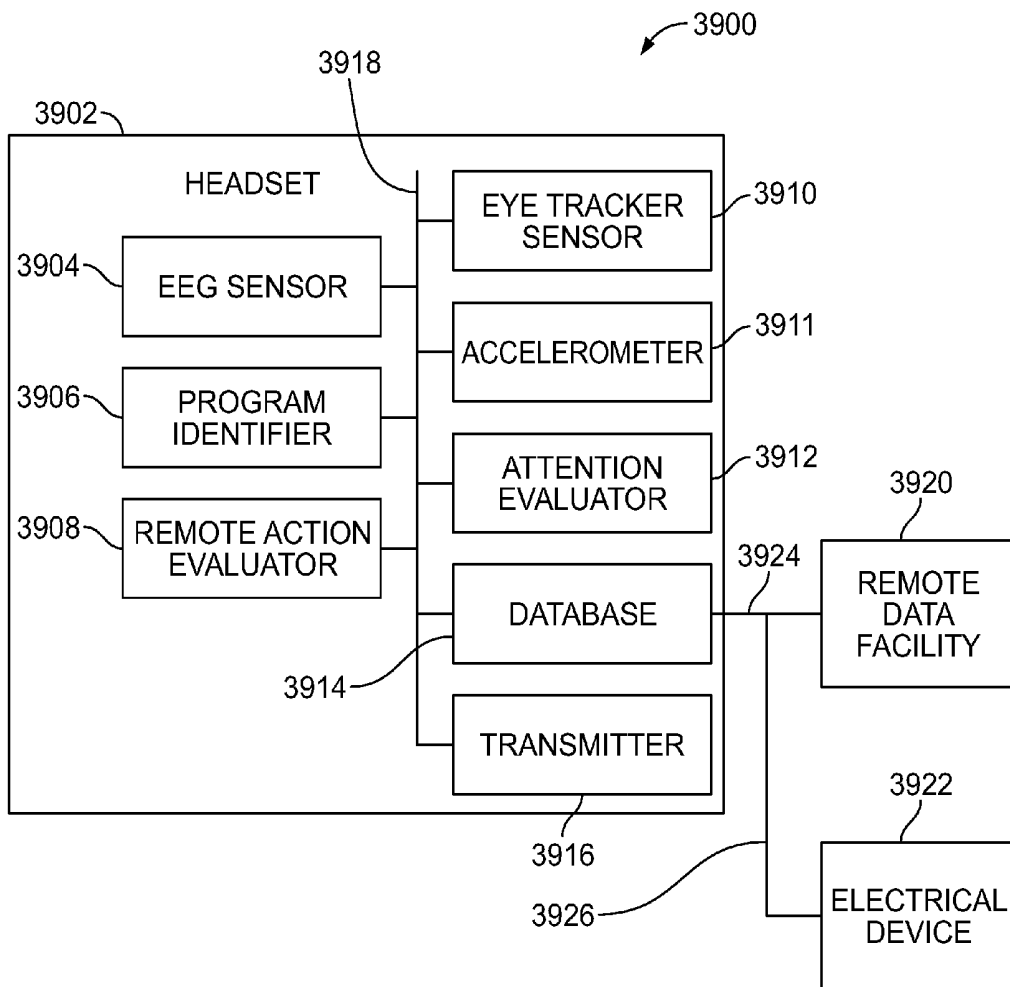

FIG. 39

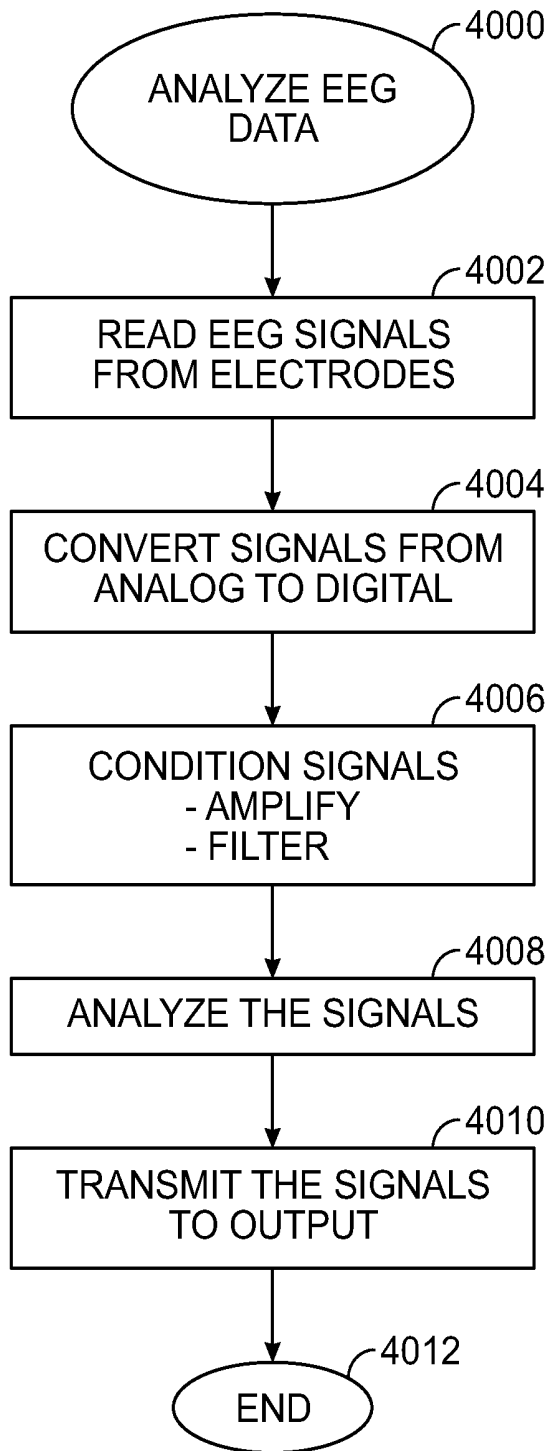

FIG. 40

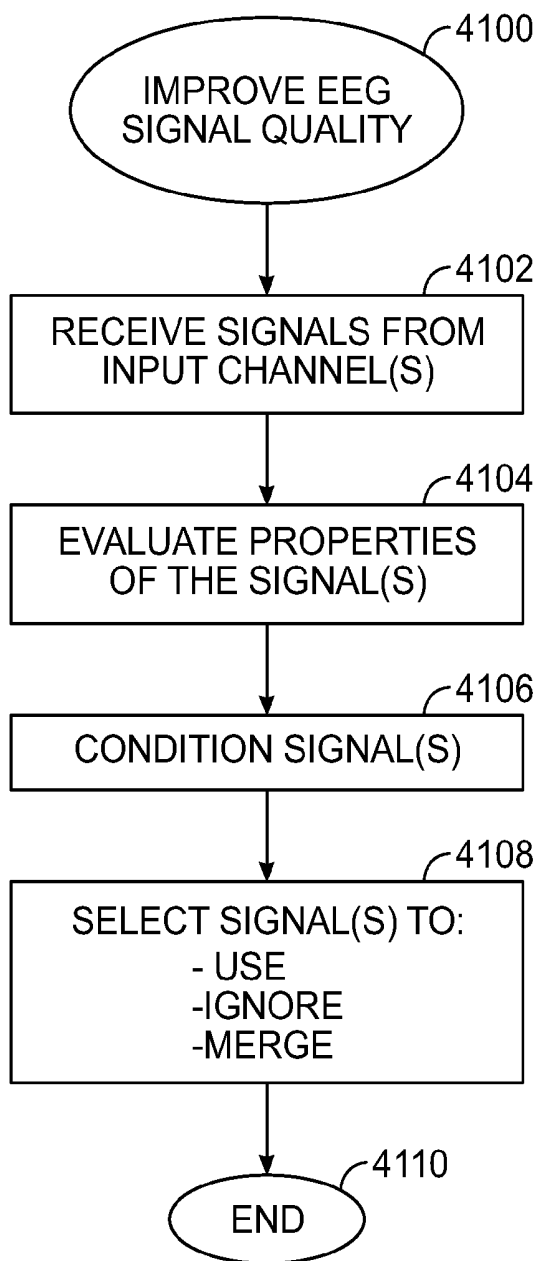

FIG. 41

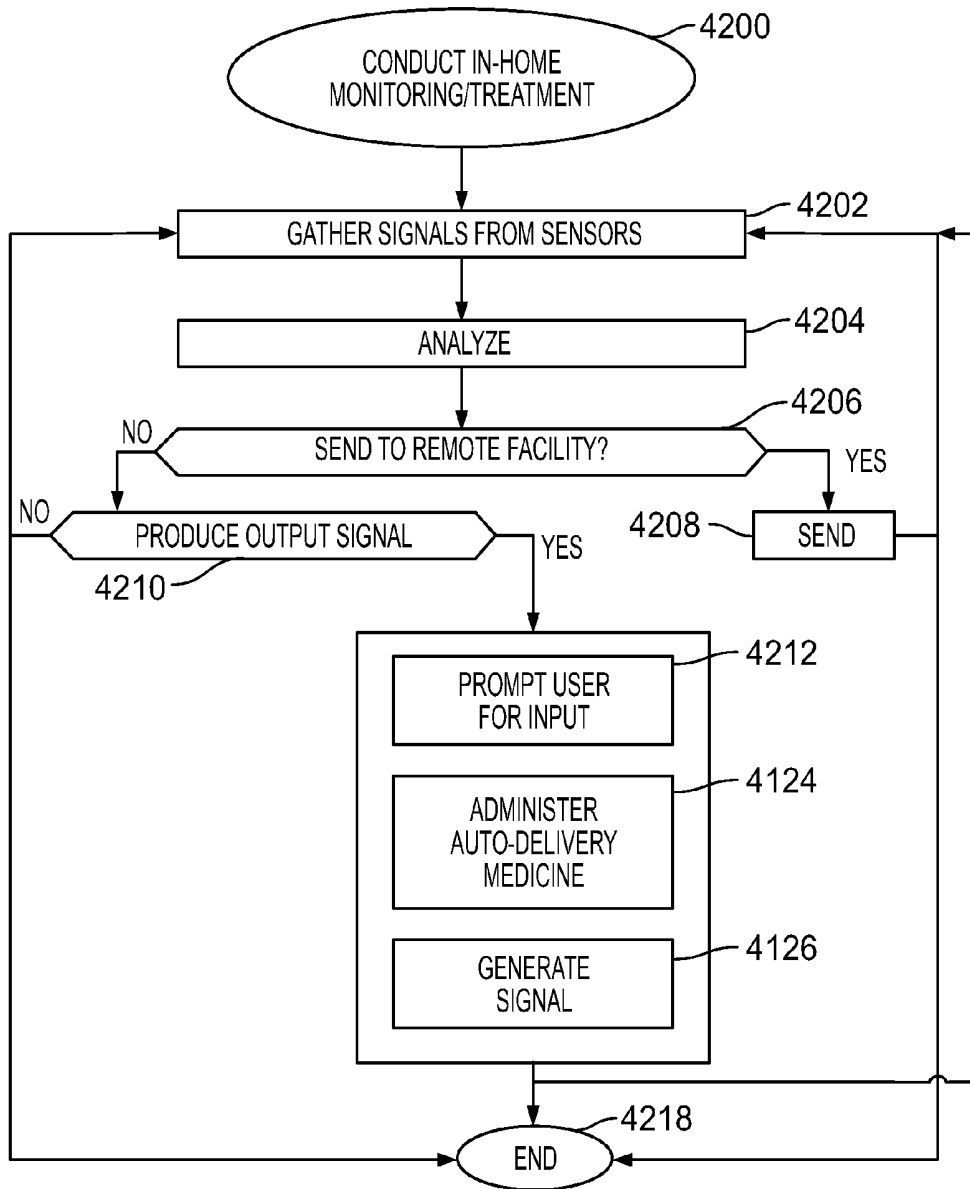

FIG. 42

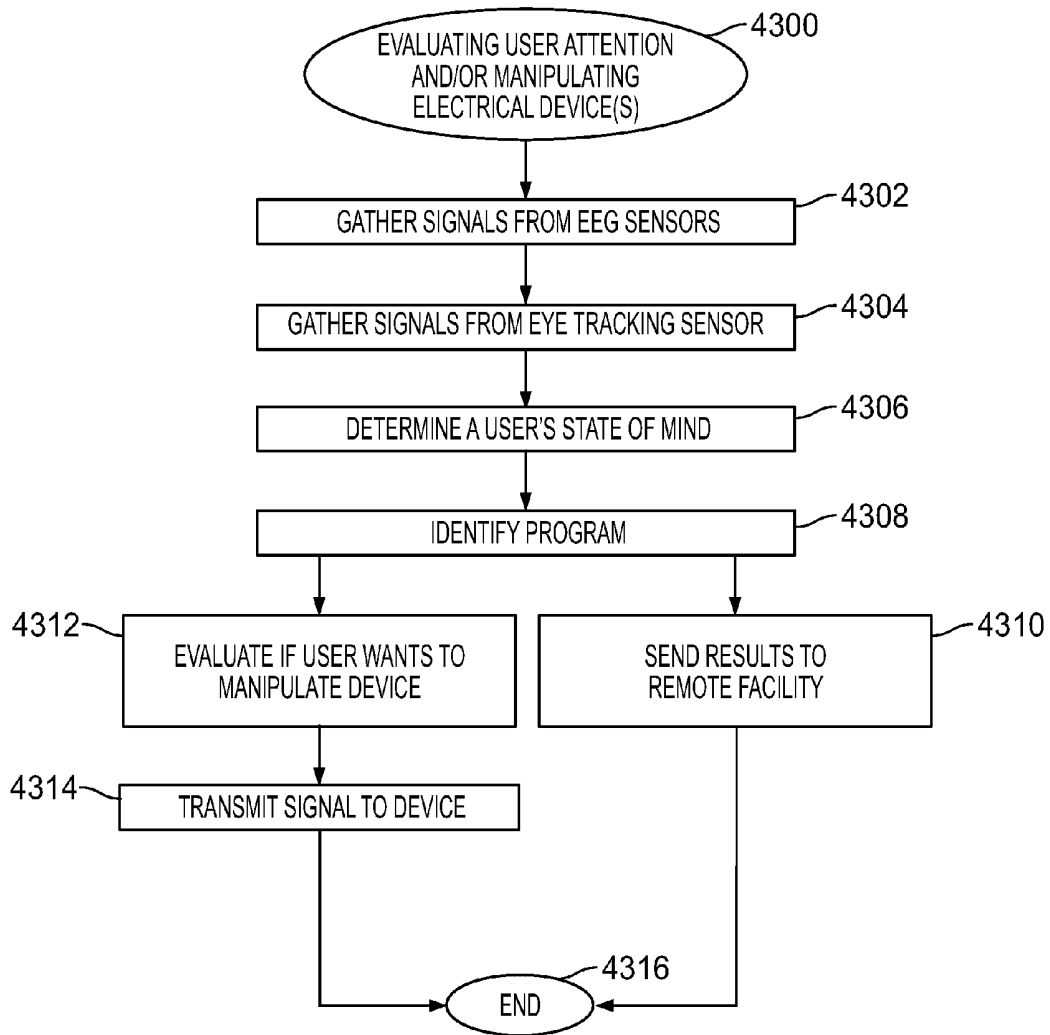

FIG. 43

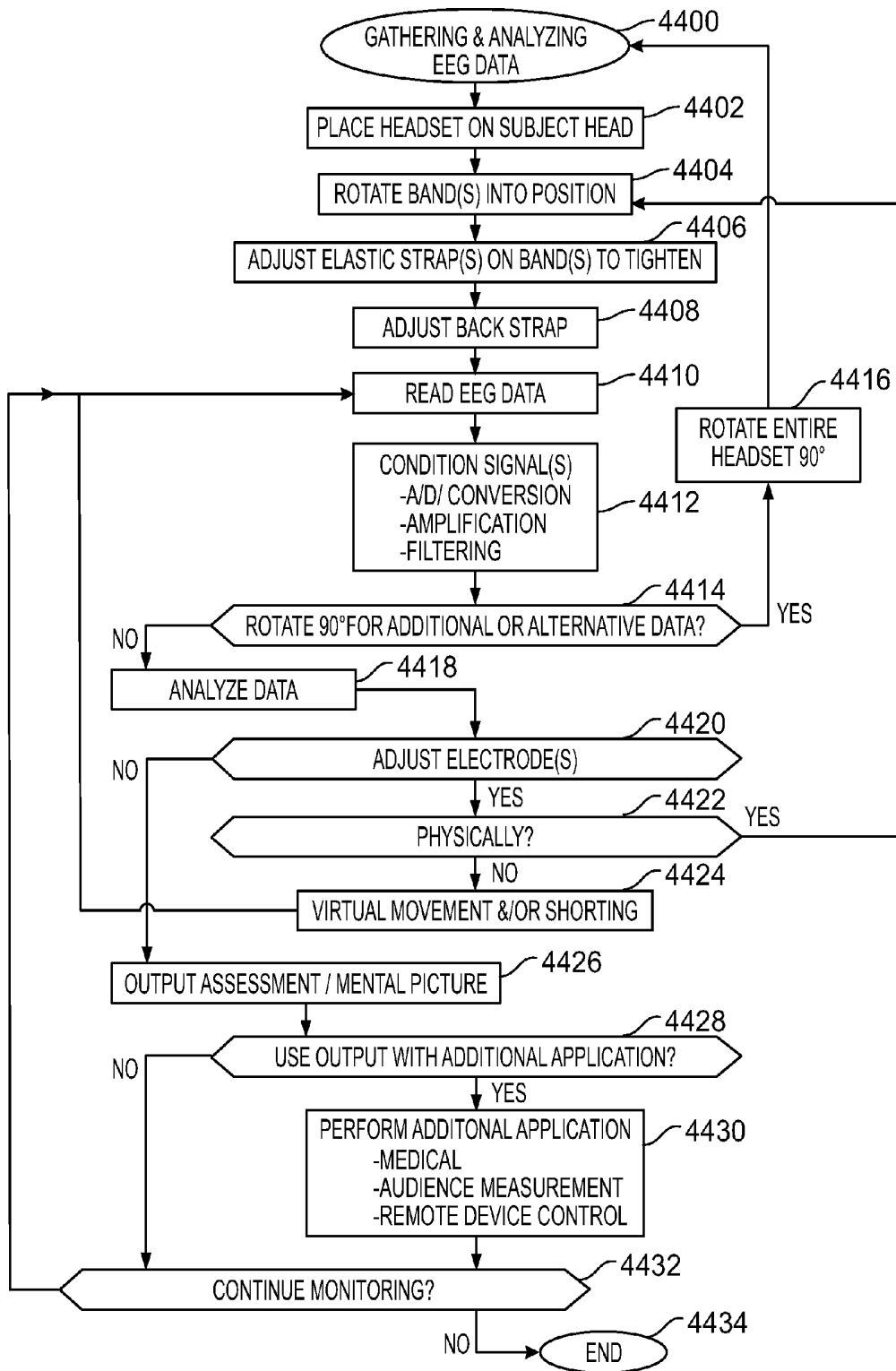

FIG. 44

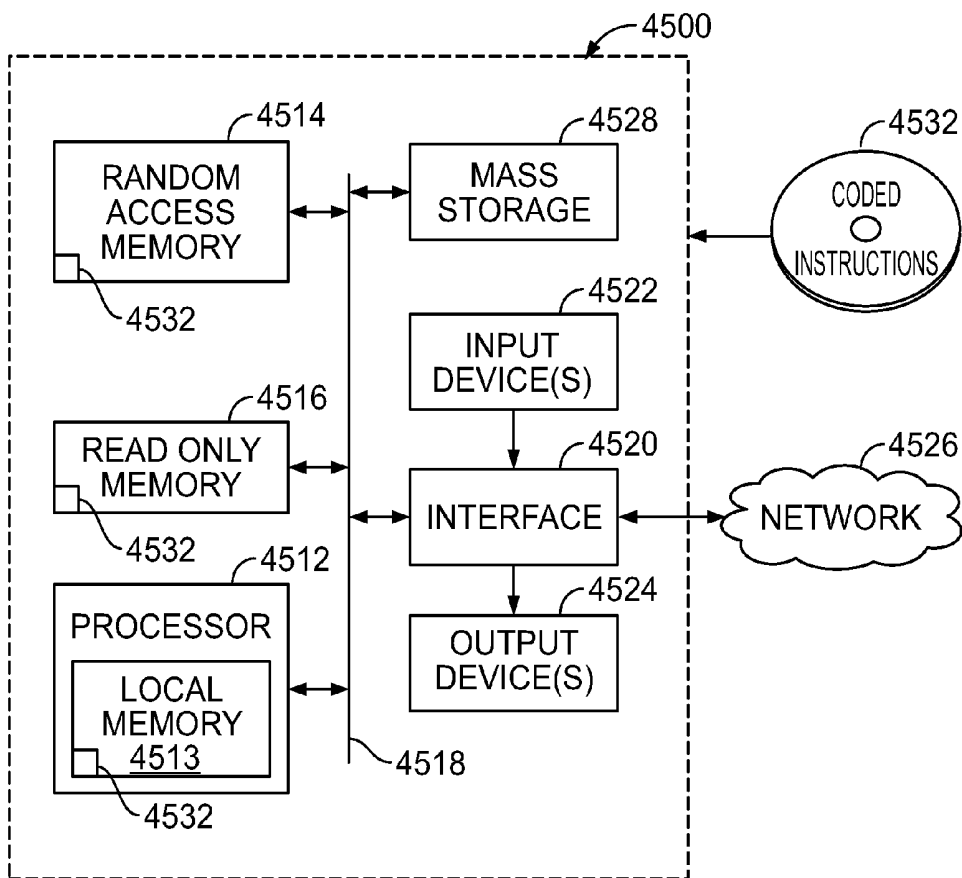

FIG. 45

SYSTEMS AND METHODS TO GATHER AND ANALYZE ELECTROENCEPHALOGRAPHIC DATA

CROSS-REFERENCE TO RELATED APPLICATION

[0001] This patent arises from a continuation of U.S. application Ser. No. 13/730,212, titled “SYSTEMS AND METHODS TO GATHER AND ANALYZE ELECTROENCEPHALOGRAPHIC DATA,” filed Dec. 28, 2012, which claims the benefit under 35 U.S.C. §119(e) to U.S. Provisional Application No. 61/684,640 titled “SYSTEMS AND METHODS TO GATHER AND ANALYZE ELECTROENCEPHALOGRAPHIC DATA,” filed Aug. 17, 2012. U.S. application Ser. No. 13/730,212 and U.S. Provisional Application No. 61/684,640 are incorporated herein by this reference in their entireties.

FIELD OF THE DISCLOSURE

[0002] The present disclosure relates generally to neurological and physiological monitoring, and, more particularly, to systems and methods to gather and analyze electroencephalographic data.

BACKGROUND

[0003] Electroencephalography (EEG) involves measuring and recording electrical activity resulting from thousands of simultaneous neural processes associated with different portions of the brain. EEG data is typically measured using a plurality of electrodes placed on the scalp of a user to measure voltage fluctuations resulting from this electrical activity within the neurons of the brain. Subcranial EEG can measure electrical activity with high accuracy. Although bone and dermal layers of a human head tend to weaken transmission of a wide range of frequencies, surface EEG also provides useful electrophysiological information.

BRIEF DESCRIPTION OF THE DRAWINGS

[0004] FIG. 1 illustrates a perspective view of an example headset having a plurality of adjustable bands in accordance with the teachings of this disclosure.

[0005] FIG. 2 is a right side view of the headset of FIG. 1.

[0006] FIG. 3 is a left side view of the headset of FIG. 1.

[0007] FIG. 4A is a perspective view of the headset of FIG. 1 in an example orientation.

[0008] FIG. 4B is a perspective view of the headset of FIG. 1 in another example orientation.

[0009] FIG. 5 is a perspective view of an example adjustable band or spine of the headset of FIG. 1.

[0010] FIG. 6 is an enlarged view of an end of the example spine of FIG. 5.

[0011] FIG. 7 is a cross-sectional view of the example spine of FIG. 5.

[0012] FIG. 8A is a circuit diagram for an example EEG system.

[0013] FIG. 8B is a circuit diagram for an example EEG system with wet electrodes.

[0014] FIG. 8C is a circuit diagram for an example EEG system with dry electrodes in accordance with the teachings of this disclosure.

[0015] FIG. 9 is a schematic view of a top of a head illustrating example electrode and ground placement locations.

[0016] FIG. 10 is an enlarged view of an example adjustment mechanism shown on the headset of FIG. 1.

[0017] FIG. 11A is a perspective view of an example electrode of FIGS. 1-7.

[0018] FIGS. 11B and 11C are front views of two alternative example electrode designs.

[0019] FIG. 11D is a perspective view of an example central electrode array plate.

[0020] FIG. 12A is a block diagram of an example switching circuit.

[0021] FIG. 12B is a graphical representation of averaging of multiple channels of data.

[0022] FIG. 13A is a cross-sectional view of an example electrode in contact with a scalp of a user.

[0023] FIG. 13B is a cross-section view of an alternative example electrode in contact with a scalp of a user.

[0024] FIG. 14 is a circuit diagram for an example electrode.

[0025] FIG. 15 is a perspective view of an alternative band or spine and an alternative electrode constructed in accordance with the teachings of this disclosure.

[0026] FIG. 16 is an exploded view of the example electrode of FIG. 15.

[0027] FIG. 17 is an exploded view of another example snap electrode constructed in accordance with the teachings of this disclosure.

[0028] FIG. 18 is a perspective view of another example electrode constructed in accordance with the teachings of this disclosure.

[0029] FIG. 19A is a perspective view of another example electrode constructed in accordance with the teachings of this disclosure.

[0030] FIG. 19B is a cross-sectional view of the example electrode of FIG. 19A.

[0031] FIG. 20 is a perspective view of an example mold used for manufacturing an example spine.

[0032] FIG. 21 is a perspective view of an example spine after manufacturing in the example mold of FIG. 20.

[0033] FIGS. 22A-22J are perspective views of a user's head and example areas for electrode contact.

[0034] FIG. 23 is a perspective view of another example headset constructed in accordance with the teachings of this disclosure and having a plurality of bands with electrode tips.

[0035] FIG. 24 is a bottom view of the example headset of FIG. 23 and a USB connection port.

[0036] FIG. 25 is a perspective view of the example headset of FIG. 23 on a USB base stand.

[0037] FIG. 26 is a back side view of the example headset of FIG. 23.

[0038] FIG. 27 is a top side view of the example headset of FIG. 23.

[0039] FIG. 28 is a right side view of the example headset of FIG. 23.

[0040] FIG. 29 is a bottom perspective view of the example headset of FIG. 23.

[0041] FIG. 30 illustrates an exploded view of example layers of an example headset.

[0042] FIG. 31 is an exploded view of the example circuit housing of FIG. 30.

[0043] FIGS. 32A-32D are exploded views of an example electrode connector used in the example headset of FIG. 23.

[0044] FIG. 33 is a side view of the example electrode connector of FIGS. 32A-32D in a partially assembled state.

[0045] FIG. 34 is a perspective view of another example headset constructed in accordance with the teachings of this disclosure.

[0046] FIG. 35 is a perspective view of an adjustment knob for the example headset of FIG. 34.

[0047] FIG. 36 is a block diagram of an example circuit from the headset in FIGS. 1, 23 and/or 34.

[0048] FIG. 37 is a block diagram of an example manner of implementing the processor and signal selector of FIGS. 1-7 and 12.

[0049] FIG. 38 is a block diagram of an example manner of implementing the headset(s) of FIGS. 1, 23 and/or 34 with additional physiological sensor systems.

[0050] FIG. 39 is a block diagram of an example manner of implementing the processing and conditioning of FIGS. 1, 23 and 34.

[0051] FIG. 40 is a flow chart representing an example method of analyzing EEG data in accordance with the teachings of this disclosure.

[0052] FIG. 41 is a flow chart representing an example method of improving EEG signal quality in accordance with the teachings of this disclosure.

[0053] FIG. 42 is a flow chart representing an example method of conducting at-home patient monitoring/treatment in accordance with the teachings of this disclosure.

[0054] FIG. 43 is a flow chart representing an example method of processing a user's attention to a media and desire to control a device in accordance with the teachings of this disclosure.

[0055] FIG. 44 is a flow chart representing an example method of gathering and analyzing electroencephalographic data in accordance with the teachings of this disclosure.

[0056] FIG. 45 illustrates an example processor platform that may execute one or more of the instructions of FIGS. 40-44 to implement any or all of the example methods, systems and/or apparatus disclosed herein.

DETAILED DESCRIPTION

[0057] Certain examples are shown in the above-identified figures and disclosed in detail below. In describing these examples, like or identical reference numbers are used to identify the same or similar elements. The figures are not necessarily to scale and certain features and certain views of the figures may be shown exaggerated in scale or in schematic for clarity and/or conciseness. Additionally, several examples have been described throughout this specification.

[0058] Biological cells and tissues have electrical properties that can be read, which provide information regarding the functioning of the cell or tissue. Various types of electrophysiological techniques have been developed to measure electrical signals from a body. For example, electrocardiography (ECG or EKG) measures electrical activity in a heart. Electroencephalography (EEG) measures electrical activity in a brain. Electrooculography (EOG) measures electrical activity using electrodes placed directly on an exposed surface of a brain to record electrical activity in a cerebral cortex. Electromyography (EMG) measures electrical activity in a muscle. Electrooculography (EOG) measures the resting potential of a retina, and electroretinography measures electrical responses of retinal cells. These and/or other electrophysiological signals are important in the treatment, diagnosis and monitoring of many health conditions.

[0059] EEG data is indicative of electrical activity of neurons including neural depolarization in the brain due to

stimuli of one or more of the five senses (evoked activity) as well as from thought processes (spontaneous activity) generates electrical activity in the brain. Summations of these electrical activities, (e.g., brainwaves), propagate to the surface and are detectable with electroencephalograms. Because the current flow in the human body is due to ion flow, a biopotential electrode is used, which forms an electrical double layer with the human skin to sense the ion distribution.

[0060] EEG data can be classified in various bands. Brain-wave frequencies include delta, theta, alpha, beta and gamma frequency ranges. Delta waves are classified as those less than about 4 Hertz (Hz) and are prominent during sleep. Theta waves have frequencies between about 3.5 Hz to about 7.5 Hz and are associated with memories, attention, emotions, and sensations. Theta waves are typically prominent during states of internal focus. Alpha frequencies reside between about 7.5 Hz and about 13 Hz and typically peak around 10 Hz. Alpha waves are prominent during states of relaxation. Beta waves have a frequency range between about 14 Hz and about 30 Hz. Beta waves are prominent during states of motor control, long range synchronization between areas, analytical problem solving, judgment, and decision making. Gamma waves occur between about 30 Hz and about 100 Hz and are involved in binding of different populations of neurons together into a network for the purpose of carrying out a certain cognitive or motor function, as well as in attention and memory. Because the skull and dermal layers attenuate waves in this frequency range, brain waves above about 75 Hz (e.g., high gamma band or kappa band) are less easily measured than waves in lower frequency bands. EEG data may be used to determine an emotional or mental state of a person including, for example, attention, emotional engagement, memory or resonance, etc.

[0061] EEG signals may be measured using a plurality of electrodes placed on a scalp of a person (e.g., a user, a viewer, a subject, a panelist, a participant or a patient) to measure voltage fluctuations resulting from electrical activity associated with post synaptic currents occurring in the milliseconds range within neurons of a brain. Though subcranial EEG can measure electrical activity with high accuracy, surface electrodes such as, for example, dry electrodes also provide useful neuro-response information.

[0062] Many traditional EEG electrodes suffer from high impedance and/or require messy gels to increase signal quality. In addition, many known EEG headsets utilize a helmet or head-strap type assembly that include a limited number of electrodes. These known headsets are uncomfortable to wear and typically cannot effectively accommodate a variety of differently sized heads.

[0063] To enable the surface EEG electrodes to effectively receive signals from the brain, the electrodes are to be placed as close to the scalp as possible. The electrodes may be manually placed upon a subject's head or may be contained in a wearable apparatus such as, for example, a headset. However, a subject's hair may interfere with the contact between an electrode and the scalp by limiting the surface area contact of the electrode. For example the average person tends to have from about 80 to about 200 hair follicles per square centimeter (follicles/cm²). The hair strands and the hair follicles that are interposed between the electrode and the scalp raise impedance several mega-Ohms (Me). EEG systems with impedances greater than 100 kilo-Ohms (k Ω) are vulnerable to various sources of noise that obscure the reading of the EEG signal. Impedance can be reduced by applying pressure

to the electrodes thus decreasing the distance between the electrodes and the tissue of the scalp. However, too much pressure such as, for example, greater than two Newtons per millimeter square (N/mm^2) results in discomfort for the subject. In some examples, the pressure slightly compresses the underlying stratum corneum, which is the outermost layer of the epidermis, for example the outermost 10-40 micrometers (μm). Known EEG sensors do not account for the thickness of one or more strands of hair or hair follicles and do not effectively adjust to a specific size of a user head and, thus, known systems cannot apply an effective amount of pressure against the scalp. In some examples disclosed herein, a profile of the electrode including the electrode tip is designed to achieve both comfort and noise reduction. In addition, in examples disclosed herein, a headset into which the electrodes are incorporated is modularly adjustable also to enhance comfort and noise reduction, as disclosed in greater detail below.

[0064] Because of the very low signal amplitude of EEG data and high impedances, noise is a significant factor to consider in high quality EEG instruments. Noise types are classifiable by the various sources of the noise such as, for example, skin potential noise, thermal noise, amplifier noise, electrode noise and interference noise.

[0065] Skin potential noise relates to stretching of the skin that causes a change of the potential at the electrode. Examples disclosed herein mitigate skin potential noise by utilizing special electrode shape(s) such that the pressure imparted by the electrodes onto the scalp reduces skin potential noise. Because the skin is stretched and pressed by the example electrodes described herein, there is less noise in general and less noise when the subject moves. An optimized pressure imparted by the electrodes onto the scalp decreases skin potential noise while increasing comfort. An example pressure is less than about $2 \text{ N}/\text{mm}^2$.

[0066] Thermal noise is electronic noise generated by thermal agitation of charge carrying electronic components. Thermal noise is proportional to the impedance and bandwidth and may be represented by the equation: $V_{TH} = (4 kTBR)^{1/2}$, where k is the Boltzman constant, T is temperature in Kelvins (K), B is the bandwidth in Hertz, and R is the electrode impedance in Ohms (Ω). For example, with a target impedance of $1 \text{ M}\Omega$ at room temperature ($T=300\text{K}$) and 150 Hz bandwidth, the thermal noise will be about 1 micro-volt root-mean-square (μVrms). Averaging over a number independently digitized electrodes, n , improves the signal-to-noise ratio by about $1/(n)^{1/2}$ (e.g., see FIG. 12B). As disclosed in greater detail below, an electrode shape with an effective diameter below 0.2 millimeter (mm) allows up to about 100 independent digitized electrodes in an area having a diameter of about less than 15 mm. In some example EEG systems, there is a spatial resolution at the surface of the scalp of a maximum of about 15 mm. The examples disclosed herein mitigate thermal noise by averaging readings over multiple electrodes such as, for example, averaging with $n=100$ electrodes by a factor of 10.

[0067] Amplifier noise is noise intrinsic to the amplification process. Amplifier noise is typically small such as, for example, around $0.5 \mu\text{Vrms}$ at a bandwidth of about 150 Hz. The examples disclosed herein mitigate amplifier noise by averaging readings over multiple electrodes, thereby canceling at least a portion of the noise out. Averaging over n number of independently digitized electrodes improves the signal-to-noise ratio by about $1/(n)^{1/2}$ (e.g., see FIG. 12B, thus taking into account both thermal noise and amplifier noise).

Also, as described above, with the example electrode shape disclosed below, which has an effective diameter below 0.2 mm, with more than 100 independent digitized electrodes in an area having a diameter of less than about 15 mm, and with a spatial resolution at the surface of the scalp of maximum about 15 mm, the examples disclosed herein also mitigate amplifier noise by averaging readings over multiple electrodes such as, for example, by averaging with $n=100$ electrodes by a factor of 10.

[0068] Interference noise exists due to the presence of external electromagnetic fields (e.g. power lines). Electro-magnetic induced noise can penetrate the EEG signal over several pathways. For example, an electric field can induce displacement current into the electrode leads, the electrode-skin interface or individual components of the EEG device (e.g. amplifier, power supplies, etc). Another source of electromagnetic noise is the common mode voltage on the subject's body (V_c), which is composed of a static voltage component (V_s) and a power-line-induced component (V_a). The power-line-induced component (V_a) is caused by a displacement current (I_d), which flows through stray capacitance (C_d). The size of this capacitance is determined by the proximity of the subject is to power sources. The power-line-induced component (V_a) can be as large as 20V, for example, if the subject grasps an insulated power cord. Friction creates a charge that is stored in capacitance between the body and ground (C_b). For example, a third person who is charged in this way can induce a static voltage into the subject if he/she moves close to the subject. The examples disclosed herein enable the encapsulation of the EEG signal from external electromagnetic fields, which enhances the robustness of the EEG signal against electromagnetic noise sources. In some disclosed examples, a faraday cage is established around the EEG system to decouple the EEG system from environmental noise. Also, a dedicated shielding electrode with low impedance connection ($Z_{sh} < 100 \text{ k}\Omega$) to the subject's body ensures that no displacement current penetrates the system.

[0069] Example headset devices and accompanying components for receiving neuro-response data from a user's head are disclosed herein. An example headset disclosed herein is portable and comprises a plurality of independently adjustable bands operatively coupled to a first housing encasing a processor on one end and a second housing including an adjustment mechanism on the other end.

[0070] Example headsets described herein adapt to any head shape while also applying adequate force to each of a plurality of electrodes (e.g., dry electrodes) that are coupled to the headset to provide excellent EEG readings. Some such example headsets provide a simple, cost effective and reliable solution for the use of a large number of dry electrodes. Some such example headsets ensure comfort, good electrode contact, through the hair operation, and shielding against line noise and other type(s) of noise. Examples disclosed herein also include independently adjustable components to enhance comfort and wearability. In addition, examples disclosed herein greatly increase the number of channels (e.g., electrodes) capable of gathering signals from the head, which as detailed below, enhances data gathering and analysis.

[0071] An example device is disclosed herein that includes a first elongated band coupled to a first housing to be located near a first ear of a subject and a second housing to be located near a second ear of the subject, the first elongated band comprising a first set of electrodes. The example device also includes a second elongated band coupled to the first housing

and to the second housing, the second elongated band comprising a second set of electrodes. In addition, the device includes a third elongated band coupled to the first housing and to the second housing, the third elongated band comprising a third set of electrodes, and a fourth elongated band coupled to the first housing and to the second housing, the fourth elongated band comprising a fourth set of electrodes. Other example devices include fewer or more adjustable bands including, for example three, two, one, five, etc.

[0072] In some examples, each of the first, second, third and fourth elongated bands is rotatably coupled to each of the first housing and the second housing. In some examples, each of the first, second, third and fourth elongated bands is removably coupled to each of the first housing and the second housing.

[0073] In some examples, the first elongated band is to be located above a nasion (e.g., the intersection of the frontal bone and two nasal bones) of the subject at about ten percent of a distance between the nasion and an inion (e.g., the projection of the occipital bone) of the subject measured over a center of a head of the subject, the second elongated band is to be located above the nasion at about thirty percent of the distance, the third elongated band is to be located at about halfway between the nasion and the inion and the fourth elongated band is to be located above the inion at about thirty percent of the distance.

[0074] In some examples, a sum of the number of electrodes in the first, second, third and fourth electrode sets comprises at least 2000 electrodes. In some examples, the number of electrodes or channels could be 3000 electrodes or more. Also, in other examples, where less data channels are needed or desired, there may be fewer electrodes.

[0075] In some examples, each of the first, second, third and fourth elongated bands include an adjustable elastic band or strap to change a distance between the elongated band and a head of the subject.

[0076] In some examples, the device also includes one or more additional elongated bands, each additional elongated band coupled to the first housing and the second housing and each additional elongated band comprising respective additional sets of electrodes.

[0077] In some examples, the device includes an adjustment mechanism coupled to the first housing and/or the second housing to adjust a fit of the device on the subject.

[0078] In some examples, the first elongated band comprises a plurality of extensions and the plurality of electrodes of the first set are individually disposed at respective ends of the extensions. In some examples, the extensions are flexible.

[0079] In some examples disclosed herein, the electrodes comprise at least a portion of a ring. In some examples, the electrodes comprise a ball. In some examples, the electrodes comprise a hook. In some examples, the electrodes comprise a pin.

[0080] In some examples, the electrodes are removably coupled to the respective first, second, third or fourth elongated band.

[0081] In some examples, one or more of the electrodes is to compress a stratum corneum of the subject at a force of about 1 N/mm² to about 2 N/mm².

[0082] In some examples, the disclosed device includes an analog-to-digital converter to convert signals gathered by the electrodes to digital data, an amplifier to amplify the signals, and a signal conditioner to remove noise from the signals. Some such example devices also include a data processor to

analyze the data in accordance with one or more analysis protocols to determine a mental state of the subject and a transmitter to transmit at least one of the digital data or the mental state.

[0083] In some examples, the device is to be worn on a head of the subject.

[0084] Also disclosed herein are example methods that include obtaining electroencephalographic data from a device comprising a first elongated band coupled to a first housing to be located near a first ear of a subject and a second housing to be located near a second ear of the subject, the first elongated band comprising a first set of electrodes having at least eight electrodes and a second elongated band coupled to the first housing and to the second housing, the second elongated band comprising a second set of electrodes having at least eight electrodes. Some devices used in some such example methods include a third elongated band coupled to the first housing and to the second housing, the third elongated band comprising a third set of electrodes having at least eight electrodes and a fourth elongated band coupled to the first housing and to the second housing, the fourth elongated band comprising a fourth set of electrodes having at least eight electrodes. Some such example methods further include analyzing the electroencephalographic data to determine a mental state of the subject.

[0085] Some example methods include converting the electroencephalographic data gathered from the electrodes to digital data, amplifying the electroencephalographic data and removing noise from the electroencephalographic data. Other example methods include analyzing the data in accordance with one or more analysis protocols to determine the mental state of the viewer and/or transmitting at least one of the digital data or the mental state.

[0086] Also disclosed herein is a tangible machine readable storage medium comprising instructions which, when read, cause a machine to at least obtain electroencephalographic data from a device comprising a first elongated band coupled to a first housing to be located near a first ear of a subject and a second housing to be located near a second ear of the subject, the first elongated band comprising a first set of electrodes having at least eight electrodes and a second elongated band coupled to the first housing and to the second housing, the second elongated band comprising a second set of electrodes having at least eight electrodes. Some such example devices also include a third elongated band coupled to the first housing and to the second housing, the third elongated band comprising a third set of electrodes having at least eight electrodes and a fourth elongated band coupled to the first housing and to the second housing, the fourth elongated band comprising a fourth set of electrodes having at least eight electrodes. Some example instructions cause a machine to analyze the electroencephalographic data to determine a mental state of the subject.

[0087] Some example instructions cause a machine to convert the electroencephalographic data gathered from the electrodes to digital data, amplify the electroencephalographic data, and remove noise from the electroencephalographic data. Some instructions cause a machine to analyze the data in accordance with one or more analysis protocols to determine the mental state and transmit at least one of the digital data or the mental state.

[0088] An example device disclosed herein includes a central body portion such as, for example, a spine and a plurality of extensions extending from the central body portion, each

extension having an end coupled to an electrode. The example device also includes an adjustment band disposed along a longitudinal axis of the central body to adjust a position of the extensions.

[0089] In some examples, the adjustment band is elastic. Also, in some examples, the adjustment band has a circular cross section. In other examples, the adjustment band has a rectangular cross section. In some examples, the adjustment band is slidably disposed along the longitudinal axis.

[0090] In some examples disclosed herein, the central body portion comprises a first protrusion, a second protrusion, and a recess formed between the first protrusion and the second protrusion, and the adjustment band is disposed in the recess. In some examples, the central body portion and the extensions comprises one or more of silicone or rubber. Also, in some disclosed examples, the device includes a flexible printed circuit board encapsulated in the central body portion and extensions.

[0091] In some examples, each of the extensions is curved in a direction away from the central body portion. In some such examples, each of the extensions is curved in the same direction. Furthermore, in some examples, a first extension is located directly across the central body portion from a second extension. In some examples, the central body portion and the extensions are flexible but not elastic and the adjustment band is flexible and elastic.

[0092] In some examples, the electrodes are resilient (e.g., springy). Also, in some examples, the electrodes are removable. In some examples, the example electrodes comprise at least a portion of a ring. The example device also includes, in some examples, an array of electrodes disposed on one side of the central body portion. In some examples, the array is an embossed plate and the device includes up to 256 electrodes.

[0093] In some examples, a tightening of the adjustment band causes the electrodes to apply a force to a head of a subject wearing the device. In some examples, the force is approximately the same at each electrode.

[0094] In some examples the disclosed device includes a silver nylon coating.

[0095] Some example devices disclosed herein include an analog-to-digital converter to convert a signal obtained from an electrode to a digital signal. Also, some example devices include a signal conditioner to at least one of amplify a signal obtained from an electrode or remove noise from the signal.

[0096] In some examples, the device includes a cover partially surrounding an electrode so that a first portion of the cover is disposed on a first side of the electrode, a second portion of the cover is disposed on a second side of the electrode, and an end of the electrode to contact a tissue of a subject extends from the cover. In some examples, the electrode has a cross section of less than about 0.5 mm, a first outer end of the first portion of the cover and a second outer end of the second portion of the cover are separated by a distance of about less than 1 mm, and the end of the electrode to contact the tissues extends about less than 0.2 mm from the cover.

[0097] Another example method disclosed herein includes obtaining electroencephalographic data from a device worn by a subject, the device comprising a central body portion and a plurality of extensions extending from the central body portion, each extension having an end coupled to an electrode. The device of some such example methods also includes an adjustment band disposed along a longitudinal axis of the central body to adjust a position of the extensions.

Some such example methods also include analyzing the data to determine a mental state of the subject.

[0098] Some example methods also include one or more of converting a signal obtained from an electrode to a digital signal, amplifying a signal obtained from an electrode and/or removing noise from the signal.

[0099] Another example tangible machine readable storage medium disclosed herein includes instructions which, when read, cause a machine to at least obtain electroencephalographic data from a device worn by a subject. The device of some such example instructions includes a central body portion, a plurality of extensions extending from the central body portion, each extension having an end coupled to an electrode and an adjustment band disposed along a longitudinal axis of the central body to adjust a position of the extensions. Some example instructions further cause a machine to analyze the data to determine a mental state of the subject.

[0100] Some example instructions further cause the machine to one or more of convert a signal obtained from an electrode to a digital signal, amplify a signal obtained from an electrode and/or remove noise from the signal.

[0101] Some example devices disclosed herein includes a first band comprising a first set of electrodes and a second band comprising a second set of electrodes. In some examples, the first band and the second band are to be oriented in a first direction to obtain first neuro-response data from a subject, and the first band and second band are to be oriented in a second direction to obtain second neuro-response data from the subject, the second direction being substantially orthogonal to the first.

[0102] In some examples, the first band has a first end and a second end, the second band has a third end and a fourth end, the first end is coupled to the third end, and the second end is coupled to the fourth end. Also, in some examples, the first end is coupled to the third end through a first housing and the second end is coupled to the fourth end through a second housing. In some examples, the second housing includes a processor to analyze data collected from the electrodes. In addition, in some examples, the first housing includes an adjustment mechanism to adjust a fit of the device on the subject.

[0103] In some examples, the device is to be oriented in the second direction to gather a midline reading from a brain of the subject.

[0104] Other example methods disclosed herein include obtaining first neuro-response data from a subject with a device oriented in a first direction. The device of some such example methods includes a first band comprising a first set of electrodes and a second band comprising a second set of electrodes. The example methods also include obtaining second neuro-response data from the subject with the device oriented in a second direction, the second direction approximately orthogonal to the first.

[0105] Some examples methods also include analyzing the data gathered from the electrodes using a processor disposed in a second housing. Also, some examples methods include gathering a midline reading from a brain of the subject with the device in the second direction.

[0106] Also disclosed herein is a tangible machine readable storage medium comprising instructions which, when read, cause a machine to at least obtain first neuro-response data from a subject with a device oriented in a first direction, the device comprising a first band comprising a first set of electrodes and a second band comprising a second set of elec-

trodes. Some example instructions further cause the machine to obtain second neuro-response data from the subject with the device oriented in a second direction, the second direction orthogonal to the first.

[0107] Some example instructions further cause the machine to analyze the data gathered from the electrodes using a processor disposed in a second housing. Some example instructions further cause the machine to gather a midline reading from a brain of the subject with the device in the second direction.

[0108] Also disclosed herein are example devices that include a first set of electrodes to read an electrical signal from a tissue of a subject and a second set of electrodes to read the electrical signal. In such examples, the first set and the second set of electrodes are mechanically coupled to a headset. In addition, in the example devices, the first set of electrodes comprises a first type of electrodes, and the second set of electrodes comprises a second type of electrodes, different than the first type.

[0109] In some examples, the first type of electrodes comprises individually mounted electrodes, and the second type of electrodes includes an array of electrodes. In some examples, two or more of the electrodes in the array can be electrically shorted to form one electrode with an increased surface area. Also, in some examples, the first type of electrode comprises at least one of a partial ring, a ball point and/or a hook. In addition, in some examples, the first set is disposed along a first outer side of an elongated band and along a second outer side of the elongated band and the second set is disposed along a center axis of the elongated band.

[0110] Some example methods disclosed herein include reading an electrical signal from a tissue of a subject using a first set of electrodes. Some such example methods also include reading the electrical signal using a second set of electrodes, wherein the first set and the second set of electrodes are mechanically coupled to a headset and the first set of electrodes comprises a first type of electrodes and the second set of electrodes comprises a second type of electrodes, different than the first type.

[0111] Also disclosed herein is a tangible machine readable storage medium comprising instructions which, when read, cause the machine to at least read an electrical signal from a tissue of a subject using a first set of electrodes and read the electrical signal using a second set of electrodes. The first set and the second set of electrodes used with such example instructions are mechanically coupled to a headset and the first set of electrodes comprises a first type of electrodes and the second set of electrodes comprises a second type of electrodes, different than the first type.

[0112] Some example devices disclosed herein include a first housing comprising a magnetic lock. Some such example devices also include a first elongated band having a first end adjustably coupled to the first housing. The first elongated band comprises a first plurality of electrodes. Some such example devices also include a first adjustable strap. The first adjustable strap comprises a first magnetic fastener to magnetically link with the magnetic lock at a first engagement point to secure the first elongated band in a first position and to magnetically link with the magnetic lock at a second engagement point to secure the first elongated band in a second position.

[0113] In some examples, the device is to be worn on a head of a subject, wherein the first position is closer to a top of the

head than the second position and adjustment of the first magnetic fastener from the first position to the second position tightens the first elongated band and brings the electrodes closer to the head. In some examples, the first elongated band is removably coupled to the first housing.

[0114] Some such example devices also include a second elongated band having a second end adjustably coupled to the first housing. The second elongated band comprises a second plurality of electrodes. Some such example devices also include a second adjustable strap. The second adjustable strap comprises a second magnetic fastener to magnetically link with the magnetic lock at a third engagement point to secure the second elongated band in a third position and to magnetically link with the magnetic lock at a fourth engagement point to secure the second elongated band in a fourth position.

[0115] In some examples, the first elongated band and second elongated band are independently adjustable. Also, in some examples, the first elongated band and the second elongated band are independently removable.

[0116] Other methods disclosed herein include releasing a first magnetic fastener of an adjustable strap of a first elongated band of a device from a first engagement point with a magnetic lock of a first housing to unlock the first elongated band from a first position. Some such example methods also include coupling the first magnetic fastener to the magnetic lock at a second engagement point to secure the first elongated band in a second position.

[0117] Some examples methods include releasing a second magnetic fastener of an adjustable strap of a second elongated band of a device from a third engagement point with the magnetic lock to unlock the second elongated band from a third position. Some example methods also include coupling the second magnetic fastener to the magnetic lock at a fourth engagement point to secure the second elongated band in a fourth position.

[0118] Also, some example methods include one or more of independently adjusting the first elongated band and second elongated band and/or independently removing the first elongated band and the second elongated band.

[0119] Some example devices disclosed herein include a first hub and a first removable band comprising a first plurality of electrodes removably coupled to the first hub. In some such examples, the first band comprises a first cover comprising at least one of nylon or silver. The first band is washable in an automated washing machine. In some examples, the cover is stretchable. In some examples, the device includes a second removable, washable band comprising a second plurality of electrodes. Also, in some examples, the first removable band is adjustably coupled to the first hub and usable for a first subject having a first head size and a second subject having a second head size, the second head size different than the first head size.

[0120] Some example methods disclosed herein include removing a first removable band comprising a first plurality of electrodes from a first hub, the first band comprising a first cover comprising at least one of nylon or silver. Some such example methods also include washing the first band in an automated washing machine. Also, some example methods include removing a second removable, washable band comprising a second plurality of electrodes from the first hub and washing the second band in the automated washing machine. In addition, some example methods include adjusting the first removable band relative to the first hub to fit a first subject having a first head size and/or readjusting the first removable

band relative to the first hub to fit a second subject having a second head size, the second head size different than the first head size.

[0121] Some example methods disclosed herein include obtaining electroencephalographic (EEG) data from a subject via a device comprising two or more independently adjustable bands, each of the bands having a plurality of electrodes to detect the electroencephalographic data from a brain of the subject, each band selectively rotatable relative to an adjacent band and each band selectively compressible to increase a force of the electrodes against a head of the subject. Some such example methods include converting the EEG data into digital EEG signals and conditioning the digital EEG signals. In addition, some such example methods include analyzing the digital EEG signals using one or more analysis protocols to determine a mental characteristic of the subject and transmitting the mental characteristic to an output device.

[0122] In some example methods, the device further comprises a processor to perform the converting, the conditioning, the analyzing and the transmitting. In some examples, the converting is to occur at each of the electrodes. In some examples, the device comprises at least 2000 electrodes.

[0123] In some example methods, the device comprises a wireless transmitter to transmit the mental characteristic. In some examples, the conditioning comprises at least one of amplifying the digital EEG signals or filtering the digital EEG signals.

[0124] In some examples, the output device comprises one or more of a handheld device, an alarm, a display screen on the device, a remote server or a remote computer. In some example methods, the output device is to at least one of sound an alarm, display a message, present an alert on a screen, issue a report to a local computer or issue a report to a remote computer. Also, in some examples, the mental characteristic comprises one or more of a mental state, a health condition, a physiological state, an attention level, a resonance level, a memory attribute or an emotional engagement indicator.

[0125] Also disclosed herein is a tangible machine accessible storage medium comprising instructions that, when executed, cause a machine to at least obtain electroencephalographic (EEG) data from a subject wearing a device, the device comprising two or more independently adjustable bands, each of the bands having a plurality of electrodes to detect the electroencephalographic data from a brain of the subject, each band selectively rotatable relative to an adjacent band and each band selectively compressible to increase a force of the electrodes against a head of the subject. In example instructions also cause the machine to convert the EEG data into digital EEG signals, condition the digital EEG signals, analyze the digital EEG signals using one or more analysis protocols to determine a mental characteristic of the subject and transmit to mental characteristic to an output device. In some examples, the storage medium is disposed within the device.

[0126] Some example systems disclosed herein include a device to obtain electroencephalographic (EEG) data from a subject, the device comprising two or more independently adjustable bands, each of the bands having a plurality of electrodes to detect the electroencephalographic data from a brain of the subject, each band selectively rotatable relative to an adjacent band and each band selectively compressible to increase a force of the electrodes against a head of the subject. The example system also includes an analog-to-digital converter to convert the EEG data into digital EEG signals and a

signal conditioner to condition the digital EEG signals. Some such example systems also include a processor to analyze the digital EEG signals using one or more analysis protocols and determine a mental characteristic of the subject and a transmitter to transmit the mental characteristic to an output device.

[0127] In some example systems, the analog-to-digital converter, the signal conditioner, the processor and the transmitter are disposed on the device. Some example systems include an analog-to-digital converter at each of the electrodes. Some example systems further include a signal conditioner at each of the electrodes. Some example systems include a detrending unit to compensate for polarization of the electrodes.

[0128] An example method disclosed herein includes evaluating a first property of a first neurological signal, determining if the first neurological signal complies with a quality threshold based on the first property, evaluating a second property of a second neurological signal and determining if the second neurological signal complies with the quality threshold based on the second property. The example method also includes conditioning the first neurological signal if the first neurological signal does not comply with the quality threshold to obtain a third neurological signal and conditioning the second neurological signal if the second neurological signal does not comply with the quality threshold to obtain a fourth neurological signal. In addition, the example method includes evaluating a third property of the third neurological signal, determining if the third neurological signal complies with the quality threshold based on the third property, evaluating a fourth property of the fourth neurological signal and determining if the fourth neurological signal complies with the quality threshold based on the fourth property. The example method also includes selecting, based on respective compliance with the quality threshold, a first one of the first neurological signal, the second neurological signal, the third neurological signal or the fourth neurological signal to at least one of use for additional analysis, to ignore, or to merge with a second one of the first neurological signal, the second neurological signal, the third neurological signal or the fourth neurological signal.

[0129] In some examples, the method occurs on a headset device used to gather the first neurological signal and the second neurological signal. In some examples, the first, second, third and fourth properties comprise at least one of a strength, an amplitude, a signal-to-noise ratio or a duration of the respective first, second, third or fourth neurological signal.

[0130] In some example methods, the compliance with the quality threshold is based on a comparison of the first, second, third or fourth neurological signal to a reference value. In some such examples, the reference value comprises an absolute threshold, a spectral threshold, a ramp-rate threshold or a low-activity threshold.

[0131] In some example methods, the conditioning comprises at least one of amplifying the first or second neurological signal or filtering the first or second neurological signal. In some examples, the ignoring or the merging is conducted by a switching circuit communicatively coupled to a first channel through which the first neurological signal is gathered and a second channel through which the second neurological signal is gathered.

[0132] Also disclosed herein is a tangible machine accessible storage medium comprising instructions that, when executed, cause a machine to at least evaluate a first property

of a first neurological signal, determine if the first neurological signal complies with a quality threshold based on the first property, evaluate a second property of a second neurological signal and determine if the second neurological signal complies with the quality threshold based on the second property. The example instructions also cause the machine to condition the first neurological signal if the first neurological signal does not comply with the quality threshold to obtain a third neurological signal, condition the second neurological signal if the second neurological signal does not comply with the quality threshold to obtain a fourth neurological signal, evaluate a third property of the third neurological signal, determine if the third neurological signal complies with the quality threshold based on the third property, evaluate a fourth property of the fourth neurological signal and determine if the fourth neurological signal complies with the quality threshold based on the fourth property. In addition, the instruction further cause the machine to select, based on respective compliance with the quality threshold, a first one of the first neurological signal, the second neurological signal, the third neurological signal or the fourth neurological signal to at least one of use for additional analysis, to ignore, or to merge with a second one of the first neurological signal, the second neurological signal, the third neurological signal or the fourth neurological signal.

[0133] In some examples, the storage medium is disposed within a headset device used to gather the first neurological signal and the second neurological signal. In some examples, the instructions further cause the machine to condition one or more of the first neurological signal or the second neurological signal by at least one of amplifying the first or second neurological signal or filtering the first or second neurological signal.

[0134] In some examples, the instructions further cause the machine to ignore one or more of the first, second, third or fourth neurological signals or merge two or more of the first, second, third or fourth neurological signals by actuating a switching circuit communicatively coupled to a first channel through which the first neurological signal is gathered and a second channel through which the second neurological signal is gathered.

[0135] An example system is disclosed herein that includes a headset device to gather a first neurological signal and a second neurological signal from a brain of a subject. The example system also includes a processor to evaluate a first property of the first neurological signal, determine if the first neurological signal complies with a quality threshold based on the first property, evaluate a second property of the second neurological signal and determine if the second neurological signal complies with the quality threshold based on the second property. In the example system, the processor is to condition the first neurological signal if the first neurological signal does not comply with the quality threshold to obtain a third neurological signal, condition the second neurological signal if the second neurological signal does not comply with the quality threshold to obtain a fourth neurological signal, evaluate a third property of the third neurological signal, determine if the third neurological signal complies with the quality threshold based on the third property, evaluate a fourth property of the fourth neurological signal and determine if the fourth neurological signal complies with the quality threshold based on the fourth property. In the example system, the processor is also to select, based on respective compliance with the quality threshold, a first one of the first neurological

signal, the second neurological signal, the third neurological signal or the fourth neurological signal to at least one of use for additional analysis, to ignore, or to merge with a second one of the first neurological signal, the second neurological signal, the third neurological signal or the fourth neurological signal.

[0136] In some examples, the system includes a switching circuit selectively communicatively coupled to a first channel to gather the first neurological signal and selectively communicatively coupled to a second channel to gather the second neurological signal to at least one of ignore one or more of the first, second, third or fourth neurological signals or merge two or more of the first, second, third or fourth neurological signals.

[0137] Some example methods disclosed herein include monitoring activity of a patient in a home environment and analyzing first data gathered from a first sensor coupled to the patient to determine a first characteristic of the patient, the first sensor comprising an electrode coupled to a head of the patient. The example method also includes analyzing second data gathered from a second sensor coupled to the patient to determine a second characteristic of the patient, determining a health assessment of the patient based on the activity, the first characteristic and the second characteristic and producing an output signal based on the health assessment.

[0138] In some example methods, the second data is to be wirelessly transmitted to a device housing the first sensor. In some examples, the second sensor comprises one or more of a biometric sensor, a neurological sensor or a physiological sensor. In some examples, the second sensor comprises an electrocardiogram, a glucose monitoring system, an electrooculography system, a facial monitoring system or a plug-in/plug-and-play device. In some example methods, the second sensor comprises an eye-tracking sensor, a galvanic skin response sensor, an electromyography instrument, a camera, an infrared sensor, an interaction speed detector or a touch sensor. In some examples, the second sensor comprises a full facial or hemi-facial coverage camera.

[0139] Some example methods further include comparing the health assessment to a reference assessment and transmitting at least one of the health assessment or the output signal to a remote facility. In some such examples, the remote facility comprises at least one of a doctor's office, a hospital, a clinic, a laboratory, an archive, a research facility or a diagnostics facility.

[0140] In some example methods, the output signal is to be coupled to an alarm. In some such examples, the alarm comprises at least one of a light, a sound or a display. In some examples, the output signal is to activate an auto-delivery apparatus to automatically administer medication to the patient. Some example methods further include prompting the patient for an input based on the health assessment.

[0141] Some example methods further comprising tracking a location of a patient via a global positioning system (GPS) device. In some such examples, the GPS device is disposed within a device housing the first sensor. Some example methods further include logging the health assessment over a period of time.

[0142] Disclosed herein is a tangible machine accessible storage medium comprising instructions that, when executed, cause a machine to at least monitor activity of a patient in a home environment and analyze first data gathered from a first sensor coupled to the patient to determine a first characteristic of the patient, the first sensor comprising an electrode coupled

to a head of the patient. The instructions also cause the machine to analyze second data gathered from a second sensor coupled to the patient to determine a second characteristic of the patient, determine a health assessment of the patient based on the activity, the first characteristic and the second characteristic and produce an output signal based on the health assessment.

[0143] An example system is disclosed herein that includes a first sensor to gather first data from a patient, the first sensor comprising an electrode coupled to a head of the patient and a second sensor to gather second data from a patient, the second sensor coupled to the patient. The example system also includes a processor to monitor activity of the patient in a home environment, analyze the first data gathered from the first sensor to determine a first characteristic of the patient, analyze the second data gathered from the second sensor to determine a second characteristic of the patient, determine a health assessment of the patient based on the activity, the first characteristic and the second characteristic and produce an output signal based on the health assessment.

[0144] An example method disclosed herein includes analyzing first data gathered from a first sensor of a headset coupled to a subject while exposed to media to determine a first behavior of the subject, the first sensor comprising an electrode coupled to a head of the subject and determining a mental state of the subject based on the first behavior. The example method also includes analyzing second data gathered from a second sensor to determine a second behavior of the subject and determining an intended activity of the subject based on the mental state and the second behavior.

[0145] In some example methods, the first behavior is a change in brain activity. In some examples, the second behavior is a direction of eye gaze. In some examples, the mental state is a level of engagement.

[0146] In some example methods, the intended activity is an actuation of an electronic device. In some such examples, the actuation of the electronic device is a change in at least one of a volume, a mute status, a channel or a power status of a device presenting the media. In some examples, the actuation of the electronic device is a cursor move, a key stroke or a mouse click. Some example methods further include sending, from the headset, a signal to the electronic device to effectuate the intended activity.

[0147] In some example methods, the analysis of the first data comprises analyzing electroencephalographic signatures in a somatosensory system that are focal over a sensorimotor cortex contralateral to movement and include changes in mu and beta frequencies.

[0148] In some examples, the intended activity is consumption of the media. Some such example methods further include identifying a program in the media by at least one of detecting a channel, collecting an audio code indicative of the program or reviewing time-stamped data at a remote data collection facility. Other examples include determining an audience rating based on the intended activity and the program identification.

[0149] Disclosed herein is a tangible machine accessible storage medium comprising instructions that, when executed, cause a machine to at least analyze first data gathered from a first sensor of a headset coupled to a subject while exposed to media to determine a first behavior of the subject, the first sensor comprising an electrode coupled to a head of the subject and determine a mental state of the subject based on the first behavior. The instructions also cause the machine to

analyze second data gathered from a second sensor to determine a second behavior of the subject and determine an intended activity of the subject based on the mental state and the second behavior.

[0150] An example system is disclosed herein that includes a first sensor to gather first data, the first sensor disposed in a headset coupled to a subject while the subject is exposed to media, the first sensor comprising an electrode coupled to the head of the subject and a second sensor to gather second data from the subject. The example system also includes a processor to analyze the first data gathered from the first sensor to determine a first behavior of the subject, determine a mental state of the subject based on the first behavior, analyze the second data gathered from the second sensor to determine a second behavior of the subject and determine an intended activity of the subject based on the mental state and the second behavior.

[0151] Some example methods disclosed herein include placing a headset on a head of a user in a first orientation, the headset comprising one or more independently adjustable bands to be disposed on a head of a user, each band having a plurality of electrodes to receive electrical signals from a brain of the user. The method also includes adjusting a location of the electrodes on the user's head by selectively rotating one or more bands relative to respective adjacent bands and adjusting a compression of the electrodes on the user's head by selectively changing an effective length of respective elastic straps associated with the respective bands to change a force of the electrodes against the head. In addition, the example method includes obtaining electroencephalographic (EEG) data from the electrodes, conditioning the electroencephalographic data and analyzing the electroencephalographic data to determine a mental state of the user.

[0152] In some example methods, the conditioning comprises one or more of converting the signals to digital signals, amplifying the signals or filtering the signals. In some examples, the conditioning occurs in the headset. Some example methods further include assessing a quality of the electroencephalographic data obtained from the electrodes and determining if an electrode location is to be adjusted based on the quality.

[0153] Some example methods also include adjusting the location of the electrodes comprises physically moving one or more of the electrodes. Some such example methods further include rotating one or more of the bands to a second orientation on the head of the user.

[0154] In some examples, adjusting the location of the electrodes comprises virtually moving one or more of the electrodes. Some such examples further include shorting a portion of the plurality of electrodes when the quality of the EEG data obtained from those electrodes is below a threshold quality.

[0155] Some example methods further include outputting a signal to one or more of a medical system, an audience measurement facility or a remote device based on the mental state.

[0156] Disclosed herein is a tangible machine accessible storage medium comprising instructions that, when executed, cause a machine to at least obtain electroencephalographic (EEG) data from a headset, the headset comprising one or more independently adjustable bands to be disposed on a head of a user, each band having a plurality of electrodes to receive electrical signals from a brain of the user. The instructions also cause the machine to adjust a location of the electrodes on the user's head, condition the electroencephalo-

graphic data and analyze the electroencephalographic data to determine a mental state of the user.

[0157] Some example systems disclosed herein include a headset to obtain electroencephalographic (EEG) data from a user, the headset comprising one or more independently adjustable bands to be disposed on a head of a user, each band having a plurality of electrodes to receive electrical signals from a brain of the user, each band selectively rotatable relative to respective adjacent bands to adjust a location of the electrodes, and each band comprising a respective elastic strap to be effectively lengthened or shortened to adjust a compression of the electrodes on the user's head. The example system also includes a processor to receive the EEG data from the electrodes, condition the EEG data and analyze the electroencephalographic data to determine a mental state of the user.

[0158] Turning now to the figures, FIGS. 1-4 show an example headset 100. The example headset may be used for instance, to gather medical information from a patient in a medical or a home environment, to control aspects of a game or other entertainment, to provide data as part of a fitness regime, to collect audience measurement data, to control remote devices and/or multiple other uses. The example headset 100 of FIG. 1 includes a plurality of independently adjustable bands, each band comprising a plurality of electrodes for receiving signals from a head of a user, subject, viewer and/or panelist. As used herein, a participant is a person who agreed to be monitored. Typically, a participant provides their demographic information (e.g., age, race, income, etc.) to a monitoring entity (e.g., The Nielsen Company) that collects and compiles data about a topic of interest (e.g., media exposure). More specifically, the headset 100 of the illustrated example includes a first band 102, a second band 104, a third band 106 and a fourth band 108. Each of the bands 102-108 includes a plurality of electrodes. In the illustrated example, the electrodes are partially ring-shaped electrodes. The ring-shaped electrodes may have, for example, a diameter of less than about 3 mm and a length less than about 3 mm. The bigger and wider the dimensions of an electrode, the more force needed to sufficiently apply the electrode to the scalp. In some examples, the electrodes have a diameter of about 1 mm to about 2 mm. However, many other types, sizes and/or shapes of electrodes may be additionally or alternatively used as discussed in further detail below. In the example of FIG. 1, the bands 102-108 are intended to extend over the head of a user from the left side of the head to the right side of the head. Each of the bands 102-108 comprises an elongated structure with a longitudinal axis. In this example, each band 102-108 takes the form of a spine-shaped structure 110, 112, 114 and 116, respectively. Each of the spines 110, 112, 114, 116 supports an elastic adjustment band or strap 118, 120, 122 and 124, respectively. Each of the bands 102-108 is rotatably and removably coupled on one side to a first housing 126 and rotatably and removably coupled on the other side to a second housing 128. For example, the bands 102-108 may include a pivot type connection and/or a snap fastener to plug the bands 102-108 into the headset. In other examples, the bands are fixedly coupled to the headset. In the example shown, the first housing 126 may be placed near the right ear of a user and the second housing 128 may be placed near the left ear of the user so that the bands 102-108 are disposed over the head of the user for reading electrical activity along the scalp. The headset 100 of the illustrated example also includes an additional support band 130, which is adjustable and may be, for

example, elastic or any other suitable material that may be used for tightening and securing the headset 100 around the back of the head of a user. In the example shown, the headset 100 includes four bands. However, in other examples, the headset 100 may include fewer or more (e.g., three or less or ten or more) adjustable bands. Each band may carry about eight to about 256 or more electrodes per band.

[0159] In the example of FIG. 1, the bands 102-108 are rotatably and removably coupled to the first and second housings 126 and 128 to allow a user to adjust the position of the bands 102-108 over the head of the user. The bands 102-108 of this example may be rotated toward theinion (the projection of the occipital bone) or the nasion (the intersection of the frontal bone and two nasal bones) of the user to position the electrodes in specific locations for measuring electrical activity. Each of the spines 110-116 of FIG. 1 is comprised of a flexible material such as, for example, plastic, rubber, polyurethane, silicone and/or any other suitable material. The flexibility of the example spines 110-116 allows the headset 100 to sit comfortably on the head of a user. Further, the elastic straps 118-124 of the illustrated example are supported by the spines 110-116 and may be pulled to tighten the spines 110-116 downward and, thus, to increase the pressure of the electrodes against the scalp of a user. In the illustrated example, the elastic straps 118-124 are flexible and elastic. In addition, the elastic straps 118-124 of FIG. 1 are slidably and translatably coupled to the spines 110-116. Further, in the example of FIG. 1 the entire headset 100 and/or the individual bands 102-108 may be cleaned in a typical washing machine for routine cleaning and/or to disinfect and sterilize the headset 100 such as, for example, between uses or between users. In some examples there are various templates of headsets for differently sized heads. People have different head sizes based on age, sex, race and/or genetics. For example, human heads may range from about 54 cm to about 65 cm in circumference. In some examples there may be two or three template headsets. For example, a first template may accommodate heads of about 56 cm in circumference, a second template for heads of about 59 cm in circumference and a third template for heads of about 62 cm in circumference. In these examples, the center band (e.g., along the midline) may be about 23 cm, about 25 cm and about 26 cm, respectively. Thus, in some examples, the templates may include bands of multiple sizes that differ in length from about 1 cm to about 2 cm between different templates. The different template sizes are used as a coarse adjustment when fitting a headset on a subject. The adjustment of the elongated bands is then used to perfect the fit as a fine adjustment, which is detailed more below.

[0160] In the example shown, the first housing 126 includes an example adjustment mechanism 132 (shown in FIG. 10) to adjust the length of the elastic straps 118-124. The elastic straps 118-124 of the illustrated example may be pulled tight via the adjustment mechanism 132 to position the respective bands 102-108 and tighten the spines 110-116 downward toward the scalp. An example adjustment approach is disclosed in greater detail below in connection with FIG. 10.

[0161] In the example shown, the second housing 128 supports electrical components 134 such as, for example, a processor for processing the signals from the electrodes, disclosed in further detail below. In some examples, the processing occurs at the headset as an all-in-one or self-contained system. In other examples, some of the processing occurs at the headset and some processing occurs remotely after the headset transmits data or semi-processed results to a

remote site such as, for example, via a wireless connection. In still other examples, all data is streamed to a remote analyzer for processing. The electrical components **134** of the illustrated example are used to, for example, convert the electroencephalographic data from analog data to digital data, amplify the electroencephalographic data, remove noise from the data, analyze the data, and transmit the data to a computer or other network. The second housing **128** of the illustrated example includes hardware and software such as, for example, an amplifier, a signal conditioner, a data processor and/or a transmitter for transmitting signals to a data center or a computer. Each of the spines **110-116** of the illustrated example are communicatively coupled to the electrical components including the example processor via a wired connection and/or wirelessly. In other examples the electrical components **134** are supported in the first housing **126** and the adjustment mechanism **132** is supported on or in the second housing **128**.

[0162] FIG. 4A illustrates a perspective view of the headset **100** worn on the head of a user. As shown, the bands **102-108** traverse over the head from a left side to a right side. The location of the bands **102-108** may be adjusted and the elastic straps **118-124** may be tightened to tighten the bands **102-108** downward on the user's head. In the example shown, the additional support band **130** is stretched around the back of the head and may be pulled tight or adjusted to secure the headset **100** to the head of the user.

[0163] As shown in FIG. 4B, in addition to being worn in the side-to-side orientation explained above, the headset **100** of the illustrated example may be worn in a front to back orientation, wherein the first housing **126** or the second housing **128** is placed over the forehead of a user and the bands **102-108** traverse to the other of the second housing **128** or the first housing **126**, which is disposed on the back of the user's head. The bands **102-108** may be laterally adjusted and/or tightened individually for optimum reading. The orientation of FIG. 4 facilitates a midline reading of by the headset **100**.

[0164] FIG. 5 illustrates the example band **102** that may be used with the headset **100**. As seen, the first band **102** is comprised of the first spine **110** and the first elastic strap **118**. The first spine **110** is designed in a spine-like structure having a plurality of opposed extensions, **136a-136t**, similar to that of a spine and vertebrae arrangement. Each of the extensions **136a-136t** is coupled to a partially ring-shaped electrode **138a-138t**, respectively. The extensions **136a-136t** are flexible to retract and bend as the first band **102** is tightened down over the head of a user. In the example shown in FIG. 5, the electrodes **138a-138t** are molded within the extensions **136a-136t** of the first spine **110**. However, in other examples, the electrodes **138a-138t** may be removably coupled (e.g., snapped on) to the extensions **136a-136t**. Each of the electrodes **138a-138t** has its own channel running through the spine **110**. Also, in some examples, the readings from multiple electrodes may be averaged together to increase the effective surface area between the electrodes and the scalp and decrease impedance, as disclosed in more detail below. The first spine **110** further includes a housing **140** that may contain individual amplifiers and analog-to-digital converters for each of the electrode channels. The spine **110** also includes a wire **142** to communicatively couple the electrodes **138a-138t** to the processor **134** and/or to the other electrical components of the second housing **128** for processing. In other examples the spine **110** includes a wireless transmitter and power supply, for example in the housing **140**, for wire-

lessly transmitting data to the processor **134** in the second housing **128** or to another processor outside of the headset **100**.

[0165] The topside of the first spine **110** includes a plurality of runners **144a-144j**, which are extensions or protrusions for guiding and securing the first elastic strap **118** along the topside of the first spine **110**. In the illustrated example, the runners **144a-144j** are formed in pairs of two elongated runners extending along opposite sides of the elastic strap **118**. In other examples, the runners **144a-144j** are implemented by one or more elongated circular tubes running over the elastic strap **118**. The first spine **110** further includes a first eye **146** and a second eye **148**. In the example shown the second eye **148** is coupled to the housing **140**. The first elastic strap **118** is disposed between the runners **144a-144j** along the longitudinal axis on top side of the first spine **110** and also through the first and second eyes **146, 148**. The first and second eyes **146, 148** assist in maintaining the position of the elastic strap **118** on the spine **110**. The first elastic strap **118** is slidably engaged along the top side of the first spine **110** to slide as the first elastic strap **118** is stretched and pulled tight or released. In the example shown in FIG. 5, the first elastic strap **118** has a circular cross-section. However, in other examples, the first elastic strap **118** has a rectangular, elliptical, or any other cross-section shape. In some examples, the elastic strap **118** is shaped to enhance shielding of the electronic signals propagating through the spine **110**.

[0166] In the example shown in FIG. 5, the first band **102** includes 20 electrodes on the first spine **110**. However, in other examples, the first spine **110** may carry other numbers of electrodes (e.g., 256 or more individual electrodes).

[0167] FIG. 6 is an enlarged view of a portion of the first band **102**. As seen in FIG. 6, the extensions **136a-136c** and **136k-136m** are curved slightly downward, which positions the electrodes **138a-138c** and **138k-138m** downward toward the scalp. As shown in FIG. 6, the first elastic strap **118** is disposed along the top of the first spine **110** and held in place by the runners **144a-144c** and the first eye **146**. Each of the extensions **136a-136c** and **136k-136m** is coupled to a respective one of the electrodes **138a-138c** and **138k-138m**. As the first elastic strap **118** is pulled tighter, the elastic strap **118** is effectively shortened, thereby creating a downward force on the extensions **136a-136c** and **136k-136m**, which flex upward or bow outward to force the electrodes against the scalp of a user. The example bands **102-108** are designed to create a force of about 1 N/mm² to about 2 N/mm² on the scalp of a user. In some examples, the applied force is the same for each electrode.

[0168] FIG. 7 is a cross-sectional view of the first band **102** having the first spine **110** and the first elastic band **118**. The extensions **136a** and **136k** are curved downward. The electrodes **138a** and **138k** are partially ring-shaped electrodes coupled to the underside of the extensions **136a** and **136k**, respectively. The ends of the electrodes **138a** and **138k** are molded within the first spine body **110** and operatively coupled to a printed circuit board (PCB) **150**, which runs through the first spine **110**. Each of the electrodes **138a-138t** (shown in FIG. 5) is communicatively coupled to the PCB **150**. The PCB **150** of the illustrated example includes three electronics layers (e.g., layers including at least one electrical component or circuit line) and one shielding layer.

[0169] Several example methods of shielding are disclosed herein to reduce or eliminate electromagnetic interference with EEG readings including, for example, the reduction of

impedance to reduce and/or eliminate the need for external shielding in some instances. The examples disclosed herein enable high-resolution EEG measurement with high impedance skin-electrode interfaces and inter-electrode high impedance mismatches. In some examples, the high-resolution measurement is achieved by battery powered EEG measurement devices such as, for example, the headsets disclosed herein, that may include floating driven low-impedance ground, wireless communication and the example disclosed shielding techniques. FIGS. 8A, 8B and 8C illustrate the effect of impedance through example electrical circuit representations of an EEG system without external noise sources (FIG. 8A), a wet electrode EEG system with external noise sources (FIG. 8B), and a dry electrode EEG system with external noise sources (FIG. 8C), which represents the example systems disclosed herein.

[0170] FIG. 8A illustrates an example EEG system 800 in which a subject 802 is coupled to an EEG measurement device 804 such as, for example, the headsets disclosed herein. In this example, the headset 804 is a wireless EEG measurement device. The potential between a driven ground electrode 806 and a data electrode 808 is measured by applying bio-potential electrodes on the head of the subject 802. FIG. 8A represents an ideal or theoretical situation in which there is no external noise such as, for example, a completely shielded room in which the subject never moves. In such a system, measurements between the data electrode 808 and the ground electrode 806 are indicative of the signal of from the EEG source (e.g., the subject's brain) without noise artifacts.

[0171] In a real world environment (FIGS. 8B and 8C), there are external noises from electromagnetic (e.g., power lines) or electrostatic (e.g., walking) sources. Because of the low signal amplitudes of EEG data (for example, about 1 μV to about 100 μV) and high electrode-skin impedances (for example, greater than about 100 k Ω), external noise sources play a significant role in the quality of the EEG data. Electromagnetic induced noise can penetrate the EEG signal over several pathways. For example, an electric field can induce displacement current 820 (I_{EM2H} , electromagnetic source to headset) that flows through the associated capacitance 822 (C_{EM2H} , electromagnetic source to headset), into the electrode leads of the headset 804, the electrode-skin interface or individual components of the EEG device (e.g. amplifier, power supplies, etc.). Another source of electromagnetic noise is the common mode voltage on the subject's body. A displacement current 824 (I_{EM2S} , electromagnetic source to subject), flows through stray capacitance 826 (C_{EM2S} , electromagnetic source to subject). Stray capacitance is the capacitance between any two adjacent conductors. The size of this capacitance is determined by how close the subject is to power sources. The noise attributable to the stray capacitance can be as large as, for example if the subject grasps an insulated power cord, 20V.

[0172] Another source of noise is electrostatic. Friction creates charge that is stored in the capacitance 828 (C_{ES2S} , electrostatic source to subject) between the body and ground. For example, a third person who is electrostatically charged can induce a static voltage and associated current 830 (I_{ES2S} , electrostatic source to subject), into the subject if he/she moves close to the subject. Displacement current 832 (I_{ES2H} , electrostatic source to headset), is also injected and capacitance 834 (C_{ES2H} , electrostatic source to headset), is also induced from the external electrostatic noise to the headset 804.

[0173] The external noise capacitively injects displacement current 820 (I_{EM2H}), 832 (I_{ES2H}) in the subject 802 or the headset 804, which will be converted by the impedances of the data electrodes (Z_E) and ground electrode (Z_G) into additional noise that can be magnitudes higher than the signal of interest. If there are equal impedances, the noises will cancel out. In a low impedance wet system (FIG. 8B), the conversion of displacement current into additional noise is minimized such that noise can be kept under acceptable values. Typically, however, it is not achievable for the impedances of the data electrodes (Z_E) and ground electrode (Z_G) to be equal.

[0174] In a system including dry electrodes with high impedance electrode-skin interfaces (e.g., greater than about 100 k Ω) (FIG. 8C), the impedance from the data electrode (Z_E) is much greater than the impedance from the ground electrode (Z_G). In this configuration, the displacement currents 820 (I_{EM2H}), 832 (I_{ES2H}) would typically flood the system with noise. However, the examples disclosed herein couple a conductive material that has an electrode-skin impedance of less than about 100 k Ω to the body of the subject 802. Example conductive materials include an aluminum sheet and/or a silver coated nylon. The conductive material and the subject 802 form a shield 840 such that the EEG device (e.g., headset 804) is capacitively decoupled from the environment. The shield 840 is coupled to the subject via a shield electrode 842 that has a low impedance (Z_S). The shield 840 and shield electrode 848 effectively encapsulate the headset 804. The displacement currents 820 (I_{EM2H}), 832 (I_{ES2H}) that result from external noise sources such as electromagnetic sources (e.g., power lines) or electrostatic noise sources (e.g., such as walking of the subject or near other people) flows through the path of least resistance (e.g., through the shield electrode with low impedance Z_S) and, thus, these displacement currents 820 (I_{EM2H}), 832 (I_{ES2H}) are not visible at the input of the EEG measurement devices (e.g., headset 804).

[0175] In some examples disclosed herein, a low-impedance electrode-skin interface for ground and shield electrodes is realized by introducing an unconventional location for the ground electrode. For example, FIG. 9 is a schematic view of a top of head showing example electrode and ground placement using the example headset of FIG. 1 or other example headsets disclosed herein. There are several abbreviations in the diagram including "N" for nasion, "F" for frontal (e.g., in relation to the frontal lobe of a brain, which is the area located at the front of each cerebral hemisphere), "A" for ear lobe, "C" for center (e.g., in relation to a center area of the brain), "T" for temporal (e.g., in relation to the temporal lobe of the brain, which is located inferior and posterior to the frontal lobe at each cerebral hemisphere), "P" for parietal (e.g., in relation to the parietal lobe of the brain, which is located posterior to the frontal lobe), "O" for occipital (e.g., in relation to the occipital lobe of the brain, which is located at the back of the head), "I" for inion, and the subscript "z" for readings taken along the midline of the brain.

[0176] As shown in FIG. 9, a driven ground electrode 151, which in this example is a low impedance dry electrode, and an electrode for the shield are placed at the forehead. A second data electrode 153 is placed at a typical ground location such as, for example, an earlobe or a mastoid. The forehead is an unconventional location for the ground electrode 151 because of the underlying muscle movement. Ear lobes and mastoids are relatively quiet areas (e.g., relatively free from of electrode activity) of the scalp that are free of hair, which lowers

the impedance at these positions, have low brainwave activity and are less susceptible to artifacts from muscle movement such as, for example, movement of the jaw muscles. Subtracting this additional added data channel **153** from every other data channel (in either the digital domain or the analog domain) will cancel the unwanted effect of the ground electrode at the forehead. This is referred to as referencing, where the "0" potential of the system has to be shifted (or referenced). The equation in FIG. 9 shows that the effect of the ground electrode **151** at the forehead drops out when the data electrode **153** is subtracted from a data channel (e.g., data channel FC5). Thus, a low impedance electrode-skin connection (e.g., less than about 100 k Ω) is achieved without the use of gel at the forehead of a subject.

[0177] In addition to enabling the system to have a dry low-impedance interface, these examples also enhance the common mode rejection ratio (CMRR) because common signals (noise) will be attenuated by the subtraction. CMRR is where devices tend to reject input signals common to two input leads. A high CMRR is desired in applications where the signal of interest is a small voltage superimposed on potentially large voltage offset.

[0178] Examples disclosed herein obtain EEG readings of high quality with low noise for several reasons. Some such examples are self-contained units and, therefore, the EEG platform of these examples is electrically disconnected or decoupled from external electric sources. Additionally or alternatively, examples disclosed herein include a conductive layer that is coupled to the human body (e.g., the shield of FIG. 8C) and encases the EEG platform (e.g., the headset **804** of FIG. 8C). Having a low impedance coupling between the conductive layer and the human body and a high impedance to the EEG platform also capacitively disconnects the EEG platform from the environment such that external sources cannot penetrate the EEG platform and capacitive coupled displacement currents are not detectable or visible at the input of the EEG platform, as disclosed above. Thus, the EEG platform is electrically isolated from external noise sources. Examples disclosed herein provide low electrode-skin impedance such as, for example, as low as about 100 k Ω .

[0179] In other examples, additional shielding is provided. In some such examples, each electrode includes an individual shield, the cables are shielded, and/or all electronics include further shields. In some examples, the headset includes a conductive paint to enhance shielding. Also, in some examples, the headset includes a cover such as, for example, a silver-coated nylon, which also enhanced shielding.

[0180] Furthermore, as disclosed herein, some example systems utilize reduced shielding or no shielding because the electrodes gather data with such low impedance that the signal-to-noise ratio is high enough to enable the data to be processed without additional shielding. Also with such low impedance, noise sources become less relevant. The low capacitance of the components in some example systems reduces the need for additional shielding and, thereby reduces the complexity of the system. Low impedance and low capacitance may be achieved, for example, with miniature signal lines in the flexible circuit board **150** and via the use of small profile electrodes that are kept close to the head as disclosed herein.

[0181] FIG. 10 is an enlarged view of the example adjustment mechanism **132**, which can be incorporated into the first or second housing **126**, **128**. The adjustment mechanism **132** of the illustrated example comprises a magnetic block or lock

152. Each of the elastic straps **118-124** is coupled to an attachment strip **154-160**, respectively. Each of the attachment strips **154-160** comprise a plurality of vertically arranged magnetic elements, **162a-162f**, **164a-164f**, **166a-166f** and **168a-168f**, respectively. Each of the attachment strips **154-160** is magnetically releasable and lockable with the magnetic lock **152** at a plurality of positions. In the illustrated example, there are multiple positions for coupling each one of the attachment strips **154-160** to the magnetic lock **152**. The magnetic elements **162a-162f**, **164a-164f**, **166a-166f**, and **168a-168f** on the attachment strips **154-160** allow a user to adjust the length of the elastic straps **118-124**. For example, if a user wants to tighten the band **102** for comfort and/or signal connection, the user releases the corresponding attachment strip **154** from engagement with the magnetic lock **152**, pulls the attachment strip **154** in a downward direction to another magnetic element **162a-162f**, which pulls the elastic strap **118** and causes the spine **110** of the band **102** to move in a direction closer to the user's head causing the respective electrodes to more closely engage the user's scalp. The user then engages the magnetic strip **154** with the magnetic lock **152** to lock the band **102** in the desired position. If the user wants to loosen the band **102** for comfort, to adjust the electrode placement and/or signal connection, and/or to remove the headset **100**, the user may release the attachment strip **154** from the magnetic lock **152** and moves the attachment strip **154** in an upward direction to loosen the elastic strap **118** and to cause the spine **110** of the band **102** to move in a direction away from the user's head thereby causing the respective electrodes to more lightly engage or to disengage the user's scalp. The user then reengages the attachment strip **154** with the magnetic lock **152** to lock the band **102** in a desired position. The same process may be repeated with any other band. To fully remove a band, the corresponding magnetic strip is removed from the attachment lock **152** and not reengaged. Also, in some examples, there may be magnetic balls or endpoints to each elastic strip that engage one of a plurality of magnetic locks supported on the adjustment mechanism **132**. In such examples, the bands are adjustable into multiple positions defined by the position of the magnetic locks. In other examples, the elastic bands on the spine may be adjusted in any other fashion.

[0182] FIGS. 11A, 11B, 11C and 11D illustrate example electrodes that may be used with the bands **102-108** of the headset **100**. Sensor (electrode) geometries and materials affect the impedance characteristics of the signal connections. In some examples the electrodes are formed, for example, of silver or silver chloride, which may provide, for example about 10M Ω of impedance per square millimeter of contact surface. Other materials with other impedance per area values may additionally or alternatively be used.

[0183] The example ring-shaped electrode **138a** shown in FIG. 11A comprises a smooth curved element. In the example of FIG. 11A, the ends of the ring-shaped electrode **138a** are molded into the body of the spine **110**. However, in other examples, the electrodes are removably coupled to the body of the spine **110**. The electrode **138a** of the illustrated example may be constructed of any electrically conductive element. The electrodes in the illustrated example are less than about 3 mm in diameter and greater than about 3 mm in length. This configuration allows the electrode to penetrate the hair of a user and make contact with the scalp. The ring-shaped electrode **138a** of the illustrated example is suffi-

ciently resilient (e.g., springy) to flex and adjust when pressure is applied downward toward the head.

[0184] The example shown in FIG. 11B is a hook-shaped electrode 170. Similar to the example ring-shaped electrode 138a of FIG. 10, the example hook-shaped electrode 170 of FIG. 11B is curved, thereby allowing the electrode to penetrate the hair and lay against the scalp of a user. FIG. 11C illustrates an example ball electrode 172. The example ball electrode 172 of FIG. 11C comprises a shaft 174 and a ball 176. The ball 176 of the illustrated example can easily penetrate the hair and touch the scalp of a user. In some examples, the ball electrode has an impedance of about 1.3M Ω , the ball had a diameter of about 1.8 mm, and, when pressed into the tissue, the ball has an effective contact area of about 7.7 mm². Increasing the size of the electrodes increases the contact area and further decreases impedance. For example, if a ball electrode with four times the diameter of the example ball electrode described above is used, the contact area will be about 30 mm², and the impedance will be reduced to about 300 k Ω .

[0185] FIG. 11D is an example implementation of the first spine 110 equipped with a central array plate 178. In this example, there is one array plate 178. However, in other examples, there may be a plurality of array plates. The bottom side of the first spine 110 of the illustrated example includes the central array plate 178 to increase the amount of electrodes touching the scalp. The central array plate 178 of the illustrated example is embossed to include a plurality of pin-like individual electrodes. As the first elastic strap 118 (shown in FIG. 1) is tightened, reflective pressure from the scalp forces the extensions 136a-136f (shown in FIG. 5) of the first spine 110 to flex outward so the bottom of the first spine 110 is moved closer to the scalp. As the bottom of the first spine 110 approaches the scalp, some or all of the individual electrodes on the central array plate 178 penetrate the hair and touch the scalp of the user. In the example shown in FIG. 11D, the central array plate contains approximately 256 individual electrodes or more. Each electrode has its own channel that is communicatively coupled to the processor via the PCB 150. With the large number of electrodes included on the example array plate 178, the number electrodes disposed at the extension on the spines, and the number of spines included in a headset 100, the example headset 100 gathers signals from a very large number of channels. If, for example, the headset 100 includes ten spines, the number of channels could easily surpass 2000 or 3000 channels. This large number advantageously provides a larger amount of data from multiple areas of the brain to create a clearer and more comprehensive picture of brain activity. This large amount of channels also provides an oversampling, which enables virtual movement of an electrode as disclosed below.

[0186] In some examples, the array plate 178 enables the headset 100 to include about twenty-four electrodes within about a 1.5 cm radius. The electrodes within the same area likely collect the same signal or substantially similar signals. In some examples, the quality of the signals collected through the electrodes can be improved by effectively increasing the surface area of the electrode contact with the scalp by combining two or more electrodes and/or by averaging two or more of the signals collected via the electrodes within the radius for use as a single value.

[0187] In some examples, individual electrodes may be coupled in a parallel connection to effectively increase the contact area of the electrodes by the number of electrodes coupled in parallel. Because of the parallel connection, if one

electrode has a high impedance or otherwise gathers a poor signal, the effect of that electrode is small on the whole parallel configuration. The coupling of electrodes reduces the impedance and the effect of thermal noise. In some examples, the electrodes are fixedly coupled in parallel. In other examples, two or more electrodes are coupled via a switching circuit, which can be selectively activated to short out one or more electrodes to effectively increase the surface area contact between the electrodes and the tissue on the scalp. By shorting out one electrode and increasing the effective surface area of a second electrode, the impedance is lowered, which also enables the second electrode to effectively read higher frequency bands.

[0188] An example switching circuit 300 is shown in FIG. 12A. The example circuit 300 includes a plurality of electrodes, Electrode A 302, Electrode B 304, Electrode C 306 and Electrode D 308. In other examples there may be other numbers of electrodes including, for example, two, five, ten, fifty, etc. These electrodes 302, 304, 306, 308 may represent a subset of the plurality of electrodes disposed within a small area such as, for example, the area defined above with about a 1.5 cm radius. In the example, each electrode 302, 304, 306, 308 is coupled to a respective analog-to-digital converter 310, 312, 314, 316. In other examples, the electrodes 302, 304, 306, 308 may be coupled to the same analog-to-digital converter or a different number of analog-to-digital converters. In addition, in some examples, the electrodes 302, 304, 306, 308 may additionally or alternatively be coupled to other signal processing components such as, for example, the components disclosed below with FIGS. 36 and 37.

[0189] In addition, as shown in FIG. 12A, multiple electrodes such as, for example, adjacent electrodes may be coupled via switches. For example, Electrode A 302 and Electrode B 304 may be selectively electrically coupled via a first switch 318. Electrode B 304 and Electrode C 306 may be selectively electrically coupled via a second switch 320. Also, Electrode C 306 and Electrode D 304 may be selectively electrically coupled via a third switch 322. In other examples, additional and/or alternative electrode(s) may be coupled via the switches 318, 320, 322 and/or additional switch(es). In some examples, one or more of the switches includes a transistor. Also, in some examples, a controller controls each switch (e.g., controller 2 324 controls switch 322). In some examples, a single controller controls multiple switches (e.g., controller 1 326 controls switches 318, 320). The switches 318, 320, 322 can be opened to electrically decouple the associated electrodes, or the switches 318, 320, 322 can be closed to electrically couple associated electrodes. Electrically coupling two electrodes is a shorting out that increases the contact area of the shorted out electrode, which as noted above, decreases impedance and increases signal quality.

[0190] As noted above, another method to increase signal quality includes averaging signals from two or more channels (e.g., electrodes). The averaging will increase the signal-to-noise ratio by reducing both thermal noise and amplifier noise. An example graphical representation of signal averaging is shown in FIG. 12B. As shown, there are four channels (C1, C2, C3, C4) of signals represented on the logarithmic scale. The signal from each channel includes the EEG signal plus the background noise. The first peak, at 10 Hz, shows the subject closing his eyes. Thus, electrostatic noise from the contractions of the subject's muscles is increased. Another increase in background noise is the second peak, at 50 Hz, which is electromagnetic noise due to power lines (e.g.,

power line frequency in Europe). As shown in FIG. 12B, the average of the four channels, which is shown as the darkest line has the lowest values on the y-axis and, thus, carries the lowest amount of noise. As the frequency level increases, the noise reduction in the averaged signal increases such that the average is more purified from noise than any of the individual component signals. This disparity grows as frequency increases. Thus, averaging signals enables higher frequencies to be read including, for example frequencies as high as about 100 Hz or even about 120 Hz, with less noise interference.

[0191] A combination or hybrid system may also be used that combines the coupled electrodes and the averaged signals. For example, a set of electrodes within a specific area may include subsets of electrodes that are electrically coupled via fixed parallel couplings or via selective switching. Each subset may provide a high quality signal. Signals from two or more subsets may be averaged to further increase signal quality.

[0192] Furthermore, due to a large number of electrodes, a user or an automated analyzer could determine which electrodes are most optimally in contact with the scalp and gathering the clearest signal by comparing the signal quality from the electrodes. Electrodes in the vicinity with lower signal quality may then be ignored. In addition, if an electrode has a relatively weak signal and an adjacent electrode has a stronger signal, the user or automated analyzer can utilize the stronger signal and ignore the weaker signal. This enables the user or machine (e.g., the analyzer) to virtually move the electrode to the stronger signal gathering position without having to physically adjust any mechanical components (i.e., without physically adjusting the location and orientation of the bands).

[0193] FIGS. 13A and 13B are cross-sectional views of example electrodes in contact with the scalp of a user. FIG. 13A shows a traditional electrode 180 that is unable to penetrate a user's hair. Thus, the traditional electrode 180 does not make sufficient physical contact with the user's scalp, which increases the impedance and reduces signal quality. In the example of FIG. 13B, an electrode 182 is smaller and thinner than the traditional electrode 180 and is dimensioned to penetrate the hair to contact the scalp of a user directly without any hair strands and/or hair follicles underlying the electrode 182. The example electrode 182 also includes a cover 184 (e.g., a shield) for shielding the electrode from electromagnetic interference (e.g., electromagnetic waves and noise) from the environment. The example cover 184 of FIG. 13B is sufficiently wide such that it cannot penetrate all the hair on a user's head and, thus, enhances a user's comfort. However, in the illustrated example, the electrode 182 is smaller and thinner than the cover 184 so that the electrode 182 does penetrate the hair to contact the user's scalp. Thus, the electrode 180 can compress at least a portion of the stratum corneum. If the electrode is too thick, it will not be able to penetrate the hair of a user (as shown in the traditional electrode 180 of FIG. 13A). If the electrode is too thin, and sticks out too far, the electrode will create a sharp pain on the user's head. In the example shown in FIG. 13B, the electrode 182 has a diameter d_2 of about 0.5 mm and the cover 184 has an outside diameter d_1 of about 1 mm. In the example of FIG. 13B the electrode 182 has length l_1 that extends about 0.2 mm from the cover 184 to contact the scalp of a user. Because the electrode 182 is able to make direct contact with the scalp without the interference of hair, there is less impedance and less noise in a signal gathered from the electrode 182 than

from the electrode 180 shown in FIG. 13A. Therefore, less shielding is needed. In general, the smaller the diameter of the electrode in contact with the scalp, the more discomfort a user may experience. However, if the distance between adjacent electrodes is decreased and/or the number of electrodes in a specific area is increased, the force or tension applied to the headset and, thus to the electrodes, is split amongst the electrodes, which increases comfort for the user and, thus may offset the effect of the small electrode points.

[0194] FIG. 14 is a circuit diagram 1400 of an example electrode to skin contact, which may represent, for example, Z_E of FIGS. 8A-C. The coupling between the skin and the electrode is a layered conductive and capacitive structure represented by combinations of parallel resistor and capacitor (RC) elements connected in series. The parallel capacitor C_d 1402 and resistor R_d 1404 represent the coupling impedance of the double layer at the skin-electrode interface, and the parallel capacitor C_i 1406 and resistor R_i 1408 represent the input impedance of the amplifier 1410. The resistor R_s 1412 represents the minimum series contact resistance and the voltage V_{pol} 1414 represents the DC polarization potential of the body.

[0195] FIGS. 15 and 16 illustrate an alternative spine and electrode constructed in accordance with the teachings of this disclosure. An example band 1500 has a spine body 1502 and an elastic strap 1504 to tighten the spine body 1502 against the head of a user. The spine body 1502 includes a plurality of individual electrode units 1506, each having a pair of leg-shaped electrodes 1508 and 1510 pivotably coupled to the unit 1506 and projecting downwards to aim the electrodes 1508 and 1510 at the scalp of a user.

[0196] An exploded view of an example electrode unit 1506 is shown in FIG. 16. The electrode unit 1506 of the illustrated example includes the electrodes 1508 and 1510, each of which includes a shaft 1512, 1514 and a contact ball 1516, 1518, respectively. Each of the electrodes 1508, 1510 further comprises a mounting ring 1520, 1522, respectively. The mounting rings 1520, 1522 are disposed within an opening 1524 within a housing 1526. The housing 1526 comprises a plate 1528 and sleeves 1530, 1532. The mounting rings 1520, 1522 of the electrodes 1508, 1510 fit between the sleeves 1530, 1532. In the illustrated example, the shafts 1512, 1514 protrude below the plate 1528 and are angled outward from each other to contact the scalp of a user. The electrodes 1508, 1510 are pivotably coupled the housing 1526 via respective pins 1534, 1536, which are disposed through the sleeves 1530, 1532 and through the respective holes in the mounting rings 1520, 1522. In the example of FIG. 16, a spring 1538 is disposed between the mounting rings 1520, 1522 and the sleeves 1530, 1532. The spring 1538 includes tabs 1540, 1542. As the electrode unit 1506 is tightened down toward the head, the electrodes 1508, 1510 rotate and flex upward. The ends of the shafts 1512, 1514 adjacent the mounting rings 1520, 1522 are pressed against the respective tabs 1540, 1542 of the spring 1538, which biases the electrodes 1508, 1510 back down toward the head. The electrodes 1508, 1510 flex and maintain a consistent pressure downward on the scalp of a user when force is applied to the electrode unit 1506. In the illustrated example, the spring 1538 comprises a nonconductive material to keep the signals gathered from the first electrode 1508 separate from the signals gathered from the second electrode 1510.

[0197] The electrode unit 1506 of the illustrated example allows a user to easily remove and replace individual elec-

trodes. The top of the plate **1528** includes a flexible PCB **1544**, which communicatively couples the electrodes **1508**, **1510** to a processor for data processing. The PCB and the electrodes **1508**, **1510** may be coupled to the processor and/or any other analysis unit via a wired or wireless connection. As shown in FIG. 15, the band **1500** of the illustrated example includes multiple individual electrode units **1506**. Each electrode unit is hinged to the adjacent electrode unit, such that the entire band **1500** may curve around and lay against the head of a user.

[0198] FIG. 17 is an exploded view of another example electrode unit **1700** constructed in accordance with the teachings of this disclosure. In this example, the electrodes **1702**, **1704** are snap electrodes. Each of the electrodes **1702**, **1704** has a shaft **1706**, **1708** and a contact ball **1710**, **1712**, respectively. The first electrode **1702** has a top hook member **1714** and a bottom hook member **1716**. Likewise, the second electrode **1704** has a top hook member **1718** and a bottom hook member **1720**. The example snap electrode unit **1700** of the illustrated example further includes a first connector **1722**, a second connector **1724**, a flex board **1726**, a back plate **1728** and a front plate **1730**. The first and second connectors **1722**, **1724** each include a vertical portion **1732**, **1734**, respectively, and a horizontal portion **1736**, **1738**, respectively. Each of the first and second connectors **1722**, **1724** further include two apertures **1740**, **1742**, **1744**, **1746**, respectively. The vertical portions **1732**, **1734** are sized to fit within respective ones of the top and bottom hook member, **1714**, **1716**, **1718**, **1720**. The back plate **1728** includes a channel **1748** configured to receive the flex board **1726**. The front plate **1730** likewise has a channel **1750** to receive the flex board **1726**. The back plate also includes four pegs, **1752**-**1758**. Two of the pegs **1752**, **1754** are dimensioned to engage the apertures **1740**, **1742** on the first connector **1722**. The other two pegs **1756**, **1758** are dimensioned to engage the apertures **1744**, **1746** on the second connector **1724**. The front plate **1730** of the illustrated example is operatively coupled to the opposite side of the back plate **1728**.

[0199] In operation, the snap electrode unit **1700** is pressed downward against a user's head. The downward force causes the shafts **1706**, **1708** to pivot upwards. The top hook members **1714**, **1718** rotate inward onto the horizontal portions **1736**, **1738**, respectively, and, thus, against the flex board **1726**. The flex board **1726** provides a reflective force so the electrodes **1702**, **1704** keep a consistent force against the scalp of a user. The flex board **1726** also serves as the PCB to propagate any signals gathered from the electrodes **1702**, **1704** to a processor and/or other analysis unit as disclosed herein.

[0200] FIG. 18 illustrates another example electrode **1800** constructed in accordance with the teachings of this disclosure. In the illustrated example, the electrode **1800** includes a wire band **1802** and a coil electrode **1804**. In the example of FIG. 18, the coil electrode **1804** is a coil of wire wrapped around the wire band **1802** and is positioned to lie against the scalp of a user. The individual coils of the coil electrode **1804** will penetrate the hair of a user to make contact with the scalp. If the electrode **1804** rotates, the electrode **1804** will continually maintain contact with the scalp, and any signal being gathered will not be lost.

[0201] FIGS. 19A and 19B illustrate another example electrode **1900** constructed in accordance with the teachings of this disclosure. In the illustrated example, the electrode **1900** includes a wire band **1902** and a single curve electrode **1904**.

FIG. 19B is a cross-sectional view of the electrode **1900** of FIG. 19A. The single curve electrode **1904** of the illustrated example has two ball tips **1906**, **1908** at the ends of the electrode **1904**. The single curve electrode **1904** curves over the wire band **1902** so that both ends are pointed downward and both the ball tips **1906**, **1908** may contact the scalp of a user. As the wire band **1902** is stretched or tightened, the electrode coupled thereto is also stretched, and the center portion of the electrode **1904** moves closer to the scalp to provide additional pressure to the ball tips **1906**, **1908** against the scalp.

[0202] FIG. 20 shows a mold **2000** that may be used for manufacturing a spine as shown and described in FIGS. 1-7. In the illustrated example, the mold **2000** comprises a mold body **2002** and a mold cavity **2004**. The mold cavity **2004** defines the shape of a flat spine. In an example manufacturing procedure, the PCB and electrodes are placed within the mold first, and then liquid plastic or resin is injected into the cavity **2004** to form the spine body. After the molding processing the spine is remove and formed to curve the individual extensions downward.

[0203] FIG. 21 shows multiple spines **2100**, **2102**, **2104** directly after molding in the process described in connection with FIG. 20 and before the spines are shaped. In the example of FIG. 21, the spines **2100**, **2102**, **2104** comprise a plurality of electrodes **2106**, **2108**, **2110** protruding from the spines **2100**, **2102**, **2104**. The ball electrodes **2106**, **2108**, **2110** may be curved downward. In this example, the ends of each spine **2100**, **2102**, **2104** include a pin port **2112**, **2114**, **2116** for coupling the spine **2100**, **2102**, **2104** to a processing unit to a headset.

[0204] FIGS. 22A-22J are perspective views of a user's head identifying optimum areas for electrode contact. As shown in these figures, there are multiple electrode sites including, for example, twenty sites related to the International 10-20 system. These sites provide coverage of all the lobes of the brain including frontal, parietal, occipital and temporal. These sites are the accepted EEG electrode sites for a clinically valid EEG. The sites shown in FIGS. 22A-22J are selected to give broad coverage and avoid sites with excessive muscle activity. In an example headset with eighty channels, the twenty sites of the International 10-20 system are covered as are additional sites over muscle. For example the eighty channel system provides predominant coverage to non-muscle contaminated sites as well as covering muscle sites included in the standard clinical EEG system.

[0205] FIG. 22J illustrates an example headset with five bands **2202**-**2210** positioned on the head of a user for reading. The individual bands **2202**-**2210** are adjustable and may be placed along specific paths to optimize electrode placement. The example scheme of FIG. 22J bisects the head into a left section and a right section by forming a line between the nasion (between the eyes) to the inion (back of the head). A second line bisects the head along a line from the left ear canal to the right ear canal. Each of these lines is further partitioned at intervals of 10% and 20% of its distance. In the illustrated example, a first elongated band **2202** is located above a nasion of the subject at about ten percent of a distance between the nasion and an inion of the subject measured over a center of a head of the subject. A second elongated band **2204** is located above the nasion at about thirty percent of the distance to the inion. A third elongated band **2206** is located at about halfway between the nasion and the inion. A fourth elongated band **2208** is located past the halfway point, e.g., closer to the inion

than the nasion but more than thirty percent of the distance away from theinion. A fifth elongated band **2210** is located above theinion at about thirty percent of the distance. This arrangement may optimize coverage of the entire head. In other examples, additional bands are included in positions between the five illustrated bands. Still further, in other examples, the bands **2202-2210** are positioned at any other desired degree of rotation depending on the desired readings and/or the quality of electrical contact between the electrodes and the scalp.

[0206] FIG. 23 illustrates an alternative example headset **2300** constructed in accordance with the teachings of this disclosure for measuring electrical activity at the scalp. The headset **2300** of this example comprises a main headband **2302**, which curves over the top of the head of a user. Multiple support bands having individual electrodes extend from the headband **2302** in multiple directions for positioning electrodes over multiple locations on a user's head. The headset **2300** includes a left hub **2304** and a right hub **2306**, both of which are rotatably and removably coupled to the ends of the headband **2302**. In the illustrated example, the left hub **2304** includes seven support bands **2308-2320**. The right hub **2306** of the illustrated example also includes seven support bands **2322-2334**. However, in other examples, different number(s) of support bands are used to increase, decrease and/or otherwise adjust the number and/or location of electrode placement. In this example, each of the support bands **2308-2334** has a set length and two ends which are fixedly and flexibly coupled to the left and right hubs **2304**, **2306**, respectively. In some examples, one or more of the lengths of the support bands **2308-2334** are adjustable. The headband **2302** further includes front support bands **2336-2344** and rear bands **2346-2348**. In this example, each of the supports bands **2336-2348** has a set length and is fixedly and flexibly attached on one end to the headband **2302**. Also, in some examples, one or more of the lengths of the support bands **2336-2344** are adjustable. The distal ends of all the support bands **2308-2348** are operatively coupled to a respective electrode housing **2250a-2250u**. Each housing **2250a-2250u** houses an individual electrode **2352a-2352u**, respectively. In some examples, one or more of the electrode housings **2250a-2250u** support a plurality of electrodes. In the illustrated example, different ones of the support bands **2308-2348** have different lengths to position the respective electrodes **2352a-2352u** over different locations on the scalp. The locations may be selected to optimize detection of electrical activity in the brain. The support bands **2308-2348** are curved slightly inward to apply sufficient force on the head of a user to cause the respective electrode to press slightly onto the scalp to reduce noise and increase the signal-to-noise ratio to enhance signal quality. Further, the support bands **2308-2348** in the illustrated example include a flexible plastic to enable each support band **2308-2348** to flex when placed over the head of a user and accordingly adjusts to different head sizes and applies a constant and/or sufficient force to the scalp for reading the electrical signals of the brain. In the example shown in FIG. 23, the headset **2300** has twenty-one support bands and twenty-one electrodes. However, in other examples the headset includes more or fewer support bands and/or may include more than one electrode per support band.

[0207] Further, as shown in FIG. 23, the headset **2300** is coupleable to a base **2354** for storing the headset **2300** when not in use, for charging the headset **2300** and/or for data transfer as disclosed in greater detail below. The base **2354**

includes a generally vertically extending support shaft **2356** to hold the headset **2300** above a support surface such as a table, desk or shelf. The base **2354** also includes a base plate **2358** to support the base **2354** in an upright position. In some examples, the base **2354** transfers data via a wired connection to a data analyzer. In other examples, the base **2354** wirelessly transfers data.

[0208] FIG. 24 is a bottom view of the example headset **2300** of FIG. 23. The headband **2302** has a micro-USB port **2386** on the bottom for battery charging and data transfer. The headset **2300** includes a battery within the central headband **2302** and/or within a housing such as, for example, a housing located near the sides of the head (see e.g., the housings **3010**, **3012** disclosed below in connection with FIG. 30, which may be incorporated into the example headset **2300** of FIG. 23). As seen in FIG. 25, the base shaft **2356** of the base **2354** includes a male micro-USB connector **2388**, which may be inserted into micro-USB port **2386** for charging the headset **2300** and/or transferring data from a headset-based processor to a computer or a database for further processing. In other examples, any other suitable electrical and/or communication coupling may be used including, for example, other types of physical ports and/or a wireless coupling.

[0209] FIGS. 26-29 are different views of the example headset **2300**. As seen in FIGS. 26 and 27, the left and right hubs **2304**, **2306** are rotatably and pivotally coupled to the ends of the headband **2302**. The left hub **2304** has an adjustment ball **2360** that fits within a left socket **2362** on the inside of the headband **2302**. The adjustment ball **2360** and left socket **2362** (i.e., ball and socket joint) allow the hub **2304** to rotate and pivot in any desired direction to position the support bands **2308-2320** over desired locations on the left side of a user's head. The right hub **2306** also has an adjustment ball **2364** that is designed to fit within a right socket **2366** on the headband **2302**. Thus, the right hub **2306** also is coupled to the headband via a ball and socket joint to enable the hub **2304** to rotate and pivot in any desired position. FIG. 28 shows the headband **2302** slightly curved to the back such that the headset **2300** is supported at a crown of the head while the left and right hubs **2304**, **2306** are positioned near the left and right ear, respectively.

[0210] FIG. 29 is a bottom view of the headset **2300** and shows that the headset **2300** includes a pad **2368** that provides comfort to the user and also may be used to provide stability to the headset **2300** so that the headset **2300** maintains its position as the user moves his or her head. Increasing the stability of the headset **2300** also decreases any noise that may be generated by friction caused by movement of the electrodes along the scalp of the user. In addition, the pad **2368** may double as a housing that encases electrical components such as, for example, a processor, which may, for example, comprises hardware, firmware and/or software for processing the signals from the electrodes, converting the electroencephalographic data from analog data to digital data, amplifying the electroencephalographic data, removing noise from the data, analyzing the data, and/or transmitting the data to a computer or other network. The headset **2300** comprises a printable circuit board **2370** that is disposed within the headband **2302** and the support bands **2308-2344** to communicatively couple the electrodes **2352a-2352u** to the processor for processing. Also, in some examples, the housing **2368** may encase a power supply such as, for example, one or more batteries.

[0211] FIG. 30 illustrates an exploded view of example layers for an example headset 3000. Though an alternative shape is shown in FIG. 30, the layering concepts shown in FIG. 30 may be used for any suitable headset structure including, for example, the headset 100 of FIG. 1, the headset 1500 of FIG. 15, a headset created in the mold 2000 of FIG. 20, the headset 2300 of FIG. 23 and/or other suitable headset. The first layer 3002 comprises a plastic and/or metal housing layer. The first layer 3002 provides tension and shape to the headset 3000 as well as the flexibility needed to adjust the headset and apply sufficient pressure at each electrode to optimize signal gathering. The dimensions (e.g., width) of each arm in the layer is specifically designed for a particular tension (e.g., to optimize performance). The second layer 3004 is the flexible circuit board that is used to transmit data gathered at each electrode to the electronics/processor. The headset 3000 includes a third layer 3006 and fourth layer 3008 at each end. The third layer 3006 corresponds to the material of the first layer 3002 and the fourth layer 3008 corresponds to the material of the second layer 3004. The first layer 3002 and the third layer 3006 provide shielding to the signals as the signals propagate along the second layer 3004 and the fourth layer 3008. Also, the material used may be selected to enhance shielding for the flexible PCB and electromagnetic interference shielding for the example systems. Also, the PCBs of the second layer 3004 and fourth layer 3008 are flexible and thin and include thin wiring that has low impedance and low capacitance, which reduces loss during signal propagation.

[0212] The headset 3000 also includes a first housing 3010 and a second housing 3012. An example of the first and second housing is shown in greater detail in FIG. 31. Each housing includes a cover 3014 and a support ring 3016. The electronic components and processor are supported in one of more of the housings 3010, 3012. Additionally or alternatively, in some examples, an adjustment mechanism such as, for example, the adjustment mechanism of FIG. 9 is supported by one or more of the housings. Though an oval shape is shown in FIGS. 30 and 31, any suitable shape may be used for the housings.

[0213] FIGS. 32A and 32B illustrate top and bottom perspective views of an example snap electrode unit 2372. The snap electrode unit 2372 comprises back plate 2374 and an electrode layer 2376. The electrode layer 2376 may comprise a silver coated electrode or an electrode coated with or made from any suitable conductor. The back plate 2374 has a shaft 2378, which extends through the PCB 2370 and support band 2390 into the back of the electrode 2376 to couple the electrode 2376 to the PCB 2370 and the support band 2390. The electrode may be readily assembled with the back plate or disassembled from the back plate to facilitate replacement of the electrodes. FIGS. 32C and 32D illustrate a snap electrode unit 2372 with an alternative contact electrode 2380.

[0214] FIG. 33 is an enlarged view of the example electrode housing 2350 and the example electrode unit 2352 of FIG. 23. As shown in FIG. 33, the housing encloses the back plate 2374 (shown in FIGS. 32A-32D) but the shaft 2378 extends from the housing to receive the electrode. In the illustrated example, the electrode unit 2352 includes an alternative elongated electrode 2382. In other examples, the electrode has any other shape or size appropriate to contact the scalp of a user to receive electrical signals.

[0215] FIG. 34 is a perspective view of an example net array headset 3400. The net array headset 3400 includes a plurality

of elastic bands 3402a-3402m that forms a zig-zag or criss-cross pattern. An electrode 3404a-3404i is located at each intersection of the elastic bands 3402a-3402m. A plurality of the elastic bands 3402a-3402g converges in the back of the net array headset 3400 and is coupled to an adjustment knob 3406. As the adjustment knob 3406 is turned, the individual elastic bands 3402a-3402m (and others unnumbered) are pulled tight and the electrodes 3404a-3404c (and others unnumbered) are forced downward onto the scalp of a user. The adjustment knob 3406 allows the net array headset 3400 to be adjustably used on a range of differently sized heads. As shown in FIG. 35 the adjustment knob 3406 is rotatable to wind up the individual elastic bands 3402a-3402g and, thus, tighten the net array headset 3400 onto the head of a user. The net array headset 3400 enhances the fit of electrodes on differently shaped heads and produces a light and portable headset.

[0216] FIG. 36 is a block diagram of an example processing system 3600 for use with any of the headsets disclosed herein. The example system 3600 includes a plurality of electrodes 3602. The electrodes 3602 are coupled, for example, to a headset to be worn on a head of a subject. In some examples, the headset includes a plurality of elongated bands that extend between a first housing located near a first ear of a subject and a second housing located near a second ear of the subject. In some examples, one or more of the elongated bands is rotatably and/or removably coupled to each of the first and second housings such that the electrodes 3602 can be moved to different positions on the head and/or removed from the headset. The headset may include numerous channels of electrodes such that multiple (e.g., 2000 or more) electrodes are included in the example system 3600. In addition, in some examples, the pressure applied on the head by each electrode may be adjusted by adjusting an elastic band or strap associated with each of the elongated bands.

[0217] The electrodes may have any suitable shape such as, for example, at least a portion of a ring, a ball, a hook and/or an array. The electrodes 3602 may include one or more of the properties of any of the electrodes disclosed in this patent. In addition, different types of electrodes may be included in the system 3600. Also, in some examples, the electrodes 3602, and the elongated bands to which the electrodes 3602 are coupled, have a protective covering such as, for example, a nylon and/or a silver mesh. In some examples, the covering is a stretchable silver-coated nylon mesh. The covering provides additional shielding and protection. In addition, the electrodes 3602 including the covering may be machine washable.

[0218] The example electrodes 3602 may also be adjustably mechanically coupled, such as for example, via the elongated bands to a first housing where an adjustable locking mechanism is supported to releasably hold the elongated bands and, thus, the electrodes 3602 in one or multiple positions. An example locking mechanism includes the magnetic lock disclosed above.

[0219] The electrodes 3602 are also communicatively coupled to a second housing (e.g., the second housing 128 of the headset 100 shown in FIG. 1) that supports an electrical processing unit 3604 via a communication line 3606, which may be for example a wired or wireless communication link including, for example, the PCB communication channels disclosed above. The example processing unit 3604 includes

an analog-to-digital converter **3608**, a signal conditioner **3610**, a database **3612**, an analyzer **3614** and a transmitter **3616**.

[0220] The analog-to-digital converter **3608** converts the analog signals received at the electrodes **3602** to digital signals. In some examples, the analog-to-digital converter **3608** is located in the processing unit **3604** at one of the housings of the headset. In other examples, the analog-to-digital converter **3608** comprises multiple A-D converters located to service individual or sets of the electrodes to convert the signals as close to the source as possible, which may further reduce interference.

[0221] The signal conditioner **3610** of the illustrated example prepares the gathered signals so that the data is in a more usable form. For example, the signal conditioner **3610** may include an amplifier to amplify the signal to a more detectable level. In addition, the signal conditioner **3610** may include a filter to remove noise from the signal. The filter may also be used as a bandpass filter to pass one or more frequency bands and/or manipulate select bands depending on the desired processing and/or analysis. For example, in analyses to study only the alpha waves, the signal conditioner may be programmed to present only those frequencies between about 7.5 and about 13 Hz. In some examples, each of the electrodes **3602** may include a signal conditioner at or near the electrode **3602**. The example signal conditioner **3610** may include hardware and/or software to execute a signal conditioning method. In some examples, the signal conditioner includes a detrending unit to compensate for electrode polarization, in which there is slow movement of the voltage signal unrelated to brain wave activity due to polarization of the electrodes. The example processing unit **3604** also provides signal processing that may include hardware and/or software to execute Fast Fourier Transform (FFT) measurements, coherence measurements and/or custom adaptive filtering.

[0222] The analyzer **3614** is to analyze the data gathered from the electrodes **3602** and processed by the analog-to-digital converter **3608** and the signal conditioner **3610** in accordance with one or more analysis protocols depending on the desired study. For example, in accordance with some studies, the analyzer **3614** may process the data to determine one or more of a subject's mental state, physiological state, attention, resonance or memory, emotional engagement and/or other suitable characteristics of the subject.

[0223] The transmitter **3616** communicates the data at any stage of processing and/or the results of the analysis from the analyzer **3614** to an output **3618**. The output **3618** could be a handheld device, an alarm, a display screen on the headset, a remote server, a remote computer and/or any other suitable output. Data transmission may be implemented by Bluetooth transmission, wi-fi transmission, ZigBee transmission and/or proprietary encryption before transmission. In the illustrated example, the database **3612** stores all data gathered streams. The streams can be buffered for streaming or stored on-board (i.e., at the headset) for periodic or aperiodic uploads during, for example, low-activity periods.

[0224] The processing unit **3604** components **3608-3616** are communicatively coupled to other components of the example system **3600** via communication links **3620**. The communication links **3620** may be any type of wired connection (e.g., a databus, a USB connection, etc.) or a wireless communication mechanism (e.g., radio frequency, infrared, etc.) using any past, present or future communication protocol (e.g., Bluetooth, USB 2.0, USB 3.0, etc.). Also, the com-

ponents of the example system **3600** may be integrated in one device or distributed over two or more devices.

[0225] While example manner of implementing the system **3600** has been illustrated in FIG. **36**, one or more of the elements, processes and/or devices illustrated in FIG. **36** may be combined, divided, re-arranged, omitted, eliminated and/or implemented in any other way. Further, the example signal conditioner **3610**, the example A/D converter **3608**, the example database **3612**, the example transmitter **3616**, the example analyzer **3614**, the example output **3618** and/or, more generally, the example system **3600** of FIG. **36** may be implemented by hardware, software, firmware and/or any combination of hardware, software and/or firmware. Thus, for example, the example signal conditioner **3610**, the example A/D converter **3608**, the example database **3612**, the example transmitter **3616**, the example analyzer **3614**, the example output **3618** and/or, more generally, the example system **3600** of FIG. **36** could be implemented by one or more circuit(s), programmable processor(s), application specific integrated circuit(s) (ASIC(s)), programmable logic device(s) (PLD(s)) and/or field programmable logic device(s) (FPLD(s)), etc. When any of the apparatus or system claims of this patent are read to cover a purely software and/or firmware implementation, at least one of the example signal conditioner **3610**, the example A/D converter **3608** or the example database **3612** are hereby expressly defined to include hardware and/or a tangible computer readable medium such as a memory, DVD, CD, etc. storing the software and/or firmware. Further still, the example system **3600** of FIG. **36** may include one or more elements, processes and/or devices in addition to, or instead of, those illustrated in FIG. **36**, and/or may include more than one of any or all of the illustrated elements, processes and devices.

[0226] FIG. **37** illustrates another example system **3700** that may be implemented, for example, by one or more of the example headsets **100**, **2300**, **3400** shown in FIGS. **1**, **23** and **34**. The example system **3700** of FIG. **37** may be used to enhance signal strength by, for example, shorting out one or more electrodes to effectively increase a surface area of an electrode using, for example, the example circuit **300** of FIG. **12A**. Increasing surface area lowers the impedance and improves the signal-to-noise ratio of the data gathered at the electrode. In addition, the example system **3700** may be used to virtually move an electrode by selecting one or more input channels to choose more effective electrode locations occupied by electrodes obtaining high quality and less noisy signals. These electrodes may be, for example, the electrodes that have optimum or near optimum contact with the scalp. The system **3700** enables a user or an operator to discard electrodes that are inoperable, mis-operating or insufficiently coupled to the scalp and/or the remainder of the headset.

[0227] The example system **3700** of FIG. **37** includes any number of input channels (e.g., a first input channel **3702**, a second input channel **3704**, a third input channel **3706**, a fourth input channel **3708** . . . n input channels **3710**). For example, as disclosed above, one or more of the headsets disclosed herein may include 2000 or more input channels. In this example, the input channels **3702-3710** are each associated with an electrode. In other examples, one or more of the input channels **3702-3710** may be associated with other type(s) of sensor(s) such as, for example, an eye tracker, a galvanic skin response sensor, a breath rate sensor, a thermometer, a sphygmomanometer to measure blood pressure, a functional magnetic resonance imaging sensor and/or other suitable

types of sensors. Such sensor(s) may be freely added or removed. Some sensor(s) may be added to the headset itself, and other sensor(s) may be coupled to an arm, a chest or other body part and communicatively coupled to the headset.

[0228] The example system 3700 of FIG. 37 includes an analyzer 3712. In the illustrated example, the analyzer 3712 is implemented by a programmed processor. The example analyzer 1712 of FIG. 37 includes an evaluator 3714, a conditioner 3716 and a selector 3718. In some examples, one or more of the components 3714-3718 of the analyzer 3712 are incorporated into a housing such as, for example, the second housing 128 of the headset 100 shown in FIGS. 1-3. In other examples, one or more of the components 3714-3718 of the analyzer 3712 are incorporated into a handheld device, a local computer, a remote server or other suitable device. The evaluator 3714 evaluates the properties of the incoming signals, such as for example, strength, amplitude, signal-to-noise ratio, duration, stability and/or other suitable signal characteristics indicative of the integrity of the data and/or the quality of the connection between the headset and the scalp. Example methods to determine what signals are acceptable include, for example, comparing one or more aspects of a signal from a given electrode (e.g., its amplitude, frequency, etc.) to one or more of an absolute threshold, a spectral threshold, a ramp-rate threshold, a low-activity (flat) threshold and/or performing a neighborhood correlation between the signal of a given electrode and signals from one or more other electrodes near the given electrode.

[0229] The example conditioner 3716 of the illustrated example amplifies and/or filters the signal to improve signal quality. If the conditioner 3716 enhances the quality of a signal to acceptable levels such that the signal is usable, the evaluator 3714 of the illustrated example determines that the integrity of data from the associated electrode is acceptable and that the data does not need to be discarded and/or that the data from the electrode does need to be ignored or discarded.

[0230] The selector 3718 of the illustrated example selects which input channels to ignore, use, and/or merge (e.g., average) to improve (e.g., optimize) the overall input based on the determinations of the evaluator 3714. The plurality of input channels 3702-3710 are communicatively coupled to the analyzer 3712 and corresponding components 3714-3718 via communication links 3720 (e.g., any wired or wireless communication links).

[0231] In the example system 3700 shown in FIG. 37, the example evaluator 3714 determines which of the input channels 3702-3710 (e.g., electrodes) are collecting the best, most useful, and/or most accurate data. Based on this determination, the example selector 3718 identifies which electrodes/input channels are most effective (e.g. for the best EEG readings) and which electrodes/input channels should be ignored to improve the readings. Ignoring an electrode/communication may involve disabling the channel (e.g., via a switching circuit) and/or ignoring the data it collects. Disabling an electrode effectively increases the surface area contact between one or more electrodes adjacent the disabled electrode and the tissue on the scalp. Disabling one electrode/channel can be referred to as shorting out the electrode. By shorting out an input channel (e.g., effectively increasing the effective surface area of another electrode at an adjacent input channel), the overall impedance of the channels is lowered and signal quality is improved. Lower impedance and better signal-to-noise ratio enables the example system 3700 of FIG. 37 to read higher frequency bands. Selection of which

electrode(s) are candidates for shorting is based on regional coverage and data quality. For example, if there is increased noise in multiple electrodes in a small neighborhood of electrodes, some or all of such electrodes can be shorted to improve the signal to noise ratio. Furthermore, with a large number of input channels, the selector 3718 may determine which electrodes are in best contact with the scalp and gathering the clearest signal. Other electrodes in the vicinity may be ignored and/or shorted out with a switching circuit 300 (FIG. 12A), 3722 (FIG. 37). In addition, if an input channel provides a relatively weak signal and an adjacent input channel provides a stronger signal, the selector 3718 emphasizes the input channel with the stronger signal by deselecting the channel with the weaker signal. Deselecting a signal (e.g., disabling it via the switching circuit 3722) and relying on the data collected by adjacent electrodes can be thought of as moving the function of the deselected electrode to the adjacent electrode. Thus, the example system 3700 of FIG. 37 can virtually move an electrode to a stronger signal gathering position without having to physically adjust any mechanical components (i.e., without physically moving the electrode over).

[0232] While example manner of implementing the system 3700 has been illustrated in FIG. 37, one or more of the elements, processes and/or devices illustrated in FIG. 37 may be combined, divided, re-arranged, omitted, eliminated and/or implemented in any other way. Further, the example analyzer 3712, the example evaluator 3714, the example conditioner 3716, the example selector 3718, the example switching circuit and/or, more generally, the example system 3700 of FIG. 37 may be implemented by hardware, software, firmware and/or any combination of hardware, software and/or firmware. Thus, for example, the example analyzer 3712, the example evaluator 3714, the example conditioner 3716, the example selector 3718, the example switching circuit 3720 and/or, more generally, the example system 3700 of FIG. 37 could be implemented by one or more circuit(s), programmable processor(s), application specific integrated circuit(s) (ASIC(s)), programmable logic device(s) (PLD(s)) and/or field programmable logic device(s) (FPLD(s)), etc. When any of the apparatus or system claims of this patent are read to cover a purely software and/or firmware implementation, at least one of the example analyzer 3712, the example evaluator 3714, the example conditioner 3716, the example selector 3718 or the example switching circuit 3720 are hereby expressly defined to include hardware and/or a tangible computer readable medium such as a memory, DVD, CD, etc. storing the software and/or firmware. Further still, the example system 3700 of FIG. 37 may include one or more elements, processes and/or devices in addition to, or instead of, those illustrated in FIG. 37 and/or may include more than one of any or all of the illustrated elements, processes and devices.

[0233] FIG. 38 illustrates an example system 3800 that includes a headset 3812, which is representative of one or more of the example headsets and/or systems described herein, such as, for example, the headset 100 of FIG. 1, the headset 2300 of FIG. 23, the headset 3400 of FIG. 34, the system 3600 of FIG. 36, the system 3700 of FIG. 37 and/or the system 3900 of FIG. 39 (disclosed below) with additional physiological sensor(s). The example system 3800 may be used for in-home patient monitoring, treatment and/or diagnosis of medical conditions, to detect life-threatening situations, to ascertain patient compliance with a prescribed medi-

cal regime and/or other suitable applications. Currently patients need to go to the hospital for neurological monitoring. This entails increased risk of exposure to hospital pathogens (such as, e.g., acquired bacterial infections). However, in a hospital environment, there are skilled technicians to monitor the data, detect issues and alarm medical staff. Though there is no guarantee that data of interest defining neurological status will not be missed. In the home environment, the example headsets and/or systems disclosed herein automatically monitor the data, detect issues, and alarm the patient, an emergency call center, paramedics, a doctor and/or a local hospital if there are medical issues and/or emergencies. For example, a patient may have an aura (warning) of a seizure at home and not have time to get to the hospital for monitoring. A self-applied, home EEG monitoring system including the examples headsets disclosed herein enable the capture this information critical for appropriate care. In addition, the self-application systems disclosed herein enable a patient to transmit data, question(s), communication(s) and/or other information to a medical care professional when the patient feels there is something symptomatically wrong with their physiology including, for example, underperformance in the cognitive domain. Furthermore, hospitals have skilled technicians to monitor data quality and equipment function. Examples disclosed herein automatically perform those functions, thereby achieving cost savings and reducing the possibility of human error.

[0234] Also, the headsets and/or systems produce data that may be used with telecommunication and/or other information technologies to provide clinical health care from a remote location. For example, a patient may be examined and/or monitored by sending sensor data to a remote doctor or physician. In some examples, EKG data may be monitored such as, for example, 24 hour at home monitoring of cardiac arrhythmia patients. In such examples, an EKG sensor is attached to the in-home patient whereby the system is coupled to a phone line, the internet or other communication link. The EKG readings are transmitted directly to the patient's cardiologist (and/or a technician, nurse, etc.) over the communication link. The example system 3800 of FIG. 38 is usable for many type(s) of patients with many type(s) of conditions including cardiac arrhythmia, epileptic seizures, stroke, small vessel disease, dementia, memory loss, Alzheimer's, glucose monitoring, blood pressure, hypertension, cognitive decline, depression and/or other conditions. Other physiological conditions, psychiatric conditions, disease progression, disease intervention effectiveness and/or developmental disorders are also monitorable with the system, 3800 such as, for example, bipolar disorder, schizophrenia, attention deficit hyperactivity disorder (ADHD) and/or autism.

[0235] With respect to EEG data and the headsets used to gather the data, traditional systems have been uncomfortable to wear, require messy gels, are costly to manufacture and/or require extensive training to use. Example headsets 100, 2300, 3400, 3812 disclosed herein are useful (e.g., optimal) for in-home patient monitoring because such disclosed headsets 100, 2300, 3400, 3812 are comfortable to wear, easy to operate, provide effective electrode-to-tissue contact, comprise a large number of electrodes and/or are adjustable to accommodate differently sized heads. In some examples, data from the example headsets 100, 2300, 3400, 3812 is processed at the headset and transmitted to an off-site monitoring station for analysis by medical personnel (e.g., a doctor

or physician). In some examples, data storage occurs at the headset, at a remote data center or a combination thereof.

[0236] The example headsets 100, 2300, 3400, 3812 disclosed herein are combinable with additional biometric, neurological and/or physiological system(s) to monitor, examine, treat and/or diagnosis multiple medical conditions including physiological conditions and/or mental conditions. In the example system 3800, data from an EEG system 3802 is combined and aggregated with data from an EKG system 3804, a glucose monitoring system 3806, an EOG system 3808, a facial monitoring system 3809 and/or any other plug-in/play-and-play system 3810 (e.g., installable or coupleable programs and/or devices to add additional functionality), such as for example, eye-tracking sensor(s) (e.g., the eye tracking sensor 3910 of FIG. 39), galvanic skin response (GSR) signal(s), EMG signal(s), camera(s), infrared sensor (s), interaction speed detector(s), touch sensor(s) and/or any other sensor capable of outputting physiological and/or neurological data to the headset 3812 or directly to the off-site monitoring station. In addition, in some examples, the example facial monitoring system 3809 includes to have a full facial and/or hemifacial coverage camera to enable facial affect coding (FACS), which allows categorization of facial expressions. In some examples, the example facial monitoring system 3809 includes a camera coupled to a telescopic boom.

[0237] In the illustrated example, the headset 3812 includes the EEG system 3802, a local analyzer 3814 (which, for example, may be incorporated into the second housing 128 of the headset 100 of FIG. 1), an output 3816 and a manual input 3818. In the illustrated example, the sub-systems 3802-3810 are communicatively coupled the headset 3812 and, thus, the local analyzer 3814 via communication link 3820, which may include hard wire and/or wireless technology. Also, in some examples, one or more the sub-systems 3802-3810 may be incorporated into the headset itself (e.g., the EOG system 3808 and/or the facial monitoring system 3809).

[0238] Each of the signals from the different sub-systems 3802-3810 represents an input. Each input may be filtered, conditioned and/or processed to formulate an output representing one or more properties or characteristics of the patient's condition. In the illustrated example, the EKG system 3804 is coupled to a patient's chest, and the EKG data is wirelessly sent to the EEG headset 3812. The EKG data is processed by the local analyzer 3814 and sent to a remote facility 3822 for treatment, diagnosis and/or monitoring of the patient. The remote location may be, for example, a doctor's office, a hospital, a clinic, a laboratory, an archive, a research facility and/or any other diagnostic facility. The local analyzer 3814 may be communicatively coupled to the remote facility via a communication channel 3824 such as common telephone line, landline, an internet connection, radio waves, and/or any other communication technology capable of sending signals. In the example shown in FIG. 38, the local analyzer 3814 includes a clock 3826 and a database 3828. The clock 3826 of the illustrated example time stamps the data for use, for example, in monitoring the progress of a condition or a treatment and/or generating medical records. The database 3828 of the illustrated example is used for local storage.

[0239] In the example shown in FIG. 38, the local analyzer 3814 creates the output 3816. The output 3816 may be, for example, a light, a sound, a display and/or any other output that may be used, for example, to alert a patient of a need to

seek medical attention, to take a dosage of medicine, to start an activity, to stop an activity, to eat something and/or any other suitable warning and/or command. In some examples, the output **3816** is operatively coupled to an auto-delivery system for automatically delivering medicine to a patient in response to certain readings from the system **3800**. Diabetic patients, for example, often require continuous glucose and blood pressure monitoring. The example system **3800** may monitor and deliver insulin automatically to a patient based on the measured physiological characteristics. In the example shown, the output **3816** (e.g., a light, a speaker, a display, an auto-delivery system) is incorporated into the headset **3812**. In other examples, the output **3816** may be separate from the headset **3812**, and the headset may communicate with the output **3816** via the wired or wireless communication links disclosed herein.

[0240] The example system **3800** maybe be used to detect and/or treat psychiatric conditions such as, for example, depression. For example, a patient's brain waves may be monitored by headset **3812** via the EEG sub-system **3802**. If the local analyzer **3814** detects that the patient is becoming more depressed, then small doses of anti-depressants may be automatically injected and/or the output **3816** may sound an audible message or alarm that directs the patient to self-administer a dosage of medicine. Alternatively, the output signal **3816** may be communicatively coupled to a remote monitoring station such as a doctor's pager, such that when certain readings indicate that the patient has developed a dangerous condition, a doctor is paged to respond and/or an alarm is set to direct the patient to seek medical attention.

[0241] Another benefit to the at-home system **3800** is the volume and completeness of patient data due to the continual recording and measuring of patient vitals and/or other physiological and/or neurological condition(s). Commonly, people are asked what they were doing just before and after an occurrence of a medical event, such as for example, a seizure. Patients often experience difficulty tracking and/or recalling their day-to-day activities with such precision. However, with the example system **3800**, the local analyzer **3814** records the patient's statistics and/or activities. The example self-application systems disclosed herein enable the development of daily logs or flow charts of brain activity, which is usable to identify relationships among and/or trends in behavior, medication and physiological performance. Also, in some examples, the headset is provided with geographic tracking technology (e.g., GPS, etc.) to identify where a patient is located (e.g., the kitchen, a neighbor's home, the living room, etc.) at certain times. In some examples, the local analyzer **3814** prompts the patient to enter his or her daily activity periodically or as specific medical events occur such as, for example, as spikes in one or more readings occur. The example system **3800** of FIG. 38 includes the manual input **3818** to facilitate patient entry of such information. In some examples, the manual input **3818** is carried by the headset **3812**. For example, the manual input **3818** may be an interactive (e.g., touch) screen, a microphone and/or a keypad on a surface of the headset **3812**. In other examples, the manual input **3818** could be a remote device such as, for example, a handheld device, a computer, a mobile phone, a tablet and/or a television that is communicatively coupled to the system **3800**.

[0242] Thus, the examples disclosed herein enable the collection, recordation, charting and/or development of baseline activity and a comparison of patient activity to the baseline on

an on-going basis. The baseline development is patient-specific based on the volume of gathered data. Therefore, the baseline is not based on societal norms or averages, but rather, is shiftable and adaptable to the individual patient. The example systems and headsets disclosed herein also include on-board storage, processor, time tracking and spectral tracking to enable continuous charting/status evaluation for patients, medication usage and/or feedback improvement applications to increase patient compliance and/or response. In some examples, the self-application systems disclosed herein also provide prompts on/in response to potential salient events. For example, the examples disclosed herein can prompt to a patient to go see a physician if needed. In some examples, the prompts are based on changes in mental states and/or activities and/or significant deviations from the individual patient's norms such that the response or action prompt is tailored to the specific individual.

[0243] The volume and completeness of data collected by the example system **3800** enable the development of real-time reports that provide effective data in diagnosing and treating medical conditions. For example, a patient with ADHD may have a reading that indicates he/she is having increased brain activity in certain regions of the brain associated with lack of concentration. In response, the local analyzer **3814** may prompt the user via the manual input **3818** to enter what he/she was recently doing (e.g., drinking a can of cola). In another example, a depressed patient may have a reading indicating he/she is cheerful and happy. The local analyzer **3814** will prompt the patient to record what he/she was doing just prior to the reading. Such activity may be incorporated into a treatment plan to assist the patient in maintaining a desired mental state (e.g., happiness). In another example, a person with high blood pressure may be monitored. If his/her blood pressure increased, the patient may be asked what he or she ate or drank just prior the reading. Therefore, with the example system **3800**, a patient can readily input data, and the physician can interpret the data and more accurately diagnosis health conditions and/or activities that affect such conditions.

[0244] While example manners of implementing the system **3800** have been illustrated in FIG. 38, one or more of the elements, processes and/or devices illustrated in FIG. 38 may be combined, divided, re-arranged, omitted, eliminated and/or implemented in any other way. Further, the example local analyzer **3814**, the example clock **3826**, the example database **3828**, the example output **3816**, the example manual input **3818**, the example EEG sub-system **3802**, the example EKG sub-system **3804**, the example glucose monitoring sub-system **3806**, the example EOG sub-system **3808**, the example facial monitoring system **3809**, the example plug-in/plug-and-play **3810** and/or, more generally, the example system **3800** of FIG. 38 may be implemented by hardware, software, firmware and/or any combination of hardware, software and/or firmware. Thus, for example, the example local analyzer **3814**, the example clock **3826**, the example database **3828**, the example output **3816**, the example manual input **3818**, the example EEG sub-system **3802**, the example EKG sub-system **3804**, the example glucose monitoring sub-system **3806**, the example EOG sub-system **3808**, the example facial monitoring system **3809**, the example plug-in/plug-and-play **3810** and/or, more generally, the example system **3800** of FIG. 38 could be implemented by one or more circuit(s), programmable processor(s), application specific integrated circuit(s) (ASIC(s)), programmable logic device(s) (PLD(s)) and/or

field programmable logic device(s) (FPLD(s)), etc. When any of the apparatus or system claims of this patent are read to cover a purely software and/or firmware implementation, at least one of the example local analyzer **3814**, the example clock **3826**, the example database **3828**, the example output **3816**, the example manual input **3818**, the example EEG sub-system **3802**, the example EKG sub-system **3804**, the example glucose monitoring sub-system **3806**, the example EOG sub-system **3808**, the example facial monitoring system **3809** or the example plug-in/plug-and-play **3810** are hereby expressly defined to include hardware and/or a tangible computer readable medium such as a memory, DVD, CD, etc. storing the software and/or firmware. Further still, the example system **3800** of FIG. **38** may include one or more elements, processes and/or devices in addition to, or instead of, those illustrated in FIG. **38**, and/or may include more than one of any or all of the illustrated elements, processes and devices.

[0245] FIG. **39** illustrates an example attention and control system **3900** that may be used for determining, processing and/or evaluating a user's attention to media and/or to manipulate an input on an external electrical device without physical movement, (e.g., by using only the user's mind). The example system **3900** includes a headset **3902**, which may be implemented for example, with the example headsets and/or systems disclosed herein such as, for example, the headset **100** of FIG. **1**, the headset **2300** of FIG. **23**, and/or the headset **3400** of FIG. **34**. The headset **3902** processes EEG signals and/or other sensor data to develop a picture of a mental state of a user including, for example, an emotional state, a state of engagement, a state of attention and/or any other neurological state. As disclosed below, the example system **3900** of FIG. **39** may be used to determine if the user is paying attention to a media program, to determine where a user's eyes are focused, to determine that the user wants to control a remote device and effect that control (e.g., change the volume on a television), and/or for other applications. In the illustrated example system **3900**, the headset **3902** includes analyzer components including an EEG sensor **3904**, a program identifier **3906**, a remote action evaluator **3908**, an eye tracker sensor **3910**, an accelerometer **3911**, an attention evaluator **3912**, a database **3914** and a transmitter **3916**. The analyzer components **3904-3914** are communicatively coupled via a communication link **3918** such as, for example, any communication described above. The analyzer components **3904-3914** may be, for example, incorporated into or otherwise supported by the headset **3902** such as the headset **100** shown in FIG. **1**, the headset **2300** shown in FIG. **23** or the headset **3400** shown in FIG. **34**. In some examples, the analyzer components **3904-3916** are housed in a compartment on a headset, such as, for example, the second housing **128** of the headset **100** shown in FIGS. **1-3**.

[0246] As disclosed above example headsets **100**, **2300**, **3400** include a plurality of individual electrodes to detect electrical activity along the scalp of a user. This data may be used to determine attention, memory, focus and/or other neurological states. The EEG sensor **3904** of the example of FIG. **39** is implemented by the electrodes of the headsets disclosed above.

[0247] The example eye tracker sensor **3910** is used to track eye movement and/or the direction in which a user's eyes are directed. For example, the eye tracker sensor **3910** may be a camera or other sensor that is incorporated into an appendage that extends from the headset **3902** and is directed to one or

both of the user's eyes. In other examples, the eye tracker sensor **3910** may be a camera or other sensor on or near a computer, a television, a mobile phone screen or other location to gather data related to the user's eye movement. The eye tracker sensor **3910** may continuously record what the subject is seeing. In some examples, the eye tracker sensor is placed around the middle of the subject's eyebrows. Also, in some examples, the eye tracker sensor includes a monocular or binocular (e.g., one eye or two eye coverage) infra-red (IR) camera to track the pupil and/or corneal reflection positions to aid in determining a point of regard of the subject's viewpoint. In some examples, the eye tracker sensor **3910** incorporates and/or is used in conjunction with an accelerometer/attitude measurement system **3911**. Many mobile eye-tracking systems that are mounted to a subject's head are susceptible to erroneous measurements as the subject moves his or her head relative to the position he or she had during calibration of the system. The example accelerometer **3911** continuously tracks the relative eye position from calibration, which enhance the accuracy of the point-of-regard measurement from the eye-tracking sensor **3910**.

[0248] The eye track data may be synchronized with and/or otherwise used to corroborate the EEG data or otherwise may be used in conjunction with the EEG to determine a neurological state of the user. Eye movements provide a target of a user's attention allocation. For example, if the user is looking in the direction of a television and his or her EEG data indicates that he or she is in a state of engagement or attention, the eye track data and EEG data together demonstrate that the attention was likely directed to the television.

[0249] The example system of FIG. **39** also includes a database **3914** for local storage of raw data, processed data, result data, history logs, programming data from a media source, and/or any other type of data. The transmitter **3916** of the illustrated example communicates the data at any stage of processing and/or the results of the analysis from the headset **3902** to a remote data facility **3920** and/or an electrical device **3922**, as disclosed in more detail below.

[0250] In some example implementations, the system **3900** is used to collect audience measurement data. The example system **3900** determines if a user's neurological state indicates that the user is focused (e.g., engaged with the media) while watching a certain media. The program identifier **3906** identifies media to which the user is exposed. The program identification can be done with any technology, for example, the program can be identified by collecting audio codes and/or signatures using a microphone on the headset to collect audio signals as disclosed in Thomas, U.S. Pat. No. 5,481, 294. The program identifier **3906** collects data concerning the media, such as, for example, a television show, an advertisement, a movie, a news clip, radio program, a web page, or any other media and identifies the media (e.g., content or advertisement) based on the collected data and/or forwards the collected data to another device to perform the identification.

[0251] In the collection of audience measurement data, the example system **3900** gathers EEG data from the EEG sensors **3904** of the headset **3902**. The system gathers eye tracking data from the eye tracking sensor **3910** to determine which direction the user is gazing during the media broadcast. The attention evaluator **3912** uses data from the EEG sensor **3904** and the eye tracker sensor **3910** to determine if a user paying attention to the media. For example, if the EEG sensors **3904** detect brain waves (i.e., electrical activity) indicative of increased thought, and the eye tracking sensor **3910**

determines that the user is looking at the TV, the attention evaluator 3912 will output a signal that the user is focused and immersed in that particular media program being broadcast. However, if the program identifier 3906 determines a certain program is being presented, and the EEG sensors 3904 indicate decreasing brain activity, or if the eye tracker sensor 3910 determines the user is not looking at the TV, then the attention evaluator 3912 will output a signal that the user is not focused or immersed on that particular media program.

[0252] Data reflected of the user paying attention, the user not paying attention, or the user in a state of semi-involvement with the program and the identity of the program are storable in the database 3914 and transmittable by the transmitter 3916 to an output including, for example, a remote data facility 3920. Raw data, processed data, a history log or an indicator of audience measurement also may be transmitted to the remote data facility 3920 for collection. The remote data facility 3920 may be, for example, a marketing company, a broadcast company, an entertainment studio, a television network and/or any other organization that might benefit from or otherwise desire to know when users are and/or are not focused on broadcast programs and what those programs are. In some examples, the headset 3902 is communicatively coupled to the remote data facility 3920 via a communication channel 3924 such as common telephone line, a landline, an internet connection, radio waves, and/or any other communication technology capable of sending signals. This example allows broadcasting companies and/or marketing personnel to analyze which programs people are watching, when they are watching the programs and/or when they are focused during the broadcast.

[0253] In another example implementation, the example system 3900 and headset 3902 operate as a direct neural interface or brain-machine interface (BMI) that is to generate an input for an electrical device 3922 such as, for example, a television, a radio, a computer mouse, a computer keyboard, a remote control, a microwave, an application interface and/or other devices. The input signal for the electrical device 3922 is based on data from the EEG sensor 3904 and/or the eye tracker sensor 3910 of the headset 3902. For example, the eye tracker sensor 3910 determines that the user is gazing at a certain area of his/her computer and the EEG sensors 3904 detect electrical activity indicative of focus. The system 3900 used to control the electrical device 3922 uses specific EEG signatures that trigger control including, for example, signatures in the somatosensory system that are focal over the sensorimotor cortex contralateral to movement and include changes in mu (e.g., 10-14 Hz) and beta (e.g., 15-30 Hz) rhythms. Based on the EEG and eye tracking data, the remote action evaluator 3908 of the headset 3902 determines that the user wants to move his or her cursor (i.e., mouse) to a different region of the computer screen. The remote action evaluator 3908 sends a signal via the transmitter 3916 to the electrical device 3922 to move the cursor on the screen. In another example, the remote action evaluator 3908 analyzes data from the EEG sensor 3904 and determines that a user wants to change a volume level on the television. The remote action evaluator 3908 transmits a signal via the transmitter 3916 to the electrical device 3922 (i.e., the television or cable receiver) to change the volume level. In the example shown, the headset 3902 is communicatively coupled to the electrical device 3922 via a communication line 3926, which may be a hard wire or wireless communication technology such as, for example, any of the communication links discussed herein. In

some examples, the remote action evaluator develops signals to conduct a plurality of other functions, such as, for example, muting a television, changing a channel, powering a television, computer or other device on/off, opening a specific program on a computer, setting a microwave, making a musical selection, operating a remote control device, operating a stereo in an automobile, operating a light switch, answering a phone, operating a DVR (digital video recorder) and/or video-on-demand and/or any other function which typically involves the user pressing a button on a device or a remote control of the device. EEG signals including changes in somatosensory mu and beta rhythms are also used in other brain machine interface applications including, for example, driving a wheelchair, controlling a small robot, controlling exoskeletal devices on paralyzed limbs and/or other functions.

[0254] While example manner of implementing the system 3900 has been illustrated in FIG. 39, one or more of the elements, processes and/or devices illustrated in FIG. 39 may be combined, divided, re-arranged, omitted, eliminated and/or implemented in any other way. Further, the example program identifier 3906, the example remote action evaluator 3908, the example attention evaluator 3912, the example database 3914, the example transmitter 3916, the example remote data facility 3920, the example electrical device 3922 and/or, more generally, the example system 3900 of FIG. 39 may be implemented by hardware, software, firmware and/or any combination of hardware, software and/or firmware. Thus, for example, the example program identifier 3906, the example remote action evaluator 3908, the example attention evaluator 3912, the example database 3914, the example transmitter 3916, the example remote data facility 3920, the example electrical device 3922 and/or, more generally, the example system 3900 of FIG. 39 could be implemented by one or more circuit(s), programmable processor(s), application specific integrated circuit(s) (ASIC(s)), programmable logic device(s) (PLD(s)) and/or field programmable logic device(s) (FPLD(s)), etc. When any of the apparatus or system claims of this patent are read to cover a purely software and/or firmware implementation, at least one of the example program identifier 3906, the example remote action evaluator 3908, the example attention evaluator 3912, the example database 3914, the example transmitter 3916, the example remote data facility 3920 or the example electrical device 3922 are hereby expressly defined to include hardware and/or a tangible computer readable medium such as a memory, DVD, CD, etc. storing the software and/or firmware. Further still, the example system 3900 of FIG. 39 may include one or more elements, processes and/or devices in addition to, or instead of, those illustrated in FIG. 39, and/or may include more than one of any or all of the illustrated elements, processes and devices.

[0255] FIGS. 40-44 are flowcharts representative, at least in part, of example machine readable instructions that may be executed to implement the example headsets 100, 2300, 3400, 3812, 3902 and/or example systems 3600, 3700, 3800, 3900. In the examples of FIGS. 40-44, the machine readable instructions include a program for execution by a processor such as the processor 4512 shown in the example processing platform 4500 discussed below in connection with FIG. 45. The program may be embodied in software stored on a tangible computer readable medium such as a CD-ROM, a floppy disk, a hard drive, a digital versatile disk (DVD), or a memory associated with the processor 4512, but the entire

program and/or parts thereof could alternatively be executed by a device other than the processor **4512** and/or embodied in firmware or dedicated hardware. Further, although the example program is described with reference to the flowcharts illustrated in FIG. **40-44**, many other methods of implementing the example headsets **100**, **2300**, **3400**, **3812**, **3902** and/or example systems **3600**, **3700**, **3800**, **3900** may alternatively be used. For example, the order of execution of the blocks may be changed, and/or some of the blocks described may be changed, eliminated, or combined.

[**0256**] As mentioned above, the example processes of FIGS. **40-44** may be implemented, at least in part, using coded instructions (e.g., computer readable instructions) stored on a tangible computer readable medium such as a hard disk drive, a flash memory, a read-only memory (ROM), a compact disk (CD), a digital versatile disk (DVD), a cache, a random-access memory (RAM) and/or any other storage media in which information is stored for any duration (e.g., for extended time periods, permanently, brief instances, for temporarily buffering, and/or for caching of the information). As used herein, the term tangible computer readable medium is expressly defined to include any type of computer readable storage medium and to exclude propagating signals. Additionally or alternatively, the example processes of FIGS. **40-44** may be implemented, at least in part, using coded instructions (e.g., computer readable instructions) stored on a non-transitory computer readable medium such as a hard disk drive, a flash memory, a read-only memory, a compact disk, a digital versatile disk, a cache, a random-access memory and/or any other storage media in which information is stored for any duration (e.g., for extended time periods, permanently, brief instances, for temporarily buffering, and/or for caching of the information). As used herein, the term non-transitory computer readable medium is expressly defined to include any type of computer readable medium and to exclude propagating signals.

[**0257**] FIG. **40** is a flowchart illustrating an example process of analyzing EEG data (block **4000**) collected from the example headsets **100**, **2300**, **3400**, **3812**, **3902** and implemented by the example system **3600** of FIG. **36**. The example headsets **100**, **2300**, **3400**, **3812**, **3902** have a plurality of electrodes that contact the scalp of a subject to receive electrical signals from the subject's brain. The example process of analyzing EEG data (**4000**) includes reading the EEG signals from the electrodes (block **4002**). In the illustrated example, the signals are converted from an analog signal to a digital signal (block **4004**). In some examples, the analog-to-digital conversion takes place in a processing unit, such as, for example, the processing unit **3604** of the example system **3600**. In other examples, the analog-to-digital conversion takes place adjacent the electrodes within the headset to convert the signal as close to the source as possible.

[**0258**] In the illustrated example, the signals are conditioned (block **4006**) to improve the usefulness of the signals and the accessibility of the data contained therein. For example, as disclosed above, the conditioning may include amplifying the signals and/or filtering the signals (e.g., with a band pass filter). The signals are analyzed (block **4008**) to, for example, determine a mental state of the subject, a health condition, an engagement with media as an audience member, an input desire for an electrical device and/or otherwise in accordance with the teachings of this disclosure.

[**0259**] In the illustrated example, the signals are transmitted to an output (block **4010**), such as, for example, the output

3618 of the example system **3600**. Example modes of output are detailed above including, for example, sounding an alarm, displaying a message and/or other alert on a screen, issuing a report to a local and/or remote computer and/or any other suitable output. In addition, the output may include the wired or wireless communications detailed herein. After the output (block **4010**), the example process (**4000**) ends (block **4012**).

[**0260**] FIG. **41** is a flowchart illustrating an example process of improving EEG signal quality (block **4100**) collected, for example, from one or more of the example headsets **100**, **2300**, **3400**, **3812**, **3902** and implemented by the example system **3700** of FIG. **37**. The example headsets **100**, **2300**, **3400**, **3812**, **3902** include a plurality of electrodes (i.e., input channels) in contact with a head of a subject to receive electrical signals from the subject's brain. In some examples, the example process of improving signal quality (**4100**) is implemented by a processor located at the headset, such as, for example, in the second housing **128** of the headset **100** shown in FIGS. **1-3**. In other examples, the example process of improving signal quality (**4100**) occurs at a remote site, such as, for example, a handheld device, a local computer, a remote server and/or another suitable device.

[**0261**] The example process (**4100**) includes receiving signals from one or more input channel(s) (e.g., electrode(s)) (block **4102**). In some examples, the analyzer **3712** of the system **3700** receives the signals from the input channels for analysis. One or more properties of one or more of the signals are evaluated (block **4104**). For example, the signals are evaluated to determine signal strength, amplitude, signal-to-noise ratio, duration and/or other characteristics in accordance with the teachings of this disclosure.

[**0262**] In the illustrated example process (**4100**), one or more of the signals are conditioned (block **4106**) to improve signal quality. In some examples, conditioning the signals enhances the quality of the signals to an acceptable level such that the signal is usable. In other examples, signal conditioning may not provide sufficient improvement to a signal. The example process (**4100**) also includes selecting one or more signals to use, one or more signals to ignore and two or more signals to merge (block **4108**). As disclosed above, two or more signals may be merged by shorting one of the signals, coupling the electrodes providing the signals in parallel and/or averaging two or more signals, which lowers the impedance and improves signal quality as detailed above. The example process (**4100**) improves signal quality by selecting those signal(s) to use and by ignoring the signals of poor quality. After the selection of valuable and/or improved signals (block **4108**), the example processes of improving signal quality (**4100**) ends (block **4110**), and the signals and contained therein may be used in other processes such as, for example, the example analysis process (**4000**) of FIG. **40**.

[**0263**] FIG. **42** is a flowchart illustrating an example process of conducting at-home patient monitoring and treatment (block **4200**) using the example headsets **100**, **2300**, **3400**, **3812**, **3902** and implemented by the example system **3800** of FIG. **38**. The example headsets **100**, **2300**, **3400**, **3812**, **3902**, as disclosed above, have a plurality of electrodes that contact the scalp of a subject to receive electrical signals from the subject's brain. In some examples, the headsets **100**, **2300**, **3400**, **3812**, **3902** are worn by a subject for in-home monitoring, treatment and/or diagnosis of a medical condition, to detect a life-threatening situation, to ascertain patient com-

pliance with a prescribed medical regime and/or other suitable applications in accordance with the teachings of this disclosure.

[0264] The example process (4200) includes gathering signals from the electrodes or other suitable sensors (block 4202). As discussed above, the in-home patient monitoring system may incorporate not only the EEG readings from the example headsets, but also other biometric, neurological and/or physiological systems to monitor, treat and/or diagnosis medical conditions of an in-home patient. One or more of the signals are analyzed (block 4204) to determine a mental/physical state of the in-home patient. The signals may be analyzed, for example, with an analyzer or a processor such as the processor 134 disclosed above in the second housing 128 of the headset 100 shown in FIGS. 1-3. One or more of the signals may be conditioned and filtered in accordance with the teachings of this disclosure such as, for example, as disclosed in the example process (4000) of FIG. 40 and/or the example process (4100) of FIG. 41.

[0265] The example process (4200) determines whether the signals, an analysis of the signals or a notice related to the signals (e.g., such as an alarm and/or other suitable communication) should be sent to a remote facility (block 4206). The remote facility may be, for example, a doctor's office, a hospital, a clinic, a laboratory, an archive, a research facility and/or any other diagnostic facility. For example, if the signals indicate the occurrence of or an imminent occurrence of a heart attack, a stroke, an epileptic seizure and/or a fall, the example process (4200) determines that the signals, analysis or a notice should be sent to the remote facility (block 4206), and the example process (4200) sends the signals and/or notice or alarm to the remote facility (block 4208). After sending a communication to the remote facility (block 4208), the example process (4200) may end (block 4218) or continue monitoring of the subject by gathering signals from the sensors (block 4202).

[0266] If the example process (4200) determines that the signals, analysis or notice is not to be sent to a remote facility (block 4206), the example process (4200) determines if an output signal is to be produced (block 4210) (such as, for example, to warn a patient of a condition or remind him or her of an activity as disclosed in this patent). If an output signal is not to be produced (block 4210) (such as, for example, the signals indicate that the patient's condition is normal and/or the data is otherwise benign), the example process may end (block 4218) or continue monitoring of the subject by gathering signals from the sensors (block 4202).

[0267] If the example process (4200) determines that an output signal should be produced (block 4210), multiple types of outputs may be produced including any suitable output disclosed herein such as, for example, prompting a user for input (block 4212). As discussed above, patients often experience difficulty tracking and/or recalling their day-to-day activities. If the analysis indicates a certain spike in the reading occurred, the output signal (block 4210) may prompt the user for input (block 4212) as to what he/she was doing just prior to the spike.

[0268] In another example, the output signal (block 4210) administers auto-delivery of medicine (block 4214). For example, if a patient is diabetic, he/she may require continuous glucose and blood pressure monitoring. The process may automatically deliver a dosage of medicine to the patient if his/her reading requires (e.g., the signals indicate that a medical dosage is needed).

[0269] In another example, the output signal (block 4210) generates a signal (block 4216) such as a light, a sound, a display and/or any other output is used, for example, to alert a patient of a need to seek medical attention, to take a dosage of medicine, to start an activity, to stop an activity, to eat something and/or any other suitable warning and/or command. After producing one or more output(s) (blocks 4212, 4214, 4216), the example process (4200) may end (block 4218) or continue monitoring of the subject by gathering signals from the sensors (block 4202).

[0270] FIG. 43 is a flowchart illustrating an example process of evaluating a user's attention to a program and/or manipulating one or more electrical device(s) (block 4300) using the example headsets 100, 2300, 3400, 3812, 3900 and implemented by the example system 3900 of FIG. 39. The example headsets 100, 2300, 3400, 3812, 3900 include a plurality of electrodes to receive electrical signals from the brain for processing in accordance with the example process (4300). The example process (4300) illustrates the utility of EEG data and other physiological data (e.g., eye tracking data) for multiple purposes.

[0271] The example process (4300) includes gathering the signals from the EEG sensors (e.g., electrodes and/or input channels) (block 4302). Data from these signals is used to determine attention, memory, focus and/or other neurological states. The example process (4300) also includes gathering signals from an eye tracking sensor (block 4304). As discussed above, the eye tracking data may be used to corroborate the EEG data and both sets of data (e.g., EEG and eye tracking) may be used to determine a neurological state of a user (block 4306).

[0272] In an example implementation, the neurological state of a user (block 4306) is useful for audience measurement. For example, if a user is looking in the direction of a television and his or her EEG data indicates that he or she is in a state of engagement or attention, the eye tracking data and EEG data together demonstrate that the user is paying attention to the program. The example process (4300) also identifies what media or program the user is exposed to (block 4308). For example, the process (4300) may collect audio codes and/or signatures using a microphone and/or using any other device in accordance with the teachings of this disclosure. Based on the collected data, the example process (4300) identifies the program or media to which the user is exposed (block 4308). In the illustrated example, data reflecting whether the user is paying attention and to what program the user is or is not paying attention to, is transmitted to a remote facility (block 4310). As discussed above, the remote facility may be a marketing company, a broadcast company or any other organization that might benefit from or otherwise desire to know when users are and/or are not focused on broadcast programs. After the results are sent (block 4310), the example process (4300) may end (block 4316).

[0273] In another example implementation, the neurological state of a user (block 4306) is useful for evaluating whether a user wishes to manipulate a device (block 4312) including, for example, an electrical device, as disclosed above. For example, the EEG data and eye tracking data may indicate a user is gazing at a certain area of his/her computer and/or that the user has an increased level of focus. The example process (4300) determines that the user wants to control the device (e.g., computer) by, for example, opening a new application and/or moving a cursor. If the example process (4300) determines that a user wants to control a device

(block 4312), the example process (4300) transmits a signal to the device (block 4314) to effect the desired control of the device as disclosed above. After the control signal is transmitted (block 4314), the example process (4300) may end (block 4316).

[0274] FIG. 44 is a flowchart illustrating an example process of gathering and analyzing EEG data (block 4400) that may be implemented, for example, with any of the headsets and/or systems disclosed herein. The example process (4400) begins with placing a headset on a subject's head (block 4402). The example headset, as disclosed above, has a plurality of adjustable bands that extend over the head of a user. The headset may include three, four, five, or ten or more individual bands. In some examples, the headset may include less bands such as, for example, one or two. The bands are removably and rotatably coupled on each end to a first housing and a second housing. Each of the bands includes a plurality of electrodes for reading electrical activity along the scalp of a user. The headset may be oriented such that the first housing is near a right ear of a user and the second housing is near a left ear of the user. The user can rotate the individual bands toward theinion (the projection of the occipital bone) or the nasion (the intersection of the frontal bone and two nasal bones) to position the electrodes in specific locations for measuring electrical activity (block 4404). Each of the bands also comprises an elastic strap. The user may adjust the elastic straps on the bands to tighten the bands and press the electrodes on the bands down toward and against the user's head (block 4406). The user may tighten a back strap to secure the headset on the user's head (block 4408).

[0275] The example process (4400) also includes reading EEG data such as, for example, from one of more of the electrode(s) disclosed above (block 4410). Raw signals from the electrodes may then be conditioned (block 4412) with hardware, firmware and/or software components, such as, an A/D converter, an amplifier and/or one or more filters as disclosed above. In some examples, one or more of the conditioning components may be incorporated into a housing on a headset, into the individual adjustable bands, at each individual electrode and/or at a remote processor. In some example implementations of the example process (4400), a user determines if it is desirable to rotate the headset 90° (or any other suitable angle) for additional or alternative EEG data (block 4414). With a rotated headset, the bands traverse from the forehead to the back of the head. Such an orientation may be desired, for example, to obtain midline readings. If the user wishes to acquire additional data in the orthogonal position (block 4414), he or she rotates the headset 90° (block 4416) and repositions and adjusts the bands as explained above (blocks 4402-4408). With the headset positioned for the desired reading (block 4414) the conditioned signals are analyzed (block 4418).

[0276] The example process (4400) also includes determining if one or more of the electrode(s) needs to be or should be adjusted (block 4420). An electrode should be adjusted, for example, to obtain a clearer signal. If one or more of the electrode(s) are to be adjusted, the example process (4400) includes determining if the adjustment is to a physical adjustment or a non-physical adjustment (4422). If the adjustment is a physical adjustment (4422), control of the example process (4400) returns to block 4404, and the appropriate band(s) are rotated into position and/or the elongated strap(s) or straps are adjusted (blocks 4406-4408). If the electrode(s) are to be non-physically adjusted (4422), the example process (4400)

includes virtually moving and/or shorting one or more of the electrode(s) (block 4424), as detailed above. With the adjusted electrode(s), the example process (4400) returns to continue to read the EEG signal (block 4410), and the example process (4400) continues.

[0277] If the electrode(s) do not need to be further adjusted (block 4424), then the signals are analyzed to produce an output assessment or mental picture (block 4426). As disclosed above, the output assessment or mental picture may determine, for example, the neurological state of the person. For example, as provided in examples disclosed above, the EEG data includes multiple frequency bands, which can be analyzed to determine, for example, if person has high concentration, is sleeping, is depressed, is happy, is calm and/or any other emotional and/or neurological state as disclosed above. The output assessment/mental picture provides insights into the thoughts, emotions and/or health of the person.

[0278] The example method 4400 also includes determining if the output is to be used with one or more additional application(s) (block 4428). If the output is to be used with one or more additional application(s) such as, for example, medical applications, audience measurements, remote device control and/or any other suitable application as disclosed herein, such applications are performed (block 4430). The example process (4400) also determines if monitoring of EEG data should continue (block 4432). If further monitoring is to be conducted, control of the method returns to block 4410, and EEG signal data is read. If further monitoring is not to be conducted, then the example method 4400 ends (block 4434).

[0279] FIG. 45 is a block diagram of an example processing platform 4500 capable of executing the one or more of the instructions of FIGS. 40-44 to implement one or more portions of the apparatus and/or systems of FIGS. 1, 23, 34 and 36-39. The processing platform 4500 can be, for example a processor in a headset, a server, a personal computer, and/or any other type of computing device.

[0280] The system 4500 of the instant example includes a processor 4512. For example, the processor 4512 can be implemented by one or more microprocessors or controllers from any desired family or manufacturer.

[0281] The processor 4512 includes a local memory 4513 (e.g., a cache) and is in communication with a main memory including a volatile memory 4514 and a non-volatile memory 4516 via a bus 4518. The volatile memory 4514 may be implemented by Synchronous Dynamic Random Access Memory (SDRAM), Dynamic Random Access Memory (DRAM), RAMBUS Dynamic Random Access Memory (RDRAM) and/or any other type of random access memory device. The non-volatile memory 4516 may be implemented by flash memory and/or any other desired type of memory device. Access to the main memory 4514, 4516 is controlled by a memory controller.

[0282] The processing platform 4500 also includes an interface circuit 4520. The interface circuit 4520 may be implemented by any type of interface standard, such as an Ethernet interface, a universal serial bus (USB), and/or a PCI express interface.

[0283] One or more input devices 4522 are connected to the interface circuit 4520. The input device(s) 4522 permit a user to enter data and commands into the processor 4512. The input device(s) can be implemented by, for example, an elec-

trode, a physiological sensor, a keyboard, a mouse, a touch-screen, a track-pad, a trackball, isopoint and/or a voice recognition system.

[0284] One or more output devices 4524 are also connected to the interface circuit 4520. The output devices 4524 can be implemented, for example, by display devices (e.g., a liquid crystal display and/or speakers). The interface circuit 4520, thus, typically includes a graphics driver.

[0285] The interface circuit 4520 also includes a communication device (e.g., transmitter 3616, 3916) such as a modem or network interface card to facilitate exchange of data with external computers via a network 4526 (e.g., an Ethernet connection, a digital subscriber line (DSL), a telephone line, coaxial cable, a cellular telephone system, etc.).

[0286] The processing platform 4500 also includes one or more mass storage devices 4528 for storing software and data. Examples of such mass storage devices 4528 include floppy disk drives, hard drive disks, compact disk drives and digital versatile disk (DVD) drives. The mass storage device 4628 may implement the local storage device 3612, 3822, 3914.

[0287] The coded instructions 4532 of FIGS. 40-44 may be stored in the mass storage device 4528, in the volatile memory 4514, in the non-volatile memory 4516, and/or on a removable storage medium such as a CD or DVD.

[0288] Although certain example apparatus have been described herein, the scope of coverage of this patent is not limited thereto. On the contrary, this patent covers all methods, apparatus, and articles of manufacture fairly falling within the scope of the appended claims either literally or under the doctrine of equivalents.

What is claimed is:

1. A method comprising:

evaluating, by executing an instruction with a processor, a first property of a first neurological signal;
 determining, by executing an instruction with the processor, if the first neurological signal complies with a quality threshold based on the first property;
 evaluating, by executing an instruction with the processor, a second property of a second neurological signal;
 determining, by executing an instruction with the processor, if the second neurological signal complies with the quality threshold based on the second property;
 conditioning the first neurological signal if the first neurological signal does not comply with the quality threshold to obtain a third neurological signal;
 conditioning the second neurological signal if the second neurological signal does not comply with the quality threshold to obtain a fourth neurological signal;
 evaluating, by executing an instruction with the processor, a third property of the third neurological signal;
 determining, by executing an instruction with the processor, if the third neurological signal complies with the quality threshold based on the third property;
 evaluating, by executing an instruction with the processor, a fourth property of the fourth neurological signal;
 determining, by executing an instruction with the processor, if the fourth neurological signal complies with the quality threshold based on the fourth property;
 selecting, by executing an instruction with the processor, based on respective compliance with the quality threshold, a first one of the first neurological signal, the second neurological signal, the third neurological signal or the fourth neurological signal to at least one of use for additional analysis, to ignore, or to merge with a second one

of the first neurological signal, the second neurological signal, the third neurological signal or the fourth neurological signal.

2. The method of claim 1, wherein the method occurs on a headset used to gather the first neurological signal and the second neurological signal.

3. The method of claim 1, wherein the first, second, third and fourth properties include at least one of a strength, an amplitude, a signal-to-noise ratio or a duration of the respective first, second, third or fourth neurological signal.

4. The method of claim 1, wherein the quality threshold includes an absolute threshold, a spectral threshold, a ramp-rate threshold or a low-activity threshold.

5. The method of claim 1, wherein the conditioning includes at least one of amplifying the first or second neurological signal or filtering the first or second neurological signal.

6. The method of claim 1, wherein the ignoring or the merging is conducted by a switching circuit communicatively coupled to a first channel through which the first neurological signal is gathered and a second channel through which the second neurological signal is gathered.

7. The method of claim 1, wherein the selecting virtually relocates a sensor to a stronger signal gathering position while maintaining the sensor in a same physical position.

8. A tangible machine accessible storage medium comprising instructions that, when executed, cause a machine to at least:

evaluate a first property of a first neurological signal;
 determine if the first neurological signal complies with a quality threshold based on the first property;
 evaluate a second property of a second neurological signal;
 determine if the second neurological signal complies with the quality threshold based on the second property;
 condition the first neurological signal if the first neurological signal does not comply with the quality threshold to obtain a third neurological signal;
 condition the second neurological signal if the second neurological signal does not comply with the quality threshold to obtain a fourth neurological signal;
 evaluate a third property of the third neurological signal;
 determine if the third neurological signal complies with the quality threshold based on the third property;
 evaluate a fourth property of the fourth neurological signal;
 determine if the fourth neurological signal complies with the quality threshold based on the fourth property;
 select, based on respective compliance with the quality threshold, a first one of the first neurological signal, the second neurological signal, the third neurological signal or the fourth neurological signal to at least one of use for additional analysis, to ignore, or to merge with a second one of the first neurological signal, the second neurological signal, the third neurological signal or the fourth neurological signal.

9. The tangible machine accessible storage medium of claim 8, wherein the storage medium is disposed within a headset device used to gather the first neurological signal and the second neurological signal.

10. The tangible machine accessible storage medium of claim 8, wherein the first, second, third and fourth properties include at least one of a strength, an amplitude, a signal-to-noise ratio or a duration of the respective first, second, or fourth neurological signal.

11. The tangible machine accessible storage medium of claim 8, wherein the quality threshold includes an absolute threshold, a spectral threshold, a ramp-rate threshold or a low-activity threshold.

12. The tangible machine accessible storage medium of claim 8, wherein the instructions further cause the machine to condition one or more of the first neurological signal or the second neurological signal by at least one of amplifying the first or second neurological signal or filtering the first or second neurological signal.

13. The tangible machine accessible storage medium of claim 8, wherein the instructions further cause the machine to ignore one or more of the first, second, third or fourth neurological signals or merge two or more of the first, second, third or fourth neurological signals by actuating a switching circuit communicatively coupled to a first channel through which the first neurological signal is gathered and a second channel through which the second neurological signal is gathered.

14. The tangible machine accessible storage medium of claim 8, wherein the selecting virtually relocates a sensor to a stronger signal gathering position while maintaining the sensor in a same physical position.

15. A system comprising:

a headset including to gather a first neurological signal and a second neurological signal from a brain of a subject;

an evaluator to:

evaluate a first property of the first neurological signal;

determine if the first neurological signal complies with a quality threshold based on the first property;

evaluate a second property of the second neurological signal;

determine if the second neurological signal complies with the quality threshold based on the second property;

a conditioner to:

condition the first neurological signal if the first neurological signal does not comply with the quality threshold to obtain a third neurological signal; and

condition the second neurological signal if the second neurological signal does not comply with the quality threshold to obtain a fourth neurological signal;

the evaluator further to:

evaluate a third property of the third neurological signal; determine if the third neurological signal complies with the quality threshold based on the third property;

evaluate a fourth property of the fourth neurological signal; and

determine if the fourth neurological signal complies with the quality threshold based on the fourth property; and

a selector to select, based on respective compliance with the quality threshold, a first one of the first neurological signal, the second neurological signal, the third neurological signal or the fourth neurological signal to at least one of use for additional analysis, to ignore, or to merge with a second one of the first neurological signal, the second neurological signal, the third neurological signal or the fourth neurological signal.

16. The system of claim 15, wherein the evaluator, the conditioner and the selector are disposed within the headset.

17. The system of claim 15, wherein the first, second, third and fourth properties include at least one of a strength, an amplitude, a signal-to-noise ratio or a duration of the respective first, second, third or fourth neurological signal.

18. The system of claim 15, wherein the quality threshold includes an absolute threshold, a spectral threshold, a ramp-rate threshold or a low-activity threshold.

19. The system of claim 15, wherein the conditioner is to condition at least one of the first or second neurological signal by at least one of amplifying the first or second neurological signal or filtering the first or second neurological signal.

20. The system of claim 15 further including a switching circuit selectively communicatively coupled to a first channel to gather the first neurological signal and selectively communicatively coupled to a second channel to gather the second neurological signal to at least one of ignore one or more of the first, second, third or fourth neurological signals or merge two or more of the first, second, third or fourth neurological signals.

* * * * *

专利名称(译)	收集和分析脑电图数据的系统和方法		
公开(公告)号	US20160166169A1	公开(公告)日	2016-06-16
申请号	US15/044488	申请日	2016-02-16
[标]申请(专利权)人(译)	尼尔森(美国)有限公司		
申请(专利权)人(译)	尼尔森公司 (美国) 有限责任公司		
当前申请(专利权)人(译)	尼尔森公司 (美国) 有限责任公司		
[标]发明人	BADOWER YAKOB GURUMOORTHY RAMACHANDRAN PRADEEP A K KNIGHT ROBERT T		
发明人	BADOWER, YAKOB GURUMOORTHY, RAMACHANDRAN PRADEEP, A. K. KNIGHT, ROBERT T.		
IPC分类号	A61B5/0476 A61B5/00 A61B5/04		
CPC分类号	A61B5/0476 A61B5/6803 A61B5/04012 A61B5/00 A61B5/0006 A61B5/0478 A61B5/048 A61B5/165 A61B5/6831 A61B5/7203 A61B2562/0209 A61B2562/182 A61B5/163 A61B2562/0215		
优先权	61/684640 2012-08-17 US		
外部链接	Espacenet USPTO		

摘要(译)

本文公开了示例性方法，其包括经由包括两个或更多个可独立调节的带的装置从受试者获得脑电图 (EEG) 数据，每个带具有多个电极以检测来自受试者的脑的脑电图数据，每个带可相对于相邻带选择性地旋转，并且每个带可选择性地压缩以增加电极抵靠受试者头部的力。该示例方法还包括将EEG数据转换为数字EEG信号并调节数字EEG信号。另外，该示例方法包括使用一个或多个分析协议分析数字EEG信号以确定对象的心理特征并将心理特征发送到输出设备。

