



US 20160113712A1

(19) **United States**

(12) **Patent Application Publication**
Cheung et al.

(10) **Pub. No.: US 2016/0113712 A1**
(43) **Pub. Date: Apr. 28, 2016**

(54) **MEDICAL DEVICES WITH A FLEXIBLE ELECTRODE ASSEMBLY COUPLED TO AN ABLATION TIP**

(71) Applicant: **Boston Scientific Scimed Inc.**, Maple Grove, MN (US)

(72) Inventors: **Desmond Cheung**, San Jose, CA (US);
John C. Potosky, San Jose, CA (US);
Andrew T. Marecki, Shrewsbury, MA (US);
Isaac J. Kim, San Jose, CA (US);
Mark D. Mirigian, San Jose, CA (US)

(21) Appl. No.: **14/922,023**

(22) Filed: **Oct. 23, 2015**

Related U.S. Application Data

(60) Provisional application No. 62/068,334, filed on Oct. 24, 2014.

Publication Classification

(51) **Int. Cl.**
A61B 18/14 (2006.01)
A61B 5/00 (2006.01)
A61B 5/042 (2006.01)
(52) **U.S. Cl.**
CPC *A61B 18/1492* (2013.01); *A61B 5/0422* (2013.01); *A61B 5/6852* (2013.01); *A61B 2018/00351* (2013.01)

(57) **ABSTRACT**

Medical devices and methods for making and using medical devices are disclosed. An example medical device may include a catheter for use in cardiac mapping and/or ablation. The catheter may include an elongate catheter shaft having a distal ablation electrode region capable of ablating tissue. An electrode assembly may be coupled to the distal ablation electrode region. The electrode assembly may include a flexible circuit having one or more electrodes disposed thereon.

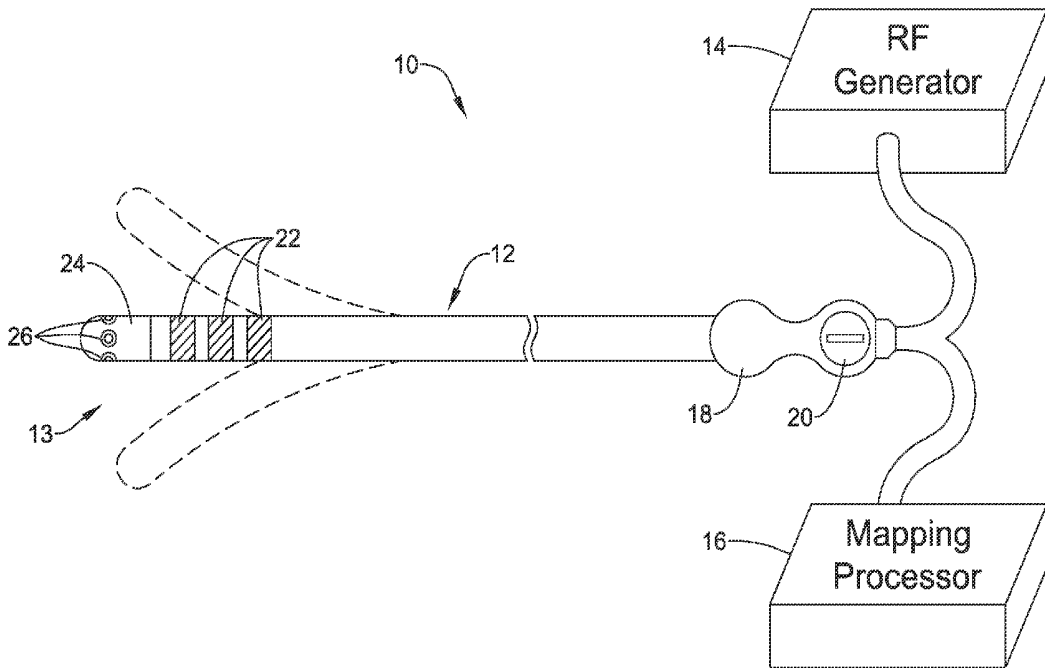

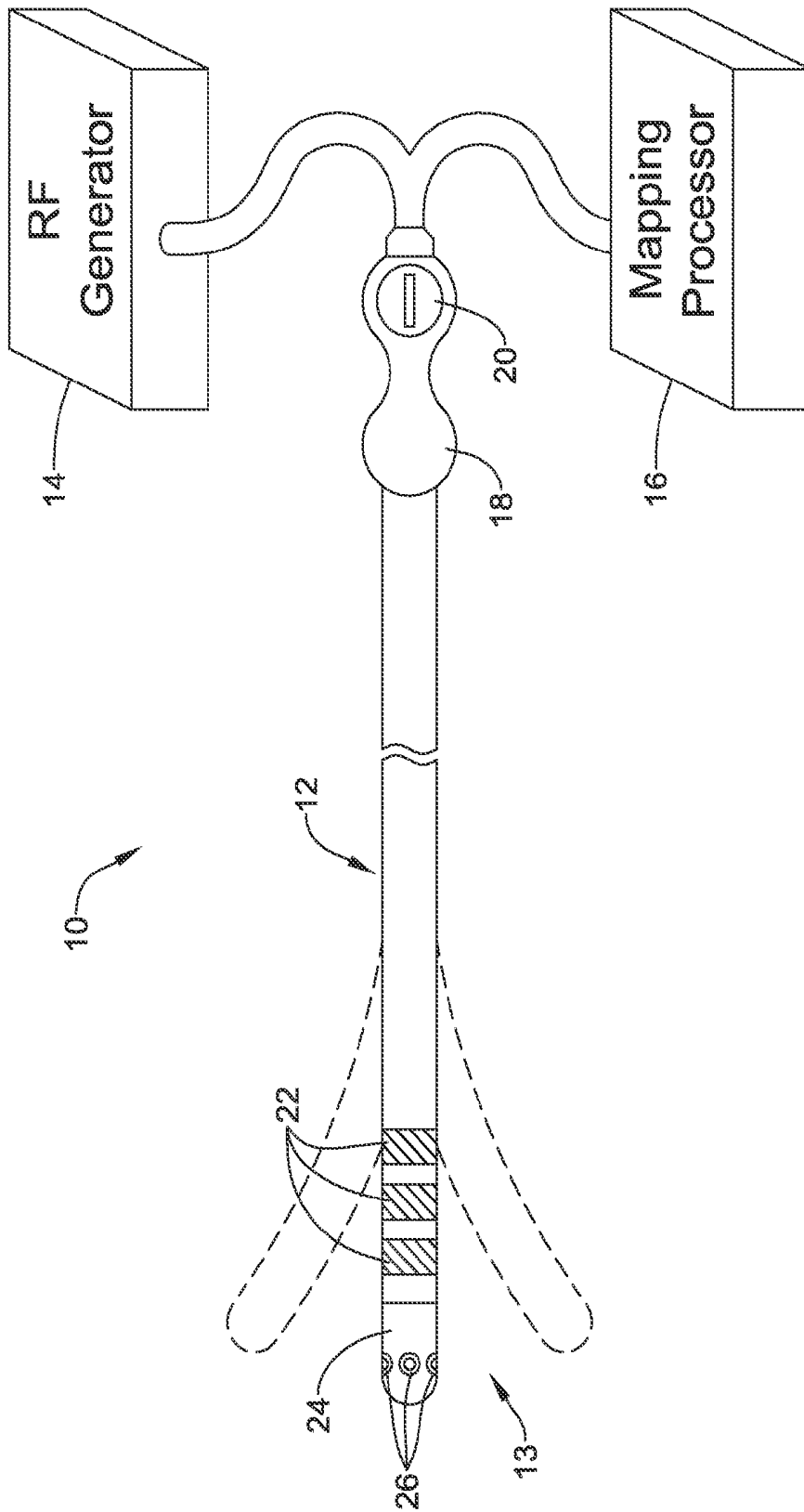

FIG. 1

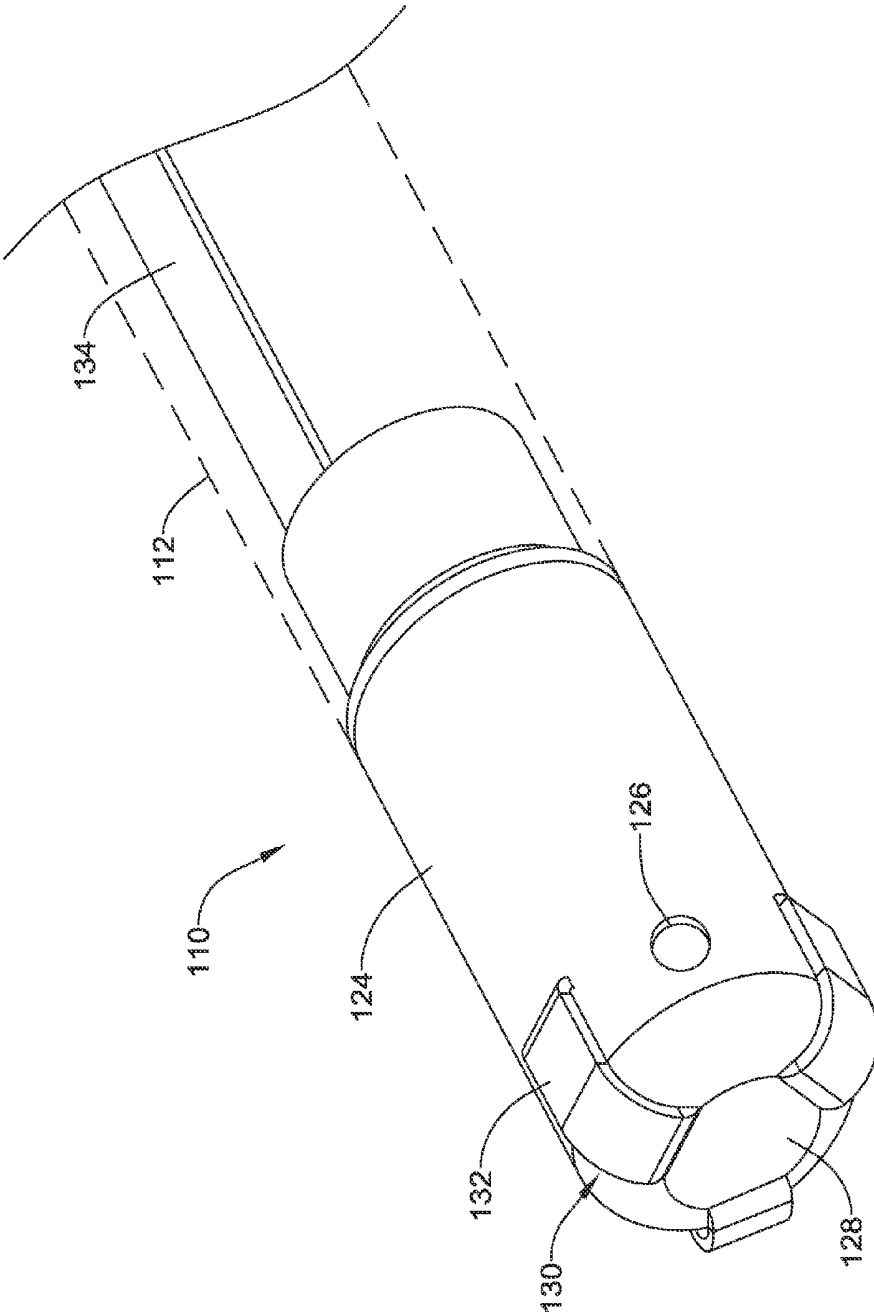

FIG. 2

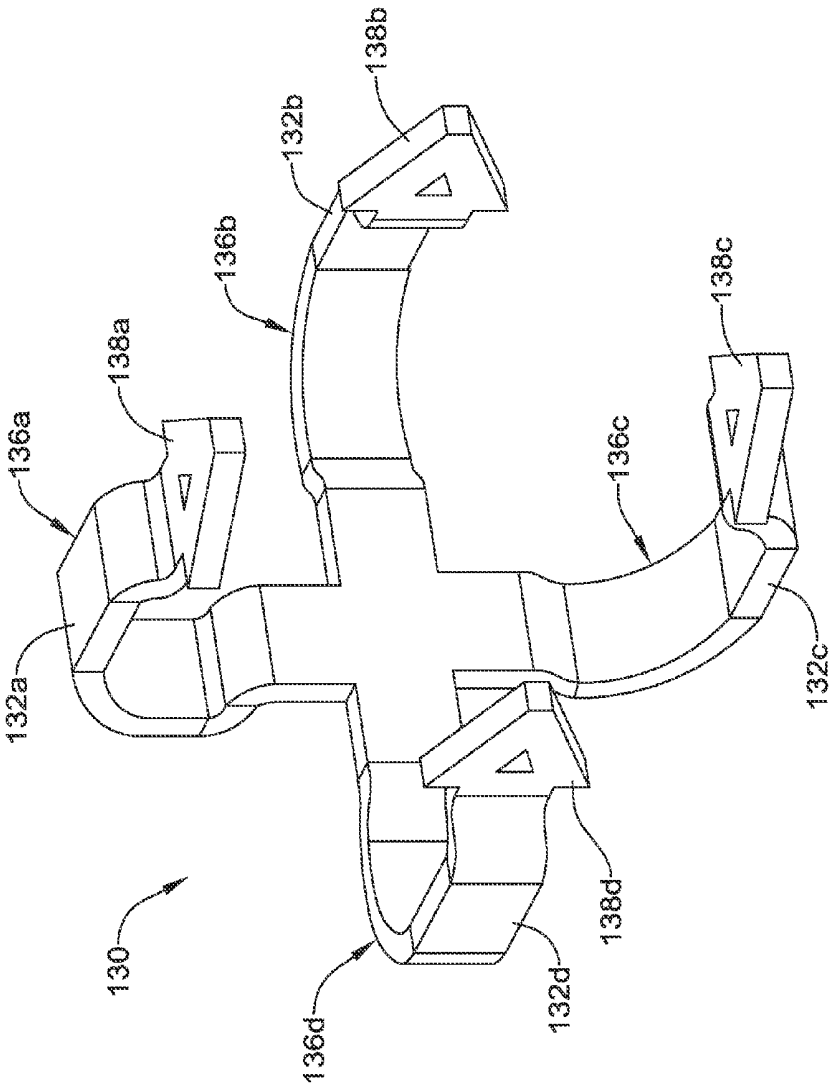

FIG. 3

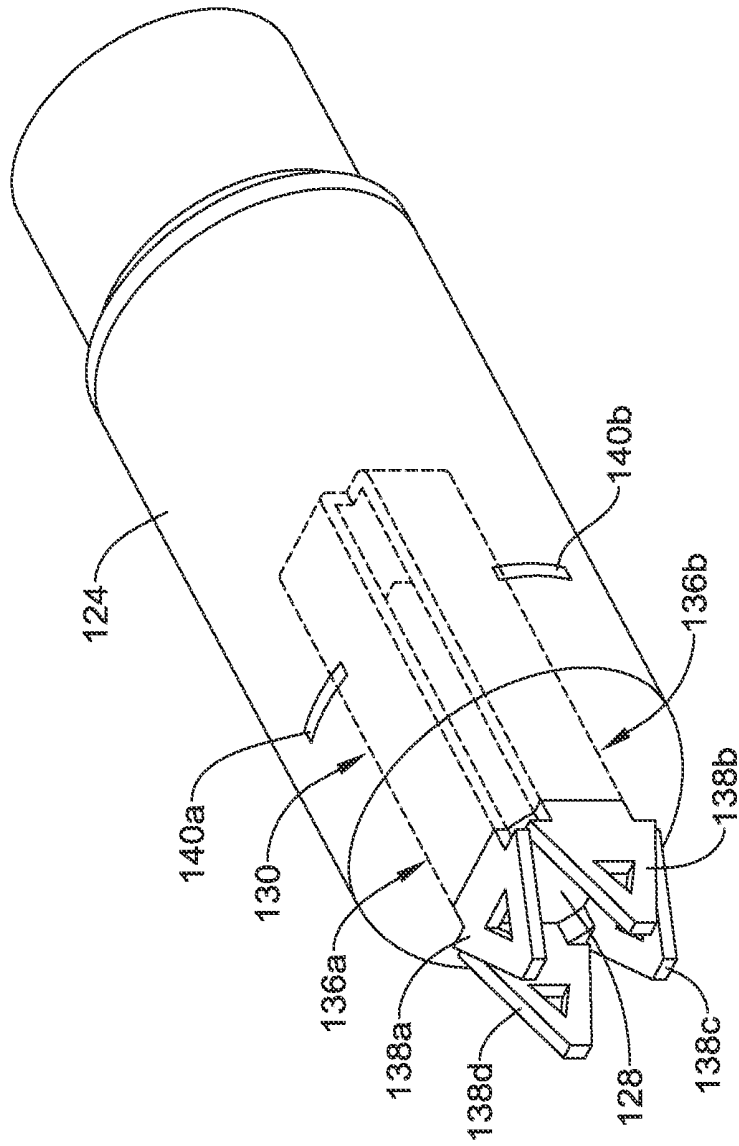

FIG. 4

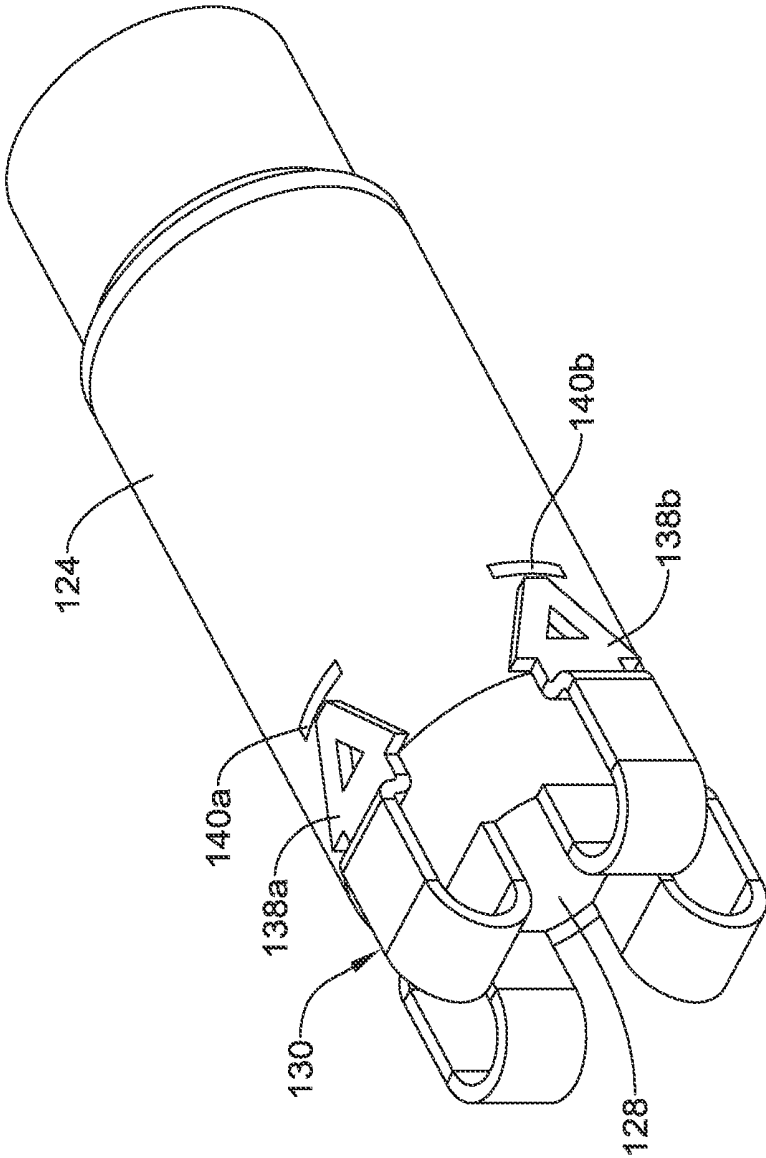

FIG. 5

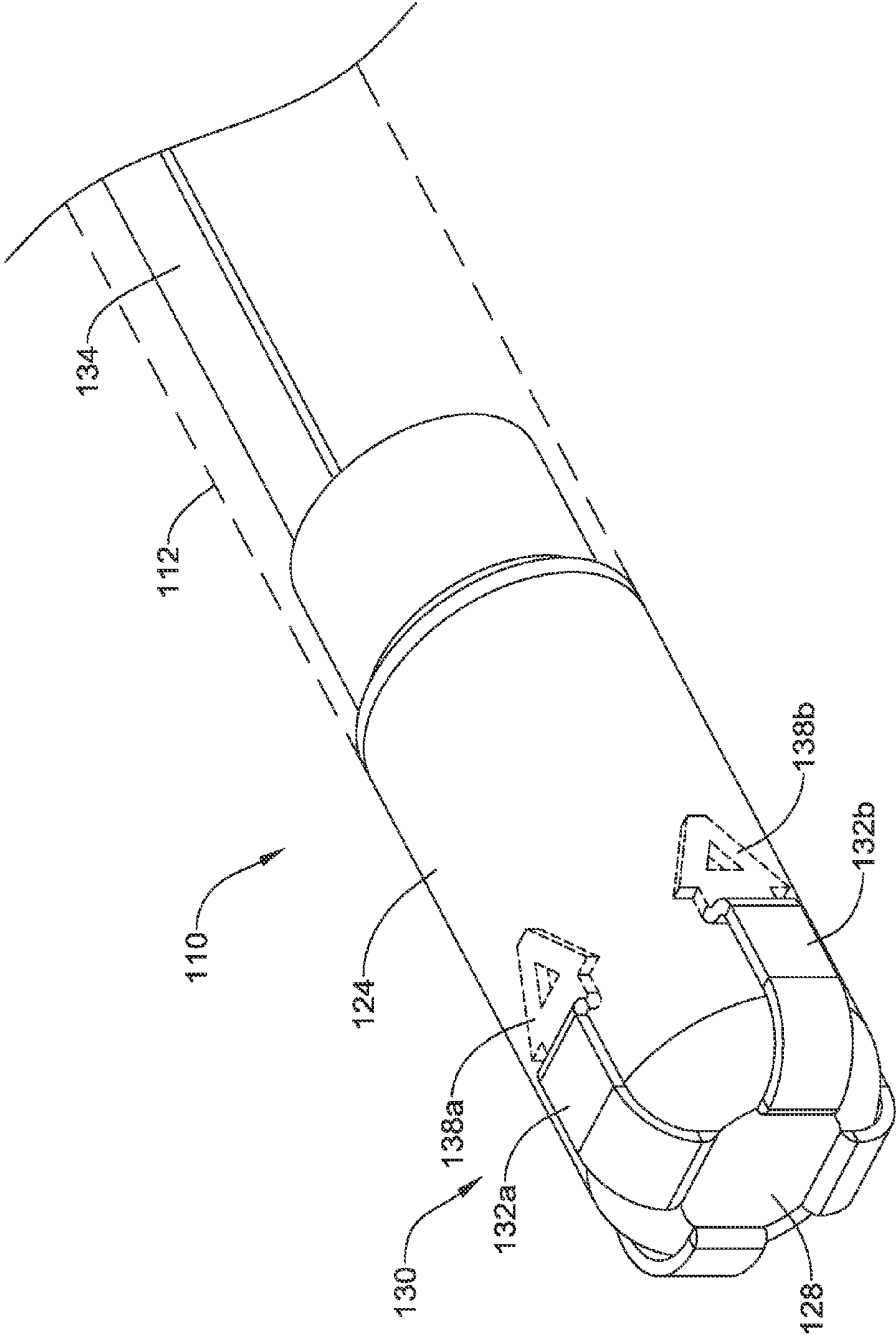

FIG. 6

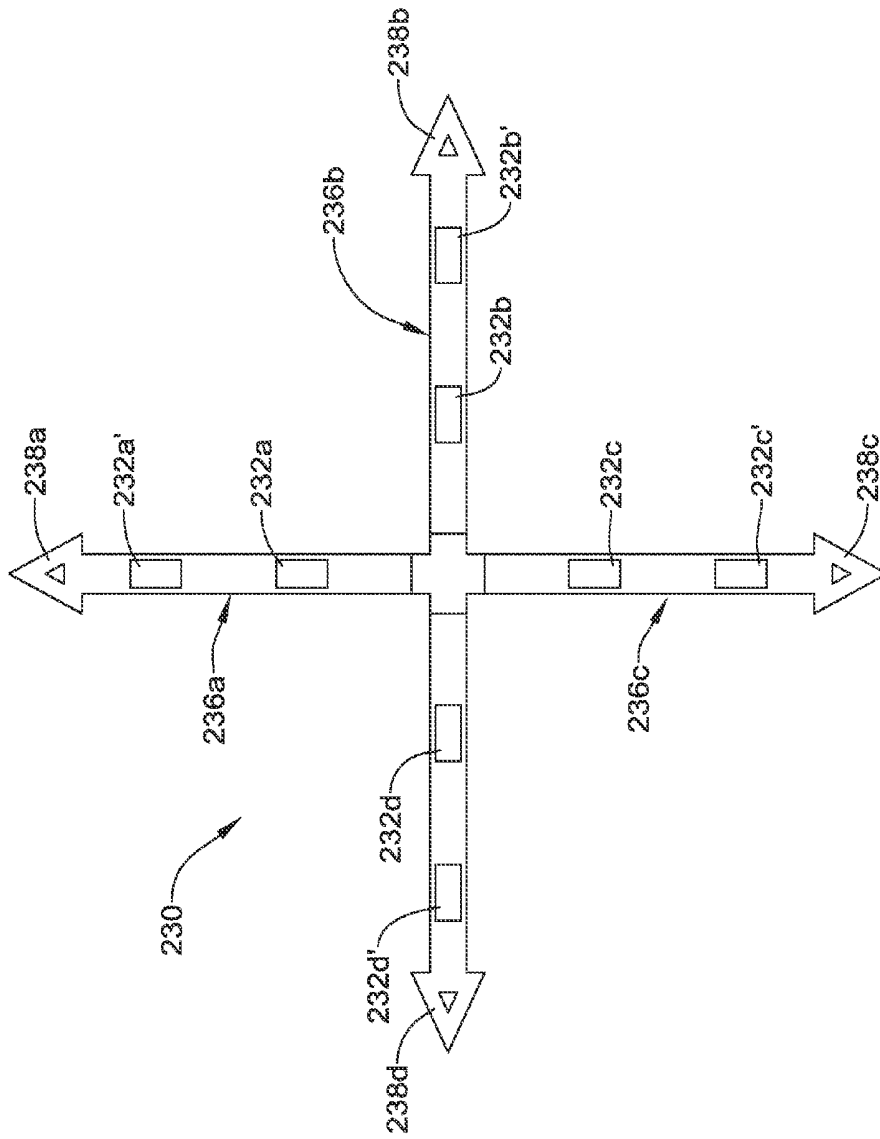

FIG. 7

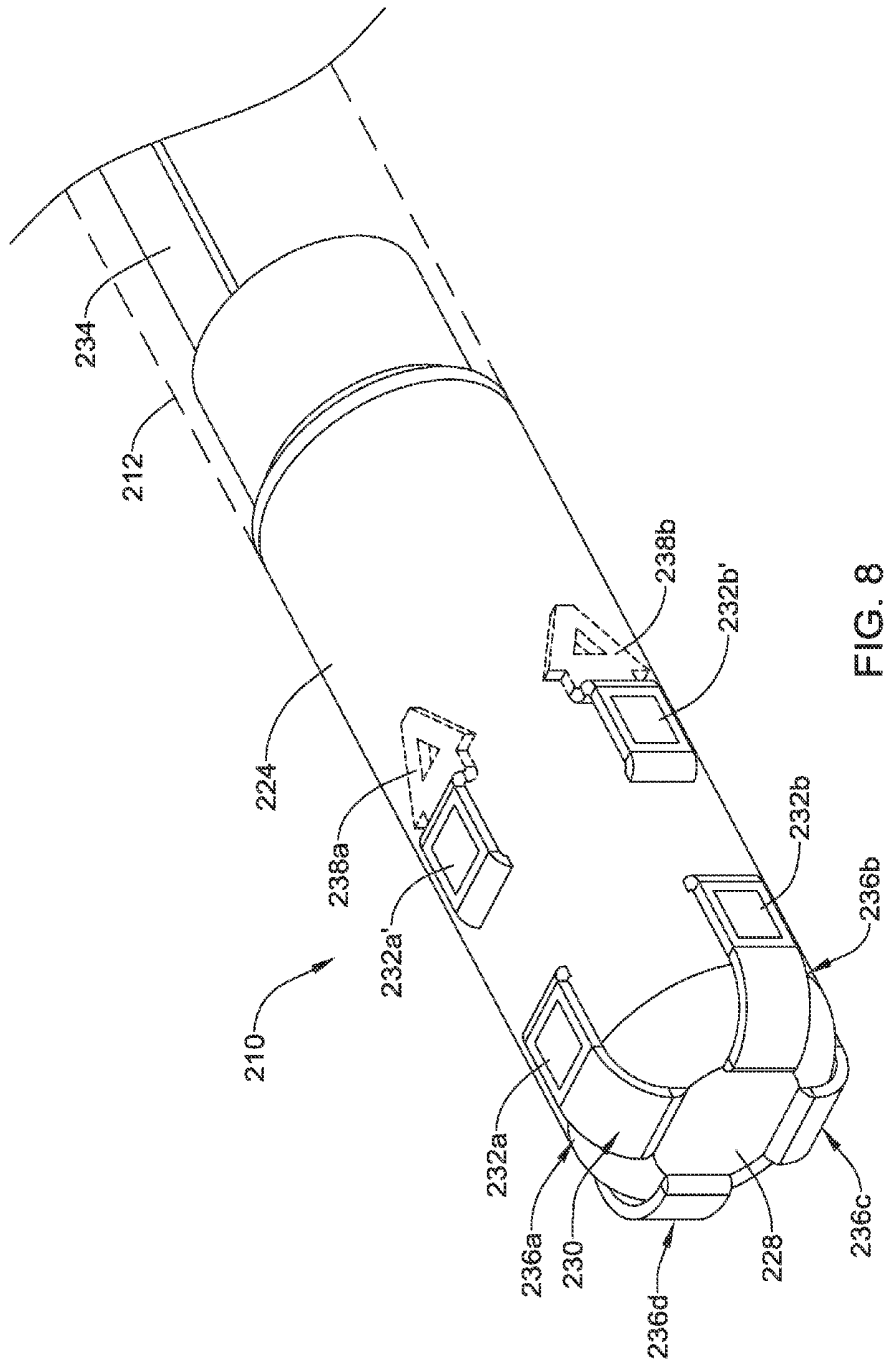

FIG. 8

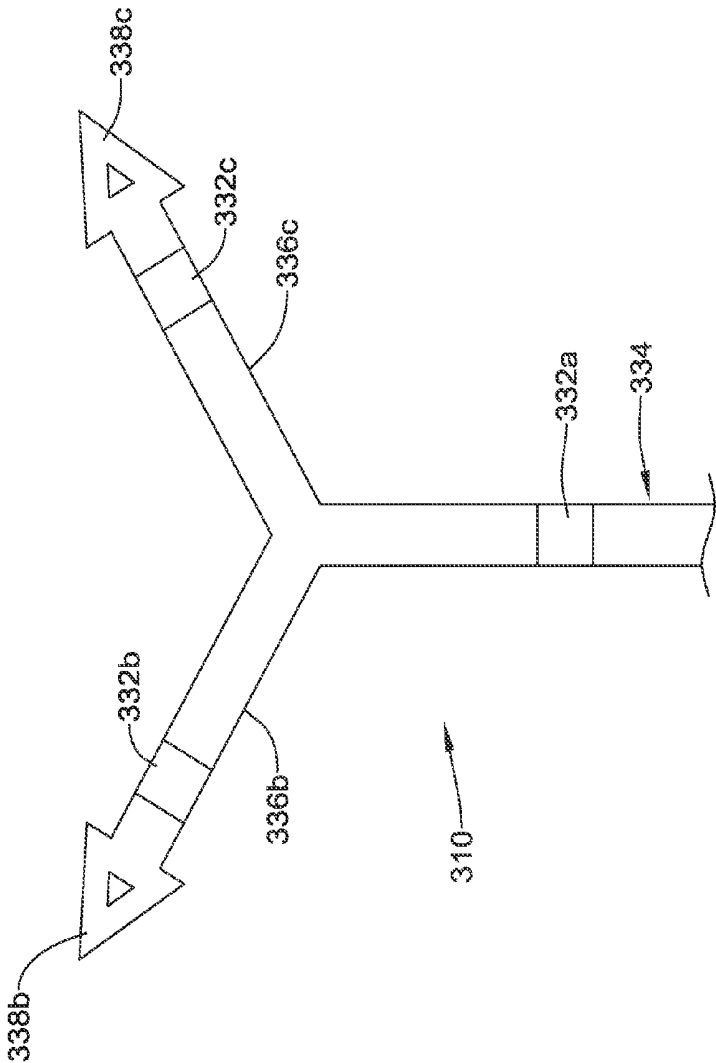

FIG. 9

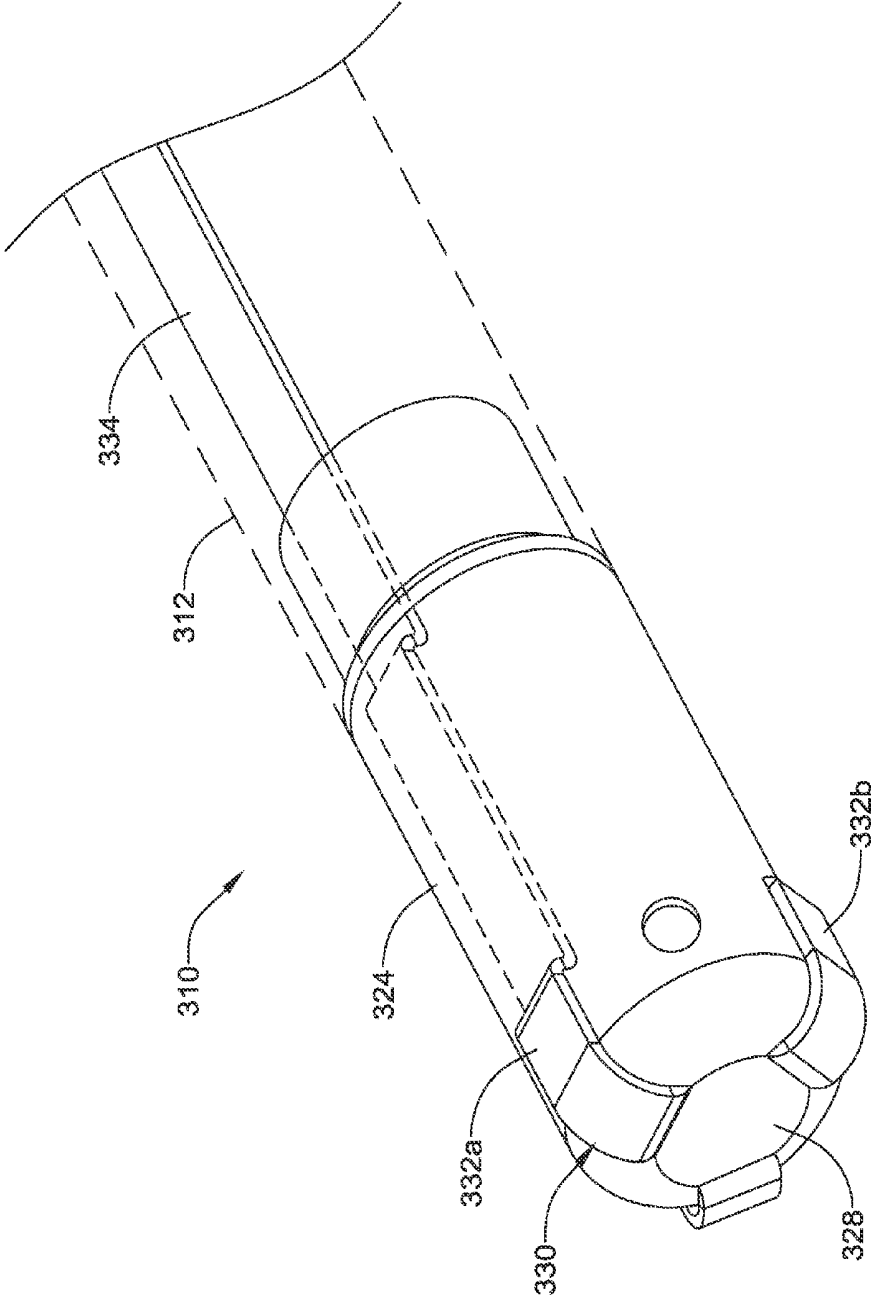

FIG. 10

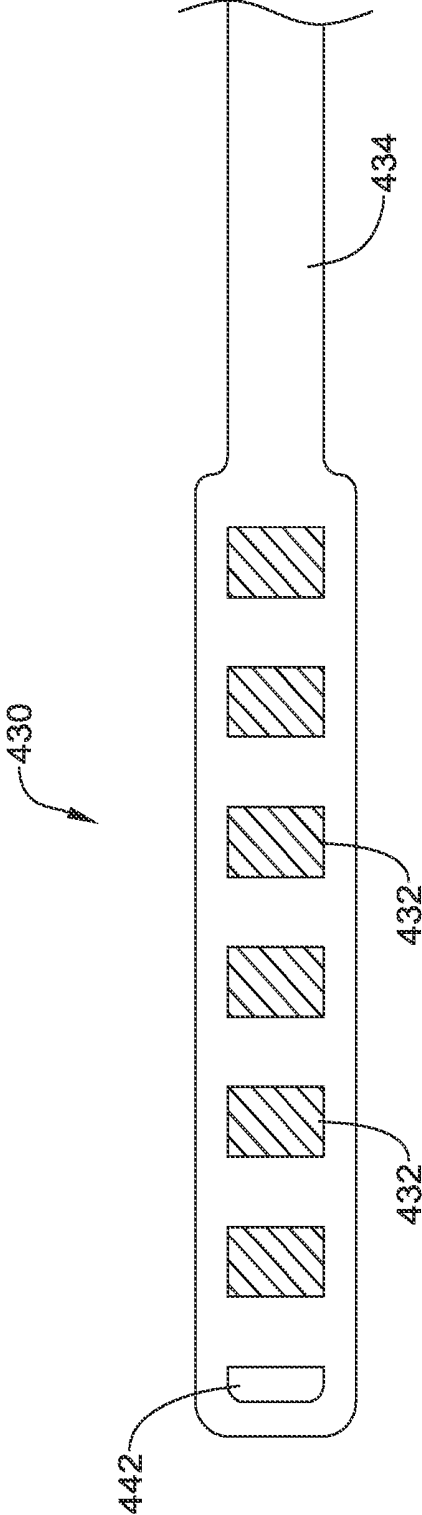

FIG. 11

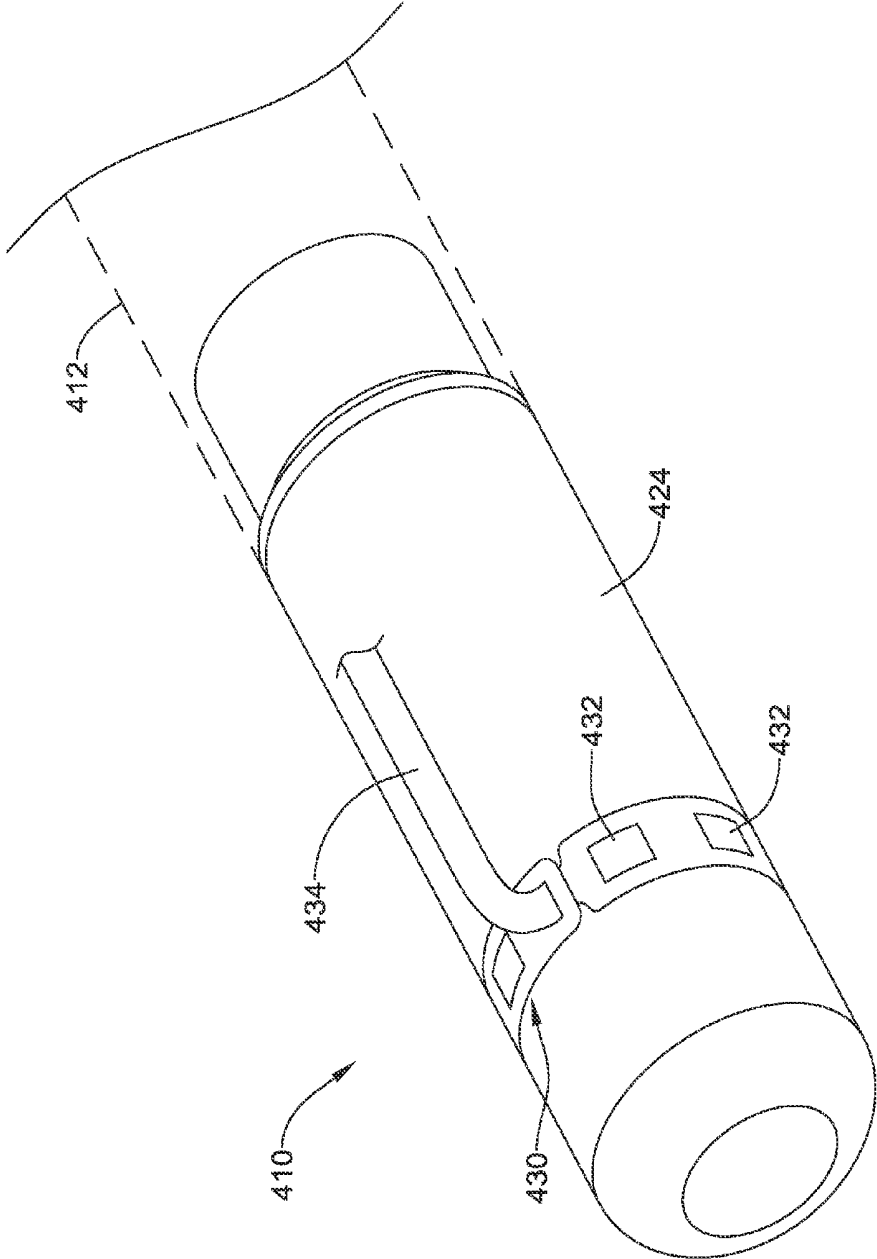

FIG. 12

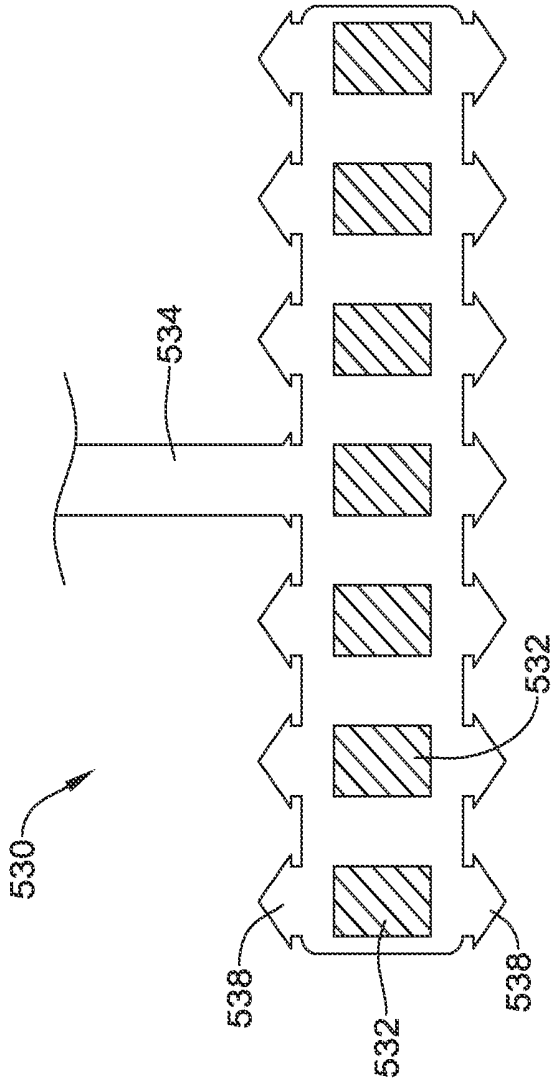

FIG. 13

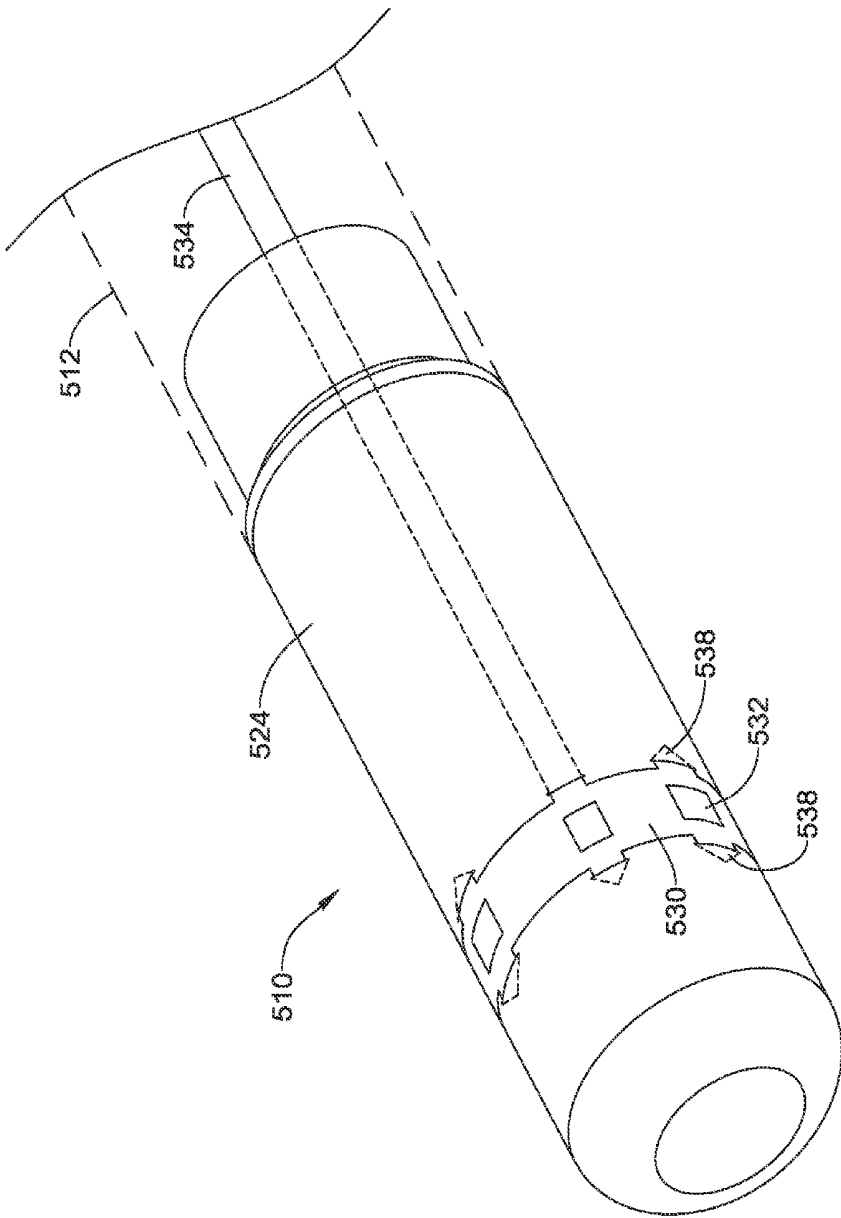

FIG. 14

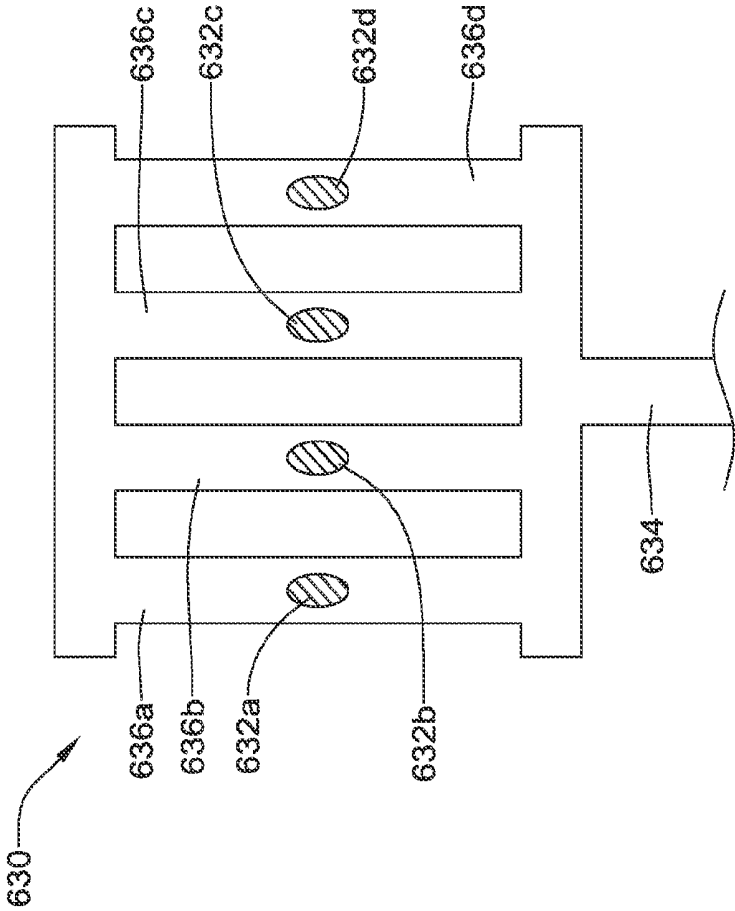
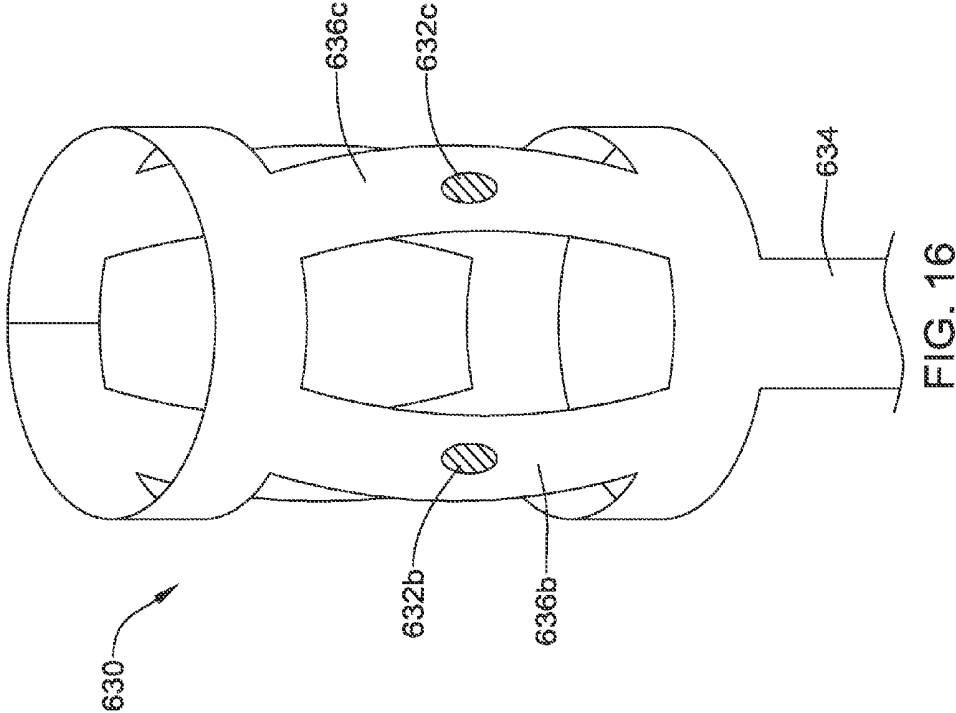

FIG. 15



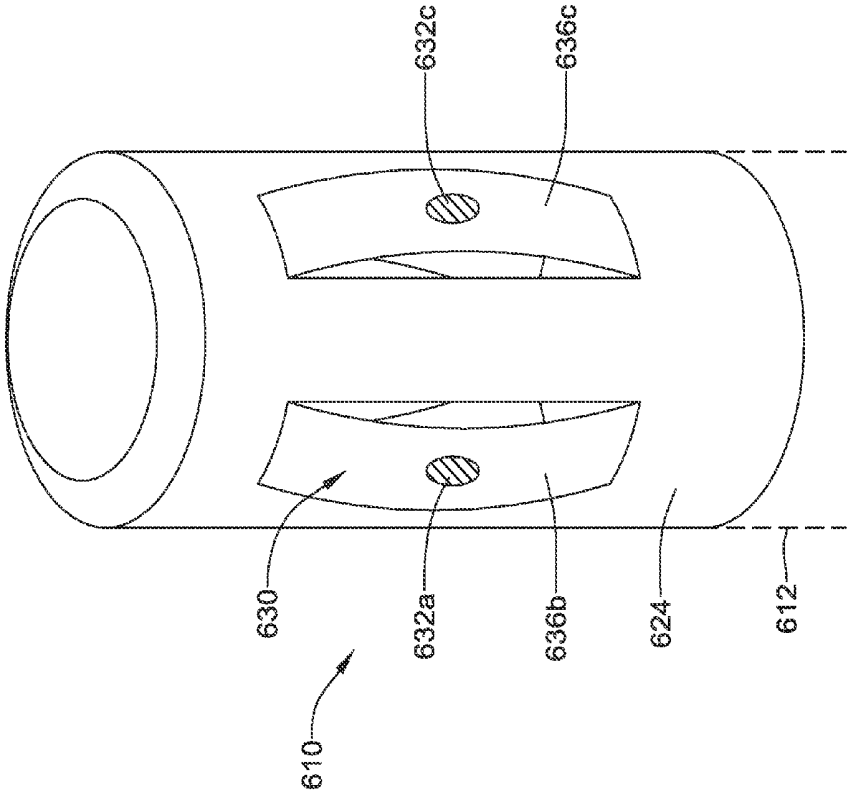

FIG. 17

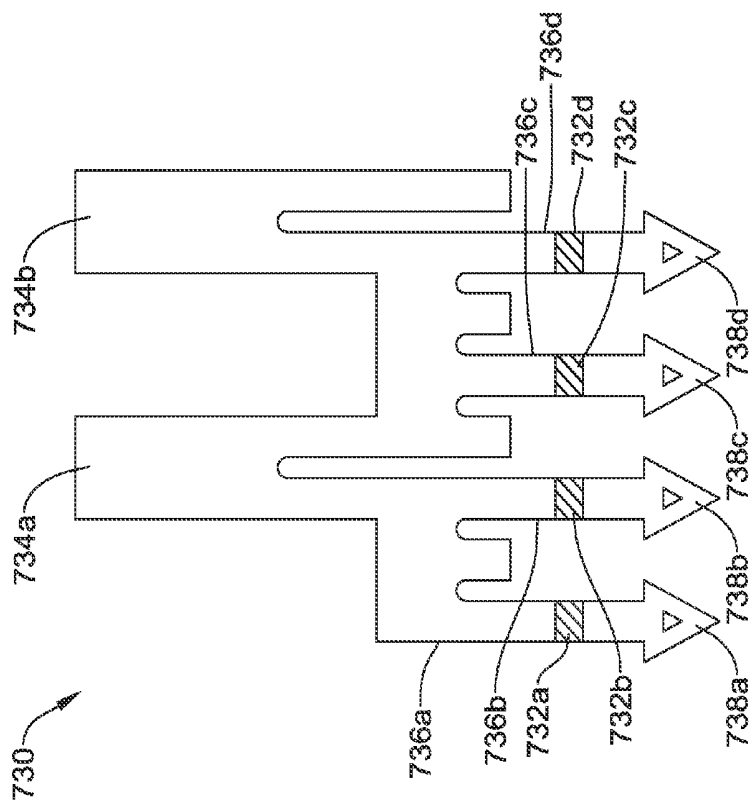

FIG. 18

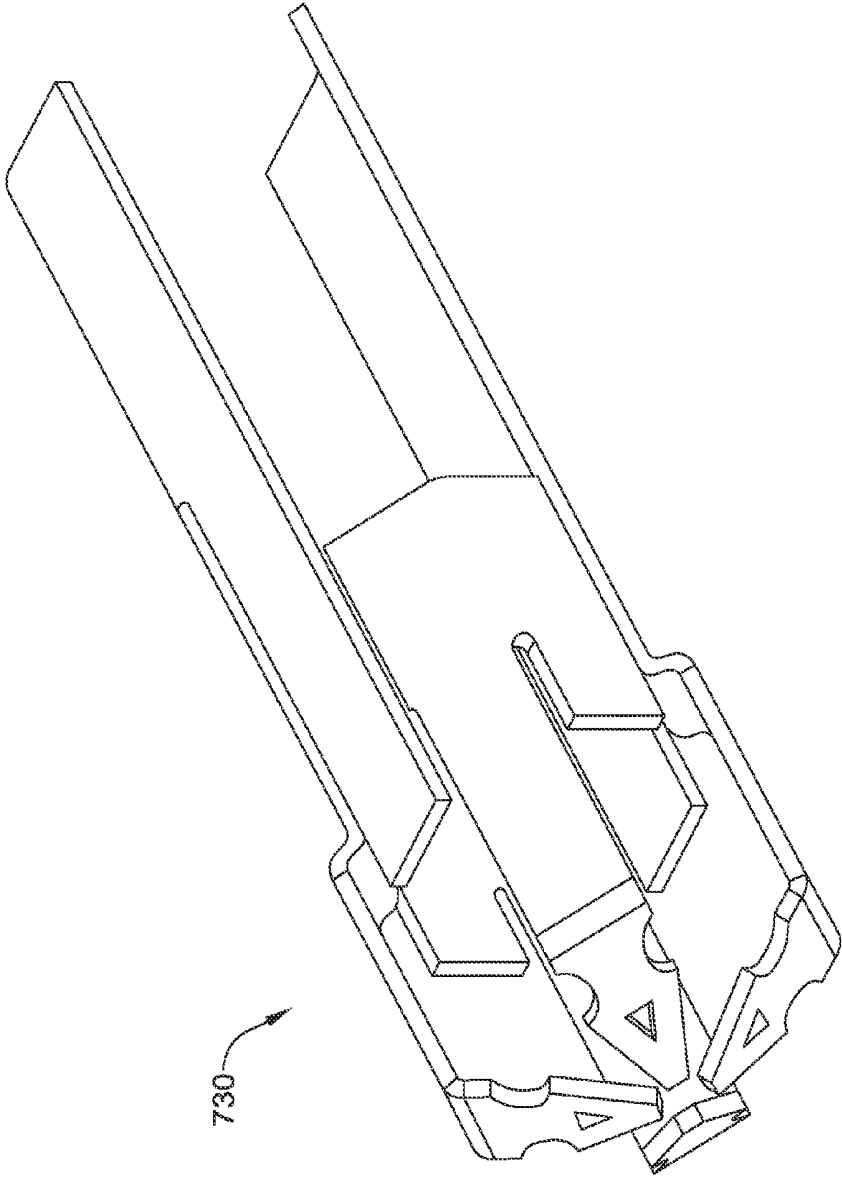

FIG. 19

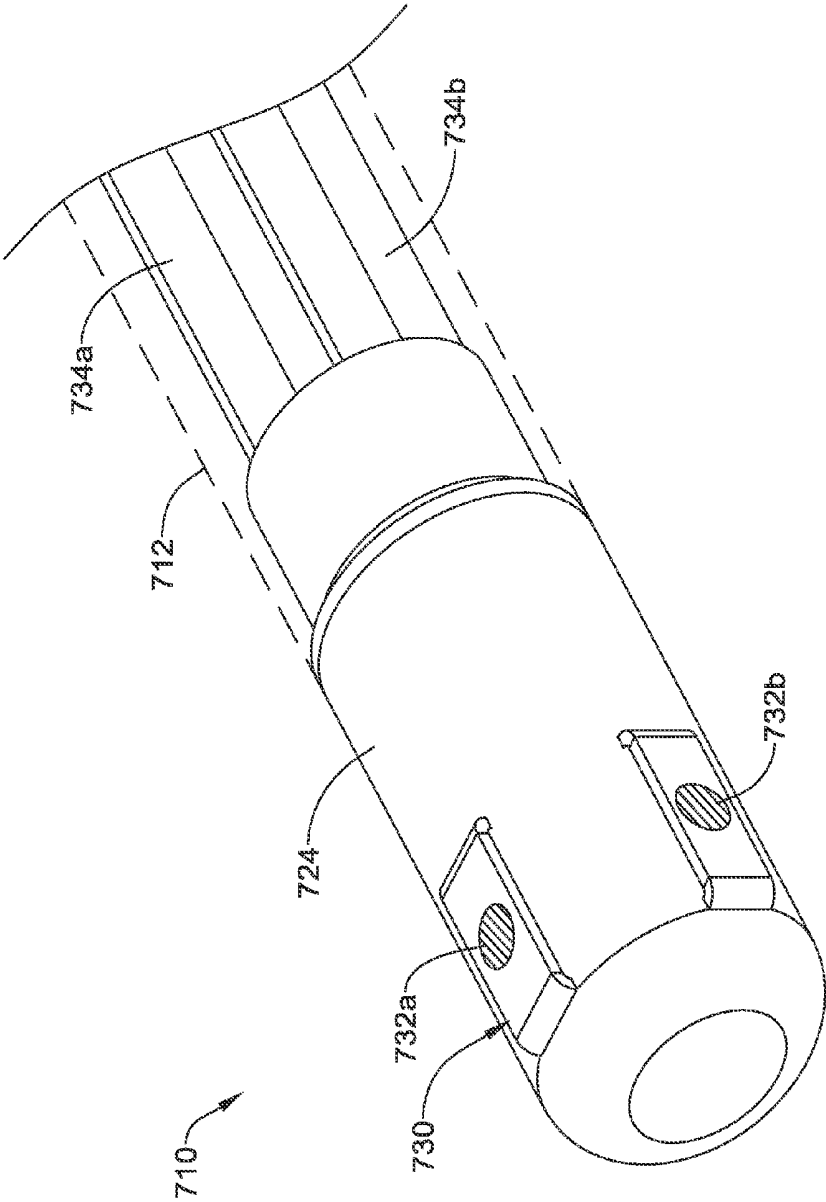

FIG. 20

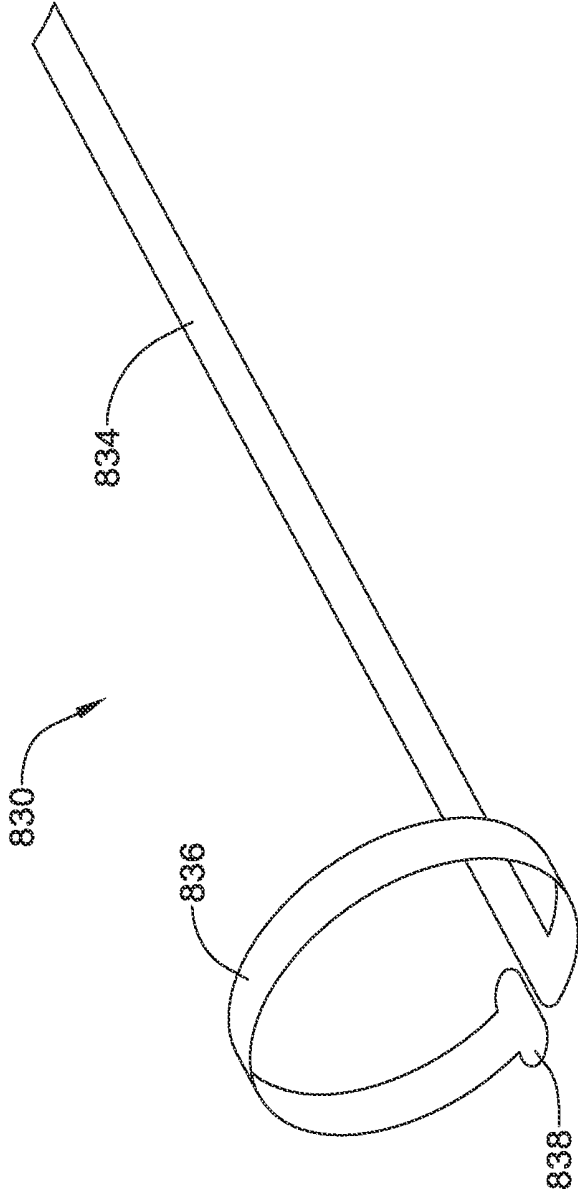

FIG. 21

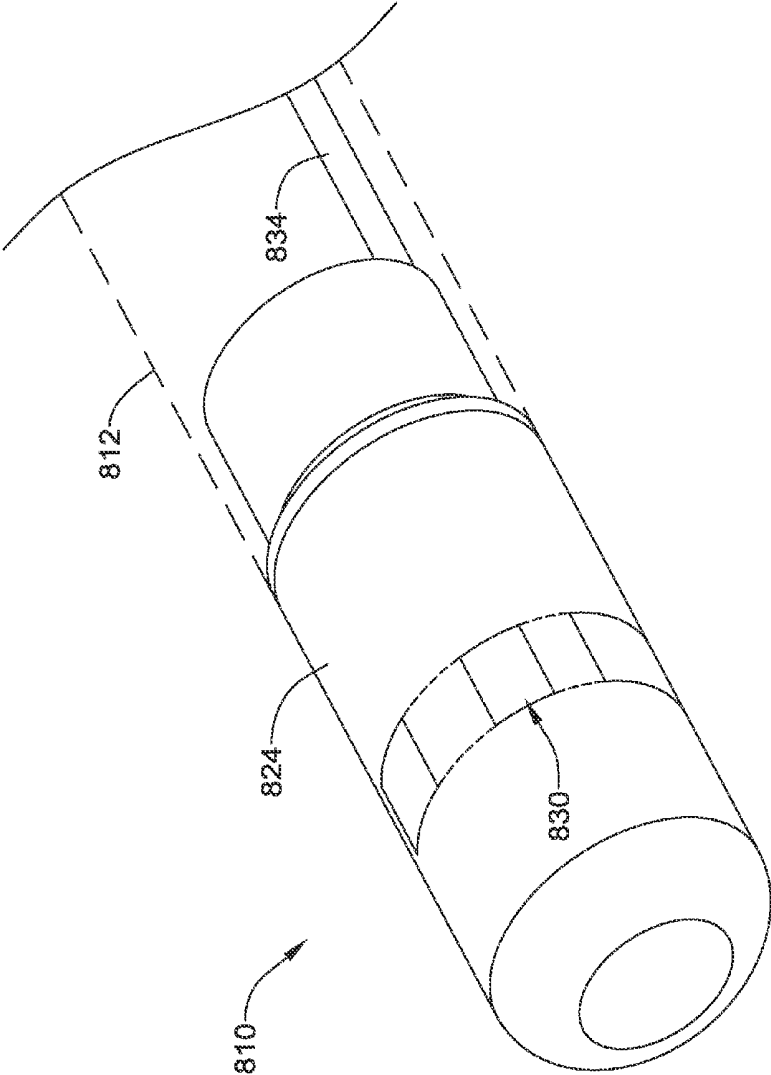

FIG. 22

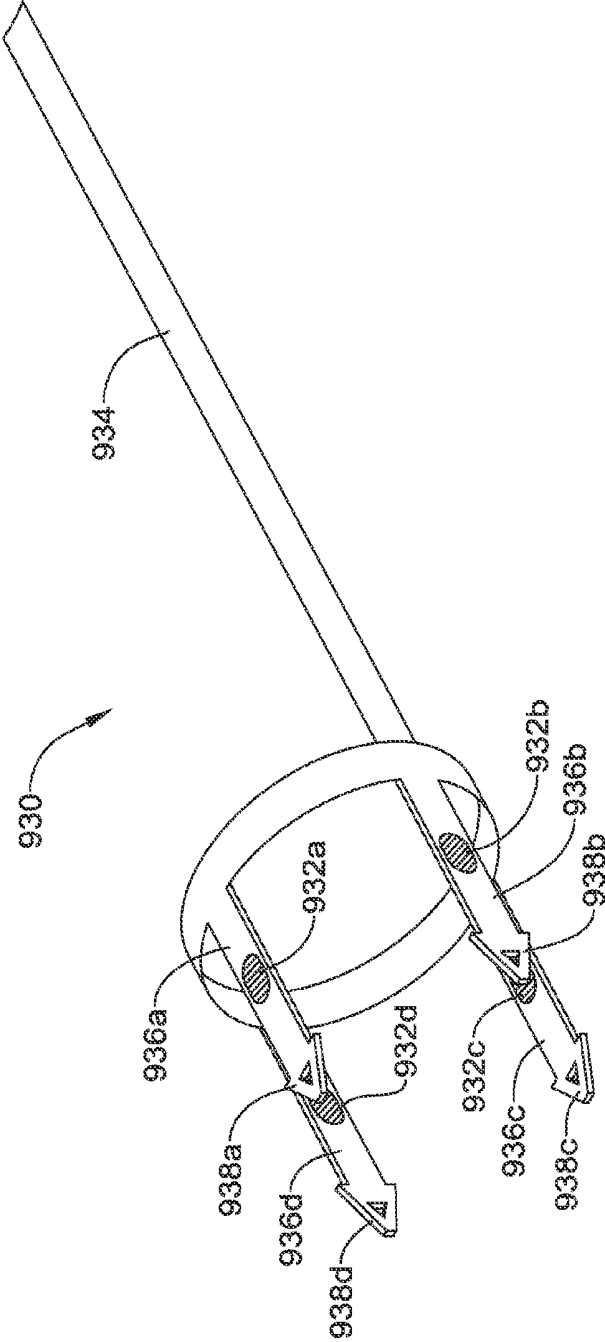

FIG. 23

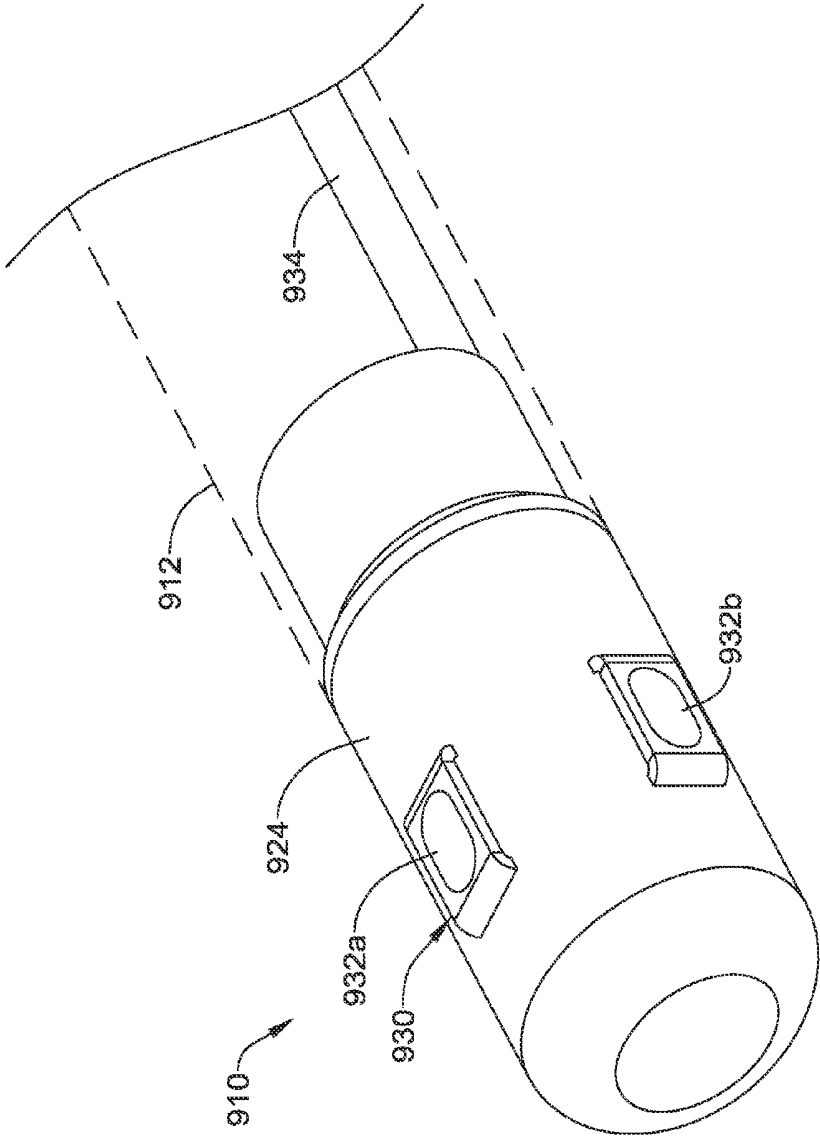

FIG. 24

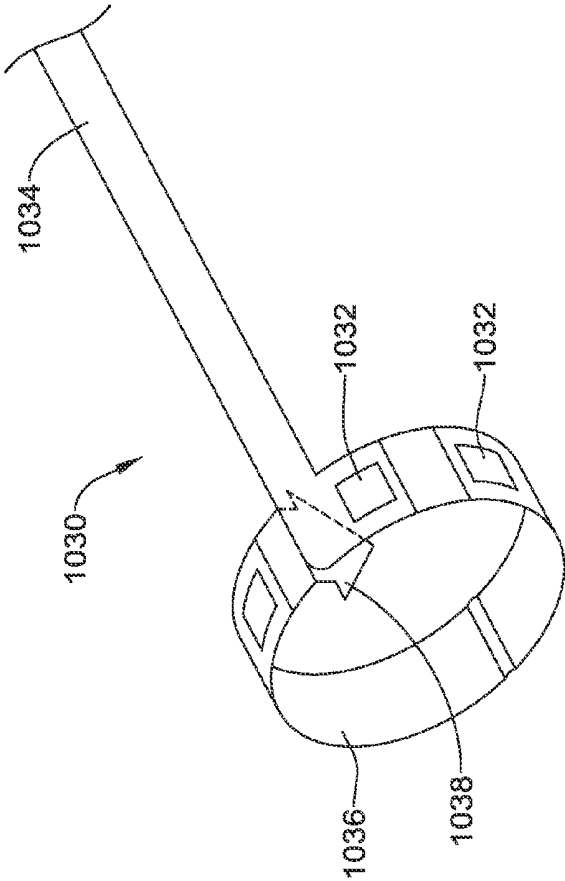

FIG. 25

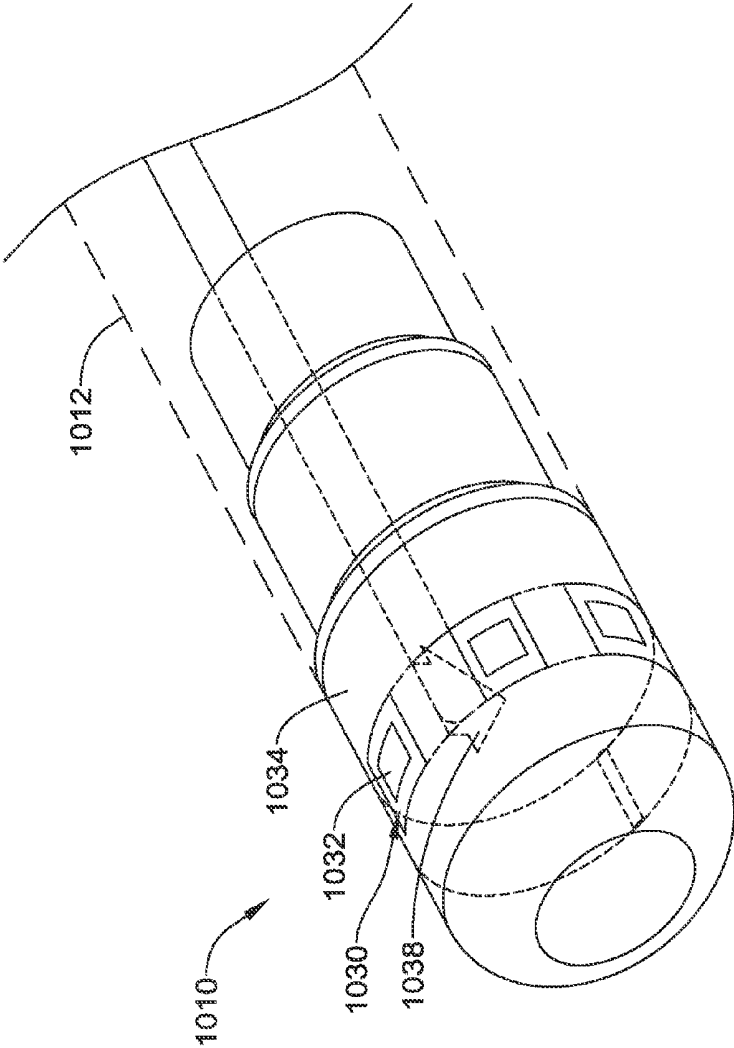

FIG. 26

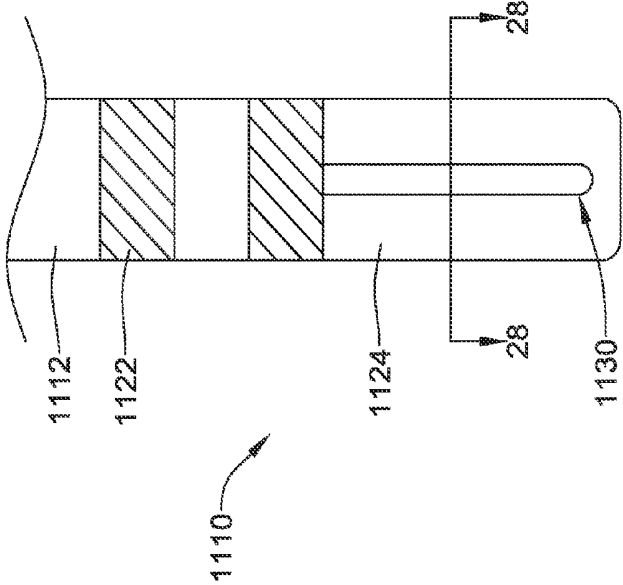

FIG. 27

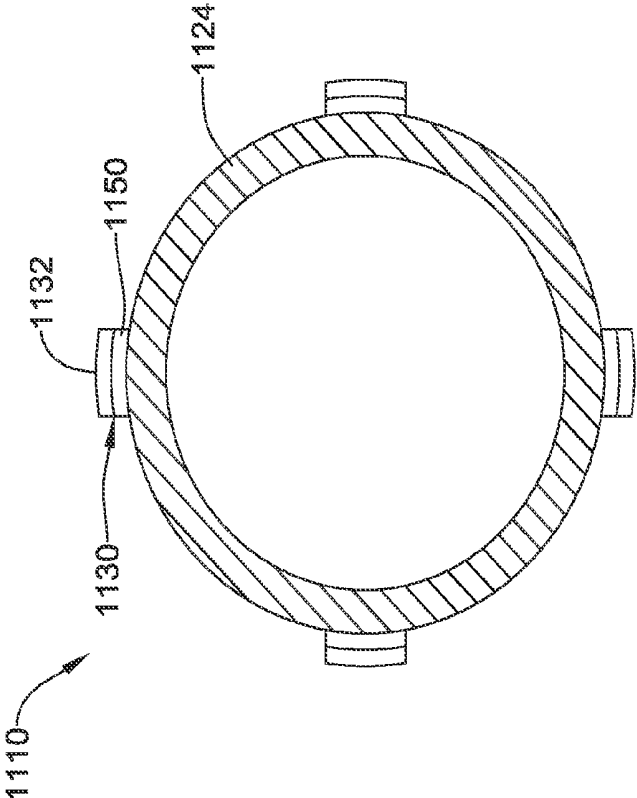

FIG. 28

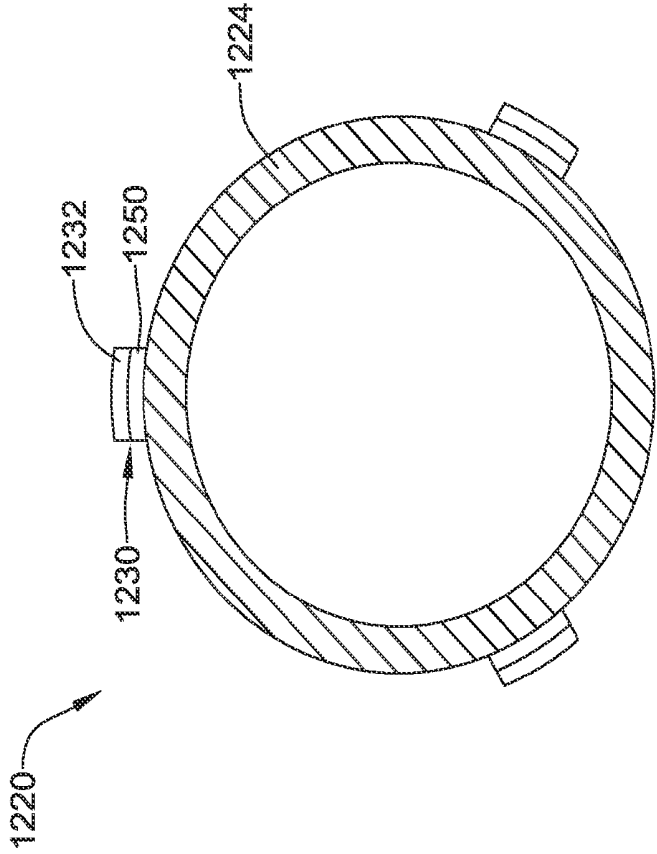

FIG. 29

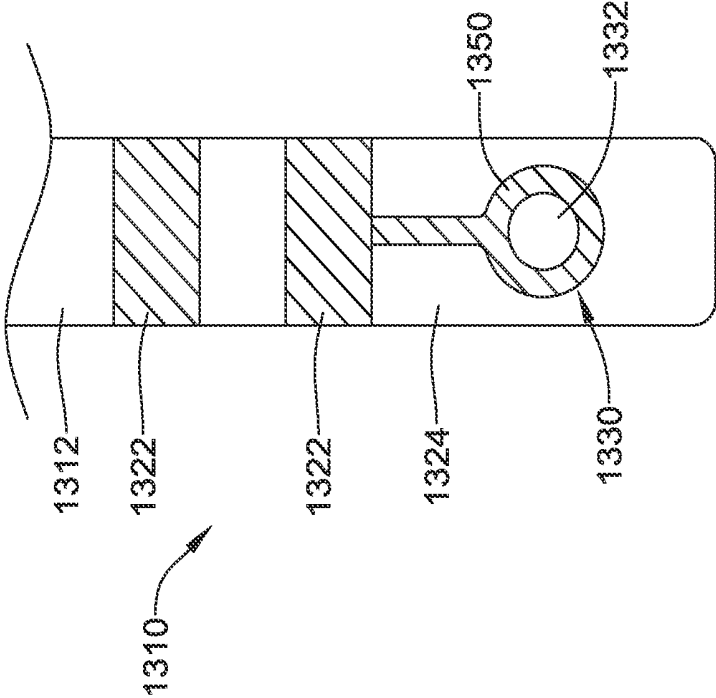

FIG. 30

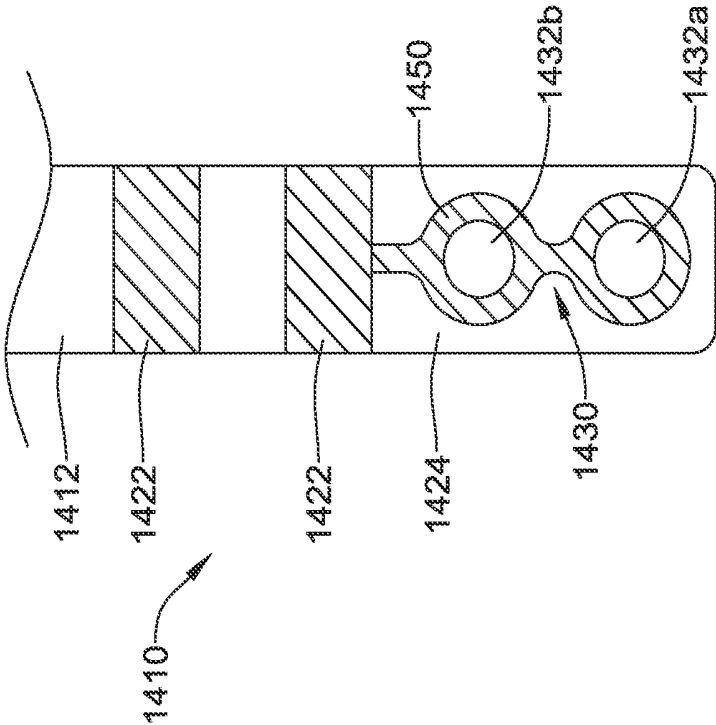

FIG. 31

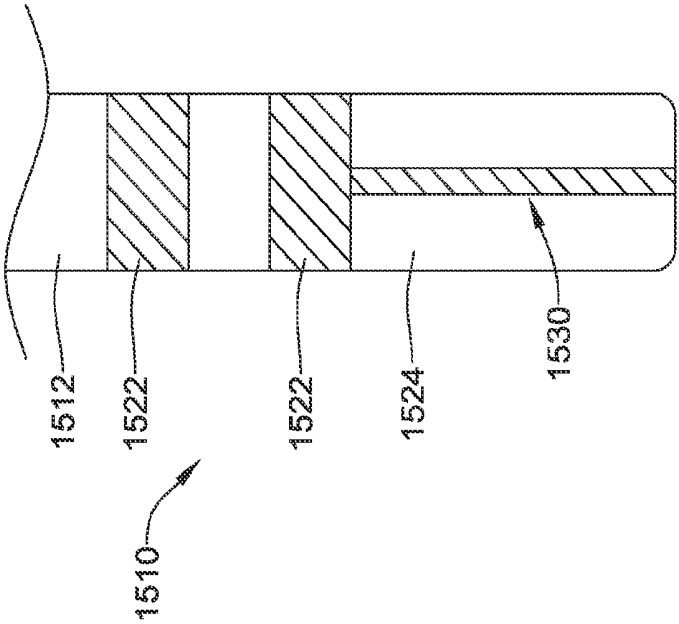

FIG. 32

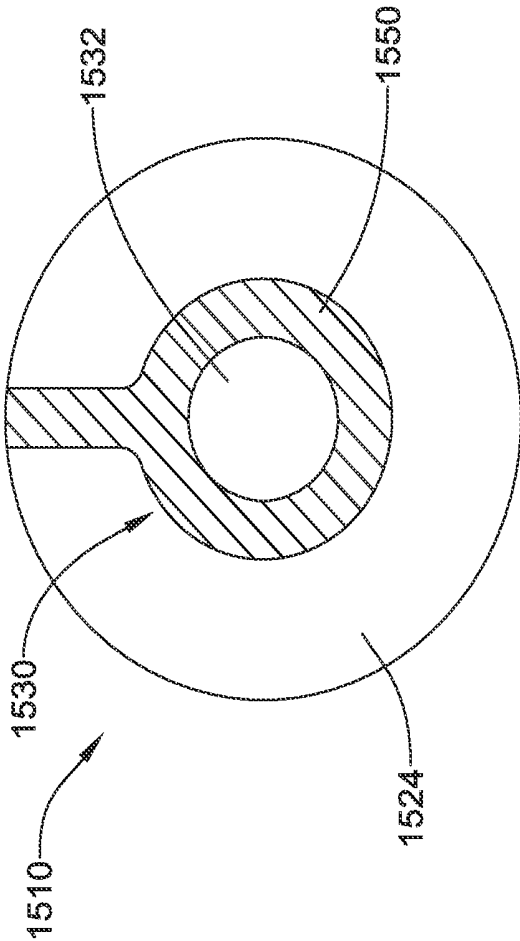

FIG. 33

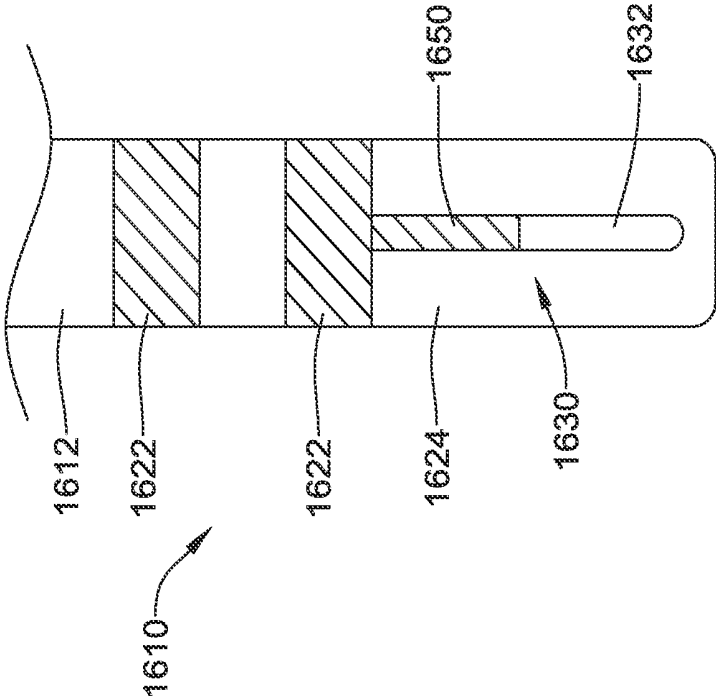

FIG. 34

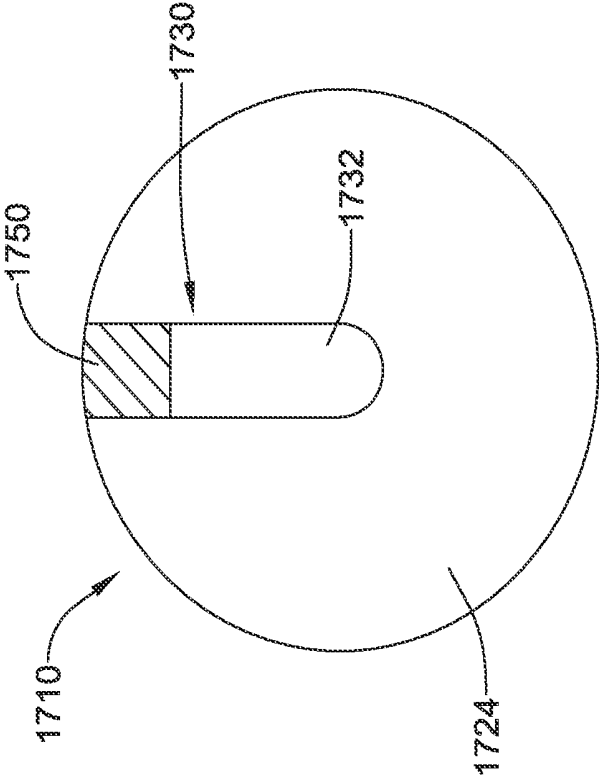

FIG. 35

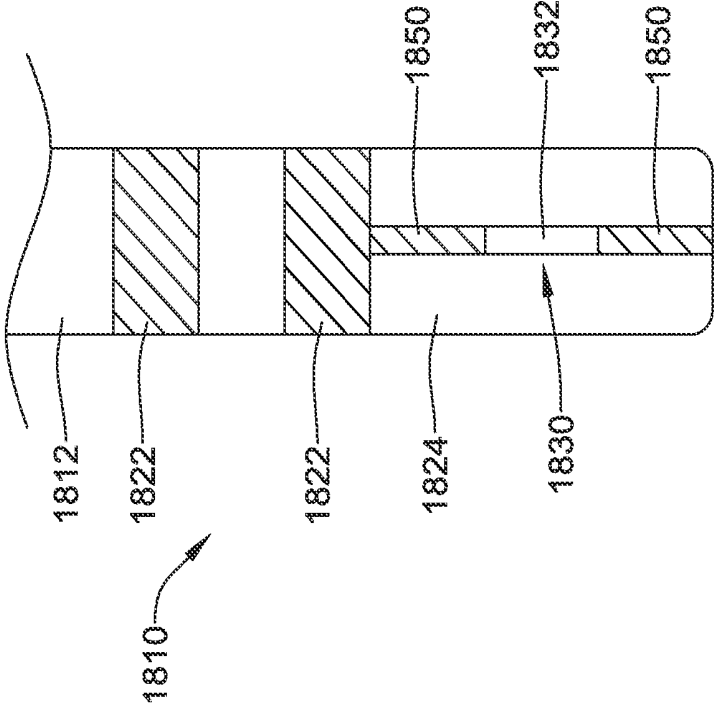

FIG. 36

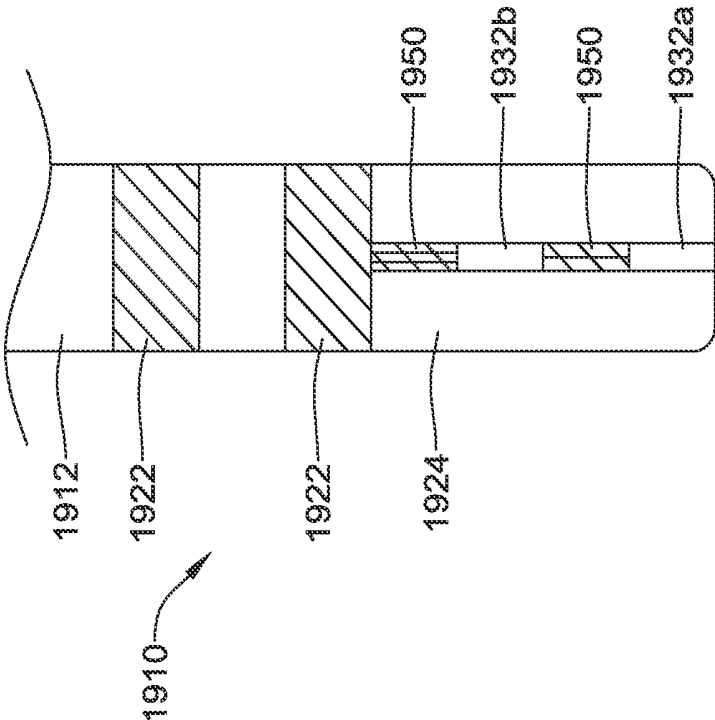

FIG. 37

**MEDICAL DEVICES WITH A FLEXIBLE
ELECTRODE ASSEMBLY COUPLED TO AN
ABLATION TIP**

CROSS-REFERENCE TO RELATED
APPLICATION

[0001] This application claims priority to Provisional Application No. 62/068,334, filed Oct. 24, 2014, which is herein incorporated by reference in its entirety.

TECHNICAL FIELD

[0002] The present disclosure pertains to medical devices, and methods for manufacturing medical devices. More particularly, the present disclosure pertains to for cardiac mapping and/or ablation.

BACKGROUND

[0003] A wide variety of intracorporeal medical devices have been developed for medical use, for example, intravascular use. Some of these devices include guidewires, catheters, and the like. These devices are manufactured by any one of a variety of different manufacturing methods and may be used according to any one of a variety of methods. Of the known medical devices and methods, each has certain advantages and disadvantages. There is an ongoing need to provide alternative medical devices as well as alternative methods for manufacturing and using medical devices.

SUMMARY

[0004] This disclosure provides design, material, manufacturing method, and use alternatives for medical devices. An example catheter may include a catheter for use in cardiac mapping and/or ablation. The catheter comprises:

[0005] an elongate catheter shaft having a distal ablation electrode region;

[0006] an electrode assembly coupled to the distal ablation electrode region; and

[0007] wherein the electrode assembly includes a flexible circuit having one or more electrodes disposed thereon.

[0008] Alternatively or additionally to any of the embodiments above, the distal ablation electrode region has an opening formed therein and wherein the electrode assembly extends through the opening.

[0009] Alternatively or additionally to any of the embodiments above, the electrode assembly includes a region that is disposed along a distal end of the distal ablation electrode region.

[0010] Alternatively or additionally to any of the embodiments above, the electrode assembly includes a plurality of arm regions and wherein each of the arm regions includes at least one electrode.

[0011] Alternatively or additionally to any of the embodiments above, the electrode assembly includes three or more arm regions.

[0012] Alternatively or additionally to any of the embodiments above, the electrode assembly includes four or more arm regions.

[0013] Alternatively or additionally to any of the embodiments above, the electrode assembly includes a mechanical locking end region that is capable of mechanically securing the electrode assembly to the distal ablation electrode region.

[0014] Alternatively or additionally to any of the embodiments above, the distal ablation electrode region has an opening formed therein and wherein the mechanical locking end region extends through the opening.

[0015] Alternatively or additionally to any of the embodiments above, the catheter shaft includes an inner channel, wherein the distal ablation electrode region includes a first opening and a second opening, and wherein the electrode assembly extends along the inner channel, through the first opening, along an outer surface of the distal ablation electrode region, and through the second opening.

[0016] Alternatively or additionally to any of the embodiments above, the electrode assembly is adhesively bonded to the distal ablation electrode region.

[0017] Alternatively or additionally to any of the embodiments above, the electrode assembly includes one or more electrode regions and one or more electrically insulated regions.

[0018] Alternatively or additionally to any of the embodiments above, the electrode assembly extends circumferentially around the distal ablation electrode region.

[0019] Alternatively or additionally to any of the embodiments above, the electrode assembly is designed to bow radially outward from the distal ablation electrode region.

[0020] Alternatively or additionally to any of the embodiments above, the distal ablation electrode region includes a platinum ablation tip electrode.

[0021] Methods for manufacturing a medical device are also disclosed. The methods may comprise:

[0022] inserting an electrode assembly into a channel formed within a distal ablation tip of a catheter;

[0023] wherein the electrode assembly includes a flexible circuit having one or more electrodes disposed thereon;

[0024] wherein the distal ablation tip includes a first opening and a second opening; and

[0025] extending the electrode assembly through the first opening, along an outer surface of the distal ablation tip, and through the second opening.

[0026] Another embodiment of a catheter for use in cardiac mapping and/or ablation may comprise:

[0027] an elongate catheter shaft having an inner channel and a distal end region;

[0028] a distal ablation tip capable of ablating tissue disposed at the distal end region;

[0029] an electrode assembly coupled to the distal ablation tip;

[0030] wherein the electrode assembly includes a flexible circuit having one or more electrodes disposed thereon;

[0031] wherein the distal ablation electrode region includes a first opening and a second opening;

[0032] wherein the electrode assembly extends along the inner channel, through the first opening, along an outer surface of the distal ablation tip, and through the second opening.

[0033] Alternatively or additionally to any of the embodiments above, the electrode assembly includes a region that is disposed along a distal end of the distal ablation tip.

[0034] Alternatively or additionally to any of the embodiments above, the electrode assembly includes a plurality of arm regions and wherein each of the arm regions includes at least one electrode.

[0035] Alternatively or additionally to any of the embodiments above, the electrode assembly includes a mechanical locking end region that is capable of mechanically securing the electrode assembly to the distal ablation tip.

[0036] Alternatively or additionally to any of the embodiments above, the mechanical locking end region extends through the first opening, the second opening, or both.

[0037] The above summary of some embodiments is not intended to describe each disclosed embodiment or every implementation of the present disclosure. The Figures, and Detailed Description, which follow, more particularly exemplify these embodiments.

[0038] While multiple embodiments are disclosed, still other embodiments of the present invention will become apparent to those skilled in the art from the following detailed description, which shows and describes illustrative embodiments of the invention. Accordingly, the drawings and detailed description are to be regarded as illustrative in nature and not restrictive.

BRIEF DESCRIPTION OF THE DRAWINGS

[0039] The disclosure may be more completely understood in consideration of the following detailed description in connection with the accompanying drawings, in which:

[0040] FIG. 1 is a plan view of an example cardiac mapping and/or ablation system;

[0041] FIG. 2 is a partially cutaway perspective view of a portion of an example cardiac mapping and/or ablation system;

[0042] FIG. 3 is a perspective view of an example electrode assembly;

[0043] FIGS. 4-6 illustrate an example method for securing an electrode assembly to a cardiac mapping and/or ablation system;

[0044] FIG. 7 is a side view of an example electrode assembly;

[0045] FIG. 8 is a partially cutaway perspective view of a portion of an example cardiac mapping and/or ablation system;

[0046] FIG. 9 is a side view of an example electrode assembly;

[0047] FIG. 10 is a partially cutaway perspective view of a portion of an example cardiac mapping and/or ablation system;

[0048] FIG. 11 is a side view of an example electrode assembly;

[0049] FIG. 12 is a partially cutaway perspective view of a portion of an example cardiac mapping and/or ablation system;

[0050] FIG. 13 is a side view of an example electrode assembly;

[0051] FIG. 14 is a partially cutaway perspective view of a portion of an example cardiac mapping and/or ablation system;

[0052] FIG. 15 is a side view of an example electrode assembly;

[0053] FIG. 16 is a perspective view of an example electrode assembly in a cylindrical configuration;

[0054] FIG. 17 is a side view of a portion of an example cardiac mapping and/or ablation system;

[0055] FIG. 18 is a side view of an example electrode assembly;

[0056] FIG. 19 is a perspective view of an example electrode assembly in a cylindrical configuration;

[0057] FIG. 20 is a side view of a portion of an example cardiac mapping and/or ablation system;

[0058] FIG. 21 is a perspective view of an example electrode assembly;

[0059] FIG. 22 is a partially cutaway perspective view of a portion of an example cardiac mapping and/or ablation system;

[0060] FIG. 23 is a perspective view of an example electrode assembly;

[0061] FIG. 24 is a partially cutaway perspective view of a portion of an example cardiac mapping and/or ablation system;

[0062] FIG. 25 is a perspective view of an example electrode assembly;

[0063] FIG. 26 is a partially cutaway perspective view of a portion of an example cardiac mapping and/or ablation system;

[0064] FIG. 27 is a side view of a portion of an example cardiac mapping and/or ablation system;

[0065] FIG. 28 is a cross-sectional view taken through line 28-28;

[0066] FIG. 29 is an alternative cross-sectional view taken through line 28-28;

[0067] FIG. 30 is a side view of a portion of an example cardiac mapping and/or ablation system;

[0068] FIG. 31 is a side view of a portion of an example cardiac mapping and/or ablation system;

[0069] FIG. 32 is a side view of a portion of an example cardiac mapping and/or ablation system;

[0070] FIG. 33 is an end view of the example cardiac mapping and/or ablation system shown in FIG. 32;

[0071] FIG. 34 is a side view of a portion of an example cardiac mapping and/or ablation system;

[0072] FIG. 35 is an end view of an example cardiac mapping and/or ablation system shown;

[0073] FIG. 36 is a side view of a portion of an example cardiac mapping and/or ablation system; and

[0074] FIG. 37 is a side view of a portion of an example cardiac mapping and/or ablation system.

[0075] While the disclosure is amenable to various modifications and alternative forms, specifics thereof have been shown by way of example in the drawings and will be described in detail. It should be understood, however, that the intention is not to limit the invention to the particular embodiments described. On the contrary, the intention is to cover all modifications, equivalents, and alternatives falling within the spirit and scope of the disclosure.

DETAILED DESCRIPTION

[0076] For the following defined terms, these definitions shall be applied, unless a different definition is given in the claims or elsewhere in this specification.

[0077] All numeric values are herein assumed to be modified by the term “about”, whether or not explicitly indicated. The term “about” generally refers to a range of numbers that one of skill in the art would consider equivalent to the recited value (e.g., having the same function or result). In many instances, the terms “about” may include numbers that are rounded to the nearest significant figure.

[0078] The recitation of numerical ranges by endpoints includes all numbers within that range (e.g. 1 to 5 includes 1, 1.5, 2, 2.75, 3, 3.80, 4, and 5).

[0079] As used in this specification and the appended claims, the singular forms “a”, “an”, and “the” include plural

referents unless the content clearly dictates otherwise. As used in this specification and the appended claims, the term “or” is generally employed in its sense including “and/or” unless the content clearly dictates otherwise.

[0080] It is noted that references in the specification to “an embodiment”, “some embodiments”, “other embodiments”, etc., indicate that the embodiment described may include one or more particular features, structures, and/or characteristics. However, such recitations do not necessarily mean that all embodiments include the particular features, structures, and/or characteristics. Additionally, when particular features, structures, and/or characteristics are described in connection with one embodiment, it should be understood that such features, structures, and/or characteristics may also be used in connection with other embodiments whether or not explicitly described unless clearly stated to the contrary.

[0081] The following detailed description should be read with reference to the drawings in which similar elements in different drawings are numbered the same. The drawings, which are not necessarily to scale, depict illustrative embodiments and are not intended to limit the scope of the invention.

[0082] FIG. 1 illustrates an example cardiac mapping and/or ablation system 10. As shown in FIG. 1, system 10 may include an elongated member or catheter shaft 12, an RF generator 14, and a processor 16 (e.g., a mapping processor, ablation processor, and/or other processor). Illustratively, shaft 12 may be operatively coupled to at least one or more (e.g., one or both) of RF generator 14 and processor 16. Alternatively, or in addition, a device, other than shaft 12, that may be utilized to apply ablation energy to and/or map a target area, may be operatively coupled to at least one or more of RF generator 14 and processor 16. RF generator 14 may be capable of delivering and/or may be configured to deliver ablation energy to shaft 12 in a controlled manner in order to ablate target area sites identified by processor 16. Although the processor 16 and RF generator 14 may be shown as discrete components, these components or features of components may be incorporated into a single device. System 10 may include any of one or more other features, as desired.

[0083] In at least some embodiments, shaft 12 may include a handle 18, which may have an actuator 20 (e.g., a control knob or other actuator). The handle 18 (e.g., a proximal handle) may be positioned at a proximal end of shaft 12, for example. Illustratively, shaft 12 may include a flexible body having a distal portion which may include the one or more electrodes. For example, the distal portion of shaft 12 may include one or more of a plurality of ring electrodes 22, a distal ablation tip electrode 24, and a plurality of micro-electrodes or micro-electrode assemblies 26 disposed or otherwise positioned within and/or electrically isolated from distal ablation tip electrode 24.

[0084] Shaft 12 may be steerable to facilitate navigating the vasculature of a patient or navigating other lumens. Illustratively, a distal portion 13 of shaft 12 may be deflected by manipulation of actuator 20 to effect steering shaft 12. In some instances, distal portion 13 of shaft 12 may be deflected to position distal ablation tip electrode 24 and/or micro-electrode assemblies 26 adjacent target tissue or to position the distal portion 13 of shaft 12 for another suitable purpose. Additionally, or alternatively, distal portion 13 of shaft 12 may have a pre-formed shape adapted to facilitate positioning distal ablation tip electrode 24 and/or micro-electrode assemblies 26 adjacent a target tissue. Illustratively, the preformed shape of distal portion 13 of shaft 12 may be a radiused shape

(e.g., a generally circular shape or a generally semi-circular shape) and/or may be oriented in a plane transverse to a general longitudinal direction of shaft 12. These are just examples.

[0085] In some instances, system 10 may be utilized in ablation procedures on a patient. Illustratively, shaft 12 may be configured to be introduced into or through vasculature of a patient and/or into or through any other lumen or cavity. In one example, shaft 12 may be inserted through the vasculature of the patient and into one or more chambers of the patient's heart (e.g., a target area). When in the patient's vasculature or heart, shaft 12 may be used to map and/or ablate myocardial tissue using the ring electrodes 22, micro-electrode assemblies 26, and/or distal ablation tip electrode 24. In some instances, distal ablation tip electrode 24 may be configured to apply ablation energy to myocardial tissue of the heart of a patient.

[0086] In some instances, micro-electrode assemblies 26 may be circumferentially distributed about a distal ablation tip electrode 24. In some instances, system 10 may not include distal ablation tip electrode 24 and, in such embodiments, micro-electrode assemblies 26 may be circumferentially distributed about shaft 12 (e.g., along a distal tip of shaft 12). In general, micro-electrode assemblies 26, as their name suggests, are relatively small in size (e.g., smaller than distal ablation tip electrode 24). Micro-electrode assemblies 26 may be capable of operating, or configured to operate, in unipolar or bipolar sensing modes. In some cases, micro-electrode assemblies 26 may define and/or at least partially form one or more bipolar microelectrode pairs. In an illustrative instance, shaft 12 may have three micro-electrode assemblies 26 distributed about the circumference of distal ablation tip electrode 24, such that the circumferentially spaced micro-electrodes may form respective bipolar microelectrode pairs. Each bipolar microelectrode pair may be capable of generating, or may be configured to generate, an output signal corresponding to a sensed electrical activity (e.g., an electrogram (EGM) reading) of the myocardial tissue proximate thereto. Additionally or alternatively to the circumferentially spaced micro-electrode assemblies 26, shaft 12 may include one or more forward facing micro-electrode assemblies 26 (not shown). The forward facing micro-electrode assemblies 26 may be generally centrally located within distal ablation tip electrode 24 and/or at an end of a tip of shaft 12.

[0087] In some examples, micro-electrode assemblies 26 may be operatively coupled to processor 16 and the generated output signals from micro-electrode assemblies 26 may be sent to the processor 16 of ablation system 10 for processing in one or more manners discussed herein and/or for processing in other manners. Illustratively, an EGM reading or signal of an output signal from a bipolar microelectrode pair may at least partially form the basis of a contact assessment, ablation area assessment (e.g., tissue viability assessment), and/or an ablation progress assessment (e.g., a lesion formation/maturation analysis), as discussed below.

[0088] Distal ablation tip electrode 24 may be a suitable length and may have a suitable number of micro-electrode assemblies 26 positioned therein and spaced circumferentially and/or longitudinally about distal ablation tip electrode 24. In some instances, distal ablation tip electrode 24 may have a length of between one (1) mm and twenty (20) mm, three (3) mm and seventeen (17) mm, or six (6) mm and fourteen (14) mm. In one illustrative example, distal ablation tip electrode 24 may have an axial length of about eight (8)

mm. Distal ablation tip electrode **24** may be formed from other otherwise include platinum and/or other suitable materials. These are just examples.

[0089] Processor **16** may be capable of processing or may be configured to process the electrical signals of the output signals from micro-electrode assemblies **26** and/or ring electrodes **22**. Based, at least in part, on the processed output signals from micro-electrode assemblies **26** and/or ring electrodes **22**, processor **16** may generate an output to a display (not shown) for use by a physician or other user. In instances where an output is generated to a display and/or other instances, processor **16** may be operatively coupled to or otherwise in communication with the display. Illustratively, the display may include various static and/or dynamic information related to the use of system **10**. In one example, the display may include one or more of an image of the target area, an image of shaft **12**, and information related to EGMs, which may be analyzed by the user and/or by a processor of system **10** to determine the existence and/or location of arrhythmia substrates within the heart, to determine the location of shaft **12** within the heart, and/or to make other determinations relating to use of shaft **12** and/or other elongated members.

[0090] System **10** may include an indicator in communication with processor **16**. The indicator may be capable of providing an indication related to a feature of the output signals received from one or more of the electrodes of shaft **12**. In one example of an indicator, an indication to the clinician about a characteristic of shaft **12** and/or the myocardial tissue interacted with and/or being mapped may be provided on the display. In some cases, the indicator may provide a visual and/or audible indication to provide information concerning the characteristic of shaft **12** and/or the myocardial tissue interacted with and/or being mapped.

[0091] FIG. 2 illustrates another example system **110** that may be similar in form and function to other systems disclosed herein. System **110** may include catheter shaft **112**. Distal ablation tip electrode **124** may be disposed at the distal end of catheter shaft **112**. Distal ablation tip electrode **124** may include one or more irrigation ports. For example, distal ablation tip electrode **124** may include one or more circumferential irrigation ports **126**. In some of these and in other instances, distal ablation tip electrode **124** may also include a distal irrigation port **128**. In uses where irrigation is not desired/needed, ports **126/128** may be omitted or sealed, for example with an epoxy.

[0092] In some instances, one or more micro-electrode assemblies (e.g., similar to micro-electrode assemblies **26**) may be disposed along distal ablation tip electrode **124**. In some of these and in other embodiments, an electrode assembly **130** may be coupled to distal ablation tip electrode **124**. Electrode assembly **130** may include one or more electrodes or electrode regions **132**. Electrodes **132** may include monopolar electrodes, one or more pairs of bipolar electrodes, or combinations thereof. Electrodes **132** may also take the form of sensors such as impedance and/or contact sensors. A proximal connector **134** may be disposed along (e.g., within) catheter shaft **112**. Proximal connector **134** may be used to connect electrode assembly **130** with a suitable processor/generator.

[0093] The use of electrode assembly **130** may be desirable for a number of reasons. For example, electrode assembly **130** may allow for electrodes **132** to be disposed at the front face or distal end of distal ablation tip **124**. This may allow elec-

trodes **132** to be used to sense contact between distal ablation tip **124** and a target tissue. In addition, because it may have a relatively small, compact shape, the use of electrode assembly **130** may free up additional space along and/or within distal ablation tip **124** for other useful structures such as micro-electrodes, force sensors, contact sensors, magnetic sensors, or the like. Moreover, electrode assembly **130** may be wrapped or otherwise disposed along distal ablation tip **124** in a manner that reduces protruding edges that could catch on tissue, other medical devices, etc. Furthermore, by weaving electrode assembly **130** through openings in distal ablation tip **124**, RF edge effects may be reduced or minimized.

[0094] Electrode assembly **130** may take the form of a flexible circuit. For example, electrode assembly **130** may include a substrate with one or more electrodes (e.g., electrodes **132**) disposed thereon. The substrate may include a polymeric material (e.g., such as polyimide or other suitable materials including those disclosed herein). Electrode assembly **130** may include a coating such as a parylene coating or other suitable biocompatible coating. Electrodes **132** may be sputtered onto the substrate with iridium oxide. In some of these and in other embodiments, electrodes **132** may be copper or gold electrodes (or electrodes formed of other suitable materials) disposed along the substrate. In some instances, a temperature or other sensor may be disposed along the substrate. In addition, a magnetic sensing coil, piezoelectric film, MEMS force sensor, or the like may be coupled to assembly **130**. Some example flexible circuits that may be suitable for use as electrode assembly **130** may include or resemble those disclosed in U.S. Patent Application Pub. No. US 2013/0165926, the entire disclosure of which is herein incorporated by reference. The use of a flex circuit may be desirable by allowing for batch processing at relatively high volumes so that manufacturability of system **110** may be increased.

[0095] In some instances, electrode assembly **130** may include an inner insulating layer contacts distal ablation tip **124** and electrically insulates electrode assembly **130** from distal ablation tip **124**. Electrodes **132** may be disposed on the insulating layer. Alternatively, electrodes **132** may take the form of a conductive layer or trace disposed along the insulating layer. The conductive layer may extend along essentially the entire length of the insulating layer or along one or more discrete sections thereof. Numerous configurations are contemplated.

[0096] FIG. 3 is a perspective view of electrode assembly **130**. Here it can be seen that electrode assembly **130** may include a plurality of arms including arms **136a/136b/136c/136d** each having one or more electrodes **132a/132b/132c/132d**. Each of arms **136a/136b/136c/136d** may include a mechanical interconnecting member **138a/138b/138c/138d**. Mechanical interconnecting members **138a/138b/138c/138d** may be utilized to secure electrode assembly **130** to system **110** (and/or distal ablation tip **124**). In this example, mechanical interconnecting members **138a/138b/138c/138d** take the form of arrow-shaped projections with a tapered edge. Such a shape may allow mechanical interconnecting members **138a/138b/138c/138d** to be passed through an opening and, by interference, being sufficiently captured within the opening. The precise shape of mechanical interconnecting members **138a/138b/138c/138d** may vary and is not intended to be limited to just being arrow-shaped. Mechanical interconnecting members **138a/138b/138c/138d** may have a variety of shapes including rounded shapes, geometric shapes, shapes

with relief cutouts (e.g., a “split arrow” shape), shapes with flanges and/or projections, shapes that are deformable or reshapable into two or more shapes, or the like. These are just examples. Other shapes are contemplated.

[0097] FIGS. 4-6 illustrate an example method for manufacturing and/or assembling system 110. For example, in FIG. 4 it can be seen that electrode assembly 130 may be disposed along an interior of distal ablation tip 124. Arms 136a/136b/136c/136d may be oriented so that mechanical interconnecting member 138a/138b/138c/138d extend through distal irrigation port 128. Arms 136a/136b/136c/136d may be manipulated so that mechanical interconnecting member 138a/138b/138c/138d are folded proximally toward openings 140a/140b as shown in FIG. 5. Openings 140a/140b may be cuts or slots formed in a suitable manner (e.g., laser cutting with chamfer to reduce/minimize abrasion with assembly 130). It can be appreciated that in the views of FIGS. 4-6 only two openings 140a/140b are shown. However, in practice a suitable number of openings may be utilized. For example, four openings may be utilized when electrode assembly 130 includes four arms. Mechanical interconnecting member 138a/138b/138c/138d may be extended into openings 140a/140b (and similar openings not shown in this view) as shown in FIG. 6. This may secure electrode assembly 130 to system 110 (and/or to distal ablation tip 124).

[0098] Proximal connector 134 may be coupled to a suitable processor/generator using flying leads, ribbonized cable, or by simply extending proximal connector 134 to the processor/generator. When connecting proximal connector 134 to another suitable device or wire, terminals may be disposed along proximal connector 134. The terminals may be formed by wire bonding, hot bar soldering, anisotropic conductive films, soldering, or the like.

[0099] FIG. 7 illustrates another example electrode assembly 230 that may be similar in form and function to other assemblies disclosed herein and may be used, as appropriate, with the systems disclosed herein. Assembly 230 may include arms 236a/236b/236c/236d. Each of arms 236a/236b/236c/236d may include mechanical interconnecting member 138a/138b/138c/138d. In this example, two electrodes are defined along each of arms 236a/236b/236c/236d. For example, arm 236a may include electrodes 232a/232a', arm 236b may include electrodes 232b/232b', arm 236c may include electrodes 232c/232c', and arm 236d may include electrodes 232d/232d'.

[0100] FIG. 8 illustrates system 210. System 210 includes catheter shaft 212. Proximal connector 234 may be disposed along shaft 212 and may be coupled to electrode assembly 230. Electrode assembly 230 may be assembled onto distal ablation tip 224 in a manner similar to what is disclosed herein. For example, arms 236a/236b/236c/236d may be passed through port 228 and woven in and out of a pair of openings along distal ablation tip 224 so that electrodes 232a/232a'/232b/232b'/232c/232c'/232d/232d' are disposed along tip 224. Alternatively, each of arms 236a/236b/236c/236d may be passed through port 228, along the outer surface of distal ablation tip 224, and then through a single opening along distal ablation tip 224. In at least some instances, distal ablation tip 224 takes the form of a distal ablation tip electrode 224.

[0101] FIG. 9 illustrates another example electrode assembly 330 that may be similar in form and function to other assemblies disclosed herein and may be used, as appropriate, with the systems disclosed herein. In this embodiment, elec-

trode assembly 330 may include three arms. For example, assembly 330 may include arms 336b/336c and a third arm/connector 334. Each of arms 336b/336c may include mechanical interconnecting member 338b/338c. Each of arms 336b/336c may include electrodes 332b/332c. Connector 334 may also include electrode 332a.

[0102] FIG. 10 illustrates system 310. System 310 includes catheter shaft 312. Electrode assembly 330 may be assembled onto distal ablation tip 324 in a manner similar to what is disclosed herein. For example, each of arms 336b/236c and connector 334 may be passed through port 328 and passed through an opening along distal ablation tip 324 so that electrodes 332a/332b/332c are disposed along tip 324. Connector 334 may continue along an inner surface (or an outer surface) of shaft 312 to a location where it may be coupled to a suitable processor/generator. In at least some instances, distal ablation tip 324 takes the form of a distal ablation tip electrode 324.

[0103] FIG. 11 illustrates another example electrode assembly 430 that may be similar in form and function to other assemblies disclosed herein and may be used, as appropriate, with the systems disclosed herein. Assembly 430 may include a plurality of electrodes 432. Assembly 430 may also include an opening 442 and proximal connector 434.

[0104] FIG. 12 illustrates system 410. System 410 includes catheter shaft 412. Electrode assembly 430 may be assembled onto distal ablation tip 424 in a manner similar to what is disclosed herein. For example, electrode assembly 430 may take the form of a strip that is designed to extend circumferentially about distal ablation tip 424. Proximal connector 434 may extend through opening 442 and then proximally along shaft 412. This may include extending proximal connector 434 along the outer surface of shaft 412, along the inner surface of shaft 412, or both. In at least some instances, distal ablation tip 424 takes the form of a distal ablation tip electrode 424.

[0105] FIG. 13 illustrates another example electrode assembly 530 that may be similar in form and function to other assemblies disclosed herein and may be used, as appropriate, with the systems disclosed herein. Assembly 530 may include a plurality of electrodes 532. Assembly 530 may also include a plurality of mechanical interconnecting members 538. In this example, a pair of opposing mechanical interconnecting members 538 are positioned on opposite sides of each electrode 532. Assembly 530 may also include proximal connector 534.

[0106] FIG. 14 illustrates system 510. System 510 includes catheter shaft 512. Electrode assembly 530 may be assembled onto distal ablation tip 524 in a manner similar to what is disclosed herein. For example, electrode assembly 530 may be disposed about distal ablation tip 524. Mechanical interconnecting members 538 may extend through openings in distal ablation tip 524 to secure electrode assembly 530 to system 510 (and/or distal ablation tip 524). In at least some instances, distal ablation tip 524 takes the form of a distal ablation tip electrode 524.

[0107] FIG. 15 illustrates another example electrode assembly 630 that may be similar in form and function to other assemblies disclosed herein and may be used, as appropriate, with the systems disclosed herein. Assembly 630 may include arms 636a/636b/636c/636d and proximal connector 634. Each of arms 636a/636b/636c/636d may include one or more electrodes such as electrodes 632a/632b/632c/632d. Assembly 630 may be rolled into a cylindrical configuration as shown in FIG. 16.

[0108] FIG. 17 illustrates system 610. System 610 includes catheter shaft 612. Electrode assembly 630 may be assembled along distal ablation tip 624 in a manner similar to what is disclosed herein. For example, electrode assembly 630 may be disposed within distal ablation tip 624. When assembled, arms 636a/636b/636c/636d extend through openings in distal ablation tip 624 and bow radially outward. This may be due to the application of a compressive force on electrode assembly 630 during the assembly process. Alternatively, an elastomeric gasket may be disposed within electrode assembly 630 in order to bias arms 636a/636b/636c/636d radially outward and/or seal the openings along distal ablation tip 624. The use of a gasket may allow the openings in distal ablation tip 624 to be sealed without the use of an adhesive. In addition, the use of a gasket may also allow for additional structures to be disposed along the interior of distal ablation tip 624. In some instances, the proximal and/or distal ends of assembly 630 may be secured to the inner surface of distal ablation tip 624. Although not expressly shown, system 610 may include one or more irrigation ports, for example along distal ablation tip 624. In at least some instances, distal ablation tip 624 takes the form of a distal ablation tip electrode 624.

[0109] The use of electrode assembly 630 may be desirable for a number of reasons. For example, using electrode assembly 630 may allow for assembly of system 610 while reducing/minimizing the possibility of damaging iridium oxide sputtered electrodes and/or to the parylene coating (e.g., when electrode assembly 630 includes such structures). The length of electrode assembly 630 exposed along the outer surface of system 610 may also be reduced, which may reduce the likelihood of electrode assembly 630 catching during a procedure and also may reduce the amount of surface area along distal ablation tip 624 that may be covered.

[0110] While FIGS. 14-16 illustrate arms 636a/636b/636c/636d oriented in an axial direction, electrode assembly 630 may also be arranged so that arms 636a/636b/636c/636d extend circumferentially or otherwise in a direction that is substantially transverse to the longitudinal axis of electrode assembly 630.

[0111] FIG. 18 illustrates another example electrode assembly 730 that may be similar in form and function to other assemblies disclosed herein and may be used, as appropriate, with the systems disclosed herein. Assembly 730 may include arms 736a/736b/736c/736d. Each of arms 736a/736b/736c/736d may include one or more electrodes such as electrodes 732a/732b/732c/732d and mechanical interconnecting members 738a/738b/738c/738d. Assembly 730 may also include a pair of proximal connectors 734a/734b. Assembly 730 may be formed into a generally cylindrical configuration as shown in FIG. 19.

[0112] FIG. 20 illustrates system 710. System 710 includes catheter shaft 712. Electrode assembly 730 may be assembled along distal ablation tip 724 in a manner similar to what is disclosed herein. For example, mechanical interconnecting members 738a/738b/738c/738d may extend through openings in distal ablation tip 724 to secure assembly 730 to system 710 (and/or to distal ablation tip 724). In at least some instances, distal ablation tip 724 takes the form of a distal ablation tip electrode 724.

[0113] FIG. 21 illustrates another example electrode assembly 830 that may be similar in form and function to other assemblies disclosed herein and may be used, as appropriate, with the systems disclosed herein. Assembly 830 may include arm 836, mechanical interconnecting member 838,

and proximal connector 834. FIG. 22 illustrates system 810. System 810 includes catheter shaft 812. Electrode assembly 830 may be assembled along distal ablation tip 824 in a manner similar to what is disclosed herein. For example, electrode assembly 830 may be wrapped circumferentially about distal ablation tip 824. Alternatively, electrode assembly 830 may be woven in and out of openings formed in distal ablation tip 824. In at least some instances, distal ablation tip 824 takes the form of a distal ablation tip electrode 824.

[0114] FIG. 23 illustrates another example electrode assembly 930 that may be similar in form and function to other assemblies disclosed herein and may be used, as appropriate, with the systems disclosed herein. Assembly 930 may include arms 936a/936b/936c/936d. Each of arms 936a/936b/936c/936d may include one or more electrodes such as electrodes 932a/932b/932c/932d and mechanical interconnecting members 938a/938b/938c/938d. Assembly 930 may also include proximal connector 934.

[0115] FIG. 24 illustrates system 910. System 910 includes catheter shaft 912. Electrode assembly 930 may be assembled along distal ablation tip 924 in a manner similar to what is disclosed herein. For example, mechanical interconnecting members 938a/938b/938c/938d may extend through openings in distal ablation tip 924 to secure assembly 930 to system 910 (and/or to distal ablation tip 924). In at least some instances, distal ablation tip 924 takes the form of a distal ablation tip electrode 924.

[0116] FIG. 25 illustrates another example electrode assembly 1030 that may be similar in form and function to other assemblies disclosed herein and may be used, as appropriate, with the systems disclosed herein. Assembly 1030 may include arm 1036 arranged in a cylindrical orientation. A plurality of electrodes 1032 may be disposed along arm 1036. Mechanical interconnecting member 1038 may be disposed on an end region of arm 1036. Assembly 1030 may also include proximal connector 1034.

[0117] FIG. 26 illustrates system 1010. System 1010 includes catheter shaft 1012. Electrode assembly 1030 may be assembled along distal ablation tip 1024 in a manner similar to what is disclosed herein. For example, mechanical interconnecting member 1038 may extend through openings in distal ablation tip 1024 to secure assembly 1030 to system 1010 (and/or to distal ablation tip 1024). In at least some instances, distal ablation tip 1024 takes the form of a distal ablation tip electrode 1024.

[0118] FIG. 27 is a side view of another example system 1110 that may be similar in form and function to other systems disclosed herein. System 1110 includes shaft 1112. One or more ring electrodes 1122 may be disposed along shaft 1112. Distal ablation tip 1124 may be disposed at the distal end of shaft 1112. Electrode assembly 1130 may be disposed along distal ablation tip 1124. For example, electrode assembly 1130 may be attached to distal ablation tip 1124 using an adhesive or other suitable attachment mechanism. In some embodiments, a single electrode assembly 1130 may be disposed along distal ablation tip 1124. In other embodiments, a plurality of electrode assemblies 1130 (e.g., 2-8 or more) may be disposed along distal ablation tip 1124. In at least some instances, distal ablation tip 1124 takes the form of a distal ablation tip electrode 1124. Each electrode assembly 1130 may be formed from a dielectric material disposed along distal ablation tip 1124 with a strip of electrode material (e.g., 300 series stainless steel, gold, platinum, copper, etc.) disposed along the dielectric material. Electrode assembly 1130

may have a width of about 0.01-0.04 inches (e.g., about 0.025 inches) and a length of about 1-5 millimeters (e.g., 3 mm or about 0.118 inches). These are just examples.

[0119] FIG. 28 is a cross-sectional view of a portion of system 1110. Here it can be seen that electrode assembly 1130 may include an inner insulating layer 1150 and an outer conductive layer or electrode regions 1132. In some of these and in other embodiments, electrode assembly 1130 may include a flexible circuit as disclosed herein.

[0120] While FIG. 28 shows that four electrode assemblies 1130 may be disposed about system 1110, this is not intended to be limiting. For example, FIG. 29 illustrates system 1220 that includes three electrode assemblies 1230 are disposed along distal ablation tip 1224. In at least some instances, distal ablation tip 1224 takes the form of a distal ablation tip electrode 1224. Similarly to electrode assemblies 1130, electrode assemblies 1230 may include inner insulating layer 1250 and outer conductive layer or electrode region 1232.

[0121] FIG. 30 is a side view of another example system 1310 that may be similar in form and function to other systems disclosed herein. System 1310 includes shaft 1312. One or more ring electrodes 1322 may be disposed along shaft 1312. Distal ablation tip 1324 may be disposed at the distal end of shaft 1312. Electrode assembly 1330 may be disposed along distal ablation tip 1324. Electrode assembly 1330 may include insulating layer 1350 and electrode region 1332. In this example, electrode region 1332 may take the form of a discrete electrode surrounded by insulating layer 1350. In at least some instances, distal ablation tip 1324 takes the form of a distal ablation tip electrode 1324.

[0122] FIG. 31 is a side view of another example system 1410 that may be similar in form and function to other systems disclosed herein. System 1410 includes shaft 1412. One or more ring electrodes 1422 may be disposed along shaft 1412. Distal ablation tip 1424 may be disposed at the distal end of shaft 1412. Electrode assembly 1430 may be disposed along distal ablation tip 1424. Electrode assembly 1430 may include insulating layer 1450 and a plurality of electrode regions 1432a/1432b. In at least some embodiments, electrode regions 1432a/1432b may be a pair of bipolar electrodes. In at least some instances, distal ablation tip 1424 takes the form of a distal ablation tip electrode 1424.

[0123] FIGS. 32-33 illustrate another example system 1510 that may be similar in form and function to other systems disclosed herein. System 1510 includes shaft 1512. One or more ring electrodes 1522 may be disposed along shaft 1512. Distal ablation tip 1524 may be disposed at the distal end of shaft 1512. In at least some instances, distal ablation tip 1524 takes the form of a distal ablation tip electrode 1524.

[0124] Electrode assembly 1530 may be disposed along distal ablation tip 1524. In this example, electrode assembly 1530 may extend to and/or along the distal end of distal ablation tip 1524 as can be seen in FIG. 33, which is an end view of system 1510. Here it can be seen that electrode assembly 1530 may include insulating layer 1550 and electrode region 1532.

[0125] FIG. 34 is a side view of another example system 1610 that may be similar in form and function to other systems disclosed herein. System 1610 includes shaft 1612. One or more ring electrodes 1622 may be disposed along shaft 1612. Distal ablation tip 1624 may be disposed at the distal end of shaft 1612. In at least some instances, distal ablation tip 1624 takes the form of a distal ablation tip electrode 1624.

[0126] Electrode assembly 1630 may be disposed along distal ablation tip 1624. Electrode assembly 1630 may include insulating layer 1650 and electrode region 1632.

[0127] FIG. 35 is an end view of another example system 1710 that may be similar in form and function to other systems disclosed herein. System 1710 includes distal ablation tip 1724. Electrode assembly 1730 may be disposed along distal ablation tip 1724. Electrode assembly 1730 may include insulating layer 1750 and electrode region 1732. In at least some instances, distal ablation tip 1724 takes the form of a distal ablation tip electrode 1724.

[0128] FIG. 36 is a side view of another example system 1810 that may be similar in form and function to other systems disclosed herein. System 1810 includes shaft 1812. One or more ring electrodes 1822 may be disposed along shaft 1812. Distal ablation tip 1824 may be disposed at the distal end of shaft 1812. In at least some instances, distal ablation tip 1824 takes the form of a distal ablation tip electrode 1824.

[0129] Electrode assembly 1830 may be disposed along distal ablation tip 1824. Electrode assembly 1830 may include a plurality of insulating layers 1850 and electrode region 1832 disposed between insulating layers 1850.

[0130] FIG. 37 is a side view of another example system 1910 that may be similar in form and function to other systems disclosed herein. System 1910 includes shaft 1912. One or more ring electrodes 1922 may be disposed along shaft 1912. Distal ablation tip 1924 may be disposed at the distal end of shaft 1912. In at least some instances, distal ablation tip 1924 takes the form of a distal ablation tip electrode 1924.

[0131] Electrode assembly 1930 may be disposed along distal ablation tip 1924. Electrode assembly 1930 may include a plurality of insulating layers 1950 and a plurality of electrode regions 1932a/1932b disposed between insulating layers 1950.

[0132] The materials that can be used for the various components of system 10 and/or other systems disclosed herein (e.g., shafts, micro-electrodes, distal ablation tip electrodes, flexible circuits, substrates, etc.) may include metals, metal alloys, polymers, metal-polymer composites, ceramics, combinations thereof, and the like, or other suitable material. Some examples of suitable polymers may include polytetrafluoroethylene (PTFE), ethylene tetrafluoroethylene (ETFE), fluorinated ethylene propylene (FEP), polyoxymethylene (POM, for example, DELRIN® available from DuPont), polyether block ester, polyurethane (for example, Polyurethane 85A), polypropylene (PP), polyvinylchloride (PVC), polyether-ester (for example, ARNITEL® available from DSM Engineering Plastics), ether or ester based copolymers (for example, butylene/poly(alkylene ether) phthalate and/or other polyester elastomers such as HYTREL® available from DuPont), polyamide (for example, DURETHAN® available from Bayer or CRISTAMID® available from Elf Atochem), elastomeric polyamides, block polyamide/ethers, polyether block amide (PEBA, for example available under the trade name PEBA®), ethylene vinyl acetate copolymers (EVA), silicones, polyethylene (PE), Marlex high-density polyethylene, Marlex low-density polyethylene, linear low density polyethylene (for example REXELL®), polyester, polybutylene terephthalate (PBT), polyethylene terephthalate (PET), polytrimethylene terephthalate, polyethylene naphthalate (PEN), polyetheretherketone (PEEK), polyimide (PI), polyetherimide (PEI), polyphenylene sulfide (PPS), polyphenylene oxide (PPO), poly paraphenylene terephthalamide (for example, KEVLAR®), polysulfone, nylon, nylon-

12 (such as GRILAMID® available from EMS American Grilon), perfluoro(propyl vinyl ether) (PFA), ethylene vinyl alcohol, polyolefin, polystyrene, epoxy, polyvinylidene chloride (PVdC), poly(styrene-*b*-isobutylene-*b*-styrene) (for example, SIBS and/or SIBS 50A), polycarbonates, ionomers, biocompatible polymers, other suitable materials, or mixtures, combinations, copolymers thereof, polymer/metal composites, and the like.

[0133] Some examples of suitable metals and metal alloys include stainless steel, such as 304V, 304L, and 316LV stainless steel; mild steel; nickel-titanium alloy such as linear-elastic and/or super-elastic nitinol; other nickel alloys such as nickel-chromium-molybdenum alloys (e.g., UNS: N06625 such as INCONEL® 625, UNS: N06022 such as HASTELLOY® C-22®, UNS: N10276 such as HASTELLOY® C276®, other HASTELLOY® alloys, and the like), nickel-copper alloys (e.g., UNS: N04400 such as MONEL® 400, NICKELVAC® 400, NICORROS® 400, and the like), nickel-cobalt-chromium-molybdenum alloys (e.g., UNS: R30035 such as MP35-N® and the like), nickel-molybdenum alloys (e.g., UNS: N10665 such as HASTELLOY® ALLOY B2®), other nickel-chromium alloys, other nickel-molybdenum alloys, other nickel-cobalt alloys, other nickel-iron alloys, other nickel-copper alloys, other nickel-tungsten or tungsten alloys, and the like; cobalt-chromium alloys; cobalt-chromium-molybdenum alloys (e.g., UNS: R30003 such as ELGILOY®, PHYNOX®, and the like); platinum enriched stainless steel; titanium; combinations thereof; and the like; or any other suitable material.

[0134] As alluded to herein, within the family of commercially available nickel-titanium or nitinol alloys, is a category designated “linear elastic” or “non-super-elastic” which, although may be similar in chemistry to conventional shape memory and super elastic varieties, may exhibit distinct and useful mechanical properties. Linear elastic and/or non-super-elastic nitinol may be distinguished from super elastic nitinol in that the linear elastic and/or non-super-elastic nitinol does not display a substantial “superelastic plateau” or “flag region” in its stress/strain curve like super elastic nitinol does. Instead, in the linear elastic and/or non-super-elastic nitinol, as recoverable strain increases, the stress continues to increase in a substantially linear, or a somewhat, but not necessarily entirely linear relationship until plastic deformation begins or at least in a relationship that is more linear than the super elastic plateau and/or flag region that may be seen with super elastic nitinol. Thus, for the purposes of this disclosure linear elastic and/or non-super-elastic nitinol may also be termed “substantially” linear elastic and/or non-super-elastic nitinol.

[0135] In some cases, linear elastic and/or non-super-elastic nitinol may also be distinguishable from super elastic nitinol in that linear elastic and/or non-super-elastic nitinol may accept up to about 2-5% strain while remaining substantially elastic (e.g., before plastically deforming) whereas super elastic nitinol may accept up to about 8% strain before plastically deforming. Both of these materials can be distinguished from other linear elastic materials such as stainless steel (that can also be distinguished based on its composition), which may accept only about 0.2 to 0.44 percent strain before plastically deforming.

[0136] In some embodiments, the linear elastic and/or non-super-elastic nickel-titanium alloy is an alloy that does not show any martensite/austenite phase changes that are detectable by differential scanning calorimetry (DSC) and dynamic

metal thermal analysis (DMTA) analysis over a large temperature range. For example, in some embodiments, there may be no martensite/austenite phase changes detectable by DSC and DMTA analysis in the range of about -60 degrees Celsius (° C.) to about 120° C. in the linear elastic and/or non-super-elastic nickel-titanium alloy. The mechanical bending properties of such material may therefore be generally inert to the effect of temperature over this very broad range of temperature. In some embodiments, the mechanical bending properties of the linear elastic and/or non-super-elastic nickel-titanium alloy at ambient or room temperature are substantially the same as the mechanical properties at body temperature, for example, in that they do not display a super-elastic plateau and/or flag region. In other words, across a broad temperature range, the linear elastic and/or non-super-elastic nickel-titanium alloy maintains its linear elastic and/or non-super-elastic characteristics and/or properties.

[0137] In some embodiments, the linear elastic and/or non-super-elastic nickel-titanium alloy may be in the range of about 50 to about 60 weight percent nickel, with the remainder being essentially titanium. In some embodiments, the composition is in the range of about 54 to about 57 weight percent nickel. One example of a suitable nickel-titanium alloy is FHP-NT alloy commercially available from Furukawa Techno Material Co. of Kanagawa, Japan. Some examples of nickel titanium alloys are disclosed in U.S. Pat. Nos. 5,238,004 and 6,508,803, which are incorporated herein by reference. Other suitable materials may include ULTANIUM™ (available from Neo-Metrics) and GUM METAL™ (available from Toyota). In some other embodiments, a super-elastic alloy, for example a superelastic nitinol can be used to achieve desired properties.

[0138] In at least some embodiments, components of system 10 may also be doped with, made of, or otherwise include a radiopaque material. Radiopaque materials are understood to be materials capable of producing a relatively bright image on a fluoroscopy screen or another imaging technique during a medical procedure. This relatively bright image aids the user of system 10 in determining its location. Some examples of radiopaque materials can include, but are not limited to, gold, platinum, palladium, tantalum, tungsten alloy, polymer material loaded with a radiopaque filler, and the like. Additionally, other radiopaque marker bands and/or coils may also be incorporated into the design of system 10 to achieve the same result.

[0139] In some embodiments, a degree of Magnetic Resonance Imaging (MRI) compatibility is imparted into system 10. For example, components of system 10, or portions thereof, may be made of a material that does not substantially distort the image and create substantial artifacts (e.g., gaps in the image). Certain ferromagnetic materials, for example, may not be suitable because they may create artifacts in an MRI image. Components of system 10, or portions thereof, may also be made from a material that the MRI machine can image. Some materials that exhibit these characteristics include, for example, tungsten, cobalt-chromium-molybdenum alloys (e.g., UNS: R30003 such as ELGILOY®, PHYNOX®, and the like), nickel-cobalt-chromium-molybdenum alloys (e.g., UNS: R30035 such as MP35-N® and the like), nitinol, and the like, and others.

[0140] It should be understood that this disclosure is, in many respects, only illustrative. Changes may be made in details, particularly in matters of shape, size, and arrangement

of steps without exceeding the scope of the disclosure. This may include, to the extent that it is appropriate, the use of any of the features of one example embodiment being used in other embodiments. The invention's scope is, of course, defined in the language in which the appended claims are expressed.

[0141] Various modifications and additions can be made to the exemplary embodiments discussed without departing from the scope of the present invention. For example, while the embodiments described above refer to particular features, the scope of this invention also includes embodiments having different combinations of features and embodiments that do not include all of the described features. Accordingly, the scope of the present invention is intended to embrace all such alternatives, modifications, and variations as fall within the scope of the claims, together with all equivalents thereof.

We claim:

1. A catheter for use in cardiac mapping and/or ablation, the catheter comprising:

an elongate catheter shaft having a distal ablation electrode region;

an electrode assembly coupled to the distal ablation electrode region; and

wherein the electrode assembly includes a flexible circuit having one or more electrodes disposed thereon.

2. The catheter of claim 1, wherein the distal ablation electrode region has an opening formed therein and wherein the electrode assembly extends through the opening.

3. The catheter of claim 1, wherein the electrode assembly includes a region that is disposed along a distal end of the distal ablation electrode region.

4. The catheter of claim 1, wherein the electrode assembly includes a plurality of arm regions and wherein each of the arm regions includes at least one electrode.

5. The catheter of claim 4, wherein the electrode assembly includes three or more arm regions.

6. The catheter of claim 4, wherein the electrode assembly includes four or more arm regions.

7. The catheter of claim 1, wherein the electrode assembly includes a mechanical locking end region that is capable of mechanically securing the electrode assembly to the distal ablation electrode region.

8. The catheter of claim 7, wherein the distal ablation electrode region has an opening formed therein and wherein the mechanical locking end region extends through the opening.

9. The catheter of claim 1, wherein the catheter shaft includes an inner channel, wherein the distal ablation electrode region includes a first opening and a second opening, and wherein the electrode assembly extends along the inner channel, through the first opening, along an outer surface of the distal ablation electrode region, and through the second opening.

10. The catheter of claim 1, wherein the electrode assembly is adhesively bonded to the distal ablation electrode region.

11. The catheter of claim 1, wherein the electrode assembly includes one or more electrode regions and one or more electrically insulated regions.

12. The catheter of claim 1, wherein the electrode assembly extends circumferentially around the distal ablation electrode region.

13. The catheter of claim 1, wherein the electrode assembly is designed to bow radially outward from the distal ablation electrode region.

14. The catheter of claim 1, wherein the distal ablation electrode region includes a platinum ablation tip electrode.

15. A method for manufacturing a medical device, the method comprising:

inserting an electrode assembly into a channel formed within a distal ablation tip of a catheter;

wherein the electrode assembly includes a flexible circuit having one or more electrodes disposed thereon;

wherein the distal ablation tip includes a first opening and a second opening; and

extending the electrode assembly through the first opening, along an outer surface of the distal ablation tip, and through the second opening.

16. A catheter for use in cardiac mapping and/or ablation, the catheter comprising:

an elongate catheter shaft having an inner channel and a distal end region;

a distal ablation tip capable of ablating tissue disposed at the distal end region;

an electrode assembly coupled to the distal ablation tip; wherein the electrode assembly includes a flexible circuit having one or more electrodes disposed thereon;

wherein the distal ablation electrode region includes a first opening and a second opening;

wherein the electrode assembly extends along the inner channel, through the first opening, along an outer surface of the distal ablation tip, and through the second opening.

17. The catheter of claim 16, wherein the electrode assembly includes a region that is disposed along a distal end of the distal ablation tip.

18. The catheter of claim 16, wherein the electrode assembly includes a plurality of arm regions and wherein each of the arm regions includes at least one electrode.

19. The catheter of claim 16, wherein the electrode assembly includes a mechanical locking end region that is capable of mechanically securing the electrode assembly to the distal ablation tip.

20. The catheter of claim 19, wherein the mechanical locking end region extends through the first opening, the second opening, or both.

* * * * *

专利名称(译)	具有耦合到消融尖端的柔性电极组件的医疗装置		
公开(公告)号	US20160113712A1	公开(公告)日	2016-04-28
申请号	US14/922023	申请日	2015-10-23
[标]申请(专利权)人(译)	波士顿科学西美德公司		
申请(专利权)人(译)	BOSTON SCIENTIFIC SCIMED INC.		
当前申请(专利权)人(译)	BOSTON SCIENTIFIC SCIMED INC.		
[标]发明人	CHEUNG DESMOND POTOSKY JOHN C MARECKI ANDREW T KIM ISAAC J MIRIGIAN MARK D		
发明人	CHEUNG, DESMOND POTOSKY, JOHN C. MARECKI, ANDREW T. KIM, ISAAC J. MIRIGIAN, MARK D.		
IPC分类号	A61B18/14 A61B5/00 A61B5/042		
CPC分类号	A61B18/1492 A61B5/0422 A61B5/6852 A61B2017/00526 A61B2018/00577 A61B2018/00642 A61B2018/00839 A61B2018/00351 A61B5/6859 A61B2018/1465 A61B2018/1495 A61B2562/166		
优先权	62/068334 2014-10-24 US		
其他公开文献	US10603105		
外部链接	Espacenet USPTO		

摘要(译)

公开了用于制造和使用医疗装置的医疗装置和方法。示例性医疗装置可包括用于心脏标测和/或消融的导管。导管可包括细长导管轴，其具有能够消融组织的远侧消融电极区域。电极组件可以耦合到远侧消融电极区域。电极组件可包括柔性电路，柔性电路上设置有一个或多个电极。

