



US 20140221792A1

(19) **United States**

(12) **Patent Application Publication**
Miller et al.

(10) **Pub. No.: US 2014/0221792 A1**
(43) **Pub. Date: Aug. 7, 2014**

(54) **HYDRATION MONITORING APPARATUS**
(71) Applicants: **Devin Warner Miller**, Cleveland, OH (US); **David Rich Miller**, Morgan, UT (US)
(72) Inventors: **Devin Warner Miller**, Cleveland, OH (US); **David Rich Miller**, Morgan, UT (US)

(52) **U.S. Cl.**
CPC *A61B 5/0537* (2013.01); *A61B 5/01* (2013.01); *A61B 5/0075* (2013.01); *A61B 8/00* (2013.01); *A61B 5/024* (2013.01); *A61B 5/14546* (2013.01); *A61B 5/1118* (2013.01); *A61B 5/6801* (2013.01)
USPC **600/309**; 600/300; 600/547; 600/549; 600/476; 600/438; 600/508; 600/595

(21) Appl. No.: **13/756,742**
(22) Filed: **Feb. 1, 2013**

Publication Classification

(51) **Int. Cl.**
A61B 5/053 (2006.01)
A61B 5/00 (2006.01)
A61B 5/11 (2006.01)
A61B 5/024 (2006.01)
A61B 5/145 (2006.01)
A61B 5/01 (2006.01)
A61B 8/00 (2006.01)

(57) **ABSTRACT**
A hydration monitoring apparatus is disclosed. The hydration monitoring apparatus comprises at least one sensor and an analysis unit. The hydration monitoring apparatus may take at least one biometric, biological, and/or physiological measurement of an individual and measures the hydration level, dehydration level or status, or bodily fluid level of an individual. The hydration monitoring apparatus indicates the hydration level, dehydration level or status, or bodily fluid level of an individual based on one or more biometric, biological, and/or physiological measurements. In one embodiment of the invention, the hydration monitoring apparatus determines whether to inform the user of their hydration level, dehydration level or status, or bodily fluid level. In one embodiment the hydration monitoring apparatus further comprises an informing device that informs the individual that the individual is approaching dehydration.

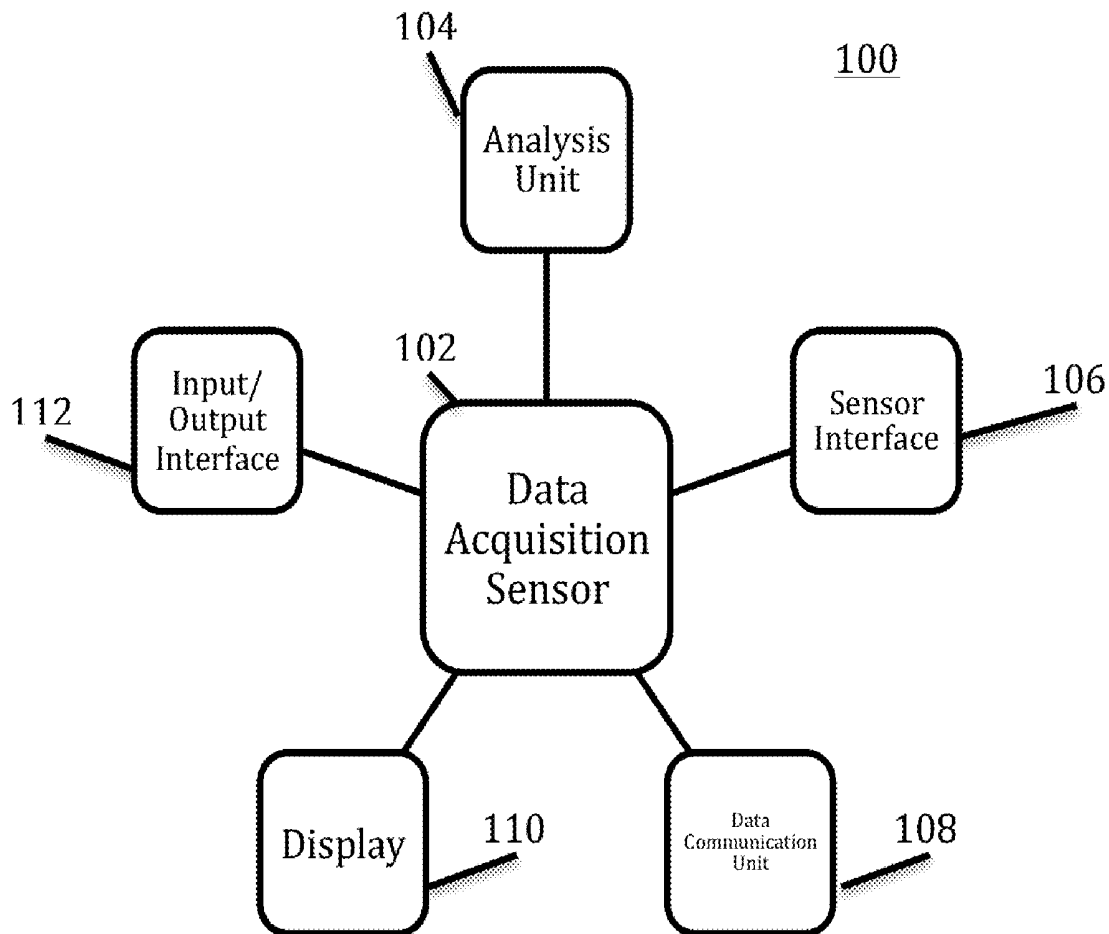

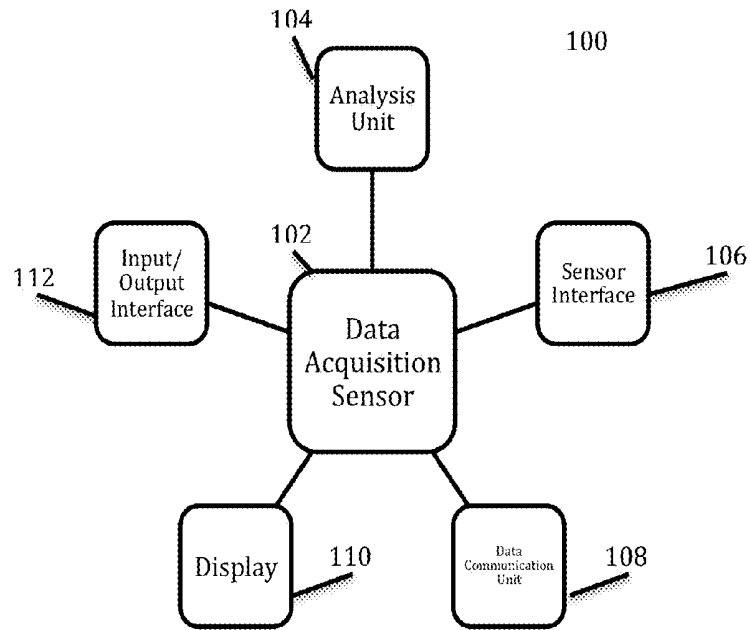

Fig. 1

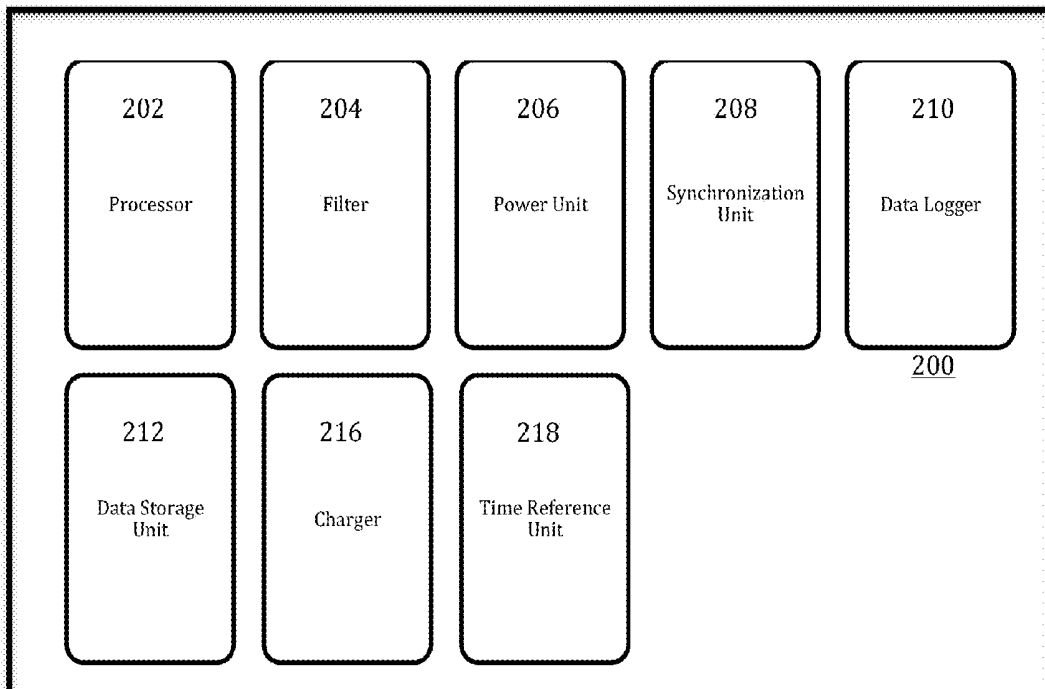

Fig. 2

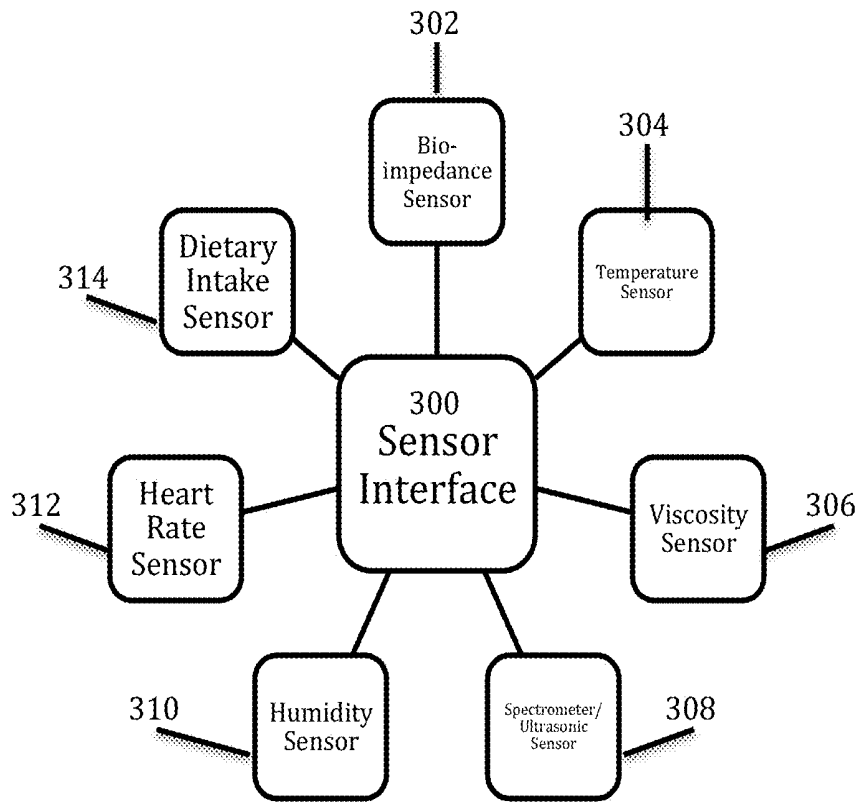

Fig. 3

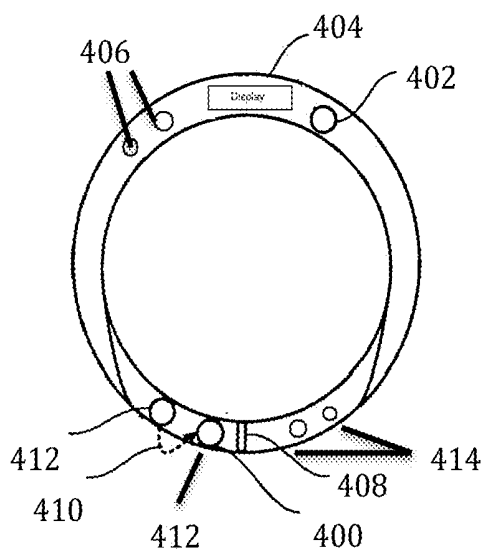

Fig. 4

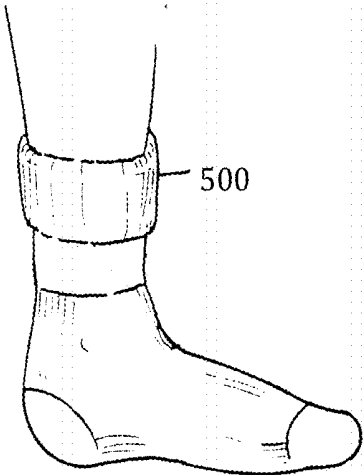

Fig. 5a

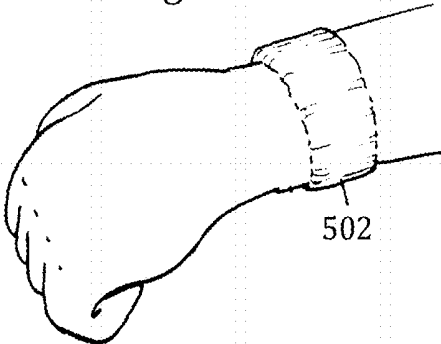

Fig. 5b

504

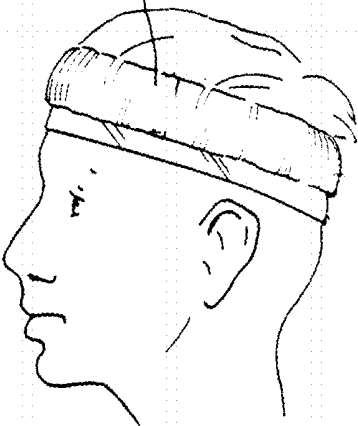

Fig. 5c

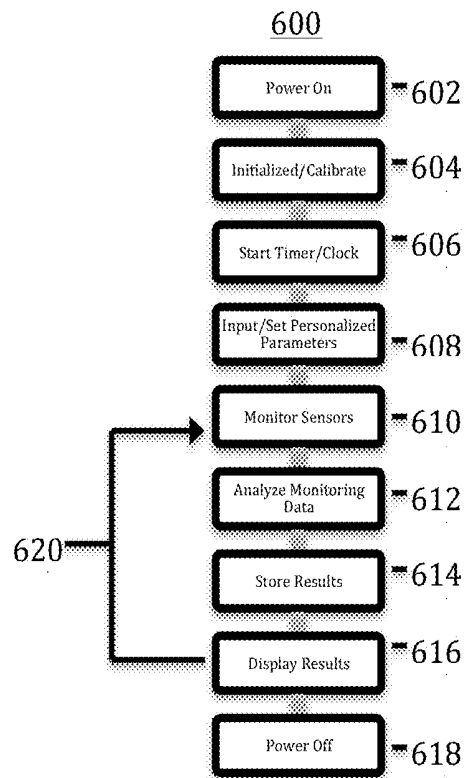

Fig. 6

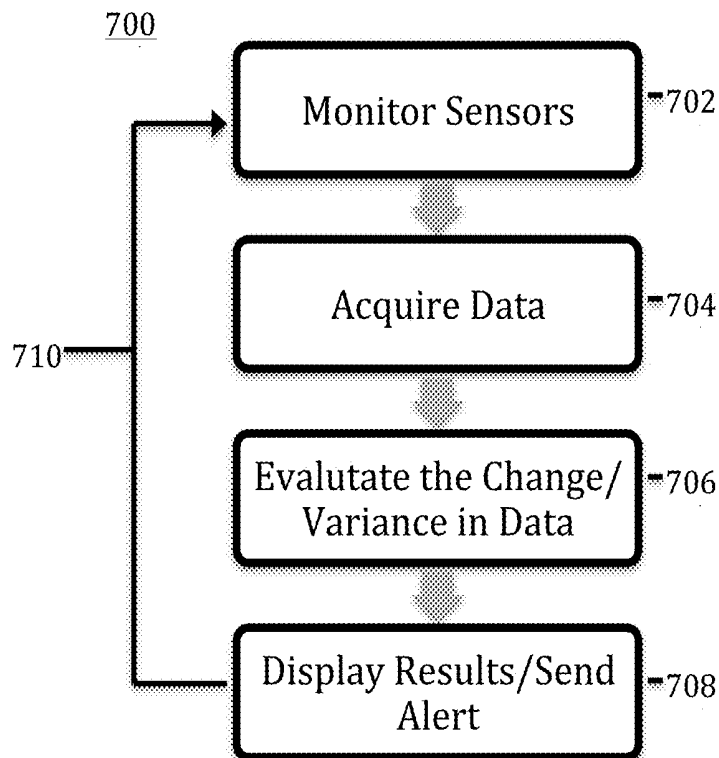

Fig. 7

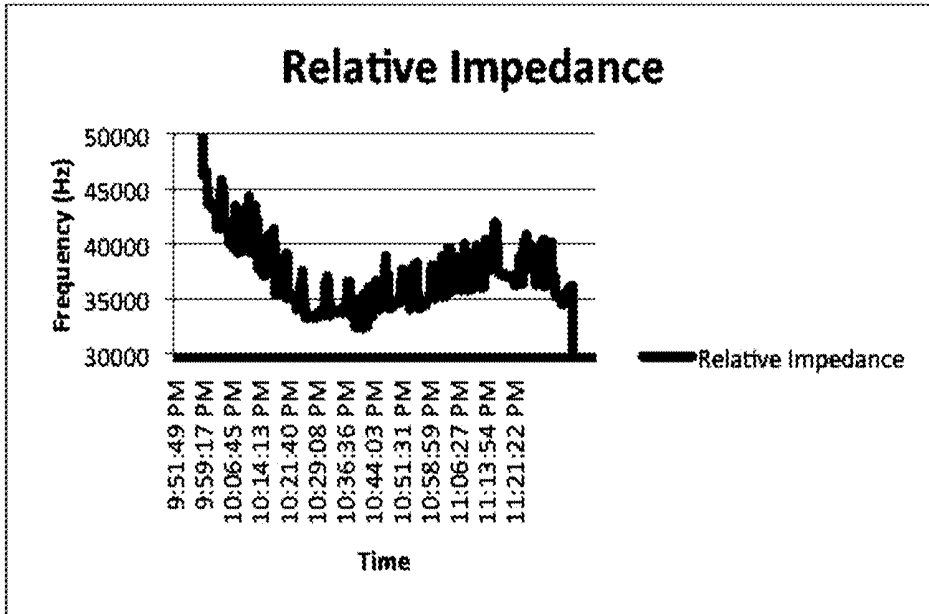

Fig. 8a

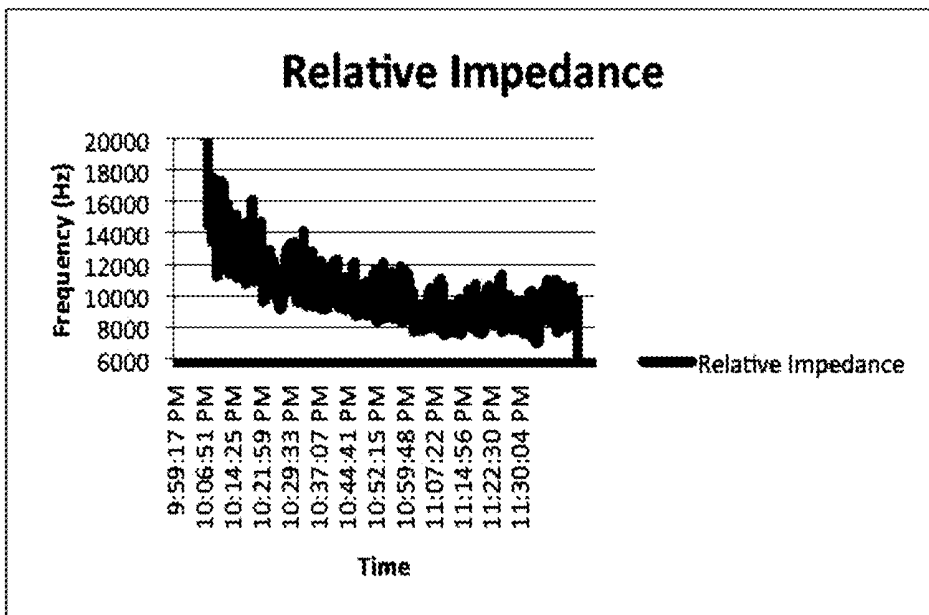

Fig. 8b

HYDRATION MONITORING APPARATUS

BACKGROUND

[0001] Dehydration is a condition in which water in a living body decreases below the individual's normal functioning level. Dehydration often occurs when an individual is exercising for extended periods of time, intakes little or no water, or the temperature rises to a point where an individual cannot excrete enough sweat to maintain their normal body temperature. Persons that regularly exert themselves in low humidity and/or high temperature conditions and/or for extended periods of time are prone to experience dehydration or dehydration symptoms. Elderly persons and children are also especially prone to experience dehydration or dehydration symptoms.

[0002] In less severe cases of dehydration, an individual's ability to perform tasks will begin to deteriorate. For example, in the case of long distance endurance athletes, an individual that becomes dehydrated by loss of as little as 2% body weight may begin to have their performance impaired. Losses in excess of 5% of body weight can decrease the capacity of an individual to perform a task by as much as 30%.

[0003] Another group of people in danger of dehydration are individuals with dysentery. Dysentery is a gastrointestinal disorder characterized by inflammation of the intestines, particularly the colon. Diarrhea and vomiting are typical side effects of patients with dysentery, especially in the case of small children. As dysentery patients suffer from diarrhea and vomiting they are unable to maintain a proper hydration level, causing them to become dehydrated. Such a dehydrated state exasperates the patient's condition, causing their health to further deteriorate and prolong recovery time.

[0004] If a dehydrated individual continues untreated, the effects of dehydration will progressively become worse until the individual is in a serious dehydrated condition. Typically when at least one third of the water in a living body is lost, the body temperature regulation ceases to function correctly. This dysfunction causes the body temperature to increase, which causes the water level in the living body to be further reduced and thus the body enters an uncontrolled spiral. As the body becomes more dehydrated, illnesses such as heat cramping, heat stroke, heat exhaustion, desert syndrome, and heatstroke can occur. In severe cases of dehydration organs do not function properly or may fail.

[0005] Thus, it is desirable that an individual's hydration level is monitored regularly and any dehydration is detected in the early stages before an individual's performance levels are impacted or they reach a serious dehydration condition. However, people are often not aware of dehydration symptoms at early stages, based only on self-awareness. As a result, dehydration symptoms are left untreated until an individual feels dizzy or weak and thus realizes something is wrong. By the time an individual feels dizzy or weak they are already in a serious dehydration condition. When an individual reaches a serious dehydration condition, serious medical treatment may be required and the window to treat the individual may become severely shortened.

SUMMARY

[0006] This summary is provided to introduce a selection of concepts in a simplified form that are further described below in the Detailed Description. This summary is not intended to

identify key factors or essential features of the claimed individual matter, nor is it intended to be used to limit the scope of the claimed individual matter.

[0007] There are various ways that have been attempted in detecting the early stages of dehydration that have yielded unsuccessful results. An object of the present invention is to provide hydration information about an individual by monitoring an individual's internal bodily measurements, biometric, biological, and/or physiological state. The hydration condition of an individual also may be affected by their surrounding environment and by monitoring the external surroundings of an individual and/or the environmental conditions approximate an individual, wherein appropriate corrections and normalizations to the biological data may be performed. The individual's biometric, biological, and/or physiological state may be monitored in real-time by using one or a plurality of sensors. The information, data, or measurements taken by one or a plurality of sensors may be analyzed separately or in combination, such as a multimodal analysis or multivariate analysis, to determine an individual's hydration level or dehydration state as well as other important and useful parameters such as body temperature, hematocrit, electrolyte concentrations and so on.

DESCRIPTION OF THE DRAWINGS

[0008] FIG. 1 is a block diagram of a hydration monitoring apparatus according to one embodiment of the present invention;

[0009] FIG. 2 is a block diagram of a data acquisition unit according to one embodiment of the present invention;

[0010] FIG. 3 illustrates a sensor interface and a plurality of sensors, interfaces, and displays that are in communication with the sensor interface;

[0011] FIG. 4 illustrates a plurality of sensors embedded on the inner radial and outer radial surface of sweatband according to one embodiment of the present invention;

[0012] FIGS. 5a, 5b, and 5c illustrate a plurality of positions the sweatband could be located on an individual's body.

[0013] FIG. 6 is a flowchart illustrating the action flow of the hydration monitoring apparatus according to one embodiment of the present invention;

[0014] FIG. 7 is a flowchart illustrating the action flow of the monitoring and analysis of an individual for one embodiment of the hydration monitoring apparatus according to the present invention;

[0015] FIG. 8a is a graph illustrating the impedance over time data for a individual that is hydrated;

[0016] FIG. 8b is a graph illustrating the impedance over time data for a individual that is becoming dehydrated;

DETAILED DESCRIPTION

[0017] In one embodiment of the invention, a hydration monitoring apparatus 100 for monitoring an individual's hydration information comprises: a data acquisition unit 102, an analysis unit 104, a sensor interface 106, a data communication unit 108, a display 110, and an input/output interface 112. In another embodiment of the invention, the invention may be a device, system, method, or process.

[0018] The claimed individual matter is now described with reference to the drawings, wherein like reference numerals are used to refer to like elements throughout. In the following description, for purposes of explanation, numerous specific details are set forth in order to provide a thorough understand-

ing of the claimed individual matter. It may be evident, however, that the claimed individual matter may be practiced without these specific details. In other instances, well-known structures and devices are shown in block diagram form in order to facilitate describing the claimed individual matter.

[0019] To the accomplishment of the foregoing and related ends, the following description and annexed drawings set forth certain illustrative aspects and implementations. These are indicative of but a few of the various ways in which one or more aspects may be employed. Other aspects, advantages, and novel features of the disclosure will become apparent from the following detailed description when considered in conjunction with the annexed drawings.

[0020] FIG. 1 shows the components of the hydration monitoring apparatus 100 according to an embodiment of the present invention. FIG. 1 shows that the hydration monitoring apparatus 100 may comprise at least one of a data acquisition unit 102, analysis unit 104, sensor interface 106, data communication unit 108, a display 110, and an input/output interface 112.

[0021] The data acquisition unit 102 is connectable or in communication and receives and/or sends data to at least one of the analysis unit, sensor interface 106, data communication unit 108, input/output interface 112, and the display 110 connected to or in communication with it. The data acquisition unit 102 may be used to gather, store, record, and/or arrange data collected by the sensor interface 106 and/or analysis unit 104.

[0022] Components of the hydration monitoring apparatus 100 may be connected by various interconnects, such as a bus. Such interconnects may include a Peripheral Component Interconnect (PCI), such as PCI Express, a Universal Serial Bus (USB), firewire (IEEE 1394), an optical bus structure, and the like. In another embodiment, components of the hydration monitoring apparatus 100 may be interconnected by a network.

[0023] The hydration monitoring apparatus 100 may comprise a sensor interface 106 that has at least one sensor, monitor, or apparatus connected to it for data collection. The sensor interface 106 is in communication with the data acquisition unit 102.

[0024] The hydration monitoring apparatus 100 may comprise a data communication unit 108 that can send and receive information between the data acquisition unit 102 and external devices. In one embodiment of the invention, the data communication unit 108 comprises a transceiver. Alternatively, the data communication unit 108 may send and receive data collected by the hydration monitoring apparatus to an external device via a wireless connection or a wired connection. The wireless connection of the data communication unit 108 may transmit the data via such communications systems or connections including a wireless network, Bluetooth, Zigbee, cellular network, and/or other communication systems or devices. The wired connection of the data communication unit 108 may transmit the data via such communications systems or connections including a USB interface, Ethernet connection, a headphone jack, and/or other communication systems or devices. In another embodiment the data communications unit may store the collected data on a non-transitory computer readable medium such as a Compact Disc (CD), Digital Video Disc (DVD), hard drive, or USB storage device, and/or other non-transitory computer readable mediums.

[0025] In one embodiment of the invention, the data communication unit 108 may also comprise communication con-

nection(s) that allows the hydration monitoring apparatus 100 to communicate with other devices. Communication connection(s) may include, but is not limited to, a modem, a Network Interface Card (NIC), an integrated network interface, a radio frequency transmitter/receiver, an infrared port, a USB connection, or other interfaces for connecting the hydration monitoring apparatus 100 to other computing devices. The data communication unit 108 may transmit and/or receive communication media.

[0026] The hydration monitoring apparatus 100 may comprise an input/output interface 112 in communication with the data acquisition unit 102. The input/output interface 112 may allow for the exchange of information and/or data with external devices, systems, and/or apparatuses. The input device(s) may include devices such as a keyboard, mouse, pen, voice input device, touch input device, infrared cameras, video input devices, and/or any other input device. The output device(s) may include device(s) such as a display, speaker, printer, and/or any other output device(s). In one embodiment, an input device or an output device from another computing device may be used as an input device(s) or an output device(s) for the input/output interface 112.

[0027] The hydration monitoring apparatus 100 may comprise a display 110 for presenting information communicated from the data acquisition unit 102 to an individual. The display 110 may comprise a computer, cellular phone, touch screen, short message service (SMS), or other display devices. In one embodiment of the invention, the output device comprises an informing device or display that sends an indication message, which informs or alerts the individual of their body water level, hydration level, dehydration condition, or that the individual is dehydrated or is approaching dehydration.

[0028] In one embodiment of the invention, input/output interface 112 may include a variety of features and/or functionality. For example, Input/output interface 112 may include additional storage (e.g., removable and/or non-removable) including, but not limited to, magnetic storage, optical storage, and the like. In one embodiment of the invention, computer readable instructions to implement one or more embodiments provided herein may be in storage on a non-tangible computer readable medium in the data communication unit 108 or data acquisition unit 102. FIG. 2 shows one embodiment of a data storage unit 212. The data storage unit 212 or data logger 210 of the data acquisition unit 200 may also store other computer readable instructions to implement an operating system, an application program, and the like. Computer readable instructions may be loaded in memory for execution by processor 202 of the data acquisition unit 200.

[0029] In one embodiment of the invention, a sensor interface 106 supplies an alternating current to at least one connected sensor and/or contact point of the at least one sensor. Alternatively the sensor interface 106 may comprise an oscillator. The sensor interface 106 may be arranged to receive synchronization signals, adjust the frequency of the oscillator, and/or adjust the times at which data is collected using an attached sensor(s) and/or contact point(s) of the sensor(s). The synchronization signals may also be used to synchronize the times at which data or information is collected from a plurality of attached sensors.

[0030] The term "non-transitory computer readable medium" as used herein includes computer storage media. Non-transitory computer readable media includes volatile

and nonvolatile, removable and non-removable media implemented in any method or technology for storage of information such as computer readable instructions or other data. The data storage unit **212** is an example of a non-transitory computer readable media. Non-transitory computer readable media includes, but is not limited to, RAM, ROM, EEPROM, flash memory or other memory technology, CD-ROM, Digital Versatile Disks (DVDs) or other optical storage, magnetic cassettes, magnetic tape, magnetic disk storage or other magnetic storage devices, or any other medium which can be used to store the desired information and which can be accessed by the data acquisition unit **102**. Any such non-transitory computer readable media may be part of the hydration monitoring apparatus **100**.

[0031] Those skilled in the art will realize that storage devices utilized to store computer readable instructions may be distributed across a network. For example, a computing device accessible via a network may store computer readable instructions to implement one or more embodiments provided herein. The hydration monitoring apparatus **100** may access computing device(s) and download a part or all of the computer readable instructions for execution. Alternatively, the computing device(s) may download pieces of the computer readable instructions, as needed, or some instructions may be executed at computing device(s) and some at hydration monitoring apparatus **100**.

[0032] In one embodiment the computing device(s) include, but are not limited to, personal computers, server computers, hand-held or laptop devices, mobile devices (such as mobile phones, Personal Digital Assistants (PDAs), media players, and the like), multiprocessor systems, consumer electronics, mini computers, mainframe computers, distributed computing environments that include any of the above systems or devices, and the like.

[0033] In one embodiment, the data acquisition unit **102** and/or the hydration monitoring apparatus **100** includes at least one processor, such as processor **202**, and/or memory. The memory may be volatile (such as RAM, for example), non-volatile (such as ROM, flash memory, etc., for example) or some combination of the two.

[0034] FIG. 2 further shows one embodiment of the data acquisition unit **200**. The data acquisition unit **200** may comprise a processor **202**, filter unit **204**, power unit **206**, synchronization unit **208**, a data logger **210**, data storage unit **212**, a charger **216**, and a time referencing unit **218**.

[0035] In one embodiment of the invention, the processor **202** may comprise a central processor to process the data and/or information of the other components that comprise the data acquisition unit **200** or the units, interfaces, and/or devices attached to or in communication with the data acquisition unit **200**.

[0036] In one embodiment of the invention, the filter unit **204** of the data acquisition unit **200** may be used to filter the data received from the units and interfaces in communication unit. The filter unit **204** may filter, categorize, modify, or clean received information and/or data, such as data received or transmitted to and from the sensor interface **106**, the data communications unit **108**, and the input/output interface **112**.

[0037] In one embodiment of the invention, the data acquisition unit **200** contains a power unit **206** that supplies power to the data acquisition unit **200** and/or the components of the hydration monitoring apparatus **100**. The power unit **206** may comprise a battery to supply power and a charging unit that charges the battery. Alternatively, data acquisition unit **200**

and/or the hydration monitoring apparatus **100** are connectable to an energy source that powers the hydration monitoring apparatus **100**. In one embodiment of the invention, the charger **216** may be used to recharge a battery or other energy source of the power unit **206**.

[0038] In one embodiment of the invention, the synchronization unit **208** of the data acquisition unit **200** may be used to synchronize the data and information received and transmitted between the data acquisition unit **200** and the connected devices, interfaces, and units.

[0039] In one embodiment of the invention, the data acquisition unit **200** may comprise a data logger **210**, wherein the data logger **210** tracks, records, and stores data collected by the data acquisition unit **200** using a non-transitory computer readable medium.

[0040] In one embodiment of the invention, the data acquisition unit **200** comprises a time referencing unit **218** that generates time reference data usable to control the time at which data is collected from the sensor interface **106**. The time referencing unit **218** may also be used to calculate spatial and/or temporal derivatives between information received from the sensor interface **106**. In one embodiment of the invention, the time referencing unit **218** may keep track of the calendar time, such as a clock. Alternatively, the time referencing unit **218** may act as a timer, keeping track of a lapsed time or decrementing from a defined time to zero. The timer of the time referencing unit **218** may be used to collect information or data from the sensor interface **106** for a defined period of time or to record how long the sensor interface **106** collects data.

[0041] In one embodiment of the invention, the data acquisition unit **200** receives and/or stores at least one executable program in a data storage unit **212** for execution on a processor **202** of the data acquisition unit **200**.

[0042] FIG. 3 shows a plurality of sensors that may be attached or in communication with the sensor interface **300**. The sensor interface **300** has at least one sensor attached or in communication with it for data and/or information collection and/or biometric, biological, and/or physiological measurement collection. The attached sensors include at least one of: an impedance sensor **302**, a temperature sensor **304**, a viscosity sensor **306**, a spectrometer or ultrasonic sensor **308**, a humidity sensor **310**, a heart rate sensor **312**, and a dietary intake sensor **314**. The sensor interface **300** may alternatively or in addition include: an activity sensor, a communication interface, a data input/output interface, a sodium level sensor, and/or a fluid intake sensor.

[0043] The sensors may be attached to the sensor interface **300** using a wireless or wired communication system. In one embodiment of the invention, the at least one sensor comprises at least one contact point that is attached or otherwise connected to an individual. The at least one sensor or contact point of the sensor is attached, embedded, implanted, or otherwise connected to or in contact with an individual. In one embodiment of the invention, one or more of the sensors or contact points of the sensors are mounted or adhering sensors or contact points that are attached to the skin or body of an individual. Alternatively, the sensors or contact points may be embedded in a device or apparatus that is mounted, adheres to, and/or attaches to an individual's body, clothing, or other wearable material. In one embodiment of the invention, the number of contact points and/or the spacing of the contact points of a sensor may vary to enable the sensor(s) or the sensor interface **300** to take measurements and/or monitor

along the skin surface of an individual and/or at varying or defined depths of an individual's tissue, interstitial tissue, blood, organs, muscles, vascular system, circulatory system, or other compartments, systems, and/or parts of the individual's body. As the hydration level of an individual changes, the water, interstitial fluid, or other bodily fluid of various parts, compartments, areas, or systems of an individual changes or varies. In one embodiment of the invention, the number of contact points and/or the spacing of the contact points of a sensor may vary to enable the sensors or the sensor interface 300 to take measurements and/or monitor the transfer, pulling, pushing, or movement of water, interstitial fluid, or other bodily fluid from one part, compartment, area, or system of an individual to another part, compartment, area, or system.

[0044] In contrast to an individual suffering from dehydration is an individual suffering from a condition such as overhydration, dilutional hyponatremia, hyponatremia, water poisoning, water excess in the body, and/or water intoxication. Such conditions arise from the body containing too much water. At excessively high levels, water can be considered a poison to an individual's body. If an individual's body has too high of a water level the individual's body, organs, or other systems cannot handle the water or fluid level, bodily functions such as kidney functions deteriorate or stop. Too high of water levels in an individual can also cause the body to lack or be unable to retain and/or absorb the proper nutrients it needs to be healthy. In one embodiment of the invention, the sensor(s), contact point(s) of the sensor(s), or sensor interface 300 may detect and the analysis unit 104 determine if an individual's water or fluid levels are increasing, excessive, too high, changing at too quick or too slow of a rate, or otherwise abnormal. The analysis unit 104 may also determine if the hydration level or condition of an individual is dehydrated, low, normal, high, excessive, or overhydrated.

[0045] The sensor interface 300, the sensor(s) attached to the sensor interface 300, and/or contact point(s) of the sensor (s) may collect the data in real-time, at defined points or periods of time, at random intervals, or at one point in time. In one embodiment of the invention, the sensor interface 300, the at least one sensor attached to the sensor interface 300, and/or contact point(s) of the sensor(s) may measure an absolute value, relative value, or a rate of change of the information and/or data of biometric, biological, and/or physiological measurements taken. In one embodiment the sensor interface 300, the at least one sensor attached to the sensor interface 300, and/or contact point(s) of the sensor(s) may detect and/or monitor at least one of an individual's: hematocrit, electrolyte level, hydration level, sodium level, and sweat level.

[0046] In one embodiment of the invention, the sensor interface 300 or analysis unit 104 may collect, record, store, and/or analyze trends in the data over short periods of time such as seconds, minutes, or hours, and/or extended periods of time, such as days, weeks, months, or years. The collected trend data may be from one or a plurality of the sensors or contact points of the sensors of the sensor interface 300. The analysis unit 104 may use the collected trend data to determine the average rate of change for an individual, group of people, or defined category of people. The group of people may include groups such as families, friends, test groups, selected people with similar traits, or other defined groups. The defined category of people may include categories such as gender, race, ethnicity, age, weight, health condition, diseases, or other defined categories.

[0047] In one embodiment of the invention, the analysis unit 104 uses information and/or data from a plurality of sensors to analyze the hydration level of an individual. In one embodiment of the invention, the information and/or data from each of the plurality of sensors may be analyzed separately and/or independently by the analysis unit 104 to determine the hydration level of an individual. Alternatively, the information and/or data from each of the plurality of sensors may be analyzed in combination by the analysis unit 104 to determine the hydration level of an individual. Alternatively, the information and/or data from each of the plurality of sensors may be aggregated, combined, superimposed, or totaled together by the analysis unit 104 to determine the hydration level of an individual. Alternatively, the information and/or data from each of the plurality of sensors may initially be analyzed independently and then the information is aggregated together and analyzed by the analysis unit 104 to determine the hydration level of an individual. Alternatively, the information and/or data from each of the plurality of sensors may initially be aggregated together and analyzed and then the information be analyzed independently by the analysis unit 104 to determine the hydration level of an individual.

[0048] In one embodiment of the invention, the analysis unit takes a composite of all the information collected from the at least one sensor to determine the hydration level of an individual. By using the composite information or data in totality the analysis unit may be able to adjust the hydration analysis for incorrect, erroneous, or incomplete measurements. For example, an individual's biological measurements may show or reflect that an individual is becoming dehydrated but a change in the environmental surrounding such as a change in temperature or humidity causes the change in the biological measurements to incorrectly depict the hydration level of an individual. Alternatively, a multimodal or multivariate analysis or composite analysis is used in determining an individual's hydration level, where a biological measurement such as an impedance measurement taken at one location, depth, part, compartment, and/or system of the body may individually indicate an incorrect or inaccurate hydration level but when taken in combination with other data or information taken from another sensor(s) shows a correct or accurate hydration level of an individual. Accordingly, one advantage of the analysis unit 104 using a combination data or information from the sensors and/or taking the data or information from the sensors in totality is that false reading, inaccuracies, or errors that would arise from analyzing data or information from sensors separately or independently. Another advantage of the analysis unit 104 using a combination data or information from the sensors and/or taking the data or information from the sensors in totality is that the analysis unit may account for changes in the external surroundings or environment of an individual and how such changes might affect the other data or information collected from the sensor(s) or contact point(s) of the sensor(s).

[0049] In one embodiment of the invention, the analysis unit 104 and/or the sensor interface 300 uses the combination or composite of the data from the sensor(s) or contact point(s) of the sensor to account and/or adjust for any cross-interference from fluid in different compartments, systems, part, or areas of the body or the transfer and/or movement of the fluid between different compartments, systems, part, or areas of the body. In one embodiment of the invention, the analysis unit 104 and/or the sensor interface 300 uses the combination

or composite of the data from the sensor(s) or contact point(s) of the sensor to account and/or adjust for any cross-interference between a plurality of sensors.

[0050] In one embodiment of the invention, the analysis unit 104 and/or the sensor interface 300 uses regression analysis, partial least square fitting, filtering, and/or multi-variate analysis in analyzing the data or information collected from the sensor(s). The regression analysis, partial least square (PLS), filtering, and/or multi-variate analysis may be used for one data or information set of one sensor or a plurality of sensors, a plurality of data or information sets of one sensor or a plurality of sensors, and/or the totality of the data or information set from one or a plurality of sensors. The analysis unit 104 and/or the sensor interface 300 may assign the same weights or importance to the data or information collected from each sensor or contact point of a sensor. Alternatively, the analysis unit 104 and/or the sensor interface 300 may assign different or varying weights or importance to the data or information collected from each sensor or contact point of a sensor. For example, the analysis unit 104 and/or the sensor interface 300 may give the information or data from an impedance sensor weight of seventy and the give the information or data from a temperature sensor weight of thirty from a total of one hundred in when performing an analysis on the data or information collected from the sensor (s). Alternatively, the analysis unit 104 and/or the sensor interface 300 may disregard, negate, or subtract out the data or information collected from one or more of the sensors or contact points of the sensors in performing the analysis. For example, if a the data collected from a sensor is outside the normal, defined, or overage range for an user, group of individuals, or category of individuals, then the data will be disregarded as erroneous and not included the analysis of the data. The weighting of the data may also assume a dynamic form, where weighting factors are continuously adjusted on history, trends, or user input.

[0051] Alternatively, the sensor interface 300 or analysis unit 104 may use the collected data or trends in the data to filter or perform regression analysis on the collected data. The sensor interface 300 or analysis unit 104 may compare the collected data or trends in the data to the current measurements taken by the sensors and/or the recorded change in the data to analyze any atypical or unusual changes in the measurements. Such atypical or unusual changes in the measurements may indicate an error in data collection by the sensor (s), contact point(s) of the sensor(s), and/or sensor interface 300. Alternatively, such atypical or unusual changes in the measurements may indicate a change in the hydration state of an individual, activity level of an individual, or routine of an individual.

[0052] Any of the sensors may use bio-impedance, spectroscopy, and/or an optical device to make measurements. In one embodiment of the invention, bio-impedance may be measured by running an electrical current between a plurality of contact points of a sensor. Any of the sensors of the sensor interface 106 may measure the absolute, relative and/or change of absolute or relative level or value of a biometric, biological, and/or physiological signal or indicator of an individual. The analysis unit evaluates the measured change in the absolute or relative sensor values and bases a dehydration analysis at least in part on the change of the absolute or relative sensor values. Alternatively, the sensor interface 300 or the analysis unit 104 may analyze the variance or change of the present or real-time sensors, contact point(s) of the sen-

sors, and/or sensing or measuring apparatus measurements or values with previously collected measurements or values that are stored in a non-transitory computer readable memory of the hydration monitoring apparatus 100.

[0053] In one embodiment of the invention, the analysis unit 104 evaluates the data or information from the sensor(s) or contact point(s) of the sensor(s) and determines the level of hydration of an individual. In another embodiment of the invention, the analysis unit 104 evaluates and/or accounts for the rebounding effect of drinking fluid or otherwise hydrating during a monitored period. If an individual drinks during a period of monitoring, such as drinking a sports drink during a workout session or eating soup when sick, there may be a rebounding period where the water level, sweat level, sodium level, electrolyte level, or other levels of the an individual will increase, decrease, or otherwise change. The sensor(s), contact point(s) of the sensor(s), and/or sensor interface 200 may detect such rehydration or rebounding effect and the sensor (s), contact point(s) of the sensor(s), sensor interface 300, and/or analysis unit 104 may take the rehydration or rebounding effect into account in determining the various bodily level(s) of an individual.

[0054] In one embodiment of the invention, the sensor interface 300 or data acquisition unit 102 supplies the alternating current at a single frequency. Alternatively, the sensor interface 300 or data acquisition unit 102 supplies a plurality of currents at defined frequencies to the individual. In another embodiment of the invention, the sensor interface 300 or data acquisition unit 102 supplies an alternating current across a frequency spectrum or frequency range.

[0055] In one embodiment of the invention, an impedance sensor 302 is connected to the sensor interface 300 and is attached to the individual's body. The impedance sensor 302 can be used to measure the overall amount or the change in the overall amount of fluid, water, sweat, electrolytes, or sodium contained by an individual's body. Alternatively, the impedance sensor 302 can measure the overall amount or the change in the amount of fluid, water, sweat, electrolytes, or sodium contained within an individual's cells. Alternatively, the impedance sensor 302 can measure the overall amount or change in the amount of fluid, water, sweat, electrolytes, or sodium on the surface of an individual's skin or body. In one embodiment of the invention, the impedance sensor 302 measures the change in the sweat rate of the body of an individual or the rate at which an individual is excreting water, sweat, or sodium from his body or cells. A bio-impedance measurement may also indicate changes in the body and/or skin temperature of an individual. Thus, the monitoring of an individual's impedance levels will indicate the individual's level of hydration and if they are becoming dehydrated. In one embodiment, at least one impedance sensor 302 measures an impedance or bio-impedance value for an individual or measures multiple impedance or bio-impedance values collected from the individual. In one embodiment of the invention, the impedance sensor 302 measures the impedance or bio-impedance of an individual by running an electrical current through the body of an individual or along the body or skin surface of an individual using a plurality of sensors or contact points of the sensors. In one embodiment of the invention, the impedance sensor 302 measures the impedance over a specified or continuous frequency range or spectrum. In one embodiment of the invention, the impedance sensor 302, analysis unit 104, and/or the sensor interface 300 accounts and/or adjusts the data or information variance or change in the impedance

sensor data based on the effect of a the change in the electrolyte, sodium, water, bodily fluid, or fat of the body of an individual or on the skin surface of an individual. Alternatively, the impedance sensor **302** measures the impedance or bio-impedance using an optical device, spectrometer **308**, or ultrasonic sensor **308**.

[0056] In one embodiment of the invention, the analysis unit **104** receives the impedance or bio-impedance data collected by the impedance sensor **302** and sensor interface **300** and compares the impedance or bio-impedance values with a predetermined or defined value. Alternatively, the analysis unit **104** may analyze the variance or change or the current or real-time impedance or bio-impedance values with previously collected values that are stored in a non-transitory computer readable memory.

[0057] In another embodiment of the invention, a temperature sensor **304** is connected to the sensor interface **300**. In one embodiment of the invention, the temperature sensor **304** measures the body temperature of the individual. Alternatively, the temperature sensor **304** measures the skin temperature of an individual. Alternatively, the temperature sensor **304** measures the ambient temperature of the area approximate or surrounding an individual. In one embodiment of the invention, the temperature sensor **304** measures the body and/or skin temperature of an individual using a thermostat, thermal-couple, and/or thermistor that is in contact with the body and/or skin of an individual. In another embodiment of the invention, the temperature sensor **304** measures the ambient temperature of an area approximate an individual using a thermostat. Alternatively, the temperature sensor **304** measures the temperature using an optical device, bio-impedance, thermal imaging, or spectroscopy.

[0058] In a further embodiment of the invention, a humidity sensor **310** is connected to the sensor interface **300**. The humidity sensor **310** measures the absolute or relative level of humidity of the area approximate an individual for a defined period, point in time, or multiple points in time. Alternatively, the humidity sensor **310** measures the absolute or relative level of humidity approximate an individual over a period of time.

[0059] In a further embodiment of the invention, a heart rate sensor **312** is connected to the sensor interface **106**. The heart rate sensor **312** measures the number of beats of an individual's heart over a defined period of time, i.e. the heart rate. The heart rate sensor **312** may detect the number of beats of a heart by sensing the electrical signal transmitted by the heart. Alternatively, the heart rate sensor **312** may detect the number of beats of a heart by using an optical device, bio-impedance, or spectroscopy.

[0060] In a further embodiment of the invention, a sodium level sensor is connected to the sensor interface **106**. The sodium level sensor measures the amount of sodium or salt secreted or excreted by an individual over a period of time. Alternatively, the sodium level sensor may measure the sodium or salt amount contained within the cells of an individual or on the surface of the skin of an individual using an optical device, bio-impedance, or spectroscopy. The sodium level sensor may measure the absolute or relative amount of sodium or salt at a defined time or over a defined period of time.

[0061] In a further embodiment of the invention, a viscosity sensor **306** is connected to the sensor interface **300**. In one embodiment the viscosity sensor **306** measures the skin viscosity of an individual. Alternatively, the viscosity sensor **306**

measures the blood viscosity of an individual. The blood viscosity increases, i.e. the blood becomes thicker, as an individual becomes increasingly dehydrated, and thus the blood flow of an individual decreases. The skin viscosity increases, i.e. the skin becomes less elastic, as an individual becomes increasingly dehydrated. In one embodiment of the invention, the viscosity measuring apparatus may measure the skin or blood viscosity of the individual using an optical device, Doppler sensor, bio-impedance, spectroscopy, or a heart rate sensor.

[0062] In a further embodiment of the invention, a dietary intake sensor **314** is connected to the sensor interface **300**. In one embodiment of the invention, the dietary intake sensor **314** measures the amount of fluid or food an individual intakes into their body. As an individual's dietary intake level varies, the individual's hydration level may also vary. If an individual's fluid intake increases over a period of time it may increase the period of time before an individual becomes dehydrated or feels the effect of dehydration. Similarly, if an individual's fluid intake decreases over a period of time it may decrease the period of time for the individual to become dehydrated or feel the effects of dehydration. The diet habits of an individual may also affect the hydration level and hydration retention level of an individual. For example, as an individual intakes more sodium or fat the individual's body may retain more fluid or water. The individual's dietary intake may be measured in a variety of ways. In one embodiment, an individual's dietary intake is manually entered by the individual using an interface such as a computer, cellular phone, or keyboard. Alternatively, an individual's dietary intake may be measured automatically with a sensor in a fluid or food container, an optical device, bio-impedance, spectroscopy, or a sensor embedded or implanted within the individual's body such as the mouth.

[0063] In a further embodiment of the invention, an activity level sensor is connected to the sensor interface **300**. In one embodiment of the invention, the activity level sensor measures the amount of activity an individual engages in over a given period of time. As an individual increases their exertion levels over a period of time, the individual may excrete an increased amount of sweat, water, or fluid and thereby lower their hydration or fluid level. Similarly, if an individual decreases their activity or exertion level over a period of time, the individual may excrete almost zero sweat, water, or fluid or a decreased amount of sweat, water, or fluid and thereby remain hydrated for a longer period of time. The activity level sensor may be measured in a variety of ways. In one embodiment of the invention, the activity level sensor utilizes a gyroscope or pedometer for measure the amount of movement or activity by an individual. Alternatively, the activity level sensor may utilize a GPS unit to monitor the movement, speed, or distance traveled by the individual to measure the individual's activity level. Alternatively, the altitude of an individual or the change in altitude may affect the amount of effort or energy expended in order to perform an activity. In one embodiment of the invention, the activity level sensor may utilize an altimeter to at least partially measure an individual's activity level. Alternatively, the activity level sensor may utilize an optical device, bio-impedance, spectroscopy, or heart rate monitor to measure the individual's activity level.

[0064] The sensor interface **300** communicates the measurements taken by one or more attached sensors, contact point(s) of the sensors, and/or sensing or measuring appara-

tuses attached to the sensor interface 300 to the data acquisition unit 200. The data acquisition unit 200 communicates the measurement data or information collected by the sensors, contact point(s) of the sensors, and/or sensing or measuring apparatuses attached to or in communication with the analysis unit 200. The analysis unit 200 evaluates the one or more measurements from the one or more sensors, contact point(s) of the sensors, and/or sensing or measuring apparatuses and bases a hydration analysis at least in part on the data and information from the one or more sensors and sensing or measuring apparatuses.

[0065] FIG. 4 depicts one embodiment of a sweatband 400 with a sensor or array of sensors that is connected to the sensor interface. In one embodiment the sensor array may be attached or embedded in a device such as a headband, armband, sweatband, chest band, wrist band, leg band. The sensor array may include, but is not limited to, at least one of the following sensors and interfaces: an impedance sensor 302, a temperature sensor 304, a viscosity sensor 306, spectrometer or ultrasonic sensor 308, a humidity sensor 310, a heart rate sensor 312, a dietary intake sensor 314, an activity sensor, a communication interface, a data input/output interface, a sodium level sensor, and/or a fluid intake sensor. The sensor(s) 402 and/or the contact point(s) 406 of the sensors in the sensor interface 300 may be in contact with the surface or otherwise non-invasively in contact with an individual, such as a contact on the skin surface, eyes, fingernails, or hair of the individual. Alternatively, the sensor(s) 402 and/or the contact point(s) 406 of the sensors in the sensor interface may be in invasive contact with an individual. FIG. 4 depicts one embodiment of the invention where the sensor(s) 402 or contact point(s) of the sensor(s) 406 are attached on the interior or inner radius of the device. FIG. 4 also depicts a sensor array where the sensor(s) 412 or contact point(s) of the sensor(s) 414 are attached on the exterior surface or outer radius of the device and are not in contact or noninvasively in contact with an individual. The sensor(s) 402 and 412 or contact point(s) of the sensor(s) 406 and 414 of sensor arrays of FIG. 4 may or may not be in contact with the skin of an individual or may comprise a combination of the sensors with at least one sensor 402 or contact point 406 of the sensors in contact with the skin and at least one sensor 412 or contact point 414 of the sensors not in contact with the skin of the individual. FIG. 4 also depict that the sensor interface 300 may comprise a display device 404 for presenting information or sending an alert to an individual. In one embodiment of the invention, FIG. 4 depicts a plurality of sensors 412 that run an electrical current 410 between the plurality of sensors 412 to take measurements. Alternatively, a plurality of contact points 414 may run an electrical current between the plurality of contact points 414 to take measurements.

[0066] FIGS. 5a, 5b, and 5c depicts a plurality of positions on the individual's body that the sensor interface 300, sensor(s), and/or contact point(s) of the sensors, or the hydration monitoring apparatus 100 may be attached to the individual. The hydration monitoring apparatus 100 may be attached to the individual's head using a headband, to the individual's chest using a chest band, to the individual's arm or wrist using an armband, to the individual's ankle using an ankle band, or otherwise attached to an individual's body using a sweatband, bandage, band, watch, bracelet, ring, adherent, or other attachments and connections. FIG. 5a depicts the hydration monitoring apparatus 100 attached to the foot or ankle 500 of an individual. FIG. 5b depicts the hydration monitoring appa-

ratus 100 attached to the arm or wrist 502 of an individual. FIG. 5c depicts the hydration monitoring apparatus 100 attached to the head 504 of an individual. The sensor interface 300, sensor(s), and/or contact point(s) of the sensors, or the hydration monitoring apparatus 100, and/or sensor array may alternatively be attached to the individual by integrating it into the apparel or garments of the individual or by otherwise attaching it to the individual.

[0067] FIG. 6 depicts one embodiment of the process 600 employed by the hydration monitoring apparatus 100. In step 602, the hydration monitoring apparatus 100 is powered on. In step 604, the hydration monitoring apparatus 100 is initialized and/or calibrated. In step 606, a time reference of the time reference unit 218, such as a clock or timer is set. In step 608, the personalized settings of the individual are input and/or set. In step 610, the hydration monitoring apparatus 100 monitors the sensors attached to the sensor interface 106. In step 612, the analysis unit analyzes the data or information received from sensors, units, devices, and/or interfaces in communication with the data acquisition unit 102. In step 614, the data logger 210 of the data acquisition unit 200 stores the acquired data and information. In step 616, the results of the acquired data and information and the analyzed data and information are displayed. In step 618, the hydration monitoring apparatus 100 is powered off.

[0068] FIG. 7 depicts one embodiment of the process 700 employed by the data acquisition unit 102. In step 702, the data acquisition unit 102 monitors the units and interfaces that are in communication with it or attached to it. In step 704, the data acquisition unit 102 acquires data from the sensors or contact point of the sensors of the sensor interface 106. In step 706, the analysis unit evaluates the real time data and information and/or the data and information acquired and/or stored in the data logger 210 of the data acquisition unit 200. In step 706, the analysis unit may also determine if there is a variance or change in the acquired, present, real-time, and/or previously acquired data. In step 708, the hydration monitoring apparatus 100 displays the acquired, present, or real-time data and information and/or the results of the analyzed data. Alternatively, in step 708, the hydration monitoring apparatus 100 may alert the individual or a third party regarding the acquired, present, real-time, and/or previously acquired data and information and/or the results of the analyzed data.

[0069] A typical set of impedance readings is presented in FIG. 8a for a normally hydrated individual that excreting sweat during a period of activity. As the individual begins to sweat the impedance reading begins to decrease. As the individual continues to exert himself over time the individual will increasingly excrete more sweat until they reach a peak rate of sweating. The normally hydrated individual will continue to sweat at that peak rate of sweating until they decrease the level of exertion for the activity or stop the exertion activity.

[0070] A set of bio-impedance readings is presented in FIG. 8b for an individual becoming dehydrated due to excreting sweat during a defined period of activity. As the individual begins to sweat the impedance reading begins to decrease. As the individual continues to exert himself over the defined period of time, the individual will increasingly excrete more sweat until they reach a peak rate of sweating. However, as the individual becomes dehydrated he will continue to exert himself at the same approximate level but will excrete less sweat because the body fluid or sweat level is lowered and his body is unable to continue to excrete sweat at the peak rate of sweat. The dehydrated individual will continue to excrete less sweat

as he continues to exert himself during the activity and thus the measured impedance reading will increase in ohms as the individual becomes more dehydrated.

[0071] Various operations of embodiments are provided herein. In one embodiment, one or more of the operations described may constitute computer readable instructions stored on one or more non-transitory computer readable media, which if executed by a computing device, will cause the computing device to perform the operations described. The order in which some or all of the operations are described should not be construed as to imply that these operations are necessarily order dependent. Alternative ordering will be appreciated by one skilled in the art having the benefit of this description. Further, it will be understood that not all operations are necessarily present in each embodiment provided herein.

[0072] Although the individual matter has been described in language specific to structural features and/or methodological acts, it is to be understood that the individual matter defined in the appended claims is not necessarily limited to the specific features or acts described above. Rather, the specific features and acts described above are disclosed as example forms of implementing the claims.

[0073] As used in this application, the terms “device,” “unit,” “system,” “interface”, and the like are generally intended to refer to a computer-related entity, either hardware, a combination of hardware and software, software, or software in execution. For example, a component may be, but is not limited to being, a process running on a processor, a processor, an object, an executable, a thread of execution, a program, and/or a computer. By way of illustration, both an application running on a controller and the controller can be a component. One or more components may reside within a process and/or thread of execution and a component may be localized on one computer and/or distributed between two or more computers.

[0074] Furthermore, the claimed individual matter may be implemented as a method, apparatus, or article of manufacture using standard programming and/or engineering techniques to produce software, firmware, hardware, or any combination thereof to control a computer to implement the disclosed individual matter.

[0075] Also, although the disclosure has been shown and described with respect to one or more implementations, equivalent alterations and modifications will occur to others skilled in the art based upon a reading and understanding of this specification and the annexed drawings. The disclosure includes all such modifications and alterations and is limited only by the scope of the following claims. In particular regard to the various functions performed by the above described components (e.g., elements, resources, etc.), the terms used to describe such components are intended to correspond, unless otherwise indicated, to any component which performs the specified function of the described component (e.g., that is functionally equivalent), even though not structurally equivalent to the disclosed structure which performs the function in the herein illustrated exemplary implementations of the disclosure. In addition, while a particular feature of the disclosure may have been disclosed with respect to only one of several implementations, such feature may be combined with one or more other features of the other implementations as may be desired and advantageous for any given or particular application. Furthermore, to the extent that the terms “includes”, “having”, “has”, “with”, or variants thereof are

used in either the detailed description or the claims, such terms are intended to be inclusive in a manner similar to the term “comprising.”

What is claimed is:

1. A hydration monitoring apparatus comprising:
 - at least one sensor;
 - an analysis unit;
 - wherein the at least one sensor acquires at least one biological measurement of an individual;
 - wherein the analysis unit receives the at least one biological signal from the sensor; and
 - wherein the analysis unit uses a processor to analyze the hydration condition of the individual.
2. A hydration monitoring device comprising:
 - at least one sensor;
 - a sensor interface;
 - a data acquisition unit;
 - an analysis unit;
 - wherein the at least one sensor acquires at least one biological signal of an individual;
 - wherein the sensor interface receives the at least one biological signal from the at least one sensor;
 - wherein the data acquisition unit receives and stores the at least one biological signal from the sensor interface as biological data on a non-transitory computer readable medium; and
 - wherein the data analysis unit receives the biological data from the data acquisition unit uses a processor to analyze the hydration condition of the individual based on variance of the stored at least one biological signal.
3. A method of determining the hydration level of a user, the method comprising:
 - collecting at least one biological measurement using at least one sensor;
 - determining the hydration level of the user based on the at least one biological measurement from the at least one sensor; and
 - wherein the hydration level of the user is determined using a multi-variant analysis.
4. The method of claim 3, wherein the method further comprises collecting at least one environmental measurement using at least one sensor.
5. The method of claim 5, wherein the hydration level is determined using a multi-variant analysis of the at least one environmental measurement and the at least one biological measurement.
6. The method of claim 3, wherein at least one biological measurement is collected using at least one of the sensors: an impedance sensor, a temperature sensor, a viscosity sensor, a spectrometer, an ultrasonic sensor, a heart rate sensor, a dietary intake sensor, an activity sensor, a sodium level sensor, and a fluid intake sensor.
7. The method of claim 3, wherein at least one environmental measurement is collected using at least one of the sensors: an impedance sensor, a temperature sensor, a spectrometer, an ultrasonic sensor, a humidity sensor, and an activity sensor.
8. The method of claim 3, wherein the at least one sensor collects the at least one biological measurement in real-time.
9. The method of claim 4, wherein one or more of the at least one biological measurement and the environmental measurement are stored in a non-transitory computer readable medium.

10. The method of claim **9**, wherein the hydration level of the user is determined based on a multi-variant analysis of one or more of the at least one biological measurement and the at least one environmental measurement are stored in a non-transitory computer readable medium.

11. The method of claim **9**, wherein the hydration level of the user is determined based on change between the stored one or more of the at least one biological measurement and the at least one environmental measurement and a real-time measurement of one or more of the at least one biological measurement and the at least one environmental measurement.

12. The method of claim **3**, wherein the hydration level of the user is determined based on the change in the at least one biological measurement.

13. The method of claim **3**, wherein at least one biological measurement is collected using an impedance sensor that takes an impedance measurement of a continuous frequency spectrum.

14. The method of claim **3**, wherein at least one biological measurement is collected using an impedance sensor that measures the transfer of fluid from at least one area of the user to another area of the user.

15. The method of claim **3**, further comprising determining the relative change in the at least one biological measurement.

16. The method of claim **3**, further comprising determining if the user is dehydrated based on the hydration level of the user.

17. The method of claim **3**, wherein at least one biological measurement is collected non-invasively.

18. The method of claim **3**, further comprising determining if the user is dehydrated based on the relative change in the hydration level of the user.

19. The method of claim **9**, wherein the hydration level of the user is determined based on a partial least squaring analysis of one or more of the at least one biological measurement and the at least one environmental measurement are stored in a non-transitory computer readable medium.

20. The hydration monitoring apparatus of claim **1**, where in the apparatus is a headband, armband, sweatband, chest band, wrist band, or leg band.

* * * * *

专利名称(译)	水化监测仪器		
公开(公告)号	US20140221792A1	公开(公告)日	2014-08-07
申请号	US13/756742	申请日	2013-02-01
[标]申请(专利权)人(译)	MILLER DEVIN WARNER DAVID MILLER RICH		
申请(专利权)人(译)	MILLER , DEVIN WARNER MILLER , DAVID RICH		
当前申请(专利权)人(译)	MILLER , DEVIN WARNER MILLER , DAVID RICH		
[标]发明人	MILLER DEVIN WARNER MILLER DAVID RICH		
发明人	MILLER, DEVIN WARNER MILLER, DAVID RICH		
IPC分类号	A61B5/053 A61B5/00 A61B5/11 A61B5/024 A61B5/145 A61B5/01 A61B8/00		
CPC分类号	A61B5/0537 A61B5/0075 A61B5/01 A61B8/00 A61B5/1118 A61B5/14546 A61B5/6801 A61B5/024 A61B5/4875		
其他公开文献	US10463273		
外部链接	Espacenet USPTO		

摘要(译)

公开了一种水合监测装置。水合监测装置包括至少一个传感器和分析单元。水合监测装置可以对个体进行至少一种生物测定，生物测定和/或生理测量，并测量个体的水合程度，脱水水平或状态或体液水平。水合监测装置基于一种或多种生物测量，生物和/或生理测量指示个体的水合水平，脱水水平或状态或体液水平。在本发明的一个实施例中，水合监测装置确定是否通知使用者他们的水合程度，脱水水平或状态，或体液水平。在一个实施例中，水合监测装置还包括通知装置，该通知装置通知个体该个体正在接近脱水。

