



US009949687B2

(12) **United States Patent**
Kalgren et al.

(10) **Patent No.:** **US 9,949,687 B2**
(45) **Date of Patent:** ***Apr. 24, 2018**

(54) **SYSTEM AND METHOD FOR CORRELATION OF PATIENT HEALTH INFORMATION AND DEVICE DATA**

(71) Applicant: **Cardiac Pacemakers, Inc.**, St. Paul, MN (US)

(72) Inventors: **James R. Kalgren**, Lino Lakes, MN (US); **Rene H. Wentkowski**, Berlin (DE); **Jeffrey E. Stahmann**, Ramsey, MN (US)

(73) Assignee: **Cardiac Pacemakers, Inc.**, St. Paul, MN (US)

(*) Notice: Subject to any disclaimer, the term of this patent is extended or adjusted under 35 U.S.C. 154(b) by 0 days.

This patent is subject to a terminal disclaimer.

(21) Appl. No.: **15/387,009**

(22) Filed: **Dec. 21, 2016**

(65) **Prior Publication Data**
US 2017/0100074 A1 Apr. 13, 2017

Related U.S. Application Data
(63) Continuation of application No. 14/879,724, filed on Oct. 9, 2015, now Pat. No. 9,533,166, which is a (Continued)

(51) **Int. Cl.**
A61N 1/00 (2006.01)
A61B 5/00 (2006.01)
(Continued)

(52) **U.S. Cl.**
CPC **A61B 5/4848** (2013.01); **A61B 5/0006** (2013.01); **A61B 5/0022** (2013.01);
(Continued)

(58) **Field of Classification Search**
CPC A61B 5/0006; A61B 5/0022; A61B 5/044; A61B 5/1118; A61B 5/4848; A61B 5/7246; A61B 5/742; A61N 1/3702; A61N 1/3956

See application file for complete search history.

(56) **References Cited**
U.S. PATENT DOCUMENTS

4,006,737 A 2/1977 Cherry et al.
4,090,505 A 5/1978 Mortara
(Continued)

FOREIGN PATENT DOCUMENTS

EP 0491649 6/1992
EP 0558353 9/1993
(Continued)

OTHER PUBLICATIONS

"U.S. Appl. No. 09/372,157, Non-Final Office Action dated Apr. 25, 2001," 9 pgs.
(Continued)

Primary Examiner — George Manuel
(74) *Attorney, Agent, or Firm* — Pauly, DeVries Smith & Deffner LLC

(57) **ABSTRACT**

A system and method for correlating health related data for display. The system includes a medical device recording data and a display producing device which correlates the data and simultaneously displays different types of data or displays two sets of the same type of data along with the circumstances at which the two sets of data were recorded. Such displays aid a physician in prescribing and ascertaining the efficacy of cardiac therapies.

20 Claims, 9 Drawing Sheets

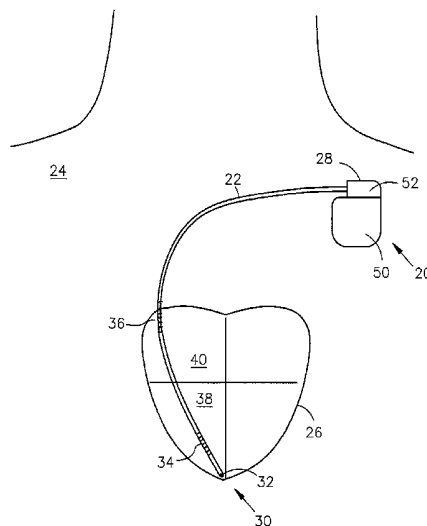

Related U.S. Application Data

continuation of application No. 14/480,962, filed on Sep. 9, 2014, now Pat. No. 9,155,904, which is a continuation of application No. 13/964,893, filed on Aug. 12, 2013, now Pat. No. 8,838,220, which is a continuation of application No. 13/411,063, filed on Mar. 2, 2012, now Pat. No. 8,548,576, which is a continuation of application No. 12/941,377, filed on Nov. 8, 2010, now Pat. No. 8,131,351, which is a continuation of application No. 11/379,912, filed on Apr. 24, 2006, now Pat. No. 7,844,322, which is a continuation of application No. 10/687,433, filed on Oct. 16, 2003, now Pat. No. 7,047,065, which is a continuation of application No. 09/738,869, filed on Dec. 15, 2000, now Pat. No. 6,665,558.

(51) **Int. Cl.***A61B 5/044* (2006.01)*A61B 5/11* (2006.01)*A61N 1/37* (2006.01)*A61N 1/39* (2006.01)(52) **U.S. Cl.**

CPC *A61B 5/044* (2013.01); *A61B 5/118* (2013.01); *A61B 5/7246* (2013.01); *A61B 5/742* (2013.01); *A61N 1/3702* (2013.01); *A61N 1/3956* (2013.01)

(56)

References Cited

U.S. PATENT DOCUMENTS

4,166,470 A	9/1979	Neumann	5,129,392 A	7/1992	Bardy et al.
4,172,459 A	10/1979	Hepp	5,184,614 A	2/1993	Collins et al.
4,187,854 A	2/1980	Citron et al.	5,193,550 A	3/1993	Duffin et al.
4,197,850 A	4/1980	Schulman et al.	5,209,228 A	5/1993	Cano et al.
4,223,678 A	9/1980	Langer et al.	5,213,098 A	5/1993	Bennett et al.
4,232,679 A	11/1980	Schulman	5,215,083 A	6/1993	Drane et al.
4,236,524 A	12/1980	Powell et al.	5,217,021 A	6/1993	Steinhaus et al.
4,316,249 A	2/1982	Gallant et al.	5,224,475 A	7/1993	Berg et al.
4,336,810 A	6/1982	Anderson et al.	5,273,049 A	12/1993	Steinhaus et al.
4,364,697 A	12/1982	Binns et al.	5,279,293 A	1/1994	Andersen et al.
4,407,288 A	10/1983	Langer et al.	5,292,341 A	3/1994	Snell et al.
4,509,530 A	4/1985	Curtis et al.	5,299,118 A	3/1994	Martens et al.
4,527,567 A	7/1985	Fischler et al.	5,309,919 A	5/1994	Snell et al.
4,529,401 A	7/1985	Leslie et al.	5,311,873 A	5/1994	Savard et al.
4,531,527 A	7/1985	Reinhold, Jr. et al.	5,311,874 A	5/1994	Baumann et al.
4,549,552 A	10/1985	Groch et al.	5,312,441 A	5/1994	Mader et al.
4,596,255 A	6/1986	Snell et al.	5,315,512 A	5/1994	Roth
4,601,291 A	7/1986	Boute et al.	5,341,811 A	8/1994	Cano et al.
4,680,708 A	7/1987	Ambos et al.	5,342,402 A	8/1994	Olson et al.
4,791,936 A	12/1988	Snell et al.	5,344,430 A	9/1994	Berg et al.
4,800,883 A	1/1989	Winstrom et al.	5,357,969 A	10/1994	Herleikson et al.
4,802,491 A	2/1989	Cohen et al.	5,391,188 A	2/1995	Nelson et al.
4,809,697 A	3/1989	Causey, III et al.	5,402,794 A	4/1995	Wahlstrand et al.
4,825,869 A	5/1989	Sasmor et al.	5,404,877 A	4/1995	Nolan et al.
4,850,357 A	7/1989	Bach et al.	5,404,880 A	4/1995	Throne
4,944,298 A	7/1990	Sholder et al.	5,411,530 A	5/1995	Akhtar et al.
4,947,857 A	8/1990	Albert et al.	5,413,594 A	5/1995	Williams
4,958,632 A	9/1990	Duggan	5,417,714 A	5/1995	Levine et al.
4,964,410 A	10/1990	Leahy et al.	5,421,830 A	6/1995	Epstein et al.
4,974,598 A	12/1990	John	5,423,871 A	6/1995	Hoegnelid et al.
4,979,506 A	12/1990	Silvian et al.	5,431,692 A	7/1995	Hansen et al.
4,989,610 A	2/1991	Sundahl et al.	5,458,623 A	10/1995	Lu et al.
4,998,531 A	3/1991	Bocchi et al.	5,464,433 A	11/1995	White et al.
5,000,189 A	3/1991	Throne et al.	5,476,485 A	12/1995	Weinberg et al.
5,012,814 A	5/1991	Mills et al.	5,487,754 A	1/1996	Snell et al.
5,027,824 A	7/1991	Dougherty et al.	5,487,755 A	1/1996	Snell et al.
5,046,504 A	9/1991	Albert et al.	5,496,351 A	3/1996	Plicchi et al.
5,047,930 A	9/1991	Martens et al.	5,507,786 A	4/1996	Morgan et al.
5,050,612 A	9/1991	Matsumura	5,511,553 A	4/1996	Segalowitz
5,052,395 A	10/1991	Burton et al.	5,513,645 A	5/1996	Jacobson et al.
5,111,816 A	5/1992	Pless et al.	5,535,753 A	7/1996	Petrucelli et al.
5,113,869 A	5/1992	Nappholz et al.	5,549,646 A	8/1996	Katz et al.
			5,549,654 A	8/1996	Powell
			5,555,888 A	9/1996	Brewer et al.
			5,578,063 A	11/1996	Bocek et al.
			5,584,298 A	12/1996	Kabal
			5,586,556 A	12/1996	Spivey et al.
			5,591,214 A	1/1997	Lu
			5,603,331 A	2/1997	Heemels et al.
			5,607,460 A	3/1997	Kroll et al.
			5,609,612 A	3/1997	Plicchi et al.
			5,609,615 A	3/1997	Sanders et al.
			5,613,495 A	3/1997	Mills et al.
			5,620,474 A	4/1997	Koopman et al.
			5,622,178 A	4/1997	Gilham et al.
			5,626,620 A	5/1997	Kieval et al.
			5,626,623 A	5/1997	Kieval et al.
			5,628,321 A	5/1997	Scheib et al.
			5,628,776 A	5/1997	Paul et al.
			5,643,255 A	7/1997	Organ
			5,647,369 A	7/1997	Petrucelli et al.
			5,653,737 A	8/1997	Van Lake et al.
			5,674,249 A	10/1997	De Coriolis et al.
			5,683,431 A	11/1997	Wang et al.
			5,687,737 A	11/1997	Branham et al.
			5,693,075 A	12/1997	Plicchi et al.
			5,697,959 A	12/1997	Poore
			5,709,712 A	1/1998	Paul et al.
			5,713,366 A	2/1998	Armstrong et al.
			5,716,383 A	2/1998	Kieval et al.
			5,716,384 A	2/1998	Snell
			5,722,999 A	3/1998	Snell
			5,724,985 A	3/1998	Snell et al.
			5,732,708 A	3/1998	Nau et al.
			5,743,268 A	4/1998	Kabal
			5,749,900 A	5/1998	Schroepffel et al.
			5,749,906 A	5/1998	Kieval et al.
			5,749,907 A	5/1998	Mann
			5,755,742 A	5/1998	Schuelke et al.

(56)

References Cited

U.S. PATENT DOCUMENTS

5,759,196 A 6/1998 Hess et al.
 5,759,199 A 6/1998 Snell et al.
 5,772,604 A 6/1998 Langberg et al.
 5,782,890 A 7/1998 Wahlstrand et al.
 5,788,640 A 8/1998 Peters
 5,792,203 A 8/1998 Schroepfel et al.
 5,792,204 A 8/1998 Snell et al.
 5,792,207 A 8/1998 Dietrich
 5,814,083 A 9/1998 Hess et al.
 5,814,088 A 9/1998 Paul et al.
 5,817,137 A 10/1998 Kaemmerer et al.
 5,833,623 A 11/1998 Mann et al.
 5,876,353 A 3/1999 Riff
 5,891,043 A 4/1999 Ericksen et al.
 5,891,178 A 4/1999 Mann et al.
 5,891,179 A 4/1999 Er et al.
 5,897,577 A 4/1999 Cinbis et al.
 5,924,989 A 7/1999 Polz et al.
 5,925,067 A 7/1999 Lu et al.
 5,948,005 A 9/1999 Valikai et al.
 5,951,484 A 9/1999 Hoitum et al.
 5,954,664 A 9/1999 Seegobin
 5,957,861 A 9/1999 Combs et al.
 5,961,467 A 10/1999 Shimazu et al.
 5,974,341 A 10/1999 Er et al.
 5,978,707 A 11/1999 Krig et al.
 6,004,276 A 12/1999 Wright et al.
 6,007,493 A 12/1999 Ericksen et al.
 6,016,442 A 1/2000 Hsu et al.
 6,016,446 A 1/2000 Belalcazar
 6,016,447 A 1/2000 Juran et al.
 6,016,448 A 1/2000 Busacker et al.
 6,017,307 A 1/2000 Raines
 6,035,233 A 3/2000 Schroepfel et al.
 6,050,950 A 4/2000 Mohler
 6,067,471 A 5/2000 Warren
 6,076,015 A 6/2000 Hartley et al.
 6,091,990 A 7/2000 Hsu et al.
 6,095,984 A 8/2000 Amano et al.
 6,101,415 A 8/2000 Er et al.
 6,108,577 A 8/2000 Benser et al.
 6,112,117 A 8/2000 Kenknight et al.
 6,122,536 A 9/2000 Sun et al.
 6,240,317 B1 5/2001 Villaseca et al.
 6,243,606 B1 6/2001 Mann et al.
 6,253,102 B1 6/2001 Hsu et al.
 6,263,244 B1 7/2001 Mann et al.
 6,264,614 B1 7/2001 Albert et al.
 6,289,244 B1 9/2001 Conley et al.
 6,289,248 B1 9/2001 Conley et al.
 6,301,503 B1 10/2001 Hsu et al.
 6,308,095 B1 10/2001 Hsu et al.
 6,311,089 B1 10/2001 Mann et al.
 6,312,378 B1 11/2001 Bardy
 6,345,200 B1 2/2002 Mouchawar et al.
 6,415,175 B1 7/2002 Conley et al.
 6,418,340 B1 7/2002 Conley et al.
 6,438,407 B1 8/2002 Ousdigian et al.
 6,449,504 B1 9/2002 Conley et al.
 6,459,929 B1 10/2002 Hopper et al.
 6,459,934 B1 10/2002 Kadhiresan et al.
 6,477,404 B1 11/2002 Yonce et al.
 6,535,763 B1 3/2003 Hiebert et al.
 6,580,948 B2 6/2003 Haupt et al.
 6,665,558 B2 12/2003 Kalgren et al.
 6,718,198 B2 4/2004 Conley et al.
 6,721,594 B2 4/2004 Conley et al.
 6,843,801 B2 1/2005 Conley et al.
 6,941,167 B2 9/2005 Stahmann et al.
 7,047,065 B2 5/2006 Kalgren et al.
 7,117,037 B2 10/2006 Hiebert et al.
 7,406,348 B2 7/2008 Stahmann et al.
 7,418,295 B2 8/2008 Conley et al.
 7,844,322 B2 11/2010 Kalgren et al.
 7,962,203 B2 6/2011 Conley et al.

8,032,208 B2 10/2011 Stahmann et al.
 8,131,351 B2 3/2012 Kalgren et al.
 8,463,369 B2 6/2013 Conley et al.
 8,548,576 B2 10/2013 Stahmann et al.
 8,725,242 B2 5/2014 Stahmann et al.
 8,838,220 B2 9/2014 Stahmann et al.
 9,155,904 B2 10/2015 Kalgren et al.
 9,533,166 B2 1/2017 Kalgren et al.
 2002/0019586 A1 2/2002 Teller et al.
 2002/0042563 A1 4/2002 Becerra et al.
 2002/0077562 A1 6/2002 Kalgren et al.
 2002/0077859 A1 6/2002 Stahmann et al.
 2002/0151809 A1 10/2002 Conley et al.
 2003/0114891 A1 6/2003 Hiebert et al.
 2004/0082976 A1 4/2004 Kalgren et al.
 2005/0107840 A1 5/2005 Conley et al.
 2005/0187588 A1 8/2005 Stahmann et al.
 2006/0189877 A1 8/2006 Kalgren et al.
 2008/0269827 A1 10/2008 Stahmann et al.
 2009/0036942 A1 2/2009 Conley et al.
 2011/0046692 A1 2/2011 Kalgren et al.
 2011/0238127 A1 9/2011 Conley et al.
 2012/0016250 A1 1/2012 Stahmann et al.
 2012/0165883 A1 6/2012 Kalgren et al.
 2013/0324862 A1 12/2013 Kalgren et al.
 2015/0005835 A1 1/2015 Kalgren et al.
 2016/0030759 A1 2/2016 Kalgren et al.

FOREIGN PATENT DOCUMENTS

EP 0711531 5/1996
 EP 0850661 7/1998
 WO 9927992 6/1999

OTHER PUBLICATIONS

"U.S. Appl. No. 09/372,157, Notice of Allowance dated Feb. 12, 2002," 5 pgs.
 "U.S. Appl. No. 09/372,157, Notice of Allowance dated Sep. 7, 2001," 6 pgs.
 "U.S. Appl. No. 09/372,157, Request for Continued Examination filed Dec. 7, 2001," 8 pgs.
 "U.S. Appl. No. 09/372,157, Response filed Mar. 20, 2001 to Restriction Requirement dated Feb. 20, 2001," 1 pg.
 "U.S. Appl. No. 09/372,157, Response filed Jul. 25, 2001 to Non-Final Office Action dated Apr. 25, 2001," 13 pgs.
 "U.S. Appl. No. 09/372,157, Restriction Requirement dated Feb. 20, 2001," 4 pgs.
 "U.S. Appl. No. 09/378,030, Restriction Requirement dated May 9, 2001," 4 pgs.
 "U.S. Appl. No. 09/378,406, Non Final Office Action dated Apr. 27, 2001," 6 pgs.
 "U.S. Appl. No. 09/378,406, Notice of Allowance dated Feb. 12, 2002," 6 pgs.
 "U.S. Appl. No. 09/378,406, Notice of Allowance dated Aug. 23, 2001," 6 pgs.
 "U.S. Appl. No. 09/378,406, Response filed Jul. 27, 2001 to Non-Final Office Action dated Apr. 27, 2001," 16 pgs.
 "U.S. Appl. No. 09/382,154, Non Final Office Action dated Apr. 16, 2002," 5 pgs.
 "U.S. Appl. No. 09/382,154, Non Final Office Action dated Oct. 16, 2000," 7 pgs.
 "U.S. Appl. No. 09/382,154, Notice of Allowance dated Sep. 28, 2001," 4 pgs.
 "U.S. Appl. No. 09/382,154, Notice of Allowance dated Oct. 11, 2002," 5 pgs.
 "U.S. Appl. No. 09/382,154, Response filed Feb. 15, 2001 to Non-Final Office Action dated Oct. 16, 2000," 4 pgs.
 "U.S. Appl. No. 09/382,154, Response filed Jul. 15, 2002 to Non-Final Office Action dated Apr. 16, 2002," 9 pgs.
 "U.S. Appl. No. 09/382,292, Amendment filed Dec. 12, 2001," 5 pgs.
 "U.S. Appl. No. 09/382,292, Application filed Aug. 24, 1999," 29 pgs.

(56)

References Cited

OTHER PUBLICATIONS

- "U.S. Appl. No. 09/382,292, Notice of Allowance dated Feb. 28, 2002," 4 pgs.
- "U.S. Appl. No. 09/382,292, Notice of Allowance dated Aug. 27, 2001," 6 pgs.
- "U.S. Appl. No. 09/382,292, Preliminary Amendment filed Aug. 9, 2000," 2 pgs.
- "U.S. Appl. No. 09/382,292, Response filed Jul. 12, 2001 to Restriction Requirement dated Jul. 5, 2001," 1 pg.
- "U.S. Appl. No. 09/382,292, Restriction Requirement dated Jul. 5, 2001," 4 pgs.
- "U.S. Appl. No. 09/572,410, Notice of Allowance dated Jan. 25, 2001," 4 pgs.
- "U.S. Appl. No. 09/572,410, Preliminary Amendment filed May 11, 2000," 9 pgs.
- "U.S. Appl. No. 09/572,410, Response filed Oct. 3, 2000 to Restriction Requirement dated Sep. 5, 2000," 3 pgs.
- "U.S. Appl. No. 09/572,410, Restriction Requirement dated Sep. 5, 2000," 9 pgs.
- "U.S. Appl. No. 09/738,868, Advisory Action dated Feb. 13, 2004," 2 pgs.
- "U.S. Appl. No. 09/738,868, Final Office Action dated Oct. 5, 2004," 6 pgs.
- "U.S. Appl. No. 09/738,868, Final Office Action dated Nov. 26, 2003," 7 pgs.
- "U.S. Appl. No. 09/738,868, Non-Final Office Action dated Apr. 15, 2004," 7 pgs.
- "U.S. Appl. No. 09/738,868, Non-Final Office Action dated Jul. 17, 2003," 7 pgs.
- "U.S. Appl. No. 09/738,868, Notice of Allowance dated Jan. 13, 2005," 6 pgs.
- "U.S. Appl. No. 09/738,868, Request for Continued Examination filed Feb. 24, 2004," 3 pgs.
- "U.S. Appl. No. 09/738,868, Response filed Jan. 23, 2004 to Final Office Action dated Nov. 26, 2003," 14 pgs.
- "U.S. Appl. No. 09/738,868, Response filed Jun. 9, 2003 to Non-Final Office Action dated Apr. 15, 2004," 14 pgs.
- "U.S. Appl. No. 09/738,868, Response filed Oct. 15, 2003 to Non-Final Office Action dated Jul. 17, 2003," 15 pgs.
- "U.S. Appl. No. 09/738,868, Response filed Dec. 6, 2004 to Final Office Action dated Oct. 5, 2004," 17 pgs.
- "U.S. Appl. No. 09/905,054, Non Final Office Action dated May 6, 2003," 3 pgs.
- "U.S. Appl. No. 09/905,054, Notice of Allowance dated Aug. 26, 2003," 5 pgs.
- "U.S. Appl. No. 09/905,054, Preliminary Amendment filed Jul. 12, 2001," 2 pgs.
- "U.S. Appl. No. 09/905,054, Response filed Aug. 9, 2003 to Non Final Office Action dated May 6, 2003," 8 pgs.
- "U.S. Appl. No. 09/905,054, Supplemental Preliminary Amendment filed Nov. 19, 2001," 4 pgs.
- "U.S. Appl. No. 09/907,895, Non Final Office Action dated May 6, 2003," 4 pgs.
- "U.S. Appl. No. 09/907,895, Notice of Allowance dated Aug. 26, 2003," 5 pgs.
- "U.S. Appl. No. 09/907,895, Preliminary Amendment filed Nov. 27, 2001," 4 pgs.
- "U.S. Appl. No. 09/907,895, Response filed Aug. 19, 2003 to Non Final Office Action dated May 6, 2003," 9 pgs.
- "U.S. Appl. No. 10/118,537, Non-Final Office Action dated Apr. 6, 2004," 4 pgs.
- "U.S. Appl. No. 10/118,537, Notice of Allowance dated Sep. 10, 2004," 5 pgs.
- "U.S. Appl. No. 10/118,537, Response filed Jul. 6, 2004 to Non Final Office Action dated Apr. 6, 2004," 10 pgs.
- "U.S. Appl. No. 10/687,433, Advisory Action dated Dec. 28, 2004," 3 pgs.
- "U.S. Appl. No. 10/687,433, Final Office Action dated Aug. 2, 2005," 6 pgs.
- "U.S. Appl. No. 10/687,433, Final Office Action dated Nov. 18, 2004," 6 pgs.
- "U.S. Appl. No. 10/687,433, Non Final Office Action dated Mar. 1, 2005," 5 pgs.
- "U.S. Appl. No. 10/687,433, Non-Final Office Action dated Jun. 21, 2004," 6 pgs.
- "U.S. Appl. No. 10/687,433, Notice of Allowance dated Dec. 16, 2005," 4 pgs.
- "U.S. Appl. No. 10/687,433, Response filed Jun. 1, 2005 to Non-Final Office Action dated Mar. 1, 2005," 14 pgs.
- "U.S. Appl. No. 10/687,433, Response filed Sep. 21, 2004 to Non-Final Office Action dated Jun. 21, 2004," 8 pgs.
- "U.S. Appl. No. 10/687,433, Response filed Dec. 2, 2005 to Final Office Action dated Aug. 2, 2005," 9 pgs.
- "U.S. Appl. No. 10/687,433, Response filed Dec. 10, 2004 to Final Office Action dated Nov. 18, 2004," 8 pgs.
- "U.S. Appl. No. 10/747,391, Advisory Action dated Jun. 10, 2009," 4 pgs.
- "U.S. Appl. No. 10/747,391, Advisory Action dated Jul. 16, 2010," 3 pgs.
- "U.S. Appl. No. 10/747,391, Final Office Action dated Mar. 19, 2009," 9 pgs.
- "U.S. Appl. No. 10/747,391, Final Office Action dated Mar. 31, 2010," 8 pgs.
- "U.S. Appl. No. 10/747,391, Final Office Action dated Dec. 30, 2008," 9 pgs.
- "U.S. Appl. No. 10/747,391, Non Final Office Action dated Jun. 2, 2008," 9 pgs.
- "U.S. Appl. No. 10/747,391, Non Final Office Action dated Sep. 2, 2009," 9 pgs.
- "U.S. Appl. No. 10/747,391, Non Final Office Action dated Nov. 26, 2007," 18 pgs.
- "U.S. Appl. No. 10/747,391, Notice of Allowance dated Feb. 4, 2011," 4 pgs.
- "U.S. Appl. No. 10/747,391, Response filed Feb. 12, 2007 to Restriction Requirement dated Jan. 12, 2007," 7 pgs.
- "U.S. Appl. No. 10/747,391, Response filed Feb. 24, 2009 to Final Office Action dated Dec. 30, 2008," 10 pgs.
- "U.S. Appl. No. 10/747,391, Response filed Feb. 25, 2008 to Non Final Office Action dated Nov. 26, 2007," 13 pgs.
- "U.S. Appl. No. 10/747,391, Response filed May 18, 2009 to Final Office Action dated Mar. 19, 2009," 11 pgs.
- "U.S. Appl. No. 10/747,391, Response filed Jun. 30, 2010 to Final Office Action dated Mar. 31, 2010," 9 pgs.
- "U.S. Appl. No. 10/747,391, Response filed Jul. 20, 2009 to Advisory Action dated Jun. 10, 2009," 11 pgs.
- "U.S. Appl. No. 10/747,391, Response filed Sep. 2, 2008 to Non Final Office Action dated Jun. 2, 2008," 10 pgs.
- "U.S. Appl. No. 10/747,391, Response filed Dec. 2, 2009 to Non Final Office Action dated Sep. 2, 2009," 12 pgs.
- "U.S. Appl. No. 10/747,391, Restriction Requirement dated dated Jan. 12, 2007," 6 pgs.
- "U.S. Appl. No. 11/021,141, Non-Final Office Action dated Jul. 26, 2007," 6 pgs.
- "U.S. Appl. No. 11/021,141, Notice of Allowance dated Apr. 22, 2008," 4 pgs.
- "U.S. Appl. No. 11/021,141, Response filed Oct. 26, 2007 to Office Action dated Jul. 26, 2007," 9 pgs.
- "U.S. Appl. No. 11/021,141, Supplemental Notice of Allowability dated Jun. 25, 2008," 3 pgs.
- "U.S. Appl. No. 11/115,618, Final Office Action dated Jan. 8, 2008," 8 pgs.
- "U.S. Appl. No. 11/115,618, Final Office Action dated Aug. 24, 2007," 11 pgs.
- "U.S. Appl. No. 11/115,618, Non-Final Office Action dated Mar. 12, 2007," 10 pgs.
- "U.S. Appl. No. 11/115,618, Notice of Allowance dated Apr. 2, 2008," 4 pgs.
- "U.S. Appl. No. 11/115,618, Response filed Oct. 22, 2007 to Final Office Action dated Aug. 24, 2007," 15 pgs.
- "U.S. Appl. No. 11/115,618, Response filed Mar. 4, 2008 to Final Office Action dated Jan. 8, 2008," 9 pgs.

(56)

References Cited

OTHER PUBLICATIONS

- "U.S. Appl. No. 11/115,618, Response filed Jun. 12, 2007 to Non-Final Office Action dated Mar. 12, 2007," 13 pgs.
- "U.S. Appl. No. 11/379,912 Notice of Allowance dated Jul. 26, 2010," 4 pgs.
- "U.S. Appl. No. 11/379,912, Examiner Interview Summary dated Sep. 22, 2009," 2 pgs.
- "U.S. Appl. No. 11/379,912, Final Office Action dated Sep. 10, 2008," 9 pgs.
- "U.S. Appl. No. 11/379,912, Non-Final Office Action dated Feb. 25, 2008," 8 pgs.
- "U.S. Appl. No. 11/379,912, Non-Final Office Action dated Mar. 25, 2009," 8 pgs.
- "U.S. Appl. No. 11/379,912, Notice of Allowance dated Dec. 21, 2009," 4 pgs.
- "U.S. Appl. No. 11/379,912, Response filed Jan. 12, 2009 to Final Office Action dated Sep. 10, 2008," 9 pgs.
- "U.S. Appl. No. 11/379,912, Response filed May 14, 2008 to Non Final Office Action dated Feb. 25, 2008," 8 pgs.
- "U.S. Appl. No. 11/379,912, Response filed Sep. 23, 2009 to Non Final Office Action dated Mar. 25, 2009," 14 pgs.
- "U.S. Appl. No. 12/169,432, Non Final Office Action dated Dec. 28, 2010," 6 pgs.
- "U.S. Appl. No. 12/169,432, Notice of Allowance dated Jun. 10, 2011," 9 pgs.
- "U.S. Appl. No. 12/169,432, Response filed Mar. 28, 2011 to Non Final Office Action dated Dec. 28, 2010," 9 pgs.
- "U.S. Appl. No. 12/220,830, Final Office Action dated Feb. 8, 2011," 6 pgs.
- "U.S. Appl. No. 12/220,830, Non Final Office Action dated Sep. 13, 2010," 6 pgs.
- "U.S. Appl. No. 12/220,830, Response filed Dec. 8, 2010 to Non Final Office Action dated Sep. 13, 2010," 8 pgs.
- "U.S. Appl. No. 12/220,830, Response filed Aug. 8, 2011 to Final Office Action dated Feb. 8, 2011," 7 pgs.
- "U.S. Appl. No. 12/941,377, Non-Final Office Action dated May 9, 2011," 6 pgs.
- "U.S. Appl. No. 12/941,377, Notice of Allowance dated Oct. 21, 2011," 5 pgs.
- "U.S. Appl. No. 12/941,377, Response filed Sep. 6, 2011 to Non-Final Office Action dated May 9, 2011," 8 pgs.
- "U.S. Appl. No. 13/158,955, Examiner Interview Summary dated Feb. 17, 2012," 3 pgs.
- "U.S. Appl. No. 13/158,955, Final Office Action dated Jun. 22, 2012," 5 pgs.
- "U.S. Appl. No. 13/158,955, Non Final Office Action dated Mar. 5, 2012," 5 pgs.
- "U.S. Appl. No. 13/158,955, Non Final Office Action dated Oct. 10, 2012," 5 pgs.
- "U.S. Appl. No. 13/158,955, Non Final Office Action dated Oct. 19, 2011," 5 pgs.
- "U.S. Appl. No. 13/158,955, Notice of Allowance dated Feb. 15, 2013," 6 pgs.
- "U.S. Appl. No. 13/158,955, Response filed Jan. 8, 2013 to Non Final Office Action dated Oct. 10, 2012," 10 pgs.
- "U.S. Appl. No. 13/158,955, Response filed Jun. 5, 2012 to Non Final Office Action dated Mar. 5, 2012," 12 pgs.
- "U.S. Appl. No. 13/158,955, Response filed Sep. 21, 2012 to Final Office Action dated Jun. 22, 2012," 10 pgs.
- "U.S. Appl. No. 13/247,473, Non Final Office Action dated Aug. 15, 2013," 7 pgs.
- "U.S. Appl. No. 13/247,473, Notice of Allowance dated Dec. 26, 2013," 6 pgs.
- "U.S. Appl. No. 13/247,473, Response filed Nov. 11, 2013 to Non Final Office Action dated Aug. 15, 2013," 9 pgs.
- "U.S. Appl. No. 13/411,063, Final Office Action dated Apr. 9, 2013," 5 pgs.
- "U.S. Appl. No. 13/411,063, Non Final Office Action dated Nov. 28, 2012," 8 pgs.
- "U.S. Appl. No. 13/411,063, Notice of Allowance dated Jun. 13, 2013," 6 pgs.
- "U.S. Appl. No. 13/411,063, Response filed Mar. 26, 2013 to Non Final Office Action dated Nov. 28, 2012," 10 pgs.
- "U.S. Appl. No. 13/411,063, Response filed Jun. 4, 2013 to Final Office Action dated Apr. 9, 2013," 6 pgs.
- "U.S. Appl. No. 13/964,893, Advisory Action dated Mar. 28, 2014," 3 pgs.
- "U.S. Appl. No. 13/964,893, Final Office Action dated Jan. 27, 2014," 8 pgs.
- "U.S. Appl. No. 13/964,893, Non Final Office Action dated Oct. 10, 2013," 7 pgs.
- "U.S. Appl. No. 13/964,893, Notice of Allowance dated May 15, 2014," 8 pgs.
- "U.S. Appl. No. 13/964,893, Response Filed Jan. 2, 2014 to Non-Final Office Action dated Oct. 10, 2013," 9 pgs.
- "U.S. Appl. No. 13/964,893, Response filed Mar. 20, 2014 to Final Office Action dated Jan. 27, 2014," 9 pgs.
- "U.S. Appl. No. 13/964,893, Response filed Apr. 28, 2014 to Final Office Action dated Jan. 27, 2014," 9 pgs.
- File History for Related U.S. Appl. No. 09/738,869 downloaded Mar. 9, 2017, 67 pages.
- Hiebert, J F. et al., "Event Marker Alignment by Inclusion of Event Marker Transmission Latency in the Real-Time Data Stream," Application Serial No., pp. 1-28.
- "International Application No. PCT/US00/22644, International Preliminary Examination Report dated Sep. 27, 2001," 6 pgs.
- "International Application Serial No. PCT/US00/22644, International Search Report dated Nov. 15, 2000," 3 pgs.
- "International Application Serial No. PCT/US00/22644, Written Opinion dated Jul. 25, 2001," 5 pgs.
- "Non-Final Office Action," for U.S. Appl. No. 14/879,724, dated Apr. 21, 2016 (33 pages).
- "Notice of Allowance," for U.S. Appl. No. 14/480,962, dated Jun. 8, 2015 (5 pages).
- "Notice of Allowance," for U.S. Appl. No. 14/879,724 dated Aug. 16, 2016 (5 pages).
- Tanenbaum, A S. "Computer Networks," Prentice-Hall, Inc., Englewood Cliffs, NJ, (1981), 125-128.
- "Vigor Model 2950 Physician's System Manual," (1996), 87 pgs.

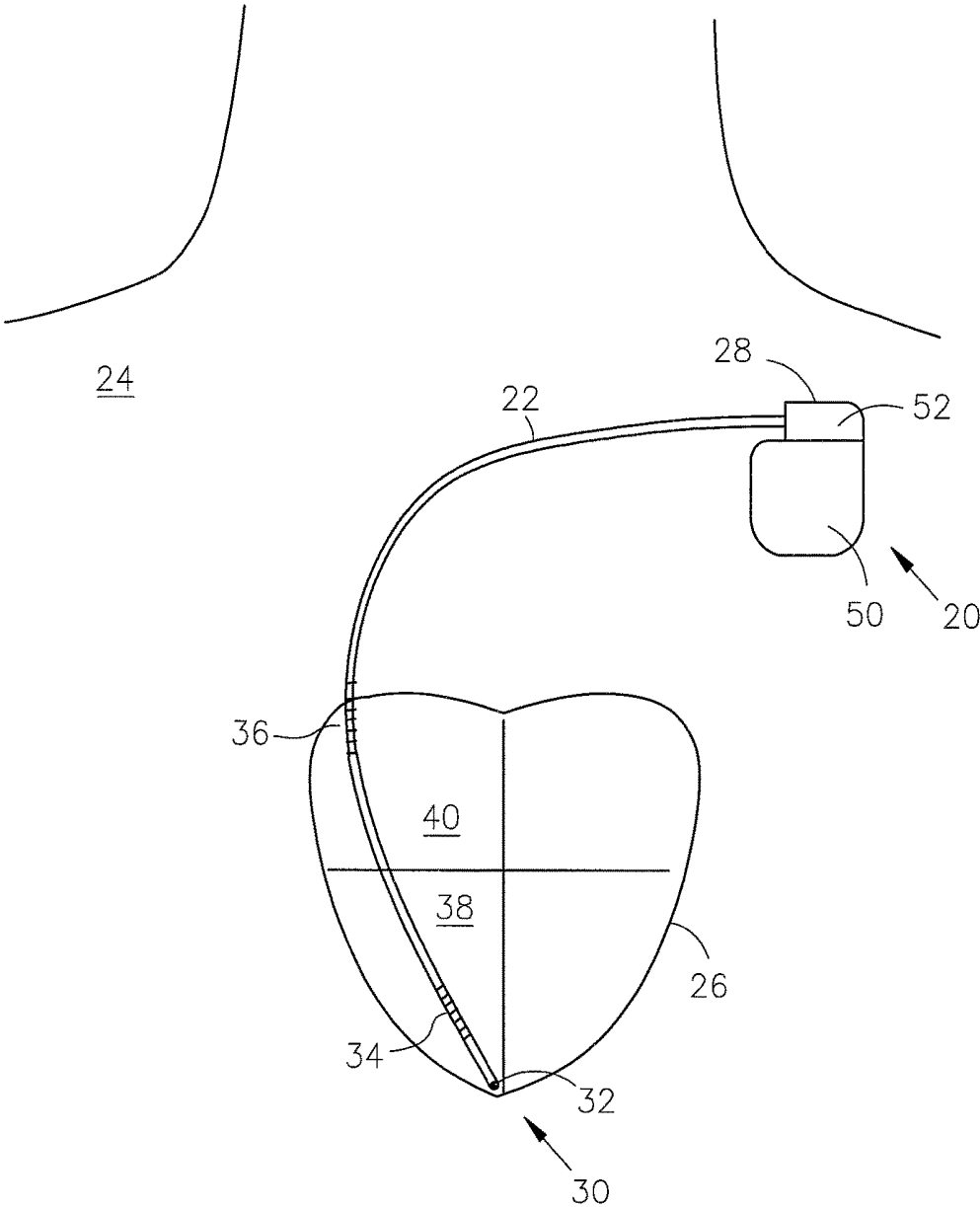

Fig.1

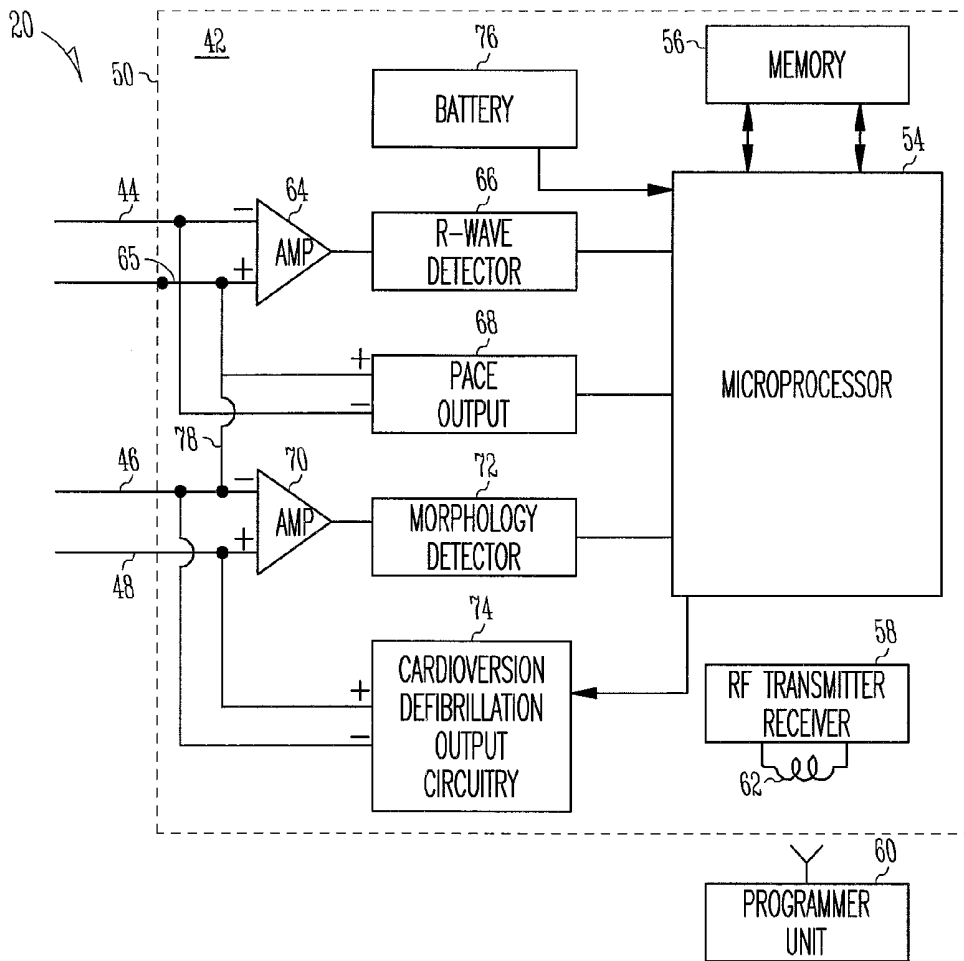

Fig.2

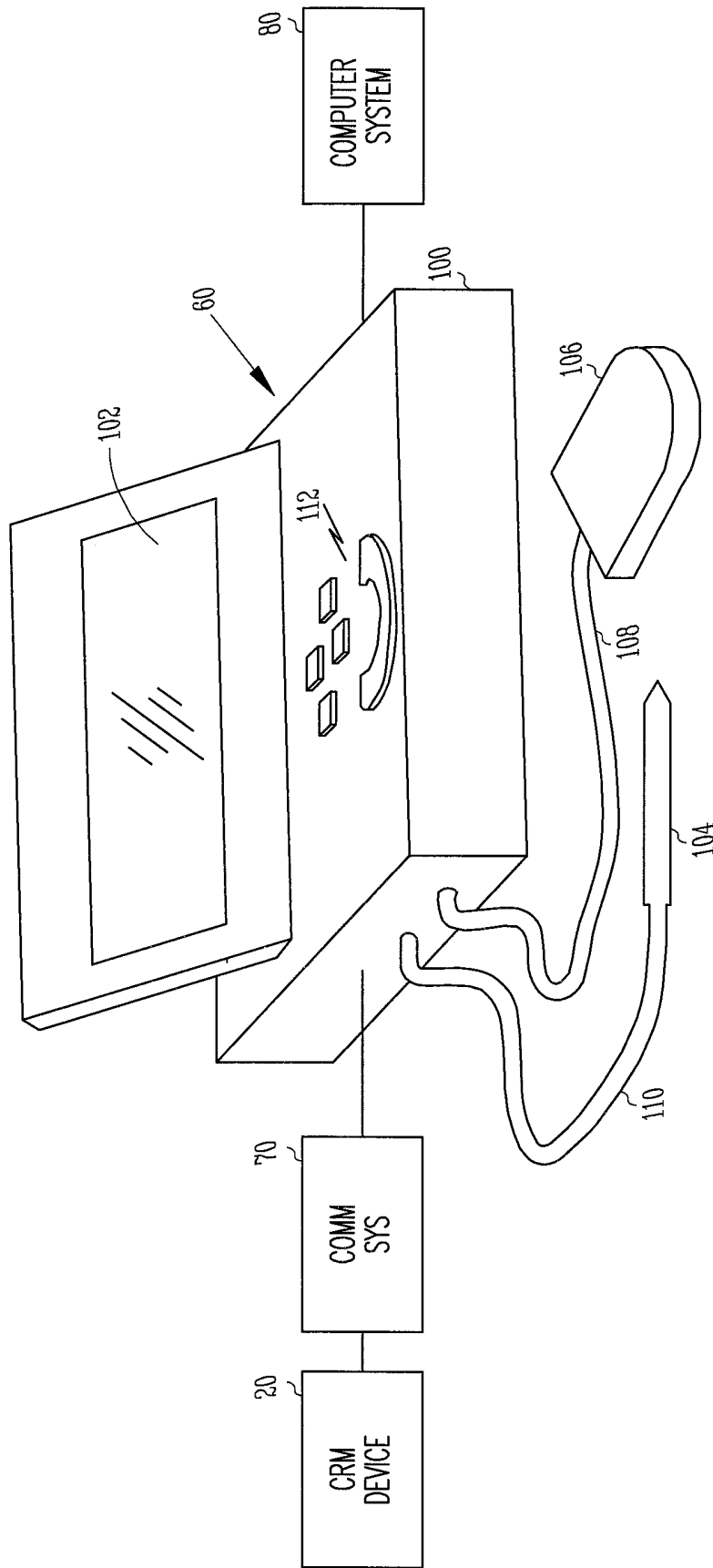

Fig.3

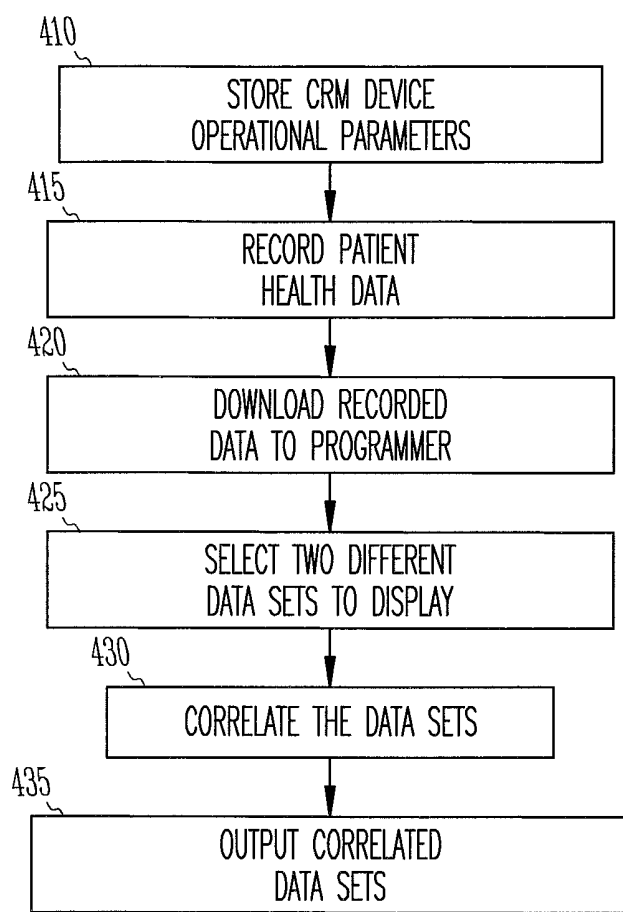

Fig.4

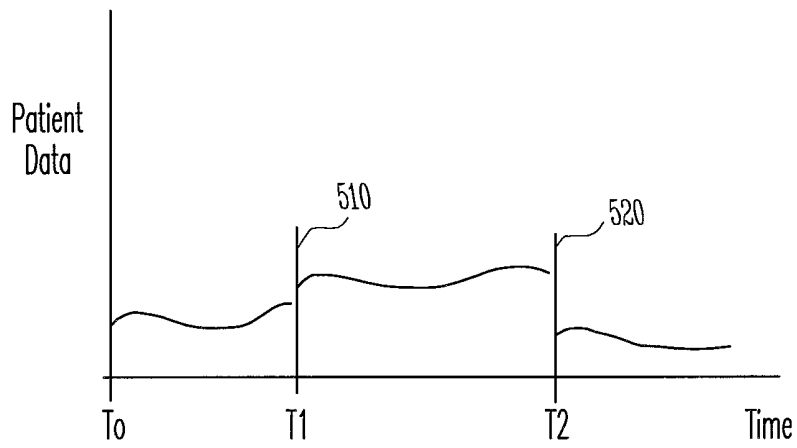

Fig.5

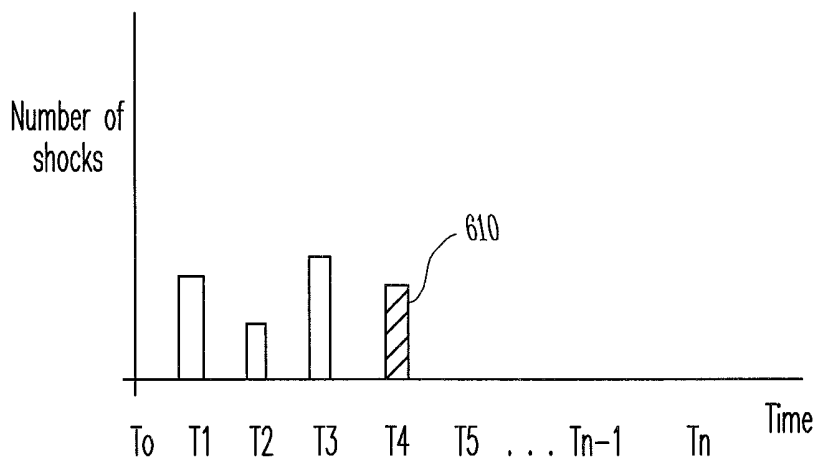

Fig.6

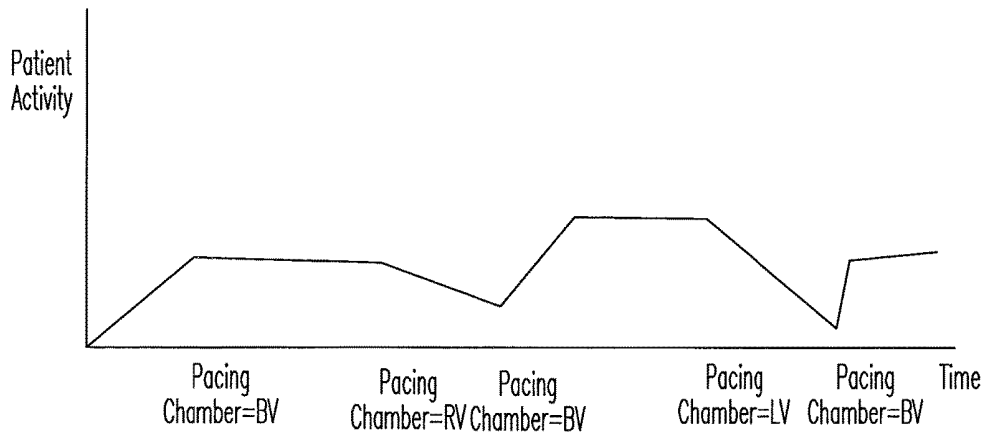

Fig.7

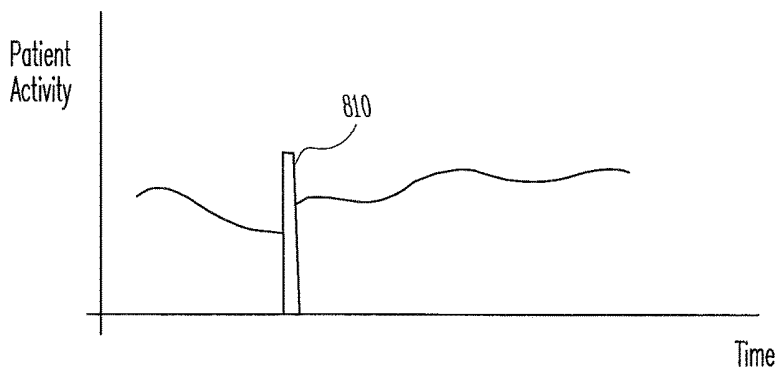

Fig.8

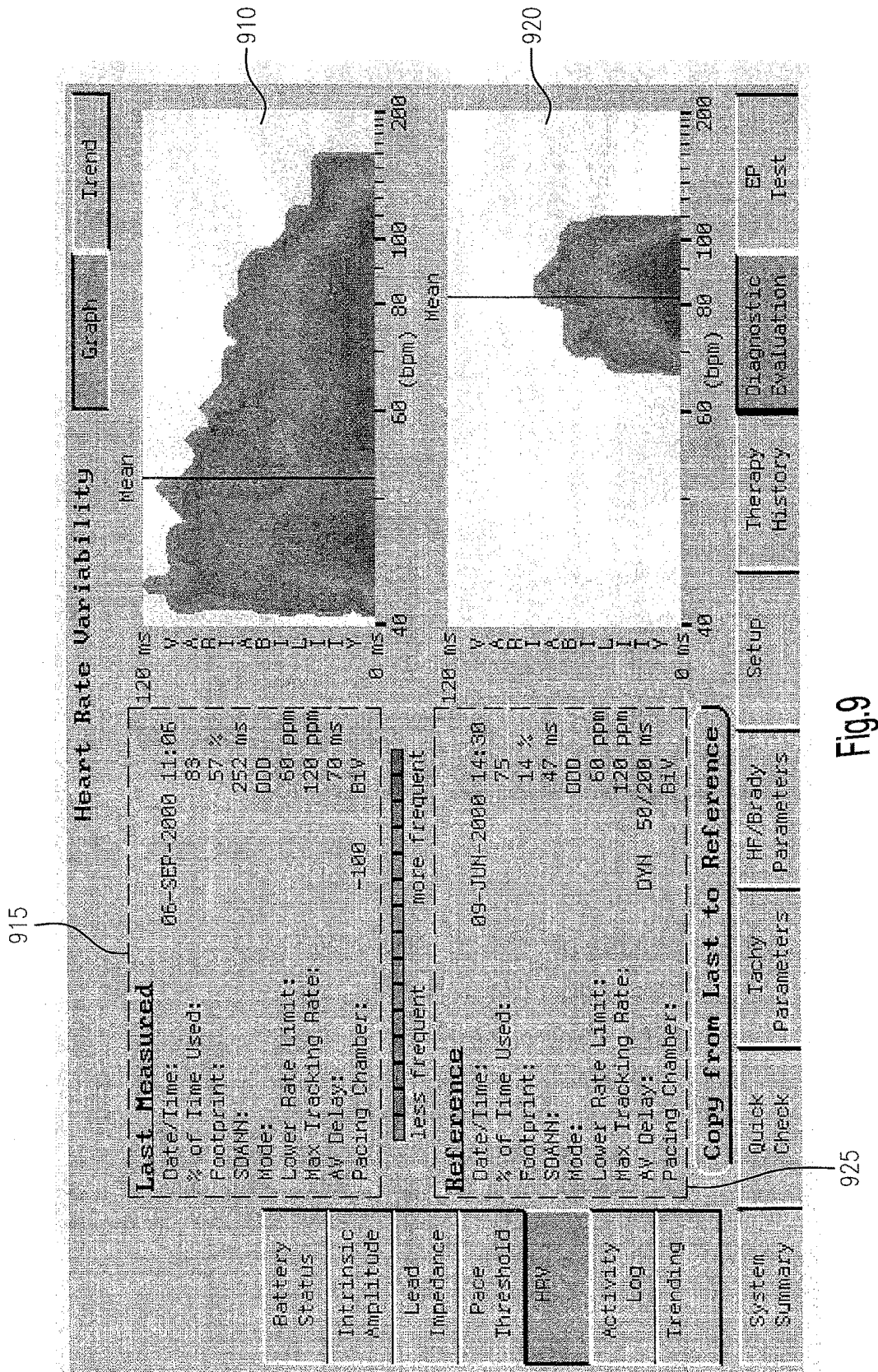

Fig.9

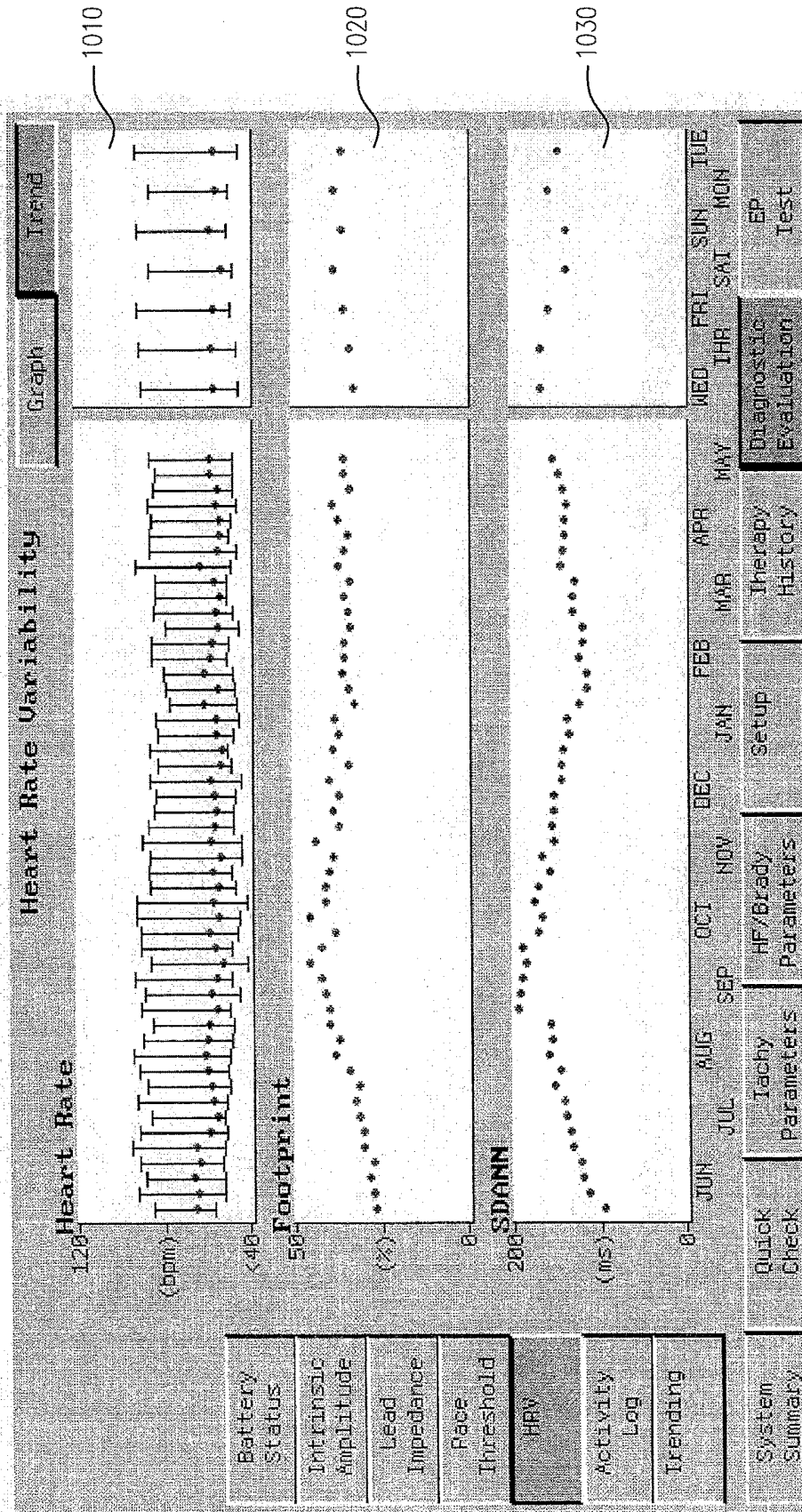

Fig.10

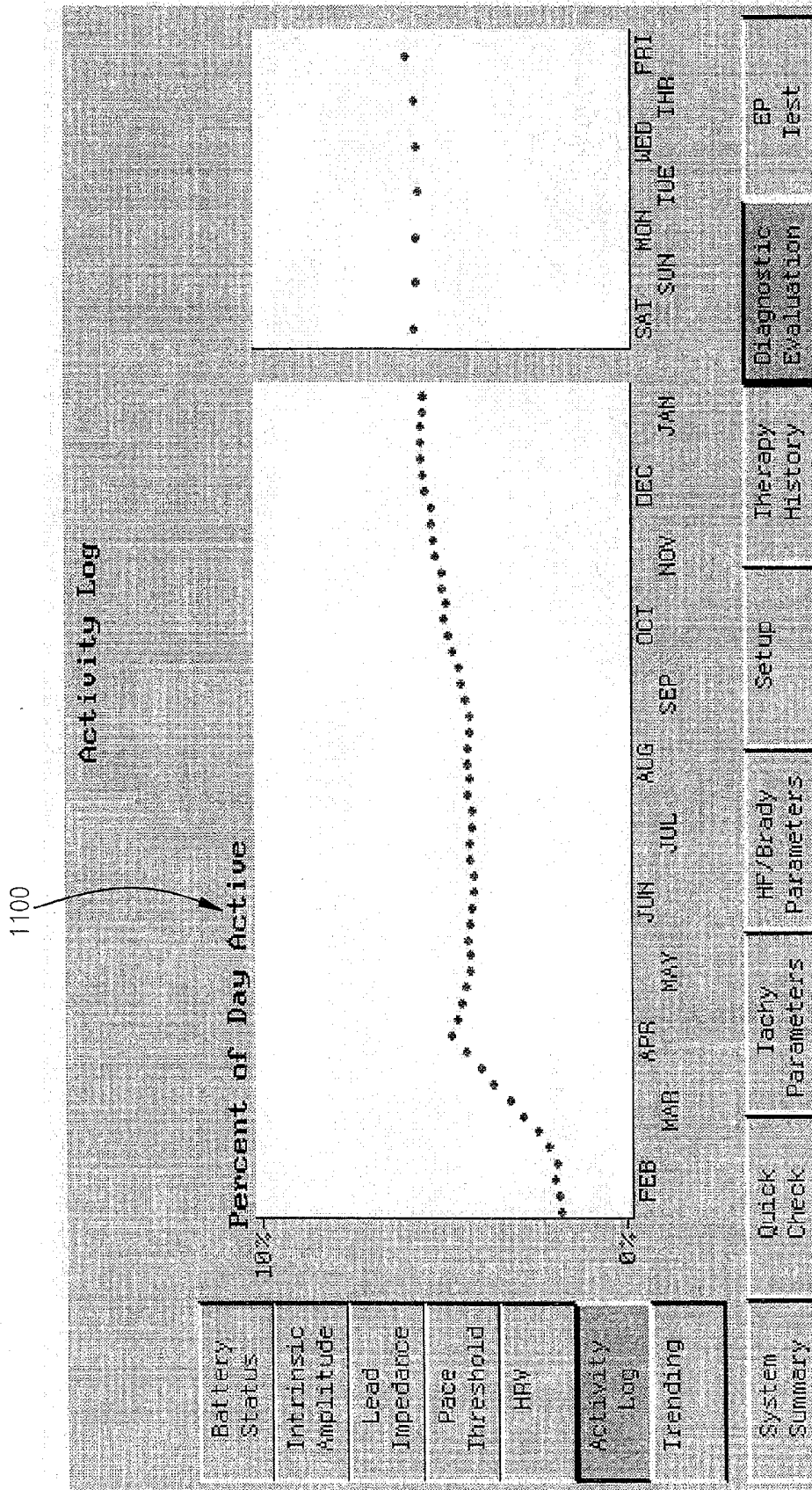

Fig.11

SYSTEM AND METHOD FOR CORRELATION OF PATIENT HEALTH INFORMATION AND DEVICE DATA

CROSS-REFERENCE TO RELATED APPLICATIONS

This application is a continuation of U.S. patent application Ser. No. 14/879,724, filed on Oct. 9, 2015, which is a continuation of U.S. patent application Ser. No. 14/480,962, filed on Sep. 9, 2014, now issued as U.S. Pat. No. 9,155,904, which is a continuation of U.S. patent application Ser. No. 13/964,893, filed on Aug. 12, 2013, now issued as U.S. Pat. No. 8,838,220, which is a continuation of U.S. patent application Ser. No. 13/411,063, filed on Mar. 2, 2012, now issued as U.S. Pat. No. 8,548,576, which is a continuation of U.S. patent application Ser. No. 12/941,377, filed on Nov. 8, 2010, now issued as U.S. Pat. No. 8,131,351, which is a continuation of U.S. patent application Ser. No. 11/379,912, filed on Apr. 24, 2006, now issued as U.S. Pat. No. 7,844,322, which is a continuation of U.S. patent application Ser. No. 10/687,433, filed on Oct. 16, 2003, now issued as U.S. Pat. No. 7,047,065, which is a continuation of U.S. patent application Ser. No. 09/738,869, filed on Dec. 15, 2000, now issued as U.S. Pat. No. 6,665,558, the specifications of which are incorporated herein by reference.

FIELD OF THE INVENTION

This invention pertains to a system and method of correlating general patient health information and implant device data, and more particularly for correlating patient health information and cardiac rhythm management device data.

BACKGROUND

Implantable cardiac rhythm management devices ("CRM devices") are well established therapeutic devices for treating patients who have experienced one or more documented episodes of hemodynamically significant ventricular tachycardia, ventricular fibrillation, bradycardia, or heart failure. Since their clinical inception more than two decades ago, CRM devices have evolved from basic to sophisticated electronic devices that provide physicians with a variety of clinically useful functions with which to treat patients.

Presently, even the most basic of CRM device typically has more than one tachycardia detection criterion, tiered therapy which combines bradycardia support pacing with various antitachycardia pacing modes, low-energy cardioversion, defibrillation, and data logging capabilities. The data logging capabilities within CRM devices have become increasingly important, since the amount of data required for the CRM device operation increases proportionally with the increase in CRM functions. Efficiently processing this large amount of data has become possible with the incorporation of microprocessors and memory within the CRM device.

Once a CRM device has been implanted, the physician interacts with the CRM device through a clinical programmer. The clinical programmer establishes a communication link with the implanted CRM device. The communication link allows instructions to be sent to the electronic circuitry of the CRM device and clinical data regarding the occurrence and treatment of a patient's cardiac arrhythmias and the CRM device's operation to be sent from the electronic circuitry of the CRM device to the clinical programmer. The typical programmer is a microprocessor-based unit that creates a communication link between the implanted CRM

device and the programmer, and a graphics display screen that presents a patient's recorded cardiac data and CRM system information to the physician.

As the number of differing health data recorded by CRM device increases with each new generation of CRM device and the number of general patient health data increases, manufacturers and clinicians alike are becoming more sensitive to the role that time-efficient data interpretation plays in the physician's diagnosis of the patient. As CRM devices become increasingly complex, the interpretation of recorded arrhythmic episodes, operation of the CRM device, and the effect of changing a patient's therapy can be a challenging and time-consuming task.

Therefore, a need exists for improved CRM system and programmer technology that facilitates and correlates the identification of relevant information regarding the patient's clinical status. There is a need in the art for a system that correlates multiple data sets and displays same to the physician.

SUMMARY OF THE INVENTION

The present invention is generally directed to a system and method for presenting data from the CRM device simultaneously with patient health data and/or other patient data. The data so presented provides a physician with a visual display of more than one data set and thus the correlation between the data. Such a display may aid the physician in diagnosing and treating a patient.

Accordingly, one embodiment provides a cardiac rhythm management system including a cardiac rhythm management device and a programmer, the programmer being adapted to receive data from the cardiac rhythm management device. The programmer is adapted to correlate a first data set and a second data set for display to a physician. The first data set may be continuous, asynchronous or periodic data. The second data set may be asynchronous, continuous, or periodic data.

In another embodiment of the invention, the data is downloaded from the programmer into a data processor, which correlates the data. The correlated data is then output to a display device. One example of a data processor is a computer running appropriate software. One example of the display device is a computer monitor.

A further embodiment provides a display of the reoccurring first data against time and a second data imposed on the time axis to indicate a change in the patient's therapy. The second data may include changes to a patient's therapy including medication changes, medical device changes, or changes in operational parameters of a medical device.

Another embodiment provides a graphical display of data of the same type, which were recorded under different conditions, for example at different times or when the patient was under different treatment. The different circumstances are also displayed.

In another embodiment, the same type of data is heart rate variability data and the different circumstances may be the time at which the heart rate variability data was measured.

These and other embodiments, aspects, advantages, and features of the present invention will be set forth in part in the description which follows, and in part will become apparent to those skilled in the art by reference to the following description of the invention and referenced drawings or by practice of the invention. The aspects, advantages, and features of the invention are realized and attained by

means of the instrumentalities, procedures, and combinations particularly pointed out in the appended claims.

BRIEF DESCRIPTION OF THE DRAWINGS

FIG. 1 is an embodiment of an implantable cardiac rhythm management device.

FIG. 2 is a block diagram of an implantable cardiac rhythm management device.

FIG. 3 is a perspective view of a programmer unit and computer system.

FIG. 4 is a flow chart of an embodiment of the present invention.

FIG. 5 is a graph of a patient's therapy history and further patient health/therapy data verses time according to one embodiment of the invention.

FIG. 6 is a graph of a patient's therapy history and change in ventricular sensitivity verses time according to one embodiment of the invention.

FIG. 7 is a graph of a patient's activity and pacing chamber versus time according to one embodiment of the invention.

FIG. 8 is a graph of a patient's activity and change in accelerometer versus time according to one embodiment of the invention.

FIG. 9 is a display simultaneously showing two Heart Rate Variability graphs according to one embodiment of the invention.

FIG. 10 is a display of trend data associated with Heart Rate Variability measurements according to one embodiment of the invention.

FIG. 11 is a display of an activity log recorded by a CRM device.

DESCRIPTION OF THE INVENTION

In the following detailed description of the invention, reference is made to the accompanying drawings which form a part hereof, and in which is shown, by way of illustration, specific embodiments in which the invention may be practiced. These embodiments are described in sufficient detail to enable those skilled in the art to practice the invention. Other embodiments may be utilized and structural, logical, and electrical changes may be made without departing from the scope of the present invention.

The embodiments of the present invention illustrated herein are described as being included in a cardiac rhythm management device, e.g. an implantable cardiac defibrillator, pacemaker, or heart failure treatment device, which may include numerous pacing modes known in the art, and an external medical device programmer. The medical system and method of the present invention could also be implemented in an external cardioverter/monitor system as are known in the art. The medical system and method of the present invention could also be implemented in an implantable atrial cardioverter-defibrillator, which may include numerous pacing modes known in the art. Furthermore, although the present invention is described in conjunction with an implantable defibrillator having a microprocessor based architecture, it will be understood that the implantable cardiac defibrillator (or other implanted device) may be implemented in any logic based, custom integrated circuit architecture, if desired.

FIG. 1 shows one embodiment of a medical device system which includes a CRM device 20 electrically and physically coupled to at least one lead 22 such as an intracardiac catheter, epicardial lead, or coronary vein lead. In one

embodiment, the intracardiac catheter 22 includes one or more pacing electrodes and one or more intracardiac defibrillation electrodes.

The intracardiac catheter 22 is implanted in a human body 24 with portions of the intracardiac catheter 22 inserted into a heart 26 or placed on the heart 26 to detect and analyze electric cardiac signals produced by the heart 26 and to provide electrical energy to the heart 26 under certain predetermined conditions to treat cardiac arrhythmias of the heart 26, including ventricular fibrillation, bradycardia and/or heart failure.

In one embodiment, the intracardiac catheter 22 is an endocardial lead adapted to be releasably attached to CRM device 20. The intracardiac catheter 22 has an elongate body with a proximal end 28 and a distal end 30 and is shown as having a pacing electrode 32 located at, or adjacent, the distal end 30 of intracardiac catheter 22. In one embodiment, the pacing electrode 32 is a tip electrode positioned at the distal end 30 of intracardiac catheter 22. Alternatively, pacing electrode 32 is an annular, or a semi-annular ring electrode positioned adjacent the distal end 30.

The intracardiac catheter 22 also includes one or more defibrillation electrodes. In one embodiment, the intracardiac catheter 22 has a first defibrillation electrode 34 and a second defibrillation electrode 36, where the first defibrillation electrode 34 and the second defibrillation electrode 36 are defibrillation coil electrodes. The first defibrillation electrode 34 is spaced apart and proximal to the pacing electrode 32, and the second defibrillation electrode 36 is spaced apart and proximal to the first defibrillation electrode 34 such that when the intracardiac catheter 22 is positioned within the heart 26, the pacing electrode 32 and first defibrillation electrode 34 reside within a right ventricle 38 of the heart 26, with pacing electrode 32 in an apex location within the right ventricle 38, and second defibrillation electrode 36 is positioned within the right atrium chamber 40 of heart 26 or a major vein leading to right atrium chamber 40 of heart 26. The description of catheter 22 is but one example of various leads, known to one of skill in the art, that will work with the present invention. As a further example CRM device 20 may be connected to a plurality of leads.

FIG. 2 shows an embodiment of a block diagram of CRM device 20. The CRM device 20 includes electronic control circuitry 42 for receiving cardiac signals from heart 26 and delivering electrical energy to heart 26. The electronic control circuitry 42 includes terminals, labeled with reference numbers 44, 46, and 48 for connection to electrodes attached to the surface of intracardiac catheter 22. Pacing electrode 32 is electrically connected to terminal 44 and to the electronic control circuitry 42 through an electrically insulated conductor provided within the elongate body of intracardiac catheter 22. The first defibrillation electrode 34 and the second defibrillation electrode 36 are connected to terminals 46 and 48, respectively, and to electronic control circuitry 42 through electrically insulated conductors provided within the elongate body of intracardiac catheter 22.

In one embodiment, electronic control circuitry 42 of CRM device 20 is encased and hermetically sealed in a housing 50 suitable for implanting in a human body. In one embodiment, titanium is used for the housing 50, however, other biocompatible housing materials as are known in the art may be used. A connector block 52 is additionally attached to the housing 50 of CRM device 20 to allow for the physical and the electrical attachment of the intracardiac catheter 22 and the electrodes to CRM device 20 and the encased electronic control circuitry 42 (FIG. 1).

Electronic control circuitry **42** is a programmable microprocessor-based system, with a microprocessor **54** and a memory circuit **56**, which contains parameters for various pacing and sensing modes (FIG. 2). Memory circuit **56** stores data indicative of cardiac signals received by the electronic control circuitry **42**. In one embodiment, data stored in the memory circuit **56** includes arrhythmia episode details, such as: a raw electrocardiogram signals, including two or more channels such as a ventricular signal and an atrial signal; a chronological number of the episode; the date and time of the episode; the type of episode detected; the onset rate of the episode; the stability of the episode; the duration of the episode; pre-therapy and post-therapy average atrial and ventricular rates; and the type of therapy delivered. Other arrhythmia episode data known in the art can also be recorded and stored in memory circuit **56**. Moreover, the data stored in memory circuit **56** can include lead impedance measurements, pacing threshold measurements, brady pacing parameters, and programmed therapy parameters. The stored data may also include patient health data, for example, maximum heart rate, heart rate variability data, and blood pressure measurements.

Electronic control circuitry **42** further includes transmitter circuit **58** which is coupled to memory circuit **56** to allow the CRM device **20** to communicate with a programmer unit **60**. In one embodiment, transmitter circuit **58** and programmer unit **60** use a wire loop antenna **62** and a radio frequency telemetric link to receive and transmit signals and data to and from the programmer unit **60** and the electronic control circuitry **42**. In another embodiment, the transmitter circuit **58** includes inductive coils to bidirectionally transmit signals and data between programmer unit **60** and electronic control circuitry **42**. In these manners, programming commands or instructions are transferred to the microprocessor **54** of CRM device **20** after implant, and stored cardiac data pertaining to patient health, including sensed arrhythmic episodes within the heart **26**, and subsequent therapy, or therapies, applied to correct sensed arrhythmic events are transferred to programmer unit **60** from CRM device **20**. It is within the scope of the present invention to transmit any data stored in CRM device **20** to programmer unit **60** so the data can be analyzed and used by a physician to diagnose and evaluate the efficacy of the therapy.

Pacing electrode **32** is coupled to a sense amplifier **64** through terminal **44** in the FIG. 2 embodiment. In an additional embodiment, the housing **50** of CRM device **20** is also coupled to the sense amplifier **64** at **65** to allow for unipolar cardiac rate sensing between the pacing electrode **32** and the housing **50** of CRM device **20**. The output of the sense amplifier **64** is shown connected to an R-wave detector **66**. These components serve to sense and amplify the QRS waves of the heart, and apply signals indicative thereof to the microprocessor **54**. Among other things, microprocessor **54** responds to the R-wave detector **66** by providing pacing signals to a pace output circuit **68**, as needed according to the programmed pacing mode. Pace output circuit **68** provides output pacing signals to terminals **44** and **46**, which connect to the pacing electrode **32** and defibrillation electrode **34**, for cardiac pacing. As illustrated in FIG. 2, the pace output circuit is also connected to housing **50** at terminal **65** and through connection **78** to terminal **46**. In another embodiment, the connection to defibrillation electrode **34** is accomplished by intracardiac catheter **22** instead of CRM device **20**. As will be appreciated by one of skill in the art, this is one of many structures for sensing cardiac rates and production of cardiac rhythm management signals.

First defibrillation electrode **34** and second defibrillation electrode **36** are coupled to a sense amplifier **70**, whose output is connected to a cardiac morphology detector **72**. These components serve to sense and amplify the QRS-waves of the cardiac cycle from the ventricular region of the heart **26**, and apply signals indicative thereof to the microprocessor **54**. In one embodiment, the cardiac morphology detector **72** includes an analog filter for filtering cardiac signal noise sensed by the electrodes. The cardiac signals are then band limited before arriving at an analog-to-digital filter. The cardiac signals are then A/D converted into a digital signal and subsequently received by microprocessor **54**. In an alternative embodiment, the cardiac signals are filtered through an analog peak detector to extract the maximum and minimum cardiac signal values for each sensed cardiac interval.

Microprocessor **54** responds to the cardiac signals sensed within the heart **26** using the intracardiac catheter **22** by providing signals to cardioversion/defibrillation output circuitry **74** to provide either cardioversion or defibrillation electrical energy to the heart **26** depending upon nature of an arrhythmia sensed by CRM device **20**. Power to CRM device **20** is supplied by an electrochemical battery **76** that is housed within CRM device **20**.

While the illustrative embodiment shown in FIG. 2 has R-Wave detector **66** and morphology detector **72**, it is understood that one or the other of these detectors could be removed from the CRM device **20**. Moreover, other detectors could be installed in CRM device **20** to monitor various health data of a patient.

Referring now to FIG. 3, there is shown one embodiment of a medical device programmer **60** of the medical device system. As previously mentioned, one embodiment of the medical device programmer **60** for the implantable CRM device **20** takes the form of an external controller. However, in an alternative embodiment, the medical device system is a completely external device such as an external cardioverting/defibrillator system as are known in the art, where the programmer unit is physically and electronically integrated into electronic control circuitry similar to the electronic control circuitry **42** of CRM device **20**. An example of this latter embodiment is for an external cardiac monitor and defibrillation unit, electrically connected to the heart by any combination of intracardiac catheters, epicardial electrodes and/or external cardiac electrodes.

Medical device programmer **60** is designed to be positioned external of the human body **24** for communicating with an implantable medical device, such as CRM device **20** from FIG. 1, for example via RF telemetry. Medical device programmer **60** has programmer electronic circuitry, including a microprocessor and related circuitry, such as digital memory, which is coupled to an output unit, which is here shown as graphics display screen **102**.

In one embodiment, the medical device programmer **60** comprises an outer housing **100** which is made of a thermal plastic or other suitable lightweight durable material. The graphics display screen **102** is disposed on the upper surface of housing **100**. The graphics display screen **102** folds down into a closed position when medical device programmer **60** is not in use, thereby reducing the size of medical device programmer **60** and protecting the display surface of graphics display screen **102** during transportation and storage. In an additional embodiment, the external programmer additionally has a floppy disk drive and a hard drive disposed within the housing.

The medical device programmer **60** is shown with the graphics display screen **102** positioned in one of a plurality

of possible open positions such that a display on the graphics display screen 102 is visible to a user situated in front of medical device programmer 60. In one embodiment, the graphics display screen 102 is of a CRT, LCD or electroluminescent type. The graphics display screen 102 is operatively coupled to the electronic circuitry disposed with the housing 100 and is adapted to provide a visual display of graphics and/or data under control of the programmer electronic circuitry, e.g. processor. It is within the scope of the present invention to provide programmer 60 with a video output connection to which a non-integral monitor can be connected.

Medical device programmer 60 further includes a user input device coupled to the electronic circuitry. In one embodiment, the user input device is the graphics display screen 102, which is provided with touch-sensitive capability, such that a user can interact with the programmer electronic circuitry by touching the display area on the graphics display screen 102 with a finger (not shown) or a stylus 104. In one embodiment, the touch-sensitive graphics display screen is primary input for the medical device programmer 60. The medical device programmer 60 further includes a programming head 106, which is placed over a patient's body near the implant site of an implanted device, such as CRM device 20, in order to establish a communication link between CRM device 20 and programmer 60. The telemetry link between CRM device 20 and programmer 60 allows the electronic circuitry of programmer 60 to be coupled to the electronic control circuitry of the CRM device 20. The programming head 106 is coupled to the electronic circuitry of medical device programmer 60 and a receiver circuit for receiving signals from the transmitter circuit indicative of cardiac signals by a cable 108. In one embodiment, a communication system 70 is intermediate programmer 60 and CRM device 20, for example the telephone system or a computer network such as a LAN, WAN, or global computer network (e.g. internet). Consequently, the programmer 60 remotely monitors and receives data from the CRM device 20.

In one embodiment of the invention, the stylus 104 used to interact with the touch-sensitive graphics display screen 102 is coupled to the programmer electronic circuitry within the housing 100 by a cable 110. In another embodiment of the invention, only a touch sensitive screen 102 is provided which is activated by a user's finger touching the screen. Alternatively, medical device programmer 60 may be equipped with a conventional computer "mouse"-type pointing device, rather than a stylus or a touch sensitive screen which is actuatable by a user's finger. In the absence of either a stylus, touch-sensitive screen or a mouse, on-screen cursor control for enabling user interaction with medical device programmer 60 may be facilitated through cursor control keys 112 (arrow keys or the like) disposed on medical device programmer 60.

Medical device programmer 60 further includes a receiver circuit for receiving signals from the transmitter circuit indicative of cardiac signals. Through the communication link with CRM device 20, the medical device programmer 60 is capable of capturing and storing recorded data transmitted from CRM device 20 and displaying the data on its graphics display screen 102. Programmer 60 compiles data into numerous forms for display on graphics display screen 102, such forms include charts and graphs, for example those shown in FIGS. 5-11. The programmer 60 may also include other forms of display and output devices such as printers and plotters. Moreover, programmer 60 can store the downloaded data and build a database containing the

patient's therapy and health data, which can be downloaded to known computer readable media for long term storage.

In one embodiment, programmer 60 downloads the data it receives from CRM device 20 to a computer system 80 (FIG. 3) via a communication path. Computer system 80 includes memory for storing the downloaded data, a processor and associated software for correlating the data, and a display device for displaying the correlated data. Display devices include display screens, monitors, printer, plotters, etc. It will be understood that all the data correlating and data display functions described herein as being performed by programmer 60 are also performable by computer system 80, but for simplicity of explanation the following description refers to programmer 60.

While the above describes one embodiment of a medical system in which the present invention can be incorporated, it will be understood that the present invention can be incorporated into numerous CRM devices and programmers. Therefore, it will be understood by those of skill in the art that the present invention can be adapted for use with other types of CRM devices, examples of such devices are found in U.S. Pat. Nos. 6,112,117; 6,108,577; 6,091,990; 6,076,015; 6,067,471; 6,016,446; and 5,978,707, all assigned to the present assignee, and all herein incorporated in their entirety by reference. It will also be understood by those of skill in the art that the present invention can be adapted for use with other types of programmers.

FIG. 4 shows a flow chart representing one embodiment of a process for producing and displaying two distinct sets of data. The CRM device programmable parameters are stored in CRM memory 56 (410), for example by the programmer 60 communicating the selected parameters via a communication link. CRM device 20 provides therapy to a patient and records various health data, for example tachy episodes, brady episodes, maximum heart rate, minimum heart rate, mean heart rates, heart rate variability, patient activity, blood pressure, etc. (415). The CRM device 20 also records its system parameters at the time it makes certain patient health measurements. In another embodiment of CRM device 20, it stores other therapy data, such as drug therapy data, which is not delivered or measured by CRM device 20. During a clinical visit by a physician, CRM device 20 downloads recorded data to the programmer 60 (420). At this time programmer 60 may include previously downloaded patient health data and CRM device parameters from previous patient therapies and add the newly downloaded information to a patient record stored in a database. The physician now selects two different sets of patient/CRM device data to display, for example on graphics display 102 of programmer 60 (425). The programmer 60 correlates the two different data sets (430). For example, if the two data sets are patient activity and a CRM device parameter change, then programmer 60 graphs patient activity before and after the CRM device parameter change. The programmer 60 displays the correlated data sets. Thus, a physician can readily visually comprehend the effect the data sets have on each other or a change in patient health. In the above example, the physician can visualize the effect the CRM device parameter change had on patient activity.

FIG. 5 shows an embodiment of a graph produced by programmer 60 and displayed on graphical display 102. The FIG. 5 graph displays selected patient health data represented on the Y-axis and time represented on the X-axis with selected asynchronous data superimposed on the graph. In an embodiment, the patient health data is periodically collected over time. In another embodiment, the data is continuous data. The selected patient health data for a time

period between time t_0 and time t_1 is graphically displayed as shown in FIG. 5. At time t_1 , an event 510 in the patient's therapy occurs and is graphically displayed. Here, the event is shown as a line but other representations are within the scope of the invention. This event can include, but is not limited to, changes in the CRM device parameters and patient's medications. In the area of the graph between time t_1 and time t_2 , the selected patient health information is displayed which represents the patient health data after event 510. As a result of graphing both the patient health data and the event 510, the physician can quickly visualize the effect, if any, event 510 had on the patient health data by comparing the graphical display before the event (area between t_0 and t_1) with the graphical display after event (area between t_1 and t_2). In an embodiment, the event 510 can be labeled such that the physician will be informed upon viewing the display what the event 510 is. Such a label can be a indicia adjacent the line indicating event 510 or a legend outside the graph such that the data in the graph is not obscured.

FIG. 5 further shows that the present invention can include multiple events 510 and 520 on a single graph of the selected patient health data versus time. As a result, the area of the graph between time t_1 and time t_2 graphically displays the patient health data after first event 510 and before second event 520. The area of the graph after time t_2 graphically displays the patient health data after second event 520. The physician can now ascertain the effect the events 510 and 520 had on patient's health which is represented by the selected patient health data on the Y-axis. Events 510 and 520 can represent the same type of event, for example, changes in accelerometer response factor, lower rate limit, brady pacing parameters, etc. Events 510 and 520 can also represent two different type of events such the graph shows the effect on the patient health data of the first event 510 and the effect on the patient health data of the different, second event 520, such as a drug therapy change or a programmed parameter change in CRM device 20.

Specific examples of the graphs produced by the described embodiment of the system will now be described in conjunction with FIGS. 6-8. As discussed above, CRM device 20 records therapy history and numerous patient health data sets and downloads same to programmer 60. The recorded therapy history includes the number of electrical shocks administered by the CRM device to the patient's heart. The programmer, when instructed by the physician to do so, for example by touching display screen 102 with stylus 104, graphs the number of shocks delivered in discrete time periods ($t_1, t_2, t_3, \dots, t_n$), for example in a day, week, etc., versus time, for example, week, month, etc. (FIG. 6). In the displayed time period at time t_4 , the ventricular sensitivity of CRM device 20 was changed. This change in ventricular sensitivity is represented by a cross hatched vertical bar 610 whereas the number of shocks administered at the time intervals are displayed in a different format, here non-crosshatched vertical bars. Moreover, the bar 610 represents that the change in ventricular sensitivity occurred during the time period in which the data represented thereby was recorded. Specifically, if bar 610 represents a weeks worth of data, then the ventricular sensitivity change occurred during that week. As a result, the FIG. 6 graph shows the number of shocks administered by the CRM device over time t_0 to time t_4 at a first ventricular sensitivity and the number of shocks administered by the CRM device over time t_4 to time t_n at a second ventricular sensitivity with a visual indicator showing when the change in ventricular sensitivity occurred.

In another embodiment, different representations of bar 60, for example different colors, hatching, etc., represent when the change in ventricular sensitivity occurred. In one embodiment, vertical hatching of bar 610 represents changing ventricular sensitivity (second data) after the number of shocks (first data) were recorded. In one embodiment, horizontal hatching of bar 610 represents changing ventricular sensitivity (second data) before the number of shocks (first data) were recorded. Accordingly, the physician can visualize the effect the change in ventricular sensitivity had on the number of shocks administered to the patient's heart. In the illustrated embodiment of FIG. 6, the effect the change in ventricular sensitivity 610 had was to reduce the number of shocks administered to zero. If additional shocks occurred, then the data bars, in one embodiment, occurring after time t_4 would also be cross hatched so that the displayed data readily indicates data that was recorded before and after a change in another data, here ventricular sensitivity. In another embodiment, the first data recorded before the event represented by the second data is displayed in a first color and the first data recorded after the event represented by the second data is shown in a second color.

Therapy history as stored in memory 56 of CRM device 20 and downloaded to programmer 60 further includes patient activity data and which chambers of the patient's heart required pacing at specific times. Patient activity data is a measurement of the percent of a fixed time period, e.g. a day, at which a patient reaches an activity threshold, e.g. time patient has a heart rate above a predetermined threshold value such as beats per minute threshold value. The programmer, when instructed by a physician to do so, displays a graph of the patient's activity versus time (FIG. 7). The physician has also instructed the programmer 60 to display the pacing chamber performance of CRM device 20. Here, the FIG. 7 graph shows the pacing chamber to be both ventricles (BV), right ventricle (RV), or left ventricle (LV). The physician can visualize the relationship of the patient's activity with the CRM device's pacing chamber activity.

FIG. 8 shows a graph produced by programmer 60 which also displays patient activity versus time but unlike FIG. 7 the second data type displayed is when a change in accelerometer response factor occurred. The change in accelerometer response factor is indicated at 810 in FIG. 8 by a vertical bar. Accordingly, the physician can visualize the effect changing the accelerometer response factor had on the patient activity as measured by CRM device 20 by comparing the area of the graph to the left of bar 810 with the area of the graph to the right of bar 810.

FIGS. 9-11 show displays of various types of data associated with a patient and the CRM device. The displays are produced by programmer 60, for example on screen 102, or by a display device that interacts with the programmer 60.

FIG. 9 shows two graphs 910, 920 of the same type of data, namely, heart rate variability, but the data shown on the graphs was recorded under distinct conditions, namely, two different periods of time. The conditions 915, 925 at which each set of heart rate variability data was recorded is displayed adjacent each graph. This type of dual graph visually informs the physician of changes in the same type of data and the change in the conditions at which such data was recorded. Conditions at which the data was recorded include a set of parameters that are related to the data displayed in graphs 910, 920.

In the illustrated FIG. 9 embodiment, the top display is the last measured heart rate variability graph 910 and condition data 915, both recorded on a certain date and the lower display is a reference heart rate variability graph 920 and

condition data **925**, both recorded on a previous date. Each condition data display **915, 925** includes a title, here “last measured” and “reference” respectively, the date and time of data measurement, and data representing measured data and programmed parameters. The illustrated embodiment shows data that includes measured and/or calculated data such as the footprint of the accompanying graph (a measure of the non-white space in the graph), which is the percent of time heart rate variability data was gathered during the recording period, and SDANN (standard deviation of the means of all the successive 5 minutes segments contained in a whole recording). The illustrated embodiment shows data that includes programmed parameters such as pacemaker mode, the lower rate limit, the maximum tracking rate, the atrio-ventricular delay, and the pacing chamber. The physician can visually recognize differences in the patient’s heart rate variability and the changes in conditions at which the heart rate variability was acquired based on the simultaneous display of the two heart rate variability graphs **910, 920** along with the associated data **915, 925** for each graph. This allows the physician to accurately interpret the displayed data in context with associated data and/or programmed parameters.

FIG. **10** shows graphs **1010, 1020, 1030** of trend data for three different measured data sets, namely heart rate, footprint, and SDANN. Trend data is the value of a select measurement over a period of time. In the illustrated embodiment the each graph **1010, 1020, 1030** includes two sub-graphs. The first sub-graph displays the data in weekly increments. The second sub-graph displays the data according to the day of the week it was measured. The three displays and sub-graphs share the same X-axis time line and are simultaneously displayed so that a physician can easily see correlations, if any, between the displayed trend graphs. This allows the physician to accurately interpret the displayed, measured data in context with other displayed, measured data and helps provide a more accurate diagnosis.

FIG. **11** shows a further graph **1100** having the same sub-graph layout and X-axis time line as in FIG. **10**. Graph **1100** displays the percent of time that a patient is active, sometimes measured by the CRM device **20** as the time when the patient’s activity, as determined by cardiac data, is above a certain threshold value. Graph **1100** simultaneously displays two interpretations of the activity measurements. The first sub-graph, shown on the left in FIG. **11**, displays activity data over the course of a year in weekly increments. The second sub-graph, shown on the right in FIG. **11** shows the activity data as a function of the day of the week it was measured. Thus, the physician can visually determine the patient’s activity level and provide a diagnosis based on display **1100**.

It will be recognized that it is within the scope of the present invention to select the data and/or parameters simultaneously displayed so that the display will be of most use to a physician when interpreting the displayed data. For example, the activity data display **1100** could be selected to display with the heart rate trend display **1010**. Such a selection of data displays provides the physician with a tool which assists in quick and accurate interpretation of the data measured by CRM device **20** and parameters programmed into CRM device **20**. Thus, the display of data and/or parameters according to the present invention includes simultaneously displaying measured data with other measured data and events, measured data with programmable parameters, and programmable parameters with other programmable parameters. Moreover, the measured data includes both synchronous data, periodic data, and asyn-

chronous data. It will be appreciated that various combinations of data types and parameters can be simultaneously displayed.

While many of the embodiments described herein and shown in the drawings display data in a specific format, it will be understood that other formats are within the scope of the present invention. Such other formats include changing the display color, if a color display is available, or changing the grey-scale, if only a monochrome display is available, for first data before and after an event or in the presence of second data correlated to the first data. Other formats further include different cross-hatching and different line types. Nevertheless, each of the data formats provides the viewer with visual indication of a change in data or a change in the environment in which the data was recorded.

Although the invention has been described in conjunction with the foregoing specific embodiments, many alternatives, variations, and modifications will be apparent to those of ordinary skill in the art. Such alternatives, variations, and modifications are intended to fall within the scope of the following appended claims. For example, the CRM system controls a large number of programmable parameters of the CRM device and stores a large number of CRM device performance data sets and sensed patient health data. It will be understood that the above described embodiments are examples and numerous correlations of data, data and parameter, etc. are within the scope of the present invention.

What is claimed is:

1. A medical system, comprising:

an external medical device, including a signal sensing circuit coupled to one or more physiologic sensors, the signal sensing circuit configured to sense one or more physiologic signals indicative of a health condition of a patient;

a receiver circuit configured to receive, from a unit external to the external medical device, therapy data for a therapy delivered to the patient by a device other than the external medical device, the therapy data including a therapy type or a parameter of the delivered therapy;

a memory circuit in communication with the signal sensing circuit and the receiver module, the memory circuit configured to store a plurality of data sets including at least a first data set distinct from a second data set, the first and second data sets each including one of the therapy data or the one or more physiologic signals;

a processor connected to the memory circuit, the processor adapted to correlate the first data set and the second data set; and

an output unit coupled to the processor, the output unit configured to receive the correlated first and second data sets from the processor, and to simultaneously display the first and second data sets over a specified period on the output unit.

2. The system of claim **1**, wherein the external medical device is configured to monitor cardiac function of the patient.

3. The system of claim **2**, wherein the external medical device comprises external cardiac electrodes.

4. The system of claim **1**, wherein the signal sensing circuit is configured to sense electrical activity from at least one of a ventricle or an atrium of a heart.

5. The system of claim **1**, wherein the signal sensing circuit is coupled to an accelerometer configured to sense an activity level of the patient.

6. The system of claim **1**, wherein the receiver circuit is configured to receive therapy data associated with an application of a drug therapy.

13

7. The system of claim 1, wherein the receiver circuit is configured to receive therapy data associated with an application of electrical therapy delivered by a device other than the external medical device.

8. The system of claim 1, wherein the receiver circuit is configured to receive therapy parameters associated with delivery of the therapy.

9. The system of claim 1, comprising a transmitter circuit operable over a communication network, wherein:

the transmitter is configured to transmit at least the first and second data sets over the communication network; the processor is adapted to receive over the communication network and to correlate the first and second data sets; and

the communication network includes at least one of a telephone network, a computer network, or an internet.

10. The system of claim 1, wherein the memory circuit is further configured to store at least one of a change in therapy, a change in context, a medical event and another physiological parameter.

11. The system of claim 1, wherein the processor is adapted to correlate the sensed physiologic signal and the received therapy data.

12. The system of claim 11, wherein the output unit is configured to display a visual indicator indicating an effect of the therapy on the sensed physiologic signal.

13. A medical system, comprising:

an external medical device, including a signal sensing circuit coupled to one or more physiologic sensors, the signal sensing circuit configured to sense one or more physiologic signals indicative of a health condition of a patient, wherein the external medical device comprises external cardiac electrodes;

a receiver circuit configured to receive, from a unit external to the external medical device, therapy data for a therapy delivered to the patient by a device other than the external medical device, the therapy data including a therapy type or a parameter of the delivered therapy;

a memory circuit in communication with the signal sensing circuit and the receiver circuit, the memory circuit configured to store a plurality of data sets including at least a first data set distinct from a second data set, the first and second data sets each including one of the therapy data or the one or more physiologic signals;

an external data processor and monitor system configured to communicate with the external medical device, the external data processor and monitor system including:

14

a processor adapted to receive the first and second data sets from the external medical device, and to correlate the first and second data sets; and

an output unit coupled to the processor, the output unit configured to receive the correlated first and second data sets from the processor, and to simultaneously display the first and second data sets over a specified period on the output unit.

14. A method for operating a medical system for monitoring a health condition of a patient, the method comprising:

sensing one or more physiologic signals from the patient using an external medical device;

receiving, from a unit external to the external medical device, therapy data for a therapy delivered to the patient by a device other than the external medical device, the therapy data including a therapy type or a parameter of the delivered therapy;

storing in a memory circuit a plurality of data sets including at least a first data set distinct from a second data set;

correlating the first data set to the second data set; transmitting the correlated first and second data sets to an output unit; and

displaying at least the correlated first and second data sets.

15. The method of claim 14, wherein sensing the one or more physiologic signals includes sensing electrical activity from at least one of a ventricle or an atrium of a heart.

16. The method of claim 14, wherein sensing the one or more physiologic signals includes sensing an activity level of the patient.

17. The method of claim 14, wherein receiving the therapy data includes receiving therapy parameters associated with one of a drug therapy or an electrical therapy.

18. The method of claim 14, wherein transmitting the correlated first and second data sets includes transmitting the data sets over at least one of a telephone network, a computer network, or an internet.

19. The method of claim 14, wherein displaying the correlated first and second data sets includes: displaying the sensed physiologic signal, including displaying parameters used for sensing the physiologic signal; and displaying the received therapy data, including displaying therapy parameters associated with delivery of the therapy.

20. The method of claim 14, wherein displaying the correlated first and second data sets includes displaying a visual indicator indicating a change in the first data set occurring after an event occurring in the second data set.

* * * * *

专利名称(译)	用于关联患者健康信息和设备数据的系统和方法		
公开(公告)号	US9949687	公开(公告)日	2018-04-24
申请号	US15/387009	申请日	2016-12-21
[标]申请(专利权)人(译)	心脏起搏器股份公司		
申请(专利权)人(译)	心脏起搏器, INC.		
当前申请(专利权)人(译)	心脏起搏器, INC.		
[标]发明人	KALGREN JAMES R WENTKOWSKI RENE H STAHMANN JEFFREY E		
发明人	KALGREN, JAMES R. WENTKOWSKI, RENE H. STAHMANN, JEFFREY E.		
IPC分类号	A61N1/00 A61B5/044 A61N1/39 A61B5/00 A61B5/11 A61N1/37		
CPC分类号	A61B5/4848 A61B5/0006 A61B5/0022 A61B5/044 A61N1/3956 A61B5/7246 A61B5/742 A61N1/3702 A61B5/1118 A61B5/743 A61B5/7445 A61N1/3993		
优先权	14/480962 2015-10-13 US 13/964893 2014-09-16 US 13/411063 2013-10-01 US 12/941377 2012-03-06 US 11/379912 2010-11-30 US 10/687433 2006-05-16 US 09/738869 2003-12-16 US		
其他公开文献	US20170100074A1		
外部链接	Espacenet USPTO		

摘要(译)

一种用于显示健康相关数据的系统和方法。该系统包括记录数据的医疗设备和显示生成设备，该显示生成设备使数据相关并且同时显示不同类型的的数据或显示两组相同类型的数据以及两组数据被记录的环境。这种显示器有助于医师开处方和确定心脏疗法的功效。

