



US 20180333204A1

(19) **United States**

(12) **Patent Application Publication**
NG

(10) **Pub. No.: US 2018/0333204 A1**

(43) **Pub. Date: Nov. 22, 2018**

(54) **APPARATUS AND METHOD OF ASSESSING
TRANSVASCULAR DENERVATION**

(71) Applicant: **St. Jude Medical, Inc.**, St. Paul, MN
(US)

(72) Inventor: **Kok-Hwee NG**, Irvine, CA (US)

(21) Appl. No.: **16/018,577**

(22) Filed: **Jun. 26, 2018**

2018/00642 (2013.01); A61B 2018/00577
(2013.01); A61B 2018/00511 (2013.01); A61B
2018/00434 (2013.01); A61B 2018/00404
(2013.01); A61B 2018/00345 (2013.01); A61B
2018/00267 (2013.01); A61B 2018/00226
(2013.01); A61B 2018/0022 (2013.01); A61B
2018/0016 (2013.01); A61B 5/6885 (2013.01);
A61B 5/04001 (2013.01); A61B 2090/064
(2016.02); A61B 2018/1475 (2013.01); **A61B**
5/0215 (2013.01)

Related U.S. Application Data

(63) Continuation of application No. 14/537,109, filed on
Nov. 10, 2014, which is a continuation of application
No. 13/153,838, filed on Jun. 6, 2011, now Pat. No.
8,909,316, which is a continuation-in-part of appli-
cation No. 13/110,041, filed on May 18, 2011, now
abandoned.

Publication Classification

(51) **Int. Cl.**

A61B 18/14 (2006.01)
A61B 5/0215 (2006.01)
A61B 5/00 (2006.01)
A61B 18/00 (2006.01)
A61B 5/04 (2006.01)
A61B 90/00 (2016.01)

(52) **U.S. Cl.**

CPC **A61B 18/1492** (2013.01); **A61B 2018/00839**
(2013.01); **A61B 5/6853** (2013.01); **A61B**
2018/00702 (2013.01); **A61B 2018/00678**
(2013.01); **A61B 2018/00672** (2013.01); **A61B**

(57)

ABSTRACT

A catheter apparatus for assessing denervation comprises: an elongated catheter body; a deployable structure coupled to the catheter body, the deployable structure being deployable outwardly from and contractible inwardly toward the longitudinal axis of the catheter body; one or more ablation elements disposed on the deployable structure to move outwardly and inwardly with the deployable structure; one or more stimulation elements spaced from each other and disposed on the deployable structure to move with the deployable structure, the stimulation elements being powered to supply nerve stimulating signals to the vessel; and one or more recording elements spaced from each other and from the stimulation elements, the recording elements being disposed on the deployable structure to move with the deployable structure, the recording elements configured to record response of the vessel to the nerve stimulating signals.

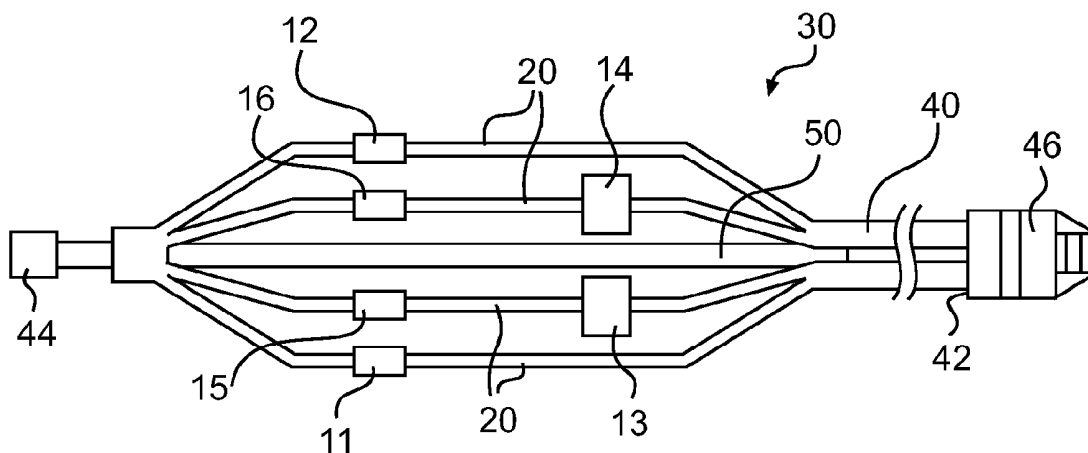

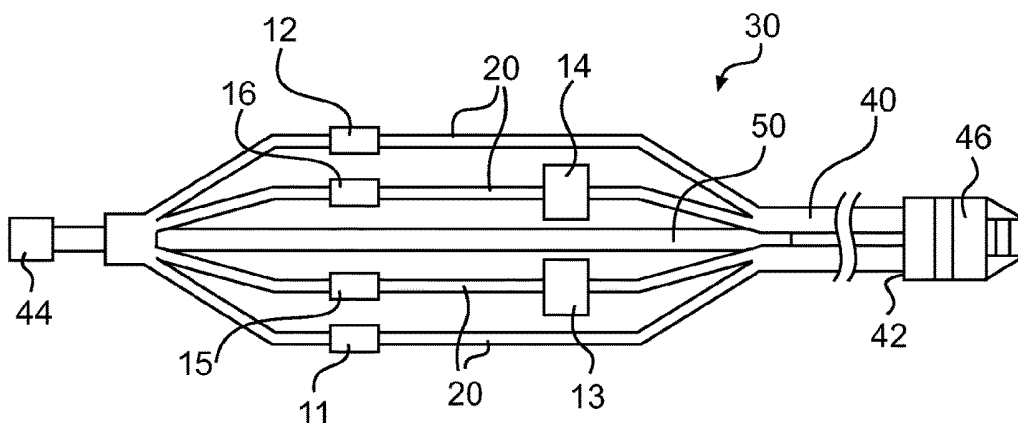

FIG. 1

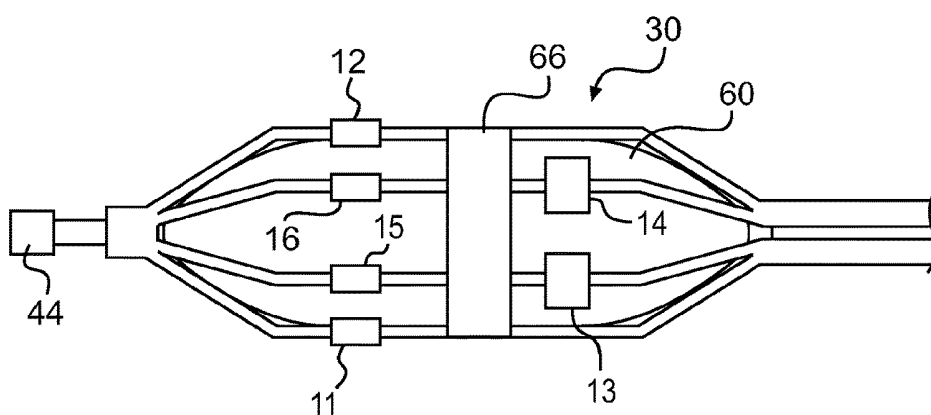

FIG. 2

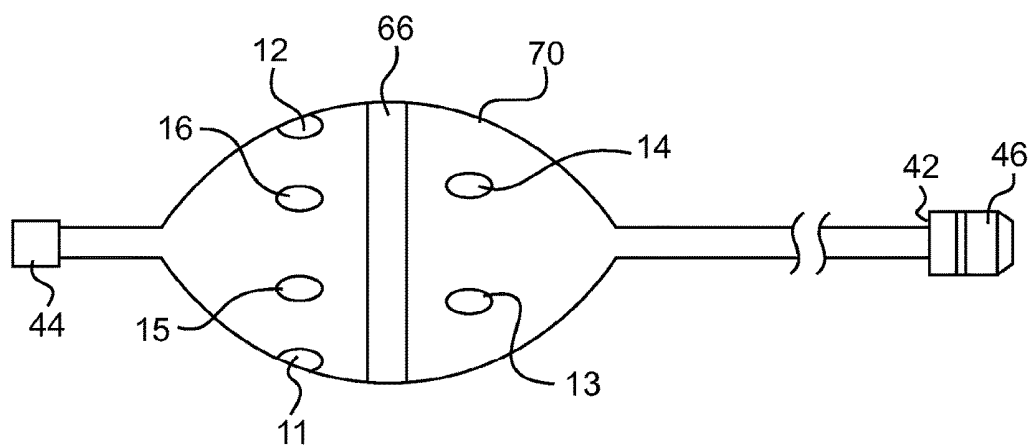

FIG. 3

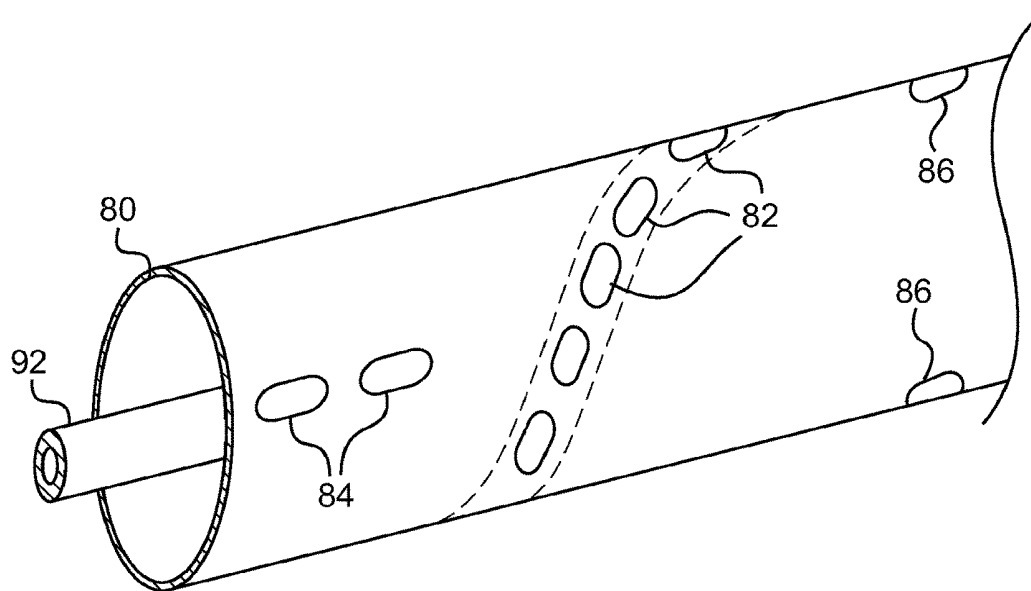

FIG. 4

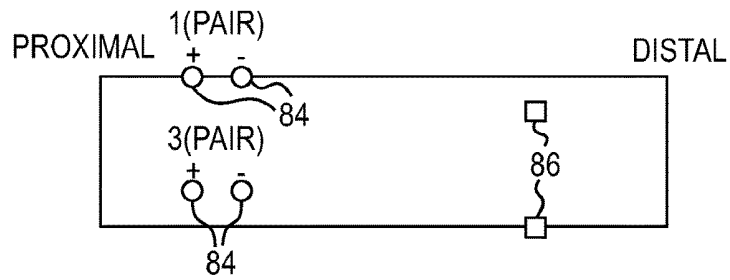

FIG. 5A

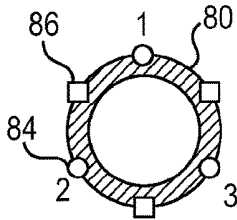

FIG. 5B

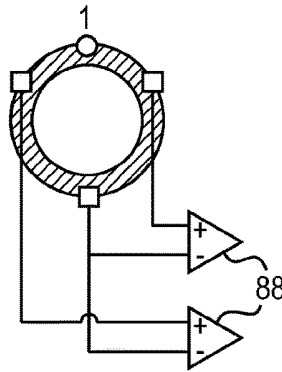

FIG. 5C

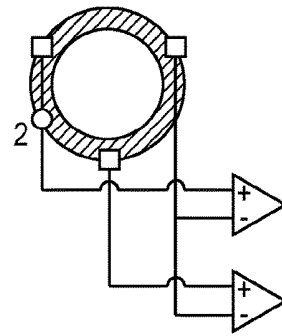

FIG. 5D

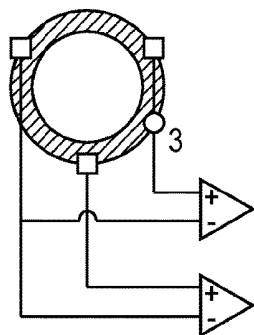

FIG. 5E

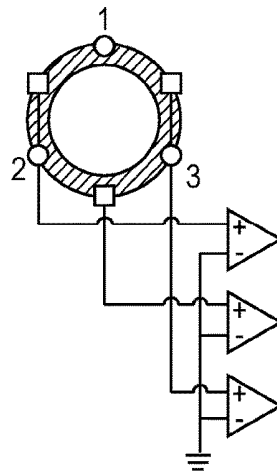

FIG. 5F

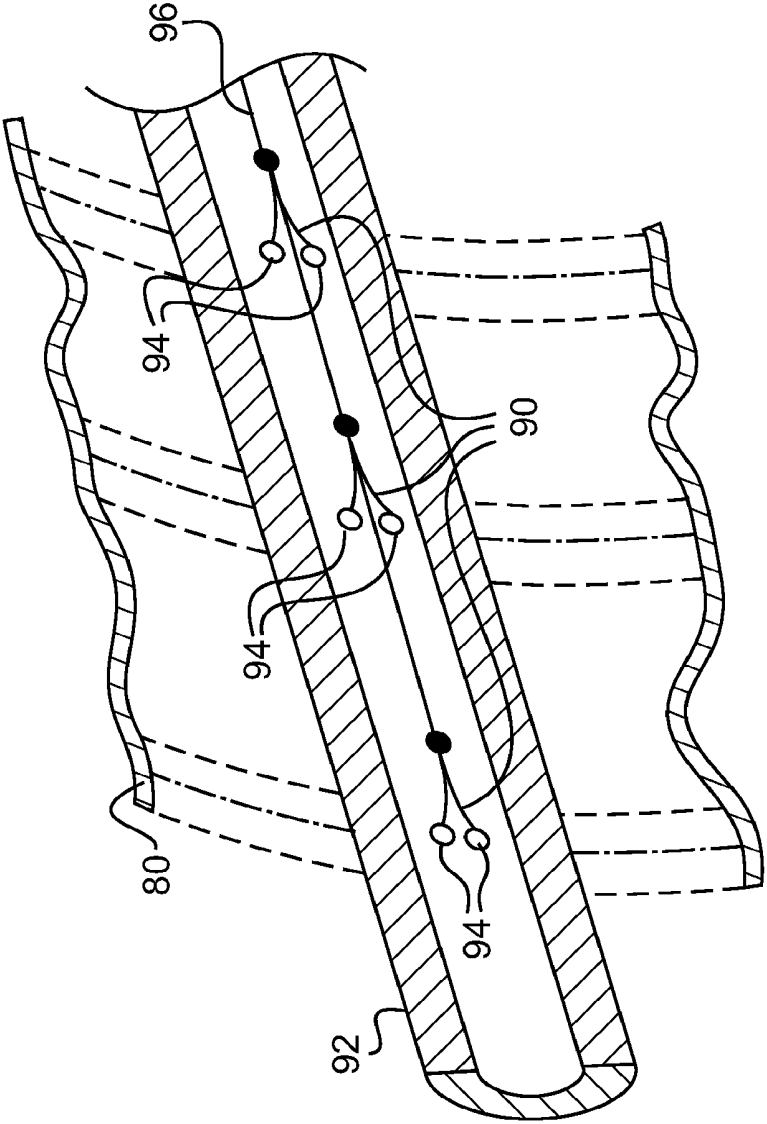

FIG. 6

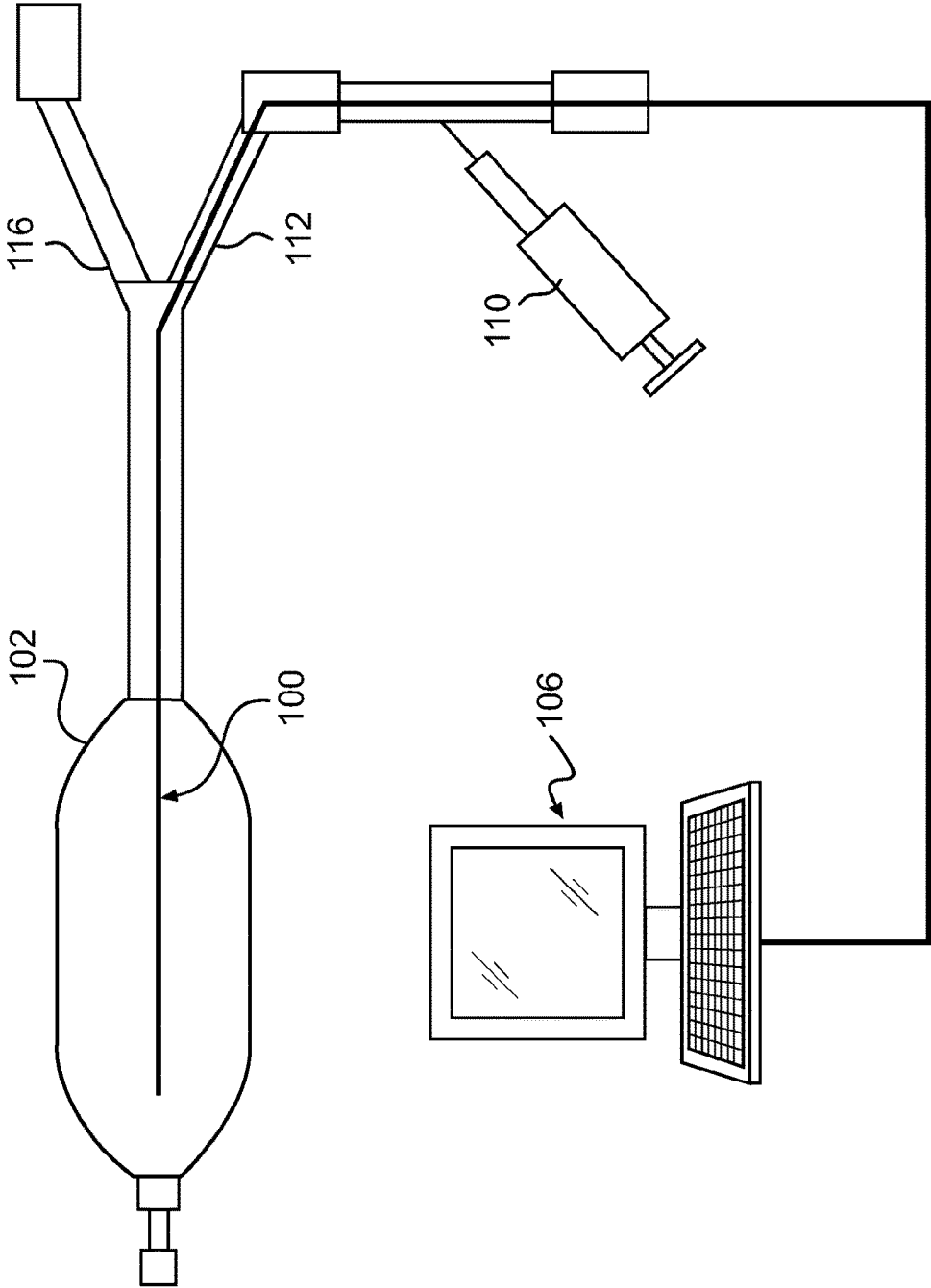

FIG. 7

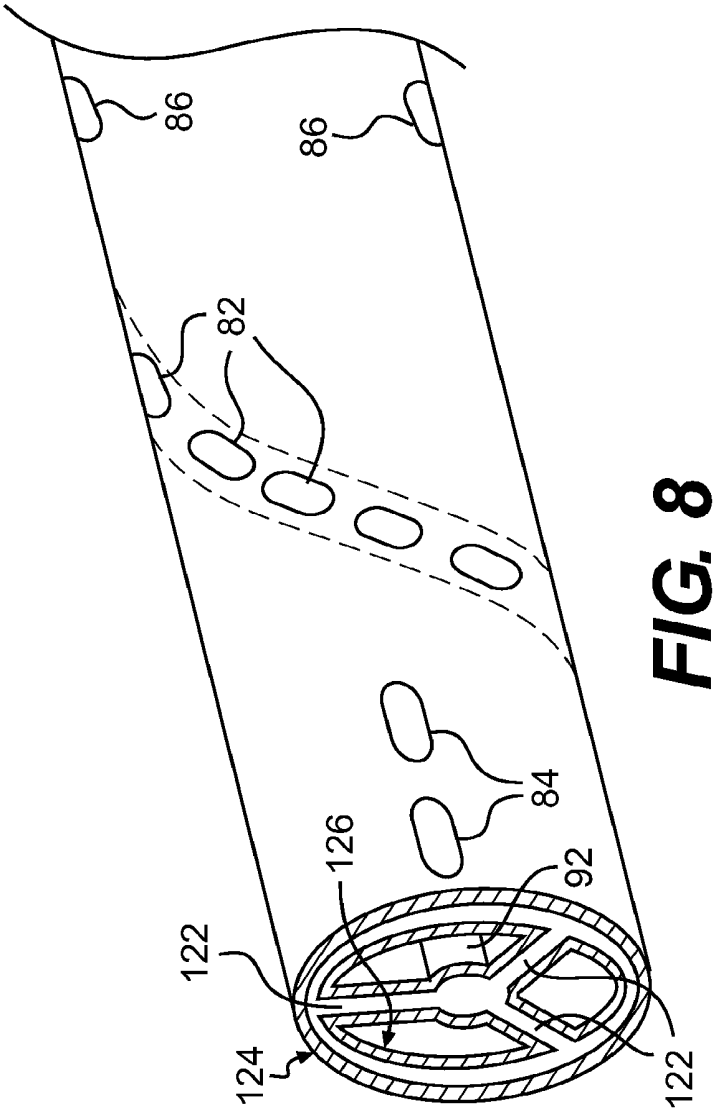

FIG. 8

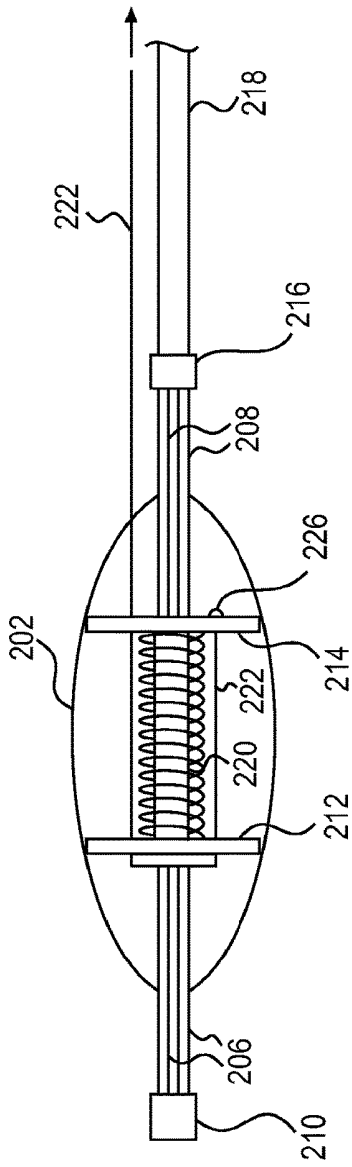

FIG. 8A

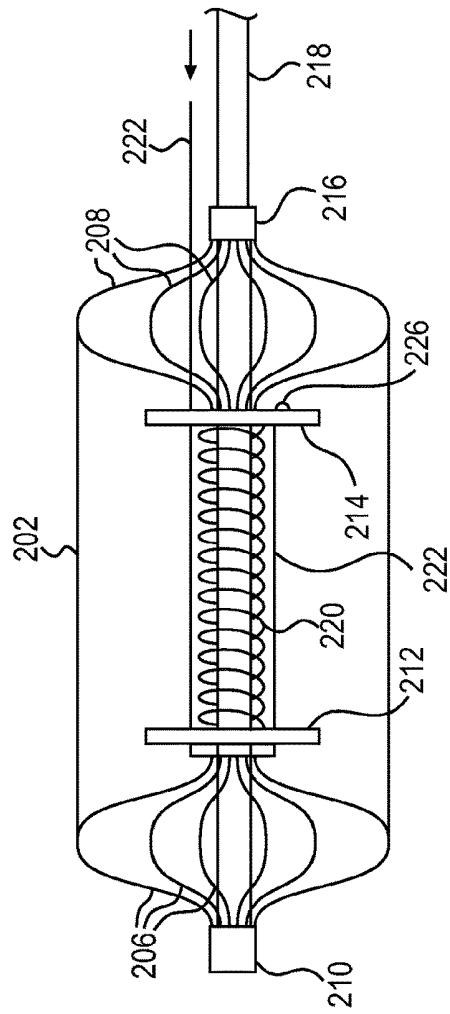

FIG. 8B

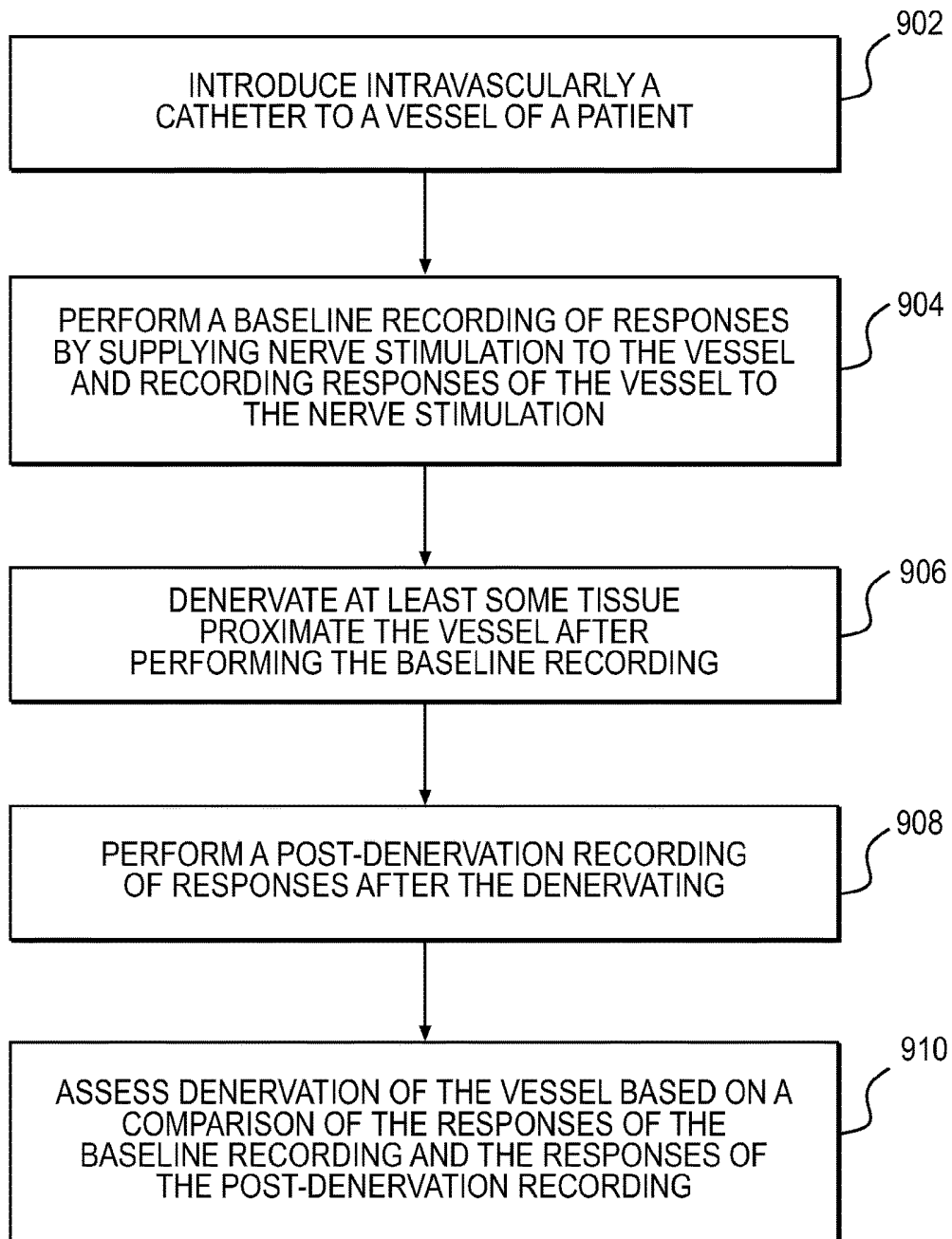
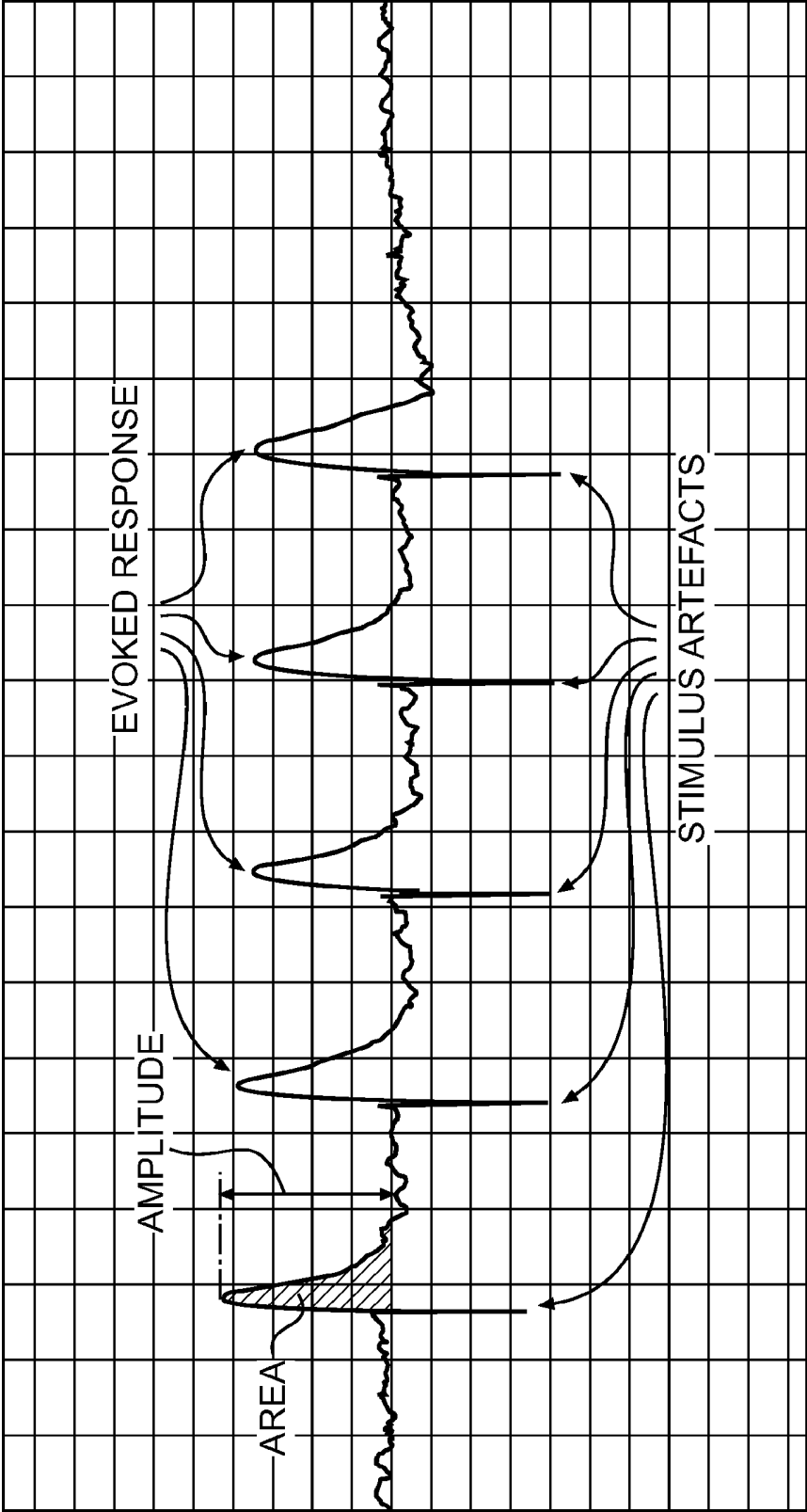

FIG. 9



SECONDS

FIG. 10

APPARATUS AND METHOD OF ASSESSING TRANSVASCULAR DENERVATION

RELATED APPLICATIONS

[0001] This application is a continuation of U.S. patent application Ser. No. 14/537,109, filed Nov. 10, 2014, which is a continuation of U.S. patent application Ser. No. 13/153,838, filed Jun. 6, 2011, issued as U.S. Pat. No. 8,909,316, which is a continuation-in-part of U.S. patent application Ser. No. 13/110,041, filed May 18, 2011, each of which are incorporated herein by reference in their entireties.

BACKGROUND OF THE INVENTION

[0002] The present invention relates generally to catheter devices, and more specifically to catheter devices for assessing transvascular denervation.

[0003] Renal denervation is a method whereby amplified sympathetic activities are suppressed to treat hypertension or other cardiovascular disorders and chronic renal diseases. The objective of renal denervation is to neutralize the effect of renal sympathetic system which is involved in arterial hypertension. The following describes some examples of renal denervation devices. U.S. Pat. No. 7,653,438 discloses renal neuromodulation using a pulsed electric field to effectuate electroporation or electrofusion. It describes percutaneous intravascular delivery of pulsed electric fields to achieve renal neuromodulation. U.S. Patent Application Publication No. 2010/0268307 discloses intravascularly induced neuromodulation using a pulsed electric field to effectuate irreversible electroporation or electrofusion, necrosis, and/or inducement of apoptosis, alteration of gene expression, changes in cytokine upregulation, etc., in target neural fibers. It mentions the use of the technique to modulate a neural fiber that contributes to renal function. International Patent Publication No. WO2008/092246 discloses transvascular nerve stimulation through the walls of blood vessels. It uses electrodes supported on an electrically insulating backing sheet and a structure for holding the backing sheet against the inner wall of the blood vessel.

[0004] Catheters are flexible, tubular devices that are widely used by physicians performing medical procedures to gain access into interior regions of the body. A catheter device can be used for ablating renal sympathetic nerves in therapeutic renal sympathetic denervation to achieve reductions of blood pressure in patients suffering from renal sympathetic hyperactivity associated with hypertension and its progression. See, e.g., Henry Krum et al., Catheter-Based Renal Sympathetic Denervation for Resistant Hypertension: A Multicentre Safety and Proof-of-Principle Cohort Study, published online Mar. 30, 2009 at www.thelancet.com.

[0005] Renal arteries, like all major blood vessels, are innervated by perivascular sympathetic nerves that traverse the length of the arteries. The perivascular nerves consist of a network of axons, terminals, and varicosities, which are distributed mostly in the medial-adventitial and adventitial layers of the arterial wall. The medial and adventitial layers of the renal artery consist mostly of vascular smooth muscle cells (VSMCs), while the intimal layer is made up of endothelial cells (ECs). A small percentage of the VSMCs in the adventitia of the renal artery have a direct coupling to the varicosities because of their proximity to each other. When the renal sympathetic nerve is stimulated and an action potential travels along the axon, all varicosities along the

axon are depolarized and neurotransmitters are released into the junctions of directly-coupled VSMCs. This event causes the opening of specific ionic and second messenger molecule channels of the VSMCs and results in their depolarization.

[0006] The depolarization described above would normally be confined to the first layer of the VSMCs that are directly coupled to the varicosities because extracellular diffusion of neurotransmitters is characterized by a small space and time constant. Therefore in theory any recording of excitatory junction potentials (EJPs) should be done at the directly coupled VSMCs. However, numerous studies of vasomotion of arteries have led to the understanding that additional VSMCs are recruited in generating a syncytial response to neural stimulation. Thus gap junctions have been identified amongst VSMCs and ECs, and between VSMCs and ECs. These gap junctions form the conduit for intercellular communication and facilitate neurotransmitter diffusion over a larger space constant than can be accounted for by extracellular diffusion alone. Intercellular diffusion is dependent on gap junction permeability and decays as it crosses each junction. Recording of EJPs have been shown to take place within a few millimeters from perivascular nerves.

[0007] EJP recordings are commonly performed using intracellular techniques. The recording electrodes are typically made of glass micropipettes that impale a single cell to provide an isolated signal path to an amplifier. In other techniques, suction is applied to provide a high impedance seal between the glass micropipette and cell membrane without having to penetrate the cell. The high impedance seal isolates signal conduction between the cell membrane and the electrode from environmental noise. Extracellular recording of junction potentials are possible but more challenging because of the much smaller potential amplitude at the surface of the cell and the electronics requirements for noise reduction. Depending on the size of the recording electrode, extracellular recording may record from a single cell or an ensemble of cells. The latter is analogous to field potential recording from multi-neurons in the brain.

[0008] In certain animal arteries such as rat tail arteries and mesenteric arteries, recording of spontaneous EJPs (SEJPs) have been reported. These SEJPs occur asynchronously following normal sympathetic activities of the animal physiology. On average the recording of these asynchronous SEJPs will cancel out within a field potential recording technique, regardless of the fidelity of the recording electronics. On the other hand, when perivascular nerves are stimulated under external control, EJPs occur synchronously with the stimulus source, thus enabling evoked responses to be detected in the recording. Common techniques for electrical perivascular nerve stimulation include both nerve trunk stimulation and transmural (field) stimulation. Both techniques require direct electrode access to the adventitial area of the artery. With transmural stimulation, the stimulus strengths are designed to be supramaximal to activate the perivascular nerves without directly stimulating the VSMCs.

[0009] Transvascular technique of electrical stimulation of perivascular nerves is not as widely reported. One possible explanation is the stimulus strength required to activate the perivascular nerves will most likely also stimulate the VSMCs directly (this is because the electrical current density from the electrode attenuates as a function of distance and the VSMCs are closer to the stimulating electrodes than

the perivascular nerves), thus making it difficult to analyze neurally evoked responses independently. Most electrical stimulus consists of square pulses and by using shorter pulse widths it may be possible to selectively activate the perivascular nerves only. However, a better method is to make use of the anisotropy of VSMCs and the finite space constants of EJPs to differentiate neurally evoked responses from field evoked responses, so that perivascular nerve integrity can be independently assessed. Thus in a preferred arrangement, the stimulating electrodes and recording electrodes should be separated by a distance greater than the EJP space constant in the longitudinal direction of the vessel. In this way, the recording electrodes will only record EJPs evoked by action potentials traveling distally along the axon, while excluding EJPs evoked in the vicinity of the stimulating electrodes.

BRIEF SUMMARY OF THE INVENTION

[0010] Prior denervation devices do not provide any means of predicting the long term outcome of the renal denervation therapies. Nor do they provide a marker to assess the completeness of the therapeutic procedure. In the case where denervation is carried out by delivering continuous RF energy through the vascular wall, the typical target procedural parameters are impedance, elapsed time, temperature or power, or a combination of all the above. The correlation of these parameters with the extent of denervation has never been shown, and may not be tenable given the heterogeneous nature of vascular innervation structures. There is therefore a need to provide a more direct technique of measuring residual neural activities following denervation in order to assess the completeness of such procedures.

[0011] Exemplary embodiments of the invention provide catheter devices for assessing transvascular denervation. The patency of the innervation of vessels can be assessed directly through electrophysiological techniques. Specifically, appropriately positioned sensors are deployed in direct contact with the vessel luminal wall to record evoked responses from external stimulus. Excitatory junctional potentials from the VSMCs can be recorded. Mechanical responses (vasoconstriction or vasodilation) associated with these neural events can also be monitored. By comparing the pre-treatment recording with post-treatment recording, a DeNervation Assessment index (DNAi) can be derived.

[0012] In accordance with an aspect of the present invention, a catheter apparatus for assessing denervation comprises: an elongated catheter body having a proximal end and a distal end, a longitudinal axis extending in a longitudinal direction between the distal end and the proximal end; a deployable structure coupled to the catheter body, the deployable structure being deployable outwardly from the longitudinal axis and contractible inwardly toward the longitudinal axis of the catheter body; one or more ablation elements disposed on the deployable structure to move outwardly and inwardly with the deployable structure, the one or more ablation elements being powered to apply ablation energy to a vessel of a patient; one or more stimulation elements spaced from each other and disposed on the deployable structure to move outwardly and inwardly with the deployable structure, the one or more stimulation elements being powered to supply nerve stimulating signals to the vessel; and one or more recording elements spaced from each other and from the one or more stimulation elements, the one or more recording elements being dis-

posed on the deployable structure to move outwardly and inwardly with the deployable structure, the one or more recording elements configured to record response of the vessel to the nerve stimulating signals.

[0013] In some embodiments, the one or more stimulation elements are proximal relative to the one or more recording elements. A most distal ablation element of the one or more ablation elements is no more distal than at least one of the stimulation elements and a most proximal ablation element of the one or more ablation elements is no more proximal than at least one of the one or more recording elements. At least one of the ablation elements is also a stimulation element or a recording element. Some of the one or more recording elements are spaced from one of the one or more stimulation elements by one of a longitudinal spacing, a lateral spacing, or a combined longitudinal and lateral spacing. The one or more recording elements are configured to record one or more of evoked electrical responses or mechanical responses of the vessel in response to the nerve stimulating signals.

[0014] In specific embodiments, the deployable structure comprises a plurality of longitudinal spines, each of the spines having a proximal end connected to the catheter body and a distal end connected to the catheter body. Each spine includes an elbow having at least one discontinuity in stiffness at an intermediate position between the distal end and the proximal end thereof. The one or more ablation elements, the one or more stimulation elements, and the one or more recording elements are disposed on the spines. The deployable structure is contractible to a contracted arrangement to fit within a lumen of the elongated catheter body and is deployable to a deployed arrangement with the elbows of the spines bending outwardly relative to the proximal and distal ends of the spines, the elbows of the spines moving radially outwardly from the contracted arrangement to the deployed arrangement. The catheter apparatus further comprises a balloon disposed inside the deployable structure, the spines being disposed radially outwardly relative to the balloon, the balloon inflating to move the spines radially outwardly in the deployed arrangement and deflating in the contracted arrangement. One or more contact sensors are disposed on a surface of the balloon for measuring force or pressure.

[0015] In some embodiments, the deployable structure comprises a balloon made of an electrically insulative material, the balloon inflating to move radially outwardly relative to the catheter body in a deployed arrangement and deflating in an undeployed arrangement. The one or more ablation elements, one or more stimulation elements, and one or more recording elements are disposed on a surface of the balloon. An intraluminal pressure sensor is to be introduced and deployed inside the balloon for pressure monitoring.

[0016] In specific embodiments, the deployable structure comprises a deployable sleeve made of an electrically insulative material and a hollow tubing disposed inside the deployable sleeve. The hollow tubing includes a plurality of holes for fluid to pass therethrough to push the deployable sleeve radially outwardly relative to the catheter body in a deployed arrangement. The one or more ablation elements, the one or more stimulation elements, and the one or more recording elements are disposed on a surface of the deployable sleeve. The catheter apparatus further comprises a plurality of draw strings extending from inside the hollow tubing through the holes to the deployable sleeve to draw the

deployable sleeve radially inwardly relative to the catheter body in an undeployed arrangement. The deployable structure is contractible to a contracted arrangement and is deployable to a deployed arrangement. The deployable structure includes an anti-occlusion feature to permit fluid flow in the vessel between a proximal end and a distal end of the deployable structure in the deployed arrangement.

[0017] In accordance with another aspect of the invention, a catheter apparatus for assessing denervation comprises: an elongated catheter body having a proximal end and a distal end, a longitudinal axis extending in a longitudinal direction between the distal end and the proximal end; a structure coupled to the catheter body; one or more ablation elements disposed on the structure and being powered to apply ablation energy to a vessel of a patient; one or more stimulation elements spaced from each other and disposed on the structure, the one or more stimulation elements being powered to supply nerve stimulating signals to the vessel; one or more recording elements spaced from each other and from the one or more stimulation elements, the one or more recording elements being disposed on the structure and configured to record response of the vessel to the nerve stimulating signals; and a mechanism to deploy the structure outwardly from the longitudinal axis of the catheter body to move the ablation elements, the one or more stimulation elements, and the one or more recording elements outwardly to a deployed arrangement, and to contract the structure inwardly toward the longitudinal axis of the catheter body to move the ablation elements, the one or more stimulation elements, and the one or more recording elements inwardly to a contracted arrangement.

[0018] In accordance with another aspect of this invention, a method of assessing denervation comprises: introducing intravascularly a catheter to a vessel of a patient, the catheter including one or more recording elements; performing a baseline recording of responses by supplying nerve stimulation to the vessel and recording responses of the vessel to the nerve stimulation; denervating at least some tissue proximate the vessel after performing the baseline recording; performing a post-denervation recording of responses, after the denervating, by supplying nerve stimulation to the vessel and recording responses of the vessel to the nerve stimulation; and assessing denervation of the vessel based on a comparison of the responses of the baseline recording and the responses of the post-denervation recording.

[0019] In some embodiments, the catheter is not repositioned during performing the baseline recording, denervating, and performing the post-denervation recording. The nerve stimulation comprises one of electrical stimulation or pharmacological stimulation. The responses include one or more of electrical response or mechanical response. Assessing denervation of the vessel comprises: computing a baseline parameter from the responses of the baseline recording; computing a post-denervation parameter from the responses of the post-denervation recording; and computing a degree of denervation as a ratio of the post-denervation parameter and the baseline parameter. Denervation is achieved when the computed ratio falls within a preset range. The baseline parameter is computed based on a baseline maximum signal amplitude of one or more evoked responses generated in response to the nerve stimulation and recorded by the one or more recording elements before the denervating. The post-denervation is computed based on a post-denervation maximum signal amplitude of one or more evoked responses

generated in response to the same nerve stimulation and recorded by the one or more recording elements after the denervating. The one or more evoked responses include one or more of evoked electrical response or evoked mechanical response.

[0020] In specific embodiments, the baseline parameter is computed based on a baseline area under a plot of one or more evoked responses generated in response to the nerve stimulation and recorded by the one or more recording elements before the denervating. The post-denervation is computed based on a post-denervation area under a plot of one or more evoked responses generated in response to the same nerve stimulation and recorded by the one or more recording elements after the denervating. The method further comprises, if denervation of the vessel is not achieved, repeating the steps of denervating, performing a post-denervation recording of responses, and assessing denervation of the vessel until denervation of the vessel is achieved. The repeating until denervation of the vessel is achieved is performed in real time. The catheter is not repositioned during the repeating. Repeating the steps of denervating, performing a post-denervation recording of responses, and assessing denervation of the vessel comprises adjusting a level of denervation for denervating at least some tissue proximate the vessel based on result of assessing denervation of the vessel. The repeating including the adjusting until denervation of the vessel is achieved is performed in real time.

[0021] In some embodiments, recording responses of the vessel to the nerve stimulation comprises recording one or more of evoked electrical responses or mechanical responses of the vessel in response to the nerve stimulation. The vessel is denervated using one or more ablation elements disposed on the catheter. The catheter is not repositioned during performing the baseline recording, denervating, and performing the post-denervation recording. The catheter includes one or more stimulation elements to supply nerve stimulating signals as the nerve stimulation.

[0022] In specific embodiments, the method further comprises deploying a deployable structure to enhance contact between the one or more stimulation elements and the vessel and between the one or more recording elements and the vessel. The method further comprises providing electrical insulation between the one or more stimulation elements and the one or more recording elements to facilitate signal conduction between the one or more stimulation elements and tissue proximate the vessel and to facilitate signal conduction between the one or more recording elements and tissue proximate the vessel. The method further comprises deploying a deployable structure to enhance contact between the one or more recording elements and the vessel.

[0023] These and other features and advantages of the present invention will become apparent to those of ordinary skill in the art in view of the following detailed description of the specific embodiments.

BRIEF DESCRIPTION OF THE DRAWINGS

[0024] FIG. 1 is an elevational view of a catheter device with a deployable basket for assessing transvascular denervation according to an embodiment of the present invention.

[0025] FIG. 2 is an elevational view of a catheter device with a balloon-augmented deployable basket according to another embodiment of the present invention.

[0026] FIG. 3 is an elevational view of a catheter device with a deployable balloon according to another embodiment of the present invention.

[0027] FIG. 4 is a perspective view of a catheter device with a deployable sleeve according to another embodiment of the present invention.

[0028] FIGS. 5A-5F show different configurations of the stimulating and recording electrodes of the deployable sleeve of FIG. 4.

[0029] FIG. 6 is a perspective view of a partially cut-out section of the catheter device of FIG. 4.

[0030] FIG. 7 is a schematic view illustrating an apparatus to provide an intraluminal pressure sensor for use with the catheter device.

[0031] FIG. 8 is a perspective view of a catheter device with a deployable sleeve having an anti-occlusion feature according to another embodiment of the present invention.

[0032] FIGS. 8A and 8B are elevational views of a catheter device with a deployable sleeve having an anti-occlusion feature according to another embodiment of the present invention.

[0033] FIG. 9 shows an example of a flow diagram illustrating a method for assessing transvascular denervation.

[0034] FIG. 10 shows an example of a plot of evoked responses and stimulus artifacts recorded by the recording elements.

DETAILED DESCRIPTION OF THE INVENTION

[0035] In the following detailed description of the invention, reference is made to the accompanying drawings which form a part of the disclosure, and in which are shown by way of illustration, and not of limitation, exemplary embodiments by which the invention may be practiced. In the drawings, like numerals describe substantially similar components throughout the several views. Further, it should be noted that while the detailed description provides various exemplary embodiments, as described below and as illustrated in the drawings, the present invention is not limited to the embodiments described and illustrated herein, but can extend to other embodiments, as would be known or as would become known to those skilled in the art. Reference in the specification to “one embodiment”, “this embodiment”, or “these embodiments” means that a particular feature, structure, or characteristic described in connection with the embodiment is included in at least one embodiment of the invention, and the appearances of these phrases in various places in the specification are not necessarily all referring to the same embodiment. Additionally, in the following detailed description, numerous specific details are set forth in order to provide a thorough understanding of the present invention. However, it will be apparent to one of ordinary skill in the art that these specific details may not all be needed to practice the present invention. In other circumstances, well-known structures, materials, circuits, processes and interfaces have not been described in detail, and/or may be illustrated in block diagram form, so as to not unnecessarily obscure the present invention.

[0036] In the following description, relative orientation and placement terminology, such as the terms horizontal, vertical, left, right, top and bottom, is used. It will be appreciated that these terms refer to relative directions and placement in a two dimensional layout with respect to a given orientation of the layout. For a different orientation of

the layout, different relative orientation and placement terms may be used to describe the same objects or operations.

[0037] Exemplary embodiments of the invention, as will be described in greater detail below, provide apparatuses and methods for assessing transvascular denervation.

[0038] FIG. 1 is an elevational view of a catheter device with a deployable basket for assessing transvascular denervation according to an embodiment of the present invention. The device integrates neural assessment elements with denervation elements for renal denervation or the like. In the specific embodiment shown, the denervation elements are configured as ablation electrodes. In other embodiments, the ablation/denervation element may employ other mechanisms or other types of energy (e.g., laser, high intensity focused ultrasound (HIFU), cryoablation, mechanical) to sever or interrupt conduction of the nerve fibers. FIG. 1 shows ablation electrodes 11, 12, 13, 14 and additional electrodes 15, 16 which are disposed on spines 20 in a deployable structure in a basket configuration 30 which is coupled to a catheter body 40. The catheter body 40 has a proximal end 42, a distal end 44, and a longitudinal axis extending in a longitudinal direction between the distal end 44 and the proximal end 42. An external catheter handle 46 is provided at the proximal end. The spines 20 are electrically nonconductive.

[0039] In this embodiment, the deployable basket 30 is coupled to the distal portion of the catheter body 40, and is deployable or expandable outwardly from the longitudinal axis and contractible inwardly toward the longitudinal axis of the catheter body 40. The basket 30 has a plurality of longitudinal spines 20 having distal ends and proximal ends that are attached to the catheter body 40. Each spine 20 includes an elbow having at least one discontinuity in stiffness at an intermediate position between the distal end and the proximal end thereof to allow the spine to expand/deploy and collapse/contract. Different mechanisms can be used to cause the expansion and collapse of the spines 20. In FIG. 1, a pull wire 50 extending along the longitudinal axis of the catheter body 40 is used to pull the distal end of the basket 30 in the proximal direction to deploy the basket 30. The basket 30 is in a deployed configuration in FIG. 1. To return the basket 30 to a contracted/undeployed configuration with the spines 20 extending generally longitudinally in the longitudinal direction, the spines 20 can be resiliently biased toward the contracted configuration and the pulling force on the pull wire 50 can be released to allow the basket 30 to contract. Alternatively, the pull wire 50 may be configured to apply a push force to push the distal end of the basket 30 in the distal direction to contract the basket 30. In a specific embodiment, the basket 30 is contractible to a contracted arrangement to fit within a lumen of the elongated catheter body 40 and is deployable to a deployed arrangement with the elbows of the spines bending outwardly relative to the proximal and distal ends of the spines 20, the elbows of the spines moving radially outwardly from the contracted arrangement to the deployed arrangement. An example of a similar deployable basket is found in US 2010/0076426 entitled Basket Catheter Having Multiple Electrodes, which is incorporated herein by reference in its entirety.

[0040] The pull wire 50 extends through a lumen of the catheter body 40. The lumen can also accommodate lines for

supplying power to ablation electrodes, signals lines to stimulation electrodes and recording electrodes, fluid lines, and the like.

[0041] The electrodes **11**, **12**, **13**, **14**, **15**, **16** are disposed on the deployable basket **30** to move outwardly and inwardly with the basket **30**. The ablation electrodes **11**, **12**, **13**, **14** are powered to apply ablation energy to a vessel of a patient such as a renal artery. Any of the ablation electrodes can also be stimulation or recording electrodes. Stimulation electrodes are powered to supply nerve stimulating signals to the vessel. The nerve stimulating signals are typically about 1 Hz to about 16 Hz and are designed to cause nerve excitation and evoke neurotransmitter release from perivascular varicosities. The stimulation thresholds will likely be much smaller than those for neuromodulation as taught in the art, since the intent is not to irreversibly electroporate the nerves. Recording electrodes are configured to record response of the vessel to the nerve stimulating signals. In some preferred embodiments, the recording electrodes are configured to record one or more of evoked electrical responses or mechanical responses of the vessel in response to the nerve stimulating signals. The stimulation electrodes are spaced from each other, the recording electrodes are spaced from each other, and the stimulation electrodes are spaced from the recording electrodes. As seen in FIG. 1, the spacing between the electrodes can be longitudinal, lateral/circumferential, or a combination of the two. Several stimulation and recording configurations are possible in FIG. 1. A first example includes stimulation electrodes **13**, **15** and recording electrodes **14**, **16** and **11**, **12**. A second example includes stimulation electrodes **14**, **16** and recording electrodes **13**, **15**, and **11**, **12**. A third example includes stimulation electrodes **11**, **12** and recording electrodes **13**, **15** and **14**, **16**. In some preferred embodiments, at least some of the stimulation electrodes are proximal relative to at least some of the recording electrodes. The stimulation electrodes **14**, **16** are separated from the recording electrodes **11**, **12**, **13**, **15** by at least a minimum distance, which is preferably approximately equal to the space constant of excitatory junction potentials (EJPs).

[0042] Nerve stimulation is preferably applied along the long axis of the vessel or artery since the nerve cells are aligned in that direction. To detect evoked responses, however, we are interested in the VSMCs which are aligned transverse to the nerves and hence the recording bipolar electrodes will preferably be oriented in the transverse direction accordingly. More particularly, the apparatus is set up to record from different configurations and orientations of electrodes simultaneously in order to maximize the likelihood of detection.

[0043] In FIG. 1, ablation is performed with two distal electrodes (**11**, **12**) and two proximal electrodes (**13**, **14**). Neural assessment is performed with a combination of the four ablation electrodes (**11**, **12**, **13**, **14**) which also serve as stimulation or recording electrodes and two additional sensor electrodes (**15**, **16**). In neural assessment, stimulating electrodes are typically parallel to the long axis of the vessel, while recording electrodes are made up of both transverse pairs and parallel pairs to the long axis of the vessel. Stimulation and recording typically involve separate sets of electrodes, but can be configured for simultaneous stimulation and recording with appropriate electronics circuits. Stimulation and recording can be performed using bipolar electrodes as shown in FIG. 1. Alternatively, monopolar and

multipolar techniques can be used. For monopolar stimulation or recording, only one active electrode is required and an indifferent electrode is provided on the patient's tissue. Ablation is typically performed monopolarly, but bipolar or multipolar ablations are also possible with a different electrode arrangement. In some preferred embodiments, the most distal ablation electrode (**11** or **12**) is no more distal than at least one of the stimulation electrodes and the most proximal ablation electrode (**13** or **14**) is no more proximal than at least one of the recording electrodes.

[0044] FIG. 2 is an elevational view of a catheter device with a balloon-augmented deployable basket according to another embodiment of the present invention. This embodiment is similar to that of FIG. 1 with the addition of an elongated balloon **60** inside the basket **30** to replace the pull-wire expansion mechanism **50**. It inflates to expand the basket **30** outwardly in the deployed arrangement and deflates in the contracted/undeployed arrangement. This embodiment enhances tissue and electrode contact for both ablation and neural assessment. The balloon-augmented catheter is first deflated and positioned at the target renal artery site. Then the balloon **60** is inflated with saline or the like to a preset volume for neural assessment and ablation. The balloon **60** is preferably made of an electrically insulative material, which facilitates signal conduction between the stimulation electrodes and the tissue proximate the vessel and to facilitate signal conduction between the recording electrodes and the tissue proximate the vessel. The electrically insulative balloon **60** preferably permits the least resistive path for signal conduction between the stimulation electrodes and the tissue and between the recording electrodes and the tissue.

[0045] The contact force or pressure between the vessel wall and the balloon **60** is transmitted to the fluid inside the balloon **60** and measured proximally at the external catheter handle **46** via suitable instruments; alternatively, additional electromechanical contact force/pressure sensors **66** can be incorporated on the surface of the balloon **60** to record changes in the luminal wall force/pressure. FIG. 2 shows a circumferential band of contact force/pressure sensors **66**, but other sensor configurations are possible. The method of mechanical sensing here is advantageous since it is less susceptible to interference with the source of stimulus which is of a different modality (electrical). The balloon **60** may be made of a variety of materials including, for example, polyurethane or nylon.

[0046] FIG. 3 is an elevational view of a catheter device with a deployable balloon according to another embodiment of the present invention. This embodiment is similar to that of FIG. 2 but eliminates the basket and employs a balloon **70** with integrated electrodes. The electrodes may be embedded with the balloon material or printed through a thin film deposition process. For simplicity, FIG. 3 shows a similar set of electrodes **11**, **12**, **13**, **14**, **15**, **16** and force/pressure sensors **66** as those in FIGS. 1 and 2. The balloon **70** may have some or all of the same features and characteristics as the balloon **60** of FIG. 2 as described above.

[0047] FIG. 4 is a perspective view of a catheter device with a deployable sleeve according to another embodiment of the present invention. This embodiment makes use of a deployable sleeve **80** instead of a balloon to insulate the electrodes from the blood in the vessel. The sleeve **80** is preferably made of an electrically insulating material. Various arrangements of electrodes for ablation and assessing

denervation can be utilized. As an example, a spiral strip (not shown) of ablation electrode can be attached to the outside of the sleeve **80** and along the long axis of the sleeve **80**. Alternatively, the single strip may be divided into multiple ablation electrodes **82** connected in series to form a spiral arrangement along the outside of the sleeve **80**. This is the arrangement, for example, when monopolar ablation is desired and output power is divided equally across all ablation electrodes. Alternatively, ablation can be performed preferentially by bipolar means. In this case, pairs of electrodes can be grouped to create bipolar lesions that are larger and more contiguous than if monopolar lesions were created. A plurality of bipolar sets of stimulation electrodes **84** (FIGS. **4** and **5A-5F** show three pairs each being parallel to the long axis of the sleeve **80**) and a plurality of recording electrodes **86** (FIGS. **4** and **5A-5F** show three) are attached to each side of the ablation electrodes **82** respectively. The three pairs of stimulation electrodes **84** are distributed circumferentially to provide circumferential coverage of nerves. Each pair of stimulating electrodes **84** can be energized to evoke responses to be recorded with the recording electrodes **86**.

[0048] FIGS. **5A-5F** show different configurations of the stimulating and recording electrodes of the deployable sleeve **80** of FIG. **4**. The elevational view of FIG. **5A** and the end view of FIG. **5B** (from proximal end) illustrate the arrangement of the three pairs of stimulating electrodes **84** and three recording electrodes **86**. The ablation electrodes are omitted for simplicity. FIG. **5C** shows a recording configuration with the first pair of stimulation electrodes **84** active (other pairs are omitted for simplicity). The active stimulation electrodes **84** and recording electrodes **86** are connected to recording amplifiers **88**. FIG. **5D** shows a recording configuration with the second pair of stimulation electrodes **84** active (other pairs are omitted for simplicity). FIG. **5E** shows a recording configuration with the third pair of stimulation electrodes **84** active (other pairs are omitted for simplicity). FIG. **5F** shows a recording configuration with all three pairs of stimulation electrodes **84** active. A total of three contiguous stimulation-recording periods can be performed, for both baseline and post-denervation assessments. Alternatively, all three stimulating electrode pairs **86** are energized simultaneously, while evoked responses are recorded between each recording electrode **86** and an indifferent electrode or electronic ground.

[0049] Lead wires for all the electrodes as well as thermocouple wires are embedded within the sleeve substrate. During ablation the ablation electrode circuit is closed, while the neural assessment electrode circuit is open. Following ablation, the opposite is true for neural assessment, i.e., the ablation electrode circuit is open, and the neural assessment electrode circuit is closed. Additional electromechanical sensors for force/pressure sensing and the like can likewise be incorporated as the sensors **66** on the balloons **60**, **70** of FIGS. **2** and **3**. The sleeve **80** may be made of a variety of materials including, for example, polyurethane or nylon.

[0050] FIG. **6** is a perspective view of a partially cut-out section of the catheter device of FIG. **4**. The sleeve **80** is moved between a deployed arrangement and a contracted/undeployed arrangement using any suitable mechanism. The sleeve **80** is open and non-occlusive, except for the mechanism of deploying and contracting. In the example seen in FIG. **6**, the sleeve **80** is contracted using three sets of draw

strings **90** located near the distal and proximal ends as well as midpoint of the sleeve **80**. The draw strings **90** are drawn into a hollow tubing **92**, which is capped at the distal end, through the holes **94** per draw string **90**. All three draw strings **90** are joined together at a proximal distance by a pull wire **96** that is controlled at the proximal catheter handle **46**. To release the draw strings **90**, the handle **46** will first advance the pull wire **96** to relax the draw strings **90**, and then a bolus of saline or the like is injected through the tubing **92** creating an outward pressure at the draw string holes **94** (and optionally additional holes) and forces the sleeve **80** to expand towards the vascular wall, thus insulating the electrodes from the vessel. To move the sleeve **80** to the contracted arrangement, the pull wire **96** is retracted at the handle **46** to pull the draw strings **90** to draw the sleeve **80** radially inwardly. The non-occlusive sleeve **80** is deployed by exerting a positive differential pressure by the injected fluid against the blood in the vessel, and once deployed, is kept in place (i.e., in contact with vessel wall) by the blood pressure. In the reverse action of contracting, the draw strings **90** are retracted into the hollow tubing **92** by the pull wire **96**, having overcome the positive blood pressure exerted against the sleeve **80**.

[0051] FIG. **7** is a schematic view illustrating an apparatus to provide an intraluminal pressure sensor for use with the catheter device. In the embodiment shown, the intraluminal pressure sensor **100** is introduced proximally and deployed inside the balloon **102** (which may be balloon **60** of FIG. **2** or balloon **70** of FIG. **3**) for pressure monitoring while maintaining the balloon **102** isovolumic. The apparatus of FIG. **7** includes an analyzer **106** coupled to the pressure sensor **100**, a syringe **110** and a fluid port **112** for introducing a fluid into the balloon **102**, and an electrical port **116** for supplying electrical energy to the catheter device. This provides an alternative or an additional mechanism for pressure sensing while maintaining the balloon **102** isovolumic.

[0052] FIG. **8** is a perspective view of a catheter device with a deployable sleeve having an anti-occlusion feature according to another embodiment of the present invention. This embodiment is similar to that of FIGS. **4** and **5** but the sleeve structure is modified to provide an anti-occlusion feature to permit blood/fluid flow in the vessel between the proximal end and the distal end of the deployable sleeve structure in the deployed arrangement. In FIG. **8**, the sleeve **120** remains flexible and has electrodes similar to those in FIG. **4**. A plurality of rib channels **122** are used to connect the lumen of the hollow tubing **92** to an enclosed interior of sleeve **120** between its outer shell **124** and inner shell **126**. The interior of the sleeve **120** and the rib channels **122** are capped or closed at the proximal and distal ends. The inner shell **126** of the sleeve **120** is preferably noncompliant so that it does not stretch or expand beyond its preset expanded shape. The outer shell **124** of the sleeve **120** is preferably semi-compliant so that it can stretch under the pressure of the fluid supplied to the interior of the sleeve **120** to enhance contact between the electrodes and the vessel wall. The rib channels **122** span the length of the sleeve **120** and are preferably flexible but noncompliant. Open flow paths are provided between the rib channels **122** to permit fluid flow in the vessel between the proximal end and the distal end of the sleeve **120** in the deployed arrangement.

[0053] FIGS. **8A** and **8B** are elevational views of a catheter device with a deployable sleeve having an anti-occlu-

sion feature according to another embodiment of the present invention. The sleeve 202 is undeployed in FIG. 8A and deployed in FIG. 8B. The sleeve 202 is connected or bonded to a set of distal spines 206 and a set of proximal spines 208. The distal spines 206 are connected between a distal termination end 210 and a distal retainer 212. The proximal spines 208 are connected between a proximal retainer 214 and a proximal termination end 216. The distal termination end 210 and proximal termination end 216 are both fixed to the catheter body 218, and are hence separated by a fixed distance. A resilient member such as a spring 220 is connected between the distal retainer 212 and the proximal retainer 214. A wire 222, which is a pull wire or a push-pull wire, is fixed at one end to a wire anchor 226 on the proximal retainer 214 and loops through holes in the proximal retainer 214 and the distal retainer 212 to the proximal portion of the catheter body 218. In FIG. 8A, the wire 222 is pulled to produce a pre-compressed spring 220. The distal spines 206 and proximal spines 208 as well as the sleeve 202 are in the collapsed/contracted/undeployed state. FIG. 8B shows the distal spines 206, proximal spines 208, and sleeve 202 in the expanded/deployed state. By releasing the tension on the wire 222, the spring 220 stretches, thereby pushing the distal retainer 212 and proximal retainer 214 apart. The distal retainer 212 moves toward the distal termination end 210 and the proximal retainer 214 moves toward the proximal termination end 216. This causes the distal spines 206 and the proximal spines 208 to expand laterally and deploy the sleeve 202 radially outwardly. The ends of the sleeve 202 are open in the deployed state of FIG. 8B, thereby allowing fluid flow in the vessel between the proximal end and the distal end of the sleeve 202 in the deployed arrangement without occlusion.

[0054] Other configurations of deployable structures and features can be used. For example, a deployable structure may be formed by a plurality of longitudinal strips that can be pulled in the longitudinal direction toward a straight configuration in the contracted/undeployed arrangement. When the pulling force is removed, the longitudinal strips expand radially outwardly into a spiral configuration in the deployed arrangement, for instance, under a resilient biasing force such as a memory shape material. Another example of a deployable structure is an S-shaped structure having one or more stimulating elements at the distal end thereof, one or more ablation elements on the first/distal hump of the S-shaped structure from the distal end thereof, and one or more recording elements on the second/proximal hump of the S-shaped structure from the distal end thereof. The S-shaped structure is preformed into the S-shape (e.g., using a shape memory material). It is stretched/deformed toward a straight configuration (e.g., using a stylet) in the contracted arrangement and is allowed to return to the S-shape in the deployed arrangement.

[0055] FIG. 9 shows an example of a flow diagram illustrating a method for assessing transvascular denervation. To assess transvascular denervation using the apparatus described above, a user introduces intravascularly any of the above catheter devices to a target vessel of a patient and deploys it (step 902), and performs a baseline recording of responses by supplying nerve stimulating signals to the vessel with the stimulation electrodes and records responses of the vessel to the nerve stimulating signals using the recording electrodes (step 904). Next, the ablation electrodes are activated to ablate/denervate at least some tissue proximate

the vessel (step 906). The user then performs a post-ablation recording of responses, after the denervating, by supplying nerve stimulating signals to the vessel with the stimulation electrodes and records responses of the vessel to the nerve stimulating signals using the recording electrodes (step 908). The user can assess denervation of the vessel based on a comparison of the responses of the baseline recording and the responses of the post-ablation recording (step 910). For stimulation and recording, it is preferable to deploy or expand a deployable structure (e.g., basket, balloon, sleeve, or the like) to enhance contact between the stimulation electrodes and the vessel wall and between the recording electrodes and the vessel wall. Ablation/denervation elements are preferably provided on the catheter device. As such, it is not necessary to reposition the catheter during the baseline recording, the ablation, and the post-ablation recording.

[0056] The responses include, for example, electrical response and/or mechanical response, which can be evoked excitatory junctional potentials or wall tension of the vessel in response to the nerve stimulating signals. In general, assessing denervation of the vessel includes computing a baseline parameter from the responses of the baseline recording, computing a post-ablation parameter from the responses of the post-ablation recording, and computing a degree of denervation as a ratio of the post-ablation parameter and the baseline parameter. The desired denervation is achieved when the computed ratio falls within a preset range. In one example, the baseline parameter is computed based on a baseline maximum signal amplitude of one or more evoked responses generated in response to stimulation of nerve stimulating signals by the stimulation elements and recorded by the recording elements before the ablating, and the post-ablation is computed based on a post-ablation maximum signal amplitude of one or more evoked responses generated in response to the same stimulation of nerve stimulating signals by the stimulation elements and recorded by the recording elements after the ablating. The evoked responses may include evoked electrical response and/or evoked mechanical response such as can be detected with a pressure sensor. In another example, the baseline parameter is computed based on a baseline area under a plot of one or more evoked responses generated in response to stimulation by the stimulation elements and recorded by the recording elements before the ablating, and the post-ablation is computed based on a post-ablation area under a plot of one or more evoked responses generated in response to the same stimulation by the stimulation elements and recorded by the recording elements after the ablating. FIG. 10 shows an example of a plot of evoked responses and stimulus artifacts recorded by the recording elements. The evoked responses each have an amplitude and an area. For multiple evoked responses, an average of the amplitudes or an average of the areas may be used to calculate the parameter.

[0057] If denervation of the vessel is not achieved, the user can repeat the steps of denervating (step 906), performing a post-ablation recording of responses (step 908), and assessing denervation of the vessel (step 910) until denervation of the vessel is achieved. The catheter need not be repositioned during the repeating. In some cases, repeating those steps include adjusting an energy level of ablation or a number of ablation elements for ablating tissue proximate the vessel based on the result of assessing denervation of the vessel. The repeating with or without the adjusting until denervation

of the vessel is achieved is preferably performed in real time. The recording and assessing are preferably done in real time so that the assessment results can be provided as feedback to the user who can repeat the steps in real time, including adjusting the denervation in real time if necessary, to achieve the desired denervation for the patient undergoing the medical procedure in real time. If it is desired to adjust the position of the ablation or denervation elements the step of performing a baseline evoked response measurement should be repeated after the elements are repositioned and before the subsequent denervation step.

[0058] As an example, the baseline recording of evoked responses is performed to compute a parameter A_i which can be derived from a number of variables such as the maximum signal amplitude or area under the first volley as mentioned above. The post-ablation assessment yields a second parameter A_o . The degree of denervation is computed as the DNA_i given by A_o/A_i . The neural assessment method can be extended to provide closed loop control of denervation by interleaving ablation with neural assessment, for example, by incrementing the number of electrodes involved in ablation after each neural assessment until the DNA_i is reduced below a certain threshold or falls within a preset range. This approach minimizes the need to move the catheter to different segments of the vessel for total coverage of denervation. Neural assessments can be done with bipolar or unipolar stimulation, but preferably bipolar. The bipolar stimulus can be either constant current or constant voltage, and is preferably a square wave with a pulse duration of about 0.1-1 millisecond, more preferably about 0.2-0.5 millisecond, and an amplitude of about 1-20 mA or 1-20 V, more preferably about 5-10 mA or 5-10 V. The stimulus is repeated typically at a rate of about 0.5-20 Hz for a total of about 5-30 seconds.

[0059] An alternative to electrical stimulation is pharmacological stimulation. Examples include the use of alpha-latrotoxin or ciguatoxin, which can be applied extraluminally (e.g., at 1 nM dose) to the renal artery. The drug can be delivered using a micro-infusion needle that penetrates the arterial wall to reach the perivascular axons. For instance, a balloon can be used to drive the needle into the arterial wall. The drug can temporarily activate or accelerate the release of neurotransmitters from perivascular varicosities and thus generate the evoked response for signal recording. The micro-infusion needle will replace the stimulation electrodes of the above embodiments while the recording electrodes are still used to record the response to the nerve stimulation produced by the drug.

[0060] The above-described method provides a direct and immediate assessment of the transvascular denervation procedure. It ensures optimal titration of energy to achieve denervation end point and provides a way to predict clinical outcome of denervation, preferably in real time. In the description, numerous details are set forth for purposes of explanation in order to provide a thorough understanding of the present invention. However, it will be apparent to one skilled in the art that not all of these specific details are required in order to practice the present invention. It is also noted that the invention may be described as a process, which is usually depicted as a flowchart, a flow diagram, a structure diagram, or a block diagram. Although a flowchart may describe the operations as a sequential process, many of the operations can be performed in parallel or concurrently. In addition, the order of the operations may be re-arranged.

[0061] From the foregoing, it will be apparent that the invention provides methods, apparatuses and programs stored on computer readable media for ablation using an irrigated catheter device with multiple segmented ablation segments. Additionally, while specific embodiments have been illustrated and described in this specification, those of ordinary skill in the art appreciate that any arrangement that is calculated to achieve the same purpose may be substituted for the specific embodiments disclosed. This disclosure is intended to cover any and all adaptations or variations of the present invention, and it is to be understood that the terms used in the following claims should not be construed to limit the invention to the specific embodiments disclosed in the specification. Rather, the scope of the invention is to be determined entirely by the following claims, which are to be construed in accordance with the established doctrines of claim interpretation, along with the full range of equivalents to which such claims are entitled.

1.-36. (canceled)

37. A method of evaluating the intraprocedural success of a renal denervation procedure on a subject, the method comprising:

supplying nerve-stimulating signals to multiple evenly distributed points about a circumference of a renal artery of the subject to determine a baseline physiological response of the subject;

performing a renal denervation procedure on the renal artery of the subject;

supplying nerve-stimulating signals to the multiple points about the circumference of the renal artery of the subject to determine the physiological response of the subject;

assess denervation of the renal artery by comparing the baseline physiological response of the subject prior to renal denervation with the physiological response after renal denervation.

38. The method of claim **37** further comprising determining whether to perform additional renal denervation on the subject by using the compared physiological responses.

39. The method of claim **37** wherein the electrical stimulation of the renal artery and the renal denervation are performed using the same ablation catheter.

40. The method of claim **39** wherein the ablation catheter comprises at least four ablation electrodes and at least four electrical stimulation electrodes.

41. The method of claim **39** wherein the ablation catheter is a balloon catheter.

42. The method of claim **39** wherein the ablation catheter comprises at least four ablation electrodes.

43. The method of claim **40** wherein ablation catheter includes at least four splines and the ablation electrodes and the electrical stimulation electrodes are positioned and configured on the at least four splines.

44. The method of claim **40** wherein the nerve-stimulation signals are supplied using sequential electrical stimulation.

45. The method of claim **5** wherein the nerve-stimulation signals are supplied using simultaneous electrical stimulation.

46. The method of claim **37** wherein the nerve-stimulation signals are supplied using monopolar electrical stimulation.

47. The method of claim **37** wherein the nerve-stimulation signals are supplied using bipolar electrical stimulation.

48. The method of claim **37** wherein the physiological response of the subject measured is blood pressure.

49. The method of claim **37** wherein the nerve-stimulation signals are supplied using rectangular pulse waves.

50. The method of claim **37** wherein the nerve-stimulation signals provide current in an amount of from about 1 milliamps to about 20 milliamps at a frequency of from about 0.5 Hertz to about 20 Hertz for a time period of from about 0.1 millisecond to about 1 milliseconds.

51. The method of claim **50** wherein the electrical stimulation provides current in an amount of from about 5 milliamps to about 10 milliamps at a frequency of from about 0.5 Hertz to about 20 Hertz for a time period of from about 0.2 millisecond to about 0.5 milliseconds.

52. A method of determining the end point of a renal denervation procedure on a subject, the method comprising:
supplying nerve-stimulating signals to at least three circumferentially evenly spaced locations about a renal artery of the subject through electrical stimulation to determine a baseline reading of the subject's blood pressure using an ablation catheter comprising at least three ablation electrodes and at least three electrical stimulation electrodes and configured to electrically contact the at least three circumferentially spaced locations about the renal artery;

performing a renal denervation procedure on the renal artery of the subject using the ablation catheter;

supplying nerve-stimulating signals to the at least three circumferentially spaced locations about the renal artery of the subject through electrical stimulation using the ablation catheter configured to electrically contact the at least three circumferentially spaced locations about the renal artery and determine the subject's blood pressure;

comparing the baseline blood pressure of the subject prior to renal denervation with the blood pressure after renal denervation; and

determining whether to perform an additional renal denervation procedure.

53. The method of claim **52** wherein the nerve-stimulation signals provide current in an amount of from about 1 milliamps to about 20 milliamps at a frequency of from about 0.5 Hertz to about 20 Hertz for a time period of from about 0.1 millisecond to about 1 milliseconds.

54. The method of claim **52** wherein the nerve-stimulation signals are supplied using bipolar electrical stimulation.

* * * * *

| | | | |
|---------------|---|-----------------------|------------|
| 专利名称(译) | 评估经血管去神经支配的装置和方法 | | |
| 公开(公告)号 | US20180333204A1 | 公开(公告)日 | 2018-11-22 |
| 申请号 | US16/018577 | 申请日 | 2018-06-26 |
| 申请(专利权)人(译) | ST.犹达医疗用品, INC. | | |
| 当前申请(专利权)人(译) | ST.犹达医疗用品, INC. | | |
| [标]发明人 | NG KOK HWEE | | |
| 发明人 | NG, KOK-HWEE | | |
| IPC分类号 | A61B18/14 A61B5/0215 A61B5/00 A61B5/04 A61B18/00 A61B90/00 | | |
| CPC分类号 | A61B18/1492 A61B5/0215 A61B5/04001 A61B5/6853 A61B5/6885 A61B2018/0016 A61B2018/0022 A61B2018/00226 A61B2018/00267 A61B2018/00345 A61B2018/00404 A61B2018/00434 A61B2018/00511 A61B2018/00577 A61B2018/00642 A61B2018/00672 A61B2018/00678 A61B2018/00702 A61B2018/00839 A61B2018/1475 A61B2090/064 | | |
| 外部链接 | Espacenet | USPTO | |

摘要(译)

用于评估去神经支配的导管设备包括：细长的导管主体；连接到导管主体的可展开结构，可展开结构可从导管主体的纵向轴线向外展开并向内收缩；设置在可展开结构上的一个或多个消融元件与可展开结构一起向外和向内移动；一个或多个刺激元件彼此间隔开并设置在可展开结构上以与可展开结构一起移动，刺激元件被供电以向血管提供神经刺激信号；一个或多个记录元件彼此间隔开并与刺激元件隔开，记录元件设置在可展开结构上以与可展开结构一起移动，记录元件配置成记录血管对神经刺激信号的响应。

