



US 20170007177A1

(19) **United States**

(12) **Patent Application Publication**
VALDASTRİ et al.

(10) **Pub. No.: US 2017/0007177 A1**
(43) **Pub. Date: Jan. 12, 2017**

(54) **A DEVICE FOR MEASURING A PLURALITY OF PARAMETERS IN PATIENT SUBJECT TO A TREATMENT WITH RADIOPHARMACEUTICALS**

A61N 5/10 (2006.01)
A61B 5/0205 (2006.01)
(52) **U.S. Cl.**
CPC *A61B 5/4848* (2013.01); *A61B 5/002* (2013.01); *A61B 5/6823* (2013.01); *A61B 5/6824* (2013.01); *A61N 5/1071* (2013.01); *A61N 5/1075* (2013.01); *A61B 5/02055* (2013.01); *A61B 5/7203* (2013.01); *A61B 6/42* (2013.01); *A61B 6/463* (2013.01); *G06F 19/3481* (2013.01); *G06F 19/3406* (2013.01); *G06F 19/3437* (2013.01); *A61N 2005/1021* (2013.01); *A61B 2560/0456* (2013.01); *A61B 2562/06* (2013.01); *A61B 2562/18* (2013.01); *A61B 5/021* (2013.01)

(71) Applicant: **WINMEDICAL S.R.L.**, Pisa (IT)

(72) Inventors: **Pietro VALDASTRİ**, Livorno (IT);
Ferdinando DE NEGRI, Pisa (IT)

(73) Assignee: **WINMEDICAL S.R.L.**, Pisa (IT)

(21) Appl. No.: **15/116,330**

(22) PCT Filed: **Feb. 16, 2015**

(86) PCT No.: **PCT/IB2015/051128**

§ 371 (c)(1),

(2) Date: **Aug. 3, 2016**

(30) **Foreign Application Priority Data**

Feb. 17, 2014 (IT) PI2014A000013

Publication Classification

(51) **Int. Cl.**

A61B 5/00 (2006.01)
G06F 19/00 (2006.01)
A61B 6/00 (2006.01)

(57) **ABSTRACT**

A device for measuring a plurality of parameters of a patient subject to a treatment with radiopharmaceuticals includes a main body constrained to the patient's body in such a way that the measurement device is of wearable type. The device includes a plurality of measurement modules, for example a first module and a second module, each of which is equipped with a respective sensor, configured to measure a predetermined parameter of the patient. The device is also equipped with a microprocessor configured to process a plurality of data measured by the plurality of sensors, obtaining a plurality of processed data. Furthermore, a transmission means is provided of wireless type arranged to send via wireless communication the data processed by the microprocessor to a remote control unit.

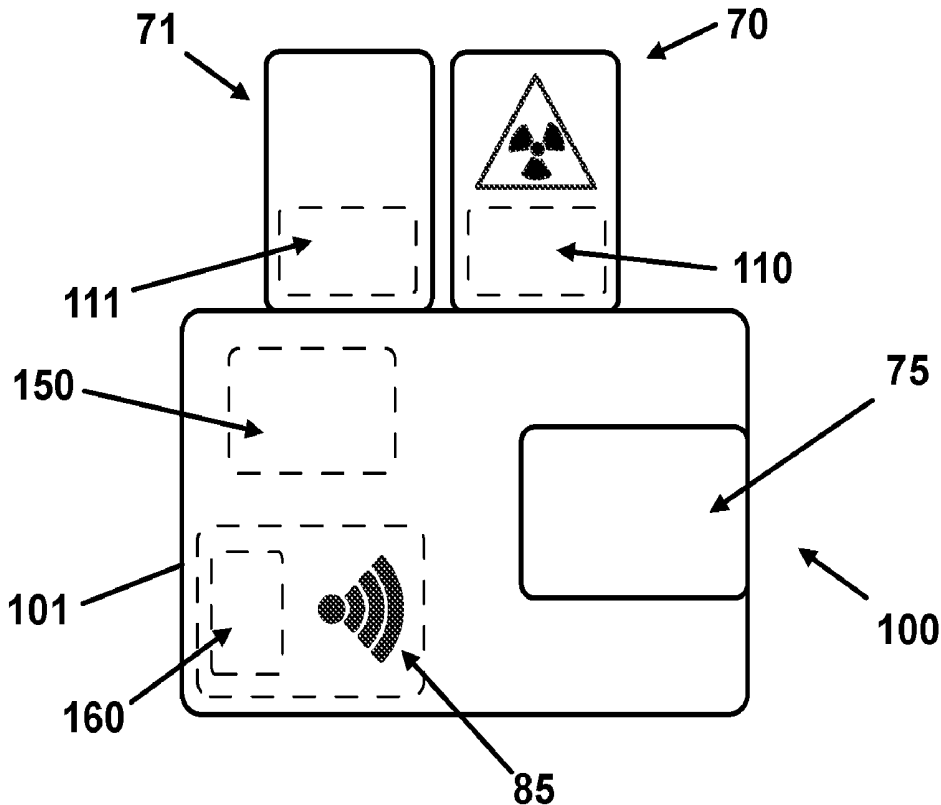

Fig. 1A

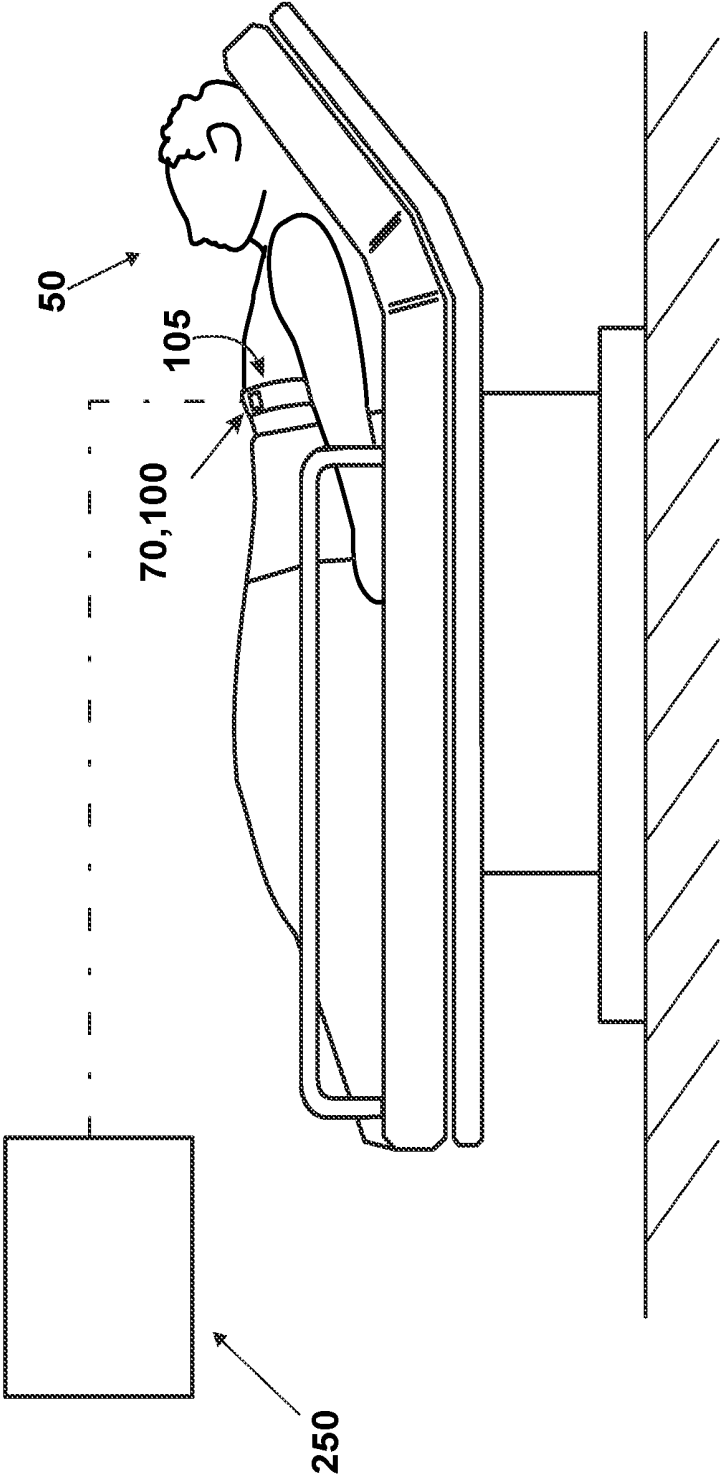

Fig. 1B

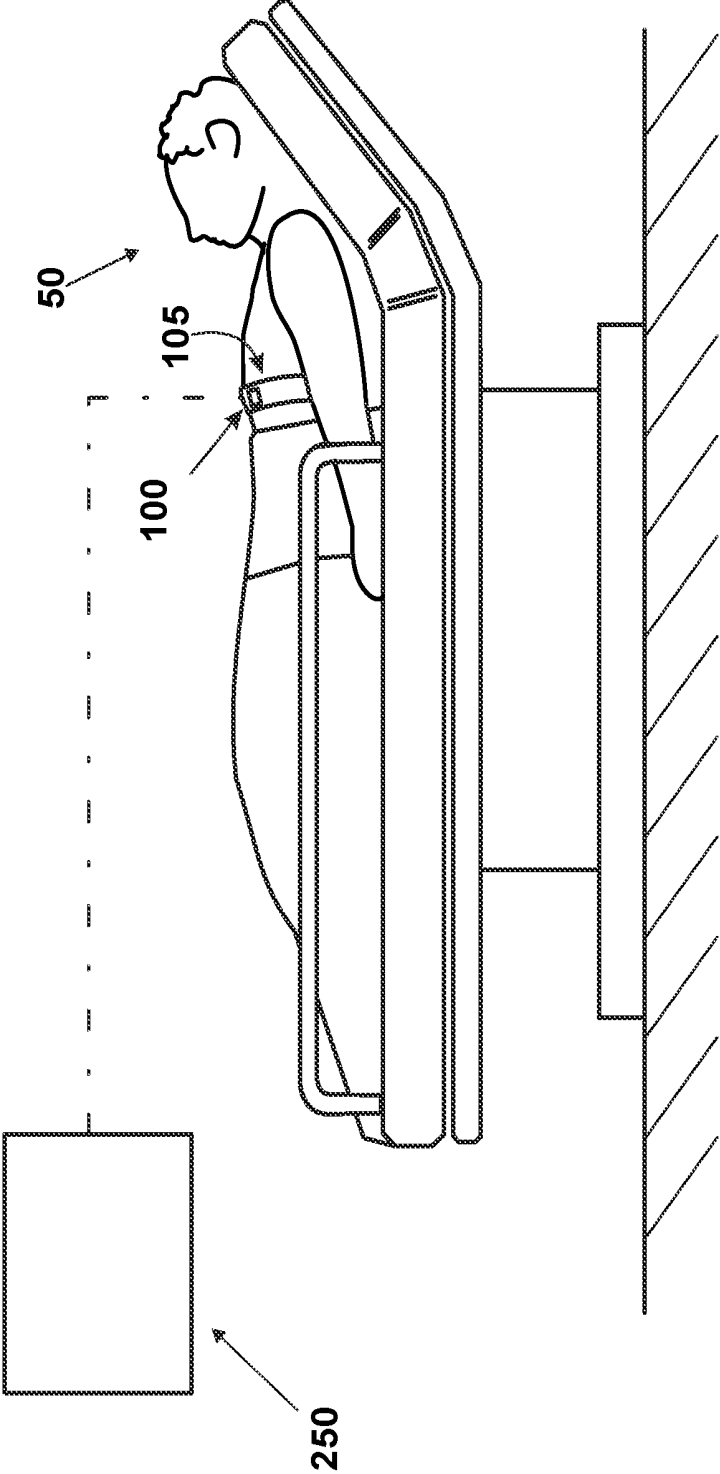

Fig. 2A

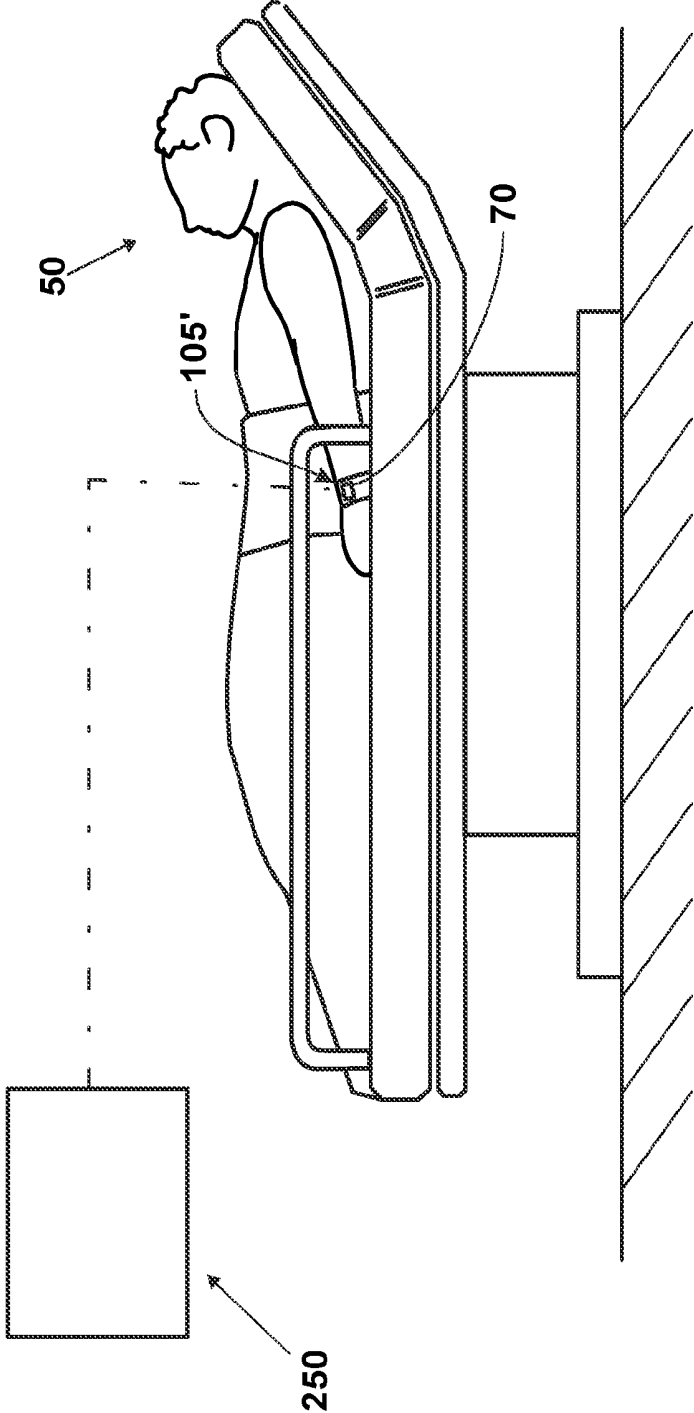
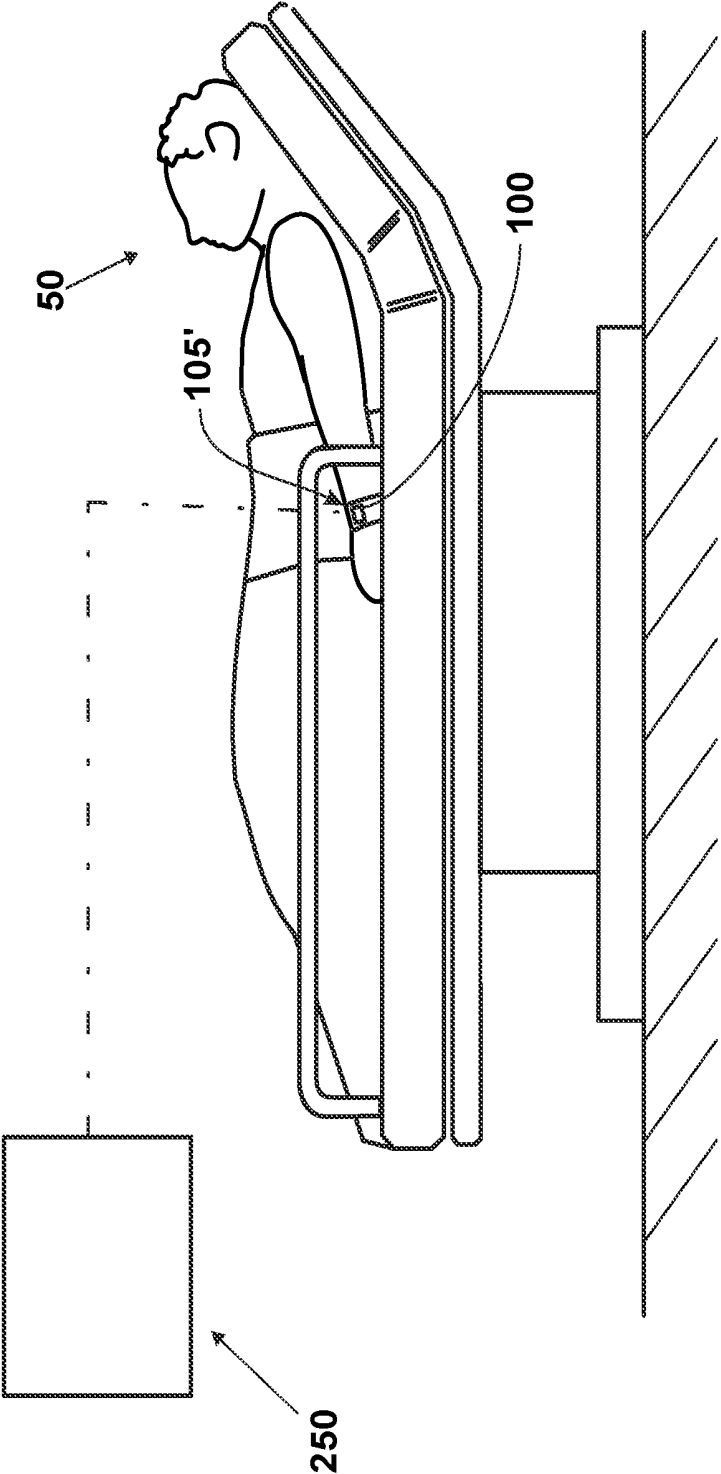

Fig. 2B



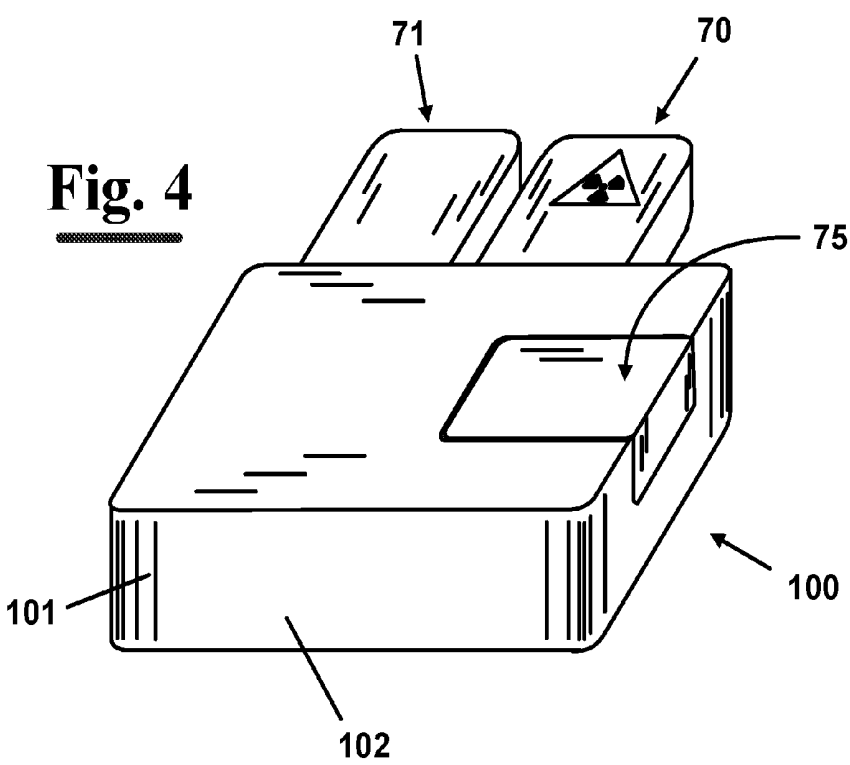
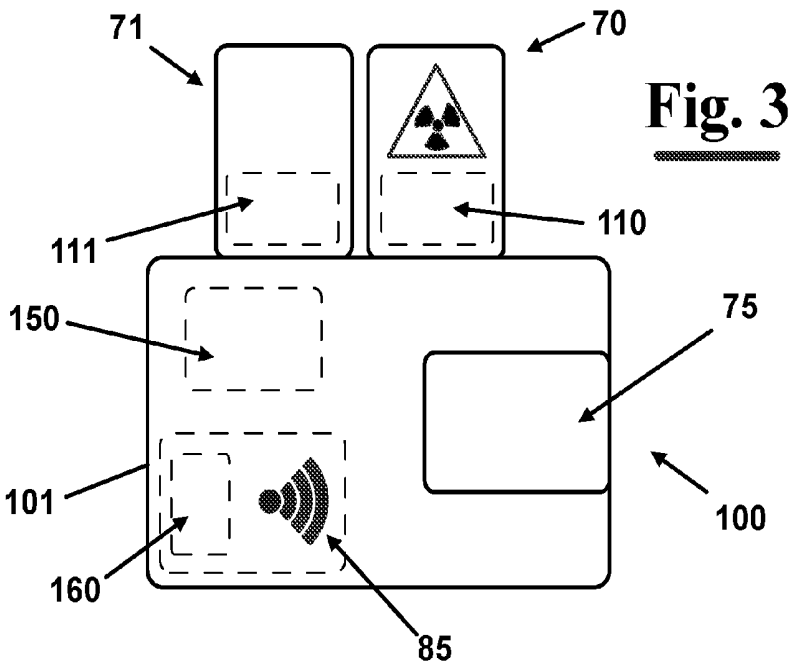

Fig. 5

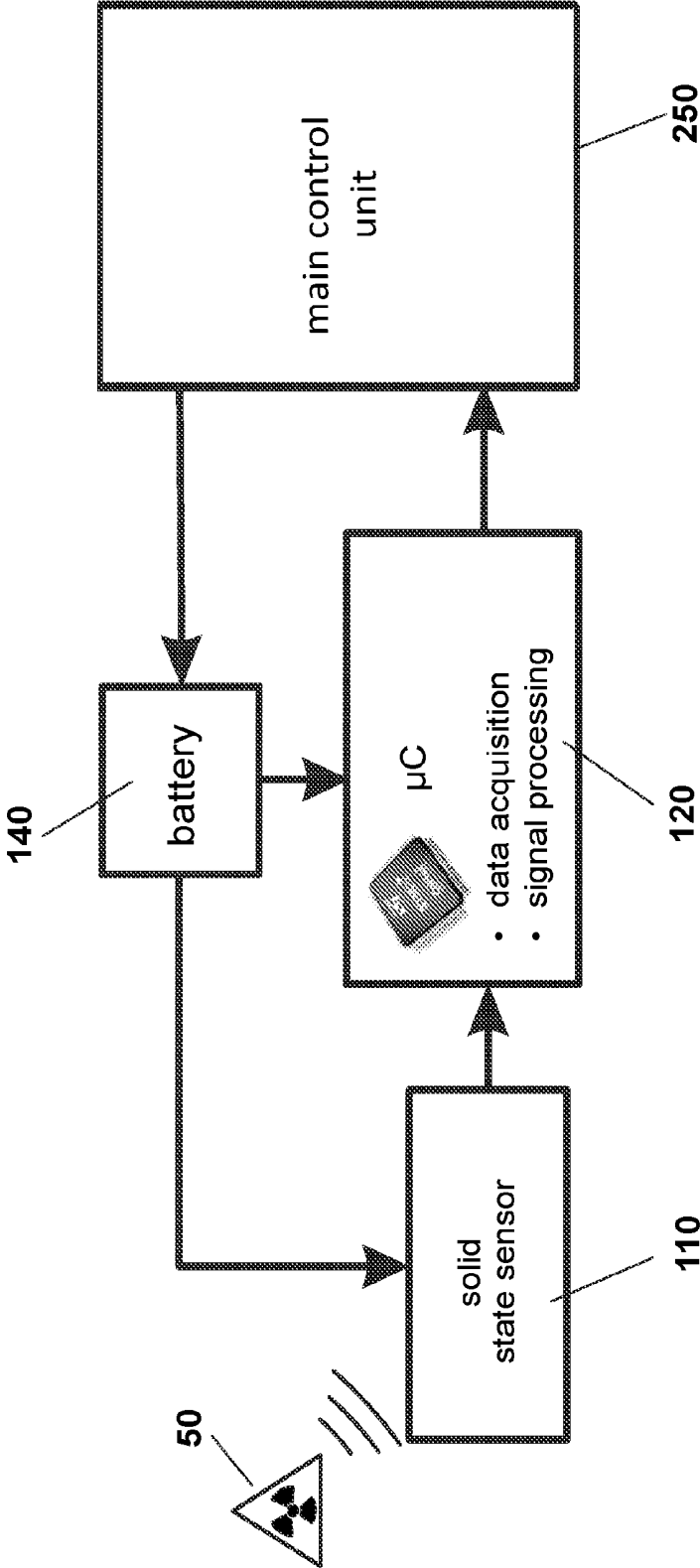
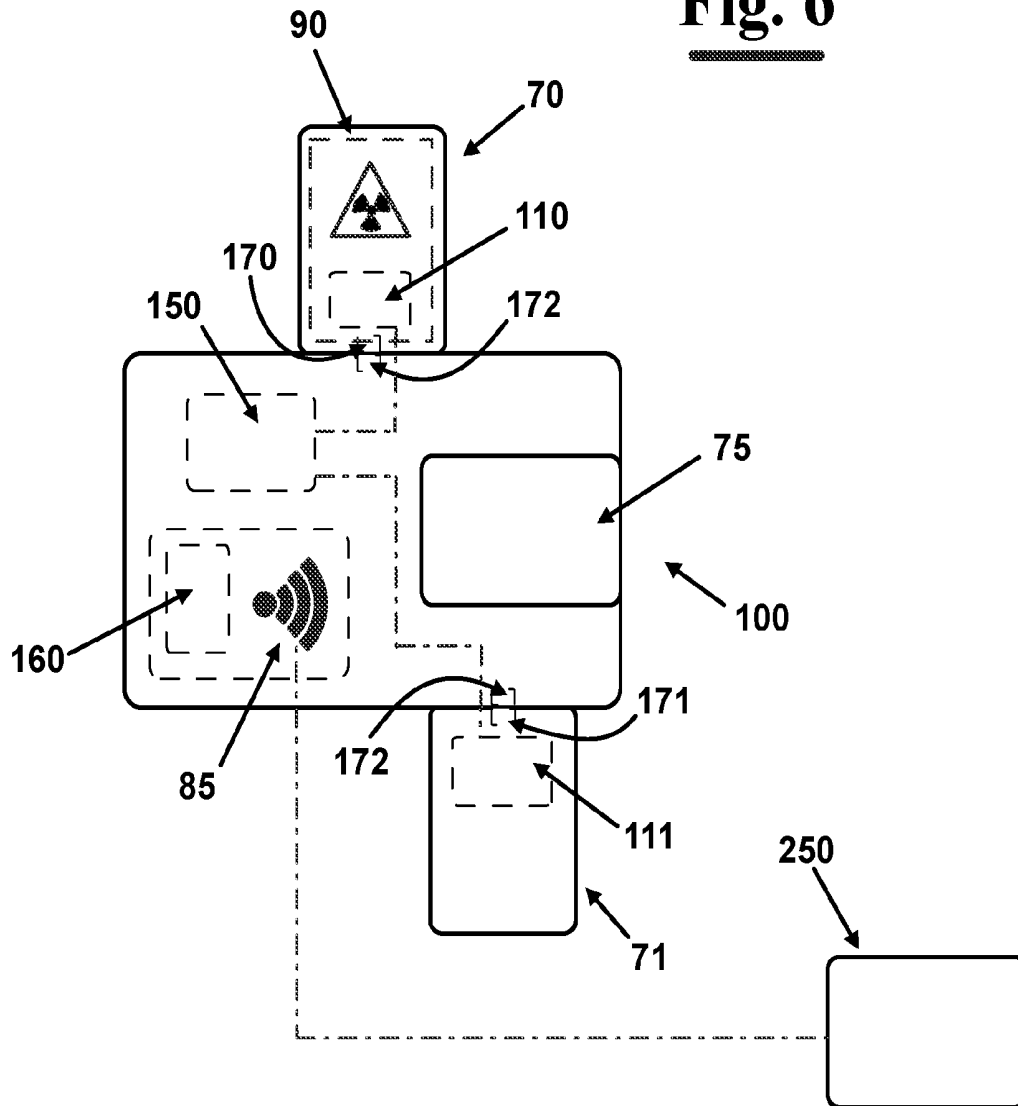

Fig. 6



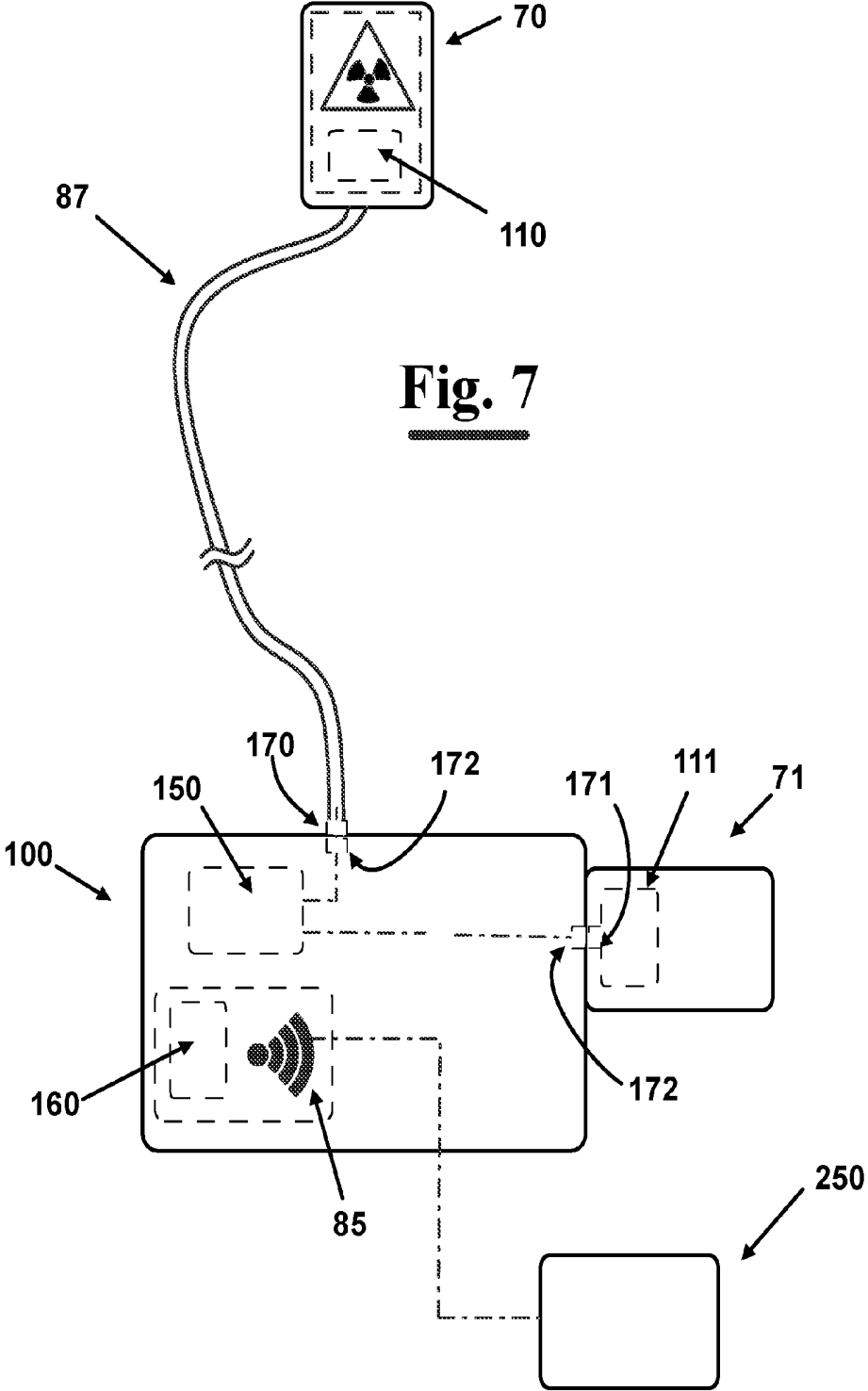
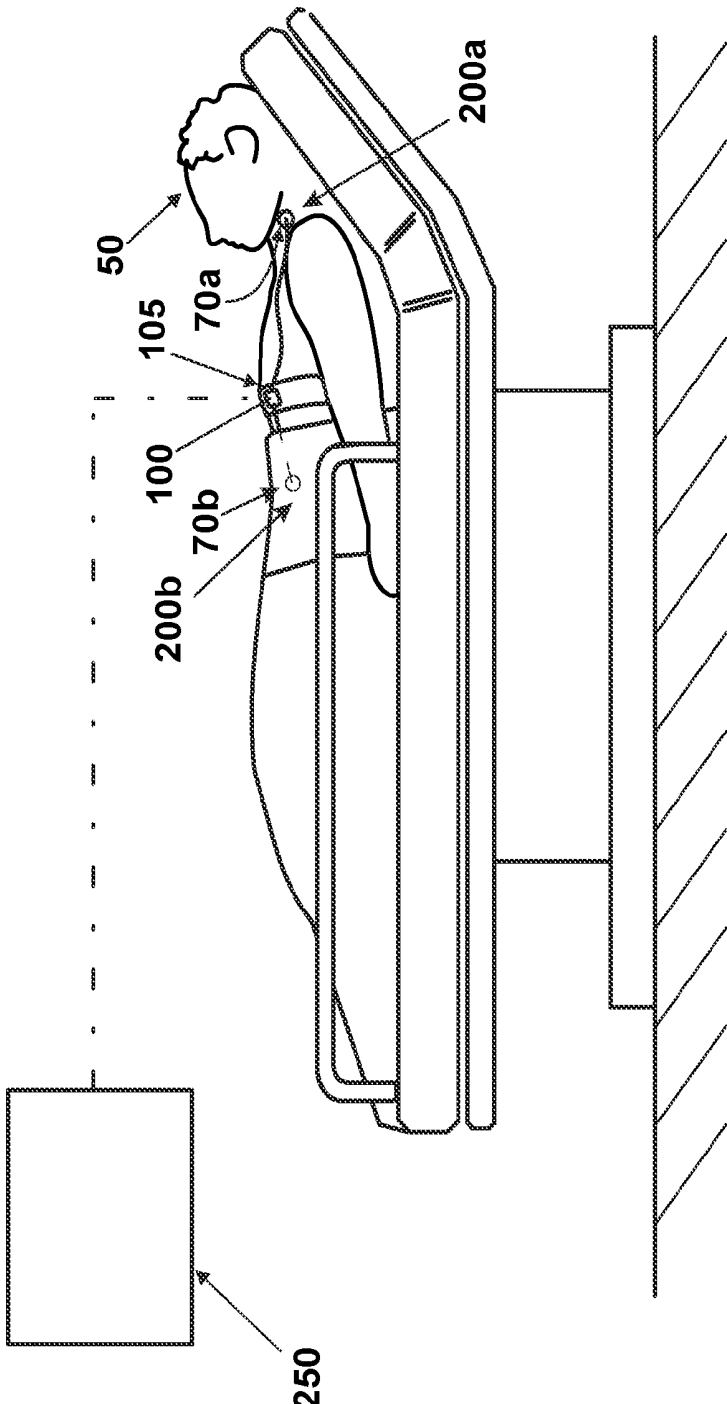

Fig. 8



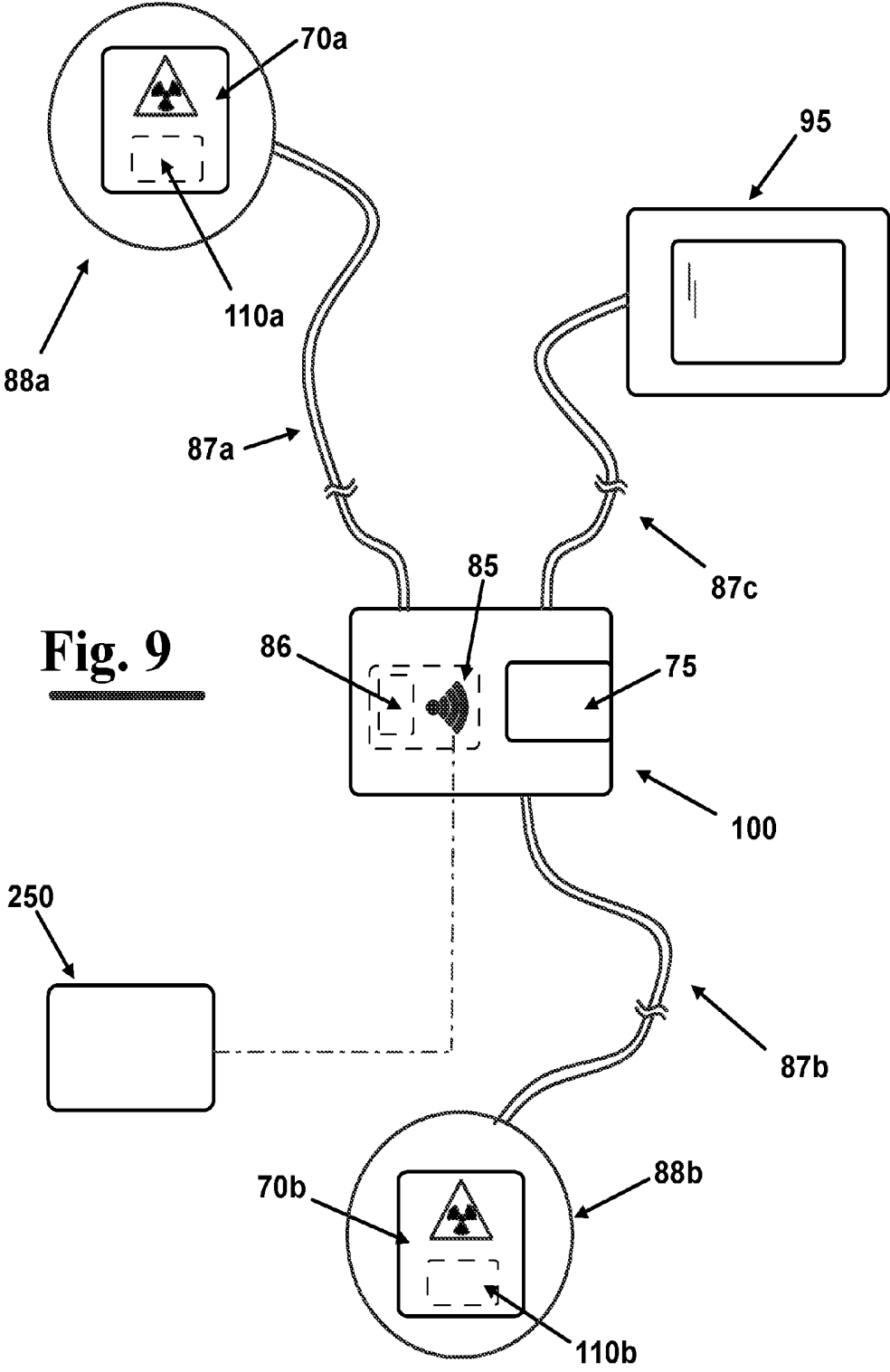

Fig. 9

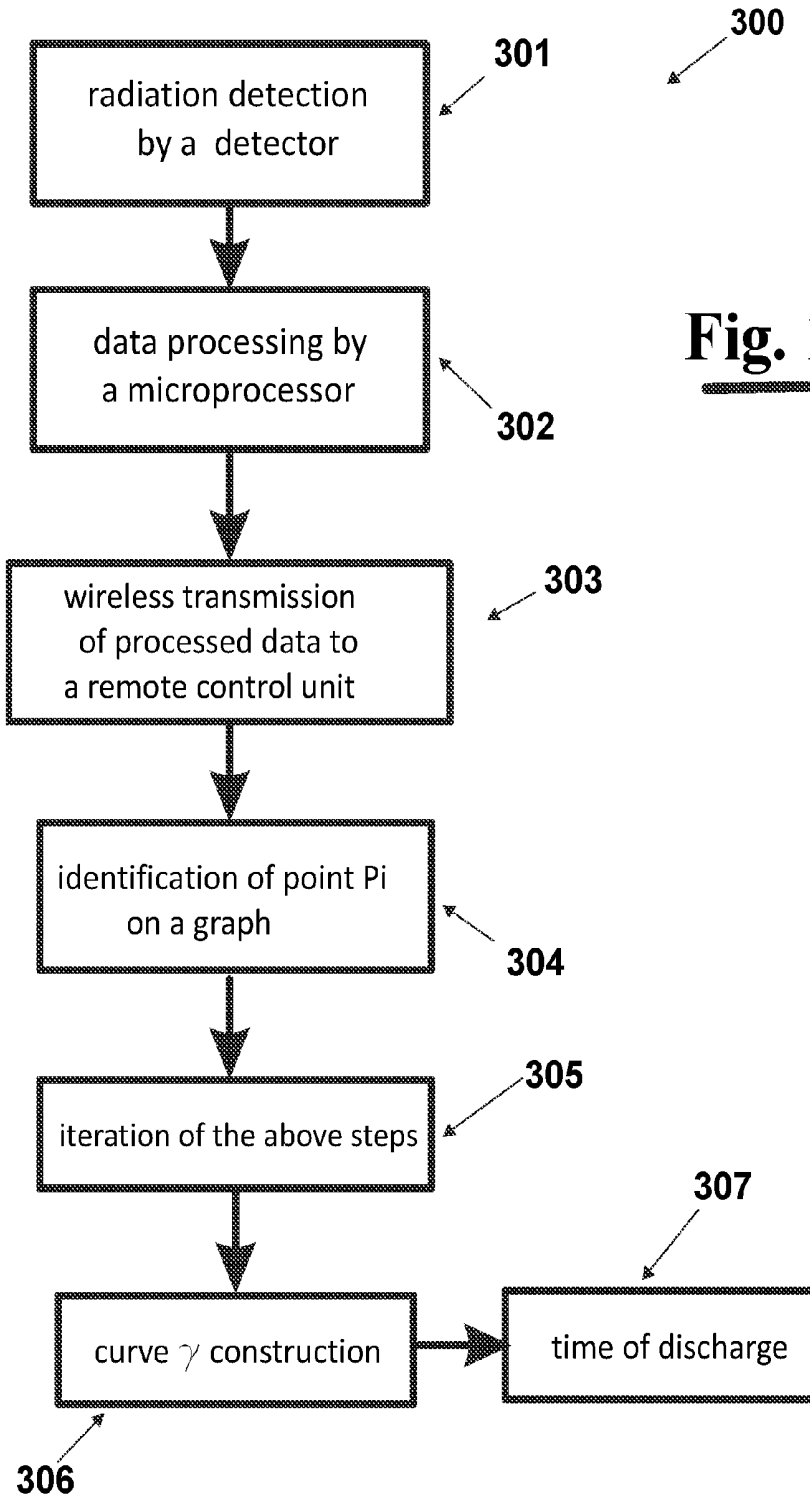
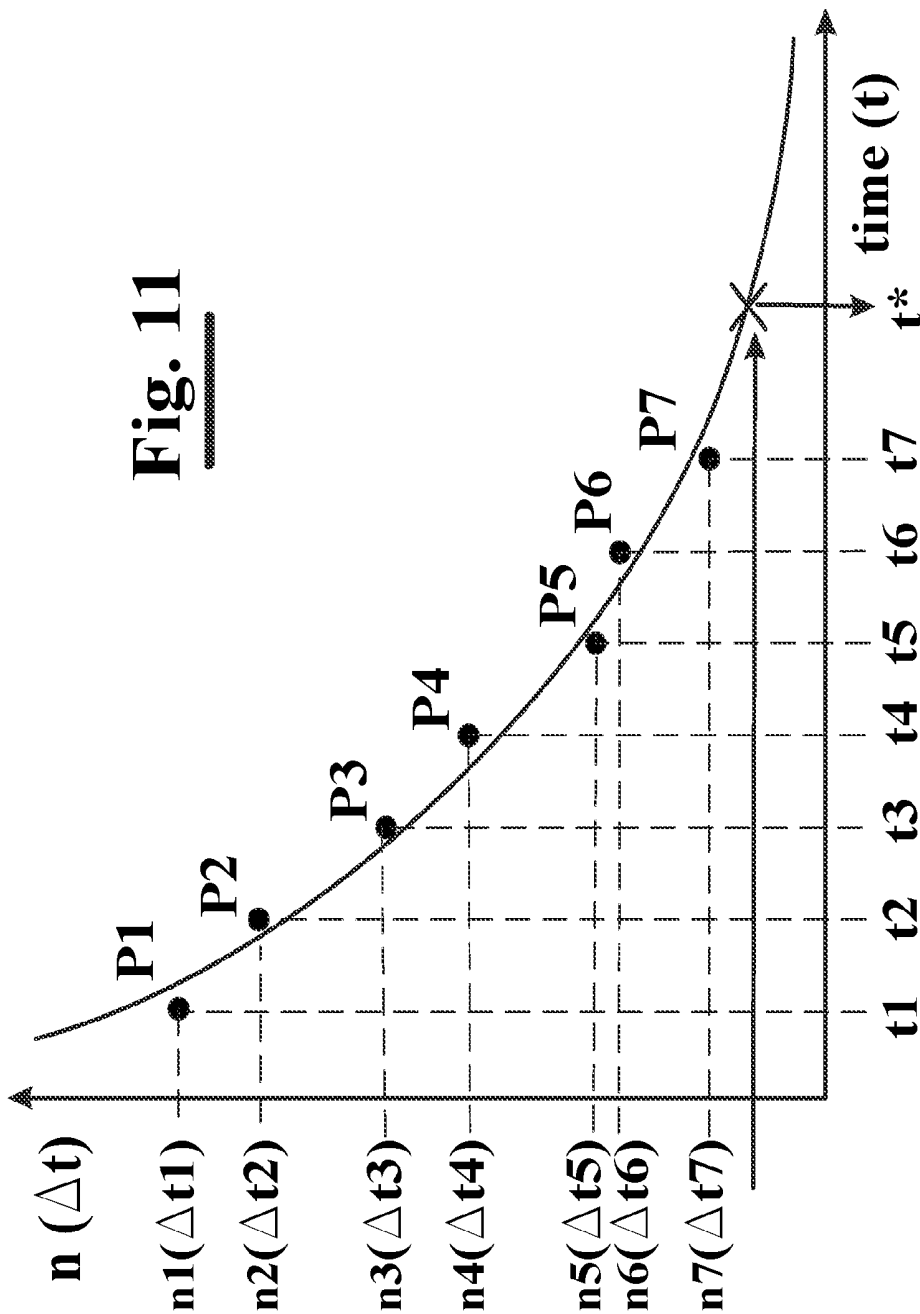
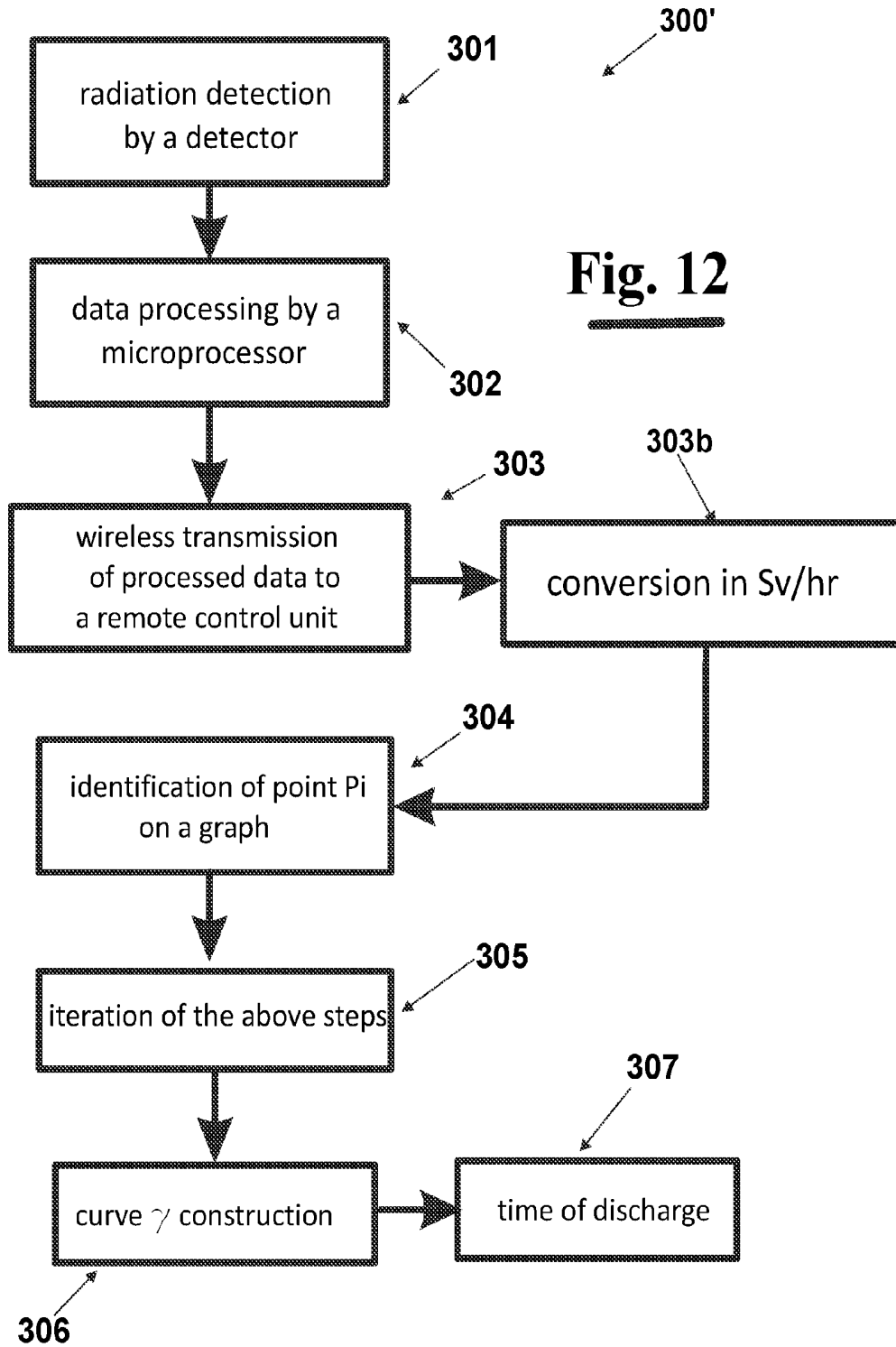
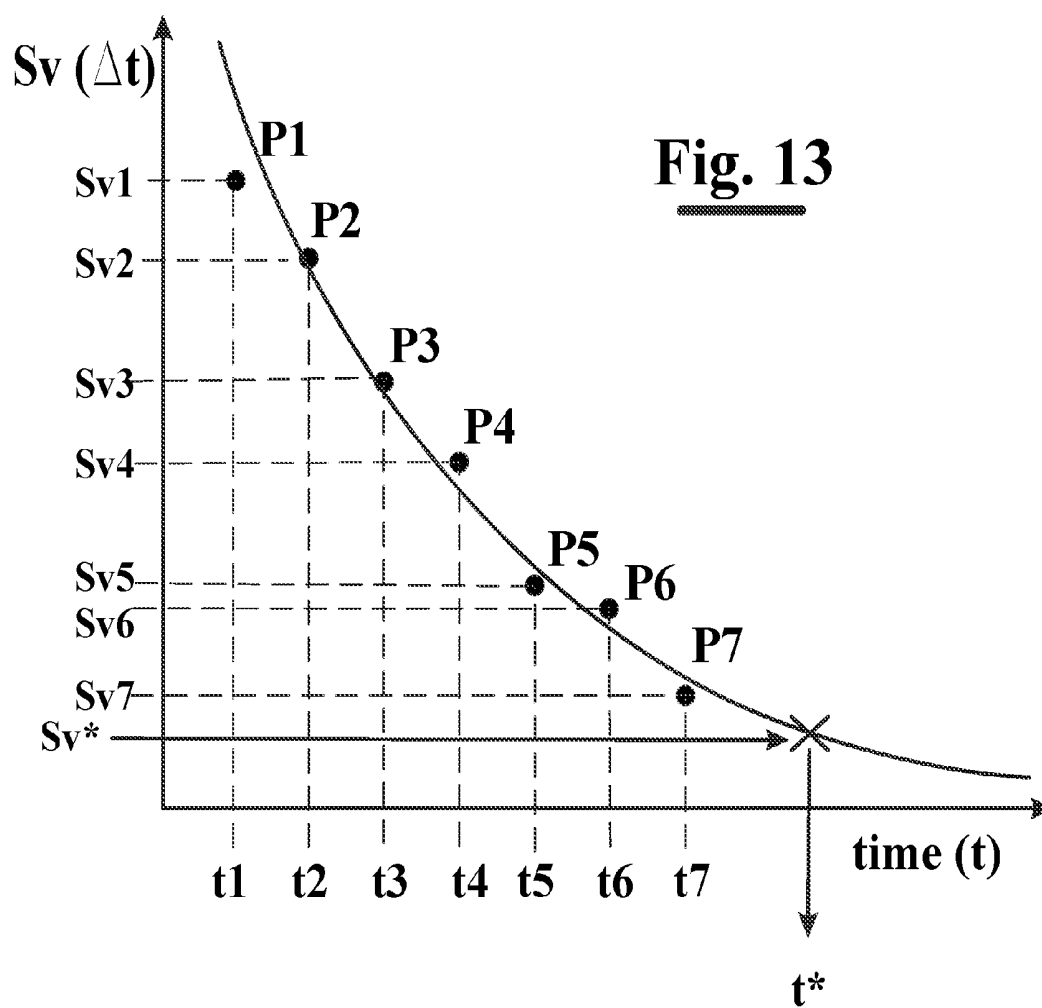

Fig. 10

Fig. 11







**A DEVICE FOR MEASURING A PLURALITY
OF PARAMETERS IN PATIENT SUBJECT TO
A TREATMENT WITH
RADIOPHARMACEUTICALS**

FIELD OF THE INVENTION

[0001] The present invention relates to the medical field, and, in particular, it relates to a device for measuring a plurality of parameters of a patient subject to a treatment with radiopharmaceuticals.

STATE OF THE ART

[0002] As well known, substances like radiopharmaceuticals are administered to patients, usually intravenously but also orally, for diagnostic and/or therapeutic purposes.

[0003] Mainly, radiopharmaceuticals are largely used in oncology, but they are also used in cardiology and neurology, in particular for studying Parkinson and Alzheimer diseases.

[0004] Radiopharmaceuticals are molecules containing at least one radionuclide, i.e. containing radioactive isotopes. Because of radioactive isotopes, radiopharmaceuticals, once administered in a patient can be monitored from the outside, during their specific biological path, by means of specific apparatus. The instruments for detecting the activity make it possible to collect a plurality of consecutive images that depict the radiopharmaceutical distribution in the body, and show the progression of metabolism.

[0005] Normally a radiopharmaceutical has two components: the carrier, i.e. a molecule having biological functions of carrying, and the radioactive nuclide. The carrier allows guiding the radionuclide up to a target organ, or a target system. Through the use of specific diagnostic tools, the nuclides can be followed to determine the distribution of the radiopharmaceutical in the body, evaluating its affinity with target body parts and any variations of the cell biological functions. The radiopharmaceuticals of "diagnostic" type allow then localizing precisely tumour targets and deducing its biological behaviour, and then searching and starting customized therapies.

[0006] In particular, for nuclear medicine, examinations instruments are used capable of detecting the gamma radiations emitted by the nucleotides and precisely positioning the pulses responsive to their source. These instruments are called gamma cameras.

[0007] The technology of the gamma cameras has been developed progressively. From the first analogic systems, which allowed only to record planar images on a plate, recent systems have been developed that are completely digital, which carry out all the planar scintigraphic examinations, static and dynamic, and tomoscintigraphy (SPECT) of high quality and equipped with very fast and powerful processors.

[0008] The instruments that are at present available are single-headed gamma cameras for general use or multiple-headed (double, or triple headed). These are normally preferred since they are able to carry out all the scintigraphic exams, segmental planar and total body and SPECT examinations.

[0009] From the results thus obtained, it is possible to obtain morphological indications of the organs, and data on their functionality. The data that are collected by analysing the image can be used for performing a clinical diagnosis.

[0010] The patients to whom the radiopharmaceuticals have been administered, must remain in insulation for a certain number of days, usually from one to five days, and during their hospitalization they cannot come into contact with their relatives, in particular children and people who are not in perfect health conditions since the radiopharmaceutical is gradually swallowed from the body and therefore the patient's body continues to emit radiations for a determined time from the supply of the same. During the insulation period only the qualified staff of the structure where the patient is hospitalized, i.e. doctors and nurses, have access to the protected chambers of staying in hospital. The radiopharmaceutical is gradually eliminated from the patient's body also owing to its radioactive decay. During the period of time of its decay, small amount are eliminated through the sweat and through the micturition.

[0011] During this period of insulation, the patient is monitored, in such a way to be sure that the radiopharmaceutical is correctly disposed from his/her body and that then he/she is discharged from the structure in which it is hospitalized. Presently, the monitoring of the patient provides some periodic visits that are carried out by a staff member, a nurse, or a doctor, who measures the radiations emitted by the patient's body using a radiation dosimeter, usually a portable Geiger counter. More in detail, at present, in order to carry out the measurements, the staff uses a probe that positions at a certain distance from the patient's body, usually 1.0 m-1.5 m for safety reasons.

[0012] This represents a first limit of this type of detection. In fact, as well known, the intensity of the radiations decreases with the square of the distance. Therefore, this type of procedure is not capable of ensuring a high level of precision in the measuring.

[0013] In addition, in order to avoid that the staff can absorb high amount of radiations, it is necessary to limit to one, two times a day this type of detection. Since the staff members have to check and monitor also other parameters such as arterial pressure, temperature, cardiac frequency, ECG, etc. it is clear that in order to limit the contact of the staff members to the radiations a lot of people have to be involved, or, if this is not possible, the number of the daily detections has to be reduced.

[0014] Therefore, the available data for foreseeing the time of discharge of the patient are few. This makes the forecast not much reliable and, therefore, the time of hospitalization is precautionarily extended and the patient is discharged only when the measured data ensure that the decay proceeding of the radiations is below a predetermined threshold level calculated through tables and statistic measurements.

[0015] For example, in order to increase the number of available data and, therefore to have a more precise picture of the situation, environmental radiation detectors can also be used, i.e. configured to measure the trend of the radiation decay in the room in which the patient is hospitalized.

[0016] A further drawback of the difficulty of determining when the patient subject to treatment with radiopharmaceuticals can be discharged is that it is not possible to optimize the management of the insulation chambers and, then, to extend the waiting time for the patients that must be subject to this type of treatment.

[0017] U.S. Pat. No. 5,007,427 describes a method and an apparatus for determining the exact position of the left ventricle of the heart of a patient. In particular, a device

provides monitoring the heart arranged on a flexible vest that is worn by the patient during the studying period. More in detail, the device for monitoring comprises a main detector of gamma rays and a secondary detector of gamma rays of the type used in the field of the nuclear medicine for monitoring, or diagnosing, the physiological activities of a patient during a predetermined period of time. The procedure described in U.S. Pat. No. 5,007,427, thus, provides to inject a radiopharmaceutical in the circulatory system of the patient to provide an output signal representative of the activity of the left ventricle of the heart. The main detector is adapted to measure the output signal for producing a signal representative of the activity with time of the left ventricle of the heart. Therefore, the system described in U.S. Pat. No. 5,007,427, is not used for determining the time of discharge of a patient subject to radiopharmaceuticals, but has a completely different object.

[0018] In WO2009/127954, in the name of the same applicant, a device is described for supporting a predetermined number of sensors of determined physiological parameters of a patient, such as the arterial pressure. However, WO2009/127954 does not provide a sensor for measuring the radiations emitted by a radiopharmaceutical, nor the document describes a criteria to establish the time of discharge of a patient subject to treatment with radiopharmaceuticals.

SUMMARY OF THE INVENTION

[0019] It is then a feature of the invention to provide a device for measuring a plurality of parameters of a patient subject to treatment with radiopharmaceuticals for carrying out measurements highly precise and ensuring a repeatability of the measure.

[0020] It is also a feature of the invention to provide such a device to avoid that qualified staff, such as nurses, can be hit by the radiations emitted by the patient's body during the detection step.

[0021] It is a further feature of the invention to provide such a device for investigating specific areas of the patient's body, in order to determine in a precise way the status of advancing of the decay of the radioactive particles at the specific investigated area.

[0022] It is a still a feature of the invention to provide such a device to overcome the difficulties of the devices of the state of the art.

[0023] These and other objects are achieved by a multi-parametric device for measuring a plurality of parameters of a patient subject to a treatment with radiopharmaceuticals, said device comprising:

[0024] a main body constrained to the patient's body, in such a way that said measurement device, in use, is worn by the patient;

[0025] a plurality of measurement modules, each measurement module of said plurality equipped with a sensor configured to measure a predetermined parameter of said patient;

[0026] a microprocessor arranged to process a plurality of data measured by said plurality of sensors obtaining a plurality of processed data;

[0027] a wireless transmission means arranged to send via wireless communication said data processed by said microprocessor to a control remote unit;

[0028] a supplier arranged to supply said microprocessor and each sensor of said plurality;

[0029] engagement means arranged to engage with respective engagement means of each measurement module of said plurality, said engagement means arranged to operatively connect said microprocessor with each sensor of said plurality;

[0030] whose main feature is that at least one measurement module of said plurality is a measurement module of radiations equipped with a radiation sensor configured to measure said radiations in a predetermined time range Dt;

[0031] and that said measurement module is configured to arrange at a short distance from the patient's body in such a way that said radiation sensor is arranged to measure the radiations emitted by the radiations source from a short and substantially fixed distance;

[0032] and that said control unit is arranged to carry out a processing procedure of the processed data for determining the time of discharge of the patient subject to the pharmacological treatment.

[0033] The technical solution provided by the present invention of using a multi-parametric device avoids that medical, or paramedical, staff enters frequently in the room where the patient is hospitalized for carrying out the measurement of the parameters to be monitored such as arterial pressure, temperature, cardiac frequency, etc. This way, therefore, it is avoided that the staff can be repeatedly hit by the radiations emitted by the patient's body. Furthermore, the possibility to avoid the use of medical and paramedical staff for carrying out the measurements carries out frequently such detection without the drawback to put to risk the safety of the staff.

[0034] In particular, the radiation sensor is adapted to emit an impulse, or "spike", for each detection of radiations emitted by the patient. More in detail, the radiation sensor emits a pulse when detects a radiation associated with an energy higher than a predetermined value.

[0035] In particular, the microprocessor, operatively connected to the sensor, is adapted to count the number of pulses emitted by the radiation sensor in a predetermined time range Dt1 obtaining the number of pulses in time range n(Dt1).

[0036] Then, the number of pulses n(Dt₁) that have been counted by the microprocessor is sent to the remote control unit by the wireless transmission. The control unit is adapted to associate a point P(Dt₁) responsive of the number of pulses n(Dt₁) on a diagram n(Dt₁) versus time (t). The above described succession of steps is repeated a predetermined number of times up to cover a predetermined time of observation. More in detail, once that the overall time of observation t_{tot} has been decided, for example 24 hours, and the detection time Dt₁, the time range Dt₂ between a detection and the following one is established. For each range Dt_i the number of pulses emitted by the radiation sensor is calculated when radiations higher than a predetermined energy value are detected and plotted on a diagram.

[0037] In particular, the control unit is arranged to carry out a processing procedure comprising the steps of:

[0038] constructing a characteristic curve g representative of the number of radiations detected by said sensors of radiations in function of the time;

[0039] determining the time t at which said curve g assumes a value equal, or lower, than a predetermined lower threshold value t*, said time t corresponding to the time of discharge of the patient.

[0040] In particular, the construction of the characteristic curve g provides the steps of:

[0041] counting the number of pulses emitted by said radiation sensor to detect said radiations in a predetermined time range Δt_1 obtaining the number of pulses in said time range $n(\Delta t_1)$;

[0042] identifying a point representative of said number of pulses $n(\Delta t_1)$ on a diagram $n(\Delta t_1)$ versus time (t);

[0043] repeating said counting step and said identifying step for a predetermined number k of time ranges Δt_1 spaced from the following of a second predetermined time range Δt_2 for an overall time of detection Dt_{tot} at the end of said repeating step being determined of the number k of particles radioactive in a predetermined time range $n_i(Dt_1)$, with $i=1 \dots k$ and defined on said graph a corresponding number k of points P_i ;

[0044] constructing on said graph said characteristic curve g through said plurality of points P_i , each point P_i of said plurality corresponding to a number of pulses $n_i(Dt_1)$ counted at the i -th second time range Δt_2 ;

[0045] determining said time of discharge td of the patient from said characteristic chart g , through the steps of:

[0046] comparing said characteristic chart g built with a plurality of predetermined calibration curve;

[0047] selecting among said plurality of calibration curve of the curve g^* that better approximates said built characteristic chart g ;

[0048] identifying on said selected calibration curve g^* the time t at which said curve g^* assumes a value equal, or lower, than said predetermined lower threshold value $n^*(Dt_1)$.

[0049] Advantageously, the engagement means of each measurement module and the engagement means of the main body are adapted to provide a matching form. In particular, the engagement means is configured to recognizing each module.

[0050] In particular, in addition to the measurement module of the radiations emitted by the patient's body, at least one measurement module is provided selected from the group consisting of:

[0051] a measurement module configured to measure the arterial pressure;

[0052] a measurement module configured to measure the cardiac frequency;

[0053] a measurement module configured to measure SpO_2 ;

[0054] a measurement module configured to measure the position;

[0055] a measurement module configured to measure the temperature;

[0056] a measurement module configured to measure the ECG 4 derivations;

[0057] a measurement module configured to measure the breath frequency;

[0058] or a combination thereof.

[0059] Advantageously, the control unit is adapted to carry out a digital filtering of said plurality of data transmitted via wireless communication by said microprocessor. This way, it is possible to reduce, through a digital filtering, noises of the signal, i.e. the possible distortion owing to the wireless transmission.

[0060] Advantageously, the measurement module of the radiations has a shielding element arranged to insulate said

radiation sensor from said wireless transmission means. In fact, the wireless transmission could interfere with the detection of the radiations by the radiation sensor. Instead, the technical solution of providing the shielding element makes it possible to insulate the sensor from the wireless transmission means and therefore to avoid said drawbacks.

[0061] In particular, the shielding element is a thin plate of predetermined thickness of a metal material, for example aluminium.

[0062] Preferably, the radiation sensor is a solid state sensor. Such a solution allows reducing its size and ensuring in the meantime precise measurements of the energy associated with the radiations emitted by the patient's body. Therefore, the choice of using a solid state sensor is particularly advantageous in the case of a measurement device of wearable type.

[0063] In a advantageous exemplary embodiment the measurement device comprises:

[0064] a first measurement module of radiations, said measurement module equipped with a first radiation sensor configured to measure a first plurality of radiation data at a first analysis zone of the patient's body;

[0065] at least a second measurement module of radiations, said second measurement module equipped with a second radiation sensor configured to measure a second plurality of radiation data at a second zone of analysis of the patient's body.

[0066] This exemplary embodiment allows, in particular, of monitoring with a single multi-parametric device the radiations emitted by the patient's body in two different points, in particular at a first organ and a second organ of the patient, for example at the thyroid and the liver. This way, it is also possible to evaluate if the radiations induced by the radiopharmaceutical involves in addition to the element subject to treatment with radiopharmaceuticals also other areas, i.e. organs, or tissues of the patient's body, by the measurement of the radiations emitted near the parts of interest. This allows to have a more complete picture of the physical conditions of the patient.

[0067] According to another aspect of the invention a measurement module of the radiations emitted by the body of a patient subject to treatment with radiopharmaceuticals, said modular portion comprises:

[0068] a radiation sensor configured to measure said radiations in a predetermined time range;

[0069] engagement means arranged to engage said module to respective engagement means of a multi-parametric modular device, said multi-parametric modular device being configured to be worn by a patient in such a way that said radiation sensor is adapted to measure the radiations emitted by the patient's main body maintaining substantially fixed the distance from the source of radiations, said multi-parametric modular device comprising:

[0070] a microprocessor configured to process said plurality of radiation data measured by said measuring module obtaining a plurality of processed data;

[0071] wireless transmission means arranged to send via wireless communication said data computed by said microprocessor to a remote control unit;

[0072] a supplier arranged to supply said microprocessor and said radiation sensor.

[0073] Advantageously, the multi-parametric measurement device comprises a display on which are displayed the main parameters measured by the sensors to it connected.

[0074] In particular, it is possible to provide a plurality of measurement modules of radiations of different type. In particular, each measurement module of the radiations is equipped with a sensor of different type, i.e. sensitive to a predetermined range of radiations. For example, a criteria that can be used for selecting a measurement module of the radiation with respect to another can be to evaluate which radiopharmaceutical has been used. In function of the radiopharmaceutical that has been used, in fact, the radionuclide incorporated in it, i.e. the radioactive isotope, has a predetermined time of decay and firstly emits radiations in a specific range of energy. Therefore, the radiation sensor is selected on the basis of the type of radiopharmaceutical used.

[0075] According to a further aspect of the invention, a measurement device of radiations emitted by the body of a patient subject to treatment with radiopharmaceuticals is configured to can be of a type wearable and provides:

[0076] a solid state radiation sensor configured to measure the radiations in a predetermined time range and to provide a corresponding plurality of radiation data;

[0077] a microprocessor configured to process said plurality of radiation data measured by said sensor obtaining a plurality of processed data.

[0078] Advantageously, a transmitting means is also provided of wireless type arranged to send through wireless communication said data computed by said microprocessor to a remote control unit.

[0079] Furthermore, the device provides a supplier arranged to supply the microprocessor and the radiation sensor.

[0080] In particular, a support can be provided for the measurement device arranged to be constrained to the patient's body and then of making the measurement device of the radiations of wearable type as described above.

BRIEF DESCRIPTION OF THE DRAWINGS

[0081] The invention will be now shown with the following description of its exemplary embodiments, exemplifying but not limitative, with reference to the attached drawings in which:

[0082] FIG. 1A diagrammatically shows a first exemplary embodiment of a wearable device, according to the invention, for measuring radiations emitted by a patient subject to treatment with radiopharmaceuticals;

[0083] FIG. 2A diagrammatically shows an exemplary embodiment of the device of FIG. 1A;

[0084] FIG. 1B diagrammatically shows a first exemplary embodiment of a multi-parametric device, according to the invention, for measuring a plurality of parameters of a patient subject to treatment with radiopharmaceuticals;

[0085] FIG. 2B diagrammatically shows an exemplary embodiment of the multi-parametric device of FIG. 1B;

[0086] FIG. 3 diagrammatically shows a top plan view of a possible exemplary embodiment of the multi-parametric device of FIG. 1B;

[0087] FIG. 4 shows the device multi-parametric of FIG. 3 a perspective view of;

[0088] FIG. 5 diagrammatically shows a block diagram in which the main components are indicated of the multi-parametric device according to the invention;

[0089] FIGS. 6 and 7 show in top plan views two possible exemplary embodiments of the invention of FIG. 3;

[0090] FIG. 8 diagrammatically shows a further exemplary embodiment of the device of FIG. 1B applied to a patient;

[0091] FIG. 9 shows the exemplary embodiment of FIG. 8 in a top plan view of highlighting some technical features;

[0092] FIG. 10 shows a block diagram of a procedure that can be carried out with the device according to the present invention in order to determine in how long time the patient disposes the radiopharmaceutical and then can be discharged from the building where it is hospitalized;

[0093] FIG. 11 shows the curve for determining the time of discharge that can be constructed through the succession of steps shown in the block diagram of FIG. 10 reproduced on a diagram: number of pulses in the time range in function of the time;

[0094] FIG. 12 shows a block diagram of a procedure similar to that one of FIG. 10 that can be carried out with the device according to the present invention but in which the number of pulses counted by the microprocessor is converted in Siever/hr;

[0095] FIG. 13 shows the curve for determining the time of discharge that is obtained if a conversion of the data in Siever/hr is provided according to the succession of operations shown in FIG. 12.

DETAILED DESCRIPTION OF THE INVENTION

[0096] With reference to FIGS. 1A and 2A, a measurement device 70 for measuring the radiations emitted by the body of a patient 50 subject to a treatment with radiopharmaceuticals is configured in such a way that it can be of wearable type and comprises, in particular, a solid state radiation sensor 110 configured to measure the radiations in a predetermined time range and to provide a corresponding plurality of radiation data. Furthermore, a microprocessor 150 is provided configured to process the above described plurality of radiation data that have been measured by the sensor 110 obtaining a plurality of processed data. The invention provides, advantageously, transmission means of wireless type arranged to send via wireless communication the above described data processed by the microprocessor 150 to a remote control unit. Furthermore, the device 70 provides a supplier arranged to supply the microprocessor 150 and the solid state radiation sensor 110. In particular, a support 105 can be provided for the measurement device 70 arranged to be constrained to the patient's body and then to make the measurement device of radiations of wearable type as above described.

[0097] As shown in detail in FIGS. 1B, 2B, 3 and 4, said measurement device 70 of radiations can be advantageously configured as a module of a multi-parametric device 100 for measuring a plurality of parameters of a patient subject to a treatment with radiopharmaceuticals. More in detail, the multi-parametric device, thus obtained, comprises a main body 101 constrained to the patient's body 50 in such a way that the measurement device 100 is of wearable type. For example, the main body 101 can comprise a box-like body 102 mounted on a belt 105 that is constrained to the thorax of the patient 50 (FIG. 1B), or on a bracelet 105' that is constrained to the wrist of the patient 50 (FIG. 2B).

[0098] As shown in detail in FIGS. 3 and 4, the device 100 comprises a plurality of measurement modules, for example

a first module **70** and a second module **71**, each of which has a respective sensor **110**, **111**, configured to measure a predetermined parameter of the patient **50**. Even though in FIGS. **3** and **4** the two measurement modules **70** and **71** are shown connected to a same side of the measurement device **100** it is however also provided that the same modules can be arranged on different sides of the main body **101**. Therefore, the device **100** is a multi-parametric device of modular type.

[0099] The device **100** is also provided with a microprocessor **150** configured to process a plurality of data measured by the plurality of sensors **110**, **111**, obtaining a plurality of processed data. Furthermore, a transmission means is furthermore provided of wireless type arranged to send via wireless communication the data processed by the microprocessor **150** to a remote control unit **250**. For example, the wireless transmission can be made by means of a Bluetooth module **75** and/or a wifi module **85**, or other types of wireless communication. Furthermore, it is provided a supplier **160**, for example a rechargeable battery, arranged to supply the microprocessor **150**, each sensor **110**, **111**, and other electronic components.

[0100] In particular, each measuring module **70**, **71** engages with the main body **102** by engagement means **170**, **171** arranged to engage with respective engagement means **172** of the hollow container body **102**. More in detail, the engagement means **170**, **171** and **172** are adapted to operatively connect the microprocessor **150** with each sensor **70**, **71** engaged to the main body **102**. The engagement means **170**, **171** and **172** can be electric connection elements of known type.

[0101] According to the invention, the device **100** provides at least one measurement module of radiations **70**. This is equipped with a sensor of radiations **110** configured to measure the radiations emitted by the patient's body in a predetermined time range Dt .

[0102] The radiation sensor **110** is preferably a solid state sensor. Such solution allows to reduce its size and to ensure, in the meantime, precise measurements of the energy associated with the radiations emitted by the patient's body. Therefore, the choice of using a solid state sensor is particularly advantageous in case of a measurement device of wearable type.

[0103] The basic idea of the present invention, i.e. of using a measurement module **70** of radiations connected to the main body **102** constrained to the patient's body **50** allows to carry out a detection from a short distance from the patient's body **50**. Therefore, the radiation sensor **110** is adapted to measure the radiations emitted by the source of radiations from a short distance and substantially fixed and therefore highly precise, which is localized and reliable. In fact, as well known, the radiation energy is in inverse relation with the square of the distance. Therefore, reducing, with respect to the prior art devices, the distance between the radiation detector and the source of radiations, i.e. the patient's body **50** treated with radiopharmaceuticals, it is possible to increase the precision level of the measurement.

[0104] Still according to the invention, in addition to the measurement module of the radiations **110** emitted by the patient's body **50**, at least one measurement module is provided selected from the group consisting of: a module for measuring the arterial pressure, a module for measuring the cardiac frequency, a module for measuring SpO₂, a module for measuring the position, a module for measuring the

temperature, a module for carrying out the ECG, in particular ECG 4 derivation, a module for measuring the frequency breath or any combination thereof. The technical solution provided by the present invention of using a multi-parametric device **100** avoids that medical, or paramedical, staff enters frequently in the room in which the patient is hospitalized for carrying out the measurement of the parameters to be monitored such as arterial pressure, temperature, cardiac frequency, breath frequency etc. This way, therefore, it is avoided that the staff are repeatedly hit by the radiations emitted by the patient's body. Furthermore, the possibility to avoid the use of medical and paramedical staff for carrying out the measurements carries out frequently such detection without the drawback to put in risk the safety of the staff.

[0105] More in detail, the radiation sensor **110** is adapted to emit an impulse, or "spike", at each detection of radiations emitted by the patient **50**. More in detail, the radiation sensor **110** emits a pulse when it detects a radiation associated with an energy higher than a predetermined value. The microprocessor **150**, operatively connected to the sensor **110**, is adapted to carry out a count of the number of pulses emitted by the radiation sensor **110** in a predetermined time range Dt_1 obtaining the number of pulses emitted by the sensor **110** in the considered time range $n(Dt_1)$.

[0106] Then, the number of pulses $n(Dt_1)$ counted by the microprocessor **150** is sent to the remote control unit **300** from the above described wireless transmission, for example by means of Bluetooth, or wifi. The control unit **250** is adapted, in particular, to associate a point $P(Dt_1)$ representative of the number of pulses $n(Dt_1)$ on a diagram $n(Dt_1)$ versus time (t). The above described succession of steps is repeated a predetermined number of times up to cover a predetermined time of observation. More in detail, once the overall time of observation t_{tot} has been decided, for example 24 hours, and each time of detection Dt_1 , the time range Dt_2 between a detection and the subsequent one is decided. For each time range Dt_1 the number of pulses emitted by the radiation sensor **110** is computed when radiations are detected that are higher than a determined energy and reproduced on a graph. An example of a graph obtainable through the above described processing is diagrammatically shown in FIG. **8**. A further advantage of the present invention is that it is possible to carry out many measurements, in particular in predetermined instants, and in such a way to have a repeatability of the measure that further increases the reliability of the measure and then of the estimate of the time of discharge of the patient that has been measured through the procedure above described.

[0107] The mutual engagement means **170**, **171** of each measurement module **70**, **71** and the mutual engagement means **172** of the main body **102** can be arranged to provide a positive engagement. In particular, the engagement means can be configured to be capable of recognizing each module, i.e. to avoid an engagement between a module and the main body **101** at a wrong connection port, i.e. not adapted to operatively connect the module connected with the main body to the microprocessor. This can be obtained through mutual engagement means that is arranged to provide a positive engagement between the module and the main body. In this case the mutual engagement means **170**, **171** and **172** in addition to ensure an electric connection between each sensor **110**, **111** and the microprocessor **150** are also adapted to ensure that the mechanical connection between each module **70**, **71** and the main body **101** of the multi-para-

metric device **100** occurs correctly. This can be made for example as described in WO2009127954 in the name of the same applicant. The engagement means **172** can be configured to recognize the module **70,71**, i.e. to avoid that a module **70,71** is connected to the main body **101** at a wrong connection port.

[0108] According to an exemplary embodiment, the control unit **250** can carry out a digital filtering of the data transmitted via the above described wireless communication. This way, it is possible to reduce through a digital filtering noises of the signal, i.e. the possible distortion delivered during the wireless transmission. In particular, the digital filtering is adapted eliminate the irregular spike, i.e. not corresponding to an event really occurred, in other words to a detection of radiations by the radiation sensor **110**, but to a noise produced by the interference with the signal of the wireless transmission.

[0109] In addition, or alternatively, to the digital filtering, in order to remedy said disadvantage, i.e. the interference between the signal of the wireless transmission and the detection of the radiations by the sensor **110**, the module **70** can be equipped with a shielding element **90** arranged to insulate the radiation sensor **110** from the wireless transmission means. Such a solution provides then to interpose a physical barrier between the radiation sensor **110** and the antenna that transmits the data wirelessly. The shielding element **90** can be a thin plate of predetermined thickness of a metal material, for example aluminium.

[0110] As diagrammatically shown in FIGS. **8** and **9**, in a advantageous exemplary embodiment, the measurement device **100** comprises a first measurement module **70a** of the radiations and at least one second measurement module **70b** of the radiations. Each measurement module **70a, 70b**, is equipped with a respective radiation sensor **110a** and **110b**. More in detail, the sensor **110a** is adapted to measure a first plurality of radiation data at a first zone of analysis **200a** of the patient's body **50**, for example in the zone surrounding the carotid. The second module **70b** equipped with a second radiation sensor **110b** is, instead, configured to measure a second plurality of radiation data at a second zone of analysis **200b** of the patient's body **50**, for example at the liver. In this exemplary embodiment, each measurement module **70a, 70b**, is advantageously connected to the main body **102** and after microprocessor **150** by a respective connection cabled **87a, 87b**. In this case each module **87a, 87b** can be provided mounted to an adhesive element, for example a suction cap **88a, 88b**, of the type used for ECG, in such a way to be engaged at the respective area of analysis **200a, 200b**.

[0111] This exemplary embodiment allows, in particular, to monitor with a single multi-parametric device **100** the radiations emitted by the patient's body in two different points. This way, it is also possible to consider if the radiations induced by the radiopharmaceutical in the patient involves, in addition to the organ subject to treatment with radiopharmaceuticals, also other areas, i.e. other organs, or tissues of the patient's body, by the measurement of the radiations emitted near the interested parts. This way, it is possible to have a more complete picture of the physical conditions of the patient.

[0112] The multi-parametric measurement device **100** can also have a display **95** on which the main parameters measured by the sensors **110, 111** to it connected are displayed. Even though in FIG. **10** the display **95** is shown

connected by a wire **87c** to the main body **102** it is also provided that it can be integrated in the main body **102** same.

[0113] With reference to the block diagram **300** of FIG. **10**, the measurement device of wearable type **100**, according to the present invention as described with reference to FIGS. **1** to **10**, can be used for determining the time of discharge of a patient **50** subject to a treatment with radiopharmaceuticals.

[0114] More in detail, as shown with reference to the scheme **300** of FIG. **10**, a detecting step is provided by the radiation sensor **110** of the radiations emitted by the patient's body **50** in a first predetermined time range Dt_1 obtaining a plurality of measured data, block **301**.

[0115] The detected data are then processed by a microprocessor **150** that carries out the counting of the number of pulses emitted by the detector device when the radiations in a first predetermined time range Dt : are detected, block **302**. More in detail, if the first time range Dt : is chosen equal to 1 minute, the number of pulses $n(Dt_1)$ is expressed in c.p.m., i.e. "count for minute", or equivalent counts. In practice the number of pulses in said time range corresponds to the energy associated with the detected radiations. As described above, each datum detected by the radiation sensor **110** and processed by the microprocessor **150** is sent via wireless communication to a control unit **250**, block **303**. The control unit **250** provides then to plot the received processed data on a graph (number of pulses vs time) identifying a corresponding point P_i , block **304** (see for example FIG. **11**).

[0116] The detecting and processing steps are then repeated for a predetermined number k of time range Dt_1 with a delay of a second predetermined time range Dt_2 from the following one for a predefined overall time of observation t_{tot} , block **305**.

[0117] At the end of the iteration a predetermined number k of numbers of pulses is determined in each predetermined time range $n_i(Dt_1)$, with $i=1 \dots k$ and then a corresponding number k of points P_i is identified on the graph.

[0118] Once the above described k points P_i have been identified it is possible to proceed with the construction on the graph of a characteristic chart g , block **306**. By the characteristic chart g it is possible to determine the time of discharge t_d of the patient. More in detail, the determination of the time of discharge t_d can be carried out identifying on the graph on which the characteristic chart g has been reproduced, a lower threshold value $n^*(Dt_1)$ and then from the curve g the time of discharge t^* that corresponds to the time t at which the curve g assumes a value equal, or less than said lower threshold value. An example of this procedure is diagrammatically shown in FIG. **11**.

[0119] The above disclosed lower threshold value can be for example determined through a comparison, for example carried out by the control unit **250**, of the characteristic chart g constructed with a plurality of predetermined calibration curve loaded in a special database. Between the above described plurality of calibration curve is selected the curve g^* that better approximates the constructed characteristic chart g . At last, on the above described calibration curve g^* the time t is selected at which the curve g^* , and then within a certain margin of uncertainty also the curve g , assumes a value equal, or lower, than the predetermined lower threshold value $n^*(Dt_1)$.

[0120] More in detail, the calibration curve loaded in the database are curve constructed using known coefficient, i.e. parameters. The coefficient to be considered can be weight

of the patient, age of the patient, type of radiopharmaceutical that has been used, type of diseases of the patient, or more in general a combination of these parameters. Therefore a first selection of the calibration curve that can be used is carried out on the basis of the identity, or the likeness, of the values of the above described parameters, or coefficient, with those of the patient. Then, among the curves that have passed the first selection it is selected the curve that has a trend similar to that one of the characteristic chart g.

[0121] As diagrammatically shown in FIG. 11, the construction step of the characteristic chart g can provide an interpolation step of the points P_i , in such a way that it is possible to determine with large advance, i.e. once recorded the data relative to a first period of observation, such as it is the time of discharge. Since many data are available, the interpolation allows to provide a curve highly reliable. This is a further advantage of the use of a detector device of wearable type.

[0122] In the exemplary embodiment shown diagrammatically view of FIG. 12 it is also provided a conversion step of each number of pulses calculated in each time range Δt_1 , for example 1 min, in a measure in Sievert/hr (Sv/hr), block 303b. Such a conversion can be carried out using the known curve of conversion. For example, the conversion can be necessary if the lower threshold values are expressed in Sievert/hr (Sv/hr).

[0123] In this case, therefore, the graph that is constructed is Sv/hr versus time (FIG. 13).

[0124] The foregoing description exemplary embodiments of the invention will so fully reveal the invention according to the conceptual point of view, so that others, by applying current knowledge, will be able to modify and/or adapt for various applications such embodiment without further research and without parting from the invention, and, accordingly, it is therefore to be understood that such adaptations and modifications will have to be considered as equivalent to the specific embodiments. The means and the materials to realise the different functions described herein could have a different nature without, for this reason, departing from the field of the invention. It is to be understood that the phraseology or terminology that is employed herein is for the purpose of description and not of limitation.

1. Multiparametric device (100) for measuring a plurality of parameters of a patient (50) subject to a treatment with radiopharmaceuticals, said device (100) comprising:

- a main body (101) constrained to the patient's body (50), in such a way that said device (100) for measuring, in use, is worn by the patient (50);
- a plurality of measurement modules (70,71), each measurement module (70,71) of said plurality equipped with a sensor (110,111) configured to measure a predetermined parameter of said patient (50);
- a microprocessor (150) configured to process a plurality of data measured by said plurality of sensors (110,111) obtaining a plurality of processed data;
- a wireless transmission means (75,85) arranged to send via wireless communication said data processed by said microprocessor (150) to a remote control unit (250);
- a supplier arranged to supply said microprocessor (150) and each sensor (110,111) of said plurality;
- engagement means (170,171) arranged to engage with respective engagement means (172) of each measurement module (70,71) of said plurality, said engagement

means arranged to operatively connect said microprocessor (150) with each sensor (110,111) of said plurality;

said multi-parametric modular device (100) characterized in that at least one measurement module (70) of said plurality is a measurement module (70) of radiations equipped with a radiation sensor (110) configured to measure said radiations in a predetermined time range Δt ;

in that said measurement module (70,71) is configured to be arranged at a short distance from the patient's body (50) in such a way that said radiation sensor (110) is arranged to measure the radiations emitted by the source of radiations from a short and substantially fixed distance; and

in that said control unit (250) is arranged to carry out a processing procedure of said processed data for determining the time of discharge t_d of said patient subject to said pharmacological treatment.

2. Device (100), according to claim 1, wherein said processing procedure comprises the steps of:

constructing a characteristic chart g representative of the number of radiations detected by said sensors of radiations in function of the time;

determining the time t at which said curve g assumes a value equal, or lower, than a predetermined lower threshold value t^* , said time t corresponding to the time of discharge of the patient.

3. Device (100), according to claim 2, wherein said constructing step of said characteristic chart g provides the steps of:

counting the number of pulses emitted by said radiation sensor when said radiations are detected in a predetermined time range Δt_1 obtaining the number of pulses in said time range $n(\Delta t_1)$;

identifying a point representative of said number of pulses $n(\Delta t_1)$ on a graph $n(\Delta t_1)$ versus time (t);

repeating said counting step and said identifying step for a predetermined number k of time range Δt_1 with a delay one from the subsequent one of a second predetermined time range Δt_2 for an overall time of detection Δt_{tot} , at the end of said repeating step being determined the number k of radioactive particles in a predetermined time range $n_i(\Delta t_1)$, with $i=1 \dots k$ and identified a corresponding number k of points P_i on said graph;

constructing of said characteristic chart g on said graph through said plurality of points P_i , each point P_i of said plurality corresponding to a number of pulses $n_i(\Delta t_1)$ counted at a i-th second time range Δt_2 ;

determining said time of discharge t_d of the patient from said characteristic chart g, through the steps of:

comparing said constructed characteristic chart g with a plurality of predetermined calibration curve;

selecting among said plurality of calibration curve of the curve g^* which better approximates said constructed characteristic chart g;

identifying on said selected calibration curve g^* the time t at which said curve g^* assumes a value equal, or lower, than said predetermined lower threshold value $n^*(\Delta t_1)$.

4. Device (100), according to claim 1, wherein said engagement means (170,171) of each of said measurement module (70,71) and said engagement means (172) of said main body (101) are arranged to provide a positive engage-

ment, said engagement means (172) being configured to recognize said module (70,71), i.e. to avoid that a module (70,71) can be connected to said main body (101) at a wrong connection port.

5. Device (100), according to claim 1, wherein, in addition to said measurement module (70) for measuring the radiations emitted by the patient's body (50), at least one measurement module (71) is further provided selected from the group consisting of:

- a measurement module configured to measure the arterial pressure;
- a measurement module configured to measure the cardiac frequency;
- a measurement module configured to measure SpO₂;
- a measurement module configured to measure the position;
- a measurement module configured to measure the temperature;
- a measurement module configured to measure the ECG 4 derivations;
- a measurement module configured to measure the frequency breath;
- or a combination thereof.

6. Device (100), according to claim 1, wherein said remote control unit (250) is arranged to carry out a digital filtering of said plurality of data transmitted via wireless communication from said microprocessor (150), said digital filtering arranged to reduce noises, i.e. possible distortions owing to the wireless transmission of the signal associated with said plurality of data.

7. Device (100), according to claim 1, wherein said measurement module (70) of the radiations is provided with a shielding element (90) arranged to insulate said sensor (110) of radiations from said wireless transmission means, in order to avoid interferences between the wireless transmission and the detection of radiations carried out by the radiation sensor.

8. Device (100), according to claim 6, wherein said shielding element (90) is a thin plate of predetermined thickness made of a metal material.

9. Device (100), according to claim 7, wherein said metal material is aluminium.

10. Device (100), according to claim 1, wherein said radiation sensor (110) is a solid state sensor, in such a way to allow to reduce its size and to ensure at the same time precise measurements of the energy associated with the radiations emitted by the patient's body (50).

11. Device (100), according to claim 1, comprising:

- a first measurement module (70a) of the radiations, said first module (70a) equipped with a first radiation sensor (110a) configured to measure a first plurality of radiation data at a first zone of analysis (200a) of the patient's body (50);

at least a second measurement module (70b) of the radiations, said second measurement module (70b) equipped with a second radiation sensor (110b) configured to measure a second plurality of radiation data at a second zone of analysis (200b) of the patient's body (50).

12. Device (100), according to claim 1, wherein said radiation sensor (110) is arranged to emit an impulse, or "spike", at each detection of radiations emitted by the patient (50) and said microprocessor (150) is arranged to count the number of pulses emitted by said radiation sensor in a predetermined time range Dt_1 obtaining the number of pulses in said time range $n(Dt_1)$.

13. Measurement device of radiations (70) emitted by the body of a patient (50) subject to a treatment with radiopharmaceuticals, said device (70) characterized in that it is configured in such a way that it can be of wearable type;

and in that it provides:

- a solid state radiation sensor (110) configured to measure said radiations in a predetermined time range and to provide a corresponding plurality of radiation data;
- a microprocessor (150) configured to analyse said plurality of data of waves measured by said solid state sensor (110) obtaining a plurality of processed data;
- a wireless transmission means (75,85) arranged to send via wireless communication said data processed by said microprocessor (150) to a remote control unit (250);
- a supplier arranged to supply said microprocessor (150) and said radiation sensor (110).

14. Device (100), according to claim 13, characterized in that it comprises a display on which said main parameters measured by said sensors that are connected to it are displayed.

15. Device (100), according to claim 13, wherein a plurality of measurement modules of radiations of different type is provided, each measurement module of radiations having a radiation sensor sensitive to a predetermined range of radiations different from that one of the other sensors of radiations.

16. Device (100), according to claim 1, characterized in that it comprises a display on which said main parameters measured by said sensors that are connected to it are displayed.

17. Device (100), according to claim 1, wherein a plurality of measurement modules of radiations of different type is provided, each measurement module of radiations having a radiation sensor sensitive to a predetermined range of radiations different from that one of the other sensors of radiations.

* * * * *

专利名称(译)	一种用于测量受放射性药物治疗的患者的多个参数的装置		
公开(公告)号	US20170007177A1	公开(公告)日	2017-01-12
申请号	US15/116330	申请日	2015-02-16
[标]申请(专利权)人(译)	温麦迪科责任有限公司		
申请(专利权)人(译)	WINMEDICAL S.R.L.		
当前申请(专利权)人(译)	WINMEDICAL S.R.L.		
[标]发明人	VALDASTRİ PIETRO DE NEGRI FERDINANDO		
发明人	VALDASTRİ, PIETRO DE NEGRI, FERDINANDO		
IPC分类号	A61B5/00 G06F19/00 A61B6/00 A61N5/10 A61B5/0205		
CPC分类号	A61B5/4848 A61B5/14542 A61B5/6823 A61B5/6824 A61N5/1071 A61N5/1075 A61B5/02055 A61B5/7203 A61B6/42 A61B6/463 G06F19/3481 G06F19/3406 G06F19/3437 A61N2005/1021 A61B2560/0456 A61B2562/06 A61B2562/18 A61B5/021 A61B5/02438 A61B5/0402 A61B5/0816 A61B5/11 A61B5/002 A61B5/48 A61B5/6801 A61N5/1001 A61N2005/1092 A61N2005/1094 G16H40/63 G16H50/50		
优先权	102014902234121 2014-02-17 IT		
外部链接	Espacenet USPTO		

摘要(译)

一种用于测量经受用放射性药物治疗的患者的多个参数的装置，包括被限制到患者身体的主体，使得测量装置是可佩戴型的。该装置包括多个测量模块，例如第一模块和第二模块，每个测量模块配备有相应的传感器，其被配置为测量患者的预定参数。该装置还配备有微处理器，其被配置为处理由多个传感器测量的多个数据，获得多个处理的数据。此外，提供无线类型的传输装置，其被布置为经由无线通信将由微处理器处理的数据发送到远程控制单元。

