



US 20150374292A1

(19) **United States**
(12) **Patent Application Publication**
WYETH et al.

(10) **Pub. No.: US 2015/0374292 A1**
(43) **Pub. Date: Dec. 31, 2015**

(54) **DETECTION AND ANALYSIS OF SPATIALLY VARYING FLUID LEVELS USING MAGNETIC SIGNALS**

(71) Applicant: **CEREBROTECH MEDICAL SYSTEMS, INC.**, Pleasanton, CA (US)

(72) Inventors: **Richard Warren WYETH**, Discovery Bay, CA (US); **Mitchell Elliott Levinson**, Pleasanton, CA (US); **Bryan Jon Weber**, Livermore, CA (US); **Eugene Mark Shusterman**, Pleasanton, CA (US); **Boris Rubinsky**, El Cerrito, CA (US)

(21) Appl. No.: **14/844,681**

(22) Filed: **Sep. 3, 2015**

Related U.S. Application Data

(63) Continuation-in-part of application No. 14/690,985, filed on Apr. 20, 2015, which is a continuation of application No. 14/275,549, filed on May 12, 2014, now abandoned, which is a continuation of application No. 13/745,710, filed on Jan. 18, 2013, now Pat. No. 8,731,636.

(60) Provisional application No. 61/588,516, filed on Jan. 19, 2012, provisional application No. 62/131,882, filed on Mar. 12, 2015, provisional application No. 62/048,690, filed on Sep. 10, 2014, provisional application No. 62/045,044, filed on Sep. 3, 2014.

Publication Classification

(51) **Int. Cl.**
A61B 5/00 (2006.01)
A61B 5/0452 (2006.01)
A61B 5/03 (2006.01)
A61B 5/04 (2006.01)
(52) **U.S. Cl.**
CPC *A61B 5/4875* (2013.01); *A61B 5/04007* (2013.01); *A61B 5/0022* (2013.01); *A61B 5/6803* (2013.01); *A61B 5/04525* (2013.01); *A61B 5/031* (2013.01); *A61B 2562/0223* (2013.01); *A61B 2560/0223* (2013.01)

(57) **ABSTRACT**

A device for detecting spatial differences in fluid level changes in a tissue of a patient may include a support structure for securing the device to a body part of the patient, a processing element operably connected to the support structure, a wireless networking interface operably connected to the support structure and in communication with the processing element and an external computing device via a network, a first transmission module operably connected to the support structure and in communication with the processing element, a second transmission module and a third transmission module operably connected to the support structure and in communication with the processing element. When activated, the first transmission module transmits a first time varying magnetic field through the tissue of the patient. The second and third transmission modules, which are spatially separated from one another, receive first and second versions, respectively, of the first time varying magnetic field.

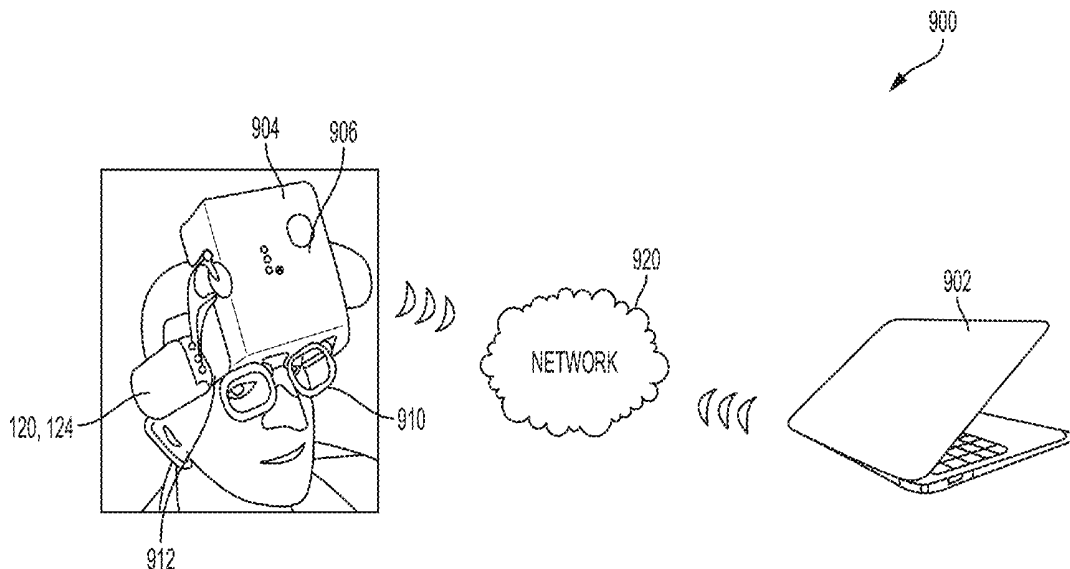

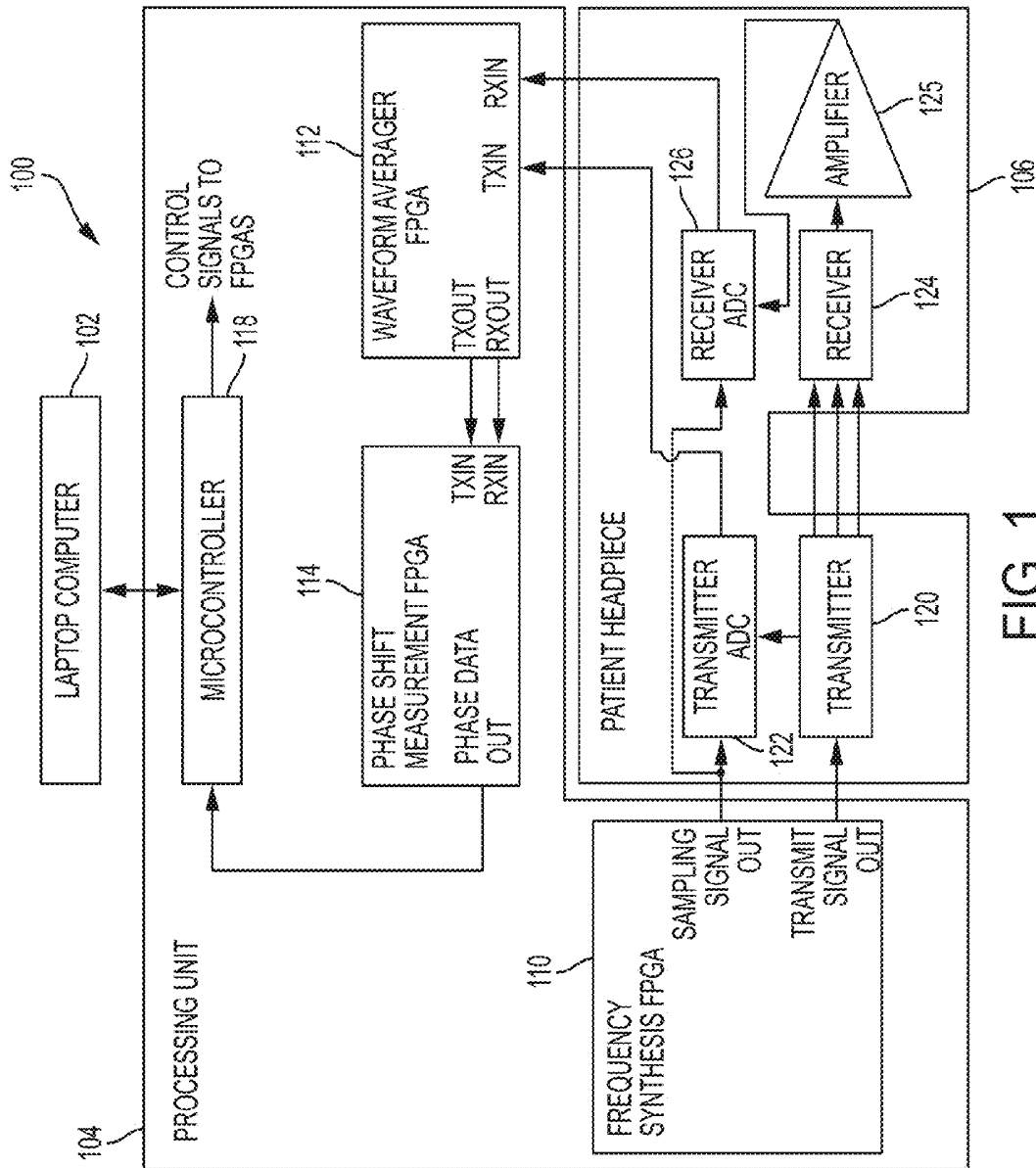

FIG. 1

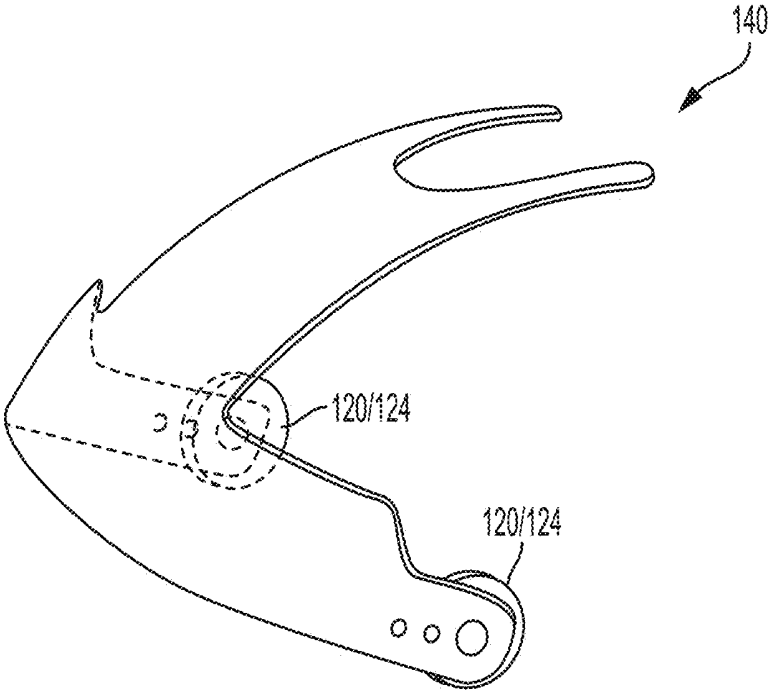

FIG. 1A

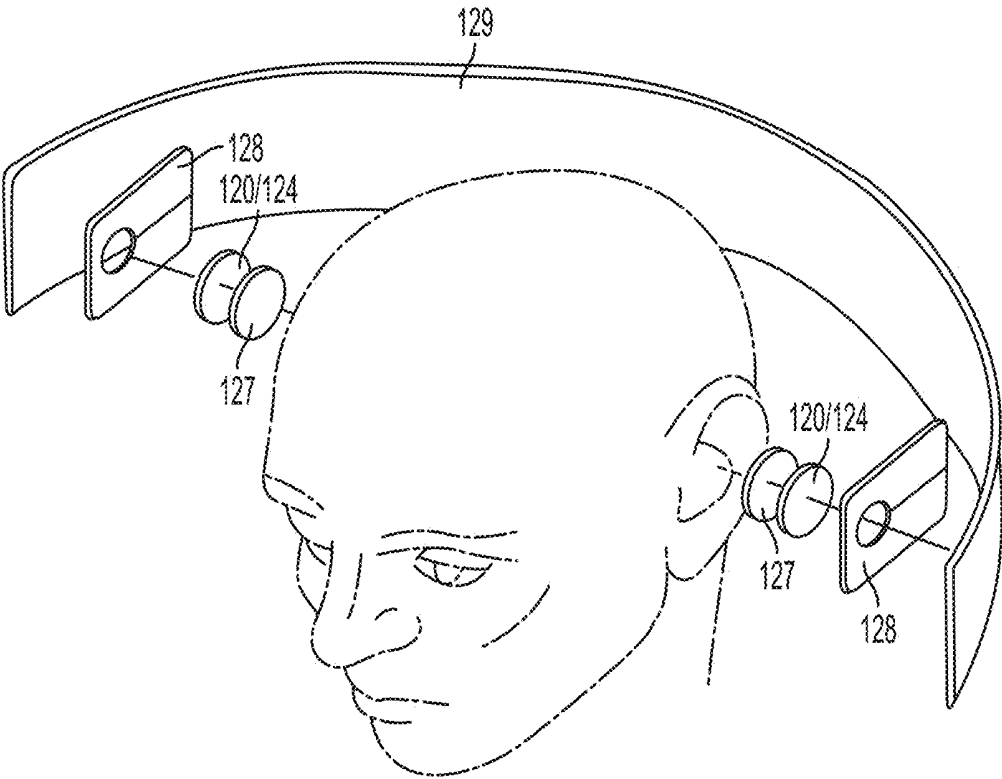

FIG. 1B

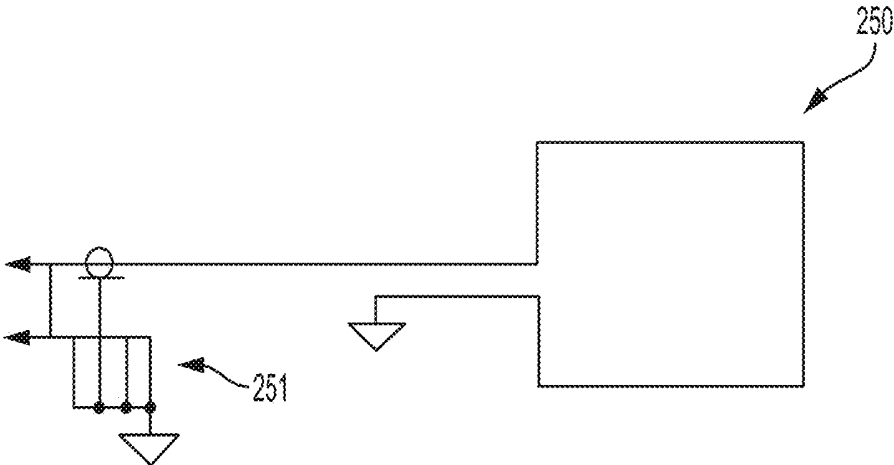

FIG. 2A

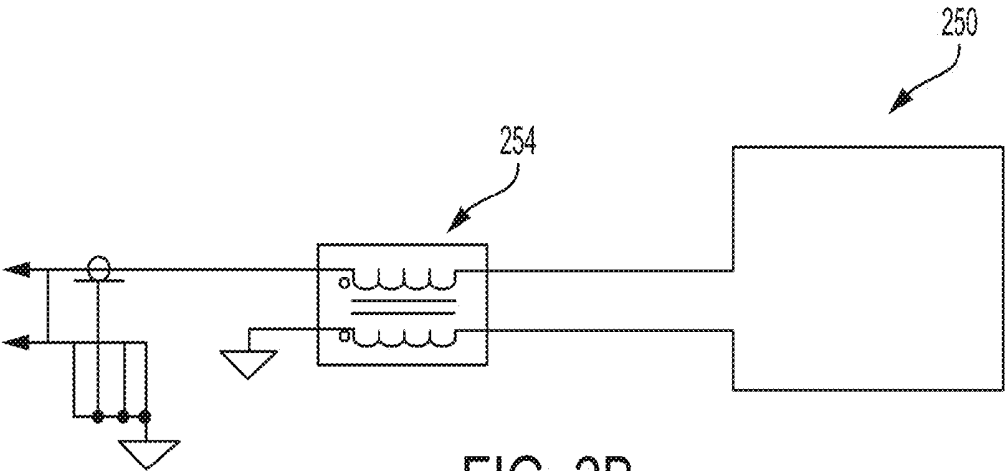

FIG. 2B

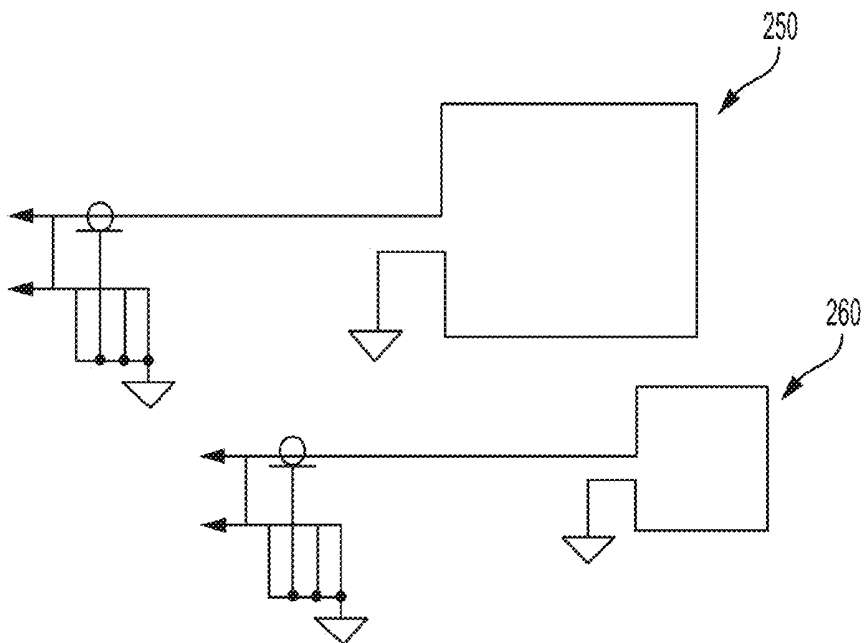

FIG. 2C

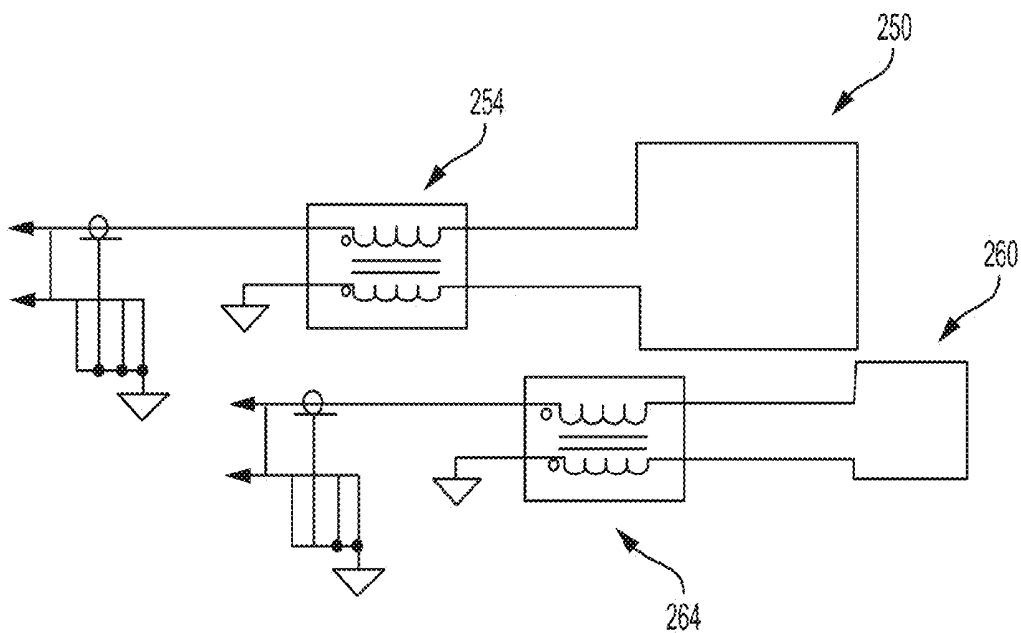

FIG. 2D

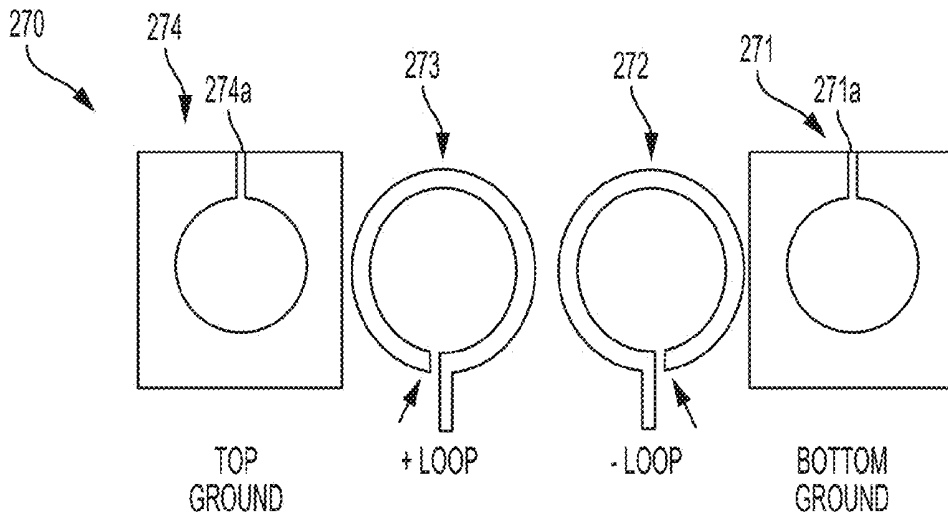

FIG. 2E

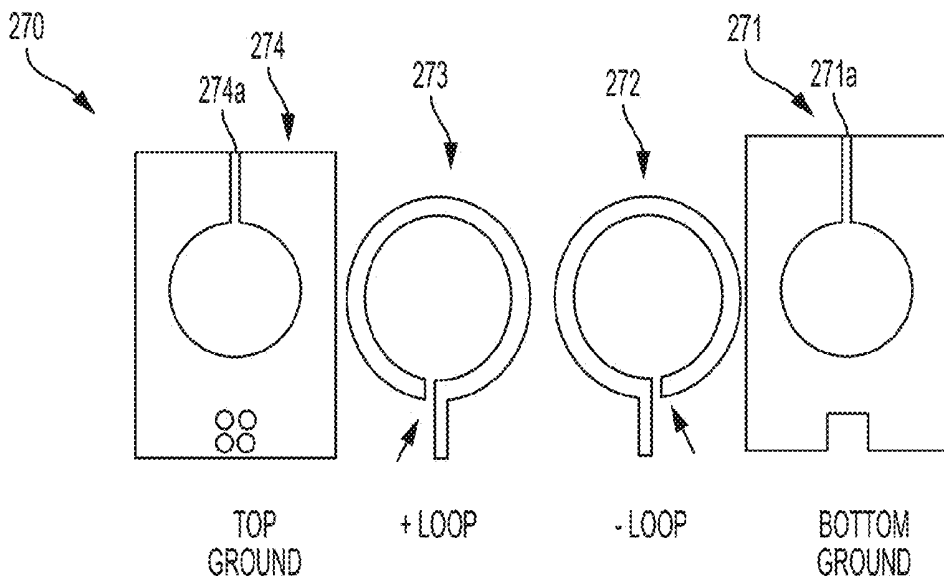

FIG. 2F

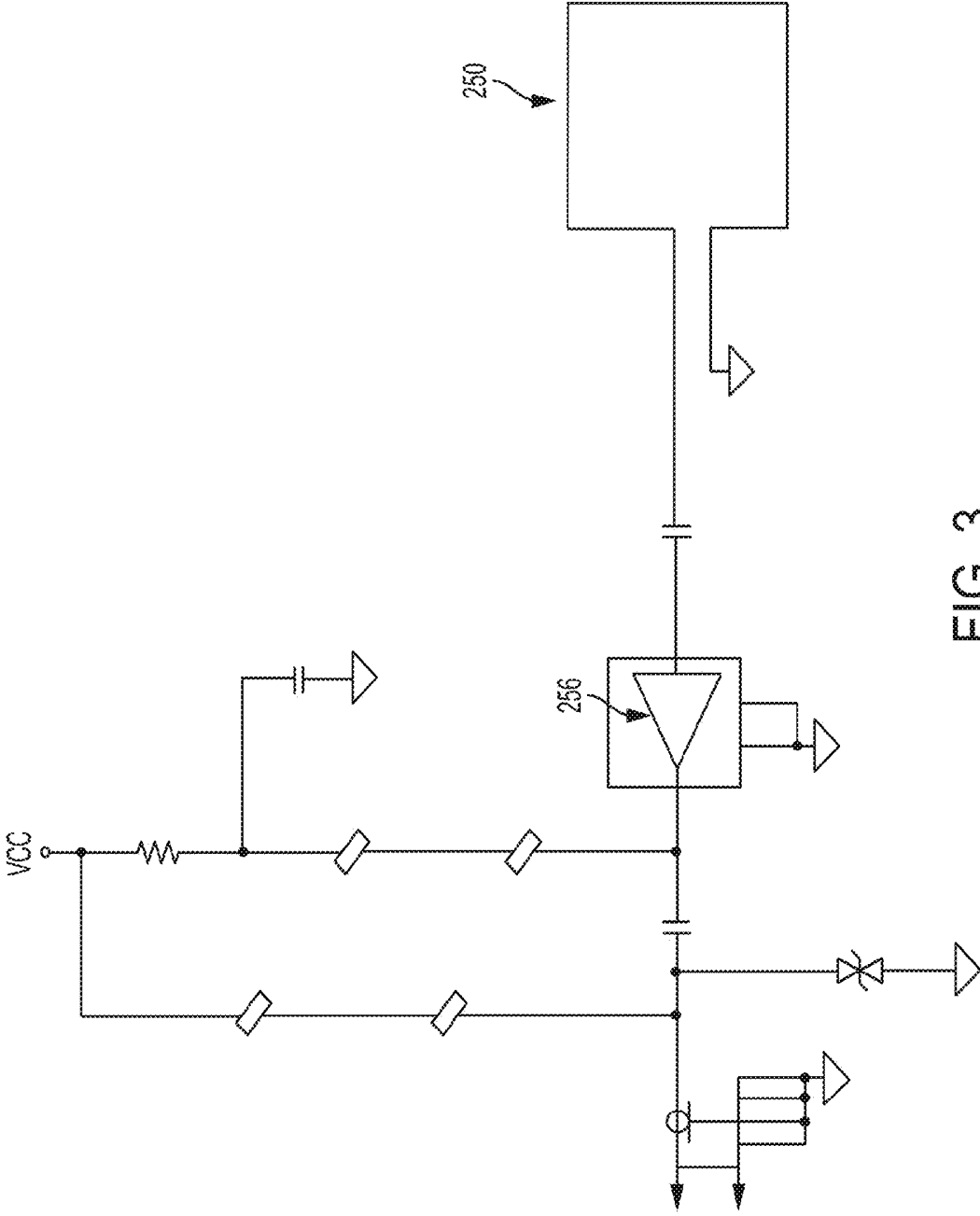

FIG. 3

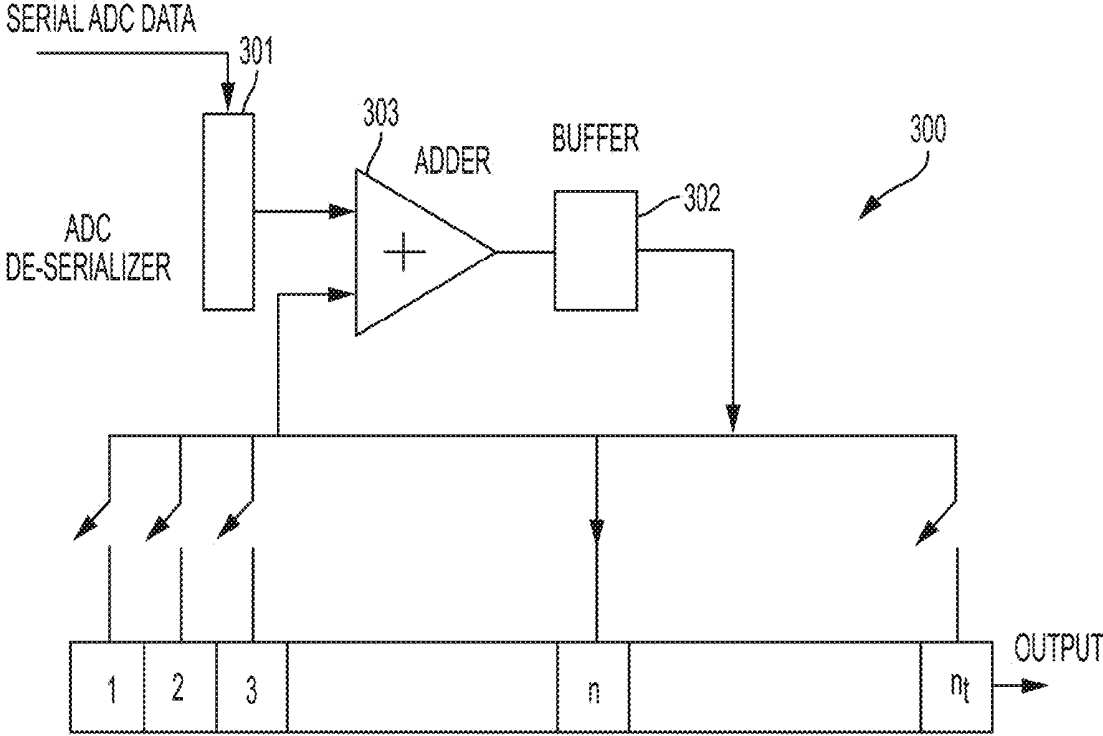

FIG. 4

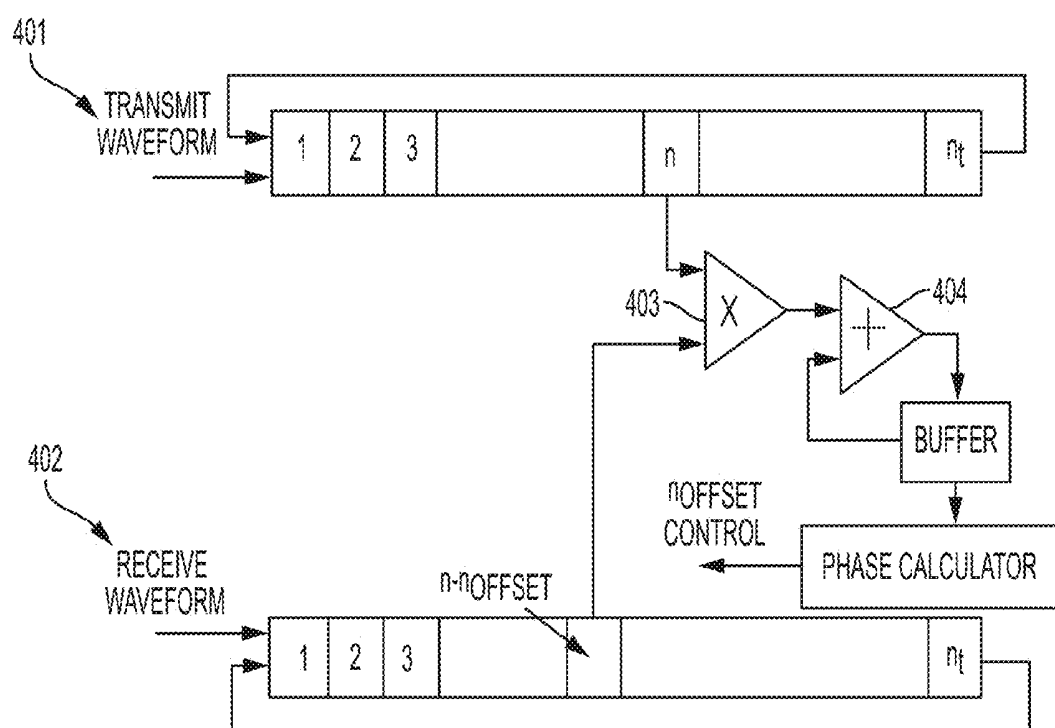

FIG. 5

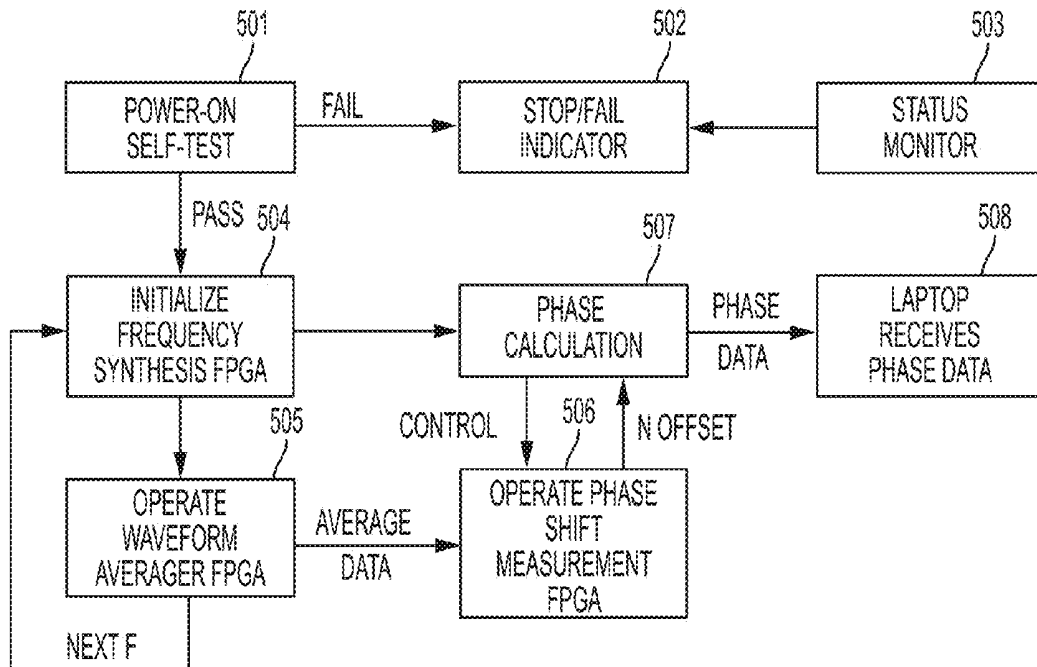

FIG. 6

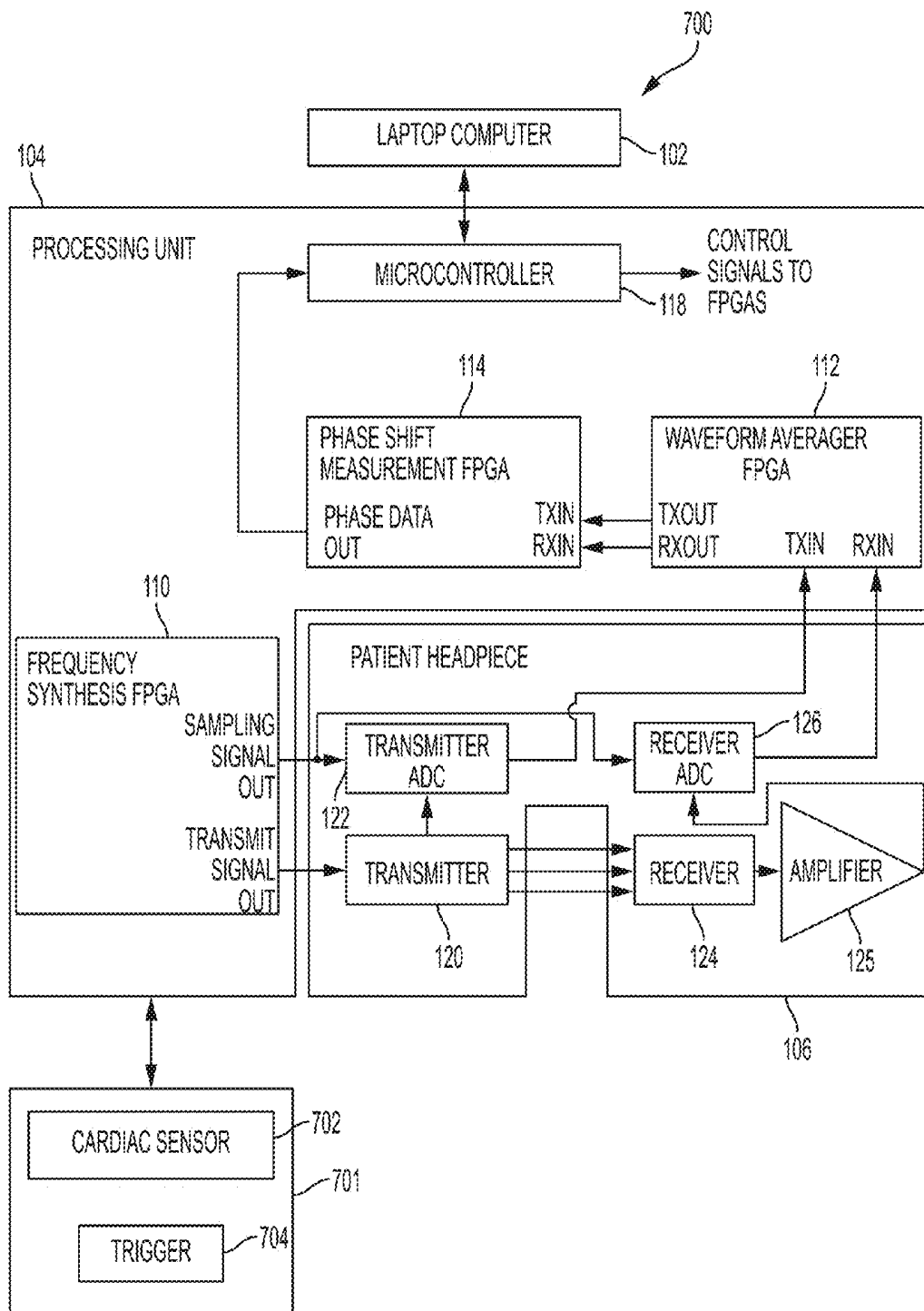

FIG. 7

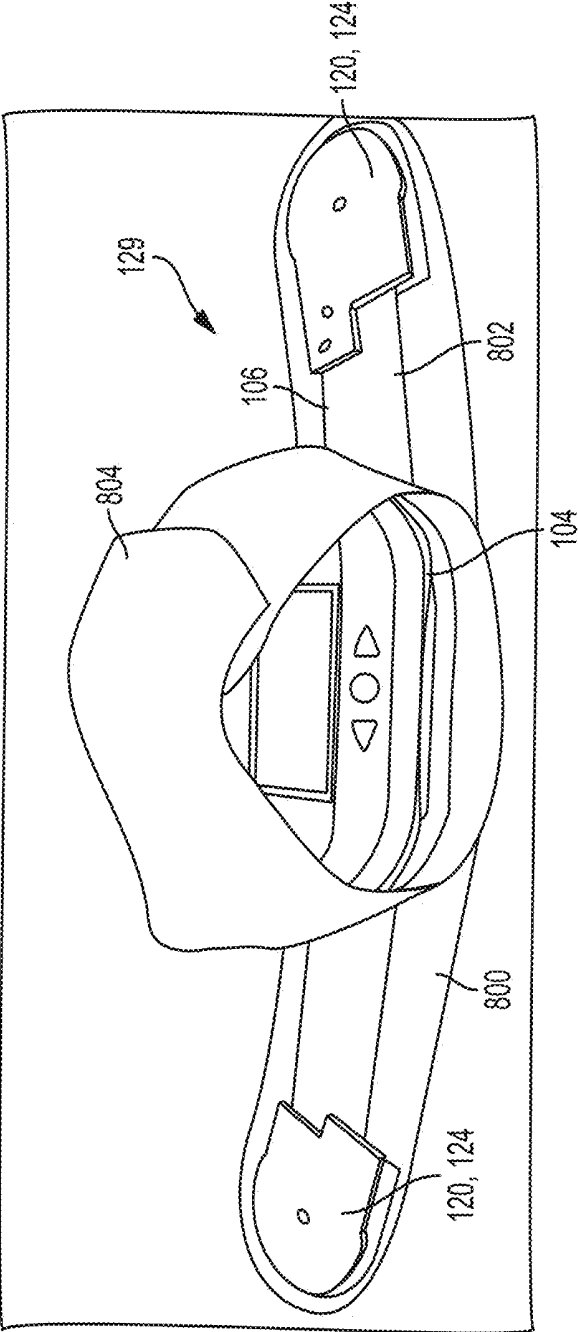

FIG. 8

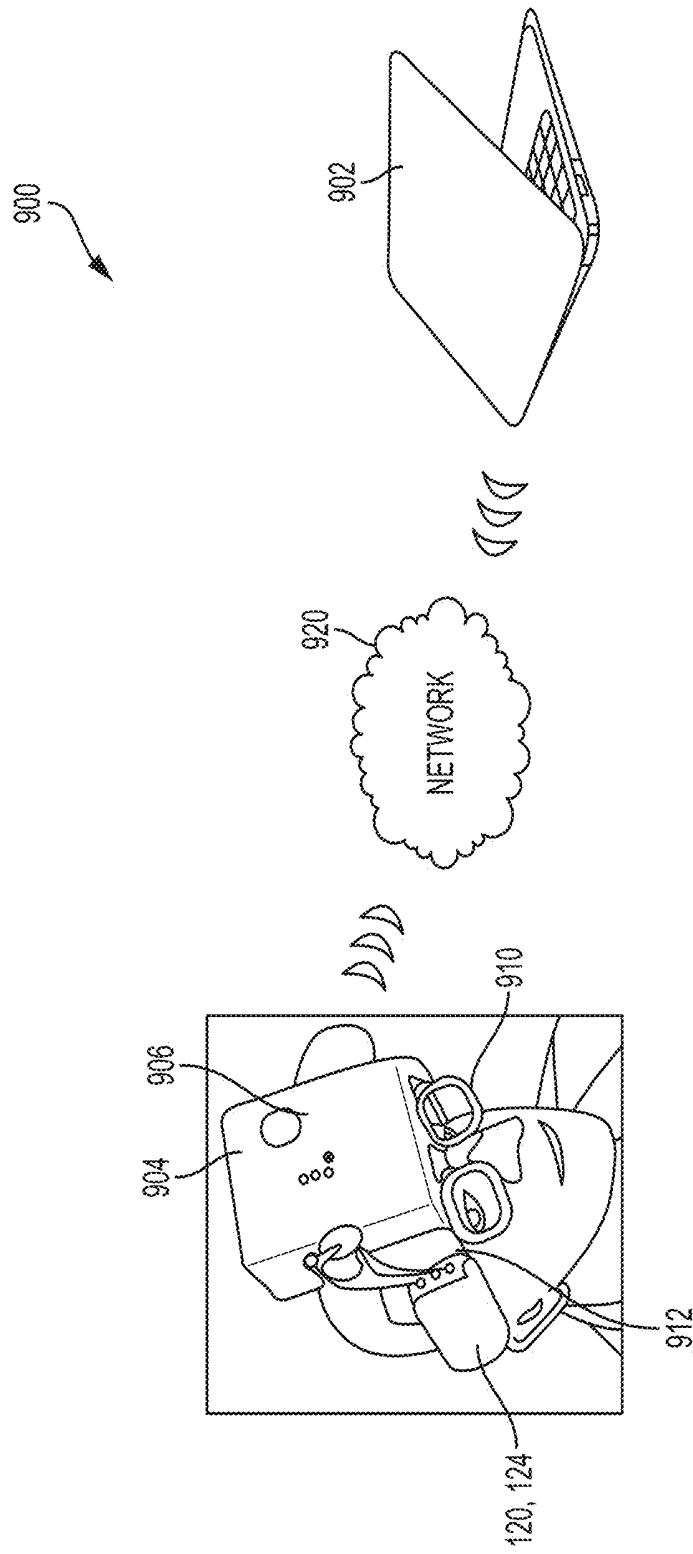

FIG. 9

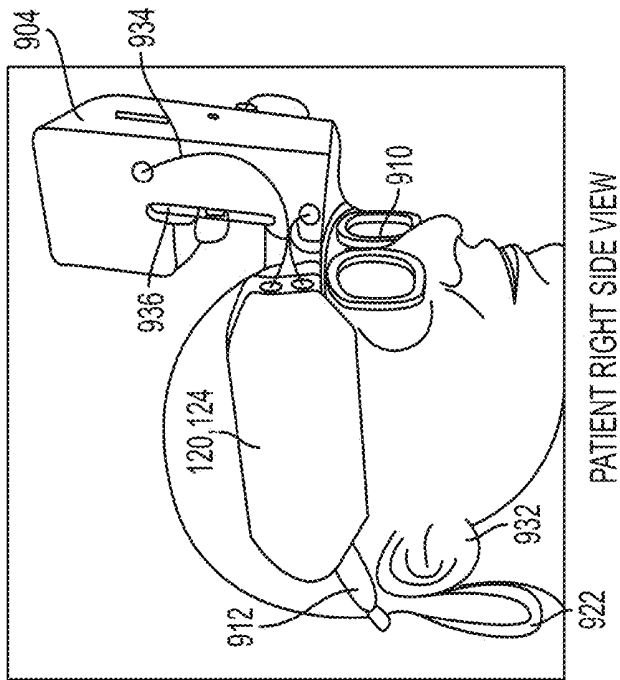
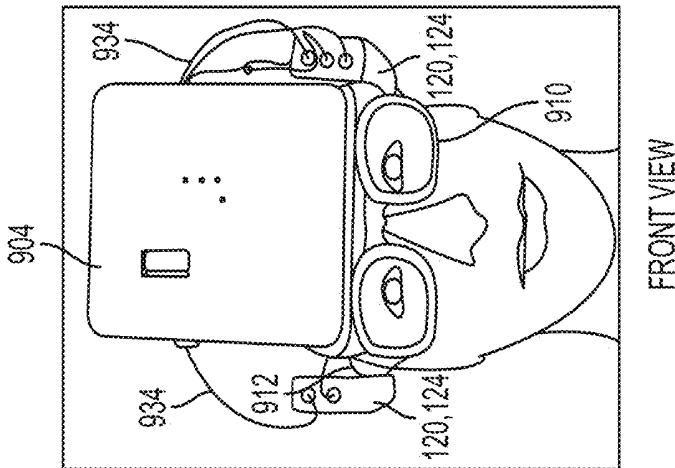
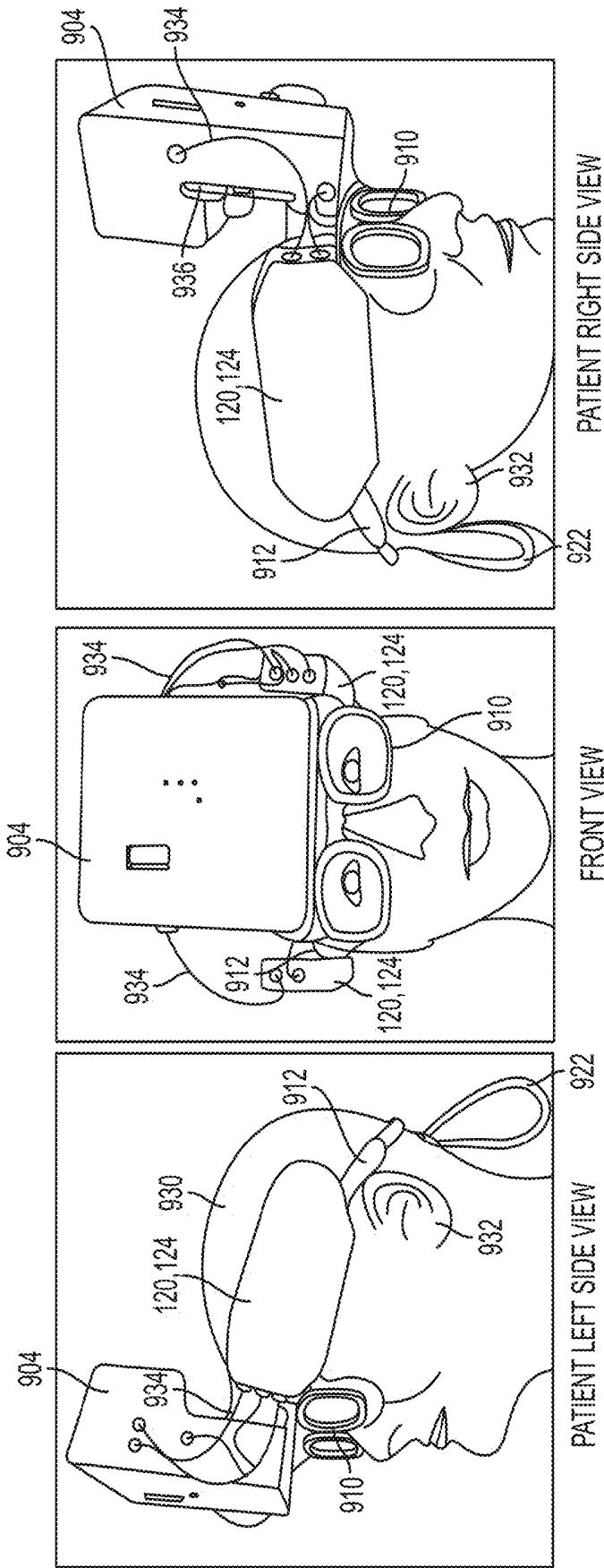

FIG. 10A

FIG. 10B

FIG. 10C

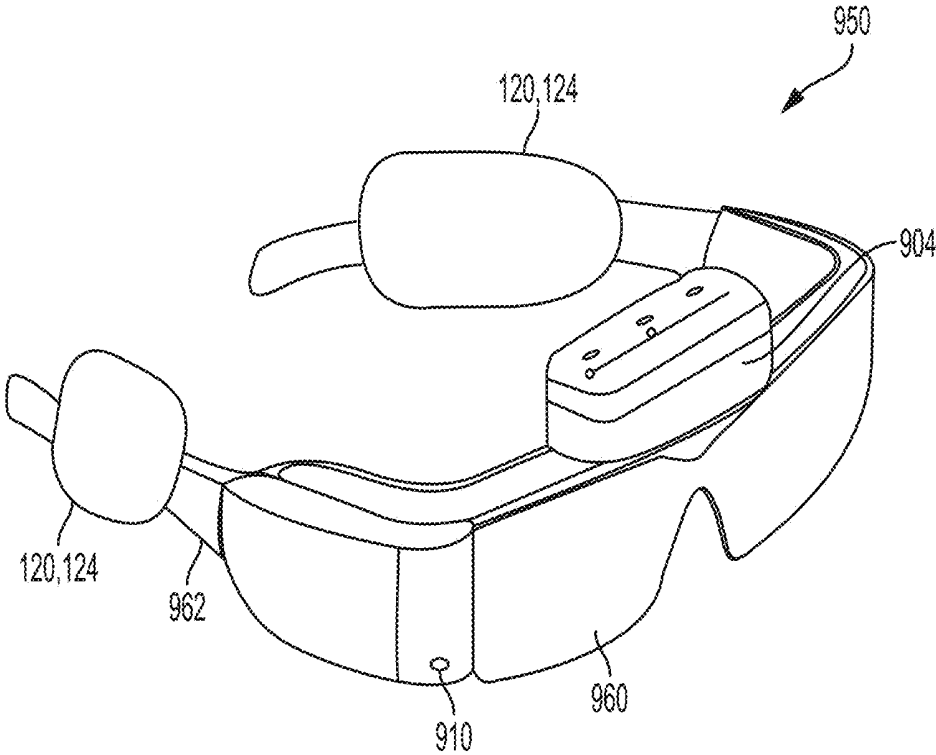

FIG. 11

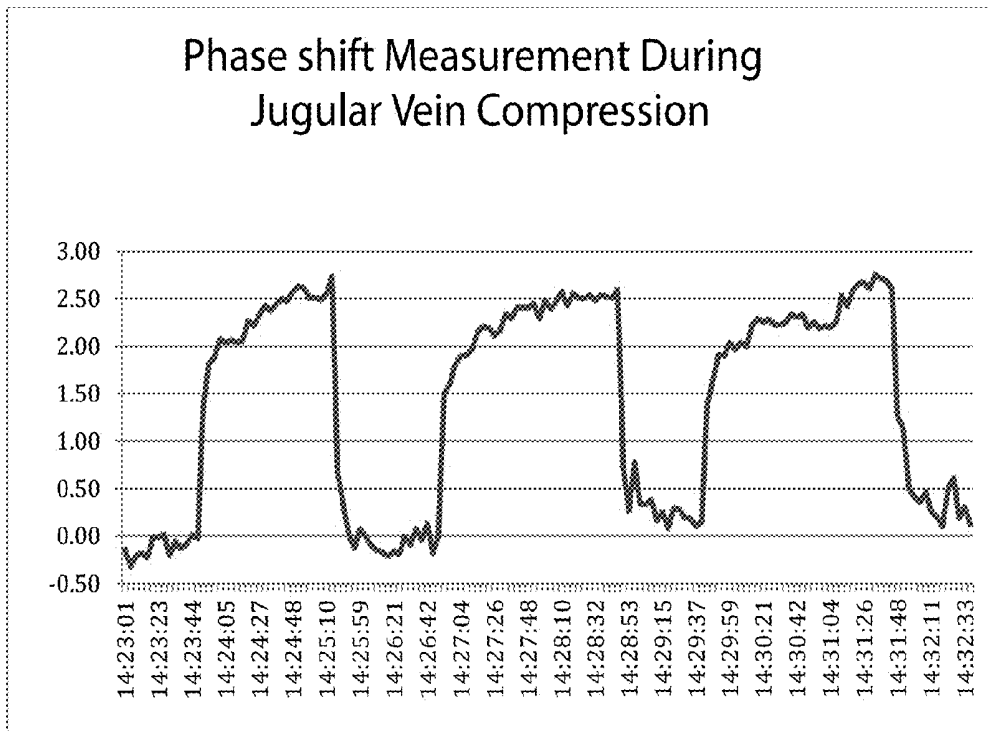

FIG. 12

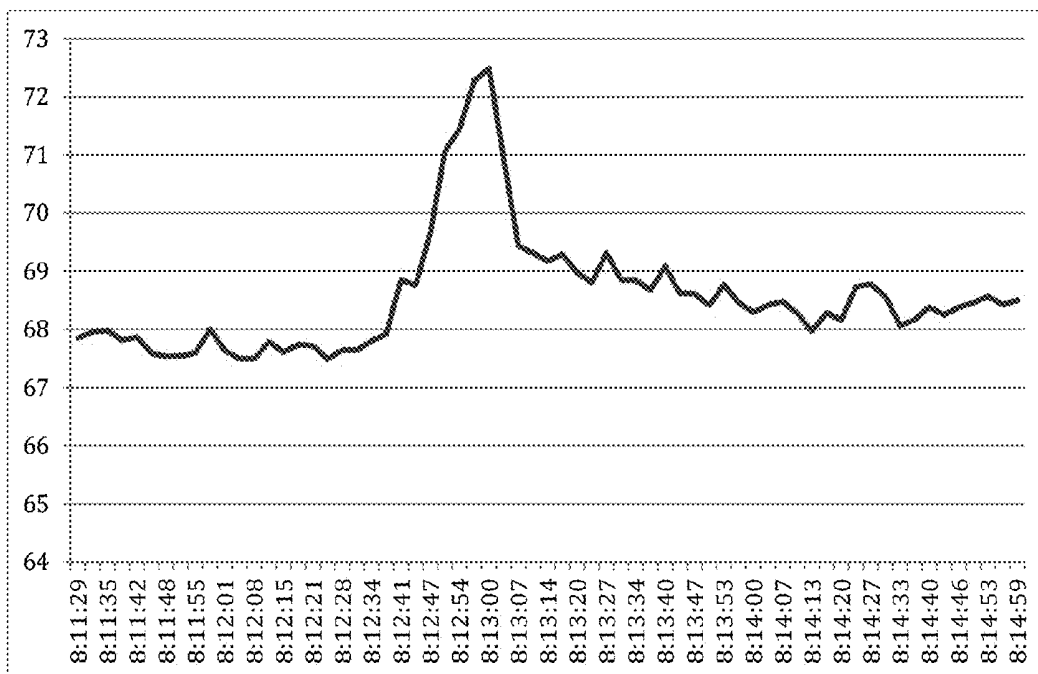

FIG. 13

DETECTION AND ANALYSIS OF SPATIALLY VARYING FLUID LEVELS USING MAGNETIC SIGNALS

CROSS-REFERENCE TO RELATED APPLICATIONS

[0001] This application is a continuation-in-part of U.S. non-provisional patent application Ser. No. 14/690,985, entitled "Method for Detecting and Treating Variations in Fluid," filed Apr. 20, 2015, which is a continuation of U.S. non-provisional patent application Ser. No. 14/275,549, entitled "Method for Detecting and Treating Variations of Fluid," filed May 12, 2014, which is a continuation of U.S. non-provisional patent application Ser. No. 13/745,710, entitled "Diagnostic method for detection of fluid changes using shielded transmission lines as transmitters or receivers," filed Jan. 18, 2013, and issued as U.S. Pat. No. 8,731,636 on May 20, 2014, which claims benefit of U.S. provisional patent application Ser. No. 61/588,516, entitled "Diagnostic Device for Detection of Fluid Changes in the Brain and Other Areas of the Body," filed Jan. 19, 2012.

[0002] This application also claims priority to U.S. provisional patent application Ser. No. 62/131,882, entitled "System and Methods for Detection of Tissue Fluid Changes," filed on Mar. 12, 2015; 62/048,690, entitled "Characterization of the Health Status of Tissue Through the Signature of an Electromagnetic Signal in Response to Voluntarily Induced Changes in Tissue Condition," filed Sep. 10, 2014; and 62/045,044, entitled "System and Methods for Detection of Tissue Fluid Changes," filed on Sep. 3, 2014.

[0003] This application is also related to U.S. provisional patent application Ser. No. 62/011,809, entitled "System and Methods for Detection of Tissue Fluid Changes," filed on Jun. 13, 2014; and 61/939,678, entitled "System and Methods for Detection of Tissue Fluid Changes," filed on Feb. 13, 2014. The full disclosures of the above-listed patent applications are hereby incorporated by reference herein in their entireties.

TECHNICAL FIELD

[0004] This application is related to noninvasive, diagnostic, medical devices, systems and methods. More specifically, some embodiments of this disclosure relate to devices, systems and methods that use volumetric integral phase-shift spectroscopy ("VIPS") to monitor changes in fluids in the brain or other parts of the body. (VIPS may alternatively be referred to by other acronyms, such as magnetic induction phase-shift spectroscopy ("MIPS")).

BACKGROUND

[0005] In many different medical settings, it would be advantageous to be able to detect changes in bodily fluid composition and distribution as they occur, in a noninvasive manner. For example, it is often critical to monitor changes in intracranial fluid content or distribution in an intensive care unit patient. Standard of care for these patients includes invasive monitors that require drilling a hole in the cranium and inserting a probe, such as an intracranial pressure (ICP) monitor, or microdialysis or "licox" probes, for measuring chemical changes to the fluids in the brain. No continuous, noninvasive measurement techniques are currently commercially available for detecting cerebral fluid changes, such as those that occur with bleeding or edema. Furthermore, many brain injuries are not severe enough to warrant drilling a hole in the

cranium for invasive monitoring. Thus, for many patients with brain injury, there is no continuous monitoring technology available to alert clinical staff when there is a potentially harmful increase in edema or bleeding. Instead, these patients are typically observed by nursing staff, employing a clinical neurological examination, and it is not until changes in the fluid composition or distribution in the brain cause observable brain function impairment that the physicians or nurses can react. In other words, there is no way currently available for monitoring intracranial fluid changes themselves, and thus the ability to compensate for such changes is limited.

[0006] VIPS has been previously proposed for diagnosis of brain fluid abnormalities. Patents have been awarded for proposed devices, and promising scientific studies of prototype devices are described in the literature. For example, Rubinsky et al. described the use of VIPS for this purpose, in U.S. Pat. Nos. 7,638,341, 7,910,374 and 8,101,421, the disclosures of which are hereby incorporated in their entirety herein (referred to herein as the "Rubinsky Patents"). Wyeth et al. described additional details of the use and design of VIPS devices in U.S. Pat. No. 8,731,636, which is hereby incorporated in its entirety herein. However, no practical, mass-produced medical device based on VIPS technology has yet emerged, to provide clinicians specializing in brain treatment or other areas of medicine the promised benefits of such a device.

[0007] Ideally, a medical device solution would provide a VIPS system with improved performance, usability and manufacturability, such that it could be used for noninvasive fluid change detection in the brain and/or other areas of the body. The embodiments described herein endeavor to address at least some of these objectives.

BRIEF SUMMARY

[0008] In one embodiment, the present disclosure includes a device for detecting spatial differences in fluid level changes in a tissue of a patient. The device includes a support structure for securing the device to a body part of a patient, a processing element operably connected to the support structure, a wireless networking interface operably connected to the support structure and in communication with the processing element and an external computing device via a wireless network. The device also includes first, second, and third transmission modules, each of the modules are connected to the support structure and are in communication with the processing element. The second and third transmission modules are spatially separated from one another relative to the tissue of the patient, and the first transmission module is opposed to the second and third transmission modules, so as to transmit signals from the modules as they are transmitted through the tissue. When activated, the first transmission module transmits a first time varying magnetic field through the tissue of the patient, and the second and third transmission modules receive first and second versions, respectively, of the first magnetic field and transmit a first received magnetic field data corresponding to the first and second versions to the processing element. The processing element provides transmission data corresponding to the first received magnetic field data to the wireless networking interface, which in turn transmits the transmission data wirelessly to the external computing device. In another implementation, the first transmission module may be configured to receive first and second time varying fields transmitted by the second and third transmission modules, respectively.

[0009] In yet another embodiment, the present disclosure includes a method for detecting symmetry in fluid levels in a tissue of a patient. The method includes securing a device, including a receiver, a first transmitter, and a second transmitter on the patient's head, such that the first transmitter and the second transmitter are spatially separated from one another and the receiver is positioned to be in communication with the first transmitter and the second transmitter via a transmission pathway through the tissue. The method further includes transmitting a first time varying magnetic field from the first transmitter, transmitting a second time varying magnetic field from the second transmitter, receiving a first received field and a second received with the receiver, analyzing at least one transmission characteristic with a processing element, determining with the processing element that the first received field corresponding to the first time varying magnetic field and the second received field corresponds to the second time varying magnetic field, determining with the processing element a first phase shift between the first time varying magnetic field and the first received field, determining with the processing element a second phase shift between the second time varying magnetic field and the second received field and determining with the processing element a change in fluid in the tissue over a period of time based on the determined first and second phase shifts.

[0010] In yet another embodiment, the present disclosure includes a method for detecting variations in fluid levels in a patient. The method includes attaching a headset to the patient, the headset including a support band for securing the headset to a head of the patient, a processing element coupled to the support band and configured to transfer data wirelessly to an external computer, and multiple transmitter receiver components operably connected to the support band at discrete locations. The method further includes activating the headset to take one or more fluid level readings within the head of the patient, wirelessly transmitting the fluid data corresponding to the one or more fluid level readings from the processing element to the external computer, and analyzing the fluid data with the external computer.

BRIEF DESCRIPTION OF THE DRAWINGS

[0011] FIG. 1 is a block diagram of a system for monitoring fluid changes in the body, according to one embodiment;

[0012] FIG. 1A is a perspective view of a patient headpiece for use in the system of FIG. 1, according to one embodiment;

[0013] FIG. 1B is a perspective exploded view of another patient headpiece for use in the system of FIG. 1, according to one embodiment;

[0014] FIGS. 2A through 2F illustrate various embodiments of transmitter transducers and receiver sensors for use in the system of FIG. 1;

[0015] FIG. 3 is a circuit diagram of a phase shift detection apparatus, according to one embodiment;

[0016] FIG. 4 is a simplified logic diagram for a waveform averager processor for use in the system of FIG. 1, according to one embodiment;

[0017] FIG. 5 is a simplified logic diagram of a phase shift measurement processor for use in the system of FIG. 1, according to one embodiment;

[0018] FIG. 6 is a flow diagram for the operation of the system of FIG. 1, according to one embodiment;

[0019] FIG. 7 is a block diagram of a system for monitoring fluid changes in a body corresponding to a cardiac signal;

[0020] FIG. 8 is an isometric view of an embodiment of a system for monitoring fluid changes including a temporary stabilizer;

[0021] FIG. 9 is a system diagram for another example of a system for monitoring fluid changes in a body;

[0022] FIG. 10A is a left isometric view of a patient wearing the headpiece of the system of FIG. 9;

[0023] FIG. 10B is a front elevation view of the patient wearing the headpiece of FIG. 10A;

[0024] FIG. 10C is a right isometric view of a patient wearing the headpiece of FIG. 10A; and

[0025] FIG. 11 is a front isometric view of another example of a system for monitoring fluid changes in a body.

[0026] FIG. 12 is a graph illustrating calibrated phase shift measurements as a function of time.

[0027] FIG. 13 is a graph illustrating changes in phase shift reading as a function of time during the Valsalva procedure.

DETAILED DESCRIPTION

[0028] Certain details are set forth below to provide a sufficient understanding of certain embodiments of the present disclosure. However, some embodiments of the disclosure may be practiced without these particular details. Moreover, the particular embodiments of the present disclosure are provided by way of example and should not be used to limit the scope of this disclosure to those particular embodiments. In some instances, well-known circuits, control signals, timing protocols, and software operations have not been shown in detail, in order to avoid unnecessarily complicating the description.

Overall System Architecture

[0029] FIG. 1 is a block diagram of one embodiment of a system **100** that may be used to detect fluid changes in a human brain. Although this description often focuses on use of the system **100** for detecting fluid changes in the brain, this embodiment of the system **100** or alternative embodiments may be used for detecting/monitoring fluid changes in any other part of the body. Therefore, the exemplary description provided herein that is directed toward the brain should not be interpreted as limiting the scope of the invention as it is set forth in the claims.

[0030] The system **100** may include a laptop computer **102** or other computing device, a processing unit **104**, and a patient headpiece **106** in some examples. The system **100** may be controlled, for example, by a windows-based labview language program running on the laptop computer **102**. The program generates a graphical user interface (GUI) that is displayed on the screen of the laptop **102**. The clinician who operates the system **100** may initiate monitoring by mouse control after placing the headpiece **106** on the patient, which may be similar to an elastic headband or bandage. After initiation of monitoring, the program may run unattended as it logs the phase shift data on the laptop **102** and applies the appropriate methods to generate alarms and suggested corrective actions to a clinician.

[0031] The laptop **10**, which may be an external computer relative to the patient headpiece **106**, may have a USB serial link to the processing unit **104**. This USB link may be electrically isolated to conform to applicable medical device requirements. The processing unit **104** may derive power from a standard universal AC line power connection consistent with international standards. There may be a medical

grade low-voltage DC power supply to power all of the processing unit's **104** internal electronics that meets applicable standards for patient isolation, line to neutral, chassis, and patient leakage as well as earth to ground continuity, EMI susceptibility and emissions, and other standard medical device requirements.

[0032] The laptop **102** may initiate phase shift data collection and log the data in files on the laptop's **102** hard drive along with other pertinent data and status information.

[0033] The GUI on the laptop **102** may control the operation of the system **100**, and may include controls and status indications that guide the clinician through installation of the patient headpiece **106** and a preliminary self-test of the entire system **100**. If the self-test passes, the clinician is instructed to initiate monitoring. During monitoring, the phase shift angle versus frequency data is collected from the USB interface and appropriate status and alert methods are applied to the data. The clinician may be informed if additional actions or emergency responses are indicated. The phase shift versus frequency data and additional status information is logged in the laptop **102** for later reference. A "sanity check" of the data and other built-in-test features may run continuously in the background, and if a fault is encountered, various levels of severity will generate warnings or interrupt operation of the system **100**.

[0034] The architecture of hardware and firmware in the processing unit **104** and the patient headpiece **106** may be optimized to achieve the desired phase measurement accuracy and stability while using a minimum number of custom electronics components in some examples and as illustrated in FIG. 1. For example, in one embodiment, and with reference to FIG. 1, the system **100** may comprise several highly integrated miniaturized off-the-shelf components. The system **100** may include three field programmable gate arrays (FPGAs) **110**, **112**, **114** in the processing unit **104**, the three FPGAs being programmed with appropriate firmware. One FPGA **110** may synthesize a time-varying signal to be provided to a transmitter (transmitter may be alternatively be referred to by emitter) **120** to generate a magnetic field, the second FPGA **112** may collect and average digital samples of transmitted and received magnetic fields, and the third FPGA **114** may measure the phase shift between the transmitted and received signals representative of the transmitted and received magnetic fields.

[0035] A microcontroller **118** may also be included in the processing unit **104**, and may supervise the actions of the three FPGAs **110**, **112**, **114** and communicate with the laptop **102** (e.g., by transferring phase data results). The microcontroller **118** may provide an interface between the external laptop computer **102** (via an electrically isolated USB interface) and the FPGAs **110**, **112**, **114** used for real time signal processing of the data from the headpiece **106**. The microcontroller **118** may also perform other miscellaneous functions such as the interface to basic user controls including power-on, initiation of data collection, setup of the frequency synthesizer **110**, internal temperature monitoring, power supply monitoring, and other system status monitoring and fault detection tasks.

[0036] The processing unit **104** may in some examples be fabricated from larger, integrated components. In one embodiment, the processing unit **104** may include an off-the-shelf electronic signal generator, such as a Techtronix Arbitrary Waveform Generator model 3252, and a digital oscillo-

scope such as LeCroy Model 44xi. Conversely, processing unit **104** could be integrated into a single ARM processor.

[0037] The architecture of the system **100** illustrated in FIG. 1 may be relatively flexible, allowing improvements in all phases of the data collection, data processing, and data interpretation (e.g., clinical alerts) to be made through relatively simple software or firmware modifications. The FPGAs **110**, **112**, **114** may effectively function as parallel processors to make data collection and processing proceed in near real time. The quantity of phase data transmitted via the microcontroller **118** to the laptop **102** and archived for later reference may thus be reduced, thereby requiring less computation time on the laptop **102** for processing the data. This may in turn free up the laptop **102** for checking data consistency and applying methods required for alerting clinicians to the need for corrective actions.

[0038] Although the processing unit **104** in FIG. 1 has been illustrated and described as a relatively flexible embodiment, in other examples the diagnostic system **100** may be an embedded system with custom electronics components specially designed for use in the diagnostic system **100**. For example, one or more analog to digital (A to D) converters may be located in the processing unit **104**, which may be physically distinct and separate from the headpiece **106**, or which may be integral with the headpiece **106** (e.g., the headpiece **106** may, in a custom system **100**, include all of the electronics and processing equipment needed to capture and process phase shift information). Also, the functions executed by the three FPGAs may be combined into one FPGA. In general, any suitable architecture may be used.

[0039] Referring again back to FIG. 1, the system **100** may also include a headpiece **106** with transmission modules, such as one or more transmitters **120** and one or more receivers **124**, the details of which are explained in more detail below. In one example, the headpiece **106** includes a single transmitter **120** and a single receiver **124**, whereas in other examples, the headpiece **106** includes several transmitters **120** and/or several receivers **124**. For example, the headpiece **106** may include one transmitter **120** and two receivers **124**. If multiple receivers **124** are placed at different positions over a patient's head, they may allow a clinician to triangulate the location of a fluid change (e.g., intracerebral bleeding from a blood vessel or tumor) and/or image the biological impedance of a patient's brain. In other examples, the headpiece **106** may include multiple transmitters **120**, which may produce magnetic fields at different or similar frequencies. If different frequencies are used, a single or multiple receivers **124** may be able to distinguish among the several transmitted frequencies in order to, for example, further distinguish the type of fluid change. As discussed in more detail below, other types of transmission characteristics, such as variations in time transmission, wave shape, frequency, attenuation, amplitude, and/or additional waves may be used to identify a particular transmitter for a particular signal.

[0040] In some examples, in addition to the receiver **124** positioned elsewhere on the patient's head, an additional receiver may be positioned on the same side of the patient's head as the transmitter **120** (e.g., the receiver may be concentric within or may circumscribe the transmitter **120**, or may be positioned in a separate plane from the transmitter **120**) in order to obtain a measurement of the transmitted magnetic field from the transmitter (not shown in FIG. 1). In other examples, the emitted magnetic field may be sampled from the transmitter **120** in another fashion, such as by measuring

the current and/or voltage present on the transmitter 120. In some examples, and with reference to FIG. 1, the patient headpiece 106 includes A to D converters 122, 126 for one or more of the transmitter(s) 120 and/or receiver(s) 124 proximate the respective transmitter(s) 120 and/or receiver(s) 124 themselves—for example, A to D converters may be positioned on the same printed circuit board as the respective transmitters 120 or receivers 124 in some examples.

[0041] In other examples, however, the analog signals are not converted into digital signals until after being passed through one or more coaxial cables (or other transmission lines) connected to a separate processing unit (e.g., the processing unit 104 shown in FIG. 1). In these examples, various techniques may be employed to reduce cross-coupling between, for example, a coaxial cable carrying a signal indicative of the transmitted magnetic field from the transmitter 120 and a coaxial cable carrying a signal indicative of the measured magnetic field from the receiver 124. For example, a relatively flexible RF-316 double shielded cable may be used to increase the isolation between the two cables, or, in other examples, triple shielded cables may be used. As another option, highly flexible PVC or silicone tubing may be provided around the coaxial cable from the receiver 124 and/or transmitter 120.

[0042] Referring again to the headpiece 106 illustrated in FIG. 1, for repeatable readings, it may be important for the transmitter 120 and receiver 124 to not move during operation of the system 100 because such movement may introduce an error in the phase shift measurement. In order to overcome such errors, the transmitter 120 and receiver 124 may be mounted in a rigid manner in some examples, for example in an apparatus that resembles a helmet 140, one example of which is illustrated as FIG. 1A. The helmet 140 may provide the necessary support and rigidity to ensure that the transmitter 120 and receiver 124 remain fixed relative to each other and relative to the patient's head. However, such a helmet 140 may be uncomfortable or impractical to use on a patient while they are lying down. Also, it may not be practical for a patient to wear the helmet 140 for several days as may be desirable in some clinical situations.

[0043] Accordingly, in an alternate embodiment, and with reference to FIG. 1B, the transmitter 120 and receiver 124 are held against the head of the patient using a headset 129, such as an elastic band 129. The transmitter 120 and receiver 124 may be mounted on the headset 129, for example, by securing them inside a pocket of the headset 129, or using stitches, rivets or other fasteners. The transmitter 120 and receiver 124 may be spaced at a fixed distance from the surface of the skin by incorporating a non-conductive spacer material 127, such as plastic or fabric. The spacers 127 can serve the purpose of maintaining a fixed distance between the transmitter 120 and receiver 124 from the skin in order to, for example, reduce variability of the capacitance between the transmitter 120/receiver 124 and the skin. The spacers 127 may be, for example plastic acrylic disks in some embodiments. Rubber, medical adhesive, or other material may also or alternatively be used for the spacers 127, and may be placed at the skin interface surface of the transmitter 120 and receiver 124 to aid in keeping them from moving during use.

[0044] The headset 129 may be placed on the patient's head across the forehead and around the back of the head in some embodiments; or a different band or other device can be placed in other configurations, including around a patient's chest, arm or leg. In other words, any suitable positioning

device may be used to appropriately position the transmitter 120 and receiver 124 proximate the area of the patient's body under investigation, of which the headsets 106, 129 and headbands 129 described herein are merely examples. Additional features such as a chin strap or a connection over the top of the head can be added to the headset 129 to provide additional stability and to provide features on which to mount additional transmitters 120 or receivers 124. Since the patient will often be lying on a pillow, a convenient location for electrical components and for cable terminations might be the top of the head. For example, a bridge from a point near each ear may be created so that the electronics can be mounted at the top of the head, away from the surfaces that the patient may lie on. Low-profile components that are lightweight may be used so as to maximize comfort and minimize the tendency of the headset to move on the patient's head once in place.

[0045] In the headset 129 design, a headband 129 may be made of elastic, rubber, acrylic, latex or other flexible material, and may be elastic or inelastic. The headset 129 may be fabricated from inexpensive materials so the headset can be a disposable component of the system. Alternatively, the headset 129 may be reusable. If it is reusable, the band 129 may be washable so that it can be cleaned between patients, or cleaned periodically for the same patient. Washable materials may include plastic, rubber, silicone, fabric, or other materials. The headpiece 106 may also include mounting means for securing the electronic components and to route the cables to keep them from getting in the way of the patient or the clinical staff.

[0046] In some embodiments, including those where a headband 129 is used, in order to reduce the relative motion between the transmitter 120/receiver 124 and the patient, one or more stabilizers 128 may be used. Stabilizers 128 may be custom-molded to the patient's body to hold the transmitter 120 and/or receiver 124 in place. As one example of a stabilizer 128, trained clinicians may install the transmitter 120/receiver 124 using low-melting-point plastic that is similar to orthopedic casts made from the same material. Other custom-shapeable materials and methods may be used, such as materials which polymerize over time, or with activation by heat or chemical reaction such as materials used for making orthopedic casts or splints.

[0047] With reference now to the exploded view of FIG. 1B, the operation of one embodiment of using a headset 129 will be described, although it will be understood that similar bands 129 may be used to monitor fluid change in other parts of the body, such as a bandage wrapped around a leg or an arm. Each transmitter 120/receiver 124 may first be coupled to a respective spacer 127 by, for example, a screw or other fastener such as glue. The transmitter 120 and respective spacer 127 may then be positioned on a patient's head, and the stabilizer 128 may be positioned around the transmitter 120/spacer 127 in order to stabilize the transmitter and help prevent movement. The stabilizer 128 may need to be soaked in water or otherwise prepared for application prior to positioning it around the transmitter 120/spacer 127. Once the stabilizer 128 secures the transmitter 120/spacer 127, another stabilizer 128 may similarly be used to stabilize the receiver 124 and spacer 127 in a similar manner. The stabilizers 128 may solidify or dry out to perform the stabilizing function. Then, a headset such as a headband 129 may be wrapped around the stabilizers 128 and transmitter 120/spacer 127 and the receiver 124/spacer 127. In some embodiments, however, no stabilizers may be used, and the headband 129 may instead be

used to directly position the receiver **124**/spacer **127** and the transmitter **120**/spacer **128** on the patient's head. In still other embodiments, and as mentioned above, the headband **129** may include pockets for the transmitter **120** and receiver **124**, with the headband **129** material itself acting as a spacer. Also, in some embodiments, the headband **129** may have non-slip material applied to an interior side of the headband **129** to help prevent slippage of the headband **129** on the patient's head.

[0048] Other examples of the headset **129** may be used as well. FIG. 8 illustrates an isometric view of an example of the headset **129**. In this embodiment, the headset **129** may be substantially similar to the headset **129** shown in FIG. 1B. However, in this example, a stabilizer **800** may be included with the headset **129**. Additionally, the headset **129** may include a flexible circuit **802** or other wiring mechanism that may extend between the processing unit **104** and the transmitters and receivers **120**, **124**. The headset **129** may also include a securing element **804** such as a headband, elastic, or the like, which may be flexed and/or stretched to secure the headset **129** around a patient's head.

[0049] The stabilizer **800** temporarily secures the headset **129** on a user's head (or other desired location), but may allow the headset **129** to be removed when monitoring is no longer desired. The stabilizer **800** may generally be a skin compatible adhesive. The stabilizer **800** may be two-sided adhesive where one side may be secured to the headset **129** (such as to the flexible circuit **802** or securing element **804**) and the other side may be secured to the patient's head. As another example, stabilizer **800** may be adhesive such as glue or another similar fluid or gel with adhesive properties. As a specific example, the stabilizer **800** may be hydrogel.

[0050] In embodiments including the stabilizer **800**, the stabilizer **800** stabilizes and locks the various components of the headset **129** onto a specific position on the patient's body. This helps to ensure accurate readings, as the electronics (e.g., transmitters and receivers) and circuit **802** may remain in substantially the same orientations and positions, even if the patient moves. Further, the stabilizer **800** may further help to prevent distortion of the electronics, as the flexible extensions of the transmitter and receiver (e.g., the flex circuit **802**) can be shaped so as to curve or wrap around one dimension of the patient's head (or other monitored area), but do not substantially flex or stretch in the other dimension. As one example, the lateral positions of the transmitter and receiver **120**, **124** (i.e., front to back) and the flexible circuit **802** may remain stable when pressed against the surface of a patient's head.

[0051] Various embodiments include mechanical mechanisms for determining correct placement, alignment, and attachment to a specific position on the patient's body. For example, the helmet **140** in FIG. 1A, the headband **129** in FIG. 1B, the headset **906** of FIG. 9, and the headset **950** of FIG. 11. These mechanisms help ensure accuracy and repeatability of the placements, which in turn helps to ensure the accuracy and precision of the readings. Further improvements for mechanical stability and repeatability could be enhanced with sensors to detect and monitor a point of contact or series of contacts to the patient's body. For example, sensors could be placed on arms **962** of headset **950** of FIG. 11 such that they detect when the arms **962** are in contact with a location where the scalp meets the ear of the patient. Additionally or alternatively, a sensor could be located to detect when the backside of the lenses **960** or top internal edge of the

frame is at the right location to the forehead. Furthermore, the sensor or sensors could monitor the continued optimal placement of the headset during a measurement sequence. If at any time the headset moves away from the desired position, a sensor or sensors would send a signal to processing unit **104**, which could in turn inform the user to correct the headset placement and/or identify the measured data as non-ideal due to placement. A non-exhaustive list of the types of sensors that could be used in these embodiments include impedance, capacitive, conductive, optical, thermal, and distance.

[0052] Another example of a system for detecting fluid levels in a body will now be discussed. FIG. 9 is a diagram of a system **900** for detecting fluid levels in a body. FIGS. 10A-10C illustrate various views of a patient wearing a headset **906** of the system **900**. With reference to FIGS. 9-10C, the system **900** may include a headset **906** or support structure, a processing unit **104** having a network/communication interface for communicating with one or more external devices, one or more transmitters/receivers **124**, **124**, and a computing device **902**. The computing device **902** may be in communication with the headset **906** and/or the processing unit **904** via a network **920**. The network **920** may be, for example, WiFi, Bluetooth, wireless, or the like, and in many embodiments may be wireless to allow data to be transmitted from the processing unit **904** and headset **906** to the computing device **902** without cables, or the like. In these embodiments, the computing device **902** may be external from the headset **906**, in that the computing device may be a standalone device that is in communication with the headset **906** via a wireless communication pathway. In other embodiments, the networking interface may be in communication via one or more wired pathways to the external computer and/or network.

[0053] The computing device **902** may be substantially similar to the computer **102** of FIG. 1. In some embodiments, the computing device **902** may be portable, to allow a treating physician to more easily transport the computing device **902** between different patients. However, in embodiments where portability may not be needed, the computing device **902** may be substantially any other type of computer, such as, but not limited to, a server, desktop computer, work station, or the like. It should be noted that the computing device **902**, the processing unit **904**, and/or headset **906** may include a networking interface component that provides a communication pathway to the network **920** from each respective device.

[0054] With reference to FIGS. 10A-10C, the headset **906** will now be discussed in more detail. The headset **906** in this example includes the processing unit **904** and the transmitters/receivers **120**, **124**. The integration of the processing unit **904** and transmitters/receivers **120**, **124** onto a signal device allows the sensing unit to be more portable, easier to position on a patient, and enhances the mobility of the patient while the patient is wearing the device. Additionally, as discussed in more detail above, in embodiments where the processing unit **904** may do a substantial portion of the processing of the data close to the transmitters/receivers **120**, **124**, the risk of errors is reduced and the signal to noise ratio may also be reduced.

[0055] In one embodiment, the headset **906** includes a front support structure or frame **910** that defines the front of the sensing device. The front support structure **910** may support the processing unit **904** and define a frame for two lenses, e.g., for the left and right eyes of the patient. In embodiments where lenses are not required, such as when the patient does not need to wear glasses or have other eye protection, the lenses may be omitted to provide clarity for a user. The front

support structure **910** may be varied as desired based on the size and structure of the processing unit **904**.

[0056] With continued reference to FIGS. 10A-10C, the headset **906** may also include two arms **912** that extend from each end of the front support structure **910**. The arms **912** are configured to wrap around a patient's head **930** and be supported above and/or on the patient's ears **912**. The arms **912** may include contoured portions that better fit a patient's head **930** and/or ears **912** and that may further assist in retaining the device in position on the patient's head **930**. The headset **906** may be adjustable and in some embodiments may include a securing strap **922** connected to the ends of each arm **912**. The securing strap **922** is configured to tighten around the head **930** of the patient and secure the headset **906** in position. For example, a fastener or other device may selectively adjust the length of the securing strap **922** and assist in securing it around the head **930**.

[0057] As discussed above, in this example the headset **906** is configured to be portable and the transmission modules, e.g., the transmitters/receivers **120**, **124**, are connected to the headset **906**. In one example, such as the one shown in FIGS. 10A-10C, the transmitters/receivers **120**, **124** may be connected to the arms **912** of the frame so that when the headset **906** is positioned on the patient's head **930**, the transmitters and receivers **120**, **124** will be positioned opposed to one another and oriented to receive and transmit signals through the user's head **930**. The transmitters and receivers are configured to be in communication with one another and positioned so as to transmit or receive, respectively, signals to the corresponding device.

[0058] The transmitters/receivers **120**, **124** or transmission modules may be in communication with and receive power from the processing unit **904**. For example, a plurality of connection wires **934** may extend from the processing unit **904** and electrically connect the transmitters/receivers **120**, **124** to the processing unit **904**. The connection wires **934** may transmit power from a power source, such as a battery received within the battery slot **936** on the processing unit **904**, along with data and/or signals from the processing unit **904**. Additionally, the transmitters and receivers **120**, **124** may transmit data to the processing unit **904**, which may then transmit the data to the computing device **902**. For example, the receivers **124** may transmit the received signals to the processing unit **904**, which may then process the signals and transmit the data to the computing device **902** via the network **920**.

[0059] It should be understood that the arrangement and configuration of the headset **906** and processing unit **904** may be varied as desired. For example, in another example, the communication wires **934** may be omitted or incorporated into the frame or support structure of the headset **906**. FIG. 11 is an isometric view of another example of the headset **906**. With reference to FIG. 11, in this example, the headset **950** may be substantially similar to the headset **906** illustrated in FIGS. 10A-10C, but the communication wires **934** may be incorporated into the material and/or structure of the frame **910**. Additionally, in this example, the headset **920** may include lenses **960** in the front support structure that may be modified based on the needs of the patient. The arms **962** of the headset **950** may extend from each end of the frame **910** and be configured to support the transmitters/receivers **120**, **124** thereon. Additionally, in this example a third transmitter/receiver **120,124** could be configured on the backside of **904**, adjacent to the forehead. As can be appreciated, the process-

ing unit **904** may be smaller and centered on the frame **910**, which provides better mobility for the patient while wearing the headset **906**. Also, as the processing unit **904** is significantly smaller, it may be better able to remain in position and more accurately transmit data to and from the computing device **902** and/or transmitters/receivers **120**, **124**.

[0060] In some embodiments, the processing element **904** or unit is configured to provide transmission data corresponding to one or more of the received magnetic field data as received by the transmitters/receivers to the networking interface, which in turn transmits the transmission data to the external computing device **902**. In these embodiments, the processing element **904** may convert the analog data as received from the transmitters and receivers into digital data before sending the data to the external computing device **902**. This allows the speed of the data transmission between the headset and the computing device **902** to be increased and more reliable.

[0061] The apparatuses and methods described herein may be used, in various embodiments, for fluid measurement (often fluid change measurement) in all parts of the body and for multiple medical diagnostic applications. The configuration of the emitter and detector (detector may alternatively be referred to by receiver) coils may be modified, in various embodiments, to be appropriate to the area of the body and/or the diagnostic application involved. For example, for an application involving a limb, such as the arm, or where it may be more important to measure liquid content at a shallow depth in the tissue, the emitter coil and detector coil may be placed on the same side of the subject tissue. A co-planar arrangement may be appropriate. Since the coils may be separated by a much shorter distance, the received signal strength may be much greater, and the size of the coils may be reduced. In various alternative embodiments, the coils may be in a side-by-side co-planar arrangement or in a concentric co-planar arrangement using coils with different diameters. In some embodiments, it may be more appropriate to place the plane of the coils at a slight angle to conform to the shape of the body part under study.

[0062] With the various examples of the systems described, a method of operating the system will now be described in more detail. With reference now to FIG. 6, one example of the operation of the system **100** will now be briefly described, it being understood that various operations illustrated in FIG. 6 will be described in more detail below, and various alternative methods and modes of operation will also be described below. Beginning at operation **501**, the system **100** is powered on and a self-test is performed. If the system **100** fails the test, a stop or fail indicator is displayed on the laptop **102** in operation **502**. If the system **100** passes the power-on self-test, operation moves to operation **504**. Also, throughout operation of the system **100**, a continuous status monitor may run in operation **503**, and, should the status monitor determine that system **100** is failing, the system may display a stop or fail indicator in operation **502**.

[0063] Once the system **100** passes the power-on self-test and operation has moved to operation **504**, the frequency synthesis FPGA **110** may be initialized and begin to provide the transmitter **120** with the transmit signal in operation **504**. The waveform averager FPGA **112** may begin to collect and average waveforms (e.g., fluid data) from the transmitter **120** and the receiver **124** in operation **505**. The averaged waveforms may be provided to the phase shift measurement FPGA **114**, which may determine the phase shift between the trans-

mitter **120** and receiver **124** waveforms beginning in operation **506**, with the ultimate phase calculation of interest being calculated in operation **507**. The phase calculation may be provided to the laptop **102** in operation **508**. At any point after operation **505**, the frequency synthesizer FPGA **110** may provide another frequency to the transmitter **120**, and the process may repeat for the next frequency. Multiple frequencies may thus be emitted from the transmitter **120** and subsequent phase shifts calculated. For example, the frequency synthesis FPGA **110** may provide the next frequency in repeated operation **504** while the phase shift measurement FPGA **114** measures the phase shift between the waveforms from the previous frequency, or the frequency synthesis FPGA may not provide the second frequency until the phase calculation has been provided to the laptop in operation **508**. In an alternate embodiment, the emitter can emit a single frequency simultaneously with harmonic frequencies, or through the use of multiple frequency generators, for later separation using techniques such as Fast Fourier Transform (FFT). Simultaneous emission of multiple frequencies can be advantageous for noise cancellation, motion rejection and other purposes.

The Transmitter(s) and Receiver(s)

[0064] One range of electromagnetic frequencies appropriate for an inductive phase shift measurement based system **100** for brain fluid diagnostics is in the radio frequency (RF) range from about 20 MHz to 300 MHz, although other frequencies may also be used, such as between 1 MHz and 500 MHz, between 3 MHz and 300 MHz, and so forth. The frequencies chosen may provide relatively low absorption rates in human tissues, good signal relative to noise factors, such as capacitive coupling and signal line cross-talk, and ease of making accurate phase measurements.

[0065] Previously, certain examples of transmitters (and corresponding receivers) that emit (and sense) magnetic fields in these frequency ranges were constructed of thin inductive coils of a few circular turns placed such that the plane of the coil is parallel to the circumference of the head. The coils of these previous transmitters and receivers had diameters of 10 cm or more and 5 or more turns. These relatively large transmitter and receiver coils, however, were cumbersome and furthermore had resonances within the range of the frequencies of interest for VIPS detection of fluid in a human brain. When transmitter or receiver coils are operating in a frequency near one of their natural resonant frequencies, a measured phase shift may be largely a function of the magnitude of the coil's own parasitic capacitances, and very small changes due to motion of either of the coils and/or environmental effects can cause large changes in the phase shift, creating unacceptable noise in the measurement of phase shift.

[0066] Accordingly, in some embodiments of the present disclosure, the lowest natural resonant frequency of the transmitter **120** and/or receiver **124** may be higher than the intended frequencies of the magnetic fields to be transmitted. In some examples, the transmitter **120** may include a coil as a magnetic field generator or transducer. From symmetry considerations, this same or a similar coil may act as a magnetic field sensor in a receiver **124**. In either case, as the diameter of the coil and number of turns (i.e., loops) is reduced the first self-resonant frequency generally increases. The limit, therefore, is for a coil with a single loop, the loop having a very small diameter. As the loop diameter decreases, however, the

amount of magnetic flux intercepted by the loop is reduced by a factor equal to the ratio of diameters squared. Likewise, the induced voltage in the loop is reduced, resulting in a smaller signal from a loop acting as a magnetic field sensor in a receiver **124**. Thus, there are practical limits on the diameter reduction. In some embodiments, however, an additional increase in the self-resonant frequency can be achieved by using transmission line techniques in the construction of the transmitter **120**/receiver **124**.

[0067] An alternative to using coils designed for a relatively constant phase shift over a wide bandwidth is to add external reactive components in a series-parallel network to tune out the phase shift at a single frequency or at a small number of discrete frequencies. This concept works best if the approximate value of the individual frequencies is known prior to designing the overall system and the number of discrete frequencies is small. By using switched or motor driven tunable components, the phase shift tuning can be automated and software controlled. An advantage of tuning to a constant phase shift is that it provides more freedom in the choice of the size and shape of the coils. Using larger coils can increase the detected signal strength and provide a field shape that is optimally matched to the portion of the brain or other body part that is being sampled.

[0068] In one embodiment, with reference to FIG. 2A, a single loop **250** with a high self-resonant frequency and associated stable phase response below the self-resonant frequency may be constructed using a shielded transmission line, such as coaxial cable, buried strip-line on a printed circuit board, a twisted shielded pair of wires, a twinaxial cable, or a triaxial cable. The loop **250** may be used as either a magnetic field generator in the transmitter **120** or as a magnetic field sensor in the receiver **124**. The shielded transmission line may include a first conductor as a shield **251** that at least partially encloses a second conductor. The first conductor or shield **251** may be grounded and may form a faraday cage around the second conductor. The second conductor may provide an output signal responsive to the changing magnetic field, and, due to the faraday cage, the second conductor may be shielded from external electrostatic effects and from capacitive coupling. For example, in one embodiment, a single loop **250** of buried strip line may be sandwiched between two grounded planes in a printed circuit board. A plurality of vias may extend between the two grounded planes, with the spacing of the vias determined by the wavelengths of the electromagnetic field being transmitted and/or received, and the vias together with the two grounded planes forming an effective electrostatic or faraday cage around the buried strip line loop **250**. In other embodiments, other types of transmission lines with an outer shield (such as coaxial cable) may be used in order to form a faraday cage and thus reduce external electrostatic effects on the loop **250**.

[0069] In single loop **250** embodiments of a transmitter **120** or receiver **124**, the voltage of the loop **250** may not be in phase with the current of the loop **250** due to the inductive nature of the single loop **250**. This phase error may be detected and accounted for during initialization of the diagnostic system **100**, as described below. In some embodiments of the single transmitter loop **250**, however, and with reference to FIG. 2B, a balun transformer **254** may be added, in order to obviate the need to correct for this phase error. In still other embodiments, and with reference to FIG. 2C, a second, independent, smaller, concentric loop **260** is used to sense the transmitted magnetic field and provide a current representa-

tive of the same to the A to D converter. The second, concentric transmitter loop 260 may in some examples be the same size as the corresponding receiver loop (e.g., in receiver 124) in order to have proportional signals and good uniformity between them, whereas in other examples the receiver loop may be larger than the second, concentric transmitter loop 260 in order to be more sensitive to the received magnetic field. In those transmitters 120 with the second, concentric transmitter loop 260, and with reference to FIG. 2D, a balun transformer 264 may likewise be used on this second, concentric loop 260 in order to balance the sensed voltage and current. Furthermore, for a single-turn receiver loop 250, a balun 254 may likewise be added in order to also balance its performance, similar to that shown for the transmitter cable in FIG. 2B.

[0070] Referring now to FIG. 2E, in another embodiment, the transmission line concept may be extended from building a single-loop, single-ended device to building a dual-loop 270, which may be double-ended or “balanced,” for use as a receiver 124 (or, symmetrically, for use as a balanced transmitter 120). In FIG. 2E, four conductive (e.g., copper) layers 271, 272, 273, 274 may be formed on a printed circuit board as shown, with three layers of dielectric material (not shown in FIG. 2E) coupled between the four conductive layers 271, 272, 273, 274 when stacked vertically. The top and bottom layers 271, 274 may be grounded and thus form an electric shield. Furthermore, small linear breaks 271A, 274a may be present in both of the top and bottom layers 271, 274 so that the ground planes 271, 274 don't act like additional shorted turns. In between the top and bottom ground layers 271, 274, the +loop 273 and the -loop 272 may be positioned, with the leads from the two loops 272, 273 being coupled to a balanced amplifier (not shown in FIG. 2E). The +loop 273 and the -loop 272 may be center tapped in some examples. The inner diameter of the two loops 272, 273 may be approximately 1 inch, and may be slightly greater than the inner diameter of the circular void in the two grounded planes 271, 274. In some embodiments, the thickness and permittivity of the dielectric material, the width and thickness of the conductive material forming the loops 272, 273, the spacing of the ground planes 271, 274, and so forth, may be chosen such that the double loop 270 has approximately a 50 ohm impedance in order to match the transmission line to which it will be coupled. In this manner, the self-resonant frequency of the dual loop structure 270 may be above 200 MHz in some examples.

[0071] Still with reference to FIG. 2E, for a dual loop 270 used as a magnetic field sensor in a receiver 124, external noise that is coupled into the system 100 from environmental changes in the magnetic field due to environmental EMI sources or motion of nearby conductors or magnetic materials may be reduced due to the common-mode rejection of the differential amplifier to which the two loops 272, 273 are coupled. Having the differential amplifier coupled to the loops 272, 273 when used as a receiver 124 thus may allow the loops' 272, 273 diameters to be reduced while keeping the output signal level at a suitable level for transmission to a remote processing unit 104 (e.g., for those systems where one or more A to D converters are not located directly in the headpiece 106). The amplifier power gain may be approximately 40 db in some embodiments. Low-cost wide-bandwidth amplifiers offering gains of 40 db for the power levels of interest are readily available in miniaturized packages from multiple suppliers with negligible phase shift variation over a 20 MHz to 200 MHz frequency range.

[0072] With reference to FIG. 2F, as suggested, the dual loop 270 used for a balanced receiver 124 has an analogous application as a magnetic field generating transmitter 120. The balanced approach for constructing a transmitter 120 may result in a common-mode cancellation of noise in the transmitted magnetic field due to the opposite winding directions of the dual loops, thus reducing noise in the transmitted magnetic field that may otherwise result from electrostatic or magnetic pickup from environmental factors.

[0073] Referring still to FIGS. 2E and 2F, in some embodiments, the two loops 272, 273 may be formed in different planes, or, in other embodiments, the two loops may be fabricated in the same plane with concentric circular strip-line traces (thus reducing the number of layers required in fabricating the pc board). This concentric design may be used for the transmitter 120, and/or the receiver 124.

[0074] Also, with reference to any of FIGS. 2A through 2F, in examples where the analog to digital conversion is not done proximate the transmitter 120 or receiver 124, a resistive attenuator may be added to the pc board with surface-mount resistors in order to help reduce cross-coupling of the transmitter signal to the receiver signal in the cable through which the analog signals are transmitted, which may help increase phase measurement accuracy and stability. The on-board attenuator may result in a substantial size and cost reduction compared with a bulky separate modular attenuator. Also, still continuing with examples where the analog to digital conversion is not done proximate the transmitter 120 or receiver 124, with reference still to any of FIGS. 2A through 2F, one or more amplifiers may be provided to amplify the signals from the transmitter 120 and/or the receiver 124 in order to reduce attenuation of the signals through the cable to the external analog to digital converter 122, 126. Still continuing with examples where the analog to digital conversion is not done proximate the transmitter 120 or receiver 124, the voltage on the transmitters and receivers may be in phase with current on the respective transmitters and receivers because the “balanced” transmitter and receivers illustrated in FIGS. 2E and 2F are terminated in the 50 ohm characteristic impedance of coaxial line.

[0075] Referring now to FIG. 3, an alternative design may include an amplifier 256 on the same printed circuit board as the loop 250. Including an amplifier 256 on the same printed circuit board as the loop 250 (that is used, for example, as a receiver 124) may help increase the signal to noise ratio, which may be particularly useful for embodiments where analog to digital conversion is done remotely from the headpiece 106. An amplifier 256 may also be used in embodiments where analog to digital conversion of a signal is done near the loop 250. As mentioned above, a balun transformer may be also included on the printed circuit board between loop 250 and the amplifier 256, which may help cause the coil to operate in a “balanced” mode. In the balanced mode, capacitively coupled electromagnetic interference pickup or motion induced fluctuations in the signal level may be reduced or canceled, since they typically equally couple into both the negative and positive leads of the balanced differential signal.

Initialization: Air-Scan to Remove Fixed-Phase Errors

[0076] As suggested above, the diagnostic system 100 may be initialized in some examples in order to calibrate the transmitter 120 individually, the receiver 124 individually, the transmitter 120 and the receiver 124 with one another and with the other associated electronics, and so forth. For

example, variations in lead lengths and amplifier time delays in signal paths from the transmitter **120** and receiver **124** may be detected during initialization and removed from the signals during signal processing in order to prevent fixed offset errors in the data. Also, any phase shift between (measured) voltages and currents in a single-turn loop **250** may be detected.

[0077] The initialization may in one embodiment be an “air-scan” where the transmitter(s) **120** and receiver(s) **124** are positioned with only air between them, the transmitter(s) **120** and receiver(s) **124** positioned approximately as far apart as they would be if they were positioned on the head of an average patient. Once thus spaced, phase shift data is collected for a range of different frequencies (because the errors may be constant across or varying among different frequencies), and the collected air-scan values may be subsequently used during signal processing to correct any phase shift errors of the system **100** (e.g., by subtracting them from the values obtained during operation of the system **100**). The initialization may be done when the A to D converters **122**, **126** are in the headpiece **106** proximate to the transmitter **120** and receiver **124**, when the A to D converters **122**, **126** are external to the headpiece **106**, and so forth.

Generation of the Driving and Sampling Signals

[0078] As mentioned above, the diagnostic system **100** collects phase shift data for transmitted time-varying magnetic fields at multiple frequencies because the phase shifts contributed by various tissue types and body fluids may vary with frequency. The diagnostic system **100** illustrated in FIG. **1** provides a flexible frequency synthesizer **100** within the processing unit **104**, although in other embodiments, a frequency synthesizer **110** may be provided in, for example, the headpiece **106**. This frequency synthesizer **110** may have a minimum of 1 MHz resolution over the range of about 20 MHz to 200 MHz in some examples (or alternatively about 20 MHz to 300 MHz or about 10 MHz to 300 MHz or any of a number of other suitable ranges). Standard digital phase-lock loop techniques may be used to derive the selectable frequencies from a single stable crystal-controlled clock oscillator. As described above, the digital portions of the synthesizer **110** may be implemented in one of the FPGAs **110** in the processing unit **104**. The synthesizer **110** may produce both a basic square wave clock signal for generating the magnetic field in the transmitter **120** as well a sampling signal. The sampling signal may be at a slight offset (e.g. 10 KHz) in frequency from the magnetic field generating signal in some embodiments. The square wave signal for generating the magnetic field may, in some embodiments, be amplified to correct its level and may also be filtered to eliminate higher order harmonics and achieve a low distortion sine wave at one or more fundamental frequencies.

[0079] In other cases, where frequency domain techniques such as FFT processing of the time domain data are used to calculate phase, it may be advantageous to accentuate the harmonics of the fundamental frequency. For these embodiments, additional circuits may be added after the basic frequency synthesizer to make the rise-time or fall-time of a square-wave or pulse wave-shape much faster, thereby increasing the relative amplitude and number of higher order harmonics. As mentioned previously, this embodiment allows generation of a “comb” of frequencies with a single burst of RF and the processing of the captured time domain data from the emitter and detector using Fourier techniques yields a simultaneous time correlated phase difference data

set for each frequency in the “comb”. This simultaneous capture of phase data from multiple frequencies may yield significant advantages for separating the desired information about the patient’s brain fluids from motion artifacts or other effects that would affect an individual scan of the frequency where the phase data for each frequency is measured at different times. Sampling each frequency at different times in this case introduces noise that may be difficult to detect or remove.

[0080] As the signal used to generate the magnetic field is typically periodic, it may not be necessary to use a sampling frequency that is many times greater than the frequency of that signal to capture the phase information from a single cycle of the waveform, and instead an under-sampling technique may be employed in some examples. Under-sampling is similar to heterodyning techniques used in modern radios where a large portion of amplifier gain and the audio or video signal demodulation is performed in much lower intermediate frequency stages of the electronics (IF). Under-sampling, in effect, allows a system to collect the same or a similar number of sample points over a longer period of time, while not disturbing the phase information of the signal.

[0081] Using under-sampling may eliminate the need for high-speed A to D converters (which are expensive and may involve many different wired connections) that may otherwise be required to capture enough phase samples from a single cycle of the waveform to accurately measure phase angle. If a lower speed A to D converter may be used, it may be commercially and physically practicable to position the A to D converter **122**, **126** proximate the transmitter **120** and receiver **124** loops **250**, **270**, as described above.

[0082] Therefore, in some embodiments, one or both of the transmitted and received magnetic field signals may be under-sampled (e.g., with one sample or less for each cycle) and an average record of the waveform may thus be captured using samples taken over a much longer interval of time compared to one cycle. In order to accomplish the under-sampling, both the transmit signal and the sampling signal may be derived from a common clock signal, with the sampling signal being accurately offset from the transmit signal frequency (or a sub-harmonic frequency) by a small amount. If the offset is, for example, 10 KHz from the first harmonic frequency of the transmit signal, the result after a period of 100 microseconds will be an effective picture of one cycle of the repetitive transmit waveform with $f/10000$ individual samples. For a transmit signal frequency of 100 MHz and sample frequency 100.010 MHz, the 10,000 under-sampled individual samples of a single cycle of the transmit waveform are spaced at a resolution of $360/10000$ or 0.036 degrees. As one alternative to under-sampling, frequency conversion using standard non-linear mixing technology before an A to D converter **122**, **126** may also be employed.

[0083] In other examples, the frequency of the magnetic field generator signal and the frequency of the sampling signal may be otherwise related, one example of which is described below when referring to frequency domain signal processing techniques. In still other examples, the sampling frequency may be relatively constant (e.g., 210 MHz, while the generating frequency may vary over a wide range).

Conversion of the Transmitted and Received Analog Signals to Digital Data

[0084] In some embodiments, electronic phase shift measurements between the transmit and receive signals may be

performed using analog signal processing techniques, whereas in other examples the phase shift measurements may be performed after converting the analog data to digital data through one or more A to D converters **122**, **126**, as described above. The digital waveforms may then be processed to obtain the relevant phase shift information. Processing digital data rather than analog data may facilitate sampling and averaging many cycles of the waveforms in order to, for example, reduce the effects of random noise and, with proper techniques, even reduce non-random periodic noise such as AC line pickup at frequencies near 60 Hz. Also, after reducing the noise in the waveform data there are many methods, such as correlation, that may be employed to obtain accurate phase measurement using digital signal processing.

[0085] In some examples of the diagnostic system **100** described herein, the A to D conversion of both the transmitted and the received signals is performed as close as feasible to the point of generation and/or detection of the magnetic fields. For example, the A to D conversion may be performed in the headpiece **106** by miniaturized monolithic single chip A to D converters **122**, **126** located integral to the printed circuits that, respectively, contain the transmitter **120** and receiver **124**. The A to D converter **122** for the transmitter **120**, for example, may differentially sample the voltage across the balanced outputs of the transmitter **120** in one example. The A to D converter **126** for the receiver **124**, for example, may be positioned at the output of a wide bandwidth signal amplifier coupled to the receiver **124**. By locating the A to D converters **122**, **126** on the headpiece **106** rather than in a remote processing unit **104** (which may, however, be done in other embodiments described herein) it may be possible to reduce or eliminate the effects of phase shifts associated with motion, bending, or environmental changes on the cables carrying the analog signals to the A to D converters **122**, **126**. Other sources of error that may be reduced or eliminated include cable length related standing-wave resonances due to small impedance mismatches at the terminations and cross-coupling between the transmit and receive signals on the interconnecting cables that generate phase errors due to waveform distortion. To realize similar advantages in an embodiment where the A to D converters **122**, **126** are not located proximate the transmitter **120** and receiver **124**, a single cable may be used to bring the sampling signal to the transmitter and receiver A to D converters **122**, **126** in the processing unit **104**, and/or a high quality semi-rigid cable may be used between the two A to D converters **122**, **126** in some embodiments.

Overall Operation and Pipelining

[0086] Referring again to FIG. 1, the waveform data (which may be under-sampled in some embodiments) may be captured for both the transmitted and received magnetic fields, and the captured waveforms may be at least partially processed in real-time (or substantially real-time). As described herein, one FPGA **112** may average the data for each of the two waveforms over many cycles for noise reduction. Another FPGA **114** may then use a correlation technique to perform a phase shift measurement using the averaged waveform data. A pipelining technique may be used in some embodiments to speed up the data throughput for collection of phase data over multiple frequency samples. The transmitter **120** may generate a time-varying magnetic field at a first

desired frequency, and the requisite number of waveform averages may be performed by the waveform averager FPGA **112** at this first frequency.

[0087] After the averager FPGA **112** collects and averages all of the sample data points from the transmitter **120** and receiver **124**, it may transfer the same to the phase shift measurement FPGA **114**. In some embodiments, only a single transmit frequency is used in diagnosing a fluid change in a patient, but in other embodiments, a plurality of different transmit frequencies within a desired spectral range may be generated and the corresponding data collected. In those embodiments with multiple transmit frequencies, phase determination for a first transmit frequency may proceed in the phase shift measurement FPGA **114** (using the data acquired during the first transmit frequency) while the frequency synthesizer FPGA **110** causes the transmitter **120** to generate a magnetic field having a second desired frequency of the spectral scan and the waveform data from the second transmit frequency is averaged by the waveform averager FPGA **112** (hence the pipelining). In other embodiments, the waveform averaging for one transmit frequency may occur substantially simultaneously with recording a plurality of samples for a second frequency. In general, many different types of pipelining (e.g., performing two or more parts of the signal generation, acquisition, and data processing at substantially the same time) may be used. In other embodiments, however, there may not be any pipelining, and the diagnostic system **100** may transmit, collect, average, and process all of the data relating to a single transmit frequency before moving to a second transmit frequency.

[0088] Regardless of whether pipelining is used, the process of using different transmit frequencies may be repeated for any number of transmit frequencies with a desired spectral frequency scan, and may also be repeated for one or more frequencies within the spectral scan. The calculated phase shifts for each frequency may be transferred to the laptop **102** directly from the phase shift measurement FPGA **114** in some examples.

Signal Processing—Averaging

[0089] Because of the relatively small size of the transmitter **120** and the receiver **124**, as well as the relatively low power of the transmitted magnetic field (it is low power because of, among other things, the need to protect a patient from overexposure to RF radiation and the need to minimize electromagnetic field emissions from the system **100**), the measured magnetic field at the transmitter **120** and/or at the receiver **124** may have relatively large amounts of noise compared to its relatively small amplitude. The noise may include input thermal noise of an amplifier, background noise from EMI pickup, and so forth. In some embodiments, the noise may contribute a significant fraction to the phase shift measurements relative to the actual phase shift. For example, 1 ml of fluid change may correspond with a 0.3 degree phase shift, and thus if the noise in the transmit and receive signals is a substantial portion of, or even exceeds, the expected phase shift, the noise may render the data unacceptable.

[0090] In order to reduce the noise, the diagnostic system **100** described herein may, in some embodiments, sample many cycles of the transmitted and received magnetic fields (e.g., many multiples of 10,000 samples, such as 32,000 samples) and may average the individual samples in order to substantially reduce random noise or filter specific frequencies. In some examples, the total sampling time interval may

be extended to be an approximate integer multiple of one 60 Hz AC power period in order to reduce the effect of 60 Hz related electromagnetic interference pickup. As explained below, these waveforms may be averaged by any appropriate averaging technique, including multiplying them by one another in the time domain, as well as other frequency domain averaging techniques.

[0091] Referring now to FIG. 4, one embodiment 300 of a simplified logic diagram of the waveform averager FPGA 112 is shown. Of course, in other embodiments, custom circuitry may be employed to average data, which custom circuitry may be located in headpiece 106, in processing unit 104, in laptop 102, or in another suitable location. FIG. 4, however, illustrates one example of logic that may be implemented in the waveform averager FPGA 112 for averaging the transmitted waveform samples after they have been digitized by an A to D converter. Similar logic 300 may be used to average the received waveform samples after they have been digitized. The input to the waveform averager FPGA 112 may be a low voltage differential signaling (LVDS) type of format from the A to D converter, in order to reduce the wiring needed between an A to D converter and the waveform averager FPGA 112. In the LVDS format, each word of digital data representing a single waveform data-point may first be converted from serial data to parallel data by the deserialization logic described below.

[0092] The logic illustrated in FIG. 4 includes a synchronous serial-in, parallel-out shift register 301 that is clocked by the data transfer clock from the A to D converter. The parallel data words are then transferred into a memory buffer 302 with sufficient capacity to handle the maximum number of individual waveform samples required to construct one complete cycle of the transmitted waveform. An adder 303 may be used to accumulate the sum of all of the waveform samples in the memory buffer 302 as the data words exit the register 301 or after the memory buffer 302 is fully populated. Each waveform sum memory location may have a word size in bits that can accommodate the largest number expected for the sum without overflow. For example, a 12 bit resolution A to D converter and 4096 waveform sum requires a 24-bit memory word size. After accumulating the sum of the intended number of waveforms in the waveform memory for the transmitted signal samples (and, separately, the receiver signal samples are similarly summed in a waveform averager), the memory contents for both waveforms are serially transferred to the phase shift measurement FPGA 114. It may not be necessary to divide by the number of waveforms being averaged in some examples because, in the next step of the processing, only the relative magnitudes of the data-points in the averaged waveforms may be relevant. Because of this, an appropriate number of least significant bits may also be deleted from each of the averaged waveform data points without significant impact to the accuracy of the overall phase shift determination.

Signal Processing—Determining Phase Shift

[0093] Referring now to FIG. 5, the phase shift measurement FPGA 114 may also contain two revolving shift registers 401, 402, a multiplier 403, and an adder 404. It may also include logic configured to calculate the sum of the product of the individual transmit and receive averaged waveform data points with an adjustable phase shift between the two waveforms. The FPGA may be used to find the phase shift where

the sum of products is closest to zero and the slope of the sum of products versus phase shift is also negative.

[0094] Consider the following trigonometric identity for the product of two sine waves with frequency f and phase shift ϕ :

$$\sin u \sin v = 1/2[\cos(u-v) - \cos(u+v)] \text{ where } u = 2\pi ft + \Phi \text{ and } \quad (\text{Eq. 1})$$

$$\begin{aligned} v &= 2\pi ft \\ &= 1/2[\cos(\Phi) - \cos(2\pi(2F)t + (\Phi))] \end{aligned} \quad (\text{Eq. 2})$$

[0095] The first term of the product is a DC term dependent only on the phase shift. The second term is another sine wave at twice the frequency which averages to zero over one complete cycle of the original frequency. Note that the first term (a cosine wave) is also zero when the phase angle (ϕ) is either $+90^\circ$ or -90° . Furthermore the slope of the product with respect to phase angle changed $(\sin u \sin v)/d\phi$ is negative for $\phi=+90^\circ$ and positive at $\phi=-90^\circ$.

[0096] By iteration, the FPGA may determine the value of n_{offset} where the transmitted wave and received wave are closest to a $+90^\circ$ phase shift. For an offset of n_{offset} samples, and n_s samples for one complete 360° waveform, the phase shift is then calculated using the following equation:

$$\text{Phase shift} = 90^\circ + (n_{offset}/n_s) * 360^\circ \quad (\text{eq. 3})$$

[0097] The resolution of the determination may be limited to the number of samples ($\text{resolution} = 360^\circ/n_s$). If this resolution is insufficient for the needed precision of the measurement, then interpolation may be used to find the fractional value of n_{offset} where the sum of product terms exactly passes through zero.

Frequency Domain Signal Processing Methods for Phase Shift Measurement

[0098] As explained above (see e.g., sections on averaging and multiplying waveforms together to obtain phase shift data), the signal processing of the measured and digitized magnetic field traces from both the transmitter 120 and the receiver 124 may proceed in the time domain. In other embodiments, however, the signals may be processed in the frequency domain using, for example, Fast Fourier Transforms (FFTs)

[0099] In one embodiment of Fourier domain analysis, the signals from the transmitter 120 and receiver 124 are digitized at, for example, about a 200 MHz sampling rate with a relatively high resolution (e.g., 14 bits). The A to D converter and the data capture electronics may be included in a relatively small printed circuit assembly packaging. The captured data may be transferred via a high-speed USB serial link to the laptop computer 102. Time domain processing can then be replaced by frequency-domain processing on the laptop 102 to calculate the phase shift between the waveforms.

[0100] Once the data is on the laptop 102, the FFT for each of the transmitter and receiver time domain waveforms can be calculated (in other embodiments, however, the FFT may be calculated by an FPGA or other processor proximate the A to D converters). The resulting real and imaginary solutions which represent the resistive and reactive frequency domain data can then be converted from cartesian to polar coordinates, thus yielding frequency domain plots of the magnitude and phase of the waveforms. The phase of each waveform can

be obtained from the frequency domain plots of phase for the frequency of interest. If the fundamental frequency is off-scale, then a difference frequency between the sampling frequency and the transmitted wavefield frequency can be used. For example, a sample frequency of 210 MHz yields an FFT with a frequency range of 0 to 105 MHz, and the fundamental frequency is used for phase shift measurement when the transmitted wavefield frequency lies in this range. The difference frequency is used if the transmitted wavefield frequency is in the higher end of the range, for example, 105 MHz to 315 MHz.

[0101] After the FFT for both of the transmitted and received wavefield signals is calculated, the phase shift for a particular frequency of interest can then be calculated from the difference of the phase values obtained from the transformed transmitter and receiver waveforms. Note that some sign reversals for the phase information in various frequency regions may be needed when calculating the shift.

[0102] In order to allow FFTs to be computed for samples from the transmitter **120** and the receiver **124**, the frequencies used for the sampling and the transmitted waveform may be determined so as to allow coherent sampling so that both the transmitted and received waveforms contain an integer number of complete time periods of the repeated waveform, and the number of samples collected for the waveforms is an even power of two. One method for implementing coherent sampling is to choose transmitter and receiver sampling frequencies such that $\text{prime}_1/f_{\text{transmit}} = \text{prime}_2/f_{\text{receive}}$. The prime numbers prime_1 and prime_2 , as well as the number of samples, can be very large in some embodiments, thereby reducing the spacing between the allowable values for the signal frequencies (e.g., the tuning resolution may be approximately 1 Hz). This may be accomplished by using digital frequency synthesis techniques, such as by combining a stable frequency source and the appropriate combinations of integer frequency multipliers, integer frequency dividers, and phase lock loops.

[0103] With coherent sampling, the theoretical accuracy of the phase calculation may only be limited by the number of samples of the time domain waveform and the digital resolution of the A to D converter. Dc noise and low frequency noise sources such as 1/f noise may be inherently rejected by the frequency domain processing technique. The use of coherent sampling also reduces the probability that harmonic and intermodulation product frequency components will lie on top of the frequencies of interest for calculating phase. Furthermore, using an FFT frequency domain solution to determining phase may provide information regarding the magnitude or amplitude of the measured transmitted and received magnetic fields. The ratio of the magnitude values can be used to determine the attenuation of the transmitted magnetic field, which may be expressed in logarithmic dB power ratio units.

Alternative Signal Processing in the Time Domain

[0104] As one additional alternative signal processing technique in the time domain, the phase shift measurement may be done via one or more relatively low-cost analog phase detectors or by measuring time delays between zero crossings of the transmitted and received wavefield signals. For example, an integrated phase detector circuit may include an amplifier that converts sine waves of transmitted and received wavefields to square waves by clipping the sine waves (e.g., with an extra high gain), and then compares the clipped/square wave from the transmitter with that from the receiver

using an analog exclusive OR (XOR) gate, with the pulse width provided by the XOR gate being indicative of the phase shift between the transmitted and received magnetic fields.

Reduction of Phase Measurement Errors Due to Motion

[0105] Among all of the factors that contribute to phase measurement error, many are related to motion—motion of the patient, movement of the transmitter **120**, movement of the receiver **124**, bending of the connection or transmission cables, etc. For example, relative motion between the patient and the transmitter **120**/receiver **124** results in path length and location variations for the magnetic field lines as they pass through the patient's head. Conductive or magnetic objects moving near the transmitter **120** and/or near the receiver **124** can also change the shape of the magnetic field lines as they pass from the transmitter **120** to the receiver **124**.

[0106] In some embodiments, methods may be deployed to reduce artifacts attributable to patient movement. These algorithms may, for example, detect statistical variations in the differential phase shift data across the frequency spectrum of interest (e.g., from about 30 MHz to 300 MHz or about 20 MHz to 200 MHz) that could not possibly be the result of biological changes, as determined by their rates of change or other characteristics. This thresholding-type of method may thus be used to eliminate data corrupted by means other than true biological changes.

[0107] As another example, the attenuation data that is obtained from the magnitude portion of the FFT processing can be utilized in algorithms by examining the way it varies across the frequency spectrum to aid in the detection and correction of motion artifacts in the phase shift data.

[0108] As still another example, electronic accelerometers can additionally or alternatively be used to detect motion of one or more of the transmitter **120**, the receiver **124**, the patient, or the transmission cables. In some examples, accelerometers may be coupled to the same printed circuit board as the transmitter or receiver (e.g., using a MEMS type accelerometer).

[0109] In addition to detecting any motion above a threshold level, a relationship between the transmitter/receiver accelerometer data and patient accelerometer data may be examined for relative differences. For example, small amplitude changes sensed in both the patient and the transmitter/receiver may be of little consequence. Some patient motion is almost always present (because, e.g., even comatose patients breathe). Larger or non-correlated accelerometer readings, however, may be used to trigger data rejection or correction. Because the separate motion of totally independent objects near the patient can also present motion artifacts in the data then some types of motion detection and correction based on statistical analyses of the phase data may still be required.

Medical Diagnostic Methods for Alerting Clinicians

[0110] The system **100** described herein may be used to, among other things, measure the change in phase shift induced by changes in fluid content within, for example, a patient's head ("intracranial fluid"). Methods can be employed to analyze the phase data and make a determination as to whether the fluid change represents a tissue change that is troubling to the clinician user. For example, a baseline reading of the phase shift between a magnetic field transmitted from a transmitter **120** positioned on one side of a patient's head and a magnetic field received at a receiver **124**

positioned on the other side of the patient's head at one or more frequencies may be recorded when the patient first arrives at the hospital. Then, any significant changes in the measured phase shift that occurs during subsequent scans can be tracked and trended by clinicians to aid in understanding the patient's clinical condition, and certain thresholds, patterns or trends may trigger an alarm. Many methods may be employed and optimized to provide the clinicians with the most useful fluid change information. For example, if the phase shifts by more than a certain number of degrees, the system may sound an alarm to alert the clinician that the patient may have clinically significant bleeding or edema. For some conditions, it may be useful to alert the clinician if the rate of change of the phase shift exceeds a threshold.

[0111] The phase shifts at different frequencies may vary with different fluid changes, as described, for example, U.S. Pat. No. 7,638,341, which is hereby incorporated by reference in its entirety for all purposes. Certain patterns of phase shift may be correlated with certain clinical conditions. For example, a condition such as bleeding or edema may be evidenced by an increase in phase angle at one frequency, with a concurrent decrease at a different frequency. Using ratios of phase shifts at different frequencies can provide additional information about the types of fluids and how they are changing. For example, the ratio of phase shift at a first frequency to the phase shift at a second frequency may be a good parameter to assess blood content or to separate edema from bleeding or other fluid change. For example, the phase shift frequency response of saline may be different from the phase shift frequency response of blood, thus allowing a clinician to separately identify changes in blood and saline content in a patient's brain cavity. Changes in amounts of water may have relatively little effect on phase shift in some instances, although the concentration of electrolytes in an ionic solution may have a more pronounced effect.

[0112] The phase shift patterns may also be time dependent. A hypothetical clinical condition may be characterized by an increase in phase shift for some period of time, then stabilizing, and then returning to baseline after some other time period. Noise factors such as patient activities like getting up out of bed, eating, getting blood drawn or speaking with visitors may cause changes to the phase shift readings from baseline. Clinically meaningful fluid changes may be differentiated from noise by examining the patterns associated with different activities.

[0113] Using combinations of phase shift and/or attenuation data at various frequencies, ratios or other functions of those phase shifts and/or attenuations, and/or time-based methods may all be combined and optimized in various embodiments to provide a range of useful information about tissue and/or fluid changes to clinicians. The clinicians can then respond to the tissue changes by using more specific diagnostic techniques such as medical imaging to diagnose a clinical problem.

[0114] In some cases, therapies may be changed in response to fluid and/or tissue change information. For example, the diagnostic system described herein may monitor fluid changes in a patient who is on blood thinners to dissolve a clot in a cerebral artery. If the system detects an intracerebral bleed, the blood thinners may be reduced or stopped to help manage the bleeding, or other interventions such as vascular surgery may be performed to stop the bleeding. As another example, a patient who begins to experience cerebral edema may undergo medical interventions to control or reduce the

edema, or can undergo surgical procedures to drain fluid or even have a hemispherectomy to reduce intracerebral pressure due to the edema.

[0115] Clinicians may, in some cases, use fluid change information to manage medication dosage by examining what is effectively feedback from the diagnostic system. For example, if mannitol is used to reduce intracerebral pressure by drawing water out of the brain, a treating clinician may use the diagnostic system described herein in order to receive feedback regarding how the patient's brain water is changing in response to the medication.

[0116] Similarly, drugs for blood pressure management, electrolyte concentration and other parameters may be more effectively administered when dosage amounts are controlled responsive to feedback from the diagnostic system described herein. For example, cerebral sodium concentrations may be controlled using intravenous hypertonic or hypotonic saline solutions. Changes to the ion concentrations can be detected as a shift in phase angle or some function of shift in phase angle at one or more frequencies. Such information can be used as feedback to the physician to better manage the patient.

Additional Embodiments

[0117] One embodiment of a VIPS system for monitoring intracranial/brain fluid(s) houses all of the electronics in the headpiece **129**. The headpiece **129** could be constructed like a helmet or hardhat. The radiofrequency oscillators can be placed near the emitter or multiple emitters **120/124**, potentially on the same printed circuit board. One oscillator can generate the transmitter signal, and another oscillator can be used to generate the sampling signal. As will be discussed later, multiple transmitters or receivers may be used, and it may be desirable to have different oscillators for different transmitters. Therefore, multiple oscillators may be used. In another embodiment, the headpiece **129** could be constructed like a pair of spectacles. One advantage of such an embodiment is that the position may be better controlled because the device would be mechanically registered to the nose and two ears, making it possible to remove and replace the device with good repeatability of antenna location. The antennas can be placed on the temples of the glasses, just above and in front of the ears, providing a location approximately at the center of the brain. The antenna placement near the ears has the feature of being close to the mechanical reference points, and therefore providing for good position repeatability.

[0118] In some embodiments, multiple transmitters may be used, transmitting frequencies that are offset from each other. For example, three transmitter antennae may be used, and each antenna may transmit a frequency that is several KHz different from the others. The frequency of all three oscillators should be derived from the same stable reference oscillator, using digital phase locked loop synthesis techniques to reduce phase errors due to the differences in thermal frequency drift and phase noise of separate oscillators. One advantage of having slightly different frequencies for each transmitter is that the system could then identify and separate out the signals produced from each transmitter, for example, using a Fast Fourier Transform (FFT). Using this technique, all transmitters could briefly be powered on simultaneously, and all of the received phase information for each transmitter/receiver combination could simultaneously be determined using FFTs of the transmitted and received waveforms for the same extremely small time interval. This information can allow the system to resolve the location of a fluid change

within the tissue and also differentiate from phase changes caused by motion of the patient, tissue fluid flow, or motion of the antennae or field motion generated from moving objects in the environment. For example, such a system may be used to specifically identify the location of a hematoma or volume of ischemia inside the brain of a patient.

[0119] For medical applications, it may be desirable to transmit signals within the industrial, scientific and medical radio band (referred to herein as the “ism band”). However, it may be desirable to design the system to transmit outside this band so as to reduce exposure to more ambient radiofrequency noise coming from other devices operating in the ism band.

[0120] In order to improve the system’s robustness against ambient radiofrequency noise, the system can detect the ambient radiofrequency noise during time periods when the oscillators are not transmitting any signals. If the noise at certain frequencies is too high, then the system can shift to generating signals at a different frequency, thus improving the signal-to-noise ratio. In some applications, it may be desirable to use spread spectrum techniques for measuring the phase, in order to spread the electromagnetic interference frequencies over a wider range of frequencies to improve the signal-to-noise ratio. To facilitate changing frequencies, multiple crystals could be installed in the device, and the system could select between the crystals to allow for selecting the most appropriate frequency given the noise environment. Alternately, the digital RF frequency synthesizer could have sufficient bandwidth and resolution to facilitate rapid frequency synthesis for the new frequencies from a single reference crystal oscillator. If necessary, the reference crystal oscillators could be oven stabilized to further reduce phase errors from temperate drift.

[0121] When generating the signals, a variety of wave shapes may be employed. A square wave will provide more power at harmonics of the fundamental frequency. Sine waves and distorted square waves can be used to push more of the radiofrequency power into the higher frequencies, or to provide power at various harmonic frequencies. Alternatively, a base frequency and higher frequency can be summed together for additional power at the different frequencies. A separate RF frequency may also be required for the sample signal for analog to digital conversion. For adequate resolution in the phase measurement, the required resolution on the sampling frequency may also be very high to allow coherent sampling. Digital frequency synthesizers could utilize various combinations of phase lock loop stabilized frequency multipliers and frequency dividers to achieve the high resolution needed for coherent sampling, while also generating the slightly offset frequencies for multiple transmitters. A receiver amplifier with high gain and good phase stability is needed. In one embodiment, amplification of about 40 dB of gain is used. In some embodiments, the receiver amplifier may employ two or more gain stages, for example, 20 dB on the antenna and an additional 20 dB on the analog-to-digital conversion board.

[0122] Analog-to-digital converters can also be included on the same printed circuit boards with the emitter and receiver antennas, along with any amplifiers that are appropriate to amplify the signals to an optimum level.

[0123] Data can be transferred from the helmet to the console with various high-speed cable connections and protocols. Using metal cables can induce a source of error by

changing the shape of the magnetic field. To avoid this problem, fiber-optic cables can be used as an alternative to metal cables.

[0124] Data can be transmitted wirelessly from the patient headset or helmet to a console with a wireless protocol such as Bluetooth, WiFi, wireless, or other suitable protocol. The data transmitted can be time domain data, or an FFT can be performed by a processor in the headpiece, and the resulting digital data may then be sent wirelessly to the console. The primary advantage to sending the data in the frequency domain with an FFT is a reduction in the amount of data, resulting in a lower required data transmission rate. The FFT may be performed by a processing element, such as a field-programmable gate array (FPGA) hardwired to perform FFT inside the helmet. Alternatively, other types of microprocessors, including general-purpose microprocessors, could be used to perform the FFT. Because all of these electronics are mounted inside the helmet or other headpiece **129**, in some embodiments, it may be advantageous to minimize the size and power consumption of the components. To further reduce the need for an electrical cable connection to the console, a portable rechargeable battery based power system may be included in the helmet.

[0125] In one embodiment, the system is designed to take multiple samples per second, either continuously or in short bursts, so that the data may be analyzed to measure a patient’s heart rate, or provide other useful information. This technique may help to differentiate arterial from venous blood volume measurements, much like the technique used in pulse oximetry. In another embodiment, the system may be configured to synchronize to an EKG, pulse oximetry, or other cardiac signal. This may provide a very accurate timing trigger for measuring the arterial and venous blood volume simultaneously with a particular portion of the cardiac cycle. Synchronizing VIPS readings to an external cardiac signal allows under-sampling relative to cardiac rhythm, with VIPS readings which can be spaced seconds apart. By comparing VIPS readings at different portions of the cardiac cycle, a series of VIPS readings can be processed to reconstruct fluid composition changes associated with the cardiac rhythm, revealing a measure of the global perfusion within the brain.

[0126] An illustrative system for synchronizing VIPS readings with the cardiac signal will now be discussed. As should be understood, the embodiment of FIG. 7 may be modified with substantially any type of physiologic sensor for detecting variations in a patient’s body and should not be limited to the cardiac signal specifically discussed. FIG. 7 is a block diagram of a system **700** for detecting and monitoring bodily fluid levels due to or occurring with a cardiac cycle of the patient. The system **700** of FIG. 7 may be substantially similar to the system **100** of FIG. 1. However, in the embodiment of FIG. 7, the system **700** includes a cardiac module **701**, which may include a cardiac cycle sensor **702** and a trigger **704**. The cardiac cycle sensor **702** may be substantially any type of sensor or combination of sensors that detect the electrical activity of a patient’s heart. For example, the cardiac cycle sensor **702** may be configured to detect the polarization and depolarization of cardiac tissue. The cardiac cycle sensor **702** may further be in communication with the processing unit **104**, microcontroller **118**, or other processing element that may transform the various signals into a cardiac waveform or other desired form. In a specific example, the cardiac sensor **702** may be a pressure sensor that detects changes in pressure within a patient’s body to detect characteristics of the cardiac

cycle. In another example, the cardiac sensor 702 may be an acoustic sensor that senses changes in sound to detect characteristics of the cardiac system. The cardiac cycle sensor 702 may be formed integrally with the headpiece 106 or may be a separate component therefrom.

[0127] The trigger 704 may be substantially any type of device that may receive and/or transmit signals. The trigger 704 may be in electrical communication with the cardiac sensor(s) 702 and may be configured to transmit a signal, such as an infrared pulse (open air or optical fiber), a radio frequency pulse, and/or radio frequency digital communication based timing pulse, to the processing unit 104 and/or headset 106.

[0128] Using the system 700 of FIG. 7, a VIPS measurement may be triggered wirelessly or wired by the trigger 704. For example, based on detection of a particular cardiac event (e.g., pulse oximetry) or other cardiac signal, the trigger 704 may indicate to the processing unit 104 to activate a VIPS reading, so that data may be detected and collected at specific portions of the cardiac cycle. In this example, the VIPS detection may be based on a cardiac event. However, in other embodiments, the detection antenna or wiring on the cardiac sensor 702 may be sensitive to VIPS radio transmission frequencies and may be configured to be activated by the VIPS in order to capture the instant of each VIPS data acquisition pulse within the EKG record (an augmentation and/or alternative means of assuring very accurate correlation of VIPS data to cardiac cycle data)

[0129] With each heartbeat, the volume of arterial blood, venous blood, and cerebrospinal fluid in the brain fluctuate, and these changes, as detected by VIPS monitoring, may yield valuable diagnostic information. In one embodiment, the system is designed to take multiple samples per second, either continuously or in short bursts, so that the data may be analyzed to measure a patient's heart rate. In another embodiment, the system may be configured to be triggered by and synchronized to an EKG, pulse oximetry, or other cardiac signal. This may provide a very accurate timing trigger for measuring fluid conditions, including arterial blood volume, venous blood volume, and cerebrospinal fluid volume at one or more particular portions of the cardiac cycle. This technique may help to differentiate arterial from venous blood volume measurements, much like the technique used in pulse oximetry.

[0130] In yet another embodiment, the VIPS measurements are not triggered to synchronize to an EKG or other external cardiac signal, but are time tagged with sufficient precision to assign each VIPS measurement to the portion of the cardiac cycle under which it was collected. By comparing VIPS readings at different portions of the cardiac cycle, either by synchronous acquisition or by subsequent analysis, a series of VIPS readings can be processed to reconstruct fluid composition changes associated with the cardiac cycle. Such analysis of VIPS measurements may reveal a measure of the global perfusion within the brain, as well as valuable information for the diagnosis of conditions, such as shunt failure (detailed later in the specification). These methods (synchronizing VIPS readings to an external cardiac signal or time-based correlation with an external cardiac signal) allow under-sampling relative to cardiac rhythm, so that individual VIPS readings may be spaced even many seconds apart, while still providing valuable information relating to fluid fluctuations associated with the cardiac cycle. Other examples include

synchronizing (or isolating irregularities) to a ventilation signal, such as a capnography signal.

[0131] A variety of signal processing analysis techniques, including frequency domain approaches, such as discrete Fourier transforms (DFT) and Fast Fourier Transforms (FFT) analysis, may be applied to the VIPS measurements to reveal the frequency distribution of the oscillations in cerebral fluids, which derive from the patient's heart rate. These techniques may be applied to the measured VIPS phases and/or magnitude data for multiple radio frequencies, either alone or in combination. Useful combinations for analysis include theoretically and empirically derived formulae that use weighted combinations of VIPS phases and amplitude data to create indicators that correlate with blood volume, cerebrospinal fluids, edema, or other relevant fluid characteristics. When an external cardiac signal is available for correlation, the period and frequency of the cardiac cycle is provided and may be used with processing approaches, such as applying averages, medians, or other statistics to VIPS measurements at each of the measured portions of the cardiac cycle, then calculating the differences between bins to determine the magnitudes of the fluid changes associated with the cardiac cycle.

[0132] In another embodiment, the system is designed to take multiple samples per second and is configured to generate a signal that corresponds to the magnitude of the change in intracranial blood volume that results from each arterial pulse. It is well known in the art of intracranial pressure (ICP) measurement that ICP increases during the diastole phase of the cardiac cycle, and decreases during systole, because of the induced changes in intracranial blood volume. Using an ICP monitor, therefore, a plethysmogram can be generated, which approximately plots the intracranial blood volume over time as it fluctuates through repeated cardiac cycles.

[0133] The amplitude of ICP changes due to cardiac pulsation is significantly damped in patients who have cranial vents, for example, an intraventricular catheter. This is because the pressure pulses are relieved as fluid moves back and forth through the catheter. The same dampening of the ICP plethysmogram occurs in patients with intraventricular shunts, as are commonly used in patients with chronic hydrocephalus. When the shunt is working normally, cerebrospinal fluid will move back and forth in the shunt catheter, dampening the ICP excursions during cardiac cycles. However, when the shunt is clogged or otherwise malfunctions, the fluid is unable to move during cardiac cycles, and the amplitude of the ICP variation increases. The current invention can be configured to monitor the changes in blood and cerebrospinal fluid volumes that result during cardiac cycles and detect shunt clogs or malfunctions.

[0134] Once a plethysmogram is generated, there are a variety of ways one can use the information to help diagnose the condition of a patient. For example, after the peak of the cardiac pressure/volume pulse, the following portion of the waveform represents the recovery period during which the fluid volume returns to baseline. The time it takes from the peak to another subsequent point in the cardiac cycle can provide information about intracranial compliance or intracranial pressure. It can help identify specific characteristics of intraventricular shunt performance or failure. Ratios, differences and other mathematical relationships of amplitudes of the plethysmogram at various time points along the cardiac cycle can be developed to indicate a variety of clinical conditions and physiologic parameters.

[0135] There is a need during administration of cardiopulmonary resuscitation (CPR) for providing feedback on the effectiveness of cardiac compressions. Currently, there are devices which can measure displacement distance, which is correlated to cardiac compression and induced blood volume changes. However, these devices do not directly measure the effectiveness of the compressions at inducing blood flow to the brain, which is the primary goal of CPR. The present invention can be applied to the head of a patient undergoing CPR, and direct readings can be made to detect the amplitude of the change in blood volume in the brain during CPR. In this embodiment of the present invention, the effectiveness of CPR can be monitored and improved by providing direct feedback to the CPR administrator as to the actual change in blood volume with each cardiac compression.

[0136] In addition to using the VIPS technology to produce a plethysmogram of intracranial fluid changes, the present invention also can be implemented using other technologies. For example, a plethysmogram can be generated using near-infrared spectroscopy (nirs), or by measuring the absorption of light at a variety of wavelengths. By way of example, pulse oximetry devices typically use two wavelengths of light and rapidly sample the absorption of those wavelengths during cardiac pulsations, creating a plethysmogram. This can also be accomplished with one wavelength. This type of light absorption technology can be applied to the brain, yielding a plethysmogram that can be used to evaluate shunt malfunction. One skilled in the art of plethysmography will recognize that a plethysmogram of the intracranial fluid can be created by a variety of technologies, and the present invention is not limited to any particular technical means of producing the plethysmogram.

[0137] In the art of ICP monitoring, skilled neurologists and other experts can examine the shape of the ICP plots and identify important clinical conditions. With a high sample rate, the plethysmogram produced by the present invention can produce a similar curve and can provide clinical practitioners with similar diagnostic information without the need for an invasive ICP probe. Information about arterial and venous blood flow and volume, intracranial compliance, edema, CSF volume and pulsation, can all be derived from a high resolution plethysmogram. In some cases, it may be useful to combine the VIPS plethysmogram with ICP monitors to better understand the patient's clinical condition, especially when information about multiple distinct fluids is needed. This technique can also be used to inform the clinician about intracranial compliance.

[0138] In another embodiment, detection of intracranial compliance can be accomplished by examining the changes in the volume of one or more intracranial fluids over time, or in response to an external stimulus, such as a valsalva maneuver, jugular vein compression, cerebrospinal fluid injection or withdrawal (as with a spinal tap), hyperventilation, hypoventilation, or change in patient position. The recovery after the initial stimulus can also be an indication of intracranial compliance and autoregulation. The present invention can be used in combination with an ICP monitor to establish the relationship between pressure and volume, and therefore provide information about intracranial fluid compliance and autoregulation. The present device could be combined with other monitoring technologies, such as, but not limited to, ECG, EEG, pulse oximetry, ultrasound, transcranial Doppler, and/or infrared Spectroscopy, to spectroscopy to correlate

intracranial fluid volume to other physiologic parameters that may be useful in diagnosing, managing or treating disease.

[0139] In another embodiment, the current device can be used to detect CSF leaks. For example, a patient who is at risk for a CSF leak, such as a patient undergoing a procedure with epidural anesthesia, could be monitored with the current device, and the device could alert the treating physician when there is a change in the volume of CSF. Since there is currently no way to directly detect CSF leaks during or following spinal or epidural anesthesia, the anesthesiologist will typically leave before the symptoms of the leaks become manifest, hours or days later. Because most patients are still in a recumbent position during immediate post-operative recovery, they generally will not experience any neurological symptoms until well after the surgery, when they stand up. Because of the depletion of CSF inside the skull, the brain will sag due to gravity and the absence of the normal buoyant force supplied by an adequate amount of CSF. It is commonly hypothesized that this sagging induces stress on some of the vessels supplying the brain, resulting in a severe headache, commonly known as a "spinal headache". One common treatment for this type of CSF leak, which is the result of an inadvertent dural puncture, is to inject the patient's autologous blood into the epidural space, near the puncture. This is called a blood patch. Other treatments involve injection of saline or other fluids into the space, or surgical repair of the dural tear. With the appropriate application of the current device, a novel method for treating patients can be formulated, comprising the following steps: applying an intracranial fluid monitor to a patient undergoing a procedure which may result in a CSF leak, detecting the CSF leak, and repairing the leak during the same operative session. Variations on this method could include detecting a CSF leak in a patient using an intracranial fluid monitor, and repairing the leak as a result of the leak detection. Or, a measurement of the intracranial CSF volume of a patient can be made prior to a procedure that may cause a CSF leak, and a second measurement of the intracranial CSF volume can be made during or after the procedure, and if a significant reduction has been detected, the repair can be made before the conclusion of the procedure. Alternatively, the second measurement can be made at any time after the procedure, and a repair can be made after the detection of the leak.

[0140] In another embodiment of the current invention, plethysmography is used to detect respiratory rate and volume, heart rate, or penile erectile function. For instance, sensors could be designed so that they would adhere to the torso in such a way as to detect the extent of thoracic excursion due to the breath cycle. Sensors could also be integrated into an arm band, ear phones, or a watch bracelet to monitor changes in blood volume of the underlying tissue that would then be related via mathematical transformations to the cardiac and respiratory cycles. Sensors adherent to the base of the penis could measure volumetric changes associated with erectile response.

[0141] The console of the VIPS system, according to one embodiment, may include a custom electronic device with a display. A laptop computer or tablet, such as an iPad, could alternatively be used. Using one of these off-the-shelf computers has the advantage of having already integrated wireless communications capability, including Bluetooth or WiFi. But custom consoles comprised of off-the-shelf or custom components can also be used.

[0142] In order to detect an asymmetry (or other symmetrical or non-symmetrical characteristics) of the fluids in the brain, multiple transmitters and receivers can be strategically located. The transmitters and receivers may be located such that the transmitters transmit through different portions of the bulk tissue of the patient and the receivers are located generally opposite to the transmitters so as to receive the signals through the tissue. For instance, a single transmitter (or receiver) could be located on or near the forehead of the patient, and two receivers (or transmitters) are spatially separated from one another and could be located on either side of the head, preferably toward the back, such that the time varying magnetic field propagates through each hemisphere, or in the case of two transmitters each of the time varying magnetic fields propagates uniquely biased to different sides of the brain. In this example, the magnetic fields received by the receivers (or in instances where two transmitters are used, the two magnetic fields received by the single transmitter) will be transmitted substantially through different portions (e.g., a first portion and a second portion) of the overall tissue sample. Depending on the orientation of the transmitter/receiver, there may be some overlap in the tissue portions, but generally the transmitters are arranged to be transmitted through discrete sections of the overall bulk tissue.

[0143] Continuing with this example, uneven signals between the two receivers and one transmitter, or one receiver and two transmitters, could be an indication that a stroke or hemorrhage was present on one side. This is useful, because most brain lesions are not directly in the center of the brain. So, detecting an asymmetry would be an indication of a lesion. To identify the signals sent from each of the transmitters, the signals may include a transmission characteristic as an identifier, such as a synchronization pulse, amplitude or frequency modulation, and or each transmitter could transmit at different fundamental frequencies or a different series of frequencies. For example, the signal sent from the first transmitter may have a different frequency from the signal sent from the second transmitter. As another example, the signal sent from the first transmitter may be shifted in time as compared to the signal sent from the second transmitter. As yet another example, each or one of the signals may include a bit of data (e.g., an amplitude value, or the like) that corresponds to the particular transmitter from which it was transmitted.

[0144] It is possible to allow a single antenna or coil to act as either a transmitter or receiver at different times, thus creating a transceiver. A switch could be implemented, to switch the antenna from being a receiver to being a transmitter and vice versa. For example, the use of a gallium arsenide FET or PIN diode switch could be used. Alternatively, two concentric loop antennas could be located on the same printed circuit board or other substrate.

[0145] In measuring phase shift, some of the electronic components can be sensitive to temperature changes. To minimize the effect of temperature-induced variation, it may be desirable to design the cable from the transmitter to the analog-to-digital converter to be the same length as the cable from the receiver. The addition of compensating electrical resistance or reactance in the form of series/parallel networks of resistors, capacitors, and inductors can also minimize the effect of temperature. Furthermore, heaters or thermo-electro-coolers and thermal insulation may be used to temperature stabilize amplifiers or other components that are inherently temperature sensitive.

[0146] To reduce the effect of the mismatch of the transmit antennae to the cable that delivers the RF transmit signal, a directional coupler may be used to remove cable reflections and provide a pure sample of the transmit signal that may be utilized for analog-to-digital conversion.

[0147] To reduce the sensitivity of the system to movement of people or other objects near the antennae or in the magnetic field, shielding of the antennae to direct the magnetic field may be useful. Various field shaping passive devices formed from ferrites, other magnetic materials, or electrical conductors may be incorporated with the antennae to best match the field profile to the human brain cavity.

Algorithms

[0148] As has been described, the VIPS device may capture electrical property data at a multitude of frequencies. This data may include measurements of the phase shift and attenuation of voltage or current signals between the emitter and detector. In some embodiments, there will be measurements of phase shift or attenuation between multiple emitters and detectors.

[0149] Different biological tissues have varying electrical properties and thus induce different phase shifts and attenuations. By examining the frequency response of the electrical property changes—e.g., phase shift—it is possible to examine volume changes of each of the types of fluid separately. Because the skull is a rigid and closed volume, changes to the volumes of different fluids, such as blood, intracellular fluid, extracellular fluid, and cerebrospinal fluid, affect each other, since the total fluid volume must remain essentially constant. The fundamental relationship between intracranial pressure and intracranial fluid volume was first published over two centuries ago by Professors Monro and Kellie. Monro and Kellie established the doctrine that, because the skull is essentially a rigid, closed volume, venous flow of blood out of the cranium is necessary to allow arterial blood flow into the cranium. This phenomenon also applies to other intracranial fluids.

[0150] A variety of algorithms can be generated to reliably detect changes to the intracranial fluids. Formulas may be derived from the phase shift, attenuation or other electrical parameters at certain frequencies for certain fluids. One formula, $B(p(f_1), a(f_2))$, may be empirically derived which is strongly correlated with intracranial blood volume. In the present example, the formula B , is a function of phase shift (p) at a particular frequency (f_1) and attenuation (a) at the same or another frequency f_2 . In live patients or animals, as blood volume increases, we would expect the volume of cerebrospinal fluid to decrease. Therefore, if we derive a formula for cerebrospinal fluid and call it C , then, a rise in the ratio of B/C may be a good indicator of venous blood pooling, or an intracerebral hemorrhage. As another example, it is well known that as cerebral edema develops, the increased intracellular and extracellular fluid volume pushes some of the intracranial blood out of the skull. Therefore, if we derive a formula for cellular fluid, and call it CF , then the ratio CF/B can be used as a metric to quantify edema. Using ratio formulas can be particularly helpful to divide out noise factors that may affect both the numerator and denominator.

[0151] Going further with this general method, one of ordinary skill in the art may develop many such algorithms which take advantage of formulas which correlate strongly with one or more particular intracranial fluids and or location of the fluids in the brain's hemispheres. Relationship between two

or more fluids can be expressed in mathematical formulas which may include ratios, products, sums, differences, or a variety of other mathematical relationships.

[0152] The present invention can be used to diagnose conditions, such as cerebral bleeding or edema. But it can also be used to help control the administration of treatments for some of these conditions. For example, the device could be used for measuring cellular fluid in brain tissue. In a case of dangerous edema, physicians will often administer intravenous drugs like mannitol and hypertonic saline solution to draw water out of the brain. If not administered properly and in the right dose, these drugs can be dangerous. For the treating physician, it would be useful to know how much fluid was removed from the brain tissue. Therefore the use of a device such as the one described here would have utility as a means for providing feedback for treatments to reduce intracranial fluid volume. Another example would be to use such a device to provide a measure of intracranial blood volume as feedback for administering drugs that alter blood pressure and flow rate, that are sometimes used to treat patients with brain injury. Other examples where intracranial fluid measurements could be used as feedback include: hydration during intense exercise such as running marathons; sodium concentration during intense exercise; or in treating patients with improper levels of sodium.

[0153] Although the examples used here are focused on intracranial fluids, algorithms and treatment methods using a device that can distinguish different types of fluids can be used in other fields of medicine as well. Algorithms and feedback techniques such as are described above can be used to reliably measure ratios of different types of fluids in other parts of the body. For instance examining the fluid that builds up inside the lung tissue in patients with congestive heart failure can be read as a change in the ratio of lung fluid to blood in the same region. Lymphedema that commonly occurs in the arms of patients after breast cancer surgery can be measured as a ratio of extracellular fluid to blood or muscle tissue volume. Treatments for patients that affect tissue fluid volume, such as compression garments for lymphedema, or diuretics for congestive heart failure patients, can be dosed using feedback as has been described above.

Clinical Applications

[0154] During hemodialysis, blood is withdrawn from a patient's vein, and substances including sodium and urea are filtered out. The blood brain barrier prevents these larger molecules, called osmoles, from leaving the brain quickly. This sets up a concentration gradient that provides osmotic pressure to draw water across the blood brain barrier into the brain, resulting in cerebral edema. In extreme cases, this cerebral edema causes a condition called dialysis disequilibrium syndrome and can be severe enough to cause degradation of brain function, or even permanent brain injury. Partly for this reason, dialysis is performed over a prolonged period of time, typically about 4 hours. It is believed that many patients could undergo a more rapid dialysis protocol, but it is difficult to ascertain which patients could tolerate the faster rate. A new dialysis protocol could be enabled by the VIPS system described herein, by monitoring the intracranial fluids during dialysis. The steps of this method would involve placing a fluid monitor on the patient prior to initiation of dialysis, initiating dialysis at a relatively fast rate, and checking for signs of cerebral edema. As edema progresses, the dialysis

can be slowed in response to the fluid readings, thereby customizing the dialysis rate for each patient based on their ability to tolerate the process.

[0155] For patients with sodium imbalances, the VIPS system described herein may be used to detect changes to the sodium level that may result in conditions such as hypernatremia and hyponatremia. In patients suspected of such conditions, the system may be deployed to detect and diagnose the condition, or to aid the clinician in the treatment of the patient to correct their sodium balance by providing real-time feedback during administration of fluid or drug therapies.

[0156] During heart surgery, there is a risk that not enough blood is getting to the brain. This can be the result of an embolism or of lack of circulation or low blood pressure to the brain. One article that discusses this problem is "Silent Brain Injury After Cardiac Surgery: A Review" by Sun et al, journal of the American College of Cardiology, 2012. A fluid monitor could detect a reduction in the amount of blood in the brain, and it could detect ischemia in the brain tissue. Thus, a new monitoring technique could involve placing a fluid monitor, such as the system described herein, on a patient at the beginning of a cardiac surgery and monitoring the patient during the surgery. In the event that the device detects brain ischemia or a reduction in the blood volume in the brain, the physician may be alerted and may attempt to correct the problem through a variety of clinical means.

[0157] A VIPS device can be configured to monitor intracranial pressure noninvasively. It is well known in the field of neurology that intracranial pressure and volume are approximately linearly related when the intracranial fluids are properly regulated by the body's own intracranial fluid control systems. It has been established in clinical studies that a VIPS device can detect fluid shifts that are proportional to pressure changes.

[0158] There is a need for detecting ischemia in the G.I. tract, especially in neonates. The VIPS system described herein may be used to detect ischemia, either with continuous monitoring or with instantaneous measurements.

[0159] Prevention and detection of head injuries in automobile accident victims, football players, in the military, and other types of head injuries is a critical need. Accelerometers have been added to football helmets to monitor accelerations due to impact, and companies like Nike, Inc. have acceleration detectors integrated into caps. But accelerometers are, at best, an indirect way to help determine likelihood of head injury. It is the movement of the brain within the skull in response to the external acceleration forces that lead to concussion or brain injury. VIPS could also be added to helmets, caps, headbands, or applied directly to the head, and could detect the movement of the brain within the skull during the impact. This could be used instead of accelerometers, but would be most effective if used in conjunction with accelerometers. Monitoring brain movement within skull with VIPS would provide a better measure of potential for brain injury than accelerometers alone. Football is one application. Crash testing is another. Research in vehicle safety could benefit greatly from a better understanding of brain movement during impact (e.g., crash testing with cadavers monitored with VIPS).

[0160] Detection of concussion is important, especially in sports injuries. If a person has a concussion, a second concussion before the first has resolved can result in a very severe injury called second impact syndrome. ("second impact syndrome", Bey & Ostick, West J Emerg Med. 2009 February;

10(1): 6-10.) Although the science of concussion and its effect on intracranial fluids is still evolving, VIPS could be used to detect early stages of intracranial swelling, hyperemia, venous pooling, hemorrhage, ischemia, blood flow rate changes or other biologic changes affecting the tissue's bioimpedance. With a VIPS device, readings may be taken prior to a game or at some other baseline time, and readings after a potential injury event may be compared to the baseline to establish the presence or degree of injury.

[0161] A variety of other medical conditions may be monitored with the VIPS system described herein. Peripheral edema can be caused by a variety of medical conditions. Swelling in the feet and legs is common among patients with congestive heart failure. Swelling in the arms is common after breast cancer surgery when patients develop lymphedema. Swelling is common in limbs or other parts of the body after surgery. In some types of surgery, there is a flap of tissue that is at risk for ischemia, edema, or venous pooling. Compartment syndrome can result after an injury when there is insufficient blood flow to muscles and nerves due to increased pressure within the compartment such as an arm, leg, or any enclosed space within the body. Current devices measure compartment syndrome pressure using a minimally invasive device involving a needle to penetrate the tissue and take a reading of the pressure. ("accuracy in the measurement of compartment pressures: a comparison of three commonly used devices"; Boody & Wongworawat, *J Bone Joint Surg Am.* 2005 November; 87(11):2415-22.) Patients with congestive heart failure or other conditions can have a buildup of fluid in their lungs or chest cavity. The VIPS device described herein may be used to monitor changes related to swelling, blood flow, perfusion, and/or other fluid characteristics of limbs and other parts of the body due to any of these or other conditions. A baseline reading may be taken, and subsequent measurements may be compared to that baseline to monitor and detect changes, for example, to swelling or perfusion of the tissue. Continuous monitoring of swelling may provide feedback for medical therapies to control edema, blood flow, or other clinical parameters.

[0162] Dehydration can be a life-threatening medical condition and can occur during athletic activities, such as marathon running, and in patients with a variety of medical conditions. The VIPS device described herein may be used for quantifying the hydration level of a patient for purposes of an initial diagnosis, for monitoring effectiveness of treatment, and/or as an alarm to a worsening condition of a patient.

[0163] Fighter pilots and other people undergoing extreme accelerations can sometimes lose consciousness, as a result of sudden fluid shifts within their brain. Similar conditions can occur in deep sea divers, astronauts, skydivers and mountain climbers who are exposed to extreme conditions that may affect their intracranial fluids. The VIPS device described herein may be installed inside a helmet or otherwise affixed to a person's head during activities that put them at risk for changes to their intracranial fluids could be monitored in real time. If a dangerous change in fluids were to occur, the individual or a third party could be alerted to provide intervention.

[0164] Migraine headaches are well known to be caused by expansion of blood vessels in and around the brain. Regular or continuous monitoring of intracranial blood volume may be used to diagnose or better understand the physiology of migraine. An individual migraine patient may quantify the effect of various migraine treatments during administration, and may use that information as feedback to titrate medica-

tion or otherwise adjust therapy. Regular periodic monitoring by migraine patients, for example brief VIPS spot check readings nightly and upon waking in the morning, would allow individuals to detect characteristic intracranial fluid changes that precede migraine headache symptoms, thus facilitating earlier interventions that more effectively reduce symptoms.

[0165] Penile plethysmography is commonly used in urologic surgery to evaluate erectile function before and after prostate resection. Currently, this is typically accomplished via circumferential strain-gauge transducers. A VIPS sensor could be utilized to provide direct volumetric measurements of penile filling. Such a device could also be used in the ambulatory setting to evaluate the etiology of erectile dysfunction, i.e. whether physiologic or psychogenic, or monitoring night-time arousal.

[0166] As described above, various methods using the systems **100**, **700** to detect bodily fluids (either directly or indirectly) may be used. For example, in one method, asynchronous EKG and VIPS readings may be time-stamped and the VIPS readings may be binned as a function of position in cardiac cycle for subsequent analysis. Exemplary analysis includes, as some examples, statistics such as median or mean values in each bin, then differences between mean values for bins associated with diastolic and systolic portions could indicate the extent of fluid exchange.

[0167] As another example of a method, a signal processing algorithms, e.g. FFT, DFT, may be applied by the processing unit **104** and/or computing device (e.g., laptop, desktop, server) to the measured phases, amplitudes, and/or weighted combinations such as the computed indicators that correlate with blood, CSF, etc. In order to determine heart rate (a frequency) and/or amplitudes of fluid changes associated cardiac cycle.

[0168] Physiologic monitoring is commonly utilized in a variety of medical settings, to include such parameters as heart rate and respiratory rate. While a variety of modalities currently exist to derive these values—electrical, optical, and others—VIPS could also be used to provide data on these vital signs, thereby obviating the need for additional monitors when a VIPS device is already being utilized for cranial fluid surveillance, or as an additional source of the same information. That is, a physiologic sensor can be used to detect, either directly or indirectly, one or more characteristics of fluid flow or other conditions within the patient's body and then these conditions may be used to calibrate or filter the data from the VIPS system.

[0169] Autoregulation of intracranial fluids is a complex biological process, involving vasodilation, vasoconstriction, movement of cerebrospinal fluid (CSF) between various compartments of the brain and the spinal column, and production of CSF. Patients with a variety of neurological disorders can have poor autoregulation, which can lead to elevated or reduced intracranial pressure. The VIPS device described herein may be used to evaluate the autoregulation and intracranial compliance of a particular patient. Tests may be developed to measure the fluid changes that occur as a result of a procedure or posture change. For example, a patient may lie flat on his or her back, and a clinician may take a fluid volume reading, raise the patient's legs into an elevated position, and measure the fluid changes that occur. Other tests may include intravenous infusion of bulk fluids, administration of medications, and/or moving the patient from a flat to vertical position, all of which will induce a change to the blood, CSF

and other fluids in the brain. The results from a particular patient test may be compared against a baseline measurement of the same patient performed at a different time, or against a database of known normal and pathologic responses, helping the clinician to better understand the patient's autoregulation and intracranial compliance status. With a better understanding of a patient's intracranial fluid function, the clinician may be better able to select a course of treatment that is most beneficial to the patient.

[0170] Studies comparing the return to normal cerebrovascular reactivity (CVR) in subjects after voluntary manipulations of the blood flow to the brain show a difference between those with a concussion and healthy subjects. Unlike healthy subjects, those with concussions failed to return to normal CVR after hyperventilation tests. This condition lasted for several days after the concussion. In contrast, in healthy subjects, the CVR returned to normal conditions in a much shorter time. Our experiment shows that bulk measurements of the electromagnetic properties of the brain have measurable changes during tests that affect the CVR, such as the valsalva maneuver and jugular vein compression. The results show that return to both temporal and magnitude normal can be detected precisely with the devices and methods described in this patent application. This illustrates that the devices and methods can be used to detect a variety of diseases, such as concussion, by evaluating the temporal and magnitude patterns of the excursion from a normal signature, due to maneuvers that produce well-controlled voluntary changes in blood flow.

Experimental Example

[0171] This experiment was based on the idea that substantial insight can be found in the electromagnetic signature response to a voluntary change in tissue condition. This could lead to a much more controlled diagnostic method, based on electromagnetic measurements of biological tissue condition. In our experiment, a voluntary change was produced in the interrogated organ or tissue, and the diagnostics were performed by evaluating the changes of electromagnetic properties that occurred in those organs or tissue in response to the voluntary produced change and correlating these changes to the voluntary action.

[0172] One example of the method relates to brain concussion, an important medical problem in sports medicine. Sports induced concussion or mild traumatic brain injury (mTBI) is of increasing concern in sports medicine. Neuropsychological examination is the main diagnostic tool for detecting mTBI. However, mTBI also produces physiological effects that include changes in heart rate and decreases in baroreflex sensitivity, cellular metabolism and cerebral blood flow. Cerebrovascular reactivity (or "cerebrovascular response," CVR), which is a measure of cerebrovascular flow, is impaired by brain trauma. Various methods are used to assess CVR. They include hyperventilation, breath holding, CO₂ inhalation, and administration of acetazolamide. It has been shown that Doppler ultrasound measurements on the carotid artery can be used to monitor changes in CVR, which can then be correlated with mTBI and used for diagnosis of the condition. The methods and devices described herein provide an alternative means for measuring changes in CVR, with a practical application in diagnosis of mTBI.

[0173] This experiment demonstrates that the various methods used to assess CVR through voluntary actions on the body produce changes in the electromagnetic properties of

the brain. These properties produce a distinct signature in magnitude and time and can therefore be used with our device for brain diagnostics.

Experimental System

Inductive Spectrometer

[0174] An experimental multi-frequency inductive spectrometer was designed and constructed. The system consisted of four modules: function generator, transceiver, dual-channel demodulator and analog-digital converter. A personal computer was used to control the system and process the data. The function generator module used two identical programmable synthesizers (NI 5401 synthesizers, National Instruments, Inc., Austin, Tex.) as oscillators. The first oscillator supplied an excitation signal $I\cos(\omega_e t)$ of approximately 20 mA, in the range of 1 to 10 MHz, at pre-programmed steps. A modulation signal $I\cos(\omega_m t)$ was generated by the second oscillator. The difference $\omega_e - \omega_m = \omega_o = 100(2\pi)$ was maintained constant in the whole bandwidth, in order to produce a narrow band measured voltage signal on a constant low intermediate frequency for processing and demodulation.

[0175] The excitation and modulation signals were connected to the transceiver and the dual-channel demodulator modules, respectively. The transceiver consisted of an excitation coil and a sensing coil, coaxially centered at a distance $d=18$ cm and two differential receiver amplifiers AD8130. Both coils were built with magnet wire AWG32 rolled on a cylindrical plastic former with radius $r=2$ cm, five turns. The coil inductance, as calculated from Faraday's law, was approximately 40 mH. The excitation coil generated a primary oscillating magnetic field. The sensing coil detected the primary magnetic field and its perturbation through a proximal conductive sample. To avoid inductive pickup, the leads of the coils were twisted. The amplifiers were connected as conventional operational amplifiers and collected the reference voltage (V_{ref}) and the induced voltage (V_{ind}) in the excitation and sensing coils, respectively. The gain of the amplifiers was adjusted in order to obtain a dynamic range of $\pm 5V$ throughout the whole bandwidth.

[0176] The dual-channel demodulator module used a mixer and a narrow band pass filter to transfer the information of any excitation and sensing frequency to the same low frequency (ω_o). This module used two similar channels for demodulation of the reference and induced signals. To avoid additional inductance and stray capacitance in the circuit, the amplifiers and dual channel-demodulator circuits were shielded by a metallic box and connected to the coils with short coaxial cables (length less than 0.8 m). The current passed through the shield to minimize any inductance mutual between the circuit and the coils.

[0177] The analog-digital conversion module digitized the reference and induced voltage signals on the constant low frequency. A data acquisition card (NI 6071E, National Instruments, Inc., Austin, Tex.), with a sample rate of 1.25 MSamples/seg and a resolution of 12 bits, was used as an analog-digital converter.

[0178] The phase of the reference and induced voltages are calculated in software over approximately five cycles by an extract single tone function available in LABVIEW V6.1 (National Instruments Inc, Austin, Tex.). The phase shift between the reference and induced voltage was estimated as $\Delta\theta = \theta(V_{ref}) - \theta(V_{ind})$. The ratio signal to noise (SNR) for

phase shift measurement was improved by averaging over twenty spectra (39 dB at 1 MHz).

Experimental Protocol

External Jugular Vein Compression

[0179] The two external jugular veins, found on both lateral sides of the neck, are one of the main routes for cerebral venous drainage. By applying light pressure to both sides of the neck, a person can inhibit drainage. In doing so, intracranial fluid volumes increase 20-30 cc. The purpose of this experiment was to evaluate the ability of the phase shift intracranial fluid monitoring device, as described in this patent application, to detect these changes in blood volume.

[0180] The experiment showed that, following release of the jugular vein after compression, there was an exponential decay in reading. It also showed that, following a second compression and release, the reading did not return to the original value. This is typical of CVR when the metabolism is exhausted due to partial ischemia. It suggests that this method can provide another technique for evaluating CVR and thereby assess concussion.

[0181] With reference to FIG. 12, the results of the experience are presented in the graph. As shown in FIG. 2, calibrated phase shift measurements are plotted as a function of time and the increase in phase shift is caused by the vein compression and the decrease during the release. Further, following the blood vessel release there is an exponential decay in reading that does not return to the original value. This is typical of CVR when the metabolism is exhausted due to partial ischemia and indicates that the method can provide another technique for evaluating CVR and assessing concussion.

Valsalva Maneuver

[0182] The Valsalva maneuver is performed by moderately forceful attempted exhalation against a closed airway, usually done by closing ones mouth and pinching ones nose while pressing out, as if blowing up a balloon. The Valsalva maneuver tests the body's ability to compensate for changes in the amount of blood that returns to the heart (preload) and affects the blood flow into and from the head. The dynamic response of the circulation system through the maneuver is indicative of several physiological functions, including the CVR. There are other conditions that can be evaluated with this procedure. For instance, patients with autonomic dysfunction will have changes in heart rate and/or blood pressure that differ from those expected in healthy patients.

[0183] A temporal response to the Valsalva maneuver was measured, using a device as described herein. The measurement had several typical temporal aspects that may be used for diagnostic purposes. These include the time constant of the increase in the reading, the peak value, the time constant of the decays, and the final short term and long term values.

[0184] FIG. 13 illustrates a graph shown the changes in shift reading as a function of time during the Valsalva procedure. As shown in FIG. 13, the reading has several typical temporal aspects that can be used for diagnostics and these include the time constant of the increase in reading, the peak value, the time constant of the decay, as well as the final short term and long term value.

Detecting Concussions

[0185] Return to normal CVR in subjects after voluntary manipulations of the blood flow to the brain is different for those with a concussion than it is for healthy subjects. Subjects with concussions failed to return to normal CVR after hyperventilation tests for several days after the concussion. In healthy subjects, on the other hand, the CVR returned to normal conditions in a much shorter timeframe. Our experiment shows that our bulk measurements of the electromagnetic properties of the brain show measurable changes during tests that affect the CVR, such as the Valsalva maneuver and jugular vein compression. The results show that return to normal can be detected precisely with our measurements. This proves that our device can be used to detect a variety of diseases, such as concussion, by evaluating the temporal and magnitude patterns of the excursion from a normal signature due to maneuvers that produce well-controlled voluntary changes in blood flow.

[0186] Although specific embodiments of the disclosure have been described herein for purposes of illustration, various modifications may be made without deviating from the spirit and scope of the disclosure. For example, although the present application includes several examples of monitoring fluid changes in the human brain as one potential application for the systems and methods described herein, the present disclosure finds broad application in a host of other applications, including monitoring fluid changes in other areas of the human body (e.g., arms, legs, lungs, etc.), in monitoring fluid changes in other animals (e.g., sheep, pigs, cows, etc.), and in other medical diagnostic settings. Fluid changes in an arm, for example, may be detected by having an arm wrapped in a bandage that includes a transmitter and a receiver.

[0187] A few examples of the other medical diagnostic settings in which the systems and methods described herein may be used include determining an absolute proportion of a particular fluid, tissue (e.g., muscle, fat, parenchymal organs, etc.), or other solid matter (e.g., a tumor) in a given area of a human body, determining relative permittivity and/or relative permeability of an object, and so forth. Further clinical applications include a wide variety of monitoring and diagnostic uses, including internal bleeding detection, distinction between different types of fluid (e.g. blood, extracellular fluid, intracellular fluid, etc.), assessing edema including cerebral edema as well as lymphedema, and assessing lung fluid build-up resulting from such conditions as congestive heart failure. All of these applications and many more may be addressed by various embodiments described herein. Accordingly, the scope of the claims is not limited to the specific examples given herein.

We claim:

1. A device for detecting spatial differences in fluid level changes in a tissue of a patient, the device comprising:
 - a support structure for securing the device to a body part of the patient;
 - a processing element operably connected to the support structure;
 - a wireless networking interface operably connected to the support structure and in communication with the processing element and an external computing device via a wireless network;
 - a first transmission module operably connected to the support structure and in communication with the processing element;

- a second transmission module operably connected to the support structure and in communication with the processing element; and
- a third transmission module operably connected to the support structure and in communication with the processing element,
- wherein the first transmission module is opposed to the second and third transmission modules and when activated transmits a first time varying magnetic field through the tissue of the patient,
- wherein the second transmission module and the third transmission module are spatially separated from one another relative to the tissue of the patient and receive first and second versions of the first magnetic field transmitted by the first transmission module and transmit a first received magnetic field data to the processing element, and
- wherein the processing element provides transmission data corresponding to the first received magnetic field data to the wireless networking interface, which in turn transmits the transmission data wirelessly to the external computing device.
2. The device of claim 1, wherein the processing element is configured to convert the first received magnetic field data to a digital form before transmitting the transmission data to the networking interface.
3. The device of claim 1, wherein the support structure comprises a headset, including first and second arms extending parallel to one another and configured to be positioned on opposite sides of a patient's head.
4. The device of claim 3, wherein the headset comprises glasses frames.
5. The device of claim 1, wherein the support structure is wearable by the patient.
6. The device of claim 1, wherein the processing element translates the first and second versions of the first received magnetic field by a Fast Fourier Transform to convert the first received magnetic field into the transmission data.
7. The device of claim 1, wherein the second transmission module and the third transmission module transmit a second time varying magnetic field and a third time varying magnetic field, respectively, through the tissue of the patient, and wherein the first transmission module is configured to receive the second and third time varying magnetic fields.
8. A method for detecting symmetry in fluid levels in a tissue of a patient, the method comprising:
- securing a device, including a receiver, a first transmitter, and a second transmitter, on the patient's head, such that the first transmitter and the second transmitter are spatially separated from one another, and the receiver is in communication with the first transmitter and the second transmitter via a transmission pathway through the tissue;
 - transmitting a first time varying magnetic field from the first transmitter;
 - transmitting a second time varying magnetic field from the second transmitter;
 - receiving a first received field and a second received field with the receiver;
 - analyzing at least one transmission characteristic with a processing element;
 - determining, by the processing element, that the first received field corresponds to the first time varying magnetic field and the second received field corresponds to the second time varying magnetic field;
 - determining, by the processing element, a first phase shift between the first time varying magnetic field and the first received field;
 - determining, by the processing element, a second phase shift between the second time varying magnetic field and the second received field; and
 - determining, by the processing element, a change in fluid in the tissue over a period of time based on the determined first and second phase shifts.
9. The method of claim 8, wherein analyzing at least one transmission characteristic comprises analyzing a difference in time or frequency or attenuation between the first time varying magnetic field and the second time varying magnetic field.
10. The method of claim 8, wherein the first received field passes substantially through a first part of the bulk tissue to the second received field passes substantially through a second part of the bulk tissue.
11. The method of claim 8, wherein the device comprises a third transmitter, and wherein the method further comprises:
- transmitting a third time varying magnetic field from the third transmitter;
 - receiving a third received field with the receiver;
 - determining, with the processing element, that the third received field corresponds to the third time varying magnetic field;
 - determining, by the processing element, a third phase shift between the third time varying magnetic field and the third received field; and
 - determining, by the processing element, the change in fluid in the tissue over the period of time based on the first, second, and third phase shifts.
12. The method of claim 11, wherein the first transmitter, the second transmitter, the third transmitter, and the receiver are positioned at spatially discrete locations relative to the tissue.
13. The method of claim 8, wherein the processing element is attached to the device.
14. The method of claim 8, wherein the processing element is part of an external computing device, and wherein the method further comprises transmitting data from the device to the processing element of the external computing device corresponding to the first phase shift and the second phase shift, wherein the processing element of the external computing device determines the change in the fluid.
15. The method of claim 14, wherein transmitting the data to the external computing device comprises transmitting data via a network.
16. The method of claim 8, further comprising:
- receiving, by the processing element, a physiologic sensor signal; and
 - analyzing the first phase shift and the second phase shift against the physiologic sensor.
17. The method of claim 16, wherein the physiologic sensor is a cardiac sensor.
18. A method for detecting variations in fluid levels in a patient, the method comprising:
- attaching a headset to the patient, the headset comprising:
 - a support band for securing the headset to the head of a patient;

a processing element coupled to the support band and configured to transfer data wirelessly to an external computer; and
multiple transmitter/receiver components operably connected to the support band at discrete locations;
activating the headset to take one or more fluid level readings within the head of the patient;
wirelessly transmitting fluid data corresponding to the one or more fluid level readings from the processing element to the external computer; and
analyzing the fluid data with the external computer.

19. The method of claim **18**, wherein the fluid data comprises data corresponding to multiple phase shifts detected by the multiple transmitter/receiver components.

20. The method of claim **18**, wherein analyzing the fluid data over a period of time comprises determining a change in the fluid levels in the patient based on multiple phase shifts.

21. The method of claim **18**, wherein the multiple transmitter/receiver devices comprise at least three transmitter/receiver components, and wherein activating the headset

causes the at least three transmitter/receiver components to transmit at least three time varying magnetic fields through the head of the patient.

22. The method of claim **18**, wherein at least three time varying magnetic fields are transmitted with at least one of different frequencies or sequenced times.

23. The method of claim **18**, further comprising:
receiving electrocardiogram data with the external computer; and
comparing the fluid data with the electrocardiogram data, using the external computer.

24. The method of claim **18**, further comprising using the comparison of the fluid data with the electrocardiogram data to calibrate the fluid data.

25. The method of claim **18**, further comprising processing the one or more fluid level readings, using the processing element, to generate the fluid data.

26. The method of claim **18**, wherein the discrete locations of the transmitter/receiver components are selected to allow detection of asymmetric injuries in the patient.

* * * * *

专利名称(译)	使用磁信号检测和分析空间变化的液位		
公开(公告)号	US20150374292A1	公开(公告)日	2015-12-31
申请号	US14/844681	申请日	2015-09-03
申请(专利权)人(译)	CEREBROTECH医疗系统, INC.		
当前申请(专利权)人(译)	CEREBROTECH医疗系统, INC.		
[标]发明人	WYETH RICHARD WARREN LEVINSON MITCHELL ELLIOTT WEBER BRYAN JON SHUSTERMAN EUGENE MARK RUBINSKY BORIS		
发明人	WYETH, RICHARD WARREN LEVINSON, MITCHELL ELLIOTT WEBER, BRYAN JON SHUSTERMAN, EUGENE MARK RUBINSKY, BORIS		
IPC分类号	A61B5/00 A61B5/0452 A61B5/03 A61B5/04		
CPC分类号	A61B5/721 G16H50/30 A61B5/0042 A61B5/05 A61B5/4064 A61B5/4839 A61B5/4848 A61B5/4878 A61B5/6814 A61B5/7225 A61B5/7275 A61B2562/166 A61B2562/182 A61B2562/222 A61B2576/026 A61B5/7257 A61B5/4875 A61B5/0022 A61B5/6803 A61B5/031 A61B2562/0223 A61B2560/0223 A61B5/04008 A61B5/0013 A61B5/7214 A61B5/0522 A61B6/032 A61B5/7282 G16H40/67 G16H50/20		
优先权	61/588516 2012-01-19 US 62/131882 2015-03-12 US 62/048690 2014-09-10 US 62/045044 2014-09-03 US		
外部链接	Espacenet USPTO		

摘要(译)

一种用于检测患者组织中的液位变化的空间差异的装置可以包括：用于将装置固定到患者的身体部分的支撑结构；可操作地连接到支撑结构的处理元件；无线网络接口，可操作地连接到所述支撑结构并且经由网络与所述处理元件和外部计算设备通信；第一传输模块，可操作地连接到所述支撑结构并与所述处理元件通信；第二传输模块和第三传输模块，可操作地连接到所述处理元件支撑结构并与处理元件通信。当被激活时，第一传输模块传输第一时变磁场通过患者的组织。第二和第三传输模块在空间上彼此分离，分别接收第一时变磁场的第二和第三版本。

