



US009782110B2

(12) **United States Patent**
Kiani

(10) **Patent No.:** **US 9,782,110 B2**
(45) **Date of Patent:** ***Oct. 10, 2017**

(54) **OPTICOUSTIC SENSOR**
(71) Applicant: **Masimo Corporation**, Irvine, CA (US)
(72) Inventor: **Massi Joe E. Kiani**, Laguna Niguel, CA (US)
(73) Assignee: **Masimo Corporation**, Irvine, CA (US)
(*) Notice: Subject to any disclaimer, the term of this patent is extended or adjusted under 35 U.S.C. 154(b) by 0 days.

This patent is subject to a terminal disclaimer.

(56) **References Cited**

U.S. PATENT DOCUMENTS
3,682,161 A 8/1972 Alibert
3,951,230 A 4/1976 Littmann
(Continued)

FOREIGN PATENT DOCUMENTS
CA 2490438 1/2004
CA 2262236 4/2008
(Continued)

OTHER PUBLICATIONS

(21) Appl. No.: **14/928,484**
(22) Filed: **Oct. 30, 2015**
(65) **Prior Publication Data**
US 2016/0045118 A1 Feb. 18, 2016

US 8,740,816, 06/2014, Telfort et al. (withdrawn)
(Continued)

Primary Examiner — Eric Winakur
(74) *Attorney, Agent, or Firm* — Knobbe Martens Olson & Bear, LLP

Related U.S. Application Data
(63) Continuation of application No. 13/152,259, filed on Jun. 2, 2011, now Pat. No. 9,326,712.
(Continued)

(57) **ABSTRACT**

(51) **Int. Cl.**
A61B 5/1455 (2006.01)
A61B 8/02 (2006.01)
(Continued)
(52) **U.S. Cl.**
CPC **A61B 5/1455** (2013.01); **A61B 5/0205** (2013.01); **A61B 5/0261** (2013.01);
(Continued)
(58) **Field of Classification Search**
CPC A61B 5/1455; A61B 5/14551; A61B 5/14552; A61B 5/7435; A61B 5/6823;
(Continued)

A physiological sensor has an optic assembly, an acoustic assembly and an attachment assembly. The optic assembly has an optic transducer that is activated so as to transmit a plurality of wavelengths of light into a tissue site and to detect the light after attenuation by pulsatile blood flow within the tissue site. The acoustic assembly has an acoustic transducer activated so as to respond to vibrations at the surface of the tissue site. The attachment assembly affixes the optic assembly and acoustic assembly to the tissue site, such as along one side of a person's neck or the forehead. A sensor cable extends from the attachment assembly so as to transmit an optic transducer signal and an acoustic transducer signal to a monitor for calculation of physiological parameters.

12 Claims, 11 Drawing Sheets

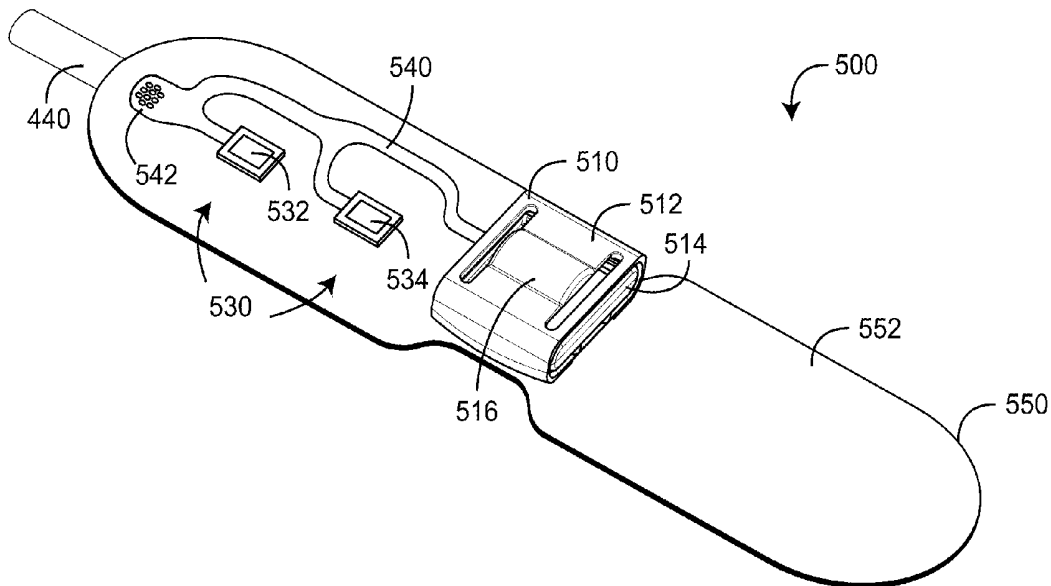

Related U.S. Application Data					
		D363,120	S	10/1995	Savage et al.
		5,456,252	A	10/1995	Vari et al.
		5,479,934	A	1/1996	Imran
(60)	Provisional application No. 61/350,673, filed on Jun. 2, 2010.	5,482,036	A	1/1996	Diab et al.
		5,490,505	A	2/1996	Diab et al.
		5,494,043	A	2/1996	O'Sullivan et al.
(51)	Int. Cl.	5,533,511	A	7/1996	Kaspari et al.
	<i>A61B 8/06</i> (2006.01)	5,534,851	A	7/1996	Russek
	<i>A61B 5/00</i> (2006.01)	5,539,831	A	7/1996	Harley
	<i>A61B 5/0205</i> (2006.01)	5,561,275	A	10/1996	Savage et al.
	<i>A61B 5/08</i> (2006.01)	5,562,002	A	10/1996	Lalin
	<i>A61B 5/026</i> (2006.01)	5,564,108	A	10/1996	Hunsaker et al.
	<i>A61B 5/024</i> (2006.01)	5,578,799	A	11/1996	Callahan et al.
		5,590,649	A	1/1997	Caro et al.
(52)	U.S. Cl.	5,602,924	A	2/1997	Durand et al.
	CPC <i>A61B 5/02427</i> (2013.01); <i>A61B 5/08</i> (2013.01); <i>A61B 5/0816</i> (2013.01); <i>A61B 5/14552</i> (2013.01); <i>A61B 5/6814</i> (2013.01); <i>A61B 5/6815</i> (2013.01); <i>A61B 5/6822</i> (2013.01); <i>A61B 5/6823</i> (2013.01); <i>A61B 5/6832</i> (2013.01); <i>A61B 8/06</i> (2013.01)	5,632,272	A	5/1997	Diab et al.
		5,638,816	A	6/1997	Kiani-Azarbayjany et al.
		5,638,818	A	6/1997	Diab et al.
		5,645,440	A	7/1997	Tobler et al.
		5,685,299	A	11/1997	Diab et al.
		5,730,140	A	3/1998	Fitch
		D393,830	S	4/1998	Tobler et al.
		5,738,106	A	4/1998	Yamamori et al.
(58)	Field of Classification Search	5,743,262	A	4/1998	Lepper, Jr. et al.
	CPC <i>A61B 5/6832</i> ; <i>A61B 5/7475</i> ; <i>A61B 5/029</i> ; <i>A61B 5/0205</i> ; <i>A61B 5/6822</i> ; <i>A61B 5/0816</i> ; <i>A61B 8/00</i> ; <i>A61B 8/06</i>	5,758,644	A	6/1998	Diab et al.
	See application file for complete search history.	5,760,910	A	6/1998	Lepper, Jr. et al.
		5,769,785	A	6/1998	Diab et al.
		5,782,757	A	7/1998	Diab et al.
		5,785,659	A	7/1998	Caro et al.
		5,791,347	A	8/1998	Flaherty et al.
(56)	References Cited	5,810,734	A	9/1998	Caro et al.
	U.S. PATENT DOCUMENTS	5,812,678	A	9/1998	Scalise et al.
		5,823,950	A	10/1998	Diab et al.
		5,825,895	A	10/1998	Grasfield et al.
		5,830,131	A	11/1998	Caro et al.
		5,833,618	A	11/1998	Caro et al.
		5,860,919	A	1/1999	Kiani-Azarbayjany et al.
		5,890,929	A	4/1999	Mills et al.
		5,904,654	A	5/1999	Wohltmann et al.
		5,912,656	A	6/1999	Tham et al.
		5,919,134	A	7/1999	Diab
		5,934,925	A	8/1999	Tobler et al.
		5,940,182	A	8/1999	Lepper, Jr. et al.
		5,977,538	A	11/1999	Unger et al.
		5,989,193	A	11/1999	Sullivan
		5,995,855	A	11/1999	Kiani et al.
		5,997,343	A	12/1999	Mills et al.
		6,002,952	A	12/1999	Diab et al.
		6,011,986	A	1/2000	Diab et al.
		6,027,452	A	2/2000	Flaherty et al.
		6,036,642	A	3/2000	Diab et al.
		6,045,509	A	4/2000	Caro et al.
		6,048,323	A	4/2000	Hon
		6,067,462	A	5/2000	Diab et al.
		6,081,735	A	6/2000	Diab et al.
		6,083,156	A	7/2000	Lisiecki
		6,088,607	A	7/2000	Diab et al.
		6,106,481	A	8/2000	Cohen
		6,110,522	A	8/2000	Lepper, Jr. et al.
		6,124,597	A	9/2000	Shehada
		6,128,521	A	10/2000	Marro et al.
		6,129,675	A	10/2000	Jay
		6,144,868	A	11/2000	Parker
		6,151,516	A	11/2000	Kiani-Azarbayjany et al.
		6,152,754	A	11/2000	Gerhardt et al.
		6,157,850	A	12/2000	Diab et al.
		6,165,005	A	12/2000	Mills et al.
		6,168,568	B1	1/2001	Gavriely
		6,184,521	B1	2/2001	Coffin, IV et al.
		6,206,830	B1	3/2001	Diab et al.
		6,210,344	B1	4/2001	Perin et al.
		6,229,856	B1	5/2001	Diab et al.
		6,232,609	B1	5/2001	Snyder et al.
		6,236,872	B1	5/2001	Diab et al.
		6,241,683	B1	6/2001	Macklem et al.
		6,248,083	B1	6/2001	Smith et al.
		6,253,097	B1	6/2001	Aronow et al.
		6,256,523	B1	7/2001	Diab et al.
		6,261,237	B1	7/2001	Swanson et al.

(56)

References Cited

U.S. PATENT DOCUMENTS

6,263,222	B1	7/2001	Diab et al.	6,816,744	B2	11/2004	Garfield et al.
6,271,760	B1	8/2001	Watanabe et al.	6,822,564	B2	11/2004	Al-Ali
6,275,594	B1	8/2001	Senoo et al.	6,826,419	B2	11/2004	Diab et al.
6,278,522	B1	8/2001	Lepper, Jr. et al.	6,830,711	B2	12/2004	Mills et al.
6,280,213	B1	8/2001	Tobler et al.	6,850,787	B2	2/2005	Weber et al.
6,285,896	B1	9/2001	Tobler et al.	6,850,788	B2	2/2005	Al-Ali
6,295,365	B1	9/2001	Ota	6,852,083	B2	2/2005	Caro et al.
6,301,493	B1	10/2001	Marro et al.	6,861,639	B2	3/2005	Al-Ali
6,317,627	B1	11/2001	Ennen et al.	6,898,452	B2	5/2005	Al-Ali et al.
6,321,100	B1	11/2001	Parker	6,920,345	B2	7/2005	Al-Ali et al.
6,325,761	B1	12/2001	Jay	6,931,268	B1	8/2005	Kiani-Azarbayjany et al.
6,334,065	B1	12/2001	Al-Ali et al.	6,934,570	B2	8/2005	Kiani et al.
6,343,224	B1	1/2002	Parker	6,937,736	B2	8/2005	Toda
6,349,228	B1	2/2002	Kiani et al.	6,939,305	B2	9/2005	Flaherty et al.
6,360,114	B1	3/2002	Diab et al.	6,943,348	B1	9/2005	Coffin, IV
6,368,283	B1	4/2002	Xu et al.	6,950,687	B2	9/2005	Al-Ali
6,371,921	B1	4/2002	Caro et al.	6,954,971	B1	10/2005	Bryant et al.
6,377,829	B1	4/2002	Al-Ali	6,961,598	B2	11/2005	Diab
6,388,240	B2	5/2002	Schulz et al.	6,970,792	B1	11/2005	Diab
6,397,091	B2	5/2002	Diab et al.	6,979,812	B2	12/2005	Al-Ali
6,415,033	B1	7/2002	Halleck et al.	6,985,764	B2	1/2006	Mason et al.
6,423,013	B1	7/2002	Bakker et al.	6,993,371	B2	1/2006	Kiani et al.
6,430,437	B1	8/2002	Marro	6,996,427	B2	2/2006	Ali et al.
6,430,525	B1	8/2002	Weber et al.	6,999,904	B2	2/2006	Weber et al.
6,438,238	B1	8/2002	Callahan	7,003,338	B2	2/2006	Weber et al.
6,463,311	B1	10/2002	Diab	7,003,339	B2	2/2006	Diab et al.
6,470,199	B1	10/2002	Kopotic et al.	7,015,451	B2	3/2006	Dalke et al.
6,486,588	B2	11/2002	Doron et al.	7,020,508	B2	3/2006	Stivoric et al.
6,501,975	B2	12/2002	Diab et al.	7,024,233	B2	4/2006	Ali et al.
6,505,059	B1	1/2003	Kollias et al.	7,027,849	B2	4/2006	Al-Ali
6,515,273	B2	2/2003	Al-Ali	7,030,749	B2	4/2006	Al-Ali
6,517,497	B2	2/2003	Rymut et al.	7,035,684	B2	4/2006	Lee
6,519,487	B1	2/2003	Parker	7,039,449	B2	5/2006	Al-Ali
6,525,386	B1	2/2003	Mills et al.	7,041,060	B2	5/2006	Flaherty et al.
6,526,300	B1	2/2003	Kiani et al.	7,044,918	B2	5/2006	Diab
6,541,756	B2	4/2003	Schulz et al.	7,067,893	B2	6/2006	Mills et al.
6,542,764	B1	4/2003	Al-Ali et al.	7,096,052	B2	8/2006	Mason et al.
6,580,086	B1	6/2003	Schulz et al.	7,096,054	B2	8/2006	Abdul-Hafiz et al.
6,584,336	B1	6/2003	Ali et al.	7,096,060	B2	8/2006	Arand et al.
6,595,316	B2	7/2003	Cybulski et al.	7,110,804	B2	9/2006	Baumer et al.
6,597,932	B2	7/2003	Tian et al.	7,132,641	B2	11/2006	Schulz et al.
6,597,933	B2	7/2003	Kiani et al.	7,142,901	B2	11/2006	Kiani et al.
6,606,511	B1	8/2003	Ali et al.	7,149,561	B2	12/2006	Diab
6,632,181	B2	10/2003	Flaherty et al.	7,186,966	B2	3/2007	Al-Ali
6,639,668	B1	10/2003	Trepagnier	7,190,261	B2	3/2007	Al-Ali
6,640,116	B2	10/2003	Diab	7,215,984	B2	5/2007	Diab
6,643,530	B2	11/2003	Diab et al.	7,215,986	B2	5/2007	Diab
6,650,917	B2	11/2003	Diab et al.	7,221,971	B2	5/2007	Diab
6,654,624	B2	11/2003	Diab et al.	7,225,006	B2	5/2007	Al-Ali et al.
6,658,276	B2	12/2003	Kiani et al.	7,225,007	B2	5/2007	Al-Ali
6,661,161	B1	12/2003	Lanzo et al.	RE39,672	E	6/2007	Shehada et al.
6,671,531	B2	12/2003	Al-Ali et al.	7,239,905	B2	7/2007	Kiani-Azarbayjany et al.
6,678,543	B2	1/2004	Diab et al.	7,245,953	B1	7/2007	Parker
6,684,090	B2	1/2004	Ali et al.	7,246,069	B1	7/2007	O'Hanlon et al.
6,684,091	B2	1/2004	Parker	7,254,429	B2	8/2007	Schurman et al.
6,697,656	B1	2/2004	Al-Ali	7,254,431	B2	8/2007	Al-Ali
6,697,657	B1	2/2004	Shehada et al.	7,254,433	B2	8/2007	Diab et al.
6,697,658	B2	2/2004	Al-Ali	7,254,434	B2	8/2007	Schulz
RE38,476	E	3/2004	Diab et al.	7,270,126	B2	9/2007	Wallace et al.
6,699,194	B1	3/2004	Diab et al.	7,272,425	B2	9/2007	Al-Ali
6,702,755	B1	3/2004	Stasz et al.	7,274,955	B2	9/2007	Kiani et al.
6,714,804	B2	3/2004	Al-Ali et al.	D554,263	S	10/2007	Al-Ali
RE38,492	E	4/2004	Diab et al.	7,280,858	B2	10/2007	Al-Ali et al.
6,721,582	B2	4/2004	Trepagnier et al.	7,289,835	B2	10/2007	Mansfield et al.
6,721,585	B1	4/2004	Parker	7,292,883	B2	11/2007	De Felice et al.
6,725,075	B2	4/2004	Al-Ali	7,295,866	B2	11/2007	Al-Ali
6,728,560	B2	4/2004	Kollias et al.	7,328,053	B1	2/2008	Diab et al.
6,735,459	B2	5/2004	Parker	7,332,784	B2	2/2008	Mills et al.
6,745,060	B2	6/2004	Diab et al.	7,340,287	B2	3/2008	Mason et al.
6,760,607	B2	7/2004	Al-Ali	7,341,559	B2	3/2008	Schulz et al.
6,770,028	B1	8/2004	Ali et al.	7,343,186	B2	3/2008	Lamego et al.
6,771,994	B2	8/2004	Kiani et al.	D566,282	S	4/2008	Al-Ali et al.
6,792,300	B1	9/2004	Diab et al.	7,355,512	B1	4/2008	Al-Ali
6,813,511	B2	11/2004	Diab et al.	7,356,365	B2	4/2008	Schurman
6,816,741	B2	11/2004	Diab	7,361,148	B2	4/2008	Narimatsu
				7,368,855	B2	5/2008	Orten
				7,371,981	B2	5/2008	Abdul-Hafiz
				7,373,193	B2	5/2008	Al-Ali et al.
				7,373,194	B2	5/2008	Weber et al.

(56)

References Cited

U.S. PATENT DOCUMENTS

7,376,453	B1	5/2008	Diab et al.	7,957,780	B2	6/2011	Lamego et al.
7,377,794	B2	5/2008	Al-Ali et al.	7,962,188	B2	6/2011	Kiani et al.
7,377,899	B2	5/2008	Weber et al.	7,962,190	B1	6/2011	Diab et al.
7,383,070	B2	6/2008	Diab et al.	7,976,472	B2	7/2011	Kiani
7,415,297	B2	8/2008	Al-Ali et al.	7,976,480	B2	7/2011	Grajales et al.
7,428,432	B2	9/2008	Ali et al.	7,988,637	B2	8/2011	Diab
7,438,683	B2	10/2008	Al-Ali et al.	7,988,688	B2	8/2011	Webb et al.
7,440,787	B2	10/2008	Diab	7,990,382	B2	8/2011	Kiani
7,454,240	B2	11/2008	Diab et al.	7,991,446	B2	8/2011	Al-Ali et al.
7,467,002	B2	12/2008	Weber et al.	8,000,761	B2	8/2011	Al-Ali
7,469,157	B2	12/2008	Diab et al.	8,008,088	B2	8/2011	Bellott et al.
7,469,158	B2	12/2008	Cutler et al.	RE42,753	E	9/2011	Kiani-Azarbayjany et al.
7,471,969	B2	12/2008	Diab et al.	8,019,400	B2	9/2011	Diab et al.
7,471,971	B2	12/2008	Diab et al.	8,028,701	B2	10/2011	Al-Ali et al.
7,483,729	B2	1/2009	Al-Ali et al.	8,029,765	B2	10/2011	Bellott et al.
7,483,730	B2	1/2009	Diab et al.	8,036,727	B2	10/2011	Schurman et al.
7,489,958	B2	2/2009	Diab et al.	8,036,728	B2	10/2011	Diab et al.
7,496,391	B2	2/2009	Diab et al.	8,046,040	B2	10/2011	Ali et al.
7,496,393	B2	2/2009	Diab et al.	8,046,041	B2	10/2011	Diab et al.
D587,657	S	3/2009	Al-Ali et al.	8,046,042	B2	10/2011	Diab et al.
7,499,741	B2	3/2009	Diab et al.	8,048,040	B2	11/2011	Kiani
7,499,835	B2	3/2009	Weber et al.	8,050,728	B2	11/2011	Al-Ali et al.
7,500,950	B2	3/2009	Al-Ali et al.	8,092,396	B2	1/2012	Bagha et al.
7,509,154	B2	3/2009	Diab et al.	8,108,039	B2	1/2012	Saliga et al.
7,509,494	B2	3/2009	Al-Ali	RE43,169	E	2/2012	Parker
7,510,849	B2	3/2009	Schurman et al.	8,118,620	B2	2/2012	Al-Ali et al.
7,515,044	B2	4/2009	Welch et al.	8,121,673	B2	2/2012	Tran
7,526,328	B2	4/2009	Diab et al.	8,126,528	B2	2/2012	Diab et al.
7,530,942	B1	5/2009	Diab	8,128,572	B2	3/2012	Diab et al.
7,530,949	B2	5/2009	Al Ali et al.	8,130,105	B2	3/2012	Al-Ali et al.
7,530,955	B2	5/2009	Diab et al.	8,145,287	B2	3/2012	Diab et al.
7,563,110	B2	7/2009	Al-Ali et al.	8,150,487	B2	4/2012	Diab et al.
7,596,398	B2	9/2009	Al-Ali et al.	8,175,672	B2	5/2012	Parker
7,618,375	B2	11/2009	Flaherty	8,180,420	B2	5/2012	Diab et al.
D606,659	S	12/2009	Kiani et al.	8,182,443	B1	5/2012	Kiani
7,625,117	B2	12/2009	Haslett et al.	8,185,180	B2	5/2012	Diab et al.
7,647,083	B2	1/2010	Al-Ali et al.	8,190,223	B2	5/2012	Al-Ali et al.
D609,193	S	2/2010	Al-Ali et al.	8,190,227	B2	5/2012	Diab et al.
7,662,105	B2	2/2010	Hatlestad	8,203,438	B2	6/2012	Kiani et al.
D614,305	S	4/2010	Al-Ali et al.	8,203,704	B2	6/2012	Merritt et al.
RE41,317	E	5/2010	Parker	8,204,566	B2	6/2012	Schurman et al.
7,729,733	B2	6/2010	Al-Ali et al.	8,219,172	B2	7/2012	Schurman et al.
7,734,320	B2	6/2010	Al-Ali	8,224,411	B2	7/2012	Al-Ali et al.
7,761,127	B2	7/2010	Al-Ali et al.	8,228,181	B2	7/2012	Al-Ali et al.
7,761,128	B2	7/2010	Al-Ali et al.	8,229,533	B2	7/2012	Diab et al.
7,764,982	B2	7/2010	Dalke et al.	8,233,955	B2	7/2012	Al-Ali et al.
D621,516	S	8/2010	Kiani et al.	8,241,223	B2	8/2012	Gavriely et al.
7,783,056	B2	8/2010	Wilmlink	8,244,325	B2	8/2012	Al-Ali et al.
7,791,155	B2	9/2010	Diab	8,255,026	B1	8/2012	Al-Ali
7,801,581	B2	9/2010	Diab	8,255,027	B2	8/2012	Al-Ali et al.
7,806,226	B2	10/2010	Drummong et al.	8,255,028	B2	8/2012	Al-Ali et al.
7,822,452	B2	10/2010	Schurman et al.	8,260,577	B2	9/2012	Weber et al.
RE41,912	E	11/2010	Parker	8,265,291	B2	9/2012	Bridger et al.
7,844,313	B2	11/2010	Kiani et al.	8,265,723	B1	9/2012	McHale et al.
7,844,314	B2	11/2010	Al-Ali	8,274,360	B2	9/2012	Sampath et al.
7,844,315	B2	11/2010	Al-Ali	8,275,140	B2	9/2012	Smith
7,860,553	B2	12/2010	Goveri et al.	8,301,217	B2	10/2012	Al-Ali et al.
7,865,222	B2	1/2011	Weber et al.	8,306,596	B2	11/2012	Schurman et al.
7,873,497	B2	1/2011	Weber et al.	8,310,336	B2	11/2012	Muhsin et al.
7,880,606	B2	2/2011	Al-Ali	8,315,683	B2	11/2012	Al-Ali et al.
7,880,626	B2	2/2011	Al-Ali et al.	8,320,576	B1	11/2012	Abbruscato
7,891,355	B2	2/2011	Al-Ali et al.	RE43,860	E	12/2012	Parker
7,894,868	B2	2/2011	Al-Ali et al.	8,337,403	B2	12/2012	Al-Ali et al.
7,899,507	B2	3/2011	Al-Ali et al.	8,346,330	B2	1/2013	Lamego
7,899,518	B2	3/2011	Trepagnier et al.	8,353,842	B2	1/2013	Al-Ali et al.
7,904,132	B2	3/2011	Weber et al.	8,355,766	B2	1/2013	MacNeish, III et al.
7,909,772	B2	3/2011	Popov et al.	8,359,080	B2	1/2013	Diab et al.
7,910,875	B2	3/2011	Al-Ali	8,364,223	B2	1/2013	Al-Ali et al.
7,919,713	B2	4/2011	Al-Ali et al.	8,364,226	B2	1/2013	Diab et al.
7,937,128	B2	5/2011	Al-Ali	8,374,665	B2	2/2013	Lamego
7,937,129	B2	5/2011	Mason et al.	8,385,995	B2	2/2013	Al-ali et al.
7,937,130	B2	5/2011	Diab et al.	8,385,996	B2	2/2013	Smith et al.
7,940,937	B2	5/2011	Smith	8,388,353	B2	3/2013	Kiani et al.
7,941,199	B2	5/2011	Kiani	8,396,228	B2	3/2013	Bilan
7,951,086	B2	5/2011	Flaherty et al.	8,399,822	B2	3/2013	Al-Ali
				8,401,602	B2	3/2013	Kiani
				8,403,865	B2	3/2013	Halperin et al.
				8,405,608	B2	3/2013	Al-Ali et al.
				8,414,499	B2	4/2013	Al-Ali et al.

(56)

References Cited

U.S. PATENT DOCUMENTS

8,418,524 B2	4/2013	Al-Ali	8,755,856 B2	6/2014	Diab et al.
8,423,106 B2	4/2013	Lamego et al.	8,755,872 B1	6/2014	Marinow
8,428,967 B2	4/2013	Olsen et al.	8,761,850 B2	6/2014	Lamego
8,430,817 B1	4/2013	Al-Ali et al.	8,764,671 B2	7/2014	Kiani
8,437,825 B2	5/2013	Dalvi et al.	8,768,423 B2	7/2014	Shakespeare et al.
8,449,469 B2	5/2013	Banet et al.	8,771,204 B2	7/2014	Telfort et al.
8,455,290 B2	6/2013	Siskavich	8,777,634 B2	7/2014	Kiani et al.
8,457,703 B2	6/2013	Al-Ali	8,781,543 B2	7/2014	Diab et al.
8,457,707 B2	6/2013	Kiani	8,781,544 B2	7/2014	Al-Ali et al.
8,463,349 B2	6/2013	Diab et al.	8,781,549 B2	7/2014	Al-Ali et al.
8,466,286 B2	6/2013	Bellot et al.	8,788,003 B2	7/2014	Schurman et al.
8,471,713 B2	6/2013	Poeze et al.	8,790,268 B2	7/2014	Al-Ali et al.
8,473,020 B2	6/2013	Kiani et al.	8,801,613 B2	8/2014	Al-Ali et al.
8,483,787 B2	7/2013	Al-Ali et al.	8,821,397 B2	9/2014	Al-Ali et al.
8,489,364 B2	7/2013	Weber et al.	8,821,415 B2	9/2014	Al-Ali et al.
8,491,489 B2	7/2013	Shin et al.	8,830,449 B1	9/2014	Lamego et al.
8,498,684 B2	7/2013	Weber et al.	8,831,700 B2	9/2014	Schurman et al.
8,504,128 B2	8/2013	Blank et al.	8,852,994 B2	10/2014	Wojtczuk et al.
8,509,867 B2	8/2013	Workman et al.	8,868,147 B2	10/2014	Stippick et al.
8,515,509 B2	8/2013	Bruinsma et al.	8,868,150 B2	10/2014	Al-Ali et al.
8,517,981 B2	8/2013	Zornow	8,870,792 B2	10/2014	Al-Ali et al.
8,523,781 B2	9/2013	Al-Ali	8,886,271 B2	11/2014	Kiani et al.
8,526,665 B2	9/2013	Lutz et al.	8,888,539 B2	11/2014	Al-Ali et al.
8,529,301 B2	9/2013	Al-Ali et al.	8,888,708 B2	11/2014	Diab et al.
8,532,727 B2	9/2013	Ali et al.	8,892,180 B2	11/2014	Weber et al.
8,532,728 B2	9/2013	Diab et al.	8,897,847 B2	11/2014	Al-Ali
D692,145 S	10/2013	Al-Ali et al.	8,909,310 B2	12/2014	Lamego et al.
8,547,209 B2	10/2013	Kiani et al.	8,961,413 B2	2/2015	Teller et al.
8,548,548 B2	10/2013	Al-Ali	9,028,429 B2	5/2015	Telfort et al.
8,548,549 B2	10/2013	Schurman et al.	9,037,207 B2	5/2015	Al-Ali et al.
8,548,550 B2	10/2013	Al-Ali et al.	9,060,721 B2	6/2015	Reichgott et al.
8,560,032 B2	10/2013	Al-Ali et al.	9,066,666 B2	6/2015	Kiani
8,560,034 B1	10/2013	Diab et al.	9,066,680 B1	6/2015	Al-Ali et al.
8,570,167 B2	10/2013	Al-Ali	9,072,474 B2	7/2015	Al-Ali et al.
8,570,503 B2	10/2013	Vo et al.	9,078,560 B2	7/2015	Schurman et al.
8,571,618 B1	10/2013	Lamego et al.	9,084,569 B2	7/2015	Weber et al.
8,571,619 B2	10/2013	Al-Ali et al.	9,095,316 B2	8/2015	Welch et al.
8,577,431 B2	11/2013	Lamego et al.	9,106,038 B2	8/2015	Telfort et al.
8,581,732 B2	11/2013	Al-Ali et al.	9,107,625 B2	8/2015	Telfort et al.
8,584,345 B2	11/2013	Al-Ali et al.	9,107,626 B2	8/2015	Al-Ali et al.
8,588,880 B2	11/2013	Abdul-Hafiz et al.	9,113,831 B2	8/2015	Al-Ali
8,600,467 B2	12/2013	Al-Ali et al.	9,113,832 B2	8/2015	Al-Ali
8,606,342 B2	12/2013	Diab	9,119,595 B2	9/2015	Lamego
8,626,255 B2	1/2014	Al-Ali et al.	9,131,881 B2	9/2015	Diab et al.
8,630,691 B2	1/2014	Lamego et al.	9,131,882 B2	9/2015	Al-Ali et al.
8,634,889 B2	1/2014	Al-Ali et al.	9,131,883 B2	9/2015	Al-Ali
8,641,595 B2	2/2014	Basinger	9,131,917 B2	9/2015	Telfort et al.
8,641,631 B2	2/2014	Sierra et al.	9,138,180 B1	9/2015	Coverston et al.
8,652,060 B2	2/2014	Al-Ali et al.	9,138,182 B2	9/2015	Al-Ali et al.
8,663,107 B2	3/2014	Kiani	9,138,192 B2	9/2015	Weber et al.
8,666,468 B1	3/2014	Al-Ali	9,142,117 B2	9/2015	Muhsin et al.
8,667,967 B2	3/2014	Al-Ali et al.	9,153,112 B1	10/2015	Kiani et al.
8,670,811 B2	3/2014	O'Reilly	9,153,121 B2	10/2015	Kiani et al.
8,670,814 B2	3/2014	Diab et al.	9,161,696 B2	10/2015	Al-Ali et al.
8,676,286 B2	3/2014	Weber et al.	9,161,713 B2	10/2015	Al-Ali et al.
8,682,407 B2	3/2014	Al-Ali	9,167,995 B2	10/2015	Lamego et al.
RE44,823 E	4/2014	Parker	9,176,141 B2	11/2015	Al-Ali et al.
RE44,875 E	4/2014	Kiani et al.	9,186,102 B2	11/2015	Bruinsma et al.
8,688,189 B2	4/2014	Shennib	9,192,351 B1	11/2015	Telfort et al.
8,690,799 B2	4/2014	Telfort et al.	9,326,712 B1	5/2016	Kiani
8,700,112 B2	4/2014	Kiani	9,370,335 B2	6/2016	Al-Ali et al.
8,702,627 B2	4/2014	Telfort et al.	9,386,961 B2	7/2016	Al-Ali et al.
8,706,179 B2	4/2014	Parker	9,538,980 B2	1/2017	Telfort et al.
8,712,494 B1	4/2014	MacNeish, III et al.	2003/0149349 A1	8/2003	Jensen
8,715,206 B2	5/2014	Telfort et al.	2003/0196660 A1	10/2003	Haveri
8,718,735 B2	5/2014	Lamego et al.	2004/0215094 A1	10/2004	Baumer et al.
8,718,737 B2	5/2014	Diab et al.	2005/0033128 A1	2/2005	Ali
8,718,738 B2	5/2014	Blank et al.	2005/0065417 A1	3/2005	Ali
8,720,249 B2	5/2014	Al-Ali	2006/0047215 A1	3/2006	Newman et al.
8,721,541 B2	5/2014	Al-Ali et al.	2006/0094943 A1	5/2006	Van Slyke
8,721,542 B2	5/2014	Al-Ali et al.	2006/0184052 A1	8/2006	Iwasawa
8,723,677 B1	5/2014	Kiani	2006/0190051 A1	8/2006	Gerber et al.
8,740,792 B1	6/2014	Kiani et al.	2006/0198533 A1	9/2006	Wang
8,754,776 B2	6/2014	Poeze et al.	2006/0264767 A1	11/2006	Shennib
8,755,535 B2	6/2014	Telfort et al.	2007/0016030 A1	1/2007	Stringer
			2007/0049837 A1	3/2007	Shertukde et al.
			2007/0058818 A1	3/2007	Yoshimine
			2007/0106179 A1	5/2007	Bagha et al.
			2007/0147639 A1	6/2007	Richardson et al.

(56)

References Cited

U.S. PATENT DOCUMENTS

2007/0165872	A1	7/2007	Bridger et al.	2013/0178749	A1	7/2013	Lamego
2007/0167855	A1	7/2007	Shin et al.	2013/0190581	A1	7/2013	Al-Ali et al.
2007/0173730	A1	7/2007	Bikko	2013/0197328	A1	8/2013	Diab et al.
2007/0208262	A1	9/2007	Kovacs	2013/0211214	A1	8/2013	Olsen
2007/0255153	A1	11/2007	Kumar et al.	2013/0243021	A1	9/2013	Siskavich
2007/0282174	A1	12/2007	Sabatino	2013/0253334	A1	9/2013	Al-Ali et al.
2008/0039735	A1	2/2008	Hickerson	2013/0274571	A1	10/2013	Diab et al.
2008/0076972	A1	3/2008	Dorogusker et al.	2013/0296672	A1	11/2013	O'Neil et al.
2008/0077026	A1	3/2008	Banet et al.	2013/0317327	A1	11/2013	Al-Ali et al.
2008/0077435	A1	3/2008	Muradia	2013/0317370	A1	11/2013	Dalvi et al.
2008/0093157	A1	4/2008	Drummond et al.	2013/0324808	A1	12/2013	Al-Ali et al.
2008/0097249	A1	4/2008	Pool et al.	2013/0324817	A1	12/2013	Diab
2008/0139953	A1	6/2008	Baker et al.	2013/0331670	A1	12/2013	Kiani
2008/0188733	A1	8/2008	Al-Ali et al.	2013/0338461	A1	12/2013	Lamego et al.
2008/0188760	A1	8/2008	Al-Ali	2014/0012100	A1	1/2014	Al-Ali et al.
2008/0219464	A1	9/2008	Smith	2014/0025306	A1	1/2014	Weber et al.
2008/0251313	A1	10/2008	Knight et al.	2014/0034353	A1	2/2014	Al-Ali et al.
2009/0076363	A1	3/2009	Bly et al.	2014/0051952	A1	2/2014	Reichgott et al.
2009/0093687	A1	4/2009	Telfort et al.	2014/0051953	A1	2/2014	Lamego et al.
2009/0170664	A1	7/2009	Shirasaki	2014/0051954	A1	2/2014	Al-Ali et al.
2009/0247924	A1	10/2009	Lamego et al.	2014/0058230	A1	2/2014	Abdul-Hafiz et al.
2009/0275844	A1	11/2009	Al-Ali	2014/0066783	A1	3/2014	Kiani et al.
2009/0299157	A1	12/2009	Telfort et al.	2014/0077956	A1	3/2014	Sampath et al.
2009/0316925	A1	12/2009	Eisenfeld et al.	2014/0081097	A1	3/2014	Al-Ali et al.
2010/0004518	A1	1/2010	Vo et al.	2014/0081100	A1	3/2014	Muhsin et al.
2010/0030040	A1	2/2010	Poeze et al.	2014/0081175	A1	3/2014	Telfort
2010/0069725	A1	3/2010	Al-Ali	2014/0094667	A1	4/2014	Schurman et al.
2010/0090901	A1	4/2010	Smith et al.	2014/0100434	A1	4/2014	Diab et al.
2010/0094096	A1	4/2010	Petruzzelli et al.	2014/0114199	A1	4/2014	Lamego et al.
2010/0204996	A1	8/2010	Zeng et al.	2014/0120564	A1	5/2014	Workman et al.
2010/0261979	A1	10/2010	Kiani	2014/0121482	A1	5/2014	Merritt et al.
2010/0305416	A1	12/2010	Bédard et al.	2014/0121483	A1	5/2014	Kiani
2010/0317936	A1	12/2010	Al-Ali et al.	2014/0125495	A1	5/2014	Al-Ali
2011/0001605	A1	1/2011	Kiani et al.	2014/0127137	A1	5/2014	Bellott et al.
2011/0028802	A1	2/2011	Addison	2014/0128696	A1	5/2014	Al-Ali
2011/0034831	A1	2/2011	Christensen et al.	2014/0128699	A1	5/2014	Al-Ali et al.
2011/0082711	A1	4/2011	Poeze et al.	2014/0129702	A1	5/2014	Lamego et al.
2011/0105854	A1	5/2011	Kiani et al.	2014/0135588	A1	5/2014	Al-Ali et al.
2011/0125060	A1	5/2011	Telfort et al.	2014/0142399	A1	5/2014	Al-Ali et al.
2011/0172561	A1	7/2011	Kiani et al.	2014/0142401	A1	5/2014	Al-Ali et al.
2011/0172967	A1	7/2011	Al-Ali et al.	2014/0142402	A1	5/2014	Al-Ali et al.
2011/0196211	A1	8/2011	Al-Ali	2014/0163344	A1	6/2014	Al-Ali
2011/0208015	A1	8/2011	Welch et al.	2014/0163402	A1	6/2014	Lamego et al.
2011/0209915	A1	9/2011	Fechter et al.	2014/0166076	A1	6/2014	Kiani et al.
2011/0213212	A1	9/2011	Al-Ali	2014/0171763	A1	6/2014	Diab
2011/0213273	A1	9/2011	Telfort et al.	2014/0180038	A1	6/2014	Kiani
2011/0230733	A1	9/2011	Al-Ali	2014/0180154	A1	6/2014	Sierra et al.
2011/0237911	A1	9/2011	Lamego et al.	2014/0194709	A1	7/2014	Al-Ali et al.
2011/0288431	A1	11/2011	Alshaer et al.	2014/0194711	A1	7/2014	Al-Ali
2012/0059267	A1	3/2012	Lamego et al.	2014/0194766	A1	7/2014	Al-Ali et al.
2012/0116175	A1	5/2012	Al-Ali et al.	2014/0200420	A1	7/2014	Al-Ali
2012/0179006	A1	7/2012	Jansen et al.	2014/0200422	A1	7/2014	Weber et al.
2012/0209082	A1	8/2012	Al-Ali	2014/0206963	A1	7/2014	Al-Ali
2012/0209084	A1	8/2012	Olsen et al.	2014/0213864	A1	7/2014	Abdul-Hafiz et al.
2012/0227739	A1	9/2012	Kiani	2014/0243627	A1	8/2014	Diab et al.
2012/0230523	A1	9/2012	Ehrlund	2014/0266790	A1	9/2014	Al-Ali et al.
2012/0232427	A1	9/2012	Bakema et al.	2014/0275808	A1	9/2014	Poeze et al.
2012/0265039	A1	10/2012	Kiani	2014/0275835	A1	9/2014	Lamego et al.
2012/0283524	A1	11/2012	Kiani et al.	2014/0275871	A1	9/2014	Lamego et al.
2012/0286955	A1	11/2012	Welch et al.	2014/0275872	A1	9/2014	Merritt et al.
2012/0296178	A1	11/2012	Lamego et al.	2014/0275881	A1	9/2014	Lamego et al.
2012/0302920	A1	11/2012	Bridger et al.	2014/0276115	A1	9/2014	Dalvi et al.
2012/0319816	A1	12/2012	Al-Ali	2014/0288400	A1	9/2014	Diab et al.
2012/0330112	A1	12/2012	Lamego et al.	2014/0309506	A1	10/2014	Lamego et al.
2013/0023775	A1	1/2013	Lamego et al.	2014/0316228	A1	10/2014	Blank et al.
2013/0041591	A1	2/2013	Lamego	2014/0323825	A1	10/2014	Al-Ali et al.
2013/0045685	A1	2/2013	Kiani	2014/0330092	A1	11/2014	Al-Ali et al.
2013/0046204	A1	2/2013	Lamego et al.	2014/0330098	A1	11/2014	Merritt et al.
2013/0060108	A1	3/2013	Schurman et al.	2014/0330099	A1	11/2014	Al-Ali et al.
2013/0060147	A1	3/2013	Welch et al.	2014/0333440	A1	11/2014	Kiani
2013/0079610	A1	3/2013	Al-Ali	2014/0336481	A1	11/2014	Shakespeare et al.
2013/0096405	A1	4/2013	Garfio	2014/0343436	A1	11/2014	Kiani
2013/0096936	A1	4/2013	Sampath et al.	2015/0025406	A1	1/2015	Al-Ali
2013/0109935	A1	5/2013	Al-Ali et al.	2015/0099998	A1	4/2015	Christensen et al.
2013/0162433	A1	6/2013	Muhsin et al.	2016/0045118	A1	2/2016	Kiani
				2016/0066879	A1	3/2016	Telfort et al.
				2017/0007190	A1	1/2017	Al-Ali et al.

(56) **References Cited**

U.S. PATENT DOCUMENTS

2017/0007198 A1 1/2017 Al-Ali et al.
2017/0079594 A1 3/2017 Telfort et al.

FOREIGN PATENT DOCUMENTS

CN 201497610 6/2010
CN 202005761 10/2011
EP 0716628 B1 12/1998
EP 0659058 B1 1/1999
EP 0956820 A1 11/1999
EP 1518442 A1 3/2005
EP 2014234 A1 1/2009
EP 1207536 A2 2/2010
EP 2391273 A2 12/2011
EP 2488106 8/2012
EP 2488978 8/2012
EP 2710959 3/2014
FR 2 847 796 6/2004
GB 2358546 7/2001
JP S56-031742 A 3/1961
JP S53-094482 A 8/1978
JP 60059900 4/1985
JP 6214898 1/1987
JP 01-309872 12/1989
JP H04-317637 A 11/1992
JP H07-152553 A 6/1995
JP 10-155755 6/1998
JP 2001-50713 2/2001
JP 2003-329719 11/2003
JP 2005-522292 A 7/2005
JP 2005-531230 A 10/2005
JP 2012-513872 6/2012
JP 2013-508029 3/2013
JP 2013-508030 3/2013
NO 20040819 2/2004
WO WO 94/05207 3/1994
WO WO 94/13207 6/1994
WO WO 95/29632 11/1995
WO WO 99/53277 10/1999
WO WO 00/10462 3/2000
WO WO 01/34033 5/2001
WO WO 01/87005 11/2001
WO WO 01/97691 12/2001
WO WO 01/78059 3/2002
WO WO 02/024067 7/2002
WO WO 02/003042 12/2002
WO WO 03/058646 7/2003
WO WO 03/087737 10/2003
WO WO 2004/000111 12/2003
WO WO 2004/004411 1/2004
WO WO 2004/078038 9/2004
WO WO 2005/096931 10/2005
WO WO 2005/099562 10/2005
WO WO 2008/017246 2/2008
WO WO 2008/148172 12/2008
WO WO 2009/137524 11/2009
WO WO 2009/155593 12/2009
WO WO 2010/078168 7/2010
WO WO 2011/047211 4/2011
WO WO 2011/047213 4/2011
WO WO 2011/047216 8/2011
WO WO 2011/047207 9/2011
WO WO 2011/047209 3/2012
WO WO 2013/056141 4/2013

OTHER PUBLICATIONS

US 8,845,543, 09/2014, Diab et al. (withdrawn)
Eldor et al., "A device for monitoring ventilation during anaesthesia; the paratracheal audible respiratory monitor", Canadian Journal of Anaesthesia, 1990, vol. 9, No. 1. Peg. 95-98.
Analog Devices, 12-Bit Serial Input Multiplying D/A Converter, Product Data Sheet, 2000.

Avago Technologies, "HCNR200 and HCNR201, High-Linearity Analog Optocouplers," Data Sheet, Avago Technologies, Nov. 18, 2008.

Eldor et al., "A device for monitoring ventilation during anesthesia; the paratracheal audible respiratory monitor", Canadian Journal of Anesthesia, 1990, vol. 9, No. 1, p. 95-98.

Images showing tear down of a Measurement Specialties' stethoscope, Images taken on Sep. 7, 2007, in 38 pages.

Sierra et al., Monitoring Respiratory Rate Based on Tracheal Sounds. First Experiences, Proceedings of the 26th Annual Int'l Conf. of the IEEE EMBS (Sep. 2004), 317-320.

WelchAllyn OEM Technologies, ECG Asic, ECG 3-lead, 5-lead, 12-lead and RESP Signal Processing, ECG Asic Part No. 000.91163 (2001).

White, "Advanced Compression Techniques, Tips & Tricks", Part 1 and Part 2, Dec. 2000 and Jan. 2001 in 11 pages.

Oversampling by Wikipedia, the free encyclopedia, pub. Online Oct. 7, 2012 at "https://wikipedia.org/w/index.php?title=Oversampling&oldid=516454012", accessed Sep. 3, 2015.

Pseudorandom noise by Wikipedia, the free encyclopedia, pub. Online Jul. 25, 2012 at "https://wikipedia.org/w/index.php?title=Pseudorandom_noise&oldid=504121479", accessed Sep. 3, 2015.

Noise generator by Wikipedia, the free encyclopedia, pub. Online May 6, 2012 at "https://wikipedia.org/w/index.php?title=Noise_generator&oldid=490897729", accessed Sep. 3, 2015.

International Search Report & Written Opinion, PCT Application PCT/US2010/052758, dated Feb. 10, 2011; 12 pages.

International Search Report & Written Opinion, PCT Application PCT/US2010/058981, dated Feb. 17, 2011; 11 pages.

International Search Report and Written Opinion for PCT/US2009/042902, dated Dec. 8, 2009.

International Search Report and Written Opinion in PCT/US2009/042902 dated Aug. 12, 2009 in 16 pages.

International Search Report, PCT Application PCT/CA2003/000536, dated Dec. 11, 2003; 2 pages.

EP Office Action dated May 18, 2011 in application No. 03711767.8.

Japanese Office Action re Application No. 2007-506626, dated Mar. 1, 2011.

PCT Invitation to Pay Fees and Initial Search Report in PCT/US2010/052756, dated Oct. 5, 2011.

International Search Report and Written Opinion in PCT/US2010/052756 dated Feb. 6, 2012 in 15 pages.

PCT Invitation to Pay Fees and Initial Search Report in PCT/US2009/069287, dated Apr. 21, 2010.

International Search Report and Written Opinion issued in PCT Application No. PCT/US2009/069287, dated Jun. 30, 2010.

Office Action in Japanese Application No. 2011-544508 dated Apr. 30, 2014.

EP Office Action dated Mar. 5, 2013 in application No. 10779086.7.

EP Office Action dated Jul. 11, 2016 in application No. 10779086.7.

PCT Invitation to Pay Fees and Initial Search Report in PCT/US2010/052754, dated Mar. 15, 2011.

International Search Report and Written Opinion in PCT/US2010/052754 dated Jul. 27, 2011.

International Preliminary Report on Patentability (IPRP) in PCT/US2010/052754 dated Apr. 26, 2012 in 11 pages.

International Search Report and Written Opinion in PCT/US2010/052760 dated Mar. 8, 2011 in 11 pages.

International Search Report and Written Opinion in PCT/US2010/052763, dated May 13, 2011.

International Preliminary Report on Patentability in PCT/US2010/052763 dated Apr. 17, 2012 in 9 pages.

International Search Report and Written Opinion in PCT Application No. PCT/US2012/060084 dated Dec. 21, 2012 in 11 pages.

International Preliminary Report on Patentability dated Apr. 15, 2014 for PCT Application No. PCT/US2012/060084.

European Search Report for Application No. 13185148.7 dated Dec. 6, 2013.

Office Action for Application No. 13185148.7 dated Apr. 4, 2017.

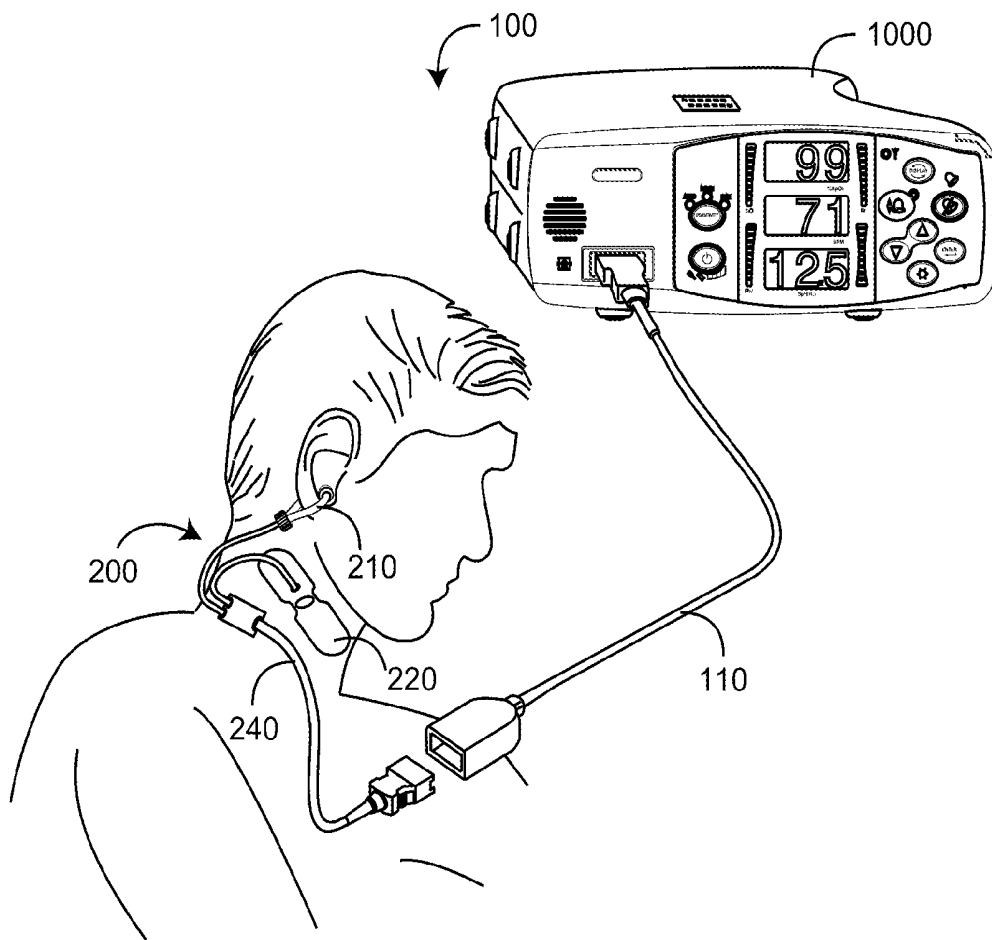

FIG. 1A

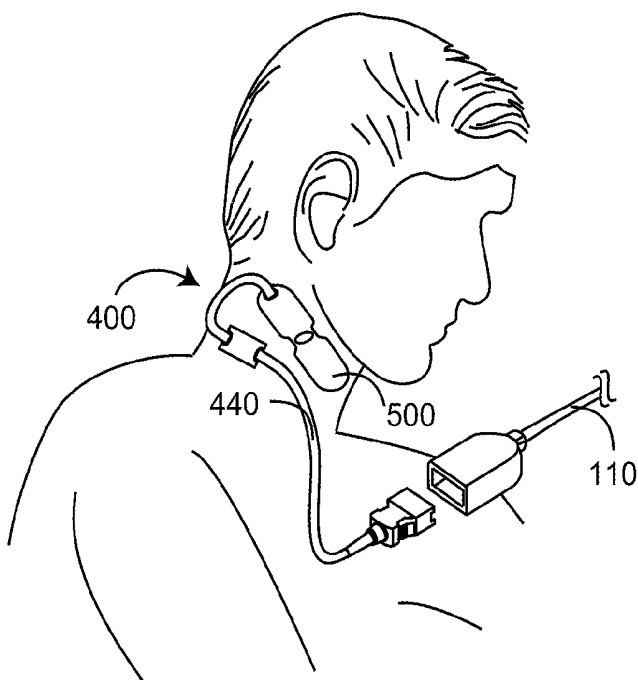

FIG. 1B

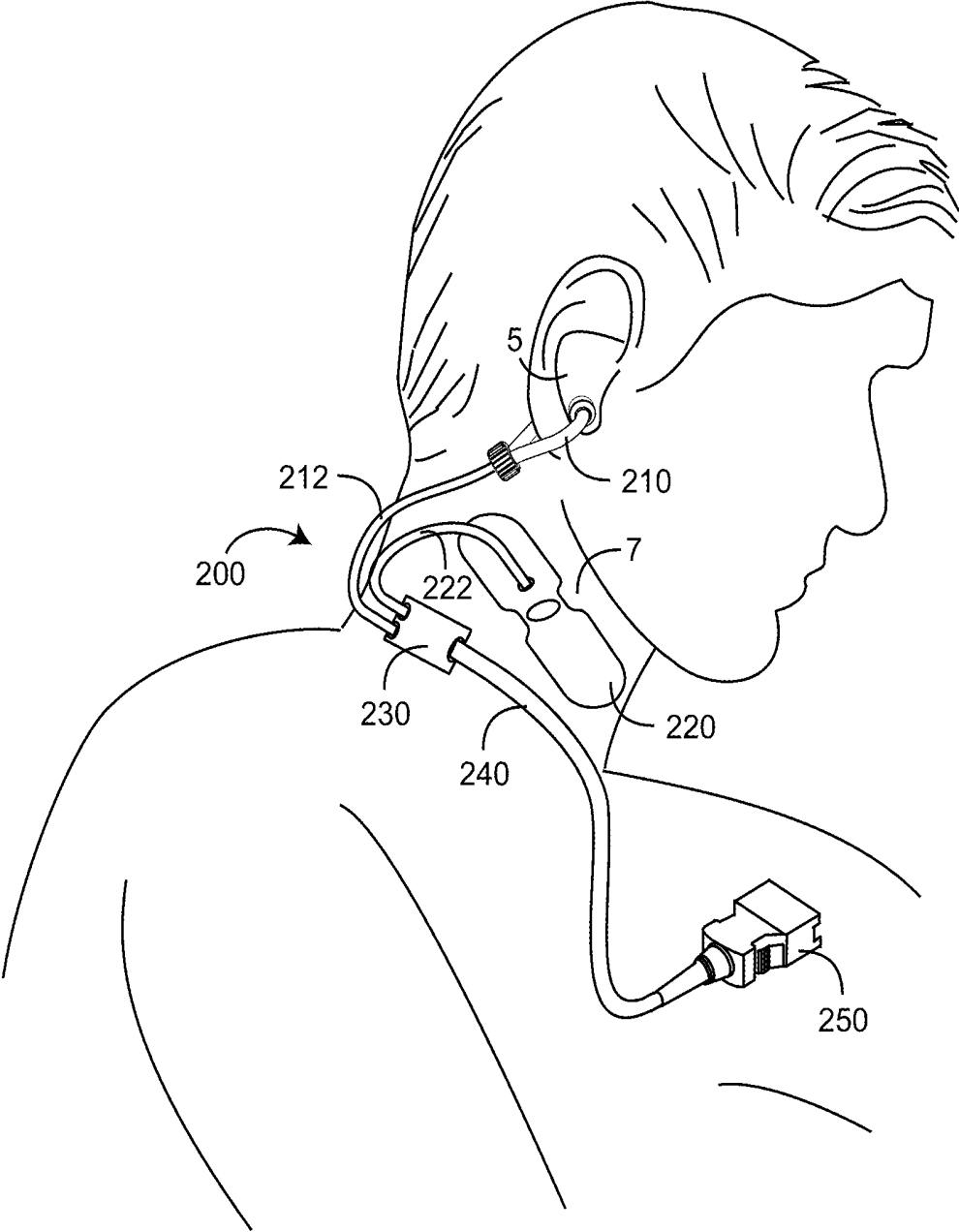

FIG. 2

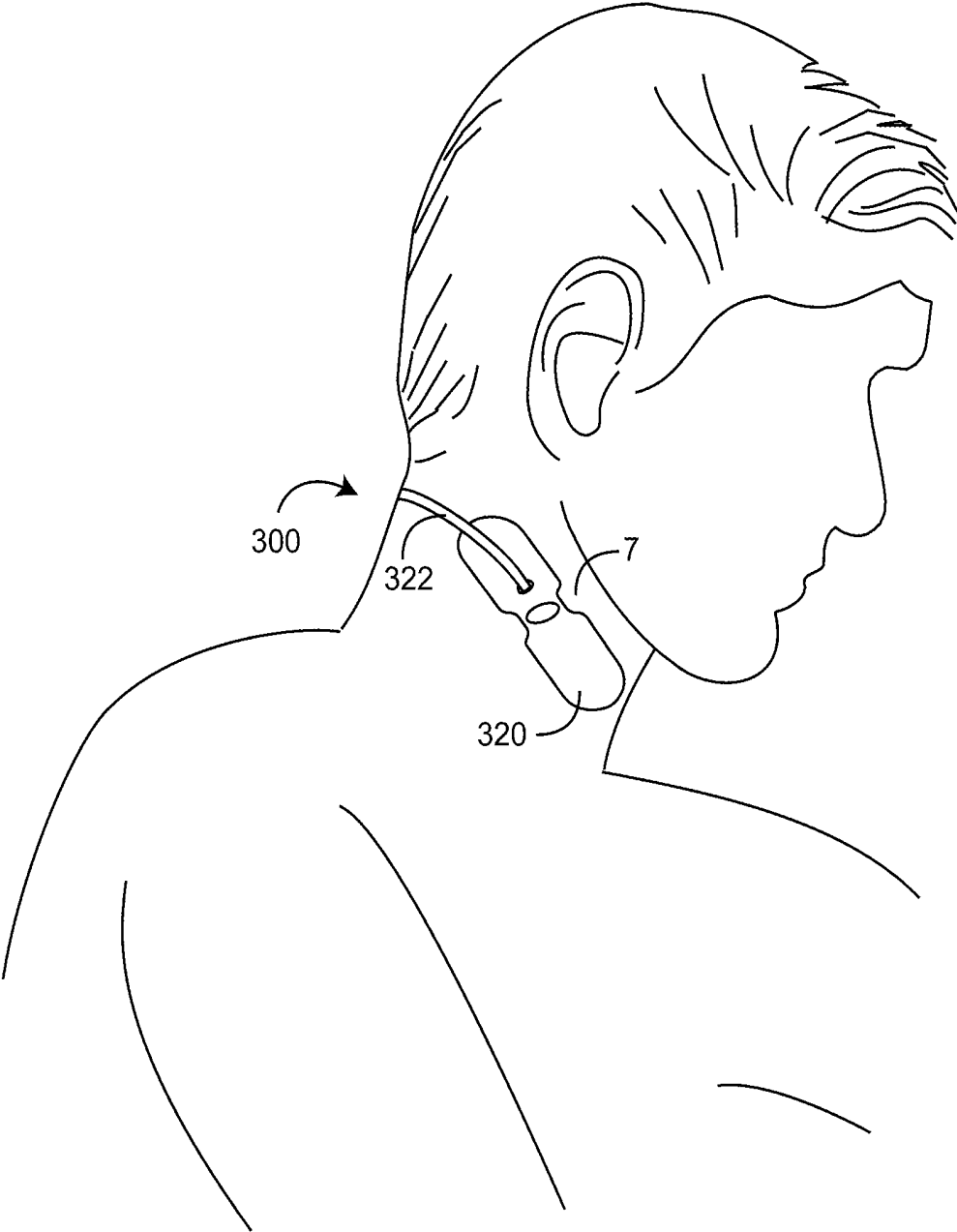

FIG. 3A

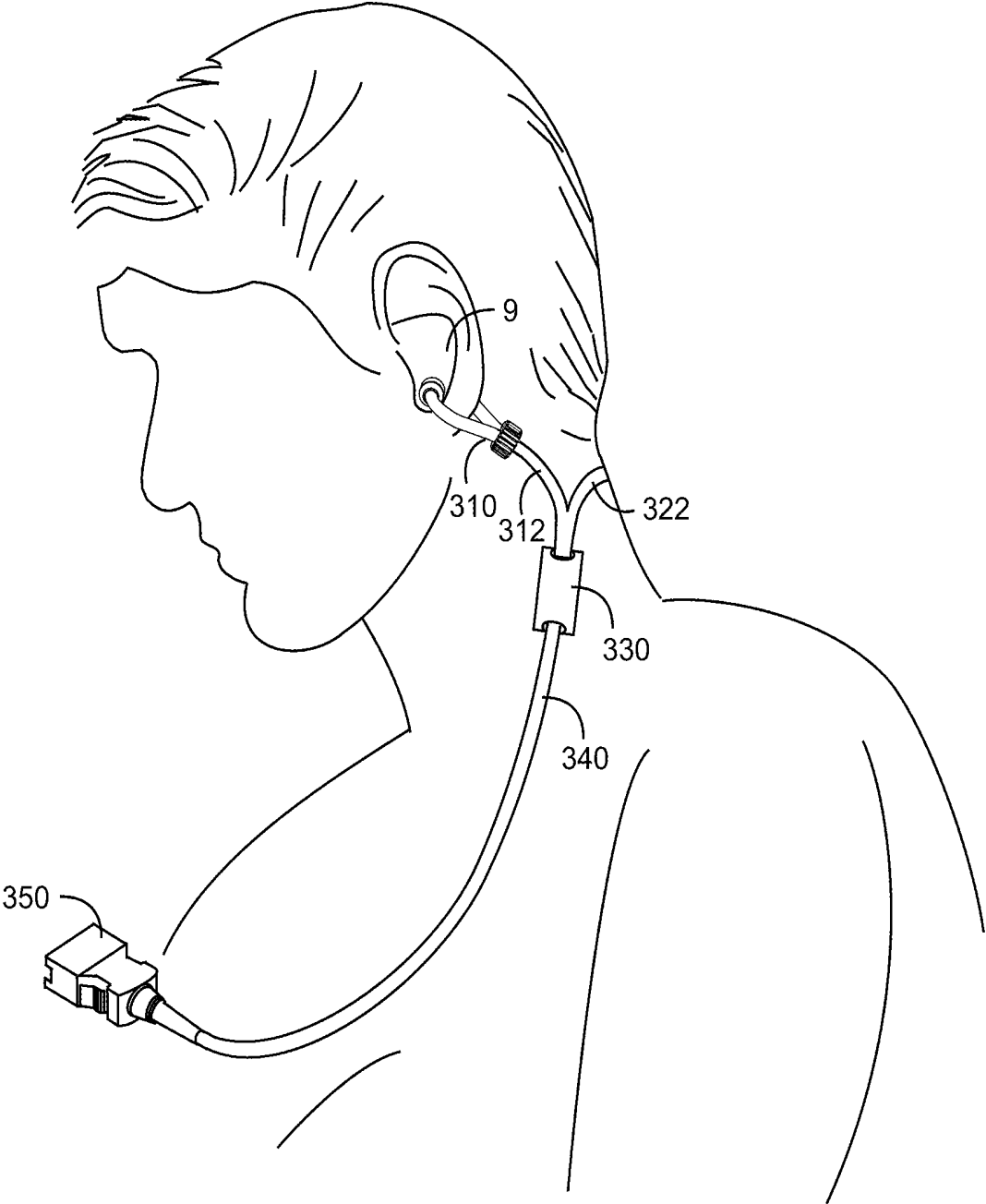

FIG. 3B

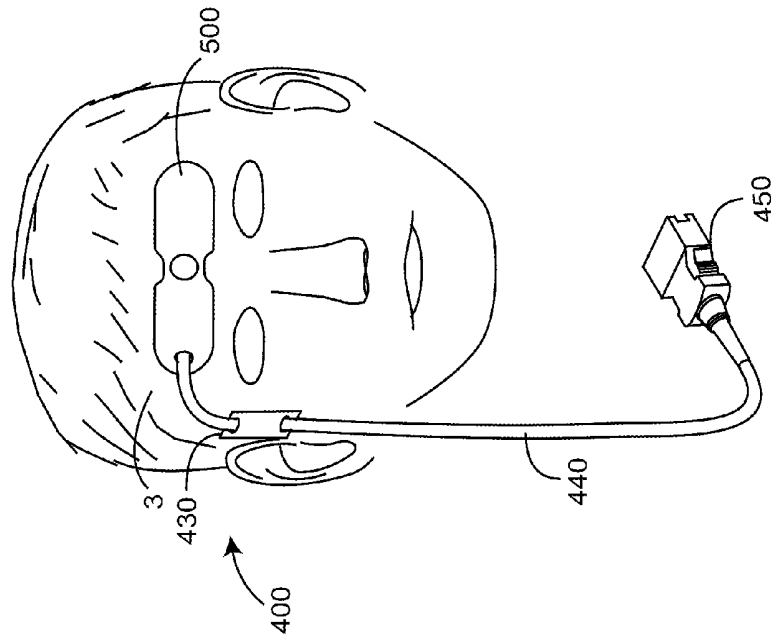

FIG. 4B

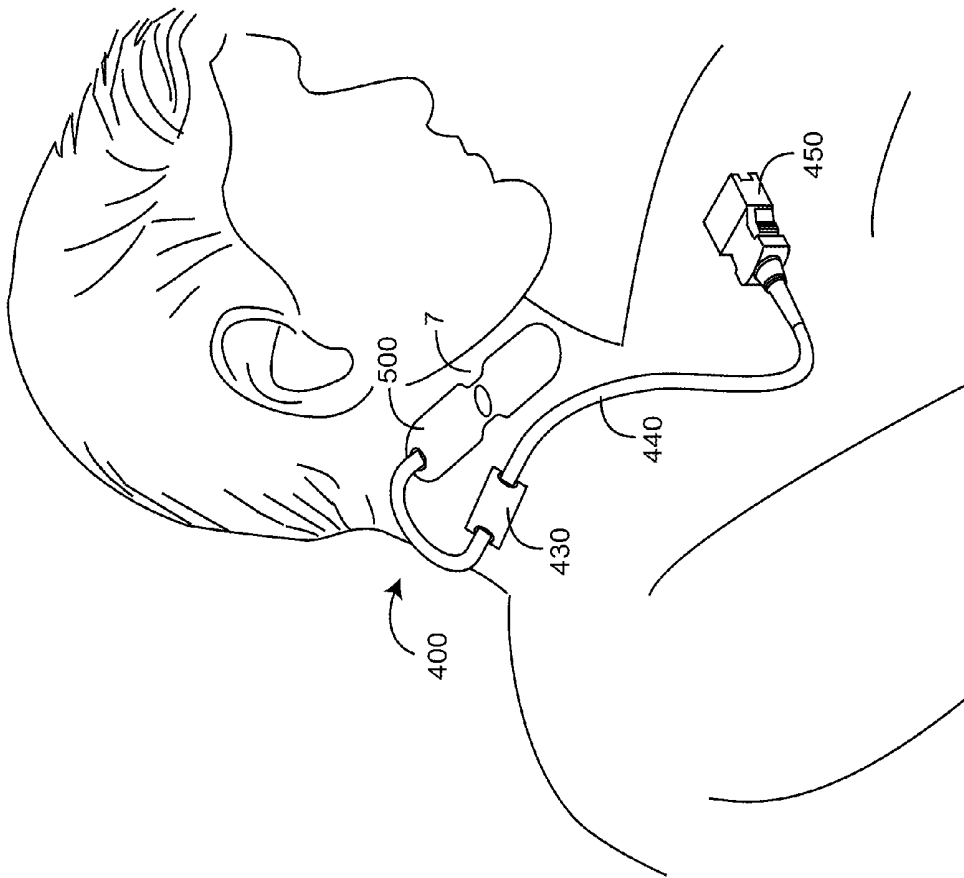

FIG. 4A

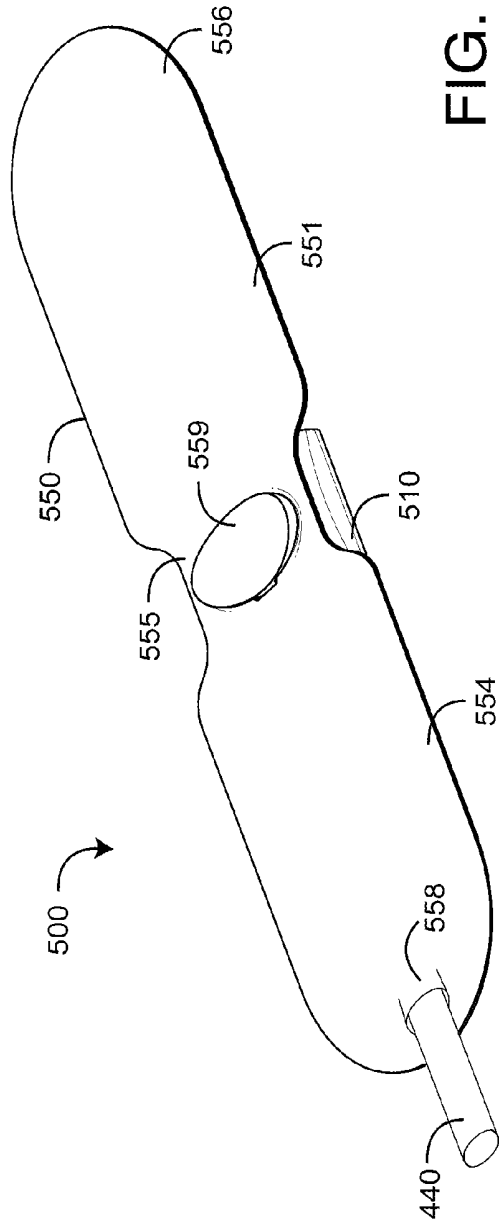

FIG. 5A

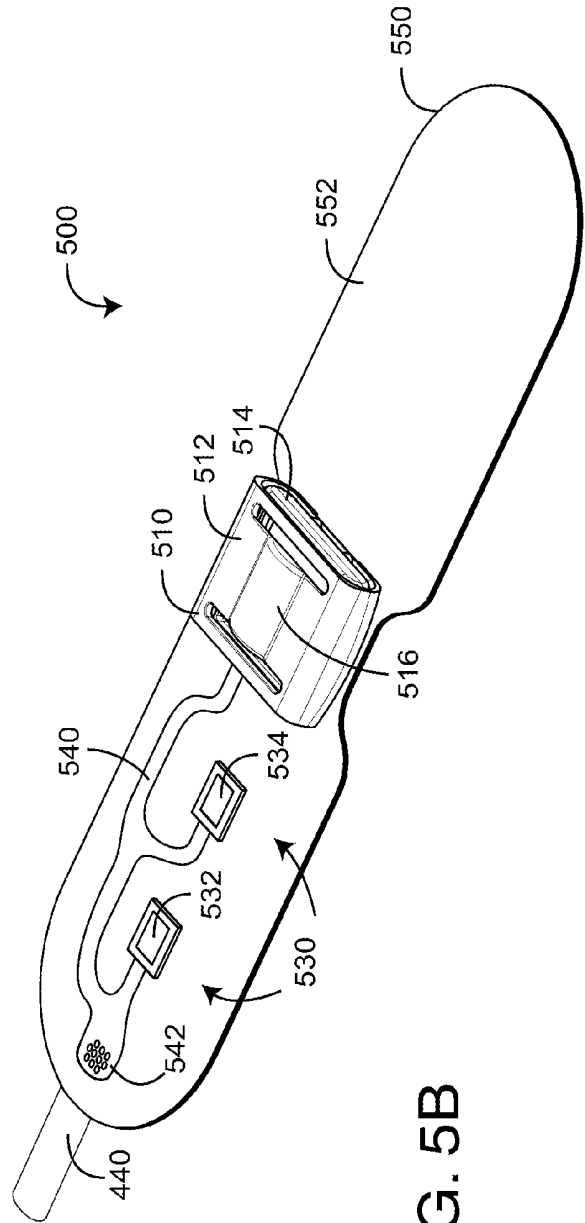

FIG. 5B

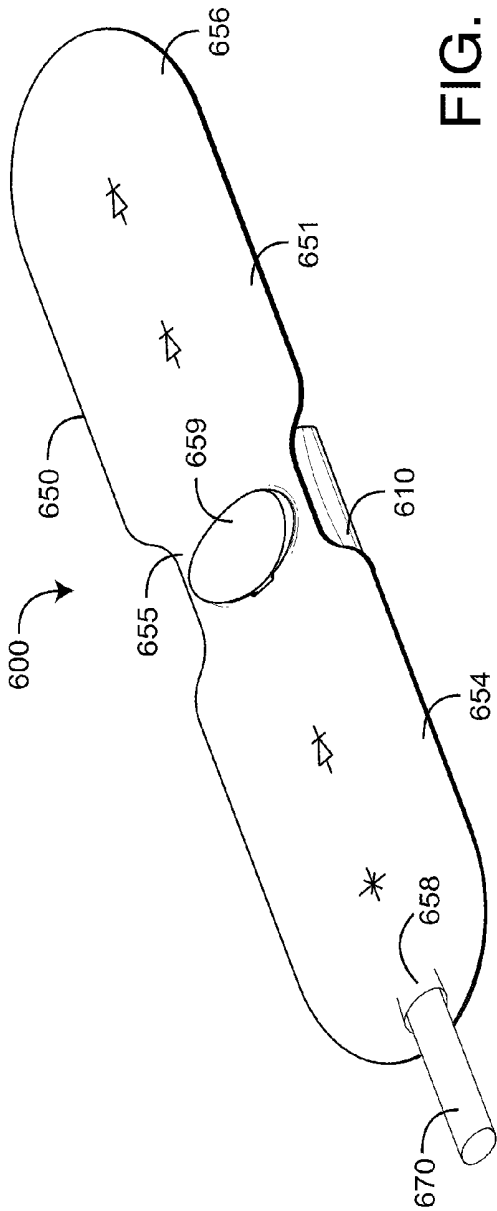

FIG. 6A

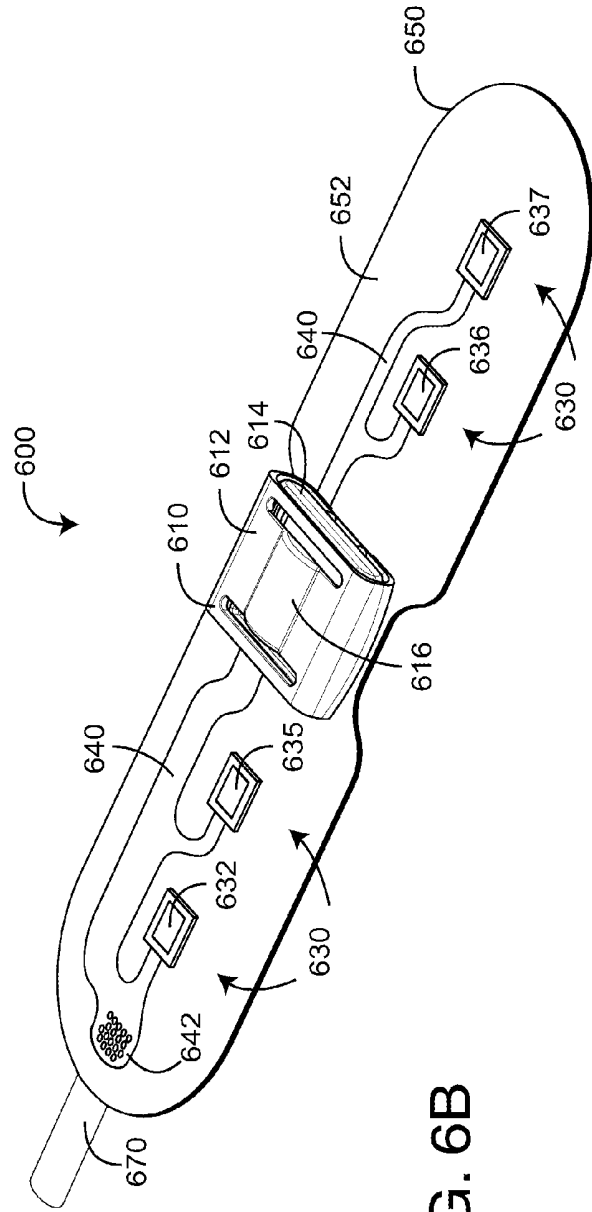
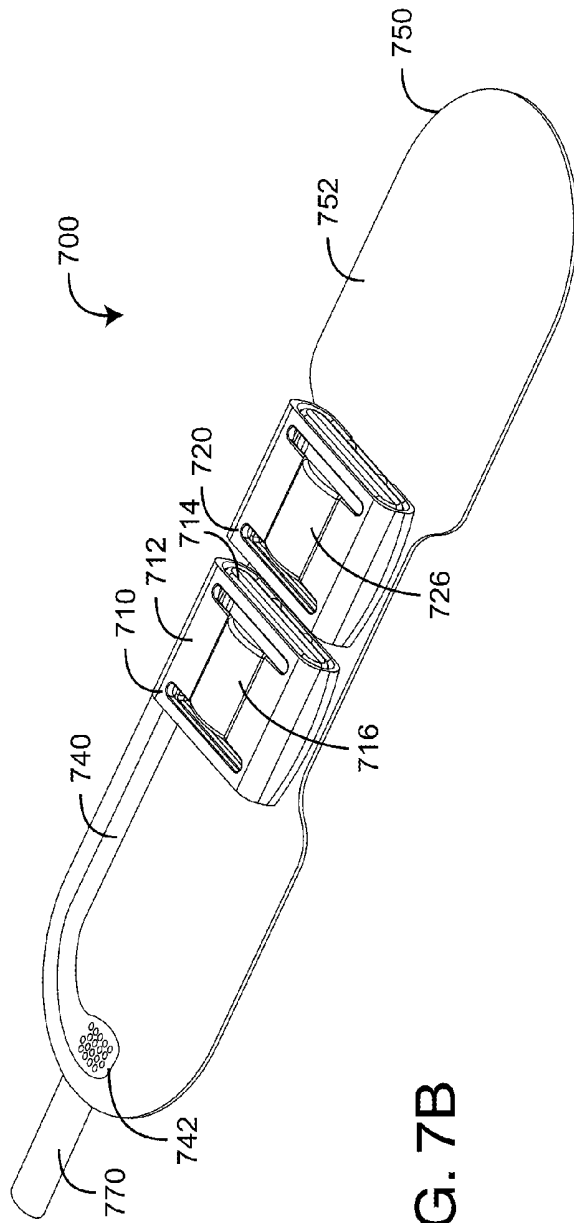
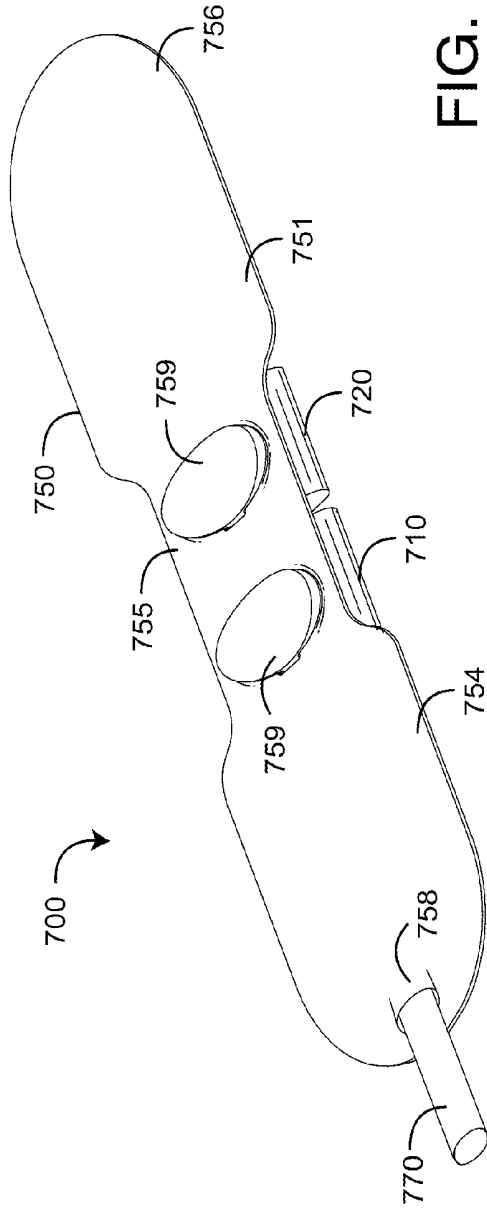

FIG. 6B



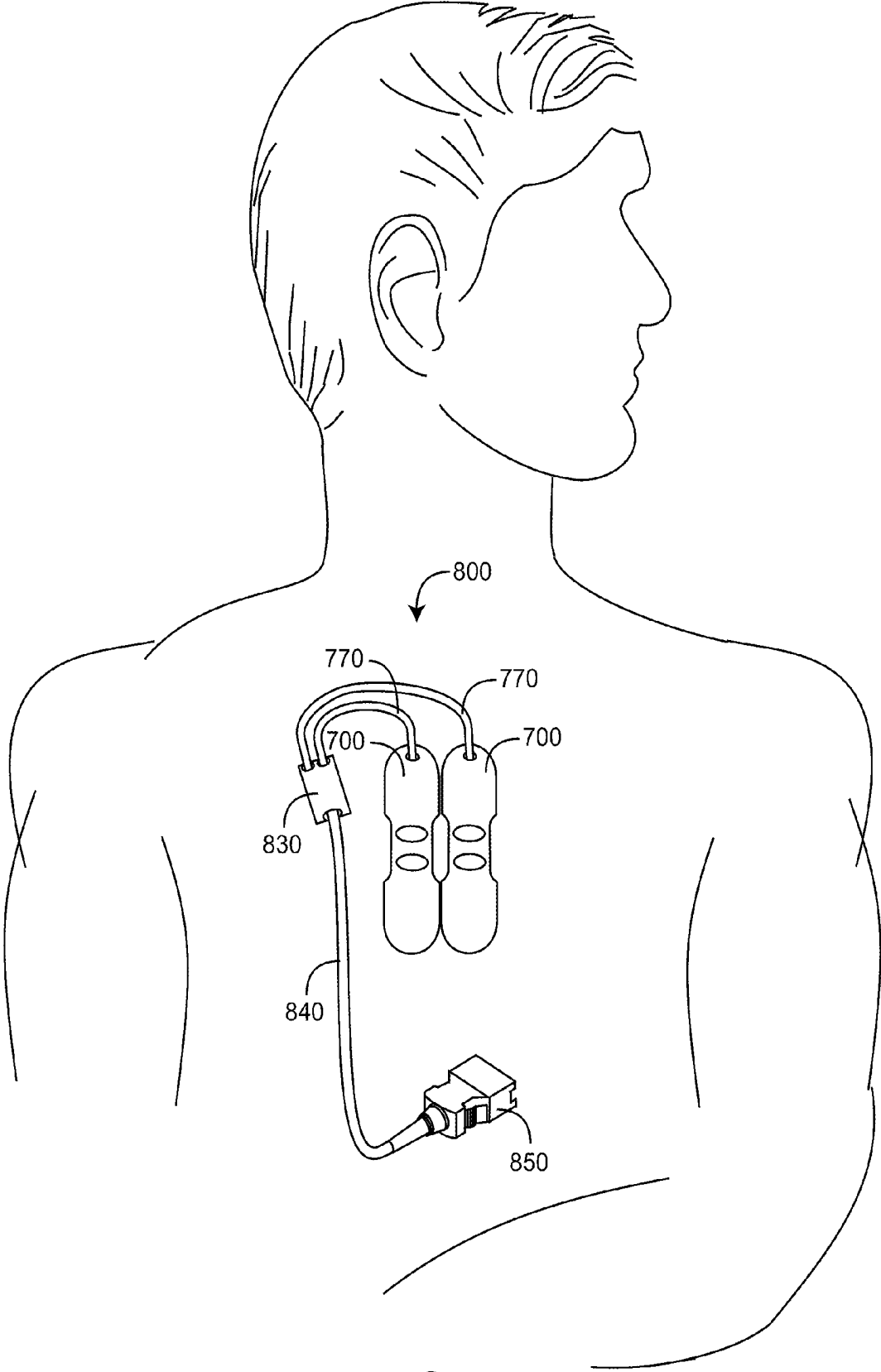

FIG. 8

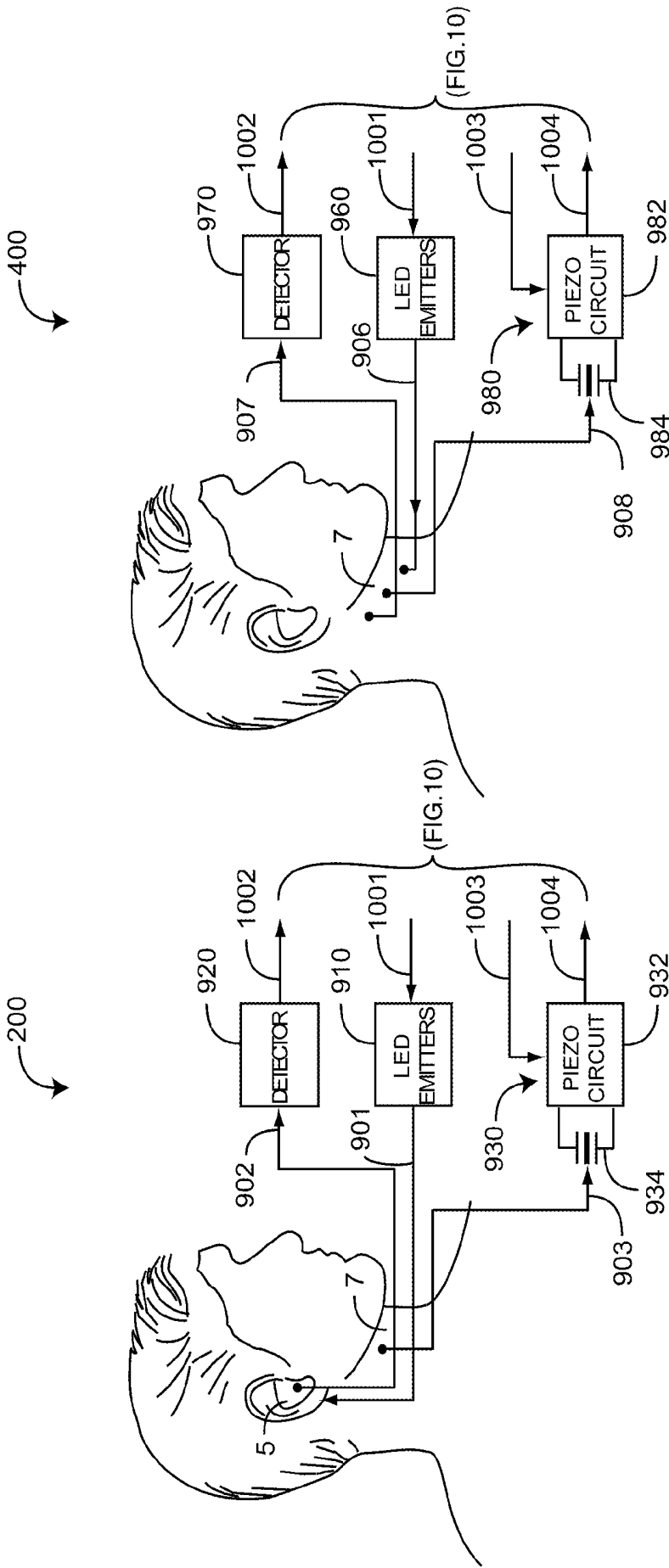

FIG. 9B

FIG. 9A

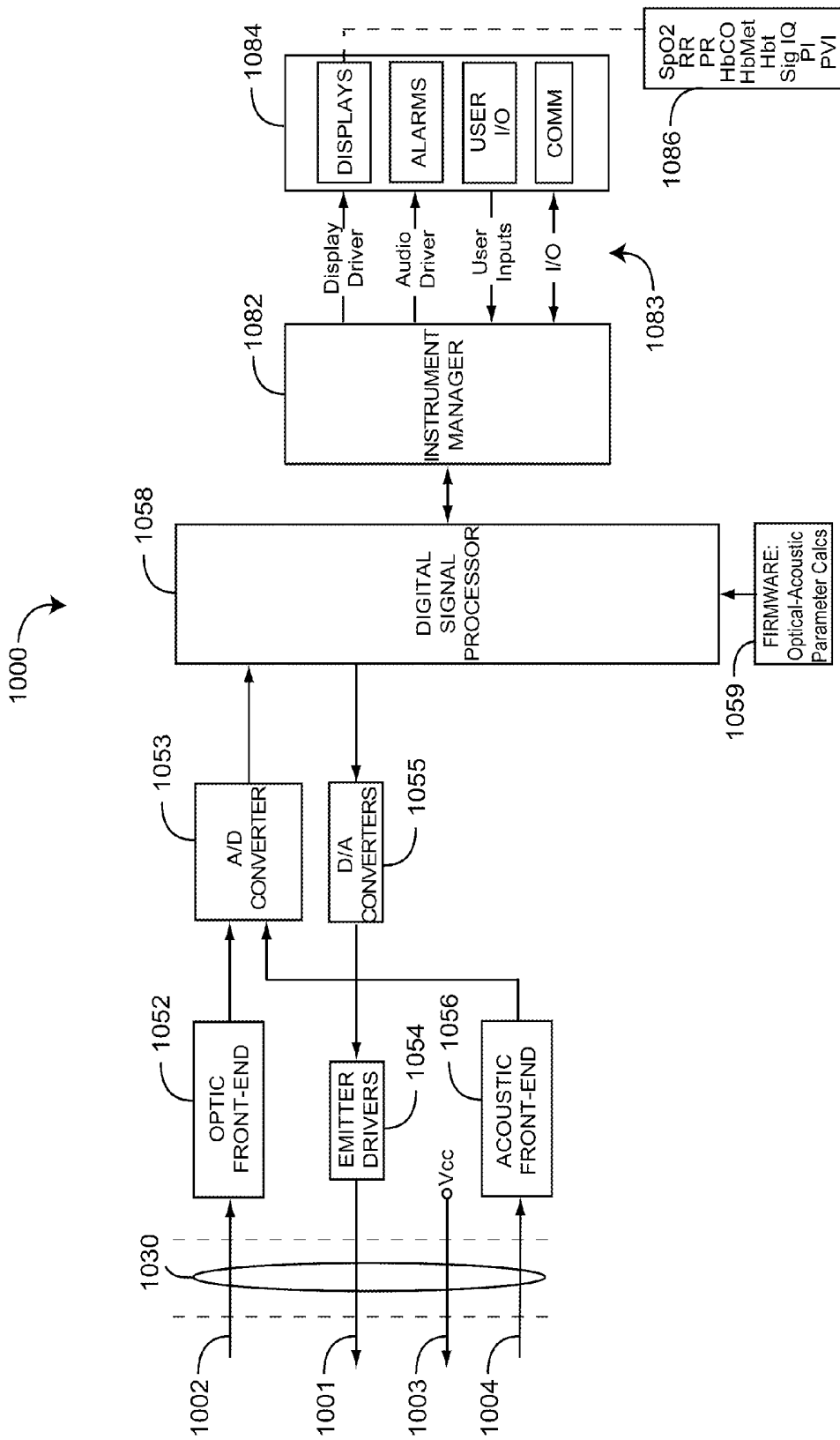

FIG. 10

OPTICOUSTIC SENSOR

INCORPORATION BY REFERENCE TO ANY
PRIORITY APPLICATIONS

This application claims priority benefit under 35 U.S.C. §120 from, and is a continuation of U.S. patent application Ser. No. 13/152,259, filed Jun. 2, 2011, entitled Opticoustic Sensor, which claims priority benefit under 35 U.S.C. §119 (e) from U.S. Provisional Patent Application Ser. No. 61/350,673, filed Jun. 2, 2010, entitled Opticoustic Sensor. Any and all applications for which a foreign or domestic priority claim is identified above or in the Application Data Sheet as filed with the present application are hereby incorporated by reference under 37 CFR 1.57.

BACKGROUND

Various sensors may be applied to a person for measuring physiological parameters indicative of health or wellness. As one example, a pulse oximetry sensor generates a blood-volume plethysmograph waveform from which oxygen saturation of arterial blood and pulse rate may be determined, among other parameters. As another example, an acoustic sensor may be used to detect airflow sounds in the lungs, bronchia or trachea, which are indicative of respiration rate.

SUMMARY

An optical-acoustic (“opticoustic”) sensor integrates an optic sensor for measuring blood flow parameters with an acoustic sensor for measuring body-sound parameters. Such integration increases the number of important physiological parameters available from a single sensor site or proximate sensor sites. Further, such integration allows improved measurements of physiological parameters.

In an advantageous embodiment, an opticoustic sensor applied to a neck site utilizes a piezo element to measure respiration rate acoustically (RRa), such as from trachea airflow sounds, and LEDs to measure respiration rate optically (RRo) from pulsatile blood flow. Such opticoustic-derived respiration rate (Roa) based upon both RRa and RRo provides a more accurate or more robust measure of respiration rate RR than achievable from either acoustic or optical sensors alone.

In an advantageous embodiment, a tissue-profile opticoustic sensor has an array of optical elements for distinguishing tissue depth. Applied to a neck site, the opticoustic sensor provides RRo, as described above, in addition to measurements of carotid oxygen saturation (SpO₂) and jugular (pulsatile) vein SpO₂ along with peripheral tissue SpO₂. The difference between carotid artery and jugular vein SpO₂ advantageously allows an indirect measure of brain oximetry parameters including brain oxygen demand and metabolism.

In an advantageous embodiment, a tissue-profile opticoustic sensor applied to a forehead site advantageously provides respiration parameters based upon paranasal sinus ostium airflow, turbulence and echoes and, further, cerebral oxygen saturation based upon pulsatile flow in blood-perfused brain tissues at various depths. Attached to a back or chest site, a tissue profile opticoustic sensor provides respiration parameters based upon turbulent airflow in the lungs and various airways along with neonatal core oxygen saturation.

Problems also arise when multiple sensors are used simultaneously for patient monitoring. Each sensor utilizes its

own cable and connector, and multiple sets of cables applied to different patient sites tend to tangle and rub together. This can cause electrical and acoustic noise, which affect the sensors and lead to inaccurate readings for measured parameters. Further, a patient tethered to a variety of cumbersome cables and connectors that limit patient movement may experience discomfort. In addition, it is inconvenient and time consuming for a caregiver to repeatedly connect and disconnect multiple cable sets between sensors and monitors.

In an advantageous embodiment, an integrated opticoustic sensor provides respiration rate based upon trachea airflow sounds and oxygen saturation and pulse rate based upon pulsatile blood flow within perfused ear tissues. In particular, proximate neck and ear site attachment embodiments measure oxygen saturation, pulse rate and respiration rate among other blood parameters. In addition, these major vital sign measurements can be taken with the attachment-detachment ease and convenience of a single sensor and with minimal patient discomfort.

BRIEF DESCRIPTION OF THE DRAWINGS

FIGS. 1A-B are illustrations of optical-acoustic (“opticoustic”) sensor embodiments in communications with an opticoustic monitoring platform;

FIG. 2 is an illustration of an opticoustic sensor embodiment for measurements of acoustically-derived parameters at a neck site and optically-derived parameters at a proximate ear site;

FIGS. 3A-B are illustrations of an opticoustic sensor embodiment for measuring acoustically-derived parameters at a neck site and optically-derived parameters at a distal ear site;

FIGS. 4A-B are illustrations of an opticoustic sensor embodiment for measuring acoustically-derived parameters and optically-derived parameters at a single tissue site, such as a neck or forehead;

FIGS. 5A-B are detailed top and bottom perspective views, respectively, of an opticoustic sensor head;

FIGS. 6A-B are detailed top and bottom perspective views, respectively, of a tissue-profile opticoustic sensor head;

FIGS. 7A-B are detailed top and bottom perspective views, respectively, of a multiple-acoustic sensor head;

FIG. 8 is an illustration of an arrayed acoustic sensor embodiment;

FIGS. 9A-B are detailed opticoustic sensor block diagrams; and

FIG. 10 is a detailed opticoustic monitor block diagram.

DETAILED DESCRIPTION

FIGS. 1A-B illustrate a patient monitoring system **100** having a monitor **1000** in communications with optical-acoustic (“opticoustic”) sensor embodiments **200**, **400**. As shown in FIG. 1A, an opticoustic sensor **200** attaches to a neck site so as to detect tracheal airflow sounds and an proximate ear site on a person so as to detect optical changes due to pulsatile flow in blood-perfused concha tissues, as described in detail with respect to FIGS. 2-3, below. An integrated sensor cable **240** links the sensor **200** to a patient cable **110**, and the patient cable **110** links the sensor cable **240** to the monitor **1000**, allowing communications between the sensor **200** and monitor **1000**, as described in detail with respect to FIG. 9A, below. The monitor **1000** processes the opticoustic sensor signals so as to calculate optically-derived

blood parameters from the optic head **210**, such as pulse rate (PR) and oxygen saturation (SpO₂), to name a few, and acoustically-derived parameters from the acoustic head **220**, such as respiration rate (RR), as described in detail with respect to FIG. **10**, below.

As shown in FIG. **1B**, in another embodiment, an opticoustic sensor **400** attaches to a single tissue site, such as a neck, forehead, chest or back, to name a few, so as to generate acoustic-based and optic-based sensor signals, as described in detail with respect to FIGS. **4-5**, below. An integrated sensor cable **440** links the sensor **400** to a monitor **1000** (FIG. **1A**) via a patient cable **110** (FIG. **1A**), as described in detail with respect to FIG. **98**, below. The monitor **1000** processes the opticoustic sensor signals so as to calculate acoustically-derived and optically-derived parameters from the integrated opticoustic sensor head **500**, as described in detail with respect to FIG. **10**, below.

In an advantageous embodiment, an opticoustic sensor **200** (FIG. **1A**), **400** (FIG. **1B**) utilizes a piezo element to measure respiration rate acoustically (RRa), such as from trachea airflow sounds, and LEDs to measure respiration rate optically (RRo) from pulsatile blood flow. Such opticoustic-derived respiration rate (Roa) based upon both RRa and RRo provides a more accurate or more robust measure of respiration rate RR than achievable from either acoustic or optical sensors alone. Optically-derived respiration rate RRo is described in U.S. patent application Ser. No. 13/076,423 titled Plethysmographic Respiration Processor filed Mar. 30, 2011, assigned to Masimo Corporation, Irvine, Calif. ("Masimo") and incorporated by reference herein.

Although capable of simultaneous optic and acoustic measurements at a single site, the opticoustic sensor **400** may also be advantageously used for optic measurements at one site and acoustic measurements at another site. For example, respiration rate may be monitored with the sensor head **500** attached to a neck site and cerebral oximetry may be monitored with the sensor head **500** attached to a forehead site.

Although described above with respect to respiration rate measurements, an opticoustic sensor **200**, **400** may provide acoustic-based parameters based upon any of various body sounds monitored at a variety of tissue sites, with applications ranging from cardiac function analysis and diagnosis to acoustic rhinometry. Likewise, optic-based parameters may be based on blood flow monitored at a variety of tissue sites.

FIG. **2** illustrates an opticoustic sensor embodiment **200** providing respiration rate based upon trachea airflow sounds in addition to oxygen saturation and pulse rate measurements based upon pulsatile blood flow in ear tissues. The opticoustic sensor **200** has an acoustic head **220** configured for a neck site **7** and an optic head **210** configured for an ear concha site **5** proximate to the neck site **7**, i.e. on the same side of the head as the neck site **7**. Advantageously, the proximate ear site **5** and neck site **7** allows the sensor to be applied and removed with the ease and convenience of a single site sensor. An optic head cable **212** interconnects the optic head **210** to a sensor cable **240**. An acoustic head cable **222** interconnects the acoustic head **220** to the sensor cable **240**. An anchor **230** attaches to the patient's neck so as to stabilize the cables **212**, **222**, **240** and prevent rubbing and movement that might generate mechanical and/or electrical noise, which interferes with the sensor signal. Advantageously, the two sensor heads **210**, **220** provide complementary physiological measurements, with the acoustic head **220** providing respiration rate based upon trachea airflow sounds and the optic head **210** providing oxygen saturation and pulse rate measurements, among others, based upon pulsa-

tile blood flow in perfused ear (concha) tissues. The sensor cable **240** communicates between the opticoustic sensor **200** and a patient monitor **1000** (FIG. **1A**) via a sensor cable connector **250**. The opticoustic sensor output can be processed by a single monitoring platform sharing common signal processing hardware, as described with respect to FIG. **10**, below.

As shown in FIG. **2**, one embodiment of the optic head **210** is a "Y"-clip having a base, a pair of curved clips extending from the base, an emitter assembly extending from one clip end and a detector assembly extending from another clip end. The clips are tubular so as to accommodate wires from the emitter/detector assemblies, which extend from apertures in the base. Each assembly has a pad, a molded lens and a lid, which accommodate either an emitter subassembly or a detector subassembly. The Y-clip flexes so as to slide over the ear periphery and onto either side of the concha. The Y-clip, so placed, can transmit multiple wavelength light into the concha tissue and detect that light after attenuation by pulsatile blood flow within the concha tissue. Ear sensor embodiments are described in U.S. patent application Ser. No. 12/706,711, titled Ear Sensor, filed Feb. 16, 2010, assigned to Masimo and incorporated by reference herein.

In an embodiment, the Y-clip emitter includes both a red light emitting diode (LED) and an infrared (IR) LED. The detector is a photodiode that responds to both the red and infrared emitted light so as to generate an output signal to the monitor. The LEDs emit light into the ear concha. The photodiode is positioned opposite the emitters so as to detect the LED emitted light after attenuation by the blood-perfused concha tissue. The emitter and detector have pinouts to the connector **250**, which provides sensor communication with the monitor. The monitor determines oxygen saturation by computing the differential absorption by arterial blood of the two wavelengths of emitted light, as is well-known in the art. Although described above with respect to a Y-clip attached to an ear concha site, the optic head **210** may comprise any of a variety of transmission-mode or reflectance-mode sensors attached to various ear tissue sites, such as an ear lobe or an ear canal, as described in U.S. patent application Ser. No. 12/706,711, cited above.

Also shown in FIG. **2**, one embodiment of the acoustic head **220** is an attachment assembly configured to hold a sensor assembly in contact with a neck site **7**. The attachment assembly has lateral extensions symmetrically placed about a sensor assembly, which has a piezoelectric membrane mounted in a support frame. The piezoelectric membrane moves on the frame in response to acoustic vibrations, thereby generating electrical signals indicative of the bodily sounds of the patient. An acoustic coupler generally envelops the other sensor elements and improves the coupling between the neck skin and the piezoelectric membrane. Acoustic sensor embodiments, including embodiments of attachment subassemblies and piezoelectric transducer subassemblies thereof, are described in U.S. patent application Ser. No. 12/643,939 titled Acoustic Sensor Assembly, filed Dec. 21, 2009 and U.S. patent application Ser. No. 12/904,789 titled Acoustic Respiratory Monitoring Systems and Methods, filed Oct. 14, 2010, both patent applications assigned to Masimo and both incorporated by reference herein.

FIGS. **3A-B** illustrate an opticoustic sensor embodiment **300** providing respiration rate based upon trachea airflow sounds in addition to oxygen saturation and pulse rate measurements based upon pulsatile blood flow in ear tissues. The opticoustic sensor **300** has an acoustic head **320** con-

figured for a neck site 7 (FIG. 3A) and an optic head 310 configured for an ear concha site 9 (FIG. 38) distal to the neck site 7 (FIG. 3A), i.e. on the opposite side of the head. The opticoacoustic sensor 300 has an optic head 310 configured for an ear concha site 9 and an acoustic head 320 configured for a neck site 7. Advantageously, the neck site 7 and distal ear site 9 removes the optic head cable 312 and the sensor cable 340 from proximity to the acoustic head 320, eliminating any potential for movement of these cables 312, 340 from creating acoustic noise that could interfere with the acoustic head 320. An optic head cable 312 interconnects the optic head 310 to a sensor cable 340. An acoustic head cable 322 routes behind a patient neck so as to interconnect the acoustic head 320 to the sensor cable 340. An anchor 330 attaches to the patient's neck so as to stabilize the optical and acoustic head cables 312, 322 and the interconnecting sensor cable 340. The sensor cable 340 communicates between the opticoacoustic sensor 300 and a patient monitor 1000 (FIG. 1A) via a sensor cable connector 350. The opticoacoustic sensor output can be processed by a single monitoring platform sharing common signal processing hardware, as described with respect to FIG. 10, below.

FIGS. 4A-B illustrate an opticoacoustic sensor embodiment 400 providing respiration-related parameters based upon airflow sounds in addition to pulsatile blood flow-related parameters, such as pulse rate and oxygen saturation. The opticoacoustic sensor 400 has a sensor head 500, a sensor cable 440, a cable anchor 430 and a sensor cable connector 450. The sensor head 500 advantageously integrates both an optic assembly and an acoustic assembly into an integrated adhesive media that can be quickly and easily applied to a neck site 7 or a forehead site 3, to name a few, so as to measure a wide range of physiological parameters. The sensor cable 440 communicates sensor signals and monitor control signals between the sensor head 500 and the sensor connector 450. The sensor connector 450 mates with a patient cable 110 (FIG. 1A) or directly with a patient monitor 1000 (FIG. 1A). The optic and acoustic assemblies are described in further detail with respect to FIGS. 5-6, below.

FIGS. 5A-B illustrates a sensor head 500 for an opticoacoustic sensor embodiment 400 (FIGS. 4A-B). The sensor head 500 has acoustic 510, optic 530, interconnect 540 and attachment 550 assemblies. The acoustic assembly 510 has an acoustic coupler 512 and a piezoelectric subassembly 514. The acoustic coupler 512 generally envelops or at least partially covers some or all of the piezoelectric subassembly 512. The piezoelectric subassembly 512 includes a piezoelectric element and a support frame (not visible). The piezoelectric membrane is configured to move on the frame in response to acoustic vibrations, thereby generating electrical signals indicative of the bodily sounds of the patient. The acoustic coupler 512 advantageously improves the coupling between the acoustic signal measured at the patient's skin and the piezoelectric element. The acoustic coupler 512 includes a contact portion 516, which is brought into contact with the skin of the patient. As an example, at a neck site the acoustic assembly is responsive to tracheal air flow sounds that can yield a patient's respiration rate.

As shown in FIG. 5B, the optic assembly 530 has an emitter subassembly 532 and a detector subassembly 534. The emitter subassembly 532 includes multiple light emitting diodes and/or laser diodes (collectively "LEDs") that emit narrow bandwidth light centered on at least two discrete wavelengths in the red and IR spectrums. The LEDs may be mounted on the attachment assembly 550 or mounted remotely, such in the sensor cable connector 450 (FIGS. 4A-B) or the monitor 1000 (FIG. 1A). If mounted

remotely, light output from the LEDs may be transported via optical fibers to the emitter subassembly 532. The detector subassembly 534 includes at least one photodiode detector and has a response bandwidth that includes all of the emitter subassembly 532 bandwidths. In an embodiment, the emitter subassembly 532 includes an addressable, monolithic LED array that is mechanically mounted and electrically interconnected in an encapsulated cavity of a ceramic substrate. In an embodiment, the detector subassembly 534 includes a monolithic Si photodiode or a combination of a monolithic Si photodiode and a monolithic InGaAs photodiode mechanically mounted and electrically interconnected in an encapsulated and electromagnetically shielded cavity of a ceramic substrate. The optical assembly 530 is configured so that light transmitted from the emitter 532 passes into patient tissue and is reflected back to the detector 534 after attenuation by pulsatile blood flow in the tissue.

Further shown in FIG. 5B, the acoustic assembly 510 and optic assembly 530 communicate with the sensor cable 440 via the interconnect assembly 540. In an embodiment, the interconnect assembly 540 is a flex circuit having multiple conductors that is adhesively bonded to the attachment assembly 550. The interconnect assembly 540 has a solder pad 542 or other interconnect to interface with the sensor cable 440, and the attachment assembly 550 has a molded strain relief 558 for the sensor cable 440. In an embodiment, the attachment assembly 550 is a generally elongated, planar member having a top side 551, a bottom side 552, a first wing 554, a center 555 and a second wing 556. A button 559 mechanically couples the acoustic assembly 510 to the attachment assembly center 555 so that the acoustic assembly 510 extends from the bottom side 552.

Also shown in FIG. 5B, the optic assembly 530 is disposed on the attachment assembly bottom side 552 at the first wing 554. In other embodiments, the optic assembly 530 is disposed on the second wing 556 or both wings 554, 556. The interconnect assembly 540 routes along the bottom side 552 (as shown) or otherwise within and/or upon the attachment assembly 550 so as to interconnect the acoustic 510 and optical 530 assemblies. The sensor cable 440 extends from one end of the interconnect 540 and attachment assemblies 550 to a sensor connector 450 (FIGS. 4A-8) at an opposite end so as to provide communications between the sensor 500 and a monitor 1000 (FIG. 1A), as described in further detail with respect to FIG. 9B, below. In an embodiment, the wings 554, 556 have an adhesive along the bottom side 552 so as to secure the acoustic 510 and optic 530 assemblies to a patient's skin, such as at a neck site 7 (FIG. 4A). A removable backing can be provided with the adhesive to protect the adhesive surface prior to affixing to a patient's skin. In other embodiments, the attachment assembly 550 has a circular or rounded shape, which advantageously allows uniform adhesion of the sensor head 500 to a measurement site. In a resposable embodiment, the attachment assembly 550 or portions thereof are removably attachable/detachable to the acoustic assembly 510, the optic assembly 530 or both and disposed. The acoustic 510 and/or optic 530 assemblies are reusable accordingly.

FIGS. 6A-8 illustrates a tissue-profile sensor head 600 having acoustic 610, optic 630, interconnect 640 and attachment 650 assemblies and a sensor cable 670. The acoustic assembly 610 is as described above with respect to 510 (FIGS. 5A-B). The optic assembly 630 has an emitter subassembly 632 and multiple detector subassemblies 635-637. The emitter subassembly 632 and each of the detector subassemblies 635-637 are as described above with respect to 532, 534 (FIG. 5B).

Advantageously, the optic assembly 630 is configured so that light transmitted from the emitter subassembly 632 passes into patient tissue and is reflected back to the detector subassemblies 635-637 after attenuation by pulsatile blood flow. Further, the tissue-attenuated light detected varies according to tissue depth and the spacing between the emitter subassembly 632 and a particular one of the detector subassemblies 635-637. Accordingly, the multiple detector subassemblies advantageously provide a tissue profile of SpO₂ versus depth. Specifically, simultaneous SpO₂ measurements are made at various tissue depths so as to distinguish blood-perfused surface tissue measurements from deeper tissues, veins and arteries.

As shown in FIGS. 6A-B, the acoustic assembly 610 and optic assembly 630 communicate with the sensor cable 670 via the interconnect assembly 640. In an embodiment, the interconnect assembly 640 is a flex circuit having multiple conductors that is adhesively bonded to the attachment assembly 650. The interconnect assembly 640 has a solder pad 642 or other interconnect to interface with the sensor cable 670, and the attachment assembly 650 has a molded strain relief 658 for the sensor cable 670. In an embodiment, the attachment assembly 650 is a generally elongated, planar member having a top side 651, a bottom side 652, a first wing 654, a center 655 and a second wing 656. A button 659 mechanically couples the acoustic assembly 610 to the attachment assembly center 655 so that the acoustic assembly 610 extends from the bottom side 652.

Also shown in FIGS. 6A-B, the optic assembly 630 is disposed on the attachment assembly bottom side 652 along the first wing 654 and second wing 656. The interconnect assembly 640 routes along the bottom side 652 (as shown) or otherwise within and/or upon the attachment assembly 650 so as to interconnect the acoustic 610 and optical 630 assemblies. The sensor cable 670 extends from one end 642 of the interconnect assembly 640 and the attachment assembly 650 to a sensor connector 450 (FIGS. 4A-B) at an opposite end so as to provide communications between the sensor 600 and a monitor 1000 (FIG. 1A). The attachment assembly 650 is as described in detail above with respect to 550 (FIGS. 5A-B).

An advantageous application of a tissue-profile sensor head 600 is placement on a neck site 7 (FIG. 4A) so as to measure respiration parameters based upon tracheal airflow sounds, such as respiration rate, and so as to measure blood-related parameters based upon pulsatile blood flow within peripheral (surface) tissues, within the common carotid artery (CCA) and/or the jugular vein (JV), such as pulse rate and SpO₂. The CCA and JV are close to the neck skin surface and large in size, so as to facilitate optical reflectance measurements. Further, the CCA and JV supply and extract most of the blood to and from the brain and can therefore yield information regarding cerebral oxygen demand and corresponding metabolic rate parameters.

In a further advantageous embodiment of a tissue-profile sensor head 600, the acoustic assembly 610 and, in particular, the piezoelectric transducer subassembly or subassemblies thereof is configured to generate an active pulse into the tissue site so as to measure venous oxygen saturation (SpvO₂) and other blood constituents of the peripheral neck tissues. The use of an active pulse for blood constituent measurements is described in U.S. Pat. No. 5,638,816 titled Active Pulse Blood Constituent Monitoring, filed Jun. 7, 1995; and U.S. Pat. No. 6,334,065 titled Stereo Pulse Oximeter, filed May 27, 1999, both patents assigned to Masimo and both incorporated by reference herein. Transmitting acoustic vibrations into a tissue measurement site

with an acoustic sensor and, in particular, the piezoelectric acoustic sensing element thereof by applying a relatively high voltage driver to the piezoelectric element is describe in U.S. patent application Ser. No. 12/904,789 titled Acoustic Respiratory Monitoring Systems and Methods, cited above.

In a particularly advantageous embodiment, an optico-acoustic sensor such as a tissue-profile sensor head 600 described above, when placed on the neck, has one or more acoustic sensor assemblies for measuring respiration rate acoustically (RRa) and one or more optical sensor assemblies for measuring respiration rate optically (RRo) so as to provide a more accurate measure of respiration rate; and the same optical sensor assemblies for measuring carotid artery SpO₂, jugular vein SpO₂, and peripheral tissue SpO₂; and a combination of the same acoustic and optical sensor assemblies for measuring peripheral tissue venous oxygen saturation SpvO₂. Similar advantageous combined use of the acoustic and optical sensor assemblies of an optico-acoustic sensor may be obtained by attaching the tissue-profile sensor head 600, singularly or in multiple combinations of sensor heads, on various tissue sites of the body.

Another advantageous application of a tissue-profile sensor head 600 is placement on a forehead site 3 (FIG. 4B) so as to provide respiration parameters based upon paranasal sinus ostium airflow, turbulence and echoes and, further, cerebral oxygen saturation based upon pulsatile flow in blood-perfused brain tissues at various depths. Attached to a back or chest site, a tissue profile sensor head 600 provides respiration parameters based upon turbulent airflow in the lungs and various airways along with neonatal core oxygen saturation.

In addition, a dual-head sensor, such as described with respect to FIG. 8, below, allows placement of one sensor head 600 at a neck site 7 (FIG. 4A) and another sensor head 600 at a forehead site 3 (FIG. 4B) so as to provide simultaneous oxygen saturation measurements of the CCA, brain tissue at various depths and the JV. Such simultaneous measurements provide an overall functional analysis of cerebral oxygen supply and metabolism along with a comprehensive diagnostic tool for cerebral injury and disease.

FIGS. 7A-B illustrate a multiple-acoustic sensor head 700 having a first acoustic assembly 710, a second acoustic assembly 720, an interconnect assembly 740, attachment assembly 750 and a sensor cable 770. Each acoustic assembly 710, 720 has an acoustic coupler 712 and a piezoelectric subassembly 714 including contact portions 716, 726 as described with respect to FIGS. 5A-B, above. The acoustic assemblies 710, 720 communicate with the sensor cable 770 via the interconnect assembly 740. In an embodiment, the interconnect assembly 740 is a flex circuit having multiple conductors that is adhesively bonded to the attachment assembly 750. The interconnect assembly 740 has a solder pad 742 or other interconnect so as to interface with the sensor cable 770, and the attachment assembly 750 has a molded strain relief 758 for the sensor cable 770. The attachment assembly 750 is a generally elongated, planar member having a top side 751, a bottom side 752, a first wing 754, a center 755 and a second wing 756. Buttons 759 mechanically couple the acoustic assemblies 710, 720 to the attachment assembly center 755 so that the acoustic assemblies 710, 720 extend from the bottom side 752. In an embodiment, the sensor head 700 may have an optical assembly such as described with respect to FIGS. 5A-B or FIGS. 6A-B, above.

In an advantageous embodiment, one of the acoustic assemblies 710, 720 is optimized for measuring pulse rate

and heart sounds from the heart and the other one of the acoustic assemblies **710**, **720** is optimized for separately measuring turbulent air sounds from the lungs and various airways. Heart sounds typically range in frequency from about 15 Hz-400 Hz and are relatively narrow band. By contrast, lung sounds typically range from about 600 Hz-2000 Hz and resemble broadband white-noise. Accordingly, in one embodiment, one of the piezo circuits **982** (FIG. **9B**) of the acoustic assemblies **710**, **720** is optimized for heart sounds and the other one of the piezo circuits **982** (FIG. **9B**) is optimized for lung sounds.

An opticoustic sensor head **700** may be applied singly to a neck site, as described with respect to FIG. **18**, above, or to other sites including the chest or back. Further, multiple identical sensor heads **700** may be used in combination with a common cable in an arrayed sensor head embodiment, as described with respect to FIG. **8**, below

FIG. **8** illustrates an arrayed acoustic sensor **800** embodiment that advantageously accesses the spatial information contained in thoracic sounds. The arrayed acoustic sensor **800** has two or more multiple-acoustic sensor heads **700**, head cables **770**, a cable junction **830**, a sensor cable **840** and a sensor connector **850**. Each of the sensor heads **700** have multiple acoustic transducers, as described with respect to FIGS. **7A-B**, above. The arrayed acoustic sensor **800** is responsive to both the direction and timing of body sounds. Such a configuration allows a continuous visualization of breath sound information during a complete breathing cycle, details regarding breath sound timing between the different lung locations and a quantification of the regional distribution of breath sounds. Although described with respect to FIGS. **7A-8**, above, as having two acoustic transducers in each sensor head **700**, an arrayed acoustic sensor **800** may have three or more acoustic transducers in each sensor head. Further, there may be three or more sensor heads **700** merged via the cable junction **830** into the sensor cable **840**. In addition, two or more heads may be merged onto a single attachment assembly having sufficient size for both rows and columns of acoustic transducers. The merged assembly shares a single sensor cable **840**, which eliminates the sensor junction **830**. The arrayed acoustic sensor **800** may be attached at various neck, chest and back sites. Further, multiple arrayed opticoustic sensors **800** may be attached at multiple sites, such as chest, neck and back areas, and routed to a single monitor for analysis.

FIG. **9A** illustrates an opticoustic sensor **200** embodiment according to FIGS. **2-3** having an optic head **210** (FIG. **2**) and an acoustic head **220** (FIG. **2**). The optic head **210** (FIG. **2**) has LED emitters **910** attached on one side of an ear concha site **5** and at least one detector **920** attached on the opposite side of the concha site **5**. In an embodiment, the emitters **910** emit light **901** having at least one red wavelength and at least one IR wavelength, so as to determine a ratio of oxyhemoglobin and deoxygemoglobin in the pulsatile blood perfused tissues of the concha. In other embodiments, the emitters **910** generate light having more than two discrete wavelengths so as to resolve other hemoglobin components. Emitter drivers in the monitor **1000** (FIG. **10**) activate the emitters **910** via drive lines **1001** in the sensor cables **110** (FIGS. **1A-B**). The detector **920** generates a current responsive to the intensity of the received light **902** from the emitters **910** after attenuation by the pulsatile blood perfused concha tissue **5**. One or more detector lines **1002** in the sensor cables **110** (FIGS. **1A-B**) transmit the detector current to the monitor **1000** (FIG. **10**) for signal conditioning and processing, as described with respect to FIG. **10**, below.

Also shown in FIG. **9A**, the acoustic head **220** (FIG. **2**) has an acoustic sensor **930** attached to a neck site **7**. The acoustic sensor **930** has a power interface **1003**, a piezo circuit **932** and a piezoelectric element **934**. The piezoelectric element **934** senses vibrations and generates a voltage in response to the vibrations, as described with respect to the various sensor embodiments, above. The signal generated by the piezoelectric element **934** is communicated to the piezo circuit **932**, described immediately below, and transmits the signal **1004** to the monitor **1000** (FIG. **10**) for signal conditioning and processing.

The piezo circuit **932** decouples the power supply and performs preliminary signal conditioning. In an embodiment, the piezo circuit **932** includes clamping diodes to provide electrostatic discharge (ESD) protection and a mid-level voltage DC offset for the piezoelectric signal to ride on, to be superimposed on or to be added to. The piezo circuit **932** may also have a high pass filter to eliminate unwanted low frequencies such as below about 100 Hz for breath sound applications, and an op amp to provide gain to the piezoelectric signal. The piezo circuit **932** may also have a low pass filter on the output of the op amp to filter out unwanted high frequencies. In an embodiment, a high pass filter is also provided on the output in addition to or instead of the low pass filter. The piezo circuit **932** may also provide impedance compensation to the piezoelectric element **934**, such as a series/parallel combination used to control the signal level strength and frequency of interest that is input to the op amp. In one embodiment, the impedance compensation is used to minimize the variation of the piezoelectric element output. The impedance compensation can be constructed of any combination of resistive, capacitive and inductive elements, such as RC or RLC circuits.

FIG. **9B** illustrates an opticoustic sensor **400** embodiment according to FIGS. **4-5** having an integrated sensor with both optic and acoustic assemblies that attach along a neck site **7**, as but one example. The optic assembly has LED emitters **960** and at least one detector **970** spaced apart at a predetermined distance. In an embodiment, the LEDs **960** emit light **906** having at least one red wavelength and at least one IR wavelength, so as to determine a ratio of oxyhemoglobin and deoxygemoglobin in pulsatile blood perfused tissue. In other embodiments, the LEDs **960** generate light having more than two discrete wavelengths so as to resolve other hemoglobin components. Emitter drivers in the monitor **1000** (FIG. **10**) activate the emitters **960** via drive lines **1001** in the sensor and patient cables. The detector **970** generates a current responsive to the intensity of the received light **907** from the emitters **960** after reflection/attenuation by pulsatile blood perfused tissue. One or more detector lines **1002** transmit the detector current to the monitor **1000** (FIG. **10**) for signal conditioning and processing, as described with respect to FIG. **10**, below. Also shown in FIG. **9B**, the acoustic assembly has an acoustic sensor **980** attached to, as but one example, a neck site **7**. The acoustic sensor **980** has a power interface **1003**, a piezo circuit **982** and a piezoelectric element **984**, as described above with respect to FIG. **9A**.

In multiple acoustic transducer embodiments, the piezo circuit **982** for one transducer is optimized for pulse and heart sounds and the piezo circuit **982** for another transducer is optimized for lung sounds. In an embodiment, a piezo circuit filter is relatively broadband and has a relatively high center frequency for lung/breath sounds and is relatively narrow band with a relatively low center frequency for pulse and heart sounds. In a particularly advantageous embodiment, acoustic-derived pulse and heart sounds are used to

verify an optically-derived pulse rate as well as characteristics of plethysmograph waveforms.

FIG. 10 illustrates a monitor 1000 for driving and processing signals from an opticoustic sensor 200, 400 (FIGS. 9A-B). The monitor 1000 includes an optical front-end 1052, an acoustic front-end 1056, an analog-to-digital (A/D) converter 1053, a digital signal processor (DSP) 1058, emitter drivers 1054 and digital-to-analog (D/A) converters 1055. In general, the D/A converters 1055 and drivers 1054 convert digital control signals into analog drive signals 1001 capable of activating the emitters 910, 960 (FIGS. 9A-B) via a sensor cable 1030. The optical front-end 1052 and A/D converter 1053 transform composite analog intensity signal(s) from light sensitive detector(s) received via the sensor cable 1030 into digital data input to the DSP 1058. The acoustic front-end 1056 and A/D converter 1053 transform analog acoustic signals from a piezoelectric element into digital data input to the DSP 1058. The A/D converter 1053 is shown as having a two-channel analog input and a multiplexed digital output to the DSP 1058. In another embodiment, each front-end 1052, 1056 communicates with a dedicated single channel ND converter generating two independent digital outputs to the DSP 1058.

According to an embodiment, the DSP 1058 comprises a processing device based on the Super Harvard Architecture ("SHARC"), such as those commercially available from Analog Devices. However, the DSP 1058 can comprise a wide variety of data and/or signal processors capable of executing programs 1059 for determining physiological parameters from input data.

Also shown in FIG. 10, an instrument manager 1082 communicates with the DSP 1058 to receive physiological parameter information derived by the DSP firmware 1059. One or more I/O devices 1084 have communications 1083 with the instrument manager 1082 including displays, alarms, user I/O and instrument communication ports. The alarms may be audible or visual indicators or both. The user I/O may be, as examples, keypads, touch screens, pointing devices or voice recognition devices, to name a few. The displays may be indicators, numerics or graphics for displaying one or more of various physiological parameters 1086. The instrument manager 1082 may also be capable of storing or displaying historical or trending data related to one or more of the measured values or combinations of the measured values. A patient monitor is disclosed in U.S. application Ser. No. 11/367,033, filed on Mar. 1, 2006, titled Noninvasive Multi-Parameter Patient Monitor, which is assigned to Masimo and incorporated by reference herein.

In various embodiments, the monitor 1000 may be one or more processor boards installed within and communicating with a host instrument. Generally, a processor board incorporates the front-end 1052, 1056, drivers 1054, converters 1053, 1055 and DSP 1058. Accordingly, the processor board derives physiological parameters and communicates values for those parameters to the host instrument. Correspondingly, the host instrument incorporates the instrument manager 1082 and I/O devices 1084. A processor board may also have one or more microcontrollers (not shown) for board management, including, for example, communications of calculated parameter data and the like to the host instrument.

An opticoustic sensor has been disclosed in detail in connection with various embodiments. These embodiments are disclosed by way of examples only and are not to limit the scope of the claims that follow. One of ordinary skill in art will appreciate many variations and modifications.

What is claimed is:

1. A physiological sensor comprising:
 - an optic assembly comprising an optic transducer;
 - an acoustic assembly comprising an acoustic transducer;
 - an attachment assembly configured to affix the optic assembly and acoustic assembly to a tissue site at a neck of a patient, the attachment assembly comprising:
 - an elongated body comprising a first section including a first wing of the elongated body, a second section including a second wing opposite the first end of the elongated body, and a third section between the first wing and the second wing, the third section including a center of the elongated body, the first wing having a length greater than a width, wherein the width of the first wing adjoins the first wing to the third section, the first wing extending in a first direction away from the third section and the second wing having a length greater than a width, wherein the width of the second wing adjoins the second wing to the third section, the second wing extending in a second direction, opposite the first direction, away from the third section;
 - wherein the acoustic assembly is affixed to the third section and the optic assembly is affixed to the first wing;
 - the optic transducer configured to transmit a plurality of wavelengths of light into the tissue site and detect the light after attenuation by pulsatile blood flow within the tissue site so as to generate an optic signal;
 - the acoustic transducer configured to respond to vibrations at the surface of the tissue site so as to generate an acoustic signal; and
 - a sensor cable configured to transmit the optic signal and the acoustic signal, the sensor cable further configured to connect to a monitor configured to calculate a plurality of physiological parameters based on the transmitted optic and acoustic signals.
2. The physiological sensor according to claim 1 wherein the elongated body comprises:
 - a bottom side and a top side; the bottom side having an adhesive for skin attachment.
3. The physiological sensor according to claim 2 wherein the optic assembly comprises:
 - a plurality of emitters that transmit light having a plurality of wavelengths in response to drive current received from the monitor via the sensor cable;
 - a detector responsive to light from the emitters that is reflected from the tissue site after attenuation by pulsatile blood flow within the tissue site; and
 - the emitters and detector attached on the attachment assembly bottom side.
4. The physiological sensor according to claim 3 further comprising an interconnect assembly disposed along the attachment assembly bottom side so as to electrically connect the optic assembly and the acoustic assembly with the sensor cable.
5. The physiological sensor according to claim 4 wherein:
 - the interconnect assembly is an elongated flex circuit having a plurality of conductors; and
 - the sensor cable is electrically and mechanically mated with the interconnect assembly so that the sensor cable extends from an attachment assembly end.
6. The physiological sensor according to claim 5 further comprising a sensor cable anchor adhesively attached proximate the tissue site so as to stabilize the sensor cable.
7. The physiological sensor accordingly to claim 1 wherein the acoustic assembly is driven so that the acoustic

13

transducer transmits acoustic vibrations into the tissue site so as to provide an active pulse for optical assembly measurements of pulsed, blood perfused tissue.

8. A physiological sensor comprising:
 an optic means for measuring oxygen saturation;
 an acoustic means for measuring respiration rate; and
 an attachment means for adhering the optic means and the acoustic means to a tissue site at a neck of a patient, the acoustic means coupled to the center of the attachment means
 wherein the attachment means comprises a planar, flexible body having a top side and an adhesive bottom side; the flexible body having a center, a first wing and a second wing;
 the first wing and second wing extending in opposite directions from the center, each wing having a length extending away from the center which is greater than a width thereof;

14

the acoustic means coupled to the center at the bottom side; and the optic means disposed along the bottom side of the first wing and not to the center.

9. The physiological sensor according to claim 8 further comprising an interconnect means for communication between a sensor cable attachable to a monitor and the optic means and the acoustic means.

10. The physiological sensor according to claim 9 wherein the optic means comprises a plurality of emitters and a reflectance-configured detector.

11. The physiological sensor according to claim 10 wherein the acoustic means comprises a piezoelectric membrane.

12. The physiological sensor according to claim 8 further comprising a relatively high voltage drive of the acoustic means for generating an active pulse.

* * * * *

专利名称(译)	光学传感器		
公开(公告)号	US9782110	公开(公告)日	2017-10-10
申请号	US14/928484	申请日	2015-10-30
[标]申请(专利权)人(译)	梅西莫股份有限公司		
申请(专利权)人(译)	Masimo公司		
当前申请(专利权)人(译)	Masimo公司		
[标]发明人	KIANI MASSI JOE E		
发明人	KIANI, MASSI JOE E.		
IPC分类号	A61B5/1455 A61B8/02 A61B8/06 A61B5/00 A61B5/0205 A61B5/08 A61B5/026 A61B5/024		
CPC分类号	A61B5/1455 A61B5/0205 A61B5/0261 A61B5/02427 A61B5/08 A61B5/0816 A61B8/06 A61B5/6814 A61B5/6815 A61B5/6822 A61B5/6823 A61B5/6832 A61B5/14552 A61B5/68335		
优先权	61/350673 2010-06-02 US		
其他公开文献	US20160045118A1		
外部链接	Espacenet USPTO		

摘要(译)

生理传感器具有光学组件，声学组件和附接组件。光学组件具有光学换能器，该光学换能器被激活以便将多个波长的光传输到组织部位并且在通过组织部位内的脉动血流衰减之后检测光。声学组件具有激活的声学换能器，以响应组织部位表面的振动。附接组件将光学组件和声学组件固定到组织部位，例如沿着人的颈部或前额的一侧。传感器电缆从连接组件延伸，以便将光学传感器信号和声换能器信号传输到监视器，以计算生理参数。

