



US 20200047582A1

(19) **United States**

(12) **Patent Application Publication**  
**DEN BRINKER et al.**

(10) **Pub. No.: US 2020/0047582 A1**  
(43) **Pub. Date: Feb. 13, 2020**

(54) **DEVICE, SYSTEM AND METHOD FOR CO2 MONITORING**

**Publication Classification**

(71) Applicant: **KONINKLIJKE PHILIPS N.V.**,  
EINDHOVEN (NL)  
(72) Inventors: **Albertus Cornelis DEN BRINKER**,  
Eindhoven (NL); **Vincent JEANNE**,  
Migne Auxances (FR); **Michel Jozef**  
**Agnes ASSELMAN**, Helmond (NL);  
**Koray KARAKAYA**, Eindhoven (NL);  
**Gerrit Maria KERSTEN**, Veldhoven  
(NL); **Christian Andreas TIEMANN**,  
Eindhoven (NL); **Murtaza BULUT**,  
Eindhoven (NL)

(51) **Int. Cl.**  
*B60H 1/00* (2006.01)  
*A61B 5/00* (2006.01)  
*A61B 5/0205* (2006.01)  
*A61B 5/11* (2006.01)  
(52) **U.S. Cl.**  
CPC ..... *B60H 1/008* (2013.01); *A61B 5/486*  
(2013.01); *A61B 5/0205* (2013.01); *A61B*  
*5/0836* (2013.01); *B60H 1/00742* (2013.01);  
*A61B 2560/0247* (2013.01); *A61B 5/1118*  
(2013.01)

(21) Appl. No.: **16/344,420**  
(22) PCT Filed: **Oct. 27, 2017**  
(86) PCT No.: **PCT/EP2017/077551**  
§ 371 (c)(1),  
(2) Date: **Apr. 24, 2019**

(57) **ABSTRACT**

The present invention relates to a device, system and method for CO2 monitoring. To enable continuous monitoring at low cost and in a simple manner, the device comprises a signal input (10) for obtaining one or more monitoring signals (20) of a monitored area, a breathing monitor (11) for determining one or more breathing parameters (21) of one or more subjects present in the monitored area from the obtained one or more monitoring signals, and a CO2 estimation unit (12) for estimating the CO2 level (22) in the monitored area based on the determined one or more breathing parameters.

(30) **Foreign Application Priority Data**  
Nov. 2, 2016 (EP) ..... 16196883.9

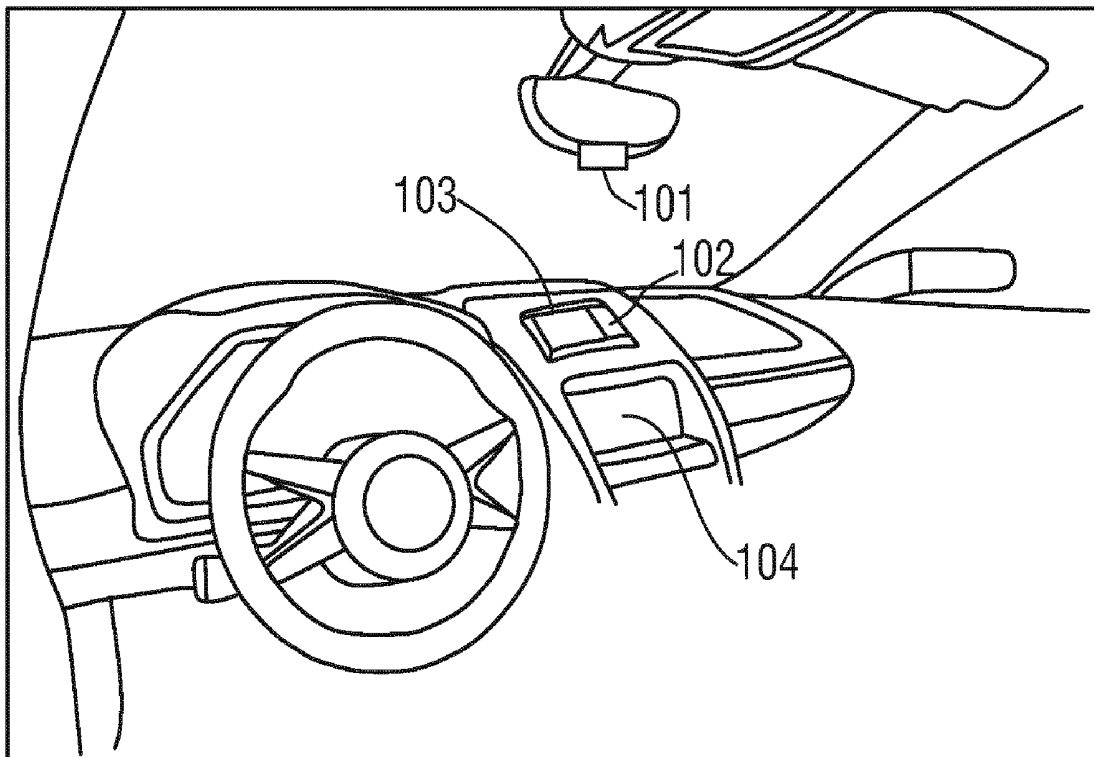

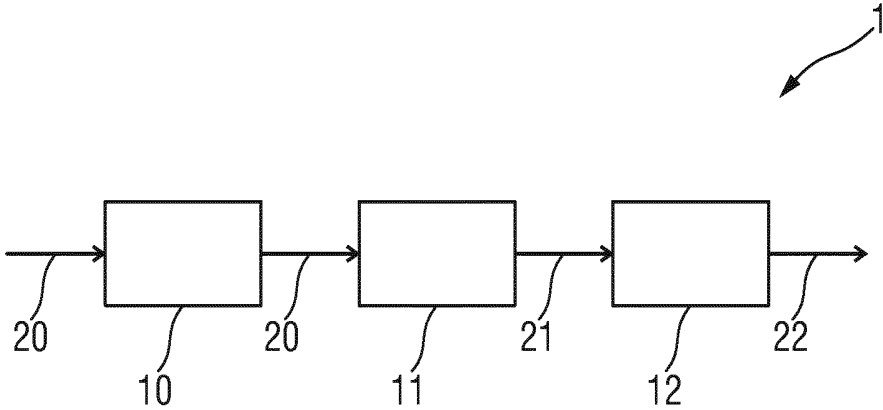

FIG.1

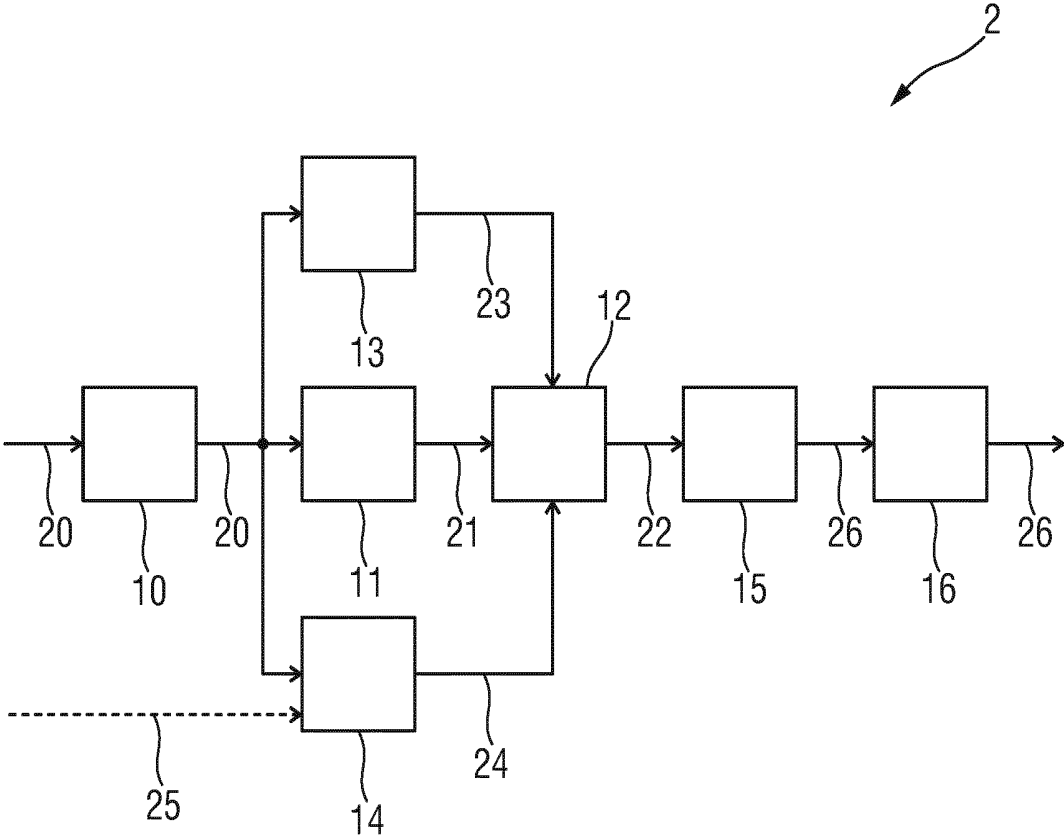

FIG.2

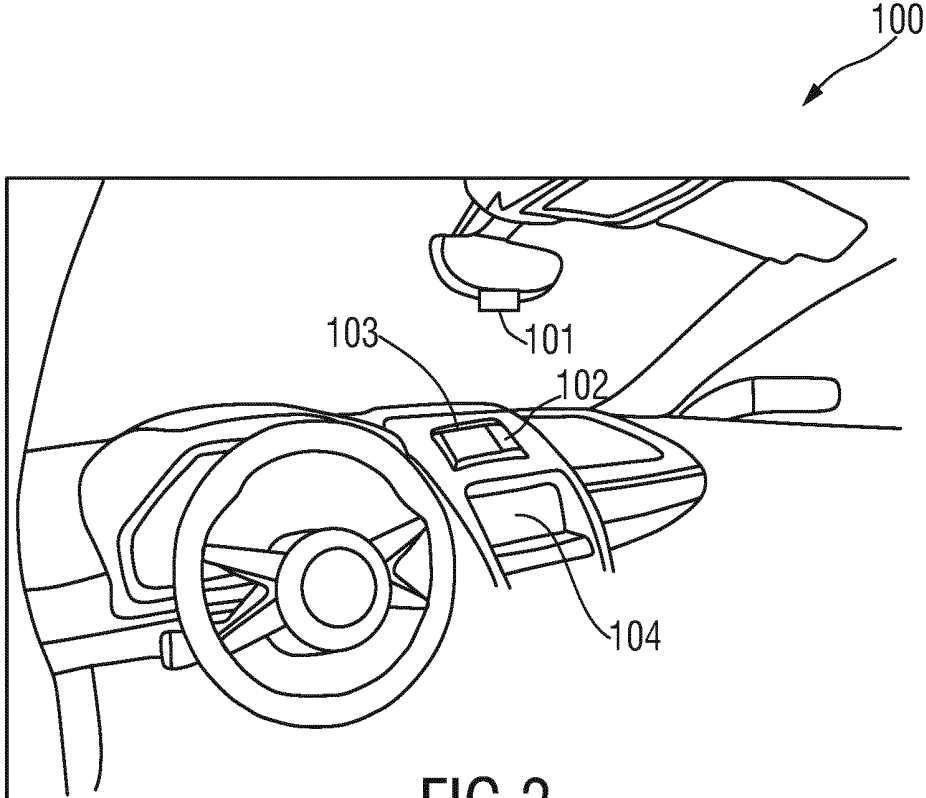

FIG. 3

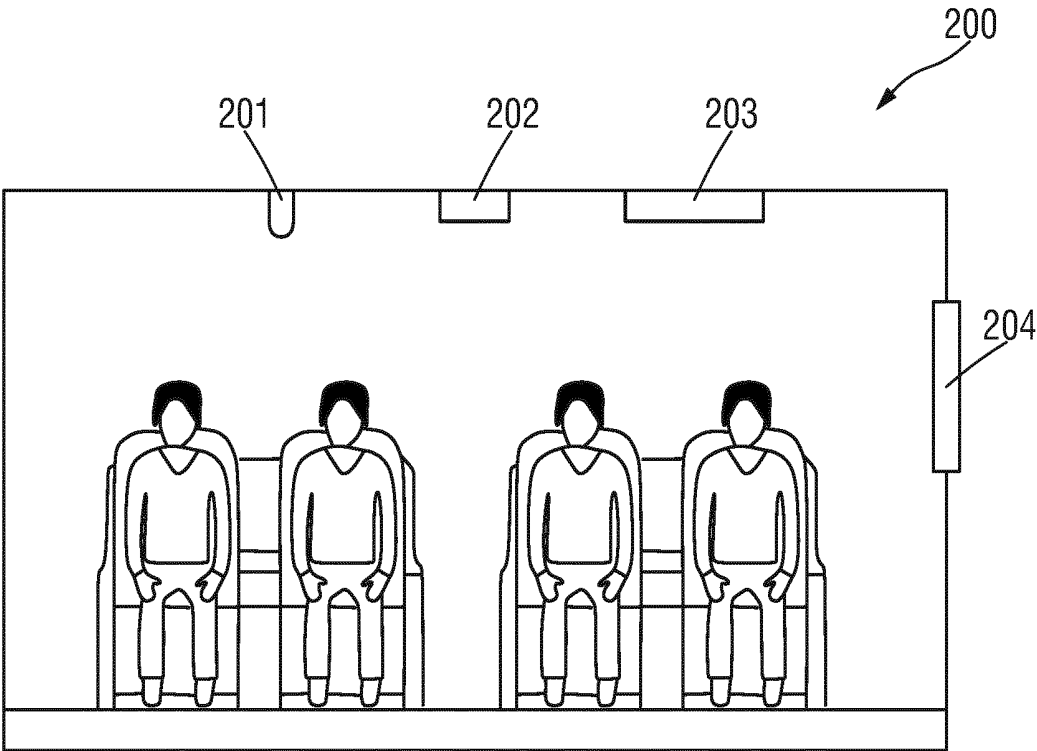

FIG. 4

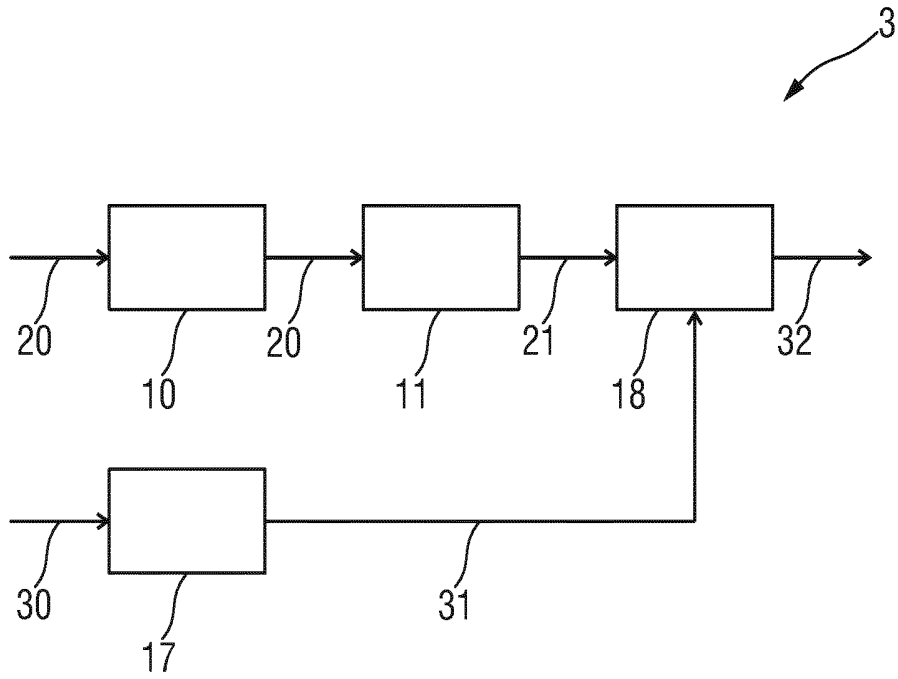

FIG.5

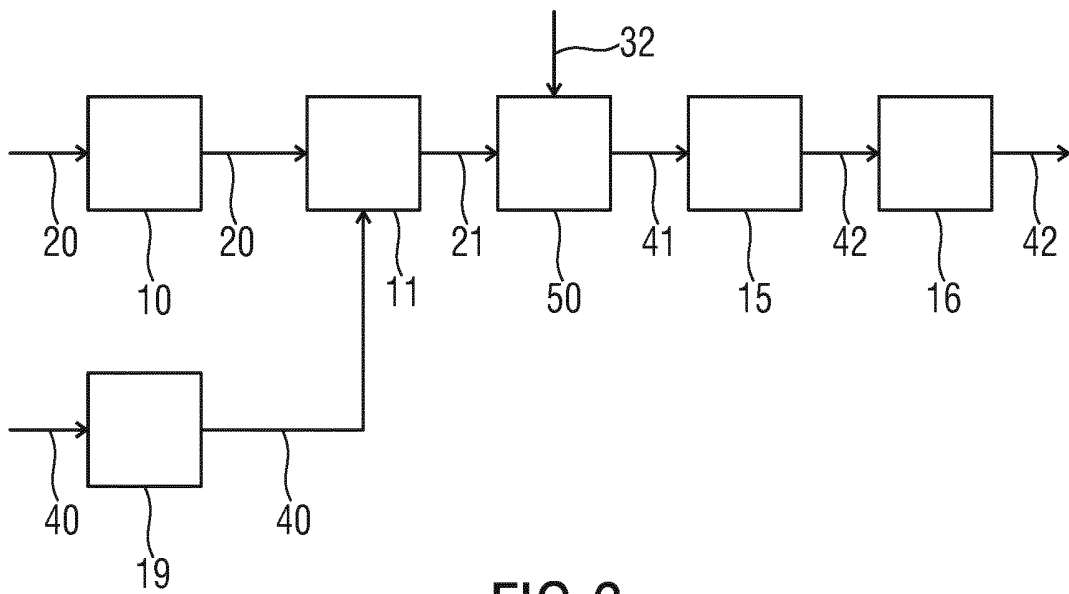

FIG.6

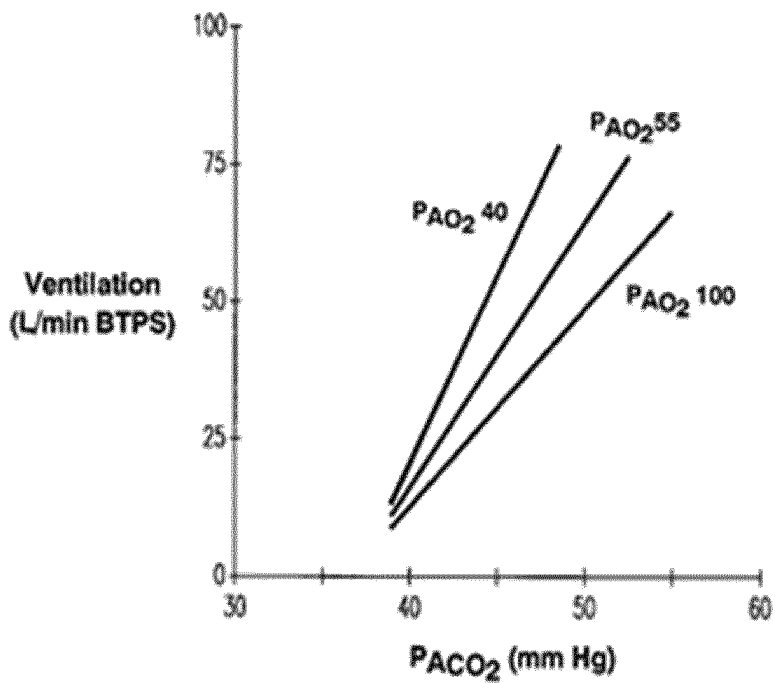

Fig 7a

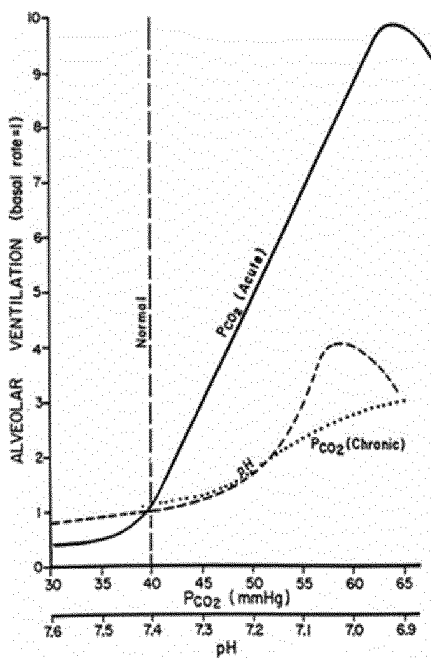

Fig 7b

## DEVICE, SYSTEM AND METHOD FOR CO<sub>2</sub> MONITORING

### FIELD OF THE INVENTION

**[0001]** The present invention relates to a device, system and method for CO<sub>2</sub> monitoring. Further, the present invention relates to a vehicle comprising such a device.

### BACKGROUND OF THE INVENTION

**[0002]** Normal dry air, at standard temperature and pressure (STP) of 101.325 kPa and 0° C., consists of (expressed in volume) 20.95 percent oxygen, 78.08 percent nitrogen, 0.0314 percent carbon dioxide, 0.93 percent argon and trace amounts of 14 other gases. Assuming that the oxygen content of the air is normal, the following figures are typical for confined rooms with very restricted airflow, such as underground mines:

**[0003]** Normal air is 0.03% or 300 ppm CO<sub>2</sub>.

**[0004]** The time-weighted threshold limit value for CO<sub>2</sub> is 0.5% (or 5000 ppm).

**[0005]** Headache and an increased rate of breathing occur at 10000 ppm (1%).

**[0006]** The short-term exposure limit is 30000 ppm (3%), and these amounts result in doubling of normal breathing rate.

**[0007]** Panting and intoxication occur above 50000 ppm (5%).

**[0008]** Unconsciousness occurs above about 100000 ppm (10%).

**[0009]** For daily living situations the following numbers are typical:

**[0010]** If a person stays in a small bedroom and closes all windows/doors, the level will go towards 2000-3000 ppm after a couple of hours.

**[0011]** In commercial transport aircraft cabins, the average CO<sub>2</sub> concentration ranges are 515-4902 ppm, i.e. the higher boundary is very close to the threshold value of 5000 ppm. The recommended limit for continuous exposure is 1000 ppm.

**[0012]** The CO<sub>2</sub> concentration in vehicles very quickly reaches levels of 7000 ppm in recirculation mode. From example, for a vehicle with 3 passengers operating in full recirculation mode, it takes 50 minutes to reach 7000 ppm.

**[0013]** CO<sub>2</sub> is twenty times more soluble in blood than oxygen. So the effect of CO<sub>2</sub> level changes on the physiological parameters are much greater and faster when compared to the changes in O<sub>2</sub> level of the air. Further, the effect of CO<sub>2</sub> percentage increase first affects the breathing in a visible manner, and the heart rate changes only after higher levels are reached.

**[0014]** Assuming that CO<sub>2</sub> levels are normal the following effects of the O<sub>2</sub> changes are observed:

**[0015]** The normal lower working limit for oxygen is 19%.

**[0016]** At 18% oxygen there is a slight increase in breathing effort.

**[0017]** At 16% triggers only a slight increase in heart and breathing rates.

**[0018]** At 14%, emotional upset, impaired judgment and faulty co-ordination occur.

**[0019]** At 12% cardiac damage and vomiting can occur.

**[0020]** At 10%, a person would collapse into consciousness and death.

**[0021]** It has been found that for a person breathing at a rate of 12.5 liters per minute within a 'dead air' space of one cubic meter, an oxygen level of 18 percent will be reached at 58 minutes, whereas carbon dioxide levels will reach the threshold limit value of 0.5 percent at only 12 minutes, and the upper working limit of 1.25 percent at 30 minutes. This indicates that monitoring and eliminating the build-up of CO<sub>2</sub> is much more critical than monitoring and preventing the drop in oxygen.

**[0022]** Decreased blood oxygen, increased CO<sub>2</sub>, and decreased pH level may result in the following physiological changes: A decrease of parasympathetic stimulation of heart, which increases the heart rate (HR), and an increase of sympathetic stimulation of the heart, which increases HR and stroke volume, which increases vasoconstriction.

**[0023]** The CO<sub>2</sub> level in air is not the only factor affecting the respiration rate and tidal volume (i.e. the depth of inhalation and exhalation). The response to a stressful experience leads to a changing concentration of catecholamines in the blood. An increasing concentration of epinephrine or norepinephrine leads to a respiration rate increasing rapidly (within a few minutes). Catecholamines have a half-life of a few minutes when circulating in the blood, as a result the respiration level will drop back to its baseline level within the order of minutes. In these cases, the heart rate will also change.

**[0024]** It should be noted that for certain patient groups (e.g. COPD) the sensitivity to CO<sub>2</sub> level changes can be greater.

**[0025]** The obvious method to monitor the CO<sub>2</sub> concentration level is using CO<sub>2</sub> sensors, in which the most common type is non-dispersive infrared (NDIR) sensors. There are several limitations of this approach however: first, such sensors may be costly (although in recent years the price is dropping significantly), and second they are useful only for one function, namely for measuring the CO<sub>2</sub> level.

### SUMMARY OF THE INVENTION

**[0026]** It is an object of the present invention to provide a device, system and method for CO<sub>2</sub> monitoring and particularly detecting an increase in CO<sub>2</sub> volume at lower costs, wherein the device and system may preferably be usable for more than one purpose. In a first aspect of the present invention a device for CO<sub>2</sub> monitoring is presented comprising:

**[0027]** a signal input configured to receive one or more monitoring signals of a monitored area, said monitoring signals being comprised in image data of the monitored area,

**[0028]** a breathing monitor configured to determine one or more breathing parameters of one or more subjects present in the monitored area from the obtained one or more monitoring signals, and

**[0029]** a CO<sub>2</sub> estimation unit configured to estimate the CO<sub>2</sub> level in the monitored area from a change in the determined one or more breathing parameters.

**[0030]** In a further aspect of the present invention a system for CO<sub>2</sub> monitoring is presented comprising:

**[0031]** a monitoring unit for acquiring one or more monitoring signals (20) of a monitored area, and

**[0032]** a device as disclosed herein for CO<sub>2</sub> monitoring based on the acquired one or more monitoring signals.

**[0033]** In a further aspect of the present invention a vehicle is presented comprising a device as disclosed herein for outputting one or more output signals for controlling a device of the vehicle and/or for recommending one or more actions to be taken.

**[0034]** In yet further aspects of the present invention, there are provided a corresponding method, a computer program which comprises program code means for causing a computer to perform the steps of the method disclosed herein when said computer program is carried out on a computer as well as a non-transitory computer-readable recording medium that stores therein a computer program product, which, when executed by a processor, causes the method disclosed herein to be performed.

**[0035]** Preferred embodiments of the invention are defined in the dependent claims. It shall be understood that the claimed method, system, vehicle, computer program and medium have similar and/or identical preferred embodiments as the claimed device, in particular as defined in the dependent claims and as disclosed herein.

**[0036]** The present invention is based on the idea to monitor the physiological state, in particular the respiratory function, of one or more monitored subjects (i.e. persons), preferably with unobtrusive monitoring means such as a camera. Based on the monitored user parameters, the CO<sub>2</sub> concentration changes can be estimated and appropriate actions may be taken or recommended to bring down the CO<sub>2</sub> concentration to a normal level.

**[0037]** The proposed idea is particularly useful for monitoring the CO<sub>2</sub> level in confined spaces. Such places include professional working environments such as mines and labs, and everyday places where air circulation can be limited or not, such as inside vehicles, and especially vehicles with multiple people.

**[0038]** According to an embodiment, the CO<sub>2</sub> estimation unit is configured to estimate an increase in CO<sub>2</sub> level when it observes positive change in at least one of breathing rate and breathing volume.

**[0039]** According to an embodiment, the breathing monitor is further configured to establish baseline breathing parameters by obtaining an average breathing rate over an initial period and wherein the CO<sub>2</sub> estimation unit estimates the CO<sub>2</sub> by comparison of the one or more breathing parameters to said baseline.

**[0040]** According to a preferred embodiment the device may further comprise an output signal generation unit for generating, in dependence on the estimated CO<sub>2</sub> level, one or more output signals for controlling an external device and/or for recommending one or more actions to be taken and/or for information, and a signal output for outputting the one or more output signals. For instance, in a vehicle or room the air condition, the state of windows or doors, etc. may be controlled automatically, or recommendations may be issued for guiding the one or more subjects what to do to improve the CO<sub>2</sub> level.

**[0041]** In another embodiment said output generation unit is configured to generate, as one or more output signals, one or more of a control signal for controlling or a recommendation to change the setting of a ventilation system, an air purifier, an air condition, one or more openings of a room, or a recommendation to change the location, or change the breathing, or minimize the physical activity. Generally, any external device may be controlled or any recommendation may be issued that may help to improve the CO<sub>2</sub> level.

Hereby, the designer or applicant of the system may implement certain control rules or recommendations based on the circumstances and the respective system elements that are available.

**[0042]** The signal input is preferably configured to obtain image data of the monitored area as monitoring signals and the breathing monitor is configured to determine said one or more breathing parameters from the obtained image data. For instance, motion of the belly or chest area may be detected in the image data (e.g. a time sequence of images or video data) to detect the respiration rate and/or respiration volume. Alternatively, the generally known photoplethysmography (PPG) technique may be used for this purpose. Methods for evaluating such motion or for using PPG for this purpose are generally known.

**[0043]** Various breathing parameters may hereby be used. The breathing monitor may thus be configured to determine, as breathing parameters, one or more of breathing rate, breathing depth, inspiratory time, expiratory time, inspiration to expiration time ratio, total breath time, fractional inspiration time, tidal volume, variability in one or more breathing parameters and changes of one or more breathing parameters over time.

**[0044]** In another embodiment said breathing monitor is configured to separately determine one or more breathing parameters for two or more subjects present in the monitored area and to identify changes of one or more breathing parameters for the two or more subjects separately. The CO<sub>2</sub> estimation unit is then configured to estimate the absolute CO<sub>2</sub> level based on the identified changes of one or more breathing parameters for the two or more subjects. Hence, by use of the present invention the breathing parameters for multiple persons can be determined separately, which can be used together for determining the CO<sub>2</sub> level at an increased accuracy.

**[0045]** The breathing monitor may also be configured to identify changes of the one or more breathing parameters for the two or more subjects with respect to a baseline for the respective breathing parameter, in particular with respect to a common baseline for two or more subjects or with respect to individual baselines for one or more subjects. This further increases the CO<sub>2</sub> level estimation.

**[0046]** In another embodiment the breathing monitor may be configured to identify changes of the breathing rate per subject and the CO<sub>2</sub> estimation unit may be configured to determine, if the breathing rate and/or its change rate exceed a respective threshold for two or more subjects, that the CO<sub>2</sub> level has exceeded a CO<sub>2</sub> level threshold. This provides a simple but effective way of estimating the CO<sub>2</sub> level.

**[0047]** The CO<sub>2</sub> estimation unit may be configured to estimate the absolute CO<sub>2</sub> level and/or changes of the CO<sub>2</sub> level over time. This may provide further useful information for the user or the system, e.g. to decide if and which measures to take.

**[0048]** Preferably, the signal input is configured to obtain supplementary data including one or more of air quality data, environmental data, subject behavior data, and sensor data, wherein said breathing monitor is configured to identify changes of the one or more breathing parameters for an individual subject, in particular with respect to a baseline, from the obtained one or more monitoring signals and the obtained supplementary data. This leads to an increased accuracy of the CO<sub>2</sub> level estimation.

[0049] The device may further comprise a heart rate monitor for determining heart rate of the one or more subjects, wherein the CO<sub>2</sub> estimation unit is configured to estimate the CO<sub>2</sub> level in the monitored area based on the determined one or more breathing parameters and the determined heart rate and/or changes of heart rate over time. This further increases the accuracy. Optical heart rate monitors are also able to estimate breathing rate from PPG signals. Hence, an optical heart rate monitor could be used to replace or supplement the above-mentioned breathing detection. For instance, a wrist-worn device, like a fitness monitor or health watch, may be used to detect heart rate and/or breathing rate.

[0050] The device may further comprise a motion detector for detecting physical motion of a subject, wherein said CO<sub>2</sub> estimation unit is configured to ignore breathing parameters of a subject determined during a phase of physical motion of said subject above a motion threshold or take said physical motion into account in the estimation of the CO<sub>2</sub> level.

#### BRIEF DESCRIPTION OF THE DRAWINGS

[0051] These and other aspects of the invention will be apparent from and elucidated with reference to the embodiment(s) described hereinafter. In the following drawings

[0052] FIG. 1 shows a schematic diagram of a first embodiment of a device according to the present invention,

[0053] FIG. 2 shows a schematic diagram of a second embodiment of a device according to the present invention,

[0054] FIG. 3 shows a cockpit of a vehicle in accordance with an aspect of the present invention,

[0055] FIG. 4 shows a schematic diagram of an embodiment of a system in accordance with another aspect of the present invention,

[0056] FIG. 5 shows a schematic diagram of a third embodiment of a device according to the present invention, and

[0057] FIG. 6 shows a schematic diagram of a fourth embodiment of a device according to the present invention.

#### DETAILED DESCRIPTION OF THE INVENTION

[0058] FIG. 1 shows a schematic diagram of a first embodiment of a device 1 according to the present invention. The device 1 comprises a signal input 10 for obtaining one or more monitoring signals 20 of a monitored area, a breathing monitor 11 for determining one or more breathing parameters 21 of one or more subjects present in the monitored area from the obtained one or more monitoring signals, and a CO<sub>2</sub> estimation unit 12 for estimating the CO<sub>2</sub> level 22 in the monitored area based on the determined one or more breathing parameters.

[0059] The device 1 may generally be implemented in hard- and/or software, e.g. as a processor, computer or application program (“app”) running on a user device, such as a smartphone, that is programmed accordingly.

[0060] One main application of the present invention may be in vehicles, such as cars and buses. A car can be considered a confined environment, provided that the ventilation system of the car controls the fresh air intake (from outside). Nowadays cars are equipped with ventilation systems that can monitor the outside air pollution and based on its level can decide to prevent access to outside air, to allow the outside air to enter in. Obviously, the driver can also change these ventilation settings. Other possible applica-

tions might be waiting rooms or hospital rooms. CO<sub>2</sub> build-up is most common in enclosed spaces, though these do not need to be completely enclosed because CO<sub>2</sub> is slightly denser than air and tends to sit in pockets in still air. Therefore, the more common use areas might be in enclosed or partially enclosed spaces but use may be possible in more open areas, though air movements there may often make it less useful.

[0061] The monitoring unit for acquiring the monitoring signal 20 may be a camera, such as a vital signs camera used in vital signs monitoring using PPG techniques, targeting the respiration monitoring in particular. In an embodiment the camera images are processed and a respiration signal is created. Using camera image further enables discrimination between users. Multiple users can be monitored with a single camera. In more detail, there are various techniques for monitoring and extracting the respiration or breathing signal. One possibility can be by detecting movement in the chest and/or abdomen using movement detection processing on the images. Clothing can cause problems for this method. Another technique is to form 1D projections of a selected region and correlating 1D projections from images obtained at different times. Another possibility is to use colour changes in the skin to extract a heart rate signal and detect changes in this which are caused by breathing. This technique requires exposed skin areas to be in the monitored area though this can be ensured by choosing the position of the camera.

[0062] From the respiration signal, respiration markers can be extracted. For instance, respiratory frequency, inspiratory time, expiratory time, inspiration to expiration time ratio, total breath time, tidal volume, fractional inspiration time, breath depth, variability of in the respiration parameters (frequency, intensity, timing parameters) are variables that can be derived from the respiratory signal. Some of these have clinical relevance especially for populations at risk such as COPD patients.

[0063] Alternatively, other monitoring units different from a vital signs camera, which are capable of monitoring one or more breathing parameters, can also be used for the same purpose.

[0064] In an embodiment, changes in the breathing rate and depth are observed. When many people are travelling together the risk of increased CO<sub>2</sub> level is greater, which case will be described in the following. First, a baseline breathing rate (and depth) of each person may be determined. Next, each passenger is continuously monitored with regard to the breathing rate changes. As explained above, air CO<sub>2</sub> volume increase causes breathing rate to increase. This is a reaction of the body, and individuals do not have control over it. Benefiting from this clear physiological reaction, the breathing rate changes for each person are detected, and when it is observed that the rate has increased and is continuing to increase for each person, an alert of high CO<sub>2</sub> volume in air is activated. A similar reaction is expected for each person in the car. Hereby, other effects influencing the breathing rate besides CO<sub>2</sub> can be cancelled out.

[0065] FIGS. 7a and 7b (Caruana et al, “The Control of Breathing in Clinical Practice, CHEST 2000; 117; 20-225) show how the concentration of CO<sub>2</sub> is related to the breathing rate. FIG. 7a shows that the ventilation rate (measure in volume of air moved) increases proportionally to increased CO<sub>2</sub> concentration. From FIG. 7b, it can be seen that the increase in ventilation starts to occur very soon after there is

an increase of CO<sub>2</sub> concentrations from normal levels and that the relationship is very close to linear until higher CO<sub>2</sub> levels are reached. Also it can be seen that a increase in CO<sub>2</sub> concentration from 40 to 60 mmHg causes a eight-fold increase in ventilation i.e. the constant of proportionality is 0.4. The ventilation or breathing rate is tidal volume multiplied by the frequency of breathing, the change of CO<sub>2</sub> concentration can be deduced from the change in these breathing parameters. Breathing depth is directly related to tidal volume and the breathing volume is, for a given person, related to the breathing amplitude. The breathing amplitude can be derived from the breathing signal.

[0066] FIG. 2 shows a schematic diagram of a second embodiment of a device 2 according to the present invention. In this embodiment one or more further elements may be provided.

[0067] In one implementation the device 2 may further comprise a heart rate monitor 13 for determining heart rate 23 of the one or more subjects, wherein the CO<sub>2</sub> estimation unit 11 is configured to estimate the CO<sub>2</sub> level in the monitored area based on the determined one or more breathing parameters and the determined heart rate and/or changes of heart rate over time. The heart rate monitor 13 may be configured to detect the heart rate from the monitoring signals 20, e.g. by use of the PPG technique. Alternatively, other means for determining the heart rate may be provided, e.g. by use of a dedicated heart rate sensor, such as a pulse oximeter.

[0068] In another implementation the device 2 may further comprise a motion detector 14 for detecting physical motion 24 of a subject, wherein said CO<sub>2</sub> estimation unit 12 is configured to ignore breathing parameters of a subject determined during a phase of physical motion of said subject above a motion threshold or take said physical motion into account in the estimation of the CO<sub>2</sub> level. The motion detector 14 may be configured to detect the motion from the monitoring signals 20, e.g. by use of the PPG technique. Alternatively, other means for determining the motion may be provided, e.g. by use of a dedicated motion sensor, such as an accelerometer.

[0069] In another implementation the device 2 may further comprise an output signal generation unit 15 for generating, in dependence on the estimated CO<sub>2</sub> level, one or more output signals 26 for controlling an external device and/or for recommending one or more actions to be taken and/or for information, and a signal output 16 for outputting the one or more output signals 26. The signal output 16 may e.g. comprise a display and/or a loudspeaker for issuing a recommendation and/or an interface for issuing a control signal to an external device.

[0070] Thus, upon activation of an alert, the desire is to take actions to bring the air CO<sub>2</sub> volume back to normal levels. This can be done in multiple ways:

[0071] The setting of the vehicle ventilation system can change, so that more clear air is allowed to enter from outside, or the ventilation mode can be adjusted.

[0072] In case the outside air severely polluted, the driver can be instructed to take a different route, where the air is cleaner. In case of autonomous vehicles, the vehicle can adapt its route based on the observed changes in the respiration rate of the passengers.

[0073] If additional (external) devices such as air purifiers that can get rid of excess CO<sub>2</sub> are available, they can be activated.

[0074] Additionally, oxygen, oxygen enriched air, or clean air can be pumped in the environment.

[0075] The passengers can be instructed to minimize the physical activity and/or to breathe slowly.

[0076] FIG. 3 shows a cockpit of a vehicle 100 in accordance with an aspect of the present invention. The vehicle, in this exemplary embodiment a car, represents an embodiment of the disclosed system and comprises a monitoring unit 101, such as a camera, a device 102 as disclosed herein for outputting one or more output signals for controlling a device 103, 104 of the vehicle and/or for recommending one or more actions to be taken. The device 103 may e.g. be the air condition of the vehicle 100 and the device 104 may e.g. be the monitor of the navigation system of the vehicle. Thus, the air condition 103 may be controlled automatically or a message may be issued on the monitor what the passengers should do (e.g. open the window).

[0077] FIG. 4 shows a schematic diagram of another embodiment of a system 200 in accordance with another aspect of the present invention. The system 200 is installed in this exemplary embodiment in a room, e.g. in a waiting room of an office building or a hospital. The system 200 comprises a monitoring unit 201, e.g. a camera, a device 202 as disclosed herein and two external devices 203, 204 that may be automatically controlled, such as the room's air condition 203 or a window 204.

[0078] A benefit of monitoring multiple persons is that the results can be averaged between those persons thereby reducing the effect of spurious results arising from changes in the breathing parameters of one person being caused by other factors than CO<sub>2</sub> levels.

[0079] Especially for people suffering from breathing problems (COPD, asthma), or people having problems with lungs and kidneys (the organs that compensate for pH imbalances) the proposed invention is of particular relevance. The ventilation setting in the car is designed having healthy people in mind. Similarly the settings of an air purifier are generally designed with healthy people in mind. This means that these settings may not be optimal for non-healthy people. Using the proposed approach, which enables real-time monitoring, the user health (in this case respiration) information can be fed-back to these devices (in a closed loop feedback system) and the operation of these devices can be adjusted accordingly.

[0080] Due to a stressful experience, the respiration rate can increase and decrease, however the time frame in which this takes place is in the order of minutes, after which the respiration rate will drop back to its baseline rate. Hence, by observing longer-term trends, the effect on respiration rate due to CO<sub>2</sub> can still be distinguished. Thus, in one embodiment the breathing monitor (11) is configured to identify changes of the one or more breathing parameters for two or more subjects with respect to a baseline for the respective breathing parameter, in particular with respect to a common baseline for two or more subjects or with respect to individual baselines for one or more subjects.

[0081] FIG. 5 shows a schematic diagram of a third embodiment of a device 3 according to the present invention. The device 3 may be used to obtain a baseline or baseline model 32 for the subject's breathing rate changes due to CO<sub>2</sub> level changes. The baseline or baseline model 32 can be determined at predetermined or irregular intervals, e.g. every year or every month and may then be used by the device to determine the actual CO<sub>2</sub> level. Also, the baseline

may be may be obtained by performing measurements for an initial period, for example ten to fifteen minutes and taking an average of the measurements as the baseline. The average could be an arithmetic mean, a median or a modal value. It is better that the initial period occur close to when the people enter the monitored space after it has been un- or lightly occupied for a while since the CO<sub>2</sub> levels should, in theory, be close to the natural background levels.

**[0082]** In addition to the elements of the device 1 shown in FIG. 1, the device 3 further comprises a signal input 17 for obtaining environmental data, such a known CO<sub>2</sub> level conditions in a controlled environment, known CO<sub>2</sub> levels and known air quality data. From monitoring the breathing rate using a camera under such conditions monitoring data are obtained at the signal input 10, which are then used by the breathing monitor to determine one or more breathing parameters 21 of the subject and to estimate the baseline or baseline model 32 by the CO<sub>2</sub> estimation unit 18. The signal input may also be coupled to a CO<sub>2</sub> sensor from which an absolute measurement may be made. Such a sensor could be placed in the space in question or even in the air purifier (where present) or other air conditioning systems.

**[0083]** During actual measurement the baseline or baseline model 32 will be used in the estimation of the CO<sub>2</sub> level. In particular, the CO<sub>2</sub> level may be estimated and deviations from the baseline or baseline model 32 may be determined.

**[0084]** In another embodiment the device and method can be used to continuously monitor the health state of the subject.

**[0085]** FIG. 6 shows a schematic diagram of a fourth embodiment of a device 4 according to the present invention. In this embodiment the signal input 19 is configured to obtain supplementary data 40 including one or more of air quality data, environmental data, subject behavior data, and sensor data. The breathing monitor 11 identifies changes of the one or more breathing parameters for an individual subject, in particular with respect to a baseline 32, from the obtained one or more monitoring signals 20 and the obtained supplementary data 40.

**[0086]** In another embodiment the breathing rate and heart rate change interaction are exploited. CO<sub>2</sub> level changes are generally very well correlated with changes in the respiration parameters, and less with the changes in heart rate. Using this fact, observing an increase in breathing rate with no changes in heart rate, or observing fast changes in breathing rate and slow changes in heart rate can be taken as a sign of increased CO<sub>2</sub> level and appropriate actions can be taken to normalize it.

**[0087]** In another embodiment health state monitoring can be performed. Long-term respiration related health condition monitoring, by collecting data over a time frame, and correlating the respiration features to the air quality level present in the car can be used for this purpose. That is, monitoring and changing the air quality through the air purified, and through air purified settings, respiration features, and optionally the car features in a closed loop may be performed. These may be used to generate an overview of health state of the user, and in particular of the diseases or symptom of the user. For example, in one embodiment it may be checked how the air pollution influences the respiration parameters to better evaluate and/or understand the health state of the person.

**[0088]** In another embodiment the user may be coached as mentioned above. Recommendations to the user or to device manufacturers may e.g. be generated. For example, a user can be advised to take a route with a cleaner air, the user/air purifier manufacturer can be advised to replace filter, or to use a particular filter better matching users common routes and destinations, user can be advised to breath in a particular way depending on the air quality at the particular moment (for example, take shallow breaths when air quality is bad, and deeper breaths when better). Further, recommendations can be made to alleviate a particular condition such as asthma, coughing, and dizziness.

**[0089]** Physical exercise can influence the respiration rate. Thus, using the camera, physical exercise could be detected based on motion of the subject's body, and the time interval excluded from CO<sub>2</sub> measurement. Physical exercise is known to have a combined effect on respiration rate and heart rate. So in case the heart rate is also measured, the physical exercise could be detected and estimated based on the combined increase in heart rate, and the effect on the respiration rate could be compensated for.

**[0090]** While the invention has been illustrated and described in detail in the drawings and foregoing description, such illustration and description are to be considered illustrative or exemplary and not restrictive; the invention is not limited to the disclosed embodiments. Other variations to the disclosed embodiments can be understood and effected by those skilled in the art in practicing the claimed invention, from a study of the drawings, the disclosure, and the appended claims.

**[0091]** In the claims, the word "comprising" does not exclude other elements or steps, and the indefinite article "a" or "an" does not exclude a plurality. A single element or other unit may fulfill the functions of several items recited in the claims. The mere fact that certain measures are recited in mutually different dependent claims does not indicate that a combination of these measures cannot be used to advantage.

**[0092]** A computer program may be stored/distributed on a suitable non-transitory medium, such as an optical storage medium or a solid-state medium supplied together with or as part of other hardware, but may also be distributed in other forms, such as via the Internet or other wired or wireless telecommunication systems.

**[0093]** Any reference signs in the claims should not be construed as limiting the scope.

1. A device for CO<sub>2</sub> monitoring comprising:
  - a signal input configured to receive one or more monitoring signals of a monitored area, said monitoring signals being comprised in image data of the monitored area;
  - a breathing monitor configured to determine one or more breathing parameters of one or more subjects present in the monitored area from the one or more monitoring signals, and
  - a CO<sub>2</sub> estimation unit configured to estimate a change in the CO<sub>2</sub> level in the monitored area from a change in the determined one or more breathing parameters.
2. The device according to claim 1 wherein the CO<sub>2</sub> estimation unit is configured to estimate an increase in CO<sub>2</sub> level when it observes positive change in at least one of breathing rate and breathing volume.
3. The device according to claim 1 wherein the breathing monitor is further configured to establish baseline breathing

parameters by obtaining an average breathing rate over an initial period and wherein the CO<sub>2</sub> estimation unit estimates the CO<sub>2</sub> by comparison of the one or more breathing parameters to said baseline.

4. The device according to claim 1, wherein said breathing monitor is configured to separately determine one or more breathing parameters for two or more subjects present in the monitored area and to identify changes of one or more breathing parameters for the two or more subjects separately and

wherein said CO<sub>2</sub> estimation unit is configured to estimate the absolute CO<sub>2</sub> level based on the identified changes of one or more breathing parameters for the two or more subjects.

5. The device according to claim 1 further comprising an output signal generation unit for generating, in dependence on the estimated CO<sub>2</sub> level, one or more output signals for controlling an external device and/or for recommending one or more actions to be taken and/or for information, and

a signal output for outputting the one or more output signals.

6. The device according to claim 5, wherein said output generation unit is configured to generate, as one or more output signals, one or more of a control signal for controlling or a recommendation to change the setting of a ventilation system, an air purifier, an air condition, one or more openings of a room, or a recommendation to change the location, or change the breathing, or minimize the physical activity.

7. The device according to claim 2, wherein said breathing monitor is further configured to determine, as breathing parameters, one or more inspiratory time, expiratory time, inspiration to expiration time ratio, total breath time, fractional inspiration time, variability in one or more breathing parameters and changes of one or more breathing parameters over time.

8. The device according to claim 2, wherein said breathing monitor is configured to identify changes of the breathing rate per subject and said CO<sub>2</sub> estimation unit is configured to determine, if the breathing rate and/or its change rate exceed a respective threshold for two or more subjects, that the CO<sub>2</sub> level has exceeded a CO<sub>2</sub> level threshold.

9. The device according to claim 1, wherein said CO<sub>2</sub> estimation unit is configured to estimate the absolute CO<sub>2</sub> level and/or changes of the CO<sub>2</sub> level over time.

10. The device according to claim 1, wherein said signal input is configured to obtain supplementary data including

one or more of air quality data, environmental data, subject behavior data, and sensor data,

wherein said breathing monitor is configured to identify changes of the one or more breathing parameters for an individual subject, in particular with respect to a baseline, from the one or more monitoring signals and the obtained supplementary data.

11. The device according to claim 1, further comprising one or more of

a heart rate monitor for determining heart rate of the one or more subjects, wherein the CO<sub>2</sub> estimation unit is configured to estimate the CO<sub>2</sub> level in the monitored area based on the determined one or more breathing parameters and the determined heart rate and/or changes of heart rate over time, and

a motion detector for detecting physical motion of a subject,

wherein said CO<sub>2</sub> estimation unit is configured to ignore breathing parameters of a subject determined during a phase of physical motion of said subject above a motion threshold or take said physical motion into account in the estimation of the CO<sub>2</sub> level.

12. A system for CO<sub>2</sub> monitoring comprising:

a monitoring unit for acquiring one or more monitoring signals of a monitored area, and

a device of claim 1.

13. A method according to CO<sub>2</sub> monitoring comprising: obtaining one or more monitoring signals of a monitored area, said monitoring signals being comprised in image data of the monitored area;

determining one or more breathing parameters of one or more subjects present in the monitored area from the obtained one or more monitoring signals, and

estimating a change in the CO<sub>2</sub> level in the monitored area from a change in the determined one or more breathing parameters.

14. Computer program comprising program code means for causing a computer to carry out the steps of the method of claim 13 when said computer program is carried out on the computer.

15. Vehicle comprising a device according to claim 1 for outputting one or more output signals for controlling a device of the vehicle and/or for recommending one or more actions to be taken.

\* \* \* \* \*

专利名称(译)	二氧化碳监测的装置，系统和方法		
公开(公告)号	<a href="#">US20200047582A1</a>	公开(公告)日	2020-02-13
申请号	US16/344420	申请日	2017-10-27
[标]申请(专利权)人(译)	皇家飞利浦电子股份有限公司		
申请(专利权)人(译)	皇家飞利浦N.V.		
当前申请(专利权)人(译)	皇家飞利浦N.V.		
[标]发明人	DEN BRINKER ALBERTUS CORNELIS JEANNE VINCENT ASSELMAN MICHEL JOZEF AGNES KARAKAYA KORAY KERSTEN GERRIT MARIA TIEMANN CHRISTIAN ANDREAS BULUT MURTAZA		
发明人	DEN BRINKER, ALBERTUS CORNELIS JEANNE, VINCENT ASSELMAN, MICHEL JOZEF AGNES KARAKAYA, KORAY KERSTEN, GERRIT MARIA TIEMANN, CHRISTIAN ANDREAS BULUT, MURTAZA		
IPC分类号	B60H1/00 A61B5/00 A61B5/0205 A61B5/11		
CPC分类号	A61B5/1118 A61B5/0836 A61B2560/0247 B60H1/008 A61B5/0816 A61B5/0205 B60H1/00742 A61B5/486 A61B5/091 A61B5/02405 A61B5/0077 A61B5/02416 A61B5/681 A61B2503/22 F24F2110/70		
优先权	2016196883 2016-11-02 EP		
外部链接	<a href="#">Espacenet</a> <a href="#">USPTO</a>		

摘要(译)

本发明涉及用于CO<sub>2</sub>监测的设备，系统和方法。为了以低成本和简单方式进行连续监视，该设备包括用于获得监视区域的一个或多个监视信号20的信号输入10，用于监视区域的呼吸监视程序(11)。根据所获得的一个或多个监视信号来确定监视区域中存在的一个或多个对象的一个或多个呼吸参数(21)，以及用于估计CO<sub>2</sub>水平(22)的CO<sub>2</sub>估计单元12。根据所确定的一个或多个呼吸参数在被监测区域内呼吸。

