



(19) **United States**

(12) **Patent Application Publication**
Boesen

(10) **Pub. No.: US 2018/0008194 A1**
(43) **Pub. Date: Jan. 11, 2018**

(54) **DETECTION OF METABOLIC DISORDERS USING WIRELESS EARPIECES**

(52) **U.S. Cl.**
CPC *A61B 5/6803* (2013.01); *A61B 5/0095* (2013.01); *A61B 5/0015* (2013.01); *A61F 5/0013* (2013.01)

(71) Applicant: **BRAGI GmbH**, Munchen (DE)

(72) Inventor: **Peter Vincent Boesen**, Munchen (DE)

(73) Assignee: **BRAGI GmbH**, Munchen (DE)

(57) **ABSTRACT**

(21) Appl. No.: **15/638,011**

(22) Filed: **Jun. 29, 2017**

Related U.S. Application Data

(60) Provisional application No. 62/358,764, filed on Jul. 6, 2016.

Publication Classification

(51) **Int. Cl.**
A61B 5/00 (2006.01)
A61F 5/00 (2006.01)

A method for determining a status of a user utilizing wireless earpieces includes performing sensor measurements of a user utilizing at least optical sensors of the wireless earpieces, wherein the optical sensors detect metabolic abnormalities of the user, analyzing the sensor measurements, determining the status of the user utilizing at least sensor measurements from the optical sensors of the wireless earpieces, and communicating an alert to the user in response to there being a change in the status of the user. A wireless earpiece or set of wireless earpieces with optical sensors for detecting metabolic abnormalities are also provided.

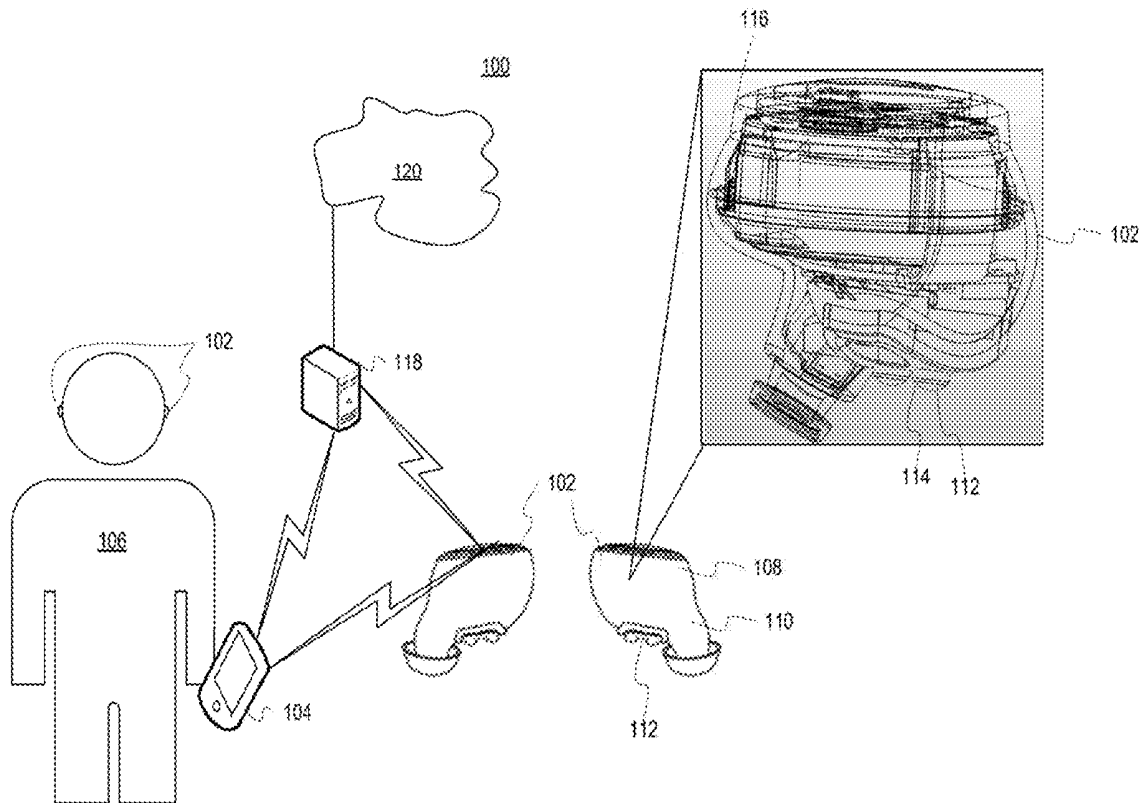

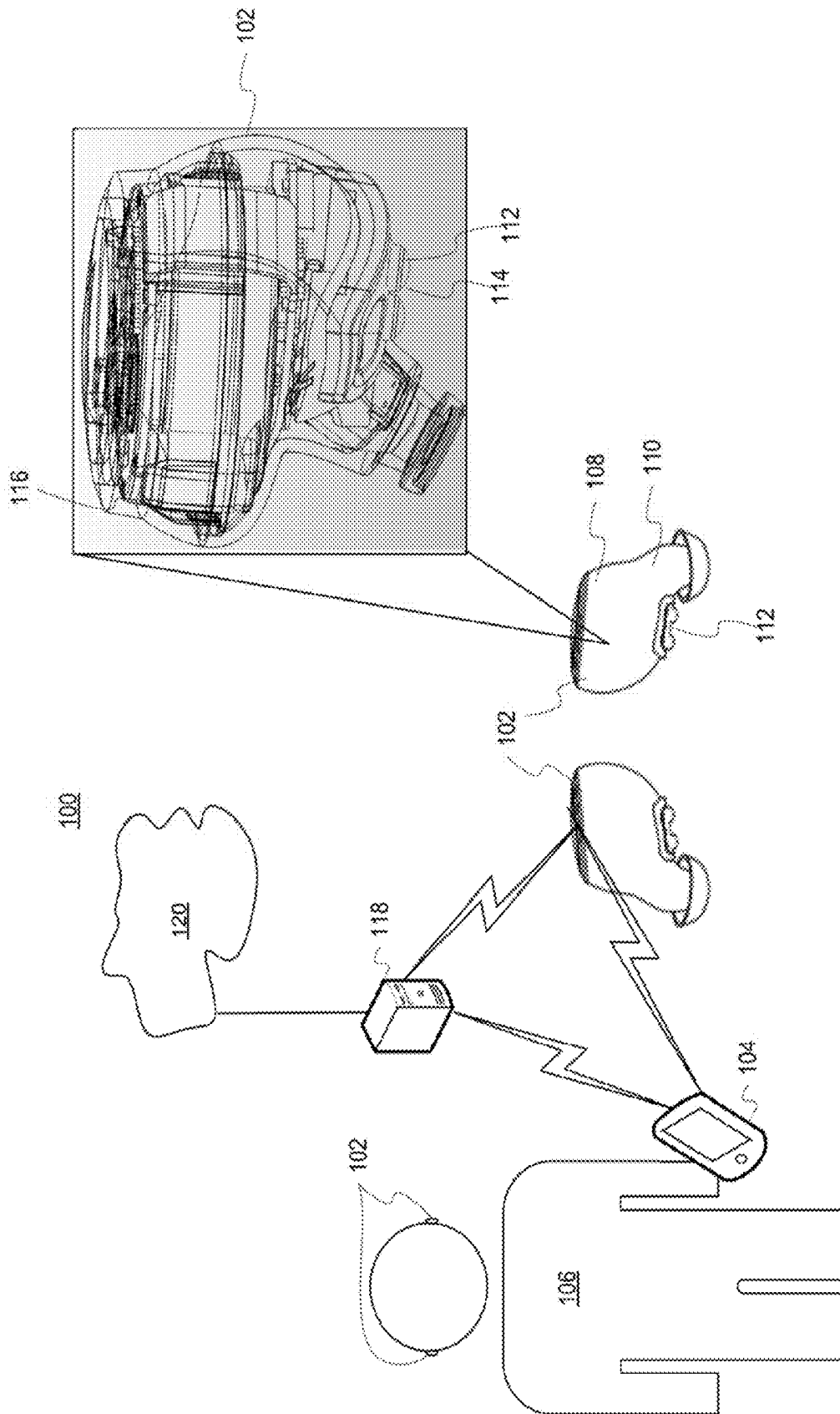

FIG. 1

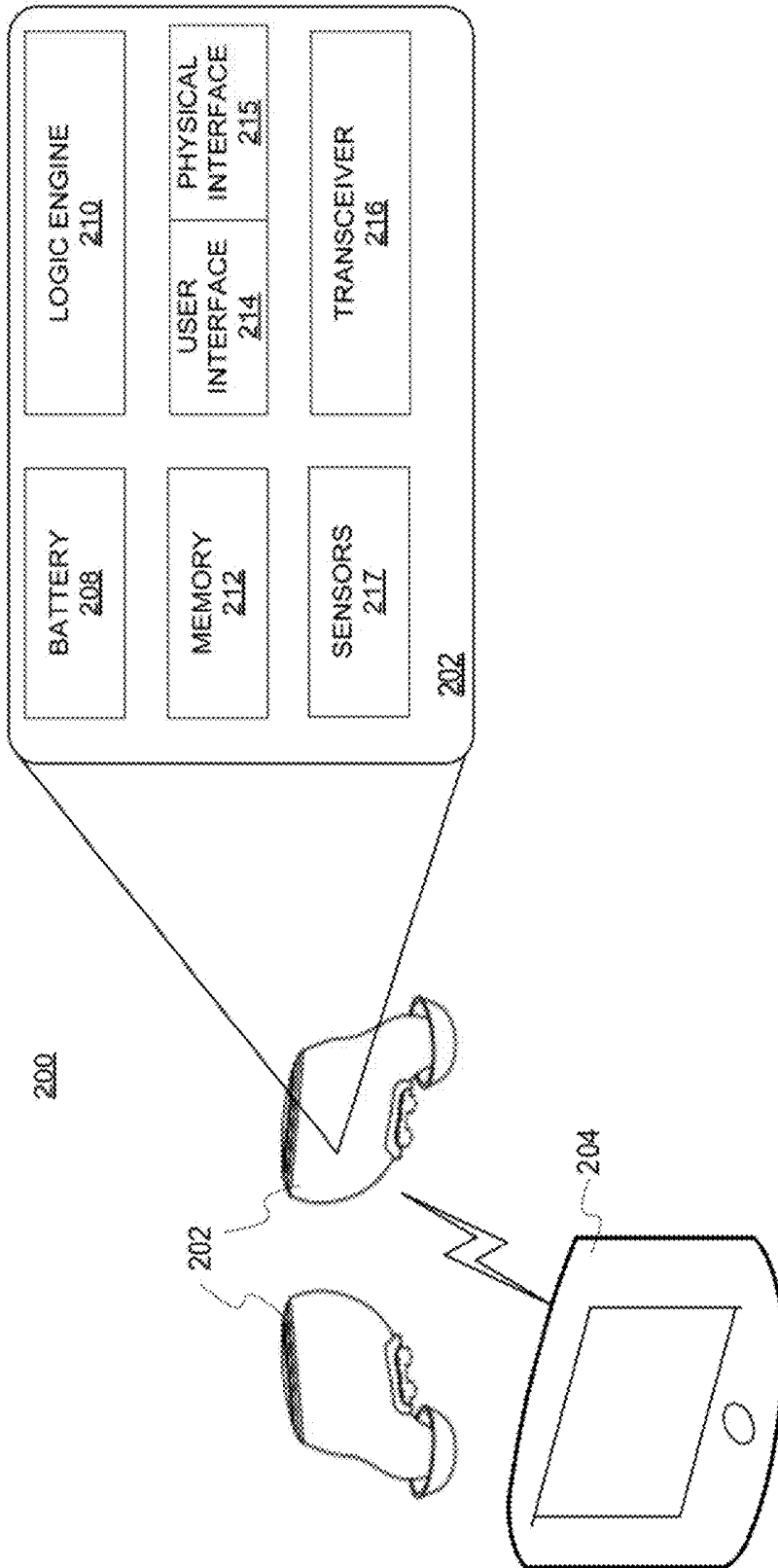

FIG. 2

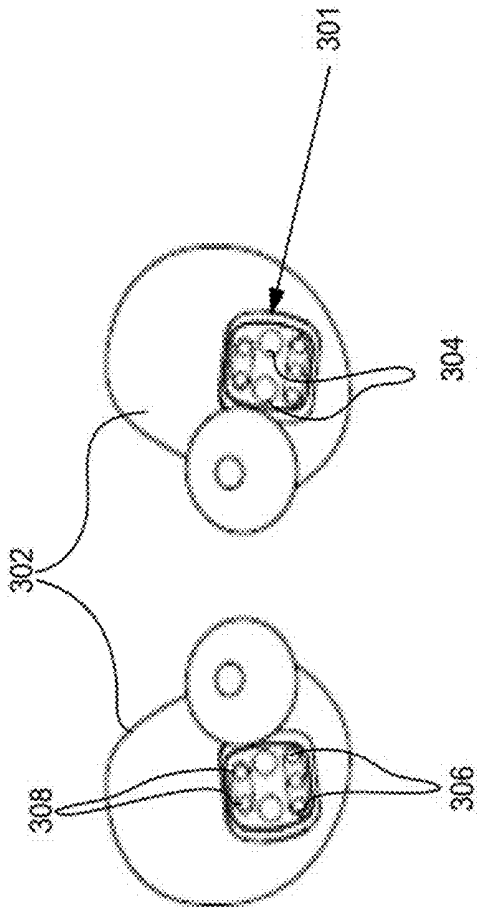

FIG. 3

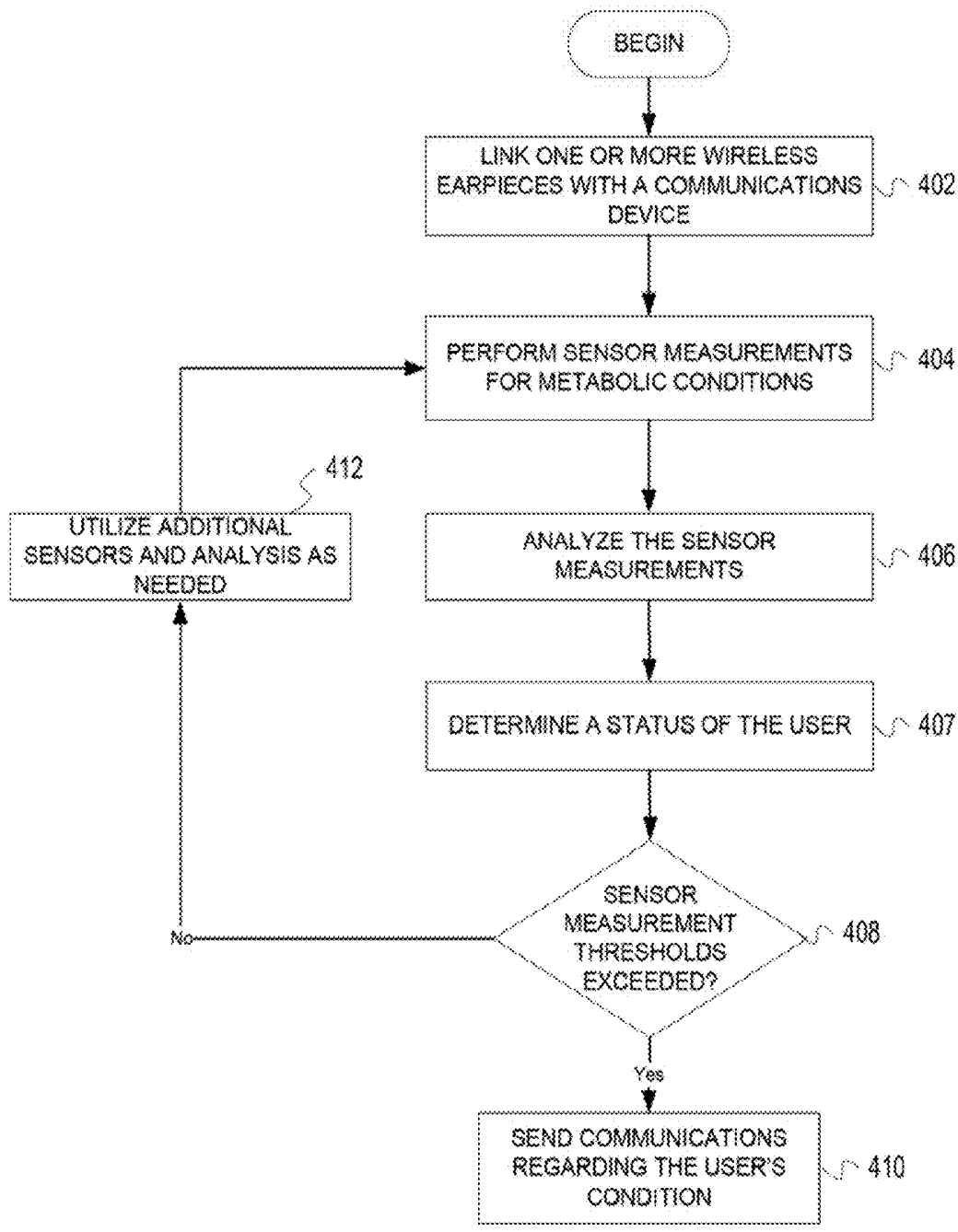

FIG. 4

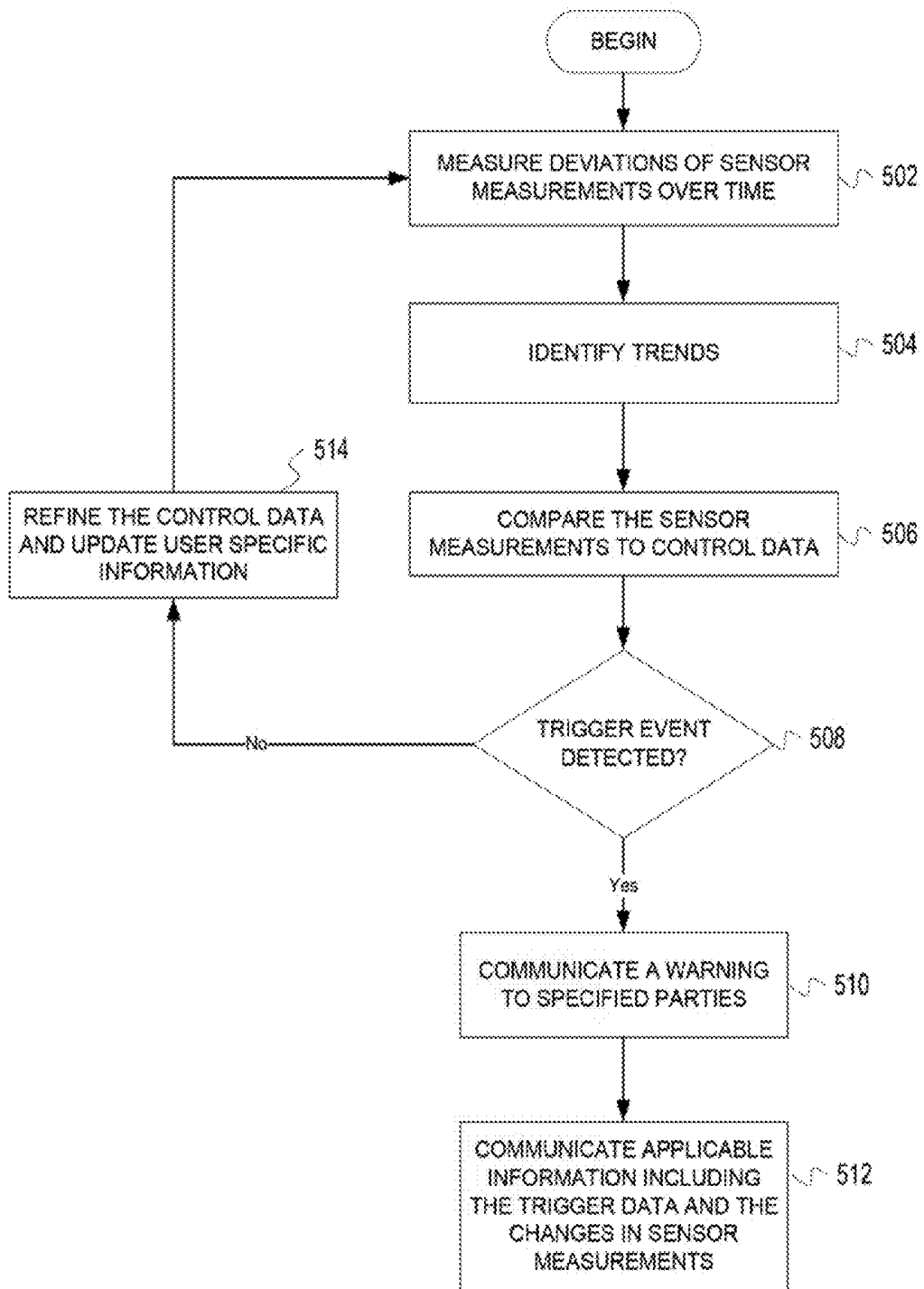

FIG. 5

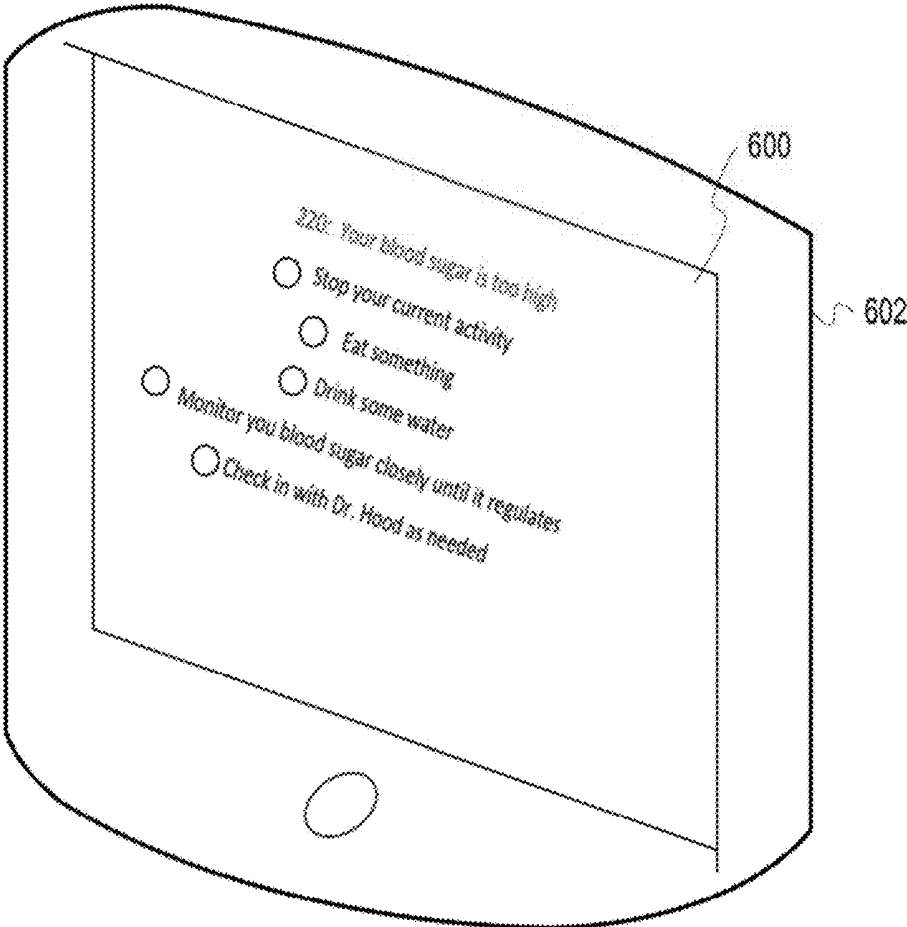

FIG. 6

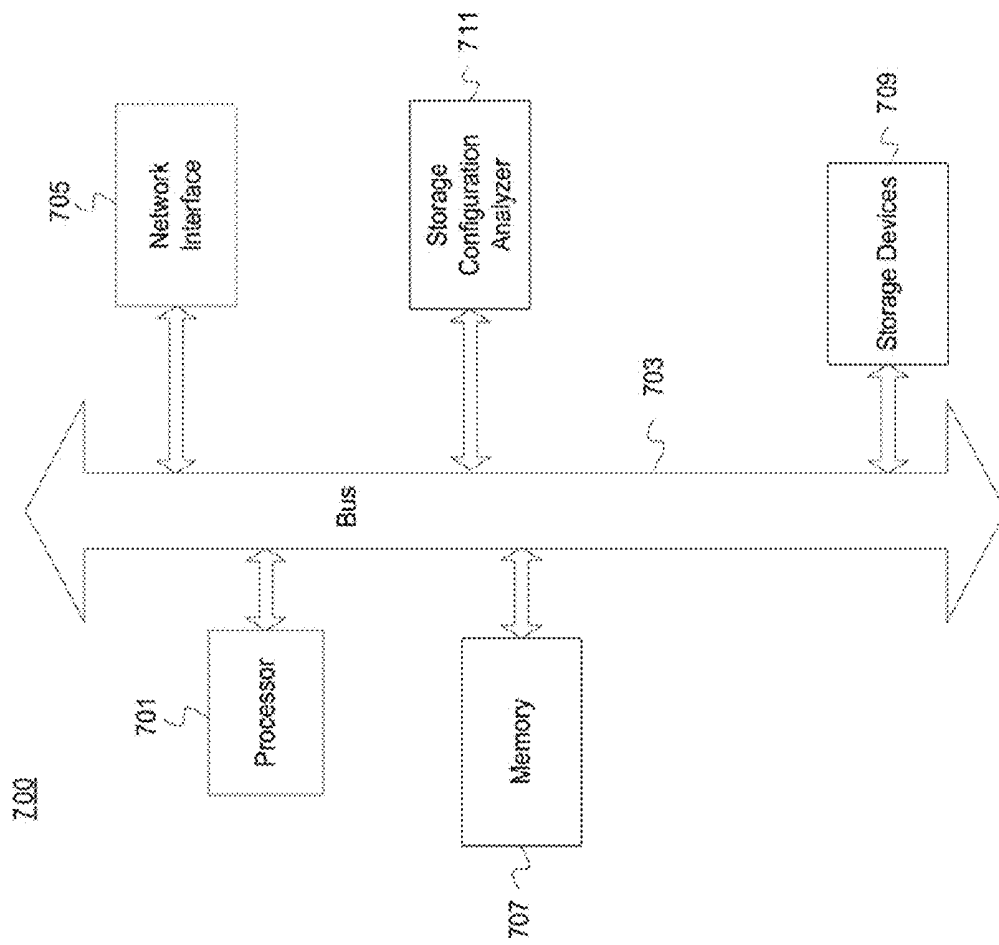

FIG. 7

DETECTION OF METABOLIC DISORDERS USING WIRELESS EARPIECES

PRIORITY STATEMENT

[0001] This application claims priority to U.S. Provisional Patent Application 62/358,764, filed on Jul. 6, 2016, and entitled DETECTION OF METABOLIC DISORDERS USING WIRELESS EARPIECES, hereby incorporated by reference in its entirety.

BACKGROUND

I. Field of the Disclosure

[0002] The illustrative embodiments relate to wireless earpieces. More specifically, but not exclusively, the illustrative embodiments relate to wireless earpieces for detecting metabolic disorders and monitoring user biometrics and input.

II. Description of the Art

[0003] The growth of wearable devices is increasing exponentially. This growth is fostered by the decreasing size of microprocessors, circuitry boards, chips, and other components. In some cases, wearable devices may obtain biometric data. An important aspect of biometric data is monitoring metabolic abnormalities. In some cases, detecting metabolic abnormalities may be difficult because of the small changes over time, location, user activity, and access to equipment or devices that may be configured to detect such conditions.

SUMMARY OF THE DISCLOSURE

[0004] One embodiment of the illustrative embodiments provides a system, method, and wireless earpieces for determining the status of the user. Sensor measurements of the user are performed utilizing at least optical sensors of the wireless earpieces. The sensor measurements are analyzed. The status of the user is determined utilizing at least the sensor measurements of the optical sensors of the wireless earpieces. An alert is communicated to the user in response to there being a change in the status of the user. Another embodiment provides wireless earpieces including a processor and a memory storing a set of instructions. The set of instructions are executed to perform the method described.

[0005] Another embodiment provides a wireless earpiece. The wireless earpiece may include a frame for fitting in an ear of a user. The wireless earpiece may also include a logic engine controlling functionality of the wireless earpiece. The wireless earpiece may also include a number of sensors measuring biometric readings of the user. The sensors may include at least optical sensors. The wireless earpiece may also include a transceiver communicating with at least a wireless device. The logic engine analyzes the biometric readings, determines a status of the user utilizing the biometric readings from the optical sensors, and communicates an alert to the user in response to there being a change in the status of the user.

BRIEF DESCRIPTION OF THE DRAWINGS

[0006] Illustrated embodiments of the present invention are described in detail below with reference to the attached drawing figures, which are incorporated by reference herein, and where:

[0007] FIG. 1 is a pictorial representation of a communication system in accordance with an illustrative embodiment;

[0008] FIG. 2 is a block diagram of wireless earpieces in accordance with an illustrative embodiment;

[0009] FIG. 3 is a pictorial representation of sensors of the wireless earpieces in accordance with illustrative embodiments;

[0010] FIG. 4 is a flowchart of a process for determining a condition of a user utilizing wireless earpieces in accordance with an illustrative embodiment;

[0011] FIG. 5 is a flowchart of a process for monitoring a user utilizing wireless earpieces in accordance with an illustrative embodiment;

[0012] FIG. 6 is a pictorial representation of a display in accordance with an illustrative embodiment; and

[0013] FIG. 7 depicts a computing system in accordance with an illustrative embodiment.

DETAILED DESCRIPTION OF THE DISCLOSURE

[0014] The illustrative embodiments provide a system, method, wireless earpieces, and personal area network for determining user biometrics including metabolic disorders. The wireless earpieces may include any number of sensors for measuring blood oxygenation, chemical compounds present within or excreted by the user, blood pressure, respiration, temperature, pulse rate, and associated changes in the sensor measurements. In response to detecting a metabolic abnormality associated with one or more thresholds, an alert may be communicated to the user through the wireless earpieces or to the user or other designated parties through one or more additional computing or communications devices.

[0015] The wireless earpieces may also be utilized to control, communicate, manage, or interact with a number of other wearable devices, such as smart glasses, helmets, smart glass, watches or wrist bands, chest straps, implants, displays, clothing, or so forth. In one embodiment, the wireless earpieces may be part of a personal area network. A personal area network is a network for data transmissions among devices, such as personal computing, communications, camera, vehicles, entertainment, and medical devices. The personal area network may utilize any number of wired, wireless, or hybrid configurations and may be stationary or dynamic. For example, the personal area network may utilize wireless network protocols or standards, such as INSTEON, IrDA, Wireless USB, near field magnetic induction (NFMI), Bluetooth, Z-Wave, ZigBee, Wi-Fi, ANT+ or other applicable radio frequency signals. In one embodiment, the personal area network may move with the user.

[0016] The wireless earpieces may include any number of sensors for reading user biometrics, such as pulse rate, blood pressure, blood oxygenation, temperature, calories expended, blood or sweat chemical content, voice and audio output, impact levels, and orientation (e.g., body, head, etc.). The sensors may also determine the user's location, position, velocity, impact levels, and so forth. The sensors may also receive user input and convert the user input into commands or selections made across the personal devices of the personal area network. For example, the user input detected by the wireless earpieces may include voice commands, head motions, finger taps, finger swipes, motions or gestures, or other user inputs sensed by the wireless earpieces. The user

input may be determined and converted into commands that may be sent to one or more external devices, such as a tablet computer, smart phone, or so forth.

[0017] The wireless earpieces may perform sensor measurements for the user to read any number of user biometrics. The user biometrics may be analyzed including measuring deviations or changes of the sensor measurements over time, identifying trends of the sensor measurements, and comparing the sensor measurements to control data for the user. As the sensor measurements are analyzed, analysis is performed to determine whether they exceed one or more thresholds. The thresholds may be set by default, the user, an administrator, a caregiver, or other parties. The thresholds may include a high threshold and a low threshold (e.g., temperature, blood pressure, heart rate, etc.) that may be utilized to determine whether an event is automatically triggered by the wireless earpieces. The event may include a communication to the user including a warning that a threshold has been exceeded. The warning may also specify the user's biometrics or sensor readings that triggered the event as well as the thresholds themselves so that the user may be alerted. The warning may include information, such as trends in sensor measurements, potential condition of the user, and other applicable information.

[0018] In one embodiment, the sensors of the wireless earpieces may detect metabolic abnormalities, a critical factor in providing appropriate diagnosis and treatment to users. In some cases, metabolic abnormalities progress slowly without causing appreciable discomfort or distress on the part of the patient. In other cases, the onset of metabolic abnormalities may be quite rapid and the consequences of non-diagnosis or delayed diagnosis may lead to significant issues with morbidity or even mortality. One such example of a need for rapid diagnosis of a disease state involves diabetic ketoacidosis. Diabetic ketoacidosis may be characterized by the development of high concentrations of ketone bodies in the bloodstream. Ketones are the byproducts of the breakdown of fatty-acids by the body. Ketones may rapidly accumulate in the bloodstream with the most common types being beta-hydroxybutyrate and acetoacetic acid. The metabolic state of ketoacidosis may be caused by the body's inability to adequately regulate ketone production which may lead to acidification of the blood pH and metabolic acidosis. The various types of metabolic abnormalities may present a serious threat to the well-being of the patient. For example, rapid diagnosis of ketoacidosis is essential to successful intervention thereby minimizing increased risks of morbidity and mortality.

[0019] In one embodiment, ketones may be detected in the sweat or excretions of the user as detected by the sensors of the wireless earpieces. Other metabolic disorders may cause pigmentary changes in the skin. One such example is hyperbilirubinemia. Bilirubin may accumulate in the blood stream due to the breakdown of red blood cells. When red blood cells break down, bilirubin (a tetrapyrrole) is produced through the breakdown of hemoproteins such as hemoglobin. If the bilirubin level is too high, deposition of the yellow colored bilirubin pigments occur in multiple tissues, such as the skin, sclerae, and other tissues, such as the mucous membranes. These changes may cause an icteric appearance to the skin through a gradual yellowing pigmentation. It is imperative to identify the signs of icterus. The sensors may sense changes to the pigments of the skin associated with ketones. The sensor may be positioned

within the earpiece so that it is in contact with the skin. The sensor itself may be an optical sensor such as a single fiber optic sensor coupled to a light source such as a blue light source because bilirubin absorbs blue light.

[0020] The wireless earpieces may include any number of biometric sensors for monitoring and detecting metabolic states. For example, an optical sensor utilizing a blue LED may be useful for detecting yellow pigments associated with elevated levels of bilirubin. The blue LEDs (or other optical, spectroscopy sensors) may directly contact the epithelium of the external auditory canal or auricular regions. As a result, the bilirubin levels may be monitored in real-time without the need for blood draws to determine the status of the user. The wireless earpieces may also detect ketones, such as the acidification of sweat that may be an indicator of the emergence of such a condition. The wireless earpieces may also include chemical sensors that may measure chemicals in the sweat and other excretions of the user. The wireless earpieces may also be configured to be blown on by the user to detect ketones in the breath of the user.

[0021] FIG. 1 is a pictorial representation of a communications environment 100 in accordance with an illustrative embodiment. The wireless earpieces 102 may be configured to communicate with each other and with one or more wireless devices, such as a wireless device 104 or a tracking device 118. The wireless earpieces 102 may be worn by a user 106 and are shown as worn and separately from their positioning within the ears of the user 106 for purposes of visualization. A block diagram of the wireless earpieces 102 is further shown in FIG. 2 to further illustrate components and operation of the wireless earpieces 102.

[0022] In one embodiment, the wireless earpieces 102 includes a frame 108 shaped to fit substantially within the ears of the user 106. The frame 108 is a support structure that at least partially encloses and houses the electronic components of the wireless earpieces 102. The frame 108 may be composed of a single structure or multiple structures that are interconnected. The frame 108 defines an extension 110 configured to fit substantially within the ear of the user 106. The extension 110 may include one or more speakers or vibration components for interacting with the user 106. The extension 110 may be removable covered by one or more sleeves. The sleeves may be changed to fit the size and shape of the user's ears. The sleeves may come in various sizes and have extremely tight tolerances to fit the user 106 and one or more other users that may utilize the wireless earpieces 102 during their expected lifecycle. In another embodiment, the sleeves may be custom built to support the interference fit utilized by the wireless earpieces 102 while also being comfortable while worn. The sleeves are shaped and configured to not cover various sensor devices of the wireless earpieces 102.

[0023] In one embodiment, the frame 108 or the extension 110 (or other portions of the wireless earpieces 102) may include sensors 112 for sensing pulse, blood oxygenation, temperature, voice characteristics, skin conduction, glucose levels, impacts, activity level, position, location, orientation, as well as any number of internal or external user biometrics. In other embodiments, the sensors 112 may be internally positioned within the wireless earpieces 102. For example, the sensors 112 may represent metallic contacts, optical interfaces, or micro-delivery systems for receiving and delivering information. Small electrical charges may be passed through the sensors 112 to analyze the biometrics of

the user **106** including pulse, skin conductivity, blood analysis, sweat levels, and so forth. Sensors **112** may also be utilized to sense or provide a small electrical current which may be useful for alerting the user, stimulating blood flow, alleviating nausea, or so forth.

[0024] In some applications, temporary adhesives or securing mechanisms (e.g., clamps, straps, lanyards, extenders, etc.) may be utilized to ensure that the wireless earpieces **102** remain in the ears of the user **106** even during the most rigorous and physical activities or that if they do fall out they are not lost or broken. For example, the wireless earpieces **102** may be utilized during marathons, swimming, team sports, biking, hiking, parachuting, or so forth. The wireless earpieces **102** may be configured to play music or audio, receive and make phone calls or other communications, determine ambient environmental conditions (e.g., temperature, altitude, location, speed, heading, etc.), read user biometrics (e.g., heart rate, motion, temperature, sleep, blood oxygenation, voice output, calories burned, forces experienced, etc.), and receive user input, feedback, or instructions. The wireless earpieces **102** may be utilized with any number of automatic assistants, such as Siri, Cortana, or other smart assistant.

[0025] The communications environment **100** may further include a tracking device **118**. The tracking device **118** may communicate with one or more wired or wireless networks, such as a network **120**. The tracking device **118** may represent any number of devices, systems, equipment, or components, such as a point of personal computer, server, tablet, medical system, or so forth. The tracking device **118** may communicate utilize any number of standards, protocols, or processes. For example, the tracking device **118** may utilize a wired or wireless connection to communicate with the wireless earpieces **102**, the wireless device **104**, or other electronic devices. The tracking device **118** may utilize any number of memories or databases to store biometric information associated with the user **106** including

[0026] The wireless earpieces **102** may determine their position with respect to each other as well as the wireless device **104** and the tracking device **118**. For example, position information for the wireless earpieces **102** and the wireless device **104** may determine proximity of the devices in the communications environment **100**. For example, global positioning information or signal strength/activity may be utilized to determine proximity and distance of the devices to each other in the communications environment **100**. In one embodiment, the distance information may be utilized to determine whether biometric analysis may be displayed to a user. For example, the wireless earpieces **102** may be required to be within four feet of the wireless device **104** and the tracking device **118** in order to display biometric readings or receive user input.

[0027] In one embodiment, the wireless earpieces **102** and the corresponding sensors **112** (whether internal or external) may be configured to take a number of measurements or log information during normal usage. The sensor measurements may be utilized to extrapolate other measurements, factors, or conditions applicable to the user **106**. For example, the sensors **112** may monitor the user's ketone levels to determine real-time metabolic conditions as well as to monitor the daily, weekly, or yearly patterns and characteristics to determine the user's status. The user **106** or another party may configure the wireless earpieces **102** directly or through a connected device and app (e.g., mobile app with a graphi-

cal user interface) to store or share biometric information, audio, readings, and other data. Some examples of standard usage may include detecting and recording a heartbeat, tracking ketone levels per time period (e.g., minutes, hours, etc.) or based on certain events or thresholds.

[0028] The user **106** or another party may also utilize the wireless device **104** to associate biometric information and conditions with the actual or perceived status of the user **106**. For example, ketone or hyperbilirubinemia levels may be associated with the condition of the user **106** as determined by a medical professional or as characterized by the user. As a result, the wireless earpieces **102** may be adjusted or trained over time to become even more accurate in reading biometric information of the user **106**. The wireless earpieces **102** may utilize historical information to generate default values, baselines, thresholds, policies, or settings for determining when and how the user's biometric identifiers are read. As a result, the wireless earpieces may more accurately diagnose the metabolic status of the user **106**.

[0029] The wireless earpieces **102** may include any number of sensors **112** and logic for measuring and determining user biometrics, such as pulse rate, skin conduction, blood oxygenation, temperature, calories expended, blood or excretion chemistry, voice and audio output, position, and orientation (e.g., body, head, etc.). The sensors **112** may also determine the user's location, position, velocity, impact levels, and so forth. The sensors **112** may also receive user input and convert the user input into commands or selections made across the personal devices of the personal area network. For example, the user input detected by the wireless earpieces **102** may include voice commands, head motions, finger taps, finger swipes, motions or gestures, or other user inputs sensed by the wireless earpieces. The user input may be determined by the wireless earpieces **102** and converted into authorization commands that may be sent to one or more external devices, such as the wireless device **104**, the tracking device **118**, a tablet computer, or so forth. For example, the user **106** may create a specific head motion and voice command that when detected by the wireless earpieces **102** are utilized to initiate biometric readings, such as checking the status of the user **106**. The wireless earpieces **102** may perform any number of non-invasive or invasive processes or procedures (e.g., taking a blood sample to measure chemical compositions).

[0030] The sensors **112** may make all of the measurements with regard to the user **106** or may communicate with any number of other sensory devices in the communications environment **100** to measure information and data about the user **106** as well as the communications environment **100** itself. In one embodiment, the communications environment **100** may represent all or a portion of a personal area network. The wireless earpieces **102** may be utilized to control, communicate, manage, or interact with a number of other wearable devices or electronics, such as smart glasses, helmets, smart glass, watches or wrist bands, other wireless earpieces, chest straps, implants, displays, clothing, or so forth. A personal area network is a network for data transmissions among devices, such as personal computing, communications, camera, vehicles, entertainment, and medical devices. The personal area network may utilize any number of wired, wireless, or hybrid configurations and may be stationary or dynamic. For example, the personal area network may utilize wireless network protocols or standards, such as INSTEON, IrDA, Wireless USB, Bluetooth,

Z-Wave, ZigBee, Wi-Fi, ANT+ or other applicable radio frequency signals. In one embodiment, the personal area network may move with the user **106**.

[0031] In other embodiments, the communications environment **100** may include any number of devices, components, or so forth that may communicate with each other directly or indirectly through a wireless (or wired) connection, signal, or link. The communications environment **100** may include one or more networks and network components and devices represented by the network **120**, such as routers, servers, signal extenders, intelligent network devices, computing devices, or so forth. In one embodiment, the network **120** of the communications environment **100** represents a personal area network as previously disclosed. The network **120** may also be a health network including devices and processes for simultaneously monitoring the health of a number of users.

[0032] Communications within the communications environment **100** may occur through the network **120** or a Wi-Fi network or may occur directly between devices, such as the wireless earpieces **102** and the wireless device **104**. The network **120** may communicate with or include a wireless network, such as a Wi-Fi, cellular (e.g., 3G, 4G, 5G, PCS, GSM, etc.), Bluetooth, or other short range or long range radio frequency networks. The network **120** may also include or communicate with any number of hard wired networks, such as local area networks, coaxial networks, fiber-optic networks, network adapters, or so forth. Communications within the communications environment **100** may be operated by one or more users, service providers, or network providers.

[0033] The wireless earpieces **102** may play, communicate, or utilize any number of alerts or communications to indicate that the status of the user. For example, one or more alerts may indicate when health and metabolic tracking is pending, in process, authorized, and/or alerted with specific tones, verbal acknowledgements, tactile feedback, or other forms of communicated messages. For example, an alert may be played during each stage of the tracking. The corresponding alert may also be communicated to the user **106**, the wireless device **104**, and the tracking device **118**.

[0034] In other embodiments, the wireless earpieces **102** may also vibrate, flash, play a tone or other sound, or give other indications of the health status of the user in order to prompt user actions (e.g., providing additional biometric readings, eat or drink, go to the Doctor, etc.) or implement any number of processes. The wireless earpieces **102** may also communicate an alert to the wireless device **104** that shows up as a notification, message, or other indicator indicating the changed status of the tracking.

[0035] The wireless earpieces **102** as well as the wireless device **104** may include logic for automatically implementing actions in response to a pending tracking or various conditions and factors of the communications environment **100**. For example, the wireless device **104** may communicate instructions received from the wireless earpieces **102** for the user **106** to visit the nurse at school to be checked on. The wireless device **104** may include an application that displays instructions and information to the user **106** in response to the determined status of the user.

[0036] In one embodiment, the wireless device **104** may utilize short-range or long-range wireless communications to communicate with the wireless earpieces **102** through a wireless signal or devices of the communications environ-

ment **100**. For example, the wireless device **104** may include a Bluetooth and cellular transceiver within the embedded logical components. For example, the wireless signal may be a Bluetooth, Wi-Fi, Zigbee, Ant+, near-field magnetic induction (NFMI), or other short range wireless communication.

[0037] The wireless device **104** may represent any number of wireless or wired electronic communications or computing devices, such as smart phones, laptops, desktop computers, control systems, tablets, displays, gaming devices, music players, personal digital assistants, vehicle systems, or so forth. The wireless device **104** may communicate utilizing any number of wireless connections, standards, or protocols (e.g., near field communications, NFMI, Bluetooth, Wi-Fi, wireless Ethernet, etc.). For example, the wireless device **104** may be a touch screen cellular phone that communicates with the wireless earpieces **102** utilizing Bluetooth communications. The wireless device **104** may implement and utilize any number of operating systems, kernels, instructions, or applications that may make use of the available sensor data sent from the wireless earpieces **102**. For example, the wireless device **104** may represent any number of android, iOS, Windows, open platforms, or other systems and devices. Similarly, the wireless device **104** or the wireless earpieces **102** may execute any number of applications that utilize the user input, proximity data, biometric data, and other feedback from the wireless earpieces **102** to initiate, authorize, or process health tracking and perform the associated tasks.

[0038] As noted, the layout of the internal components of the wireless earpieces **102** and the limited space available for a product of limited size may affect where the sensors **112** may be positioned. The positions of the sensors **112** within each of the wireless earpieces **102** may vary based on the model, version, and iteration of the wireless earpiece design and manufacturing process.

[0039] FIG. 2 further illustrates a block diagram of the wireless earpieces **202**. As noted, the components of the wireless earpieces **202** may be described collectively rather than individually. The wireless earpieces **202** may be wirelessly linked to any number of wireless devices, such as the wireless device **104** of FIG. 1. For example, wireless devices may include wearable devices, communications devices, computers, entertainment devices, vehicle systems, exercise equipment, or so forth. Sensor measurements, user input, and commands may be received from either the wireless earpieces **202** or the wireless device (not shown) for processing and implementation on either of the devices (or other externally connected devices). Reference to the wireless earpieces **202** may descriptively or functionally refer to either the pair of wireless earpieces (wireless earpieces) or individual wireless earpieces (left wireless earpiece and right wireless earpiece) without limitation.

[0040] In some embodiments, the wireless device may also act as a logging tool for sensor data or measurements made by the wireless earpieces **202**. For example, the wireless device may receive and share data captured by the wireless earpieces **202** in real-time including biometric information, such as a tracking biometrics or input or status of the user (e.g., physical, emotional, etc.). As a result, the wireless device may be utilized to store, display, and synchronize sensor data received from the wireless earpieces **202**. For example, the wireless device may display user pulse rate, temperature, ketone levels, proximity, location, blood oxygenation, distance, calories burned, and so forth as

measured by the wireless earpieces 202. The wireless device may be configured to receive and display alerts that indicate conditions to initiate, process, and track a user's condition or specific symptoms. For example, if a metabolic state is detected based on ketones thresholds, the wireless earpieces 202 may automatically display an alert, message, or in-app communication, such as "please verify your metabolic condition, you may need medical treatment based on your detected ketone levels." The wireless earpieces 202 and the wireless device may have any number of electrical configurations, shapes, and colors and may include various circuitry, connections, and other components utilized to perform the illustrative embodiments.

[0041] In one embodiment, the wireless earpieces 202 may include a battery 208, a logic engine 210, a memory 212, a user interface 214, a physical interface 215, a transceiver 216, and sensors 217. The wireless earpieces 202 and the wireless device 202 may have any number of configurations and include components and features as are known in the art. In one embodiment, the wireless earpieces 202 may include a module specifically for performing noise cancellation. For example, determinations of noise cancelling signals may be determined in one wireless earpiece and health biometrics may be monitored in the other wireless earpiece, with coordination of determinations, actions, and so forth synchronized between both wireless earpieces 202.

[0042] The battery 208 is a power storage device configured to power the wireless earpieces 202. In other embodiments, the battery 208 may represent a fuel cell, thermal electric generator, piezo electric charger, solar charger, ultracapacitor, or other existing or developing power storage technologies. The sensors 217 may also be utilized to measure the temperature of the battery 208 and the condition of internal components of the wireless earpieces. The sensors may also be utilized to determine data about external conditions and factors applicable to the user, the user's environment, a communicating wireless device, or so forth. Other conditions and factors sensed by the sensors 217 (e.g., water/humidity, pressure, ketone levels, blood oxygenation, blood content levels, altitude, position, impact, radiation, etc.) may also be determined with the data being processed by the logic engine 210.

[0043] The logic engine 210 is the logic that controls the operation and functionality of the wireless earpieces 202. The logic engine 210 may include circuitry, chips, and other digital logic. The logic engine 210 may also include programs, scripts, and instructions that may be implemented to operate the logic engine 210. The logic engine 210 may represent hardware, software, firmware, or any combination thereof. In one embodiment, the logic engine 210 may include one or more processors. The logic engine 210 may also represent an application specific integrated circuit (ASIC) or field programmable gate array (FPGA). The logic engine 210 may utilize sensor measurements, user input, user preferences and settings, conditions, factors, and environmental conditions to determine the identity of the user, at least in part, from measurements performed by the wireless earpieces 202.

[0044] The wireless earpieces 202 may function separately or together to authenticate biometric tracking is allowed by an authorized user. For example, processing may be divided between the wireless earpieces 202 to increase the speed of processing and to load balance any processes being performed. For example, a left wireless earpiece may

perform imaging of the user's ear to identify the user while the right wireless earpiece may measure biometrics and identify voice characteristics of the wireless earpieces. Multiple forms of identifying information may be utilized to better secure information authenticated through the wireless earpieces.

[0045] In one embodiment, the logic engine 210 may determine the metabolic condition based on measurements and data from the sensors 217. The logic engine 210 may also perform any number of mathematical functions (e.g. linear extrapolation, polynomial extrapolation, conic extrapolation, French curve extrapolation, polynomial interpolation) to determine or infer the user biometrics, condition, identity, or other information of the user associated with the sensor measurements. The logic engine 210 may utilize time and other sensor measurements as causal forces to enhance a mathematical function utilized to perform the determinations, processing, and extrapolation performed by the logic engine 210. The logic engine 210 may also utilize historical information from the user/other users to better determine the state, condition, and other information associated with the user. Mathematical analysis of the user's overall physiological status may be determined from pulse rate, pulse rate variability, oxygen saturation, temperature, respiratory rate, systolic and diastolic blood pressure, and so forth.

[0046] The logic engine 210 may also process user input to determine biometric-related commands implemented by the wireless earpieces 202 or sent to the wireless earpieces 202 through the transceiver 216. Specific actions may be allowed, initiated, or implemented based on sensor measurements, extrapolated measurements, environmental conditions, proximity thresholds, and so forth. For example, the logic engine 210 may implement a biometric tracking macro performing a specific battery of tests each morning to determine the user's ketone levels, metabolic state, and overall health status. Various tests and different types of status checks may be performed utilizing a pre-defined schedule. The pre-defined schedule may be set by the user, an administrator of the wireless earpieces, a medical professional, or other authorized party.

[0047] In one embodiment, a processor included in the logic engine 210 is circuitry or logic enabled to control execution of a set of instructions. The processor may be one or more microprocessors, digital signal processors, application-specific integrated circuits (ASIC), central processing units, or other devices suitable for controlling an electronic device including one or more hardware and software elements, executing software, instructions, programs, and applications, converting and processing signals and information, and performing other related tasks.

[0048] The memory 212 is a hardware element, device, or recording media configured to store data or instructions for subsequent retrieval or access at a later time. The memory 212 may represent static or dynamic memory. The memory 212 may include a hard disk, random access memory, cache, removable media drive, mass storage, or configuration suitable as storage for data, instructions, and information. In one embodiment, the memory 212 and the logic engine 210 may be integrated. The memory may use any type of volatile or non-volatile storage techniques and mediums. The memory 212 may store information related to the user, wireless earpieces 202, wireless device 204, and other peripherals, such as a wireless device, smart glasses, smart watch, smart

case for the wireless earpieces **202**, wearable device, and so forth. In one embodiment, the memory **212** may display or communicate instructions, programs, drivers, or an operating system for controlling the user interface **214** including one or more LEDs or other light emitting components, speakers, tactile generators (e.g., vibrator), and so forth. The memory **212** may also store biometric readings, user input required for specified tracking processes, biometric tracking settings and preferences, thresholds, conditions, signal or processing activity, historical information, proximity data, and so forth.

[0049] The transceiver **216** is a component comprising both a transmitter and receiver which may be combined and share common circuitry on a single housing. The transceiver **216** may communicate utilizing NFMI, Bluetooth, Wi-Fi, ZigBee, Ant+, near field communications, wireless USB, infrared, mobile body area networks, ultra-wideband communications, cellular (e.g., 3G, 4G, 5G, PCS, GSM, etc.), infrared, or other suitable radio frequency standards, networks, protocols, or communications. For example, the transceiver **216** may coordinate communications and actions between the wireless earpieces **202** utilizing NFMI communications. The transceiver **216** may also be a hybrid, dual, or multi-mode transceiver that supports a number of different communications simultaneously. For example, the transceiver **216** may communicate with wireless devices or other systems utilizing wired interfaces (e.g., wires, traces, etc.), NFC or Bluetooth communications. The transceiver **216** may also detect amplitudes and infer distance between the wireless earpieces **202** and external devices, such as the wireless device or a smart case of the wireless earpieces **202**.

[0050] The components of the wireless earpieces **202** may be electrically connected utilizing any number of wires, contact points, leads, busses, wireless interfaces, or so forth. In addition, the wireless earpieces **202** may include any number of computing and communications components, devices or elements which may include busses, motherboards, circuits, chips, sensors, ports, interfaces, cards, converters, adapters, connections, transceivers, displays, antennas, and other similar components.

[0051] The physical interface **215** is hardware interface of the wireless earpieces **202** for connecting and communicating with wireless devices or other electrical components, devices, or systems. The physical interface **215** may include any number of pins, arms, or connectors for electrically interfacing with the contacts or other interface components of external devices or other charging or synchronization devices. For example, the physical interface **215** may be a micro USB port. In one embodiment, the physical interface **215** is a magnetic interface that automatically couples to contacts or an interface of a wireless device. In another embodiment, the physical interface **215** may include a wireless inductor for charging the wireless earpieces **202** without a physical connection to a charging device.

[0052] The user interface **214** is a hardware interface for receiving commands, instructions, or input through the touch (haptics) of the user, voice commands, or predefined motions. For example, the user interface **214** may include a touch screen, one or more cameras or image sensors, microphones, speakers, and so forth. The user interface **214** may be utilized to control the other functions of the wireless earpieces **202**. The user interface **214** may include the LED array, one or more touch sensitive buttons or portions, a miniature screen or display, or other input/output compo-

ments. The user interface **214** may be controlled by the user or based on commands received from the wireless device. For example, the user may turn on, reactivate, or provide feedback utilizing the user interface **214**, such as an application executed by the logic engine **210** and displayed by a touch screen of the user interface **214** to display information and receive user selections and feedback.

[0053] In one embodiment, the user interface **214** may include a fingerprint scanner that may be utilized to scan a fingerprint (e.g., the index finger) of a user to authenticate biometric readings and reporting. The user interface **214** of each of the wireless earpieces **202** may store identifying information for one or more fingers. In one embodiment, the biometric data of the user may be encrypted and stored within a secure portion of the memory **212** to prevent unwanted access or hacking. The wireless earpieces **202** may also store additional important biometric data, such as medical information (e.g., medical conditions, allergies, logged biometrics, contacts, etc.) that may be shared regularly, in response to threshold conditions being met, or in response to an emergency. The wireless earpieces **202** may also include one or more external microphones for playing alerts or providing information to external parties.

[0054] In one embodiment, the user may provide user feedback for authenticating a biometric reading, specified action, or authorization by tapping the user interface **214** once, twice, three times, or any number of times. Similarly, a swiping motion may be utilized across or in front of the user interface **214** (e.g., the exterior surface of the wireless earpieces **202**) to implement a predefined action. Swiping motions in any number of directions or gestures may be associated with specific actions as well as other activities, such as share exercise data, share music playlist, share vitals, play music, pause, fast forward, rewind, activate a digital assistant (e.g., Siri, Cortana, smart assistant, etc.), or so forth without limitation. The swiping motions may also be utilized to control actions and functionality of wireless devices or other external devices (e.g., smart television, camera array, smart watch, etc.). The user may also provide user input for authenticating an action by moving his head in a particular direction or motion or based on the user's position or location. For example, the user may utilize voice commands, head gestures, or touch commands to change the content visually displayed by the wireless device **20** or audibly communicated by the wireless earpieces **202**. The user interface **214** may also provide a software interface including any number of icons, soft buttons, windows, links, graphical display elements, and so forth.

[0055] In one embodiment, the user interface **214** may periodically utilize one or more microphones and speakers of the wireless earpieces to authenticate the user. The microphone of the user interface **214** may measure various voice characteristics including amplitude, shimmer rates (i.e., changes in amplitude over time) frequency/pitch, jitter rates (i.e., changes in frequency data over time), accent, voice speed, inflection, and so forth. The wireless earpieces **202** may also recognize a pre-defined vocabulary. For example, specific words may be required to authenticate different tracking types.

[0056] The sensors **217** may include pulse oximeters, accelerometers, gyroscopes, magnetometers, water, moisture, or humidity detectors, impact/force detectors, chemical sensors (e.g., analysis of sweat, blood, etc.), thermometers, inertial sensors, photo detectors, miniature cameras, micro-

phones, and other similar instruments for detecting the user's status as well as location, utilization of the wireless earpieces 202, orientation, motion, and so forth. The sensors 217 may also be utilized to determine the biometric, activity, location, and speed measurements of the user. In one embodiment, the sensors 217 may store data that may be shared with other components (e.g., logic engine 210), users, and devices.

[0057] The sensors 217 may include photodetectors, ultrasonic mapping devices, or radar that scan the ear of the user when positioned for utilization. The sensors 217 may generate a two or three dimensional scan or topography map of the user's ear and surrounding areas when the wireless earpieces 202 are properly positioned. The mapping may include the internal and/or external portions of the user's ear. The topographical image of the user's ear may be utilized as a stand-alone biometric identifier or may be utilized with other biometric identifiers to identify the user. The image may include the external auditory meatus, scapha, fossa triangularis, scaphoid fossa, helix, antihelix, antitragus, lobule, the tragus, and pinna as well as other internal or external portions of the ear and surrounding head structure.

[0058] Externally connected wireless devices may include components similar in structure and functionality to those shown for the wireless earpieces 202. For example, the wireless device 204 may include any number of processors, batteries, memories, busses, motherboards, chips, transceivers, peripherals, sensors, displays, cards, ports, adapters, interconnects, sensors, and so forth. In one embodiment, the wireless device 204 may include one or more processors and memories for storing instructions. The instructions may be executed as part of an operating system, application, browser, or so forth to implement the features herein described. For example, the user may set preferences for the wireless earpieces 202 to work individually or jointly to identify user biometrics for comparison against known values to determine the user's status or identify variations or abnormalities that may be associated with specific conditions, sicknesses, diseases, identifiers, warnings, or other information. Likewise, the preferences may manage the actions taken by the wireless earpieces 202 in response to identifying specific users are utilizing the wireless earpieces 202. For example, a parent user may have full access to schedule any number of biometric readings for a child that utilizes the wireless earpieces 202 with the results reported directly to one or more of the parents. Results of the user's metabolic state may also be automatically sent to a medical professional for association with the user. The data may be analyzed in real-time or logged to provide a history of measurements for determining trends or statistical results.

[0059] The wireless device may also execute an application with settings or conditions for updating, synchronizing, sharing, saving, processing, and utilizing biometric information. For example, one of the sensors 217 that may have failed may be ignored in response to improper or unreliable data being gathered. As a result, the user identification process for tracking authorization may be dynamically performed utilizing any combination of sensor measurements. For example, the number and position of the sensors 217 utilized to perform status determinations for the user may vary based on failures, inaccurate data, or other temporary or permanent issues with hardware and software of the wireless earpieces 202.

[0060] FIG. 3 is a pictorial representation of sensors 301 of the wireless earpieces 302 in accordance with illustrative embodiments. As previously noted, the wireless earpieces 302 may include any number of internal or external sensors. As shown the sensors 301 are at least partially external to the wireless earpieces 302 for interacting with the skin, excretions, or tissues of the user. The sensors 301 may make independent measurements or combined measurements utilizing the sensory functionality of each of the sensors to measure, confirm, or verify sensor measurements.

[0061] In one embodiment, the sensors 301 may include optical sensors 304, contact sensors 306, and chemical sensors 308. The optical sensors 304 may generate an optical signal that is communicated to the ear (or other body part) of the user and reflected back. The reflected optical signal may be analyzed to determine blood pressure, pulse rate, pulse oximetry, vibrations, blood chemistry, and other information about the user. The optical sensors 304 may include any number of sources for outputting various wavelengths of electromagnetic radiation and visible light. Thus, the wireless earpieces 302 may utilize spectroscopy as it is known in the art and developing to determine any number of user biometrics.

[0062] In one embodiment, the contact sensors 306 may be utilized to perform conductivity, elasticity, and pliability analysis of the user's skin. The contact sensors 306 may measure or provide additional data points and analysis that may indicate the biometric information of the user. The contact sensors 306 may also be utilized to apply electrical, vibrational, motion, or other input, impulses, or signals to the skin of the user.

[0063] The chemical sensors 308 may perform chemical analysis of the user's skin, excretions, blood, or any number of internal or external tissues or samples. In one embodiment, the chemical sensors 308 are non-invasive and may only perform chemical measurements and analysis based on the externally measured and detected factors. In other embodiments, one or more probes, vacuums, capillary action components, needles, or other micro-sampling components may be utilized. Minute amounts of blood or fluid may be analyzed to perform chemical analysis that may be reported to the user and others.

[0064] The sensors 301 may include parts or components that may be periodically replaced or repaired to ensure accurate measurements.

[0065] FIG. 4 is a flowchart of a process for determining a condition of a user utilizing wireless earpieces in accordance with an illustrative embodiment. The process of FIG. 4 may be implemented by one or more wireless earpieces, wearable devices, and any number of other devices communicating directly or through a personal area network. In one embodiment, the process of FIG. 4 may be implemented by one or more wireless earpieces, such as the wireless earpieces 102 of FIG. 1. For example, the method of FIG. 4 may be performed for

[0066] In one embodiment, the process of FIG. 4 may begin by linking one or more wireless earpieces with a communications device (step 402). The wireless earpieces may be linked with the communications device, such as a smart phone, utilizing any number of communications, standards, or protocols. For example, the wireless earpieces may be linked with a cell phone by a Bluetooth connection. The process may require that the devices be paired utilizing an identifier, such as a passcode, password, serial number,

voice identifier, radio frequency, or so forth. The wireless earpieces may be linked with the communications device and any number of other devices directly or through one or more networks, such as a personal area network. In other embodiments, step 402 may not be required to determine the status or condition of a user. For example, any user information may be communicated directly to the user.

[0067] Next, the wireless earpieces perform sensor measurements (step 404). The sensor measurements may include performing any number of biometric measurements. In one embodiment, the sensor measurements include at least optical measurements to determine a metabolic condition of a user. The measurements may measure chemical and pigment levels in the skin, blood, sweat, or other bodily fluids, excretions, or tissues of the user, such as ketone or hyperbilirubinemia levels. For example, the levels may correspond to metabolic, pigmentary, or other conditions, diseases, or health issues the user may be experiencing (whether temporary or permanent). In one embodiment, the optical sensors may utilize a specific wavelength(s) and the corresponding reflections to measure and analyze pigment and chemical levels of the user. Any number of determinations or assumptions may be made based on the sensor measurements. For example, the most common types of ketones detected by the wireless earpieces may include beta-hydroxybutyrate and acetoacetic acid. The sweat of the user, such as detected in the epithelium of the external auditory canal or auricular region of the user's ears may be analyzed for acidification. The levels may be utilized to characterize conditions, such as diabetes, alcoholism, liver disease, forms of cancer, or so forth. The measurements may be performed utilizing a predefined sampling rate (e.g., 1/s, 1/100 ms, 1/min, etc.). Other biometric sensors, such as mechanical (e.g., vibration, elasticity, tension, etc.) or electrical sensors, may perform additional measurements or confirm or verify the measurements. The measurements may also be triggered in response to specific detected events, such as change in user orientation or position (e.g., change from vertical to horizontal position), changes in velocity (e.g., extreme starts, stops, accelerations, etc.), high forces (e.g., impacts, jolts, etc.), or detected events from other sensors worn by the user.

[0068] Next, the wireless earpieces analyze the sensor measurements (step 406). The sensor measurements may be processed or otherwise evaluated by the wireless earpieces. For example, one or more processors of the wireless earpieces may process the incoming data measurements from one or more optical, chemical, mechanical, and/or electrical sensors. The sensor measurements are processed for subsequent analysis, determinations, or decisions, implemented by the wireless earpieces.

[0069] Next, the wireless earpieces determine a status of the user (step 407). In one embodiment, the detected pigment or chemical levels may be compared against baseline, normative, or threshold levels to determine the status of the user. The sensor measurements may also be compared against previous or historical measurements for the user. The overall physiological status of the user may be utilized or determine to enhance the sensor measurements. For example, sensor measurements corresponding to pulse rate, pulse rate variability, oxygen saturation, temperature, respiratory rate, and systolic and diastolic blood pressure may be utilized as factors, indicators, or other conditions utilized to

determine the status of the user. As previously noted, the status or condition of the user may have been previously known or newly determined.

[0070] Next, the wireless earpieces determine whether sensor measurement thresholds are exceeded (step 408). The sensor measurement thresholds may also correspond to a specific user status as determined during step 407 and whether that user status is exceeded or not. The wireless earpieces may include any number of thresholds, including, high and low thresholds for measurements and parameters, such as pigment levels or chemical levels. Other sensor thresholds, such as forces experienced by the user, acceleration, temperature, pulse rate, blood oxygenation, blood pressure, user's stated status (e.g., hot, cold, clammy, nauseous, sweaty, faint, etc.) may also be utilized. For example, the wireless earpieces may have a profile that sets two or more thresholds for each biometric reading. In one embodiment, two or more of the thresholds may be violated in order to send communications as specified in step 410 (e.g., ketones, temperature, blood pressure, etc.).

[0071] In response to determining the sensor measurement thresholds are exceeded in step 308, the wireless earpieces send communications regarding the user's condition (step 310). In one embodiment, the communications are sent to the communications device linked with the wireless earpieces. The sensor measurements and user's condition may be sent to any number of user's, devices, applications, platforms, or so forth. For example, the communications may be an alert, status update, warning, or other similar information. In one embodiment, the communication may be an alert indicating that the user may be experiencing a diabetic event. Likewise, the communication may indicate that the user's ketone levels, temperature, and blood pressure has exceeded one or more thresholds (whether high or low) and may be experiencing an alcoholic relapse. The information from the wireless earpieces may be particularly valuable for users with known medical conditions, such as individuals with diabetes, liver disease, cancer, or so forth. The communications device may be monitored by medical professionals, coaches, parents, administrators, caregivers, or any number of other monitoring groups or individuals to ensure the safety of the user.

[0072] In response to determining the sensor measurement thresholds are not exceeded in step 408, the wireless earpieces utilize additional sensors and analysis as needed (step 412). In one embodiment, the additional sensors may be worn or integrated with the user.

[0073] For example, additional measurements may be taken by a smart watch, or chest strap worn by the user. In another example, a pacemaker of the user may provide additional data regarding pulse, heart rhythm, and other applicable or measured information. During step 412, the software utilized by the wireless earpieces or associated wireless devices and control/baseline data utilized to compare the sensor measurements may perform or execute additional analysis, algorithms, processes, or sets of instructions. In one embodiment, additional sensor measurements may be required to definitively determine the status of the user. In one embodiment, the wireless earpieces may indicate if the status of the user is unknown, undefined, or requires additional analysis during step 408.

[0074] FIG. 5 is a flowchart of a process for monitoring a user utilizing wireless earpieces in accordance with an illustrative embodiment. The process of FIG. 5 is similar to

that of FIG. 4 and may be performed as part of the process of FIG. 4 or as an independent method or set of steps. The steps of FIG. 4 and FIG. 5 may be integrated or combined in any number of combinations.

[0075] The process of FIG. 5 may begin by measuring deviations of sensor measurements over time (step 502). Sensor measurements may be performed constantly, at intervals, or as otherwise specified by the wireless earpieces, the user, or an administrator or other controlling party. As previously noted, the biometric readings taken by the sensors may include ketone levels, pigmentation readings, heart rate, respiratory rate, pulse oximetry, body temperature, systolic and diastolic blood pressure, orientation (e.g., standing, laying down, sitting, etc.), user wakefulness (e.g., sleeping, dreaming, awake, drowsy, etc.), stages of sleep (stages 1, 2, 3, 4, rapid eye movement (REM)), user motion, blood chemical levels, calories burned, sweat levels, and so forth. These sensors may monitor biometrics as well as environmental changes in deviations. For example, the wireless earpieces may note when the user's ketone levels have increased significantly. The wireless earpieces may track multiple biometric and environmental variables over time to best determine the user's condition, activities, mindset, and status.

[0076] Next, the wireless earpieces identify trends (step 504). The trend may indicate a general direction, movement, change, or progression of the data measured by the sensors. The trends may be particularly useful for tracking metabolic disorders. In one embodiment, the wireless earpieces may indicate the blood sugar levels of the user to indicate status and generate warnings or alerts. As previously noted, the sensor data may be analyzed by the wireless earpieces alone, by a linked computing or communications device, or utilizing the wireless earpieces and a combination of other devices, systems, equipment, components, or so forth.

[0077] Next, the wireless earpieces compare the sensor measurements to control data (step 506). The control data may correspond to user specific information including baseline readings, default data, or so forth. In one example, the control data may correspond to programmed or baseline data set by the user, such as user biometrics when the user has a normal level of ketones. The control data may also correspond to any number of activities that the user may perform, such as walking, running, swimming, playing sports, sleeping, resting, studying, or any number of activities to ensure that the measurements and user status are accurately determined. For example, there may be natural variations in sensor biometrics based on the activity being performed by the user. The wireless earpieces may also include control data that is determined or aggregated from any number of users. The most appropriate data set may be selected from the control data corresponding to the user's age, sex, ethnicity, weight, or other measured or user entered parameters, factors, and conditions.

[0078] Next, the wireless earpieces determine whether a trigger event is detected (step 508). The trigger event may represent any number of thresholds, factors, levels, baseline/comparative readings, or parameters. In one embodiment, the thresholds utilized for the trigger event may include one or more upper or lower threshold levels or values. The determination of step 508 may be made based on the measurements, analysis, and processing performed by the wireless earpieces. In one example, the trigger event may be associated with blood pressure and ketone levels of a user.

In another example, the trigger event may be associated with heart rate of the user and blood sugar levels. An event may be triggered in response to 1) the heart rate of the user being above 140 beats per minute (bpm) or below 55 bpm, and/or 2) the blood sugar level of the user exceeding 180. Any combination, group, or sets of one or more, or two or more, or numerous thresholds variables may be set for the thresholds utilized during step 508. In one embodiment, the thresholds may be specified by the user or another party associated with the user based on the user's individual characteristics. In one embodiment, if both the heart rate and blood sugar thresholds are exceeded, the wireless earpieces may trigger a response. In another example, the temperature and blood pressure of the user may also be utilized as factors to determine whether the trigger event is detected.

[0079] If the trigger event is reached during step 508, the wireless earpieces communicate a warning to specified parties (step 510). In some embodiments, the warning may represent a health risk to the user. In one example, if biometric readings show a rise in ketones, associated with a concurrent rise in heart rate and respiratory rate, while demonstrating a progressive drop in systolic and diastolic blood pressure, the wireless earpieces may trigger an alert to the user indicating that such patterns are typically associated with a negative metabolic event. As a result, the user may be able to take a break, drink water, visit with a medical professional, or so forth with a similar recommendation communicated to the user as part of step 510. Any number of devices, users, applications, or other entities may represent the specified parties.

[0080] Each of the separate thresholds may be associated with distinct event, alerts or warnings, or indicators presented to the user or specified parties (step 512). As previously noted, the warning may be communicated audibly, tactilely, or electrically (e.g., electrical pulses) through the wireless earpieces. Similarly, the warning may be communicated to any number of other users, systems, administrators, caregivers, medical professionals, or electronic devices directly or through one or more network connections. In one example, the warning may be queued for communication in response to the wireless earpieces being within range of a specified wireless device, interface, network component, or so forth. Even though each threshold, parameter, or value by itself may not be sufficient to trigger the event during step 508, when the thresholds are analyzed together over time, such data may be used to trigger the event so that the user and other specified parties may be warned of potential issues. In some embodiments, the threshold may not be exceeded or passed for the trigger event is reached. For example, if analysis of the sensor measurements and trends show a rate of change for biometric readings that is unacceptable, the trigger event may be reached before the biometric readings even reached the thresholds to best protect the user. The thresholds may also represent rates of change and if those rates of change are exceeded, the trigger event may be detected.

[0081] Next, the wireless earpieces communicate applicable information including the trigger data and changes in the sensor measurements (step 512). The applicable information may include the user status (if known), applicable biometric readings, environmental readings corresponding to the user, as well as suggested actions or activities to address the triggered alert. The trigger data and the changes in the sensor measurements are also communicated to the

user to give additional background information, details, data, information, and context for why the event was triggered. In one embodiment, the steps 510 and 512 may be combined into a single step. During steps 510, 512 powerful data analytics are transmitted to the user in an easily understood fashion (e.g., audio alerts, tactile alerts, alerts communicated to an app of a wireless device associated with the wireless earpieces, etc.).

[0082] If the trigger event is not reached during step 508, the wireless earpieces refine the control data and update user specific information (step 514). The control data may be updated only as needed to provide the best results and processing of the sensor measurements. During step 514, the wireless earpieces may periodically, intermittently, or as selected by the user update user specific information, such as thresholds utilized to set the trigger events. In one embodiment, the software or algorithms utilized to perform analysis, identification, comparisons, or so forth may be tuned or updated during step 514. Updates may be performed automatically or in response to information and changes from external sources, such as databases, users, systems, or so forth. In some embodiments, no updates, refining, or processing may be performed during step 514. For example, user specific conditions, such as the environment, may be utilized to tune the analysis performed. In hotter environments, the thresholds for the temperature of the user may be increased or decreased accordingly. FIG. 6 is a pictorial representation of a graphical user interface 600 in accordance with an illustrative embodiment. The graphical user interface 600 may be presented by a wireless device 602, such as the wireless device 106 of FIG. 1. In one embodiment, the graphical user interface 600 may present information measured and communicated to the wireless device 602 by the wireless earpieces. The graphical user interface 600 may interact with a user utilizing multivariate parameters, conditions, measurements, and so forth. In one embodiment, the graphical user interface 600 is a display portion of an application utilized to track, communicate, and display user biometrics.

[0083] The information presented by the graphical user interface 600 may also be communicated audibly through the wireless earpieces. In addition, any number of communications methods including projection, tactile feedback, and so forth may be used to communicate content captured by the wireless earpieces.

[0084] In one embodiment, the graphical user interface 600 may display information, data, and instructions for addressing a user condition determined by user biometrics. For example, the graphical user interface 600 may indicate that the blood sugar levels of the user are high. The graphical user interface 600 may also provide user or condition specific instructions for addressing the user's condition as determined.

[0085] In another embodiment, the wireless earpieces may capture information indicating that the user is drinking excessively. Excessive drinking may lead to dangerous conditions, such as alcohol poisoning, drunk driving, passing out, poor decision making, or any number of associated physical or emotional problems. The graphical user interface 600 may provide feedback to the user. The graphical user interface 600 may provide instructions or feedback to the user. For example, the graphical user interface 602 may present a physical or environmental warning. The graphical user interface 600 may also present the biometric readings to

the user, such as blood alcohol level, temperature, heart rate, respiration rate, and so forth. The graphical user interface 600 may indicate the user's current biometric readings as well as the threshold that was exceeded to trigger the event, such as the graphical user interface 600 and associated content being displayed to the user or played by the wireless earpieces. The wireless earpieces may also provide feedback to a parent or guardian for an underage user.

[0086] The graphical user interface 600 may be utilized to present information as well as receive content from the user. For example, the graphical user interface 600 may receive content from the user including thresholds utilized to generate alerts, authentication settings, alert settings, and so forth. For example, the graphical user interface 600 may indicate that the user should not be driving and may even communicate with one or more vehicle systems to prevent the user from driving.

[0087] The illustrative embodiments provide a system, method, personal area network, and wireless earpieces for communicating sensor measurements and an associated user status to a user and one or more externally connected devices. The sensor measurements may be utilized to send communications, updates, alerts, or other information relative to the condition of the user as well as the user's environment. In one embodiment, the sensor measurements may be utilized to protect the user based on one or more sensor measurements that are made, such as potential for disorders, diseases, sicknesses, trauma, or other user conditions. Sensor measurements from other sensors may be utilized to analyze, confirm, or verify the sensor measurements and user condition.

[0088] The illustrative embodiments may take the form of an entirely hardware embodiment, an entirely software embodiment (including firmware, resident software, micro-code, etc.) or an embodiment combining software and hardware aspects that may all generally be referred to herein as a "circuit," "module" or "system." Furthermore, embodiments of the inventive subject matter may take the form of a computer program product embodied in any tangible medium of expression having computer usable program code embodied in the medium. The described embodiments may be provided as a computer program product, or software, that may include a machine-readable medium having stored thereon instructions, which may be used to program a computing system (or other electronic device(s)) to perform a process according to embodiments, whether presently described or not, since every conceivable variation is not enumerated herein. A machine readable medium includes any mechanism for storing or transmitting information in a form (e.g., software, processing application) readable by a machine (e.g., a computer). The machine-readable medium may include, but is not limited to, magnetic storage medium (e.g., floppy diskette); optical storage medium (e.g., CD-ROM); magneto-optical storage medium; read only memory (ROM); random access memory (RAM); erasable programmable memory (e.g., EPROM and EEPROM); flash memory; or other types of medium suitable for storing electronic instructions. In addition, embodiments may be embodied in an electrical, optical, acoustical or other form of propagated signal (e.g., carrier waves, infrared signals, digital signals, etc.), or wireline, wireless, or other communications medium.

[0089] Computer program code for carrying out operations of the embodiments may be written in any combination

of one or more programming languages, including an object oriented programming language such as Java, Smalltalk, C++ or the like and conventional procedural programming languages, such as the “C” programming language or similar programming languages. The program code may execute entirely on a user’s computer, partly on the user’s computer, as a stand-alone software package, partly on the user’s computer and partly on a remote computer or entirely on the remote computer or server. In the latter scenario, the remote computer may be connected to the user’s computer through any type of network, including a local area network (LAN), a personal area network

[0090] (PAN), or a wide area network (WAN), or the connection may be made to an external computer (e.g., through the Internet using an Internet Service Provider).

[0091] FIG. 7 depicts a computing system 700 in accordance with an illustrative embodiment. For example, the computing system 700 may represent a device, such as the wireless device 204 of FIG. 2. The computing system 700 includes a processor unit 701 (possibly including multiple processors, multiple cores, multiple nodes, and/or implementing multi-threading, etc.). The computing system includes memory 707. The memory 707 may be system memory (e.g., one or more of cache, SRAM, DRAM, zero capacitor RAM, Twin Transistor RAM, eDRAM, EDO RAM, DDR RAM, EEPROM, NRAM, RRAM, SONOS, PRAM, etc.) or any one or more of the above already described possible realizations of machine-readable media. The computing system also includes a bus 703 (e.g., PCI, ISA, PCI-Express, HyperTransport®, InfiniBand®, NuBus, etc.), a network interface 706 (e.g., an ATM interface, an Ethernet interface, a Frame Relay interface, SONET interface, wireless interface, etc.), and a storage device(s) 709 (e.g., optical storage, magnetic storage, etc.). The system memory 707 embodies functionality to implement embodiments described above. The system memory 707 may include one or more functionalities that facilitate retrieval of the audio information associated with an identifier. Code may be implemented in any of the other devices of the computing system 700. Any one of these functionalities may be partially (or entirely) implemented in hardware and/or on the processing unit 701. For example, the functionality may be implemented with an application specific integrated circuit, in logic implemented in the processing unit 701, in a co-processor on a peripheral device or card, etc. Further, realizations may include fewer or additional components not illustrated in FIG. 7 (e.g., video cards, audio cards, additional network interfaces, peripheral devices, etc.). The processor unit 701, the storage device(s) 709, and the network interface 705 are coupled to the bus 703. Although illustrated as being coupled to the bus 703, the memory 707 may be coupled to the processor unit 701.

[0092] The features, steps, and components of the illustrative embodiments may be combined in any number of ways and are not limited specifically to those described. In particular, the illustrative embodiments contemplate numerous variations in the smart devices and communications described. The foregoing description has been presented for purposes of illustration and description. It is not intended to be an exhaustive list or limit any of the disclosure to the precise forms disclosed. It is contemplated that other alternatives or exemplary aspects are considered included in the disclosure. The description is merely examples of embodiments, processes or methods of the invention. It is under-

stood that any other modifications, substitutions, and/or additions may be made, which are within the intended spirit and scope of the disclosure. For the foregoing, it can be seen that the disclosure accomplishes at least all of the intended objectives.

[0093] The previous detailed description is of a small number of embodiments for implementing the invention and is not intended to be limiting in scope. The following claims set forth a number of the embodiments of the invention disclosed with greater particularity.

What is claimed is:

1. A method for determining a status of a user utilizing wireless earpieces, comprising:

performing sensor measurements of a user utilizing at least optical sensors of the wireless earpieces, wherein the optical sensors detect metabolic abnormalities of the user;

analyzing the sensor measurements;

determining the status of the user utilizing at least sensor measurements from the optical sensors of the wireless earpieces; and

communicating an alert to the user in response to there being a change in the status of the user.

2. The method of claim 1, further comprising:

linking the wireless earpiece with a communications device, wherein the wireless earpieces are linked with the communications device utilizing a Bluetooth connection, and wherein the alert is displayed by the communications device as received from the wireless earpieces.

3. The method of claim 1, wherein the analyzing comprises:

measuring deviations of the sensor measurements over time, identifying trends associated with the sensor measurements, and comparing the sensor measurements to control data for the user.

4. The method of claim 1, wherein the sensor measurements further include biometric readings of the user including at least ketone levels, pigmentation changes, pulse, voice or audio output, blood pressure, temperature, and user experienced forces.

5. The method of claim 1, wherein the sensor measurements indicate whether the user is in distress.

6. The method of claim 1, wherein the optical sensors include at least one blue light emitting diode (LED).

7. The method of claim 1, further comprising:

communicating the alert to one or more users associated with the user.

8. The method of claim 1, wherein the alert includes at least the sensor measurements and the user status.

9. The method of claim 1, wherein the alert includes two or more thresholds exceeded by the sensor measurements.

10. The method of claim 1, wherein the sensor measurements are performed utilizing a predetermined schedule.

11. The method of claim 1, wherein the wireless earpiece communicates the alert to the user at least audibly and indicates the user status.

12. A wireless earpiece, comprising:

a frame for fitting in an ear of a user;

a logic engine controlling functionality of the wireless earpiece;

a plurality of sensors measuring biometric readings of the user, wherein the plurality of sensors include at least optical sensors and are configured to detect metabolic abnormalities of the user;

a transceiver communicating with at least a wireless device;

wherein the logic engine analyzes the biometric readings, determines the status of the user utilizing at least biometric readings from the optical sensors of the wireless earpieces, and communicate an alert to the user in response to there being a change in the status of the user.

13. The wireless earpiece of claim **12**, wherein the transceiver establishes a Bluetooth link with the wireless device, wherein the alert is communicated to the wireless device for display to the user utilizing a graphical user interface, and wherein the alert is displayed by the communications device as received from the wireless earpieces.

14. The wireless earpiece of claim **12**, wherein the logic engine analyzes the biometric readings by measuring deviations of the sensor measurements over time, identifying

trends associated with the sensor measurements, and comparing the sensor measurements to control data for the user.

15. The wireless earpiece of claim **12**, wherein the biometric readings include biometric readings of the user including at least ketone levels, pigmentation changes, pulse, voice or audio output, blood pressure, temperature, and user experienced forces.

16. The wireless earpiece of claim **12**, wherein the alert indicates whether the user is in distress.

17. The wireless earpiece of claim **16**, further comprising: a memory in communication with the logic engine, wherein the memory stores a plurality of thresholds, wherein each of the plurality of thresholds for the biometric readings includes a high threshold and a low threshold.

18. The wireless earpiece of claim **12**, wherein the optical sensors include at least one blue light emitting diode (LED).

19. The wireless earpiece of claim **12**, wherein the alerts are communicated to one or more users, devices, or systems.

* * * * *

专利名称(译)	使用无线耳机检测代谢紊乱		
公开(公告)号	US20180008194A1	公开(公告)日	2018-01-11
申请号	US15/638011	申请日	2017-06-29
申请(专利权)人(译)	BRAGI GMBH		
当前申请(专利权)人(译)	BRAGI GMBH		
[标]发明人	BOESEN PETER VINCENT		
发明人	BOESEN, PETER VINCENT		
IPC分类号	A61B5/00 A61F5/00		
CPC分类号	A61B5/6803 A61F5/0013 A61B5/0015 A61B5/0095 A61B5/01 A61B5/021 A61B5/024 A61B5/08 A61B5/1455 A61B5/4866 G08B5/36 G08B21/0453 G08B25/10 H04R1/1016 H04R1/1091 H04R2420/07 G08B3/10		
优先权	62/358764 2016-07-06 US		
其他公开文献	US10045736		
外部链接	Espacenet USPTO		

摘要(译)

一种利用无线耳机确定用户状态的方法包括至少利用无线耳机的光学传感器对用户进行传感器测量，其中光学传感器检测用户的代谢异常，分析传感器测量值，确定传感器的状态。用户至少利用来自无线耳机的光学传感器的传感器测量结果，并响应于用户状态的变化向用户传送警报。还提供了一种无线耳机或一组带有用于检测代谢异常的光学传感器的无线耳机。

