



US 20170027466A1

(19) **United States**

(12) **Patent Application Publication**  
**Kerth et al.**

(10) **Pub. No.: US 2017/0027466 A1**

(43) **Pub. Date: Feb. 2, 2017**

(54) **HEADGEAR FOR DRY  
ELECTROENCEPHALOGRAPH SENSORS**

**Publication Classification**

(71) Applicants: **Trevor Austin Kerth**, London (GB);  
**Yu Mike Chi**, San Diego, CA (US);  
**Aileen Ngoc Tran**, San Diego, CA  
(US)

(51) **Int. Cl.**  
*A61B 5/0478* (2006.01)  
*A61B 5/00* (2006.01)  
(52) **U.S. Cl.**  
CPC ..... *A61B 5/0478* (2013.01); *A61B 5/6814*  
(2013.01); *A61B 2562/04* (2013.01)

(72) Inventors: **Trevor Austin Kerth**, London (GB);  
**Yu Mike Chi**, San Diego, CA (US);  
**Aileen Ngoc Tran**, San Diego, CA  
(US)

(57) **ABSTRACT**

(21) Appl. No.: **15/300,992**

A headgear for placing sensors on a subject's head includes a centerpiece; a plurality of arms attached to and radiating generally downward from the centerpiece; and sensor tips attached to the dorsal ends of at least some of the arms. At least one of the plurality of arms is a lower arm that is elastic and/or spring-like. When the headgear is placed on a subject's head, the at least one lower arm is so disposed in relation to the maximum circumference of the subject's head that the at least one lower arm must be bent outward for placement of the headgear on the subject's head and thereby provide a reactive force toward the head that causes the at least one lower arm to grasp at least a portion of the head that is at and/or below the maximum circumference of the head.

(22) PCT Filed: **Apr. 1, 2015**

(86) PCT No.: **PCT/US15/23851**

§ 371 (c)(1),  
(2) Date: **Sep. 30, 2016**

**Related U.S. Application Data**

(60) Provisional application No. 61/973,618, filed on Apr. 1, 2014, provisional application No. 62/079,124, filed on Nov. 13, 2014.

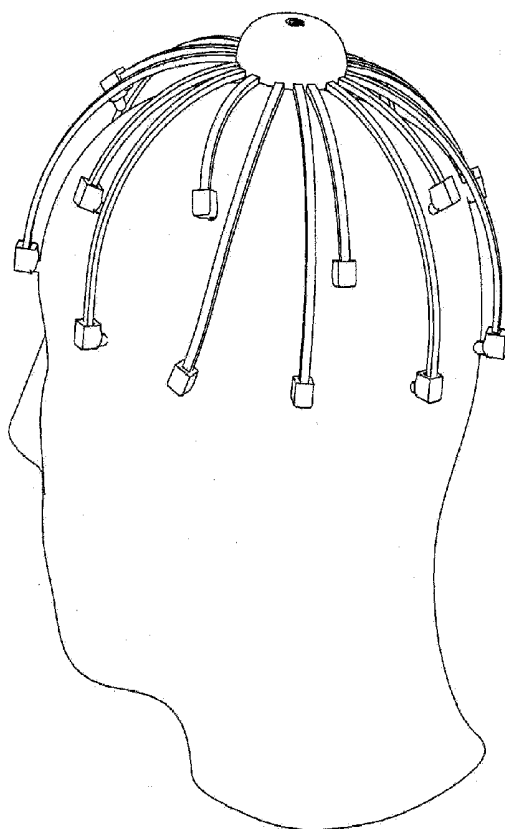

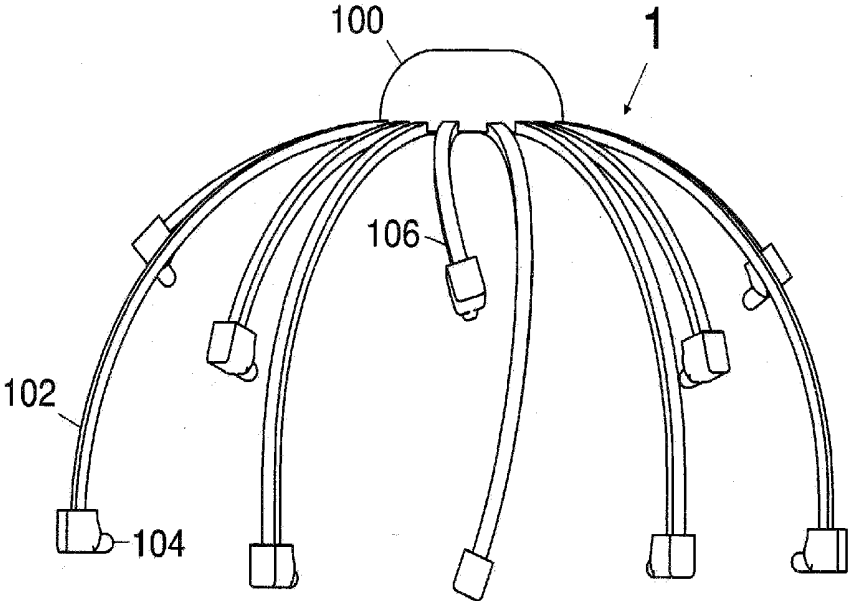

FIG. 1

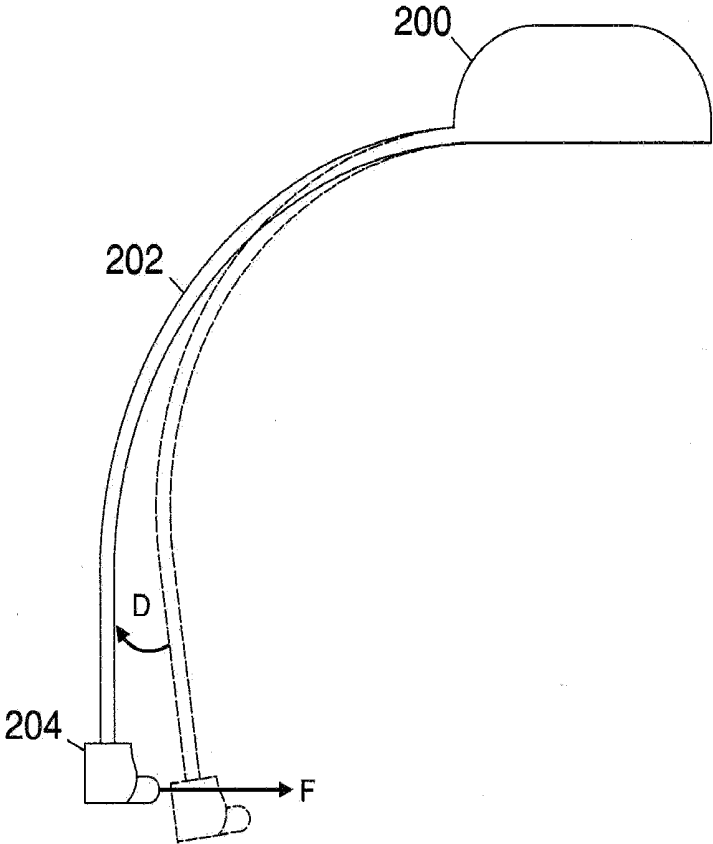

FIG. 2

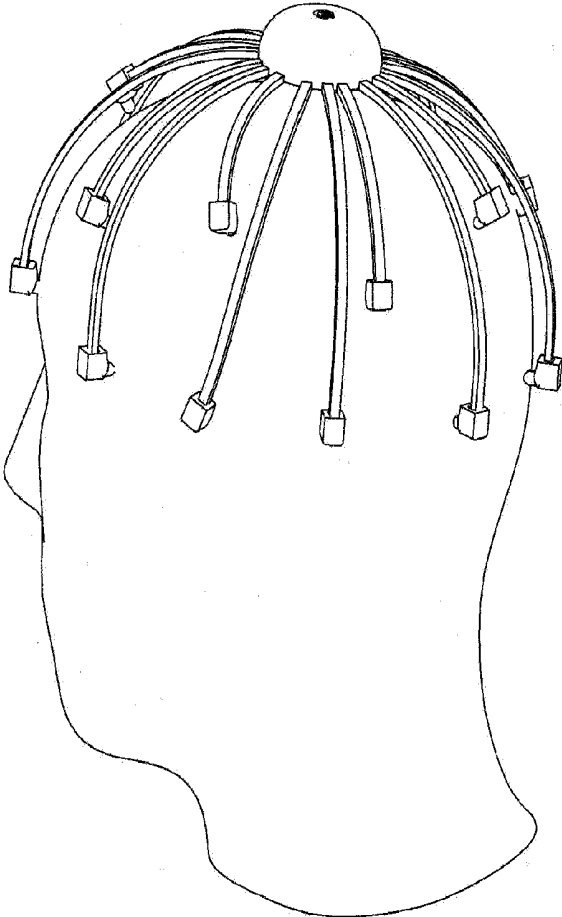

FIG. 3

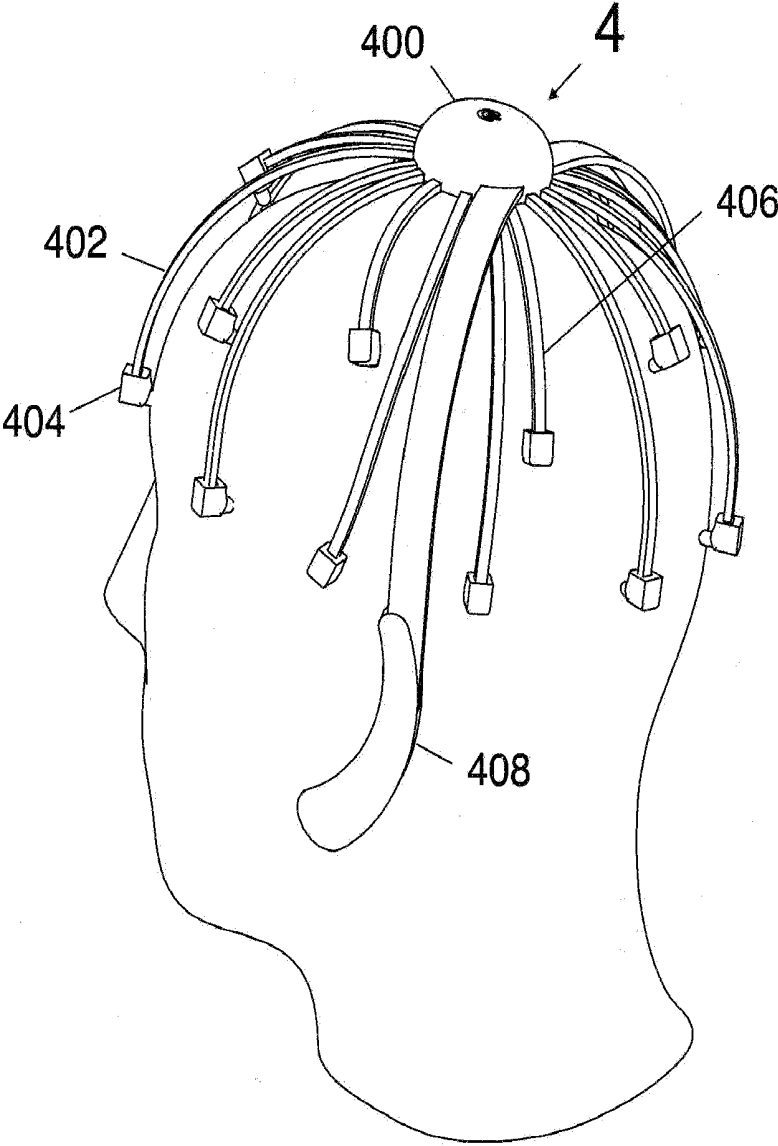

FIG. 4

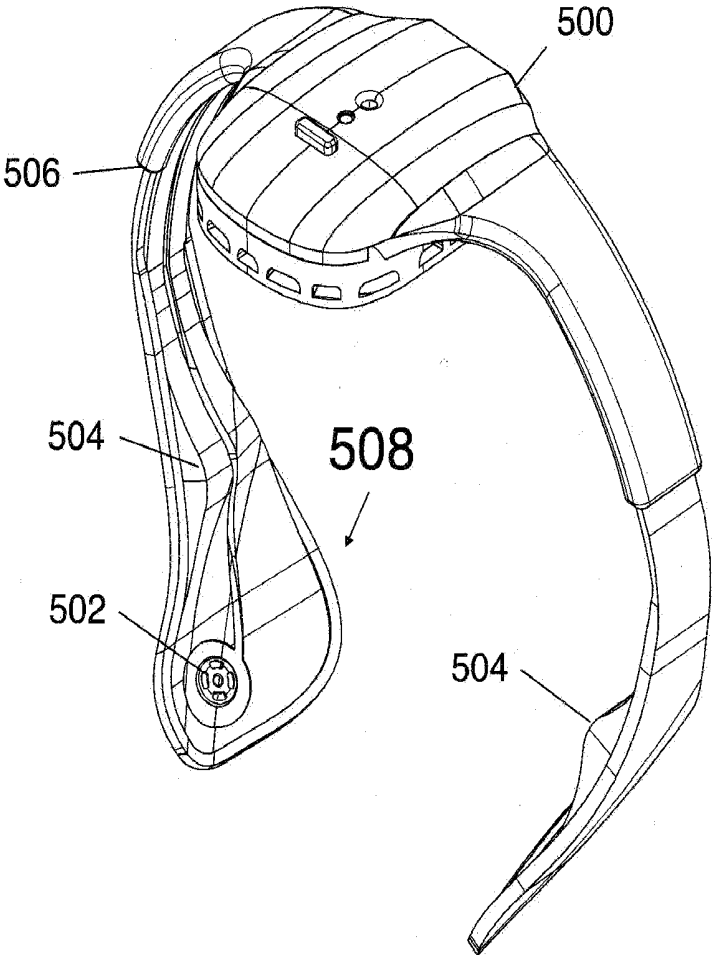

FIG. 5

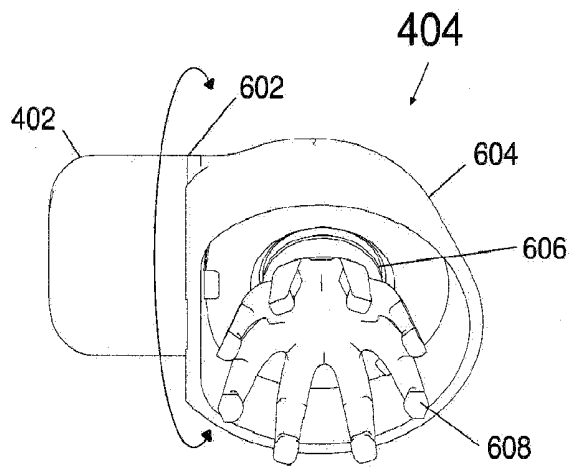

FIG. 6

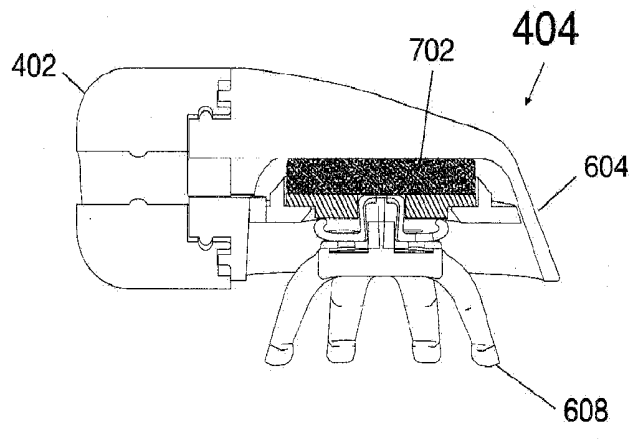

FIG. 7

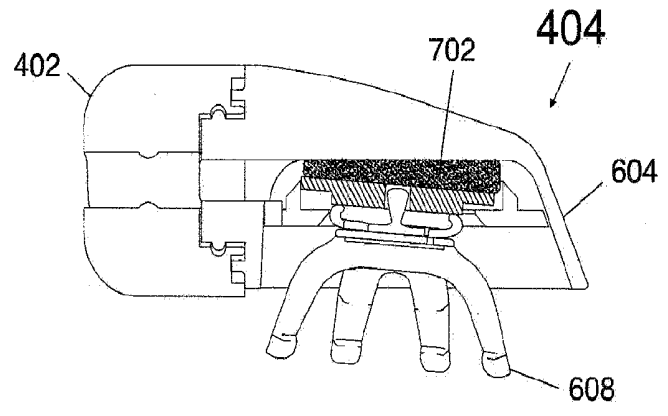

FIG. 8

## HEADGEAR FOR DRY ELECTROENCEPHALOGRAM SENSORS

### BACKGROUND OF THE INVENTION

**[0001]** The invention relates to headgears and mounting apparatuses, specifically devices that enable the rapid and reliable placement of sensors on a subject's head. The focus of this patent is for dry electrode EEG applications, although the invention is broadly applicable to placing any type sensor or transducer on the head of a subject.

**[0002]** Conventional recording of EEG signals predominantly involves the use of wet electrodes that utilize a gel for conduction to the subject's scalp. The wet electrodes can be affixed to the skin either with glue or placed in an elastic cap. In many cases, abrasion of the scalp is necessary. The high conductivity of the gel allows electrical conductivity to permeate through hair and any physical gaps between the surface of the electrode and the surface of the scalp is filled and buffed by the gel's liquidity. As a result, wet electrodes offer a secure, low-impedance electrical connection between the subject and the recording instruments with minimal need for advanced mechanics.

**[0003]** However, the use of electrolytic gels, adhesives and scalp abrasion is often time consuming, irritating and uncomfortable for the subject. In response, dry electrodes, which do not require conductive gels, adhesives, or scalp preparation, have been explored as an alternative. In practice, dry electrodes suffer from numerous usability issues. Although acquiring signals on bare skin (e.g., forehead) is straightforward, most EEG setups also require electrodes to be placed across the entire head and especially over areas with hair. With no gel buffer, dry electrodes depend on mechanically stable and adjustable sensor mounts to secure the sensor on the surface of the subject's head.

**[0004]** Challenges with dry EEG headgears involve the need to conform to the many variations in human head shape and size with a standard design that can be used by all subjects. For a dry EEG headgear to be useful, it must also be simple to apply and remove. The basic approach to constructing a dry EEG headgear is based upon adapting the standard elastic EEG cap, exemplified by Gevins et. al. in U.S. Pat. No. 4,967,038. The elasticity in the cap enables it to stretch and cover different sized heads. However, elastic caps suffer from a numerous problems. Although elastic caps are generally flexible, the generic 'balloon-like' shape does not fully conform well to the exact contours of different head shapes (e.g., 'boxy' heads or dimples), leading to areas where the cap is overly tight and other areas where the cap is loose. In addition, the closed nature of the cap makes adjusting the electrodes difficult in cases where the electrodes are in the wrong position or poorly contacting the scalp. Finally, because the elastic cap has no rigid supports, individual electrodes inside the cap are prone to tipping and misalignment during application.

**[0005]** As a result, more sophisticated designs have been explored that use mechanical headgears with mechanisms to individually place sensors on the head for better performance and reliability. One example is found in U.S. Pat. No. 8,103,328 by Turner et al. where each sensor is mounted on a spring-loaded assembly at the tip of an arm connected to a hinge. The hinging mechanism in the arm helps orient the sensor to the surface of the head and the arm generates pressure that connects the sensor to the head. This system is effective at providing optimized and individual tension for

each of the sensors in the array but the overall design is complex and bulky. Each headgear contains multiple joints, springs and other moving parts making the system heavy and expensive.

**[0006]** For a simpler and less expensive design, Trewartha et al. (WO 2008/109699 A2) shows a headgear that contains only a few moving parts. In this design, most of the hinges and springs are replaced with solid arms. Only two pivots are present for rotating two major groups of sensors. Plastic deformation of the arms generates tension without the need for other mechanics of moving parts. However, the design shown by Trewartha imposes severe geometric constraints, especially for EEG applications which involve placement of the sensors at specific locations around the scalp. The headgear includes a left band and a right band that clamp on to the head near a user's temples. While this is effective in securing the headgear to the user, the arrangement biases the locations of the electrodes to the sides of the head—areas that are particularly prone to muscular artifacts. Placement of sensors on the upper half of the head and the back of the head, which is necessary for many research and medical EEG applications, cannot be readily accommodated with this setup.

### SUMMARY OF THE INVENTION

**[0007]** The invention provides a headgear for placing sensors on a subject's head, comprising: a centerpiece; a plurality of arms attached to and radiating generally downward from the centerpiece; and sensor tips attached to the dorsal ends of at least some of the arms; wherein at least one of the plurality of arms is a lower arm that is elastic and/or spring-like; and wherein while the headgear is being placed on the subject's head, the at least one lower arm must reach, by bending outwards, to or beyond the maximum circumference of the subject's head, thereby providing a reactive force for holding the headgear on the subject's head after the headgear has been placed on the subject's head.

**[0008]** By itself, the headgear forms a diameter that is nominally smaller than the maximum circumference of a subject's head so that when the headgear is placed on the subject's head, at least one of the lower arms is forced to bend outward in order to grasp the scalp and thereby apply the reactive force to generate grasping pressure between the at least one lower arm and the scalp.

**[0009]** In view of the limitations with prior art dry EEG headgear, the headgear of the invention involves a minimum of moving parts and adjustments. In some embodiments, upper arms of shorter lengths also radiate outward from the centerpiece to place more sensors on the upper half of the subject's head and thereby make it possible to approximate a standard EEG 10-20 sensor layout. Because each arm moves independently, the headgear is able to fully conform to different head sizes and geometries. The lack of moving parts and adjustments means that a user can easily and quickly slide the headgear on with minimal assistance and time.

**[0010]** Further aspects of the invention are described in the following detailed description.

### BRIEF DESCRIPTION OF THE DRAWING

**[0011]** FIG. 1 is a side perspective view on an exemplary embodiment of a headgear according to invention, which shows the major components of the headgear.

[0012] FIG. 2 illustrates the bending of a single lower arm of the headgear shown in FIG. 1

[0013] FIG. 3 is an illustration the exemplary embodiment of the headgear shown in FIG. 1, as placed on a subject's head.

[0014] FIG. 4 is an illustration of another exemplary embodiment of the a headgear according to invention, including lower arms that grip behind the ears and sensor tips that provide extra conformance to the subject's head.

[0015] FIG. 5 is an illustration of still another exemplary embodiment of a headgear according to the invention, including ear bands that grip behind the ears. The other lower and upper arms are omitted for purposes of clarity.

[0016] FIG. 6 is an illustration of a sensor tip assembly in the embodiment of FIG. 4 showing the ability to rotate the sensor tip.

[0017] FIG. 7 is an illustration of a sensor tip assembly in the embodiment of FIG. 4 showing the ability to compress and tilt the sensor tip.

[0018] FIG. 8 shows the sensor tip assembly of FIG. 7, with the cushion being compressed to thereby allow the sensor tip to tilt.

#### DETAILED DESCRIPTION

[0019] Referring to FIG. 1, an exemplary embodiment of a headgear 1 according to the invention includes a centerpiece 100, lower arms 102, sensor tips 104 and an upper arms 106. A preferred embodiment of the headgear 1 contains at least two lower arms 102 and optionally one or more upper arms 106. However, for purposes of clarity, the descriptions below will refer to each generically rather than as specific individual units since embodiments may have multiple, similar copies of each.

[0020] The centerpiece 100 provides a reference position for the entire headgear 1. In the exemplary embodiment shown in FIG. 1, the centerpiece 100 is a dome with sufficient interior volume to house the electronics for the headgear 1. The centerpiece is an ideal location for placing electronic components for sensing neurological signals, such as amplifiers, microprocessors, wireless transceivers and control buttons since it is equidistant from all peripheral sensor points and facilitates easy access by the user.

[0021] In other embodiments, the centerpiece 100 may be much simpler. In its most basic form, the centerpiece 100 provides a reference position from which a lower arm 102 radiates. In the embodiments shown herein, all the lower arms 102 and upper arms 106 meet at a single centerpiece 100 because it facilitates placement of approximately the 10-20 EEG electrode array. In other embodiments, different groups of lower arms 102 and/or upper arms 106 may radiate from multiple reference positions provided by multiple centerpieces 100 to provide different sensor layouts optimized for measuring signals at specific areas of the scalp.

[0022] The lower arms 102 radiate out and down from the centerpiece 100. The overall diameter formed by all of the sensor tips 104 attached to the lower arms 102 is dimensioned to be smaller than the subject's head. Therefore, when the headgear is placed onto the subject's head, the lower arms 102 are forced to bend and deflect outward in order to accommodate the shape of the head. The action of deflecting the lower arms 102 that hold the sensor tips 104 on the head generates a reactive force that grasps the sensor tips 104 securely to the subject's head.

[0023] In some cases, as will be described in greater detail below, the sensor tips 104 may be replaced with alternative structures for grasping the subject's head.

[0024] Two important properties of the lower arms 102 are noted. First, the headgear depends on the clamping action of at least one of the lower arms 102 to grasp the subject's head. In the shown exemplary embodiment, the headgear 1 uses an array of similar lower arms 102 for stability. Other possible configurations may include more or less lower arms 102, depending on specific requirements. It is even possible to construct an embodiment that contains only one lower arm 102. In such a case, a rigid, non-springy, support grasps the opposing side of the head. Second, the lower arms 102 must be long enough to reach at least the maximum circumference of the head where there is no upward sloping contour of the head.

[0025] More specifically, the lower arm 102 must terminate at a point that enables it to securely hold the headgear 1 onto the user's head. From a geometric standpoint, this point can more precisely be defined by first considering the head as an ovoid, then forming a tangential plane to the ovoid centered at the centerpiece 100. A lower arm 102 extending from the centerpiece 100 also projects a line onto this tangential plane. A second line can then be drawn, from the first line and radiating out from the plane, towards the closest tangent point on the surface of the ovoid.

[0026] For the lower arm 102 to adequately grasp the head, it must extend to, or beyond, the critical point where second line becomes perpendicular to the first line and plane. This is the point after which the head starts to "curve away" from the center of the headgear. There is one such critical point for each direction that a lower arm 102 may extend from the centerpiece 100.

[0027] Under both of these constraints, the summation of the forces generated by each of the lower arms 102 against the head will be evenly balanced and not generate any upward force on the headgear. If the lower arms 102 are too short to reach the maximum circumference of the head, the interaction between the sensor tips 104 and the sloped surface of the head would generate an upward force whereby the headgear would exhibit a tendency to travel up and off the head.

[0028] FIG. 2 shows a detail of the deflection process in the lower arm 202. The initial state of the lower arm 202 is illustrated in the dotted lines. Bending the lower arm 202 outwards in the direction D causes a reactive force F due to the elastic and/or spring-like deformation of the lower arm 202. When the headgear is placed on a subject's head, the reactive the force F causes the sensor tips 204 to grasp the scalp sufficiently to form a connection that enables sensing or transduction.

[0029] In the exemplary embodiment of the invention, the sensor tip 204 is formed as a cylindrical knob, coated with an Ag/AgCl material to serve as a dry EEG electrode. Broadly speaking, the invention is not limited to any specific electrode or contact design. Another embodiment of the invention may use a set of pins or other dry electrode design. Alternatively the sensor tips 204 need not be dry or even an EEG electrode. As an example, a wet EEG headgear may be constructed by placing saline soaked foam at the sensor tips 204. It is also possible to build a fNIRS (functional near-infrared spectroscopy) headgear by mounting optical transducers and detectors on the sensor tips 204. Finally, alter-

native embodiments of the invention may mix and match different types of sensors and transducers in accordance with the application and position.

[0030] In the exemplary embodiment shown in FIG. 2, the sensor tip 204 is a single continuous piece of material that is integral with the lower arms 202. In other embodiments, it may be preferable to connect the sensor tips 204 to the lower arms 202 with a joint (not shown) that is capable of pivoting, rotating or moving to better align the sensor tips 204 with the local geometry of the user's head. Additionally, the joint may be spring-loaded for more conformability. In alternative embodiments an attachment mechanism is included to enable the sensor tips 204 to be removed from the lower arms 202.

[0031] FIG. 3 shows an exemplary embodiment of the headgear when placed on a human head. The array of lower arms and upper arms radiating from a centerpiece approximates the standard 10-20 EEG electrode placements. Other embodiments of the invention can accommodate different types of sensor placements in accordance with the particular sensing application.

[0032] Referring again to FIG. 1, the upper arms 106 are used to more broadly place sensors on the head, not just at the circumferential locations enabled by the lower arms 102. The upper arms 106 likewise terminate in sensor tips 104 but are shorter to cover additional scalp locations above the maximum circumference. The difference, however, is that the upper arms 106 cause the sensor tips that are attached thereto to contact a sloped area of the head, which in turn generates an upward reactive force on the headgear as a whole. Since the upper arms 106 do not provide a direct counteracting force, such as provided by the lower arms 102, the upward reactive force generated by contacting the upward sloped area of the head can act to push the headgear 1 up and away from the head. Therefore, embodiments that utilize upper arms 106 must be so designed that the lower arms 102 generate sufficient clamping force to counteract the upward force generated by placement of the upper arms 106 on the upward sloped area of the head.

[0033] In some embodiments, extra arms (not shown) are included for generating additional frictional force to help counteract the upward reactive force generated by placement of the upper arms 106 on the upward sloped area of the head. One example involves placing extra lower arms 102 that have large pads, instead of sensor tips attached to the dorsal ends, in order to generate a frictional force.

[0034] In other embodiments of the invention, only the upper arms 106 include sensor tips 104 and the lower arms 102 are used only for grasping the subject's head. In general, it is possible to mix and match different combinations of tips: sensors and grasping pads to suit a particular application. It is also possible to mix and match different sensors in the same headgear. For example, an application may call for placing optical SpO<sub>2</sub> sensors on the forehead arms and EEG sensors at the remaining locations.

[0035] Referring to FIG. 4, another exemplary embodiment utilizes an ear grip 408 that contacts the areas of the head adjacent to the subject's ears for extra stability. Using the area around the ears is particularly advantageous since it presents a large, relatively flat, surface area for distributing contact pressure. A headphone-like, circumaural cup is an example of an ear grip and may be used in some embodiments of the invention. However a full headphone-type ear cup presents several drawbacks. An ear cup limits hearing

and may also interfere with certain sensor positions near the temples, such as T3 or T4 (in the international 10-20 convention). Embodiments of the invention may preferentially use a partial ear cup that does not fully surround and/or cover the ears to overcome the above limitations.

[0036] The ear grip 408 shown in the embodiment of FIG. 4 also illustrates a second key retaining mechanism for holding the device on to the subject's head. Whereas the lower arms 102 (shown in the embodiment of FIG. 1), operate primarily on the basis of a frictional grasping force by holding onto scalp locations along or below the maximum circumference of the head, the ear grip also employs a hooking action (in addition to some degree of frictional force) by resting around and under the lower surfaces of the head that are beyond the maximum circumference.

[0037] Referring to FIG. 5, an ear band 508 is used as a variant of the ear grip 408. In this case, the ear band 508 is based on the same basic concept of the ear grip 408, but only spans the surfaces around the posterior of the ear, near the mastoid. The area behind the ear and mastoid is useful since it contains few muscles and joints, and thereby minimizes movement of the headgear. This location also allows the lower half of the ear band 508 to rest on the underside of the subject's head and use a hooking action for keeping the system from moving up and off the user.

[0038] A detailed diagram of a specific ear band 508 embodiment is shown in FIG. 5, without any of the other lower or upper arm types for purposes of clarity. The structure can be considered another type of lower arm but additionally optimized for holding the headset on to the head rather than for only holding a sensor. Like most types of lower arms, the ear band 508 emanates from the centerpiece 500 and contains a sensor 502 mounted for measuring signals from the subject's mastoid. In contrast to the lower arms previously described, however, the primary purpose of the ear band 508 is to provide stability and hence contains extra surface area around the sensor 502 for distributing contact pressure across a large portion of the head. In this embodiment, the ear band 508 also contains a sliding joint 506 to enable the user to adjust the length for optimal placement on the head. A contour 504 is also used to better match the surface of the ear band 508 to the surface of the head.

[0039] It is also worth noting that other embodiments of the invention may also utilize other variants of lower arm shapes to grasp or hook onto other areas of the head for stabilizing the headgear. In general, any surface of the head or body below the maximum circumference of the head is suitable, such as the chin. Using extra sets of lower arms, which are primarily optimized for grasping or hooking, is advantageous in many cases since it allows the other lower arms, which are used for sensing, to contact the subject's head with minimal pressure for ensuring comfort.

[0040] FIG. 6 shows a more sophisticated embodiment of the sensor tip 404 used in the embodiment of FIG. 4. The embodiment shown in FIG. 6 adds extra degrees of freedom for complex electrodes. Whereas the sensor tip 104 used in embodiment of FIG. 1 is a simple structure that functions directly as the sensing electrode, the sensor tip 404 contains multiple parts to optimally place an electrode 608 that is separate from the main body referred to collectively as the sensor tip 404.

[0041] In this embodiment, the sensor tip 404 is connected to the lower arm 402 via a rotating joint 602. This allows the

electrode **608**, which is connected via the receptacle **606**, to better align with the surface of the subject's head by providing an extra degree of freedom. In addition, the sensor tip **404** contains a conductive shield **604** that covers, and extends around the sides of the electrode **608** to provide extra electromagnetic shielding against external interference. Optimally, the shield **604** will surround the electrode in all directions that are not facing the subject for maximum protection.

**[0042]** A cutaway view of the sensor tip **404** of the embodiment of FIG. **4** is shown in FIG. **7**. To provide for extra conformance to the subject, the electrode **608** is mounted on a cushion **702**. This provides yet another extra degree of freedom by allowing the electrode **608** to tilt and align with the irregular surfaces of the scalp. FIG. **8** shows an example of how compressing cushion **702** tilts the electrode **608**. In the embodiment, the cushion **702** is made from foam. Other materials and designs are possible including using a spring or suspending the electrode **608** on a membrane. The cushion **702** has the additional benefit of mitigating some movement artifacts by dampening vibrational forces from the headset.

**[0043]** In the exemplary embodiment shown, the headgear **1** is made primarily out of ABS plastic. Manufacturing the headgear **1** out of a single piece of plastic greatly simplifies the production process and lowers cost although it is possible to also make the headgear from separate pieces joined together. Other embodiments may include other materials that capable of elastic deformation such as metal spring wires. It may also be advantageous to mix and match materials to provide a mix of mechanical properties. As an example, the upper arms may be made out of a more flexible material (e.g., nylon) than the lower arms (e.g., ABS or metal) to reduce the amount of undesired upward reactive force. In some cases, the headgear is made to be nominally conductive by using metal or a specially treated plastic in order to provide an electromagnetic shield for reducing interference noise.

**[0044]** The benefits specifically stated herein do not necessarily apply to every conceivable embodiment of the present invention. Further, such stated benefits of the present invention are only examples and should not be construed as the only benefits of the present invention.

**[0045]** While the above description contains many specificities, these specificities are not to be construed as limitations on the scope of the present invention, but rather as examples of the preferred embodiments described herein. Other variations are possible and the scope of the present invention should be determined not by the embodiments described herein but rather by the claims and their legal equivalents.

1. A headgear for placing sensors on a subject's head comprising:  
 a centerpiece;  
 a plurality of arms attached to and radiating generally downward from the centerpiece; and  
 sensor tips attached to the dorsal ends of at least some of the arms;  
 wherein at least one of the plurality of arms is a lower arm that is elastic and/or spring-like; and

wherein while the headgear is being placed on the subject's head, the at least one lower arm must reach, by bending outwards, to or beyond the maximum circumference of the subject's head, thereby providing a reactive force for holding the headgear on the subject's head after the headgear has been placed on the subject's head.

2. The headgear of claim **1**, wherein the sensor tips are connected to the dorsal ends of said at least some of the arms by a joint.

3. The headgear of claim **1**, wherein the headgear contains conductive material for shielding the sensor tips.

4. The headgear of claim **1**, wherein the centerpiece contains electronic components for sensing neurological signals.

5. The headgear of claim **1**, wherein at least some of the plurality of arms are upper arms disposed for placing sensor tips on the subject's head.

6. The headgear of claim **5**, wherein the plurality of arms are disposed for positioning the sensor tips at standard 10-20 EEG locations.

7. The headgear of claim **1**, further comprising:

at least one lower arm adapted for hooking below the maximum circumference of the subject's head for retaining said headgear on the subject.

8. The headgear of claim **7**, wherein said lower arm, which is adapted for hooking below the maximum circumference of the subject's head, is also adapted to supply the majority of the retaining force for said headgear thereby improving subject comfort.

9. The headgear of claim **8**, wherein said lower arm, which is adapted for hooking below the maximum circumference of the subject's head, is also adapted to be placed on the surfaces of the head adjacent to the subject's ears.

10. The headgear of claim **9**, wherein said lower arm, which is adapted for hooking below the maximum circumference of the subject's head, forms a circumaural cup around the subject's ears.

11. The headgear of claim **9**, wherein said lower arm, which is adapted for hooking below the maximum circumference of the subject's head, forms a band that contacts the mastoid area behind the subject's ears.

12. The headgear of claim **9**, wherein said lower arm, which is adapted for hooking below the maximum circumference of the subject's head, is also adapted to mount a sensor for transducing signals from the skin surface of the subject's mastoid.

13. The headgear of claim **1**, wherein the sensor tips are connected to the dorsal ends of said at least some of the arms by a rotating joint to thereby enable the orientation of said sensor tips to be aligned with the surface of the subject's head.

14. The headgear of claim **13** wherein an electrode is mounted on to said sensor tip by a cushion disposed for aligning the orientation of said electrode to the surface of the subject's head when the cushion is compressed.

15. The headgear of claim **14** wherein the housing of said sensor tip contains a conductive shield for guarding said electrode against external interference.

\* \* \* \* \*

专利名称(译)	干式脑电图传感器的头盔		
公开(公告)号	<a href="#">US20170027466A1</a>	公开(公告)日	2017-02-02
申请号	US15/300992	申请日	2015-04-01
[标]申请(专利权)人(译)	克尔斯特里沃奥斯丁 尺余MIKE TRAN AILEEN NGOC		
申请(专利权)人(译)	克尔思, TREVOR AUSTIN 迟, YU MIKE Tran, AILEEN NGOC		
当前申请(专利权)人(译)	克尔思, TREVOR AUSTIN 迟, YU MIKE Tran, AILEEN NGOC		
[标]发明人	KERTH TREVOR AUSTIN CHI YU MIKE TRAN AILEEN NGOC		
发明人	KERTH, TREVOR AUSTIN CHI, YU MIKE TRAN, AILEEN NGOC		
IPC分类号	A61B5/0478 A61B5/00		
CPC分类号	A61B5/0478 A61B2562/04 A61B5/6814 A61B2562/046		
优先权	61/973618 2014-04-01 US 62/079124 2014-11-13 US		
外部链接	<a href="#">Espacenet</a> <a href="#">USPTO</a>		

摘要(译)

用于将传感器放置在受试者头部上的头带包括中心件;多个臂连接到中心件并从中心件向下大致向下辐射;和传感器尖端连接到至少一些臂的背端。多个臂中的至少一个是下臂,其是弹性的和/或弹簧状的。当头带放置在受试者的头部上时,至少一个下臂相对于受试者头部的最大周长设置成使得至少一个下臂必须向外弯曲以将头带放置在受试者的头部上并且从而提供朝向头部的反作用力,该反作用力使至少一个下臂抓住位于头部的最大圆周处和/或之下的头部的至少一部分。

