



US 20160174894A1

(19) **United States**  
(12) **Patent Application Publication**  
**Proud**

(10) **Pub. No.: US 2016/0174894 A1**  
(43) **Pub. Date: Jun. 23, 2016**

(54) **MONITORING DEVICE FOR SNORING**

(71) Applicant: **Hello Inc.**, San Francisco, CA (US)

(72) Inventor: **James Proud**, San Francisco, CA (US)

(21) Appl. No.: **15/058,809**

(22) Filed: **Mar. 2, 2016**

part of application No. 13/960,491, filed on Aug. 6, 2013, Continuation-in-part of application No. 13/961,511, filed on Aug. 7, 2013, now Pat. No. 9,204,798, Continuation-in-part of application No. 13/961,599, filed on Aug. 7, 2013, now Pat. No. 9,149,189, Continuation-in-part of application No. 13/967,094, filed on Aug. 14, 2013, Continuation of application No. 13/967,109, filed on Aug. 14, 2013, Continuation of application No. 13/967,120, filed on Aug. 14, 2013,

**Related U.S. Application Data**

(Continued)

(63) Continuation of application No. 13/923,543, filed on Jun. 21, 2013, Continuation of application No. 13/923,560, filed on Jun. 21, 2013, now Pat. No. 8,803,366, Continuation of application No. 13/923,614, filed on Jun. 21, 2013, now Pat. No. 8,850,421, Continuation of application No. 13/923,637, filed on Jun. 21, 2013, now Pat. No. 8,810,430, Continuation of application No. 13/923,750, filed on Jun. 21, 2013, Continuation of application No. 13/923,809, filed on Jun. 21, 2013, Continuation of application No. 13/923,909, filed on Jun. 21, 2013, Continuation of application No. 13/923,937, filed on Jun. 21, 2013, Continuation-in-part of application No. 13/955,777, filed on Jul. 31, 2013, Continuation of application No. 13/955,810, filed on Jul. 31, 2013, now Pat. No. 9,320,434, Continuation of application No. 13/955,845, filed on Jul. 31, 2013, now Pat. No. 9,330,561, Continuation of application No. 13/955,892, filed on Jul. 31, 2013, Continuation-in-part of application No. 13/956,564, filed on Aug. 1, 2013, Continuation of application No. 13/956,674, filed on Aug. 1, 2013, Continuation of application No. 13/956,815, filed on Aug. 1, 2013, now Pat. No. 9,298,882, Continuation-in-part of application No. 13/959,022, filed on Aug. 5, 2013, Continuation-in-part of application No. 13/959,085, filed on Aug. 5, 2013, Continuation-in-part of application No. 13/960,075, filed on Aug. 6, 2013, Continuation-in-part of application No. 13/960,407, filed on Aug. 6, 2013, Continuation-in-part of application No. 13/960,436, filed on Aug. 6, 2013, Continuation-in-part of application No. 13/960,451, filed on Aug. 6, 2013, Continuation-in-

**Publication Classification**

(51) **Int. Cl.**  
*A61B 5/00* (2006.01)  
*A61B 7/00* (2006.01)  
*A61B 7/04* (2006.01)  
*A61B 5/113* (2006.01)  
*A61B 5/01* (2006.01)  
(52) **U.S. Cl.**  
CPC ..... *A61B 5/4818* (2013.01); *A61B 5/113* (2013.01); *A61B 5/01* (2013.01); *A61B 5/0059* (2013.01); *A61B 7/04* (2013.01); *A61B 5/0024* (2013.01); *A61B 7/003* (2013.01); *A61B 5/6889* (2013.01); *A61B 2505/07* (2013.01); *A61B 2562/029* (2013.01); *A61B 2560/0242* (2013.01)

(57) **ABSTRACT**

Systems and method are provided for monitoring a person's snoring in a dwelling. A detection device is in communication with a user monitoring device. The detection device includes at least one motion/movement gesture sensing device configured to detect at least one of a person's motion, movement and gesture. A user monitoring device includes at least one element selected from: a proximity sensor; a temperature sensor; a humidity sensor; a particulate sensor; a light sensor; a microphone; one or more RF transmitters (BLE/ANT+WIFI); a memory; and one or more LED's. The detection device and user monitoring device detect a person's level of snoring.

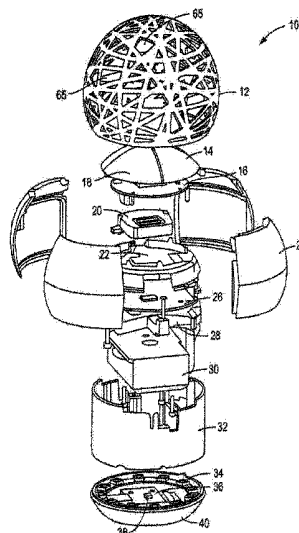

**Related U.S. Application Data**

Continuation of application No. 13/966,623, filed on Aug. 14, 2013, Continuation of application No. 13/966,641, filed on Aug. 14, 2013, Continuation-in-part of application No. 14/023,876, filed on Sep. 11, 2013, now Pat. No. 9,159,223, Continuation-in-part of application No. 14/036,111, filed on Sep. 25, 2013, Continuation of application No. 14/036,287, filed on Sep. 25, 2013, Continuation of application No. 14/036,382, filed on Sep. 25, 2013, Continuation-in-part of application No. 14/037,536, filed on Sep. 26, 2013, Continuation of application No. 14/037,594, filed on Sep. 26, 2013, Continuation of application No. 14/037,643, filed on Sep. 26, 2013, Continuation of application No. 14/037,717, filed on Sep. 26, 2013, now Pat. No. 9,055,791, Continuation of application No. 14/037,747, filed on Sep. 26, 2013, Continuation of application No. 14/037,825, filed on Sep. 26, 2013, now abandoned, Continuation of application No. 14/037,870, filed on Sep. 26, 2013, Continuation of application No. 14/037,974, filed on Sep. 26, 2013, now abandoned, Continuation-in-part of application No. 14/038,990, filed on Sep. 27, 2013, Continuation

of application No. 14/039,145, filed on Sep. 27, 2013, Continuation of application No. 14/039,802, filed on Sep. 27, 2013, Continuation-in-part of application No. 14/048,731, filed on Oct. 8, 2013, Continuation of application No. 14/049,690, filed on Oct. 9, 2013, Continuation of application No. 14/049,822, filed on Oct. 9, 2013, Continuation of application No. 14/051,093, filed on Oct. 10, 2013, Continuation of application No. 14/052,376, filed on Oct. 11, 2013, Continuation-in-part of application No. 14/180,109, filed on Feb. 13, 2014, Continuation-in-part of application No. 14/180,152, filed on Feb. 13, 2014, Continuation-in-part of application No. 14/495,332, filed on Sep. 24, 2014, now Pat. No. 9,320,435, Continuation of application No. 14/495,656, filed on Sep. 24, 2014, Continuation-in-part of application No. 14/588,848, filed on Jan. 2, 2015, Continuation of application No. 14/588,853, filed on Jan. 2, 2015, Continuation-in-part of application No. 14/604,566, filed on Jan. 23, 2015, Continuation of application No. 14/604,569, filed on Jan. 23, 2015, Continuation-in-part of application No. 14/725,973, filed on May 29, 2015, Continuation-in-part of application No. 14/729,608, filed on Jun. 3, 2015.

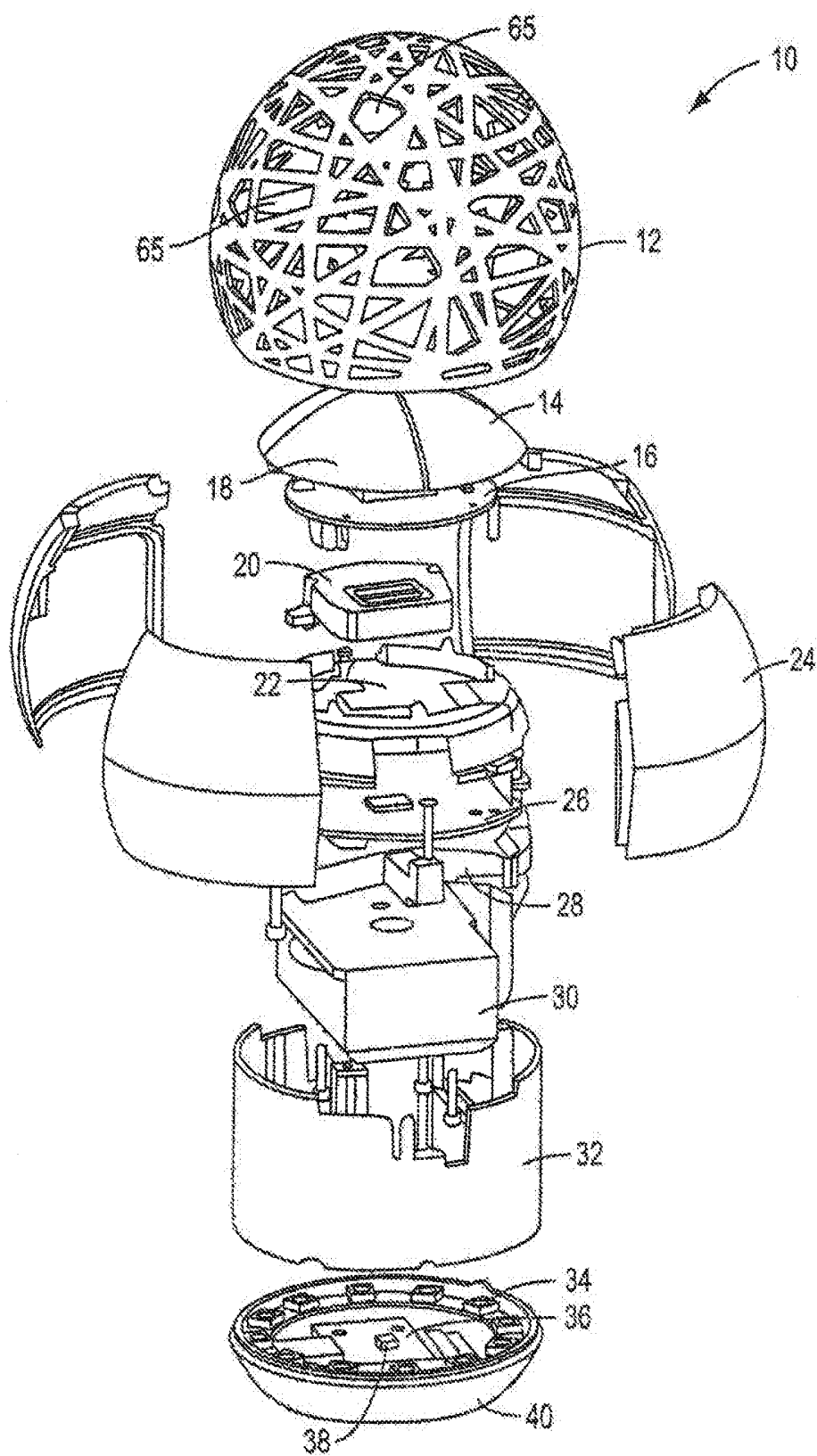

FIG. 1A

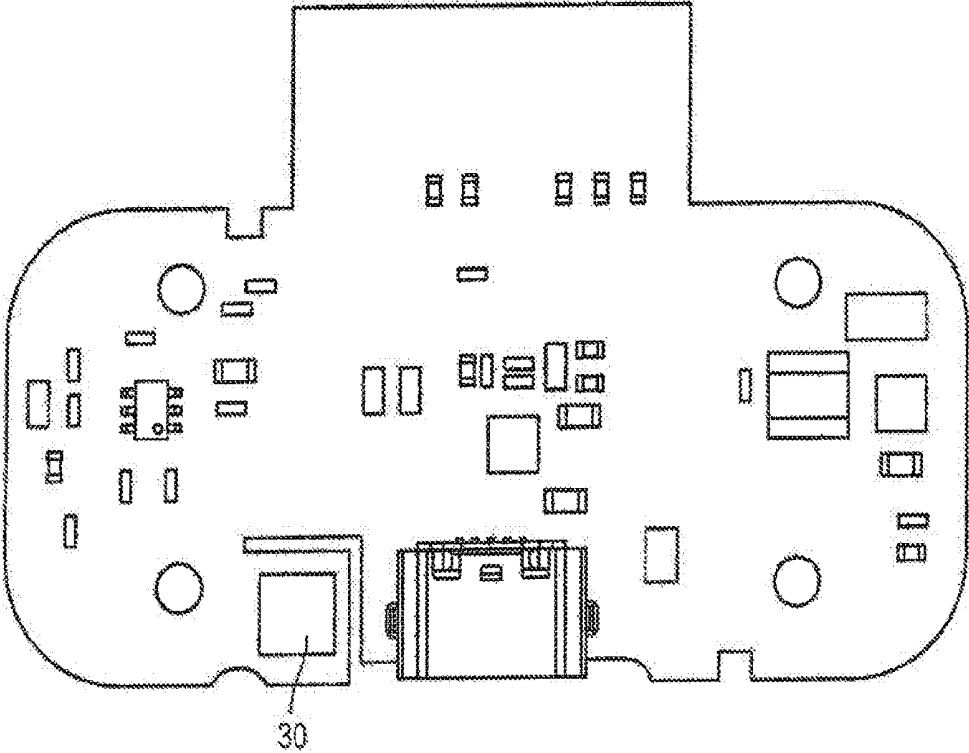

FIG. 1B

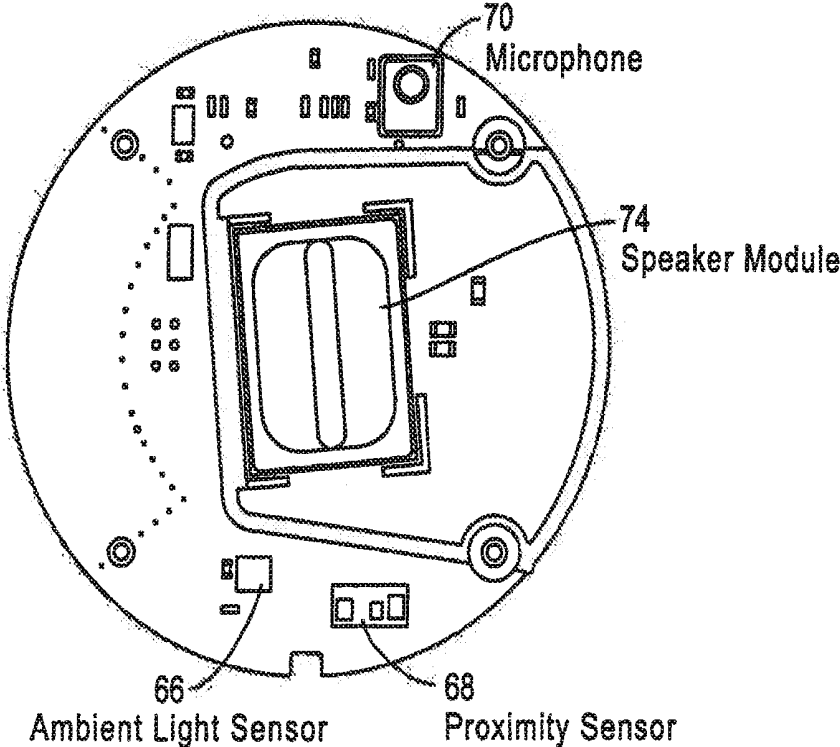

FIG. 1C

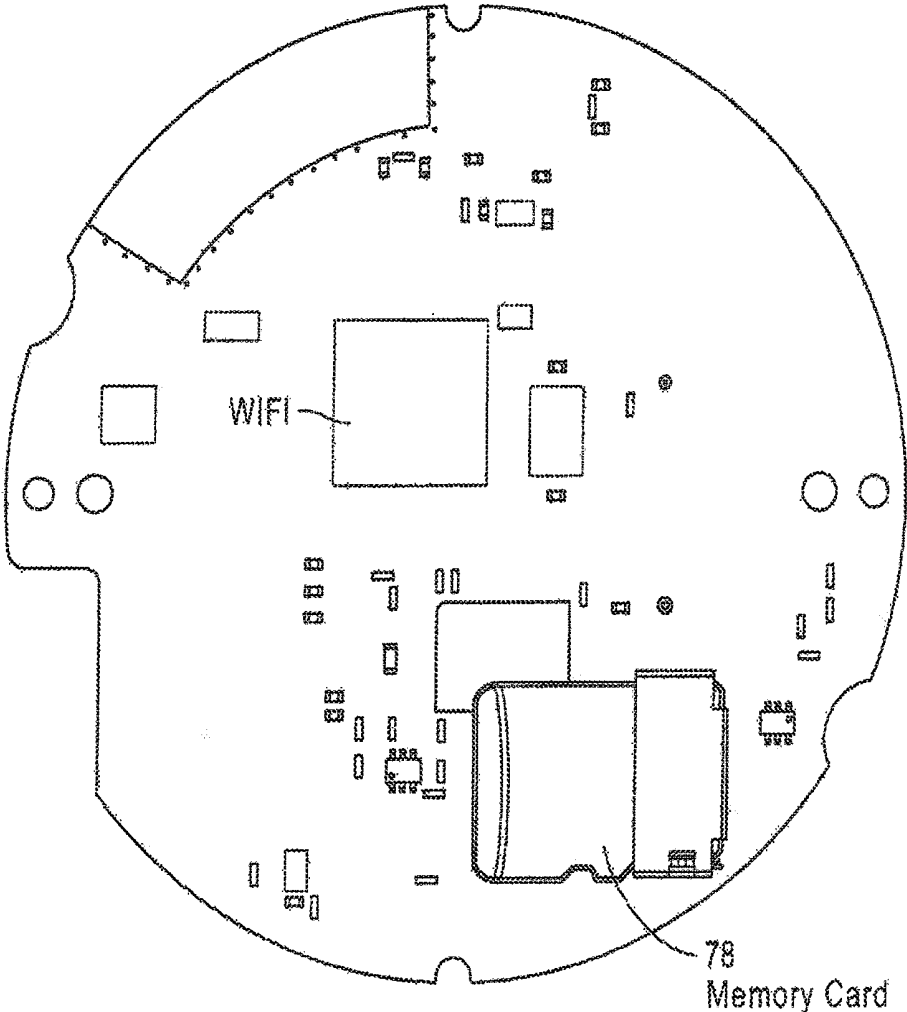

FIG. 1D

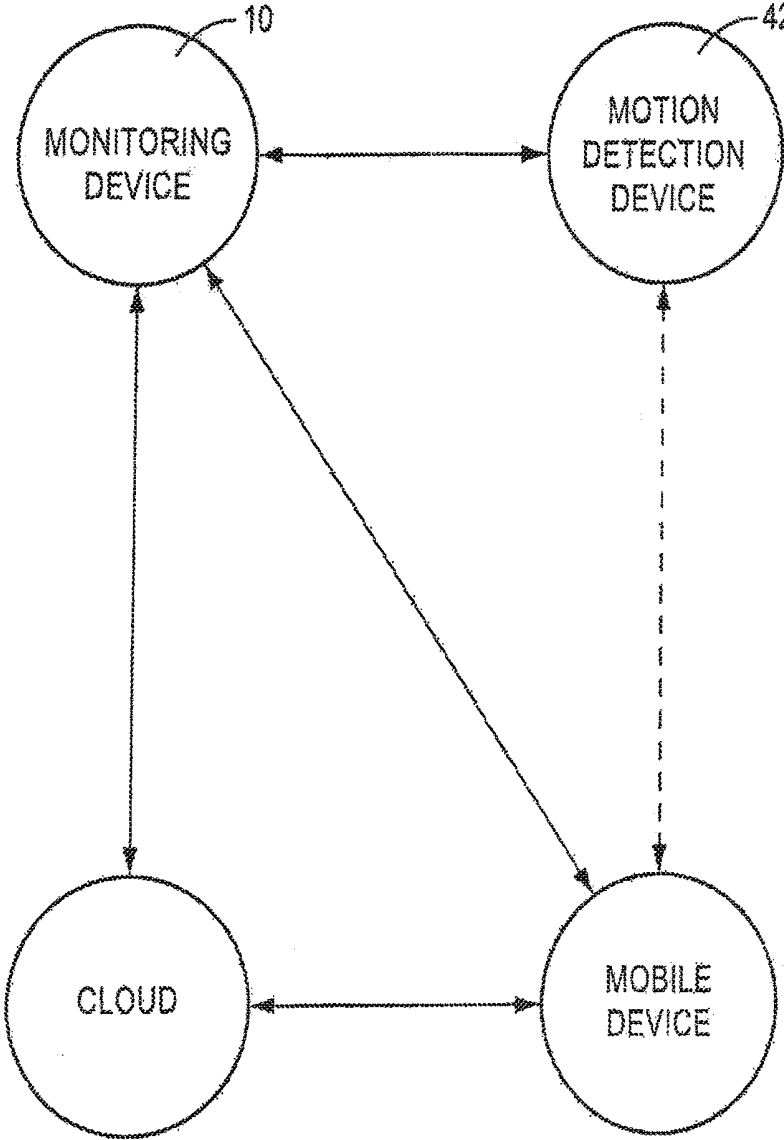
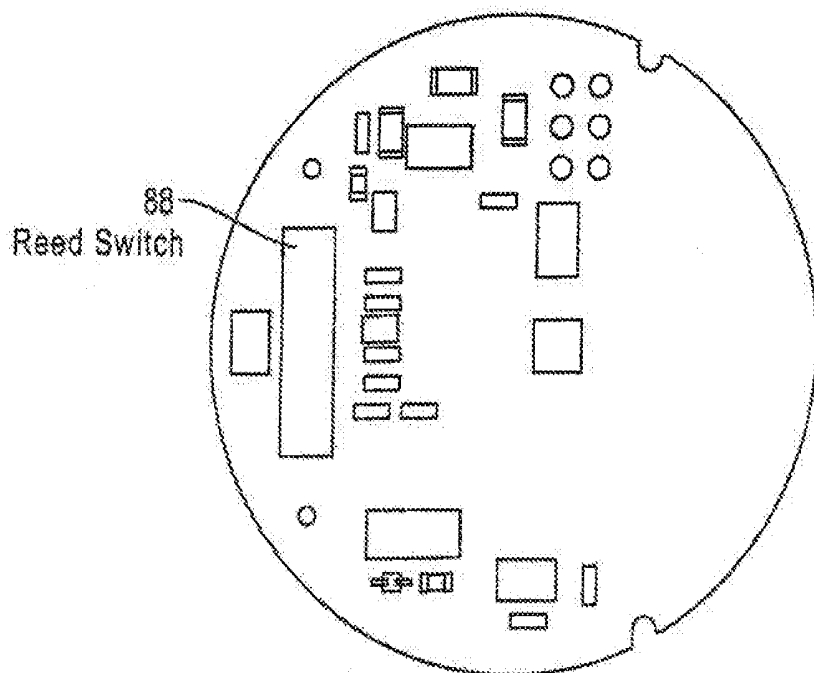
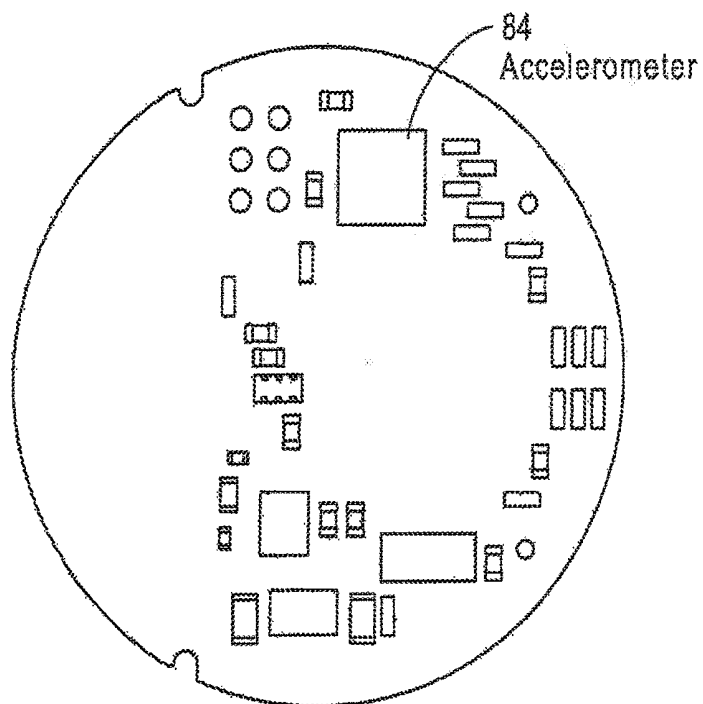

FIG. 1E





FRONT  
FIG. 2B



BACK  
FIG. 2C

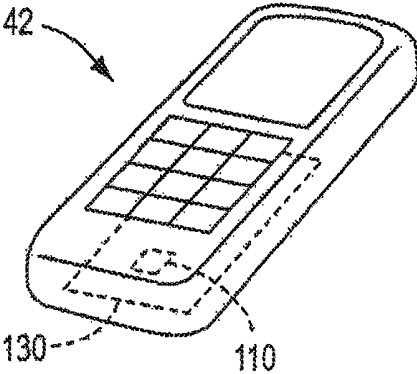

FIG. 3

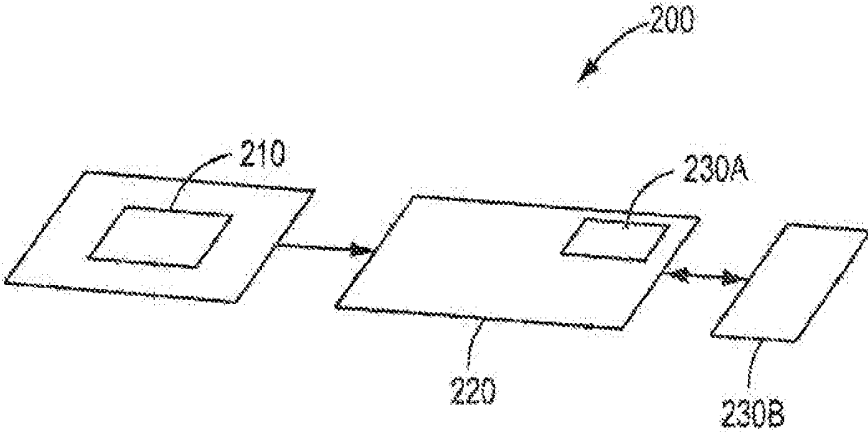

FIG. 4

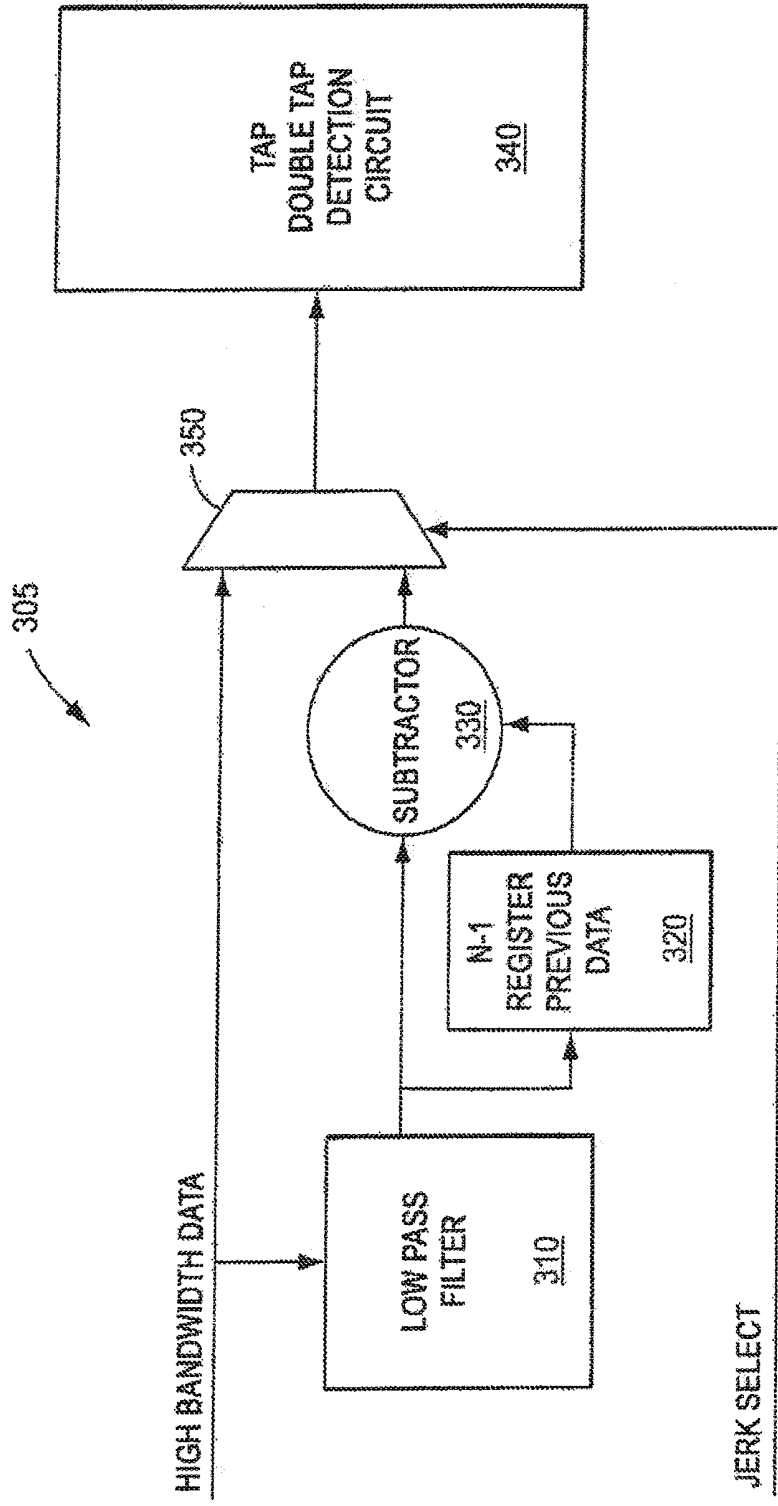

FIG. 5

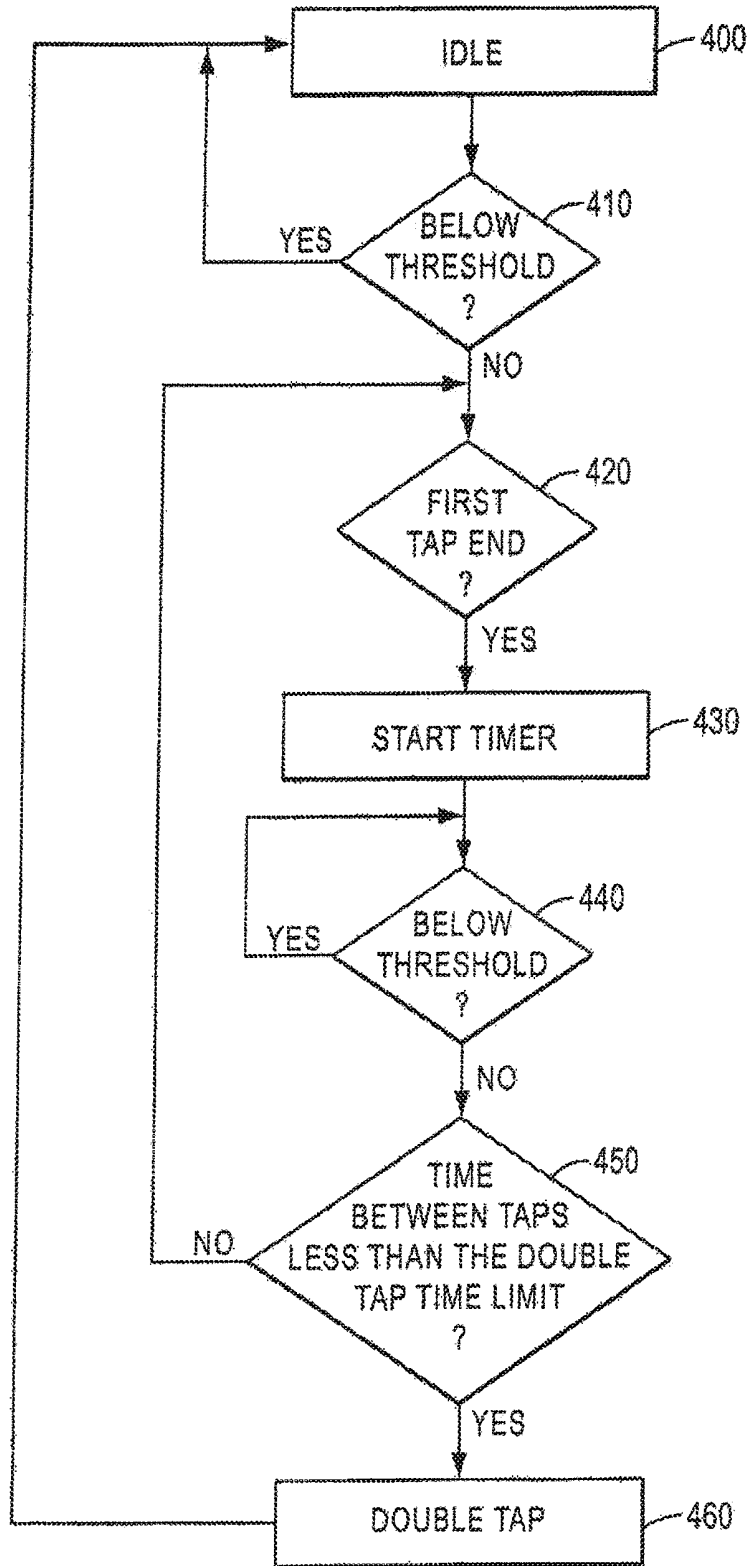

FIG. 6

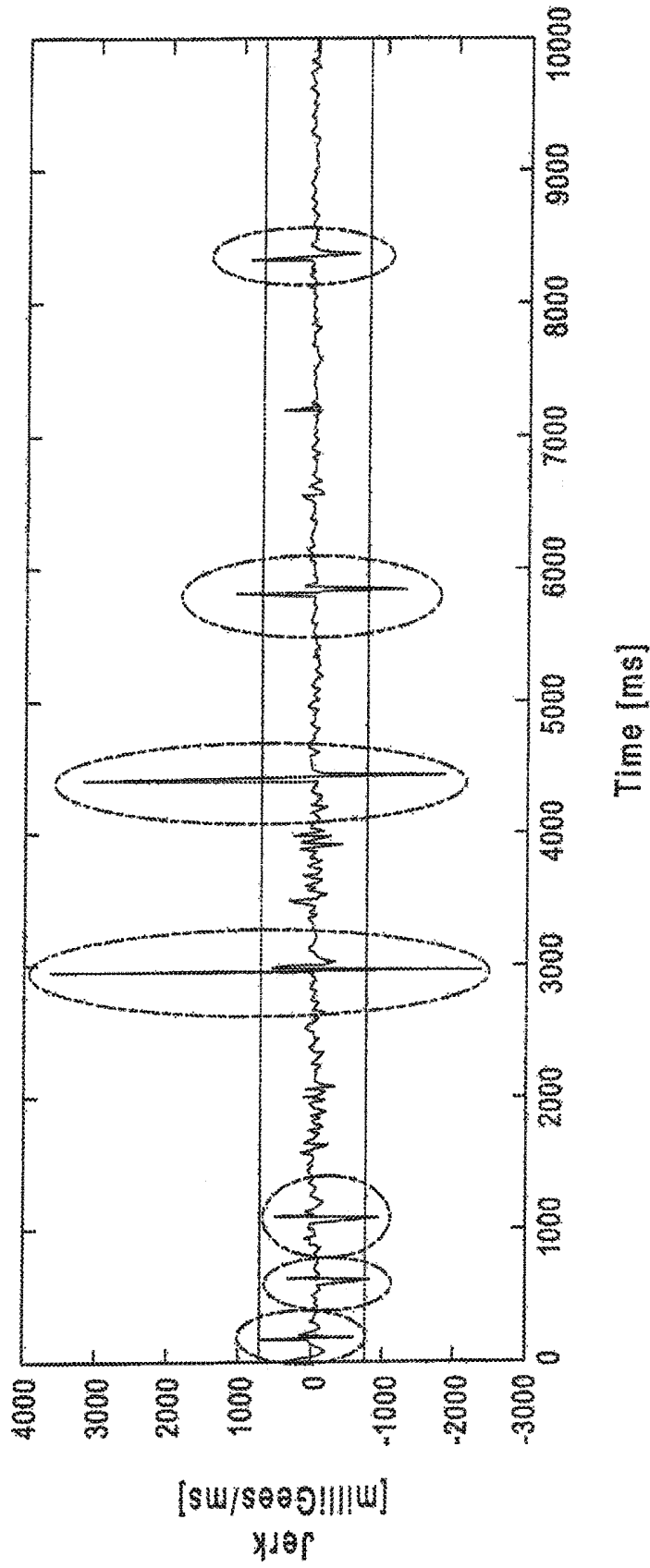

FIG. 7

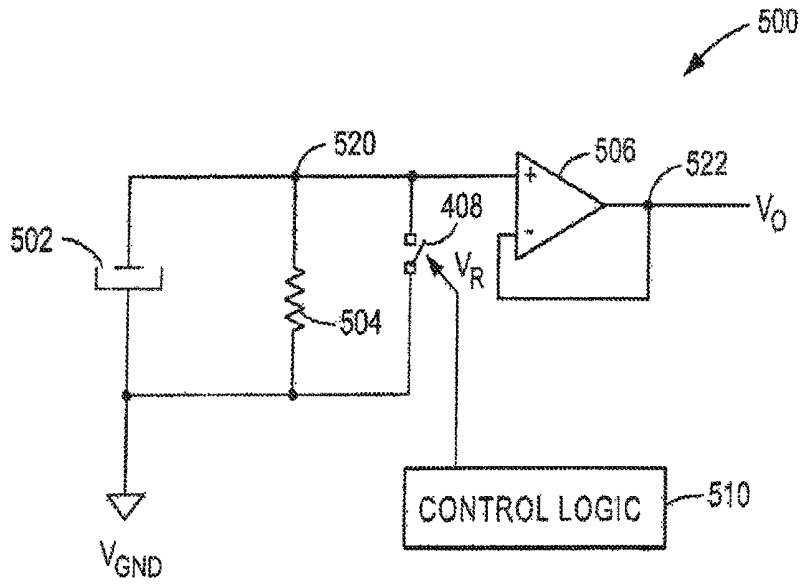

FIG. 8

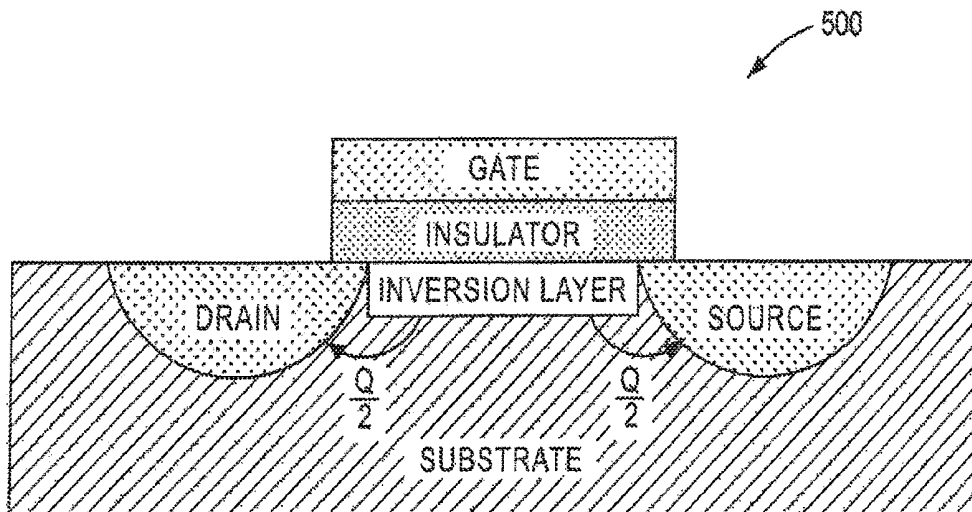

FIG. 9

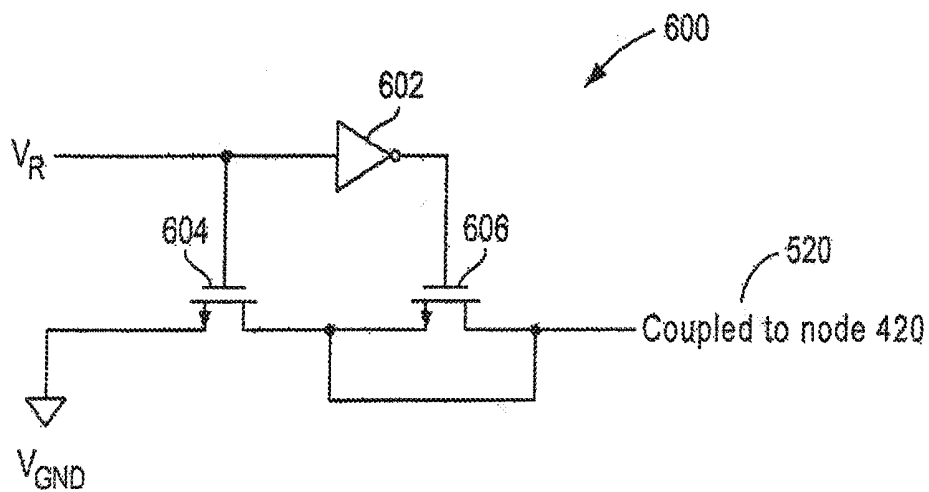

FIG. 10

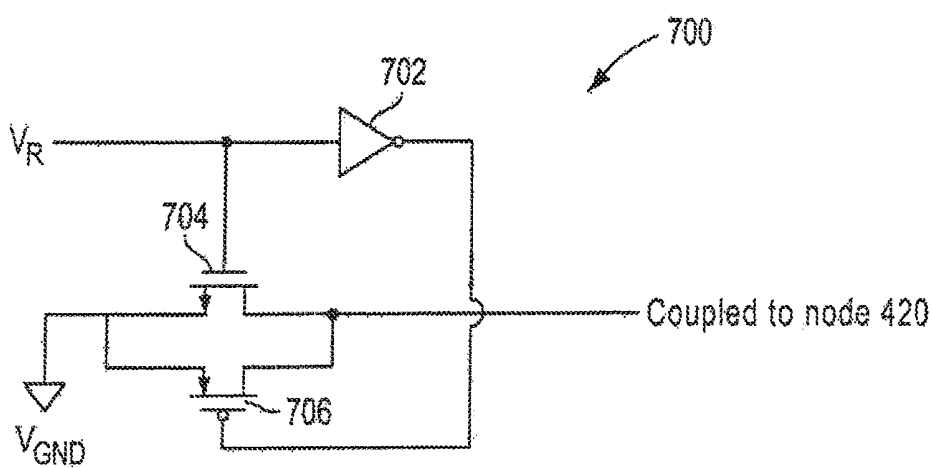

FIG. 11

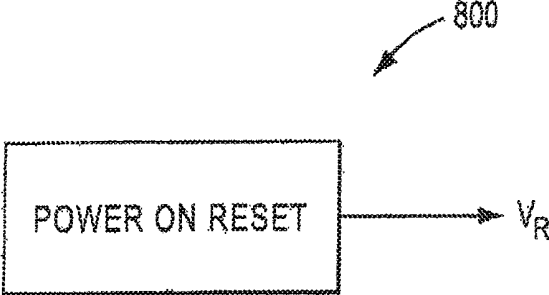

FIG. 12A

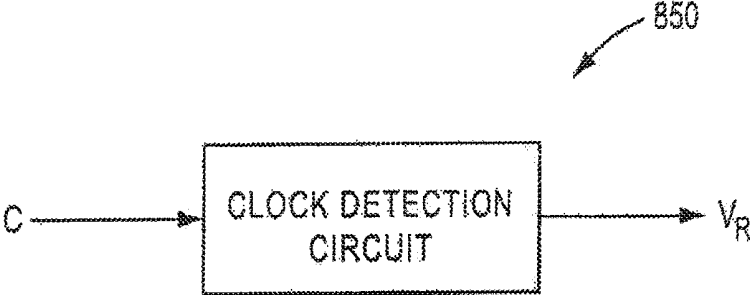

FIG. 12B

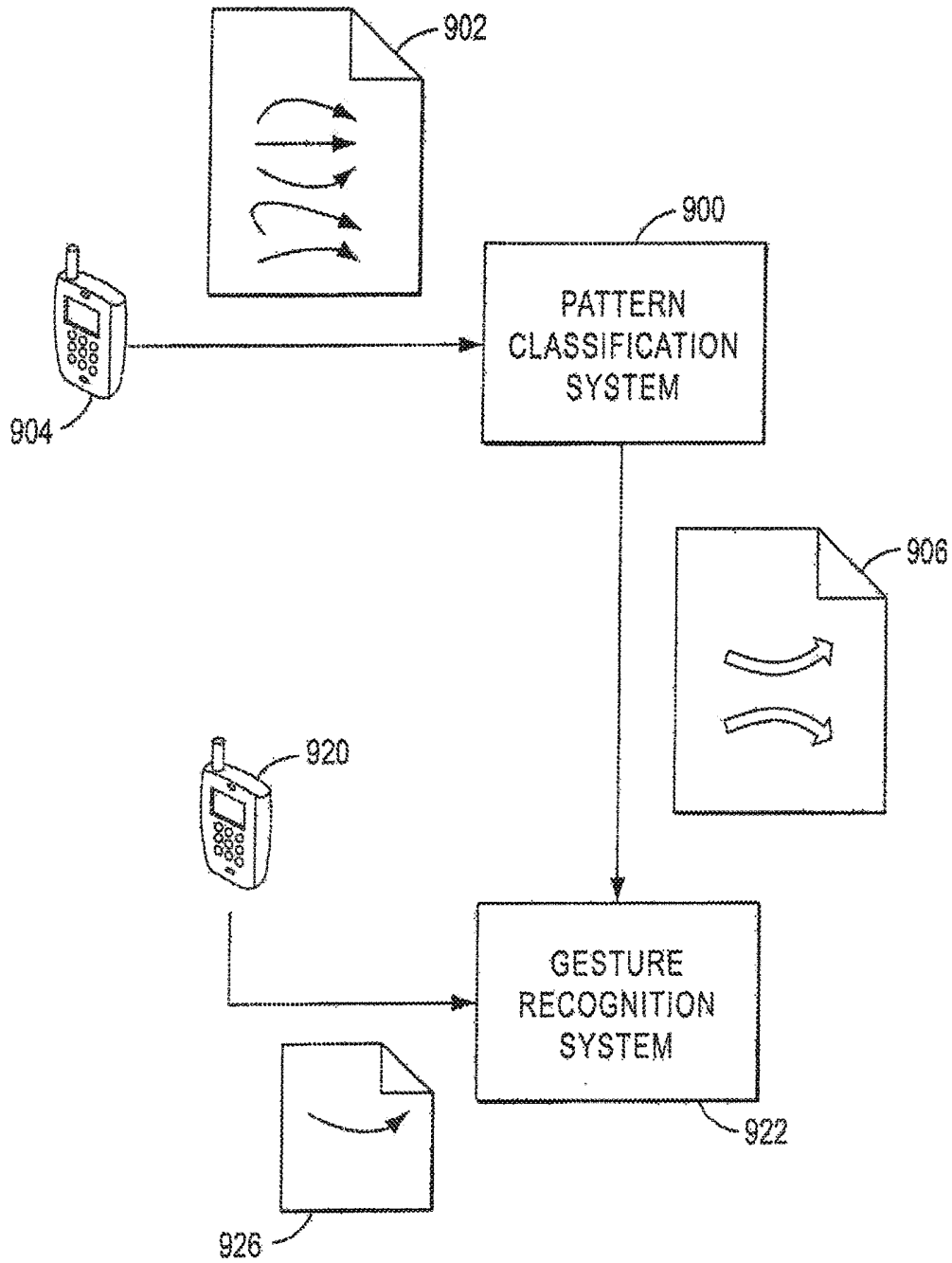

FIG. 13

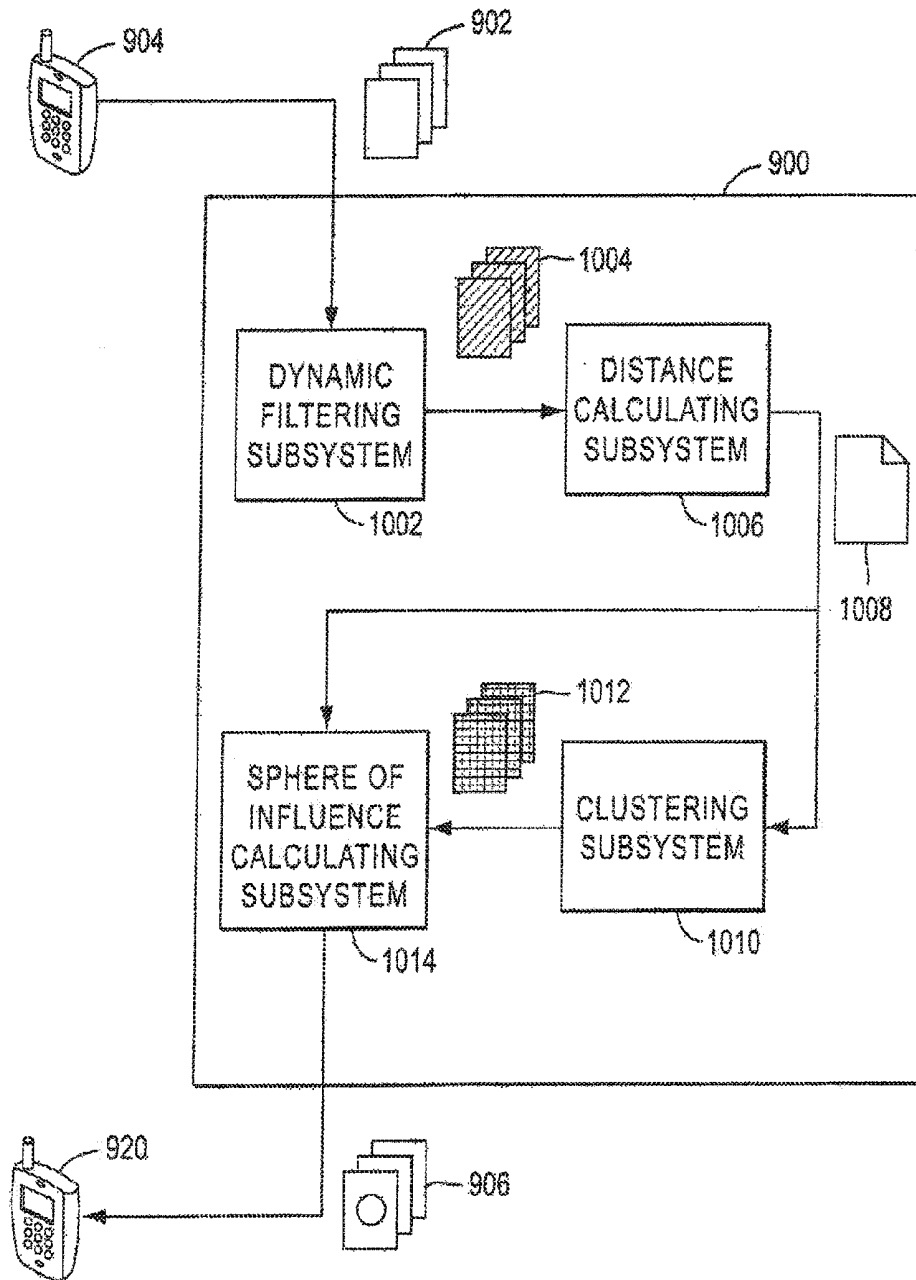

FIG. 14

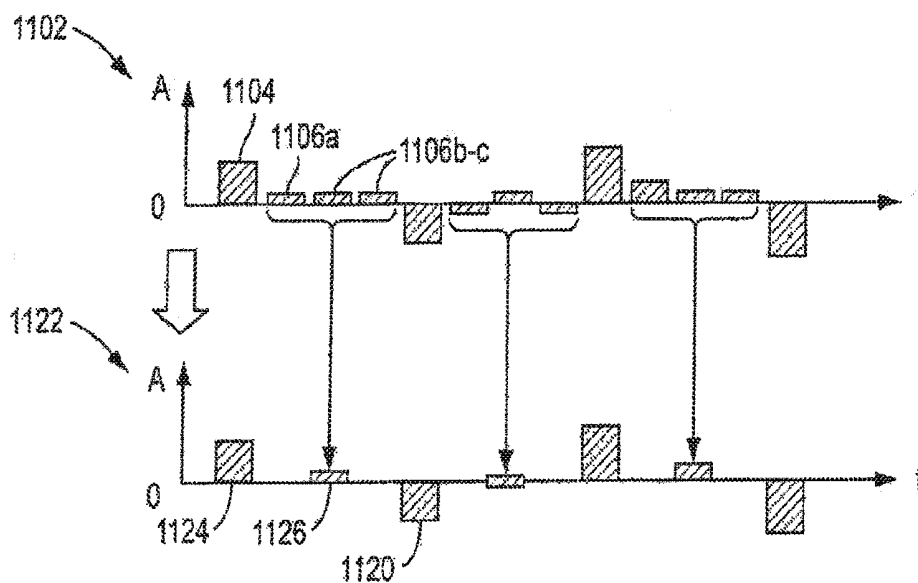

FIG. 15

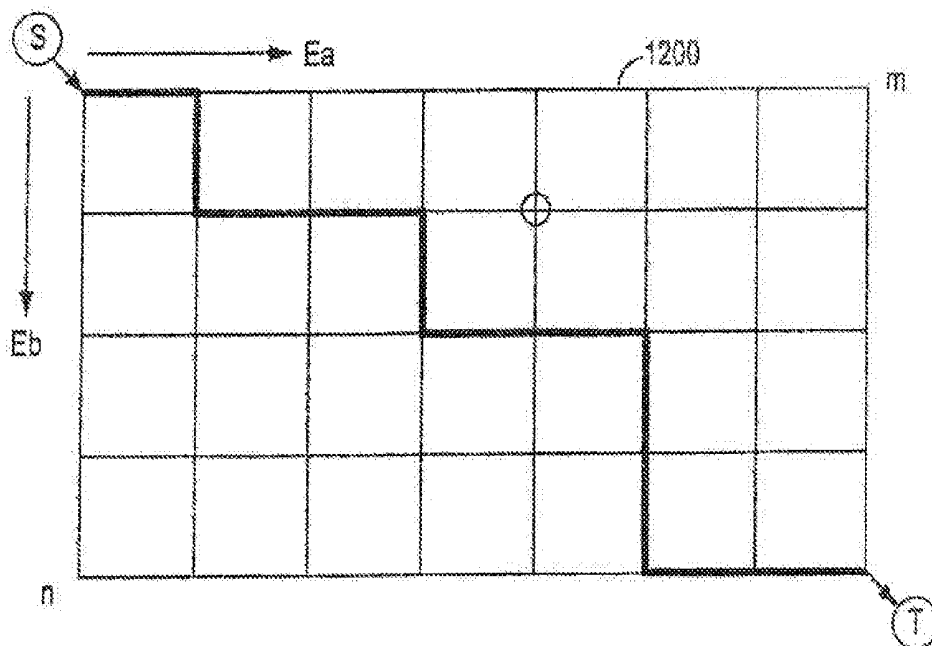

FIG. 16

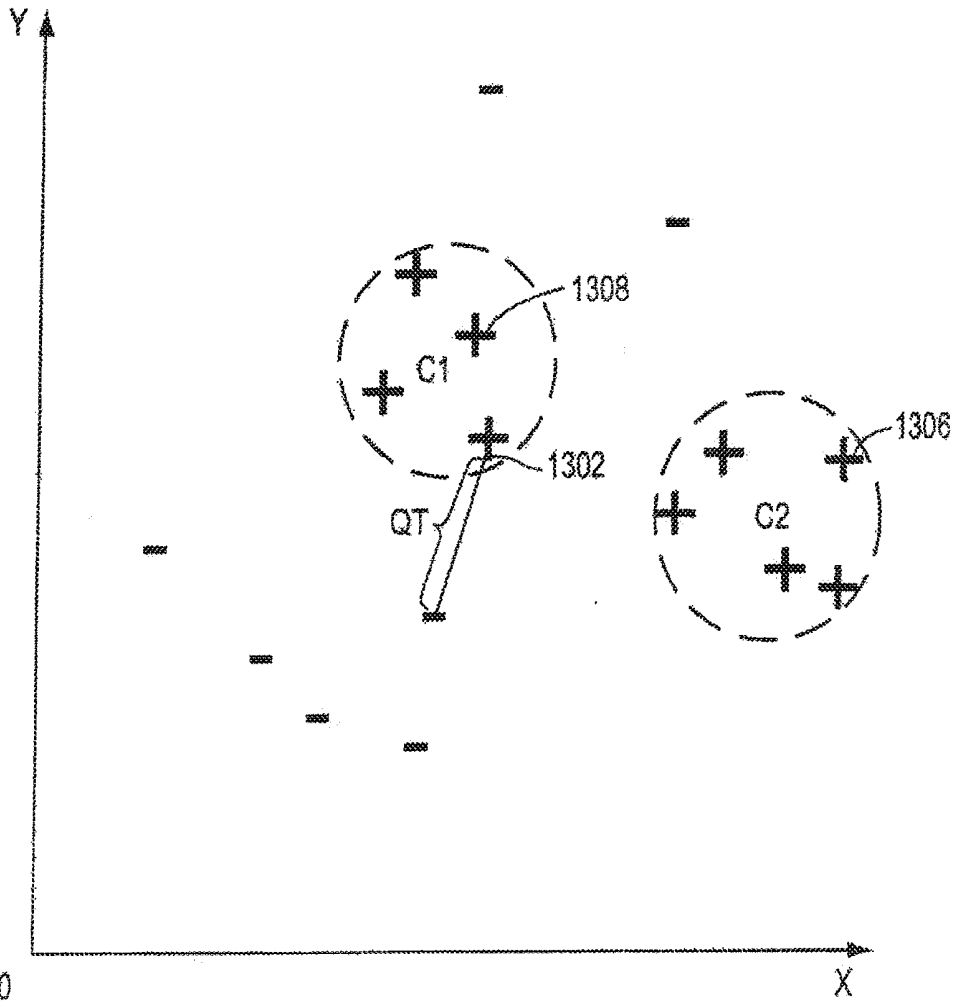

FIG. 17

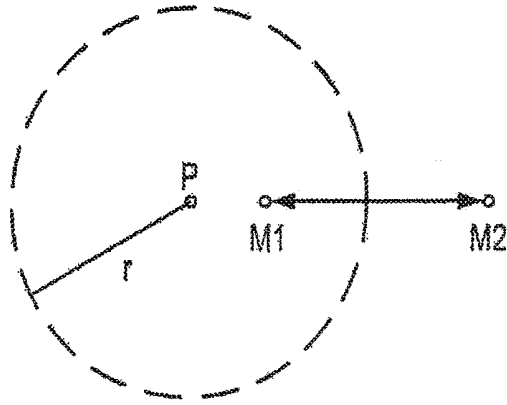

FIG. 18A

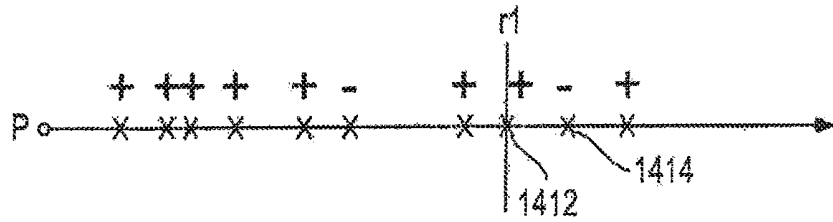

FIG. 18B

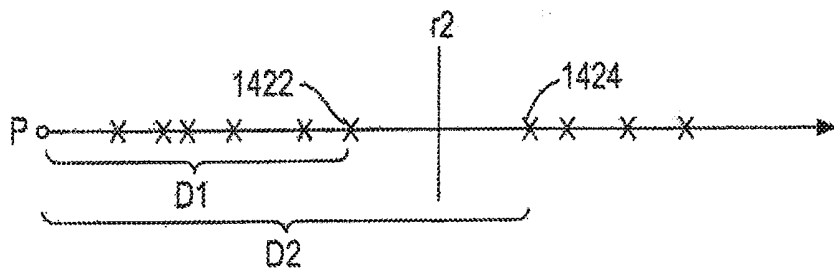

FIG. 18C

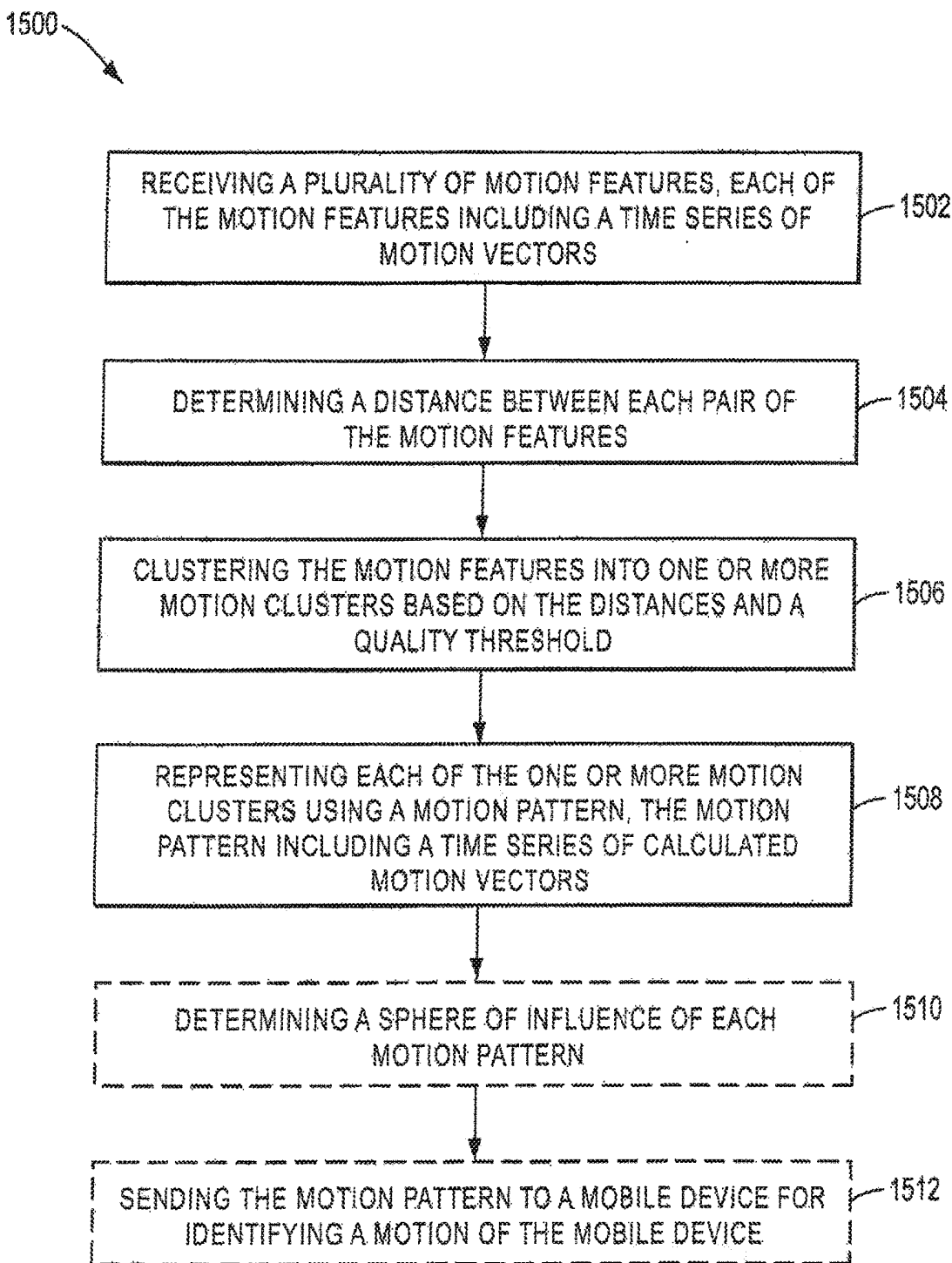

FIG. 19

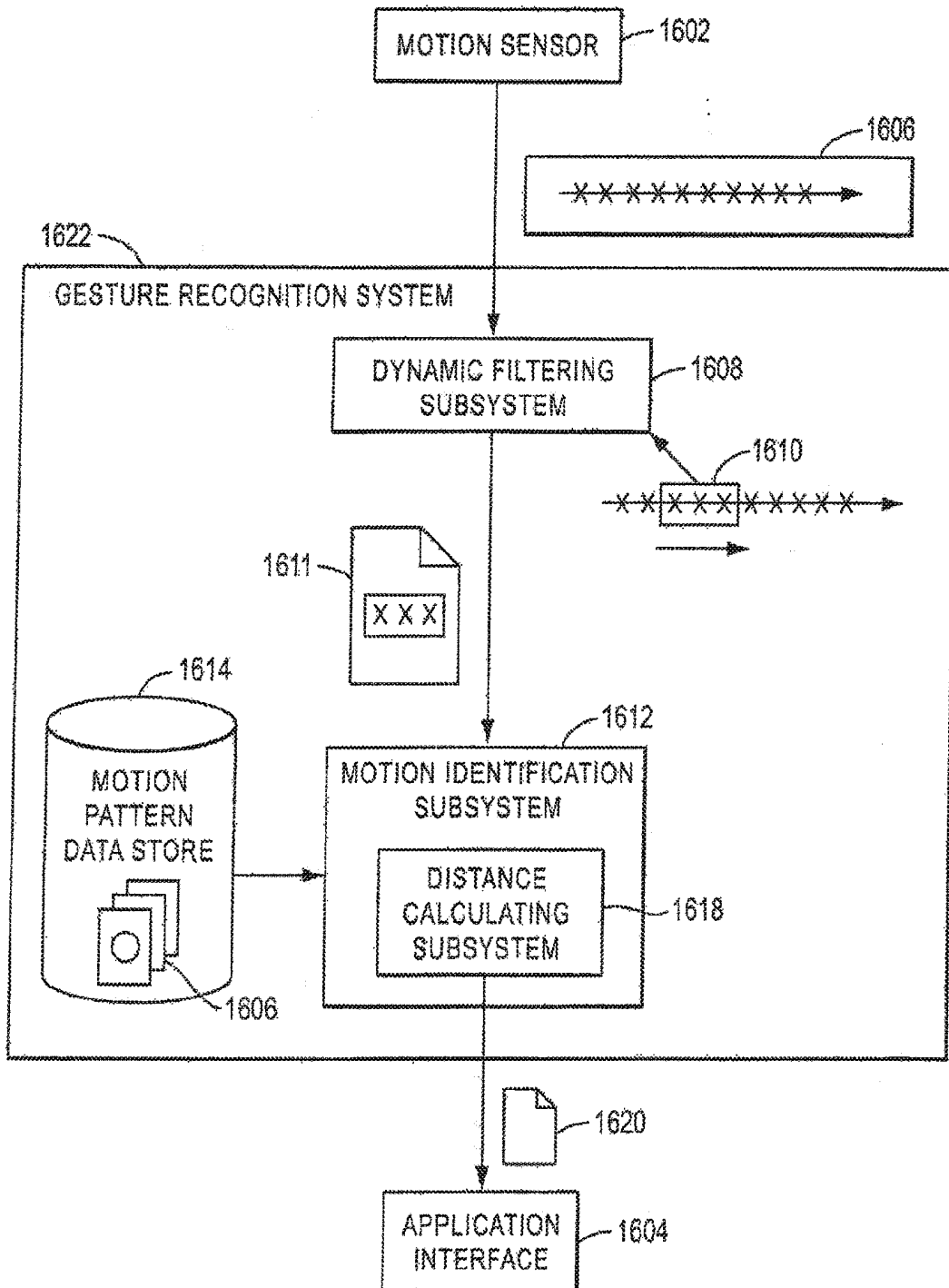

FIG. 20

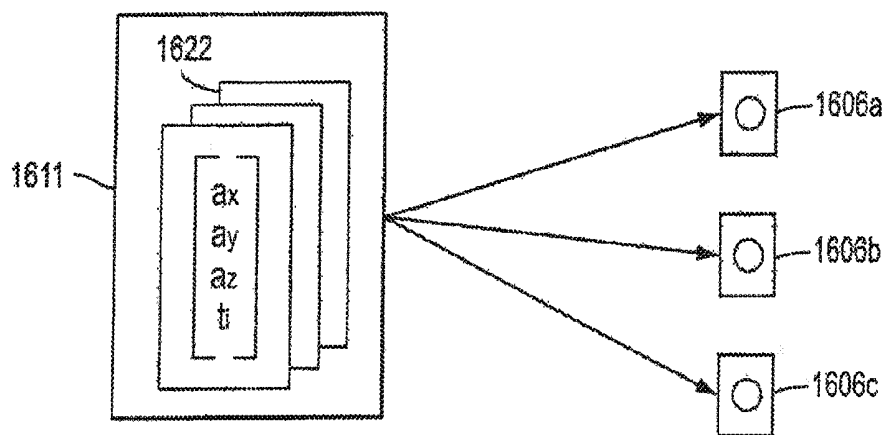

FIG. 21A

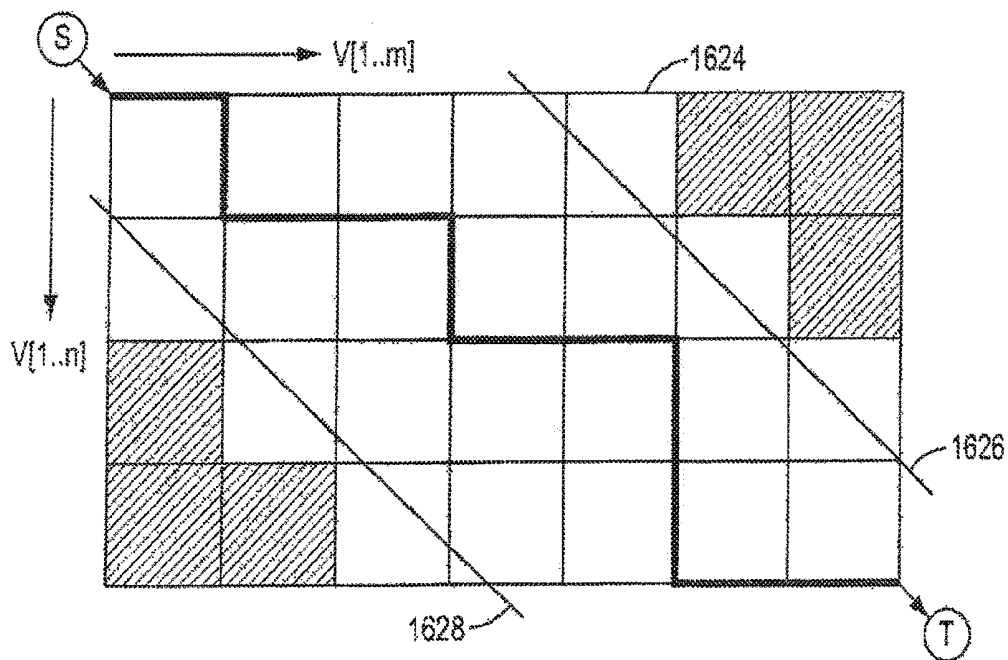

FIG. 21B

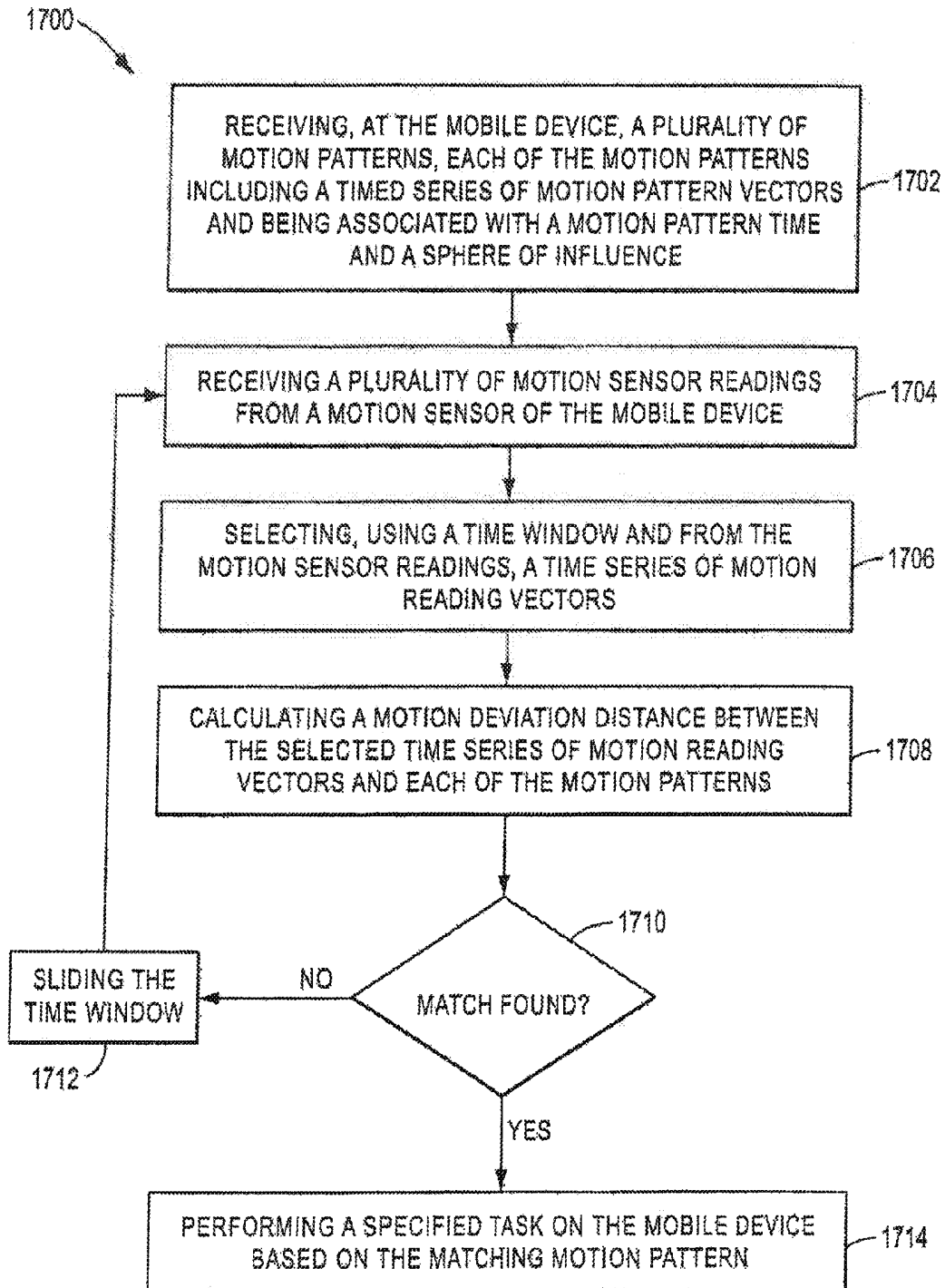

FIG. 22

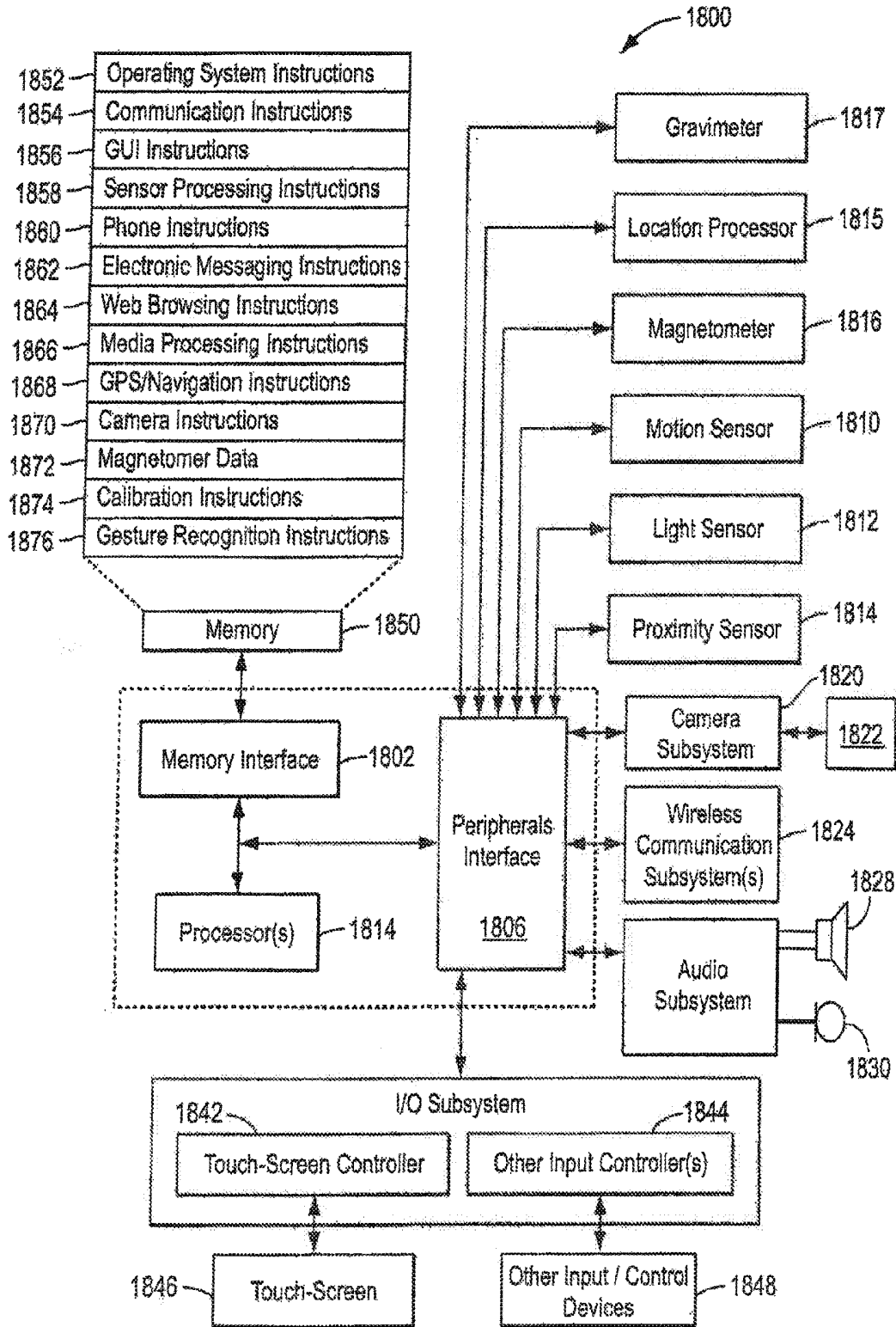

FIG. 23

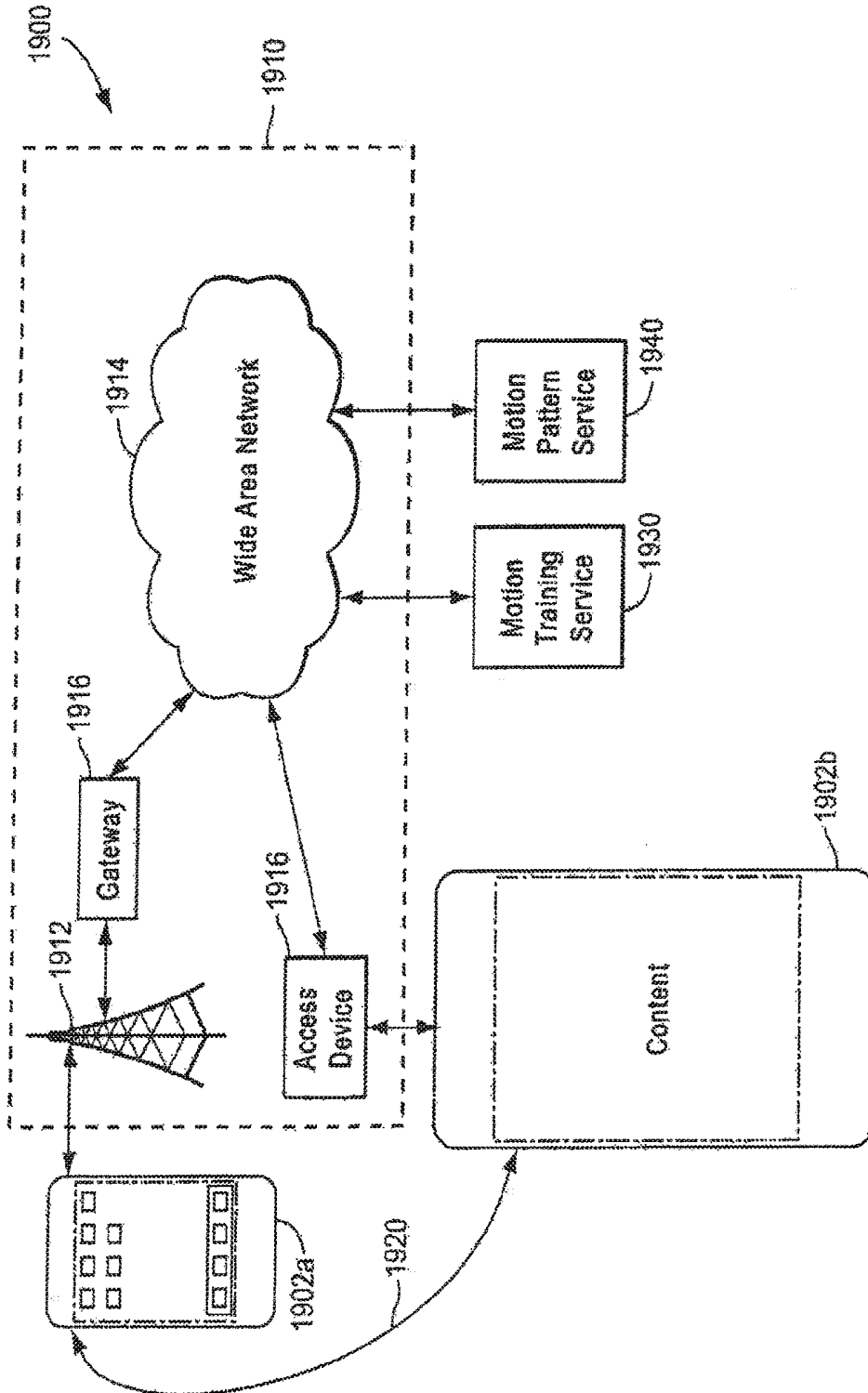

FIG. 24

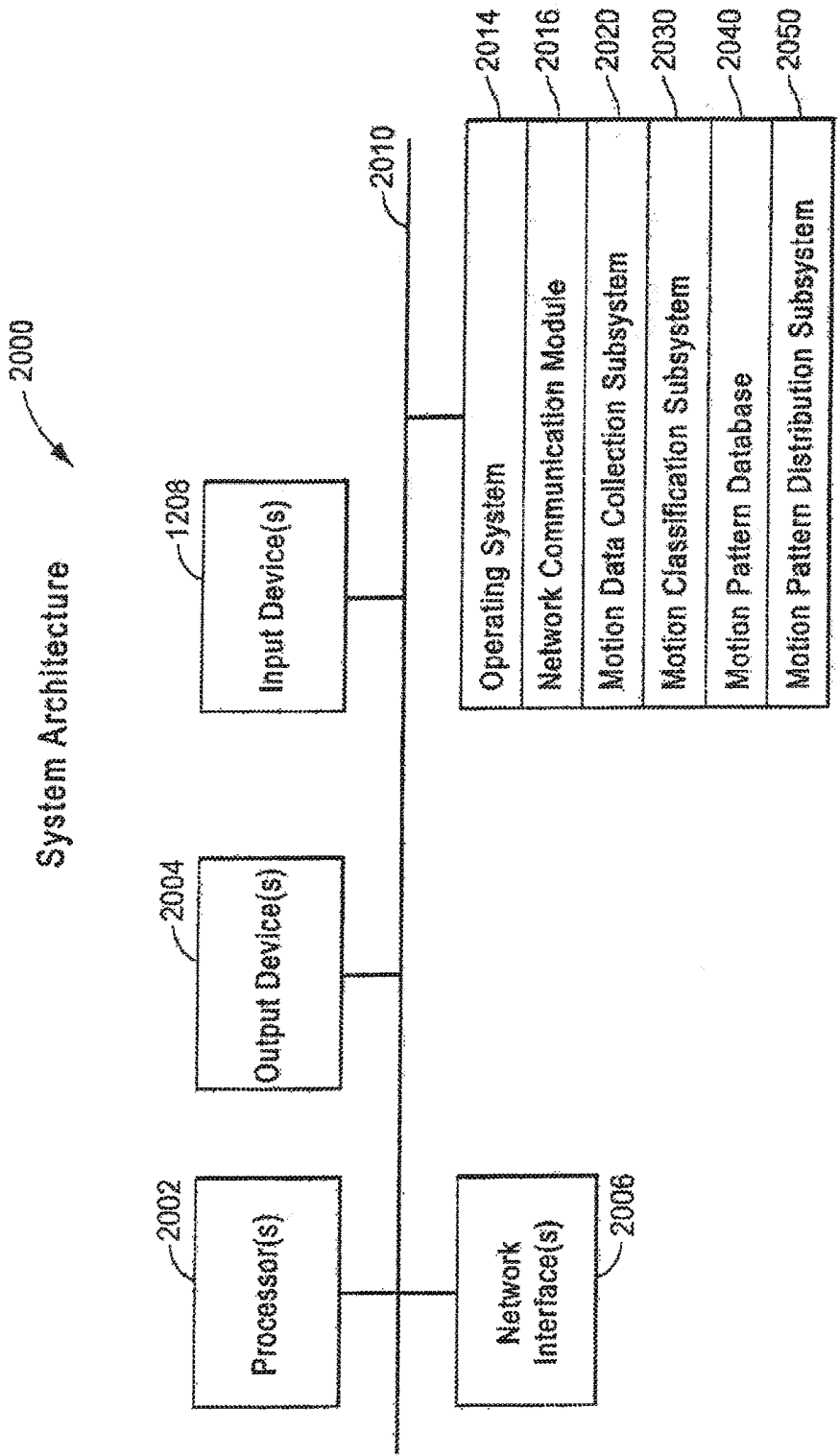

FIG. 25

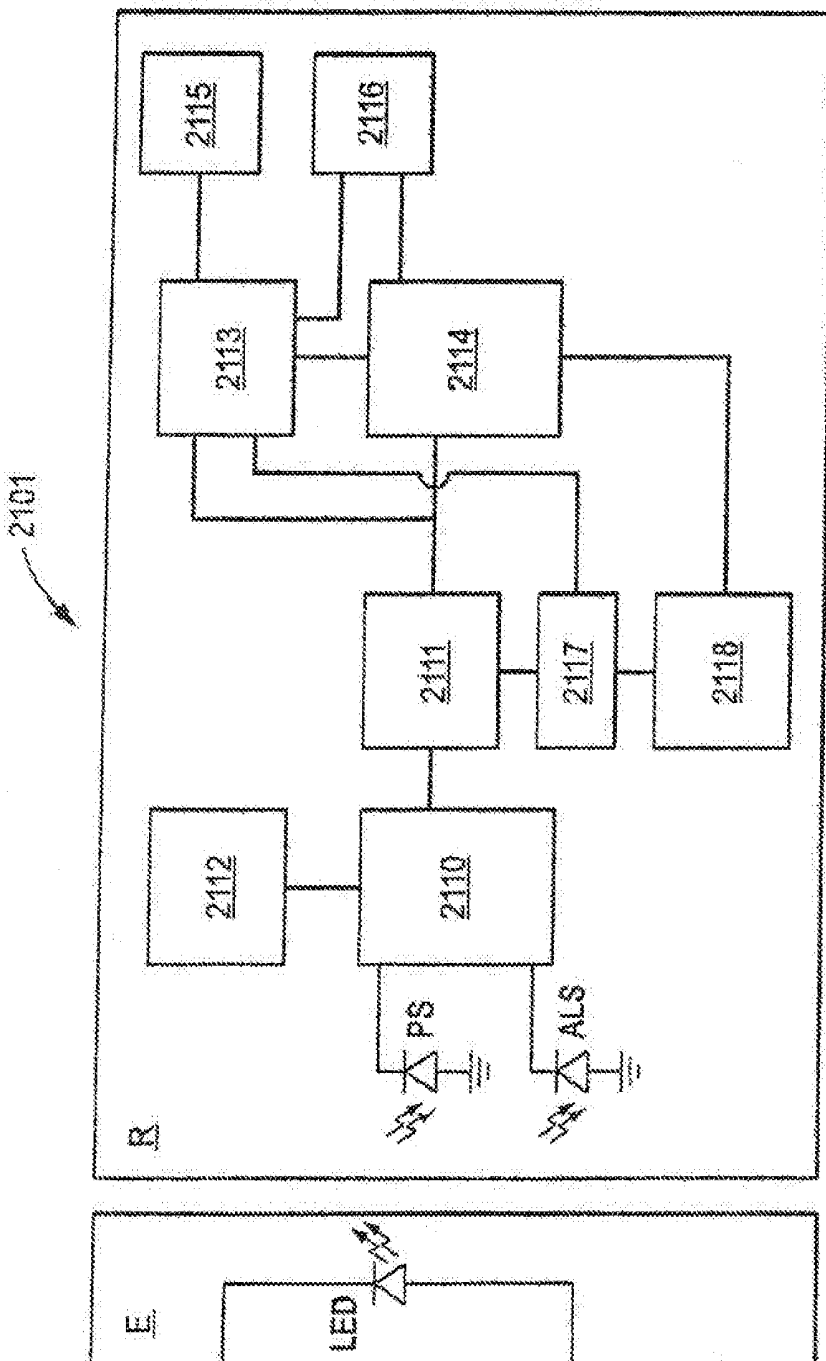

FIG. 26

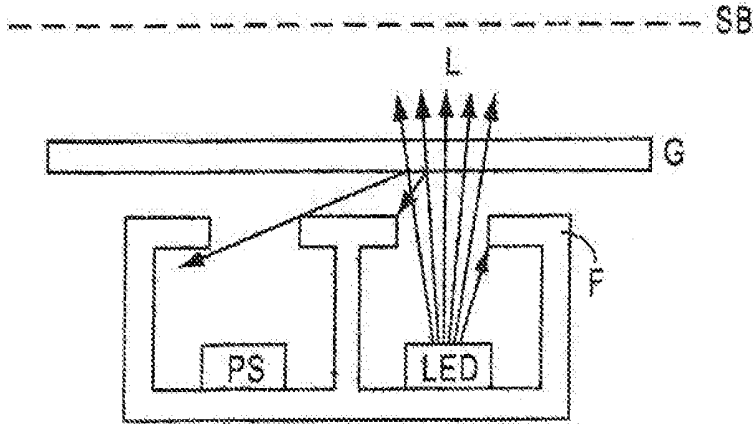

FIG. 27A

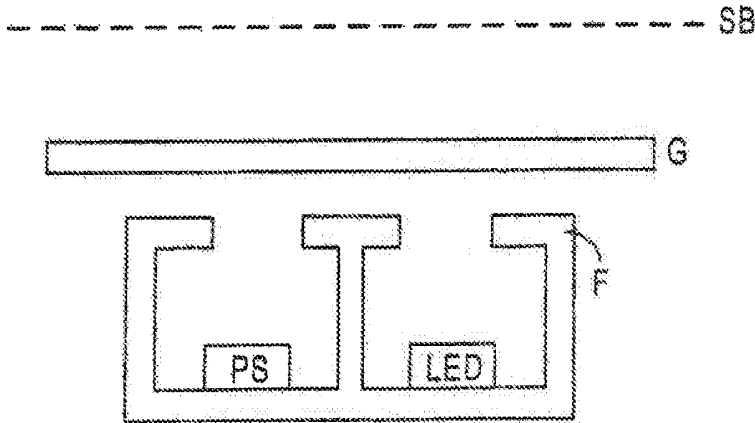

FIG. 27B

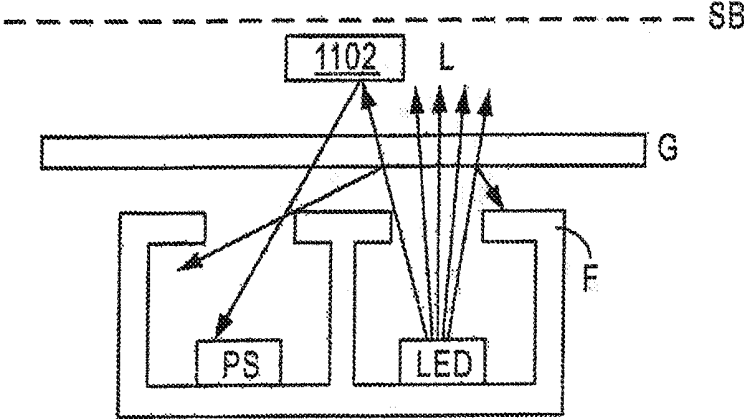

FIG. 27C

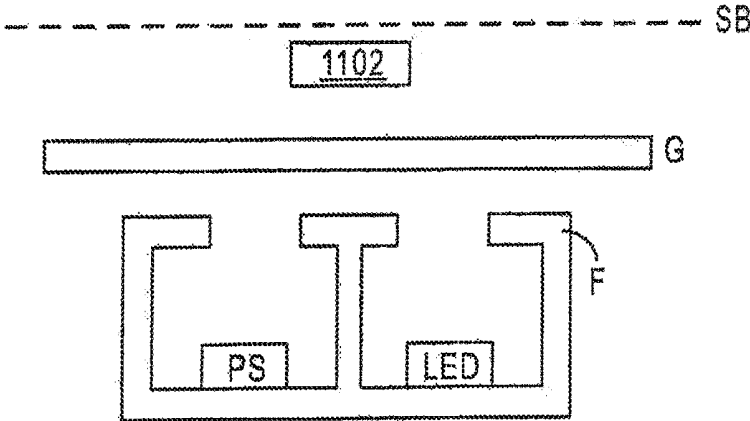

FIG. 27D

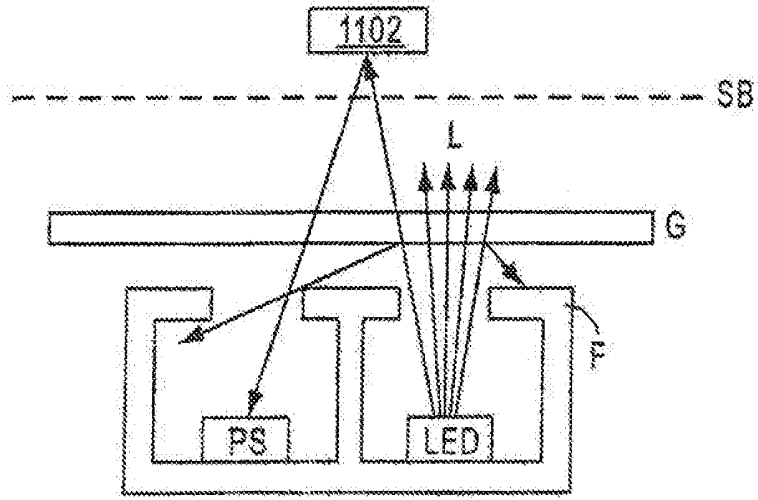

FIG. 27E

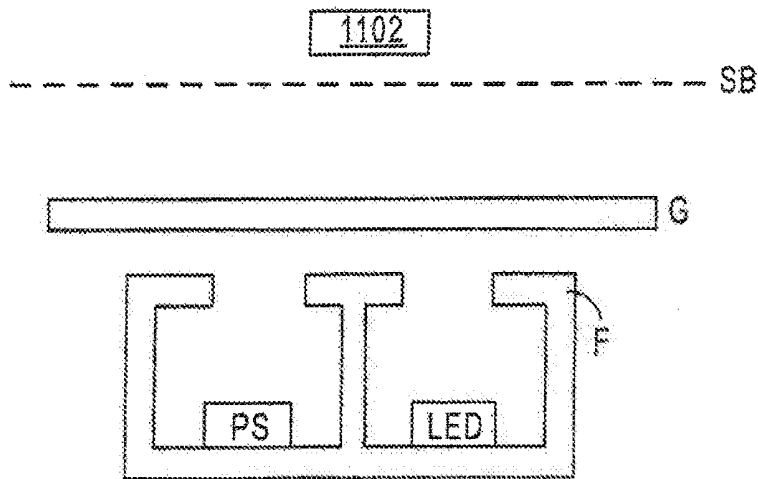

FIG. 27F

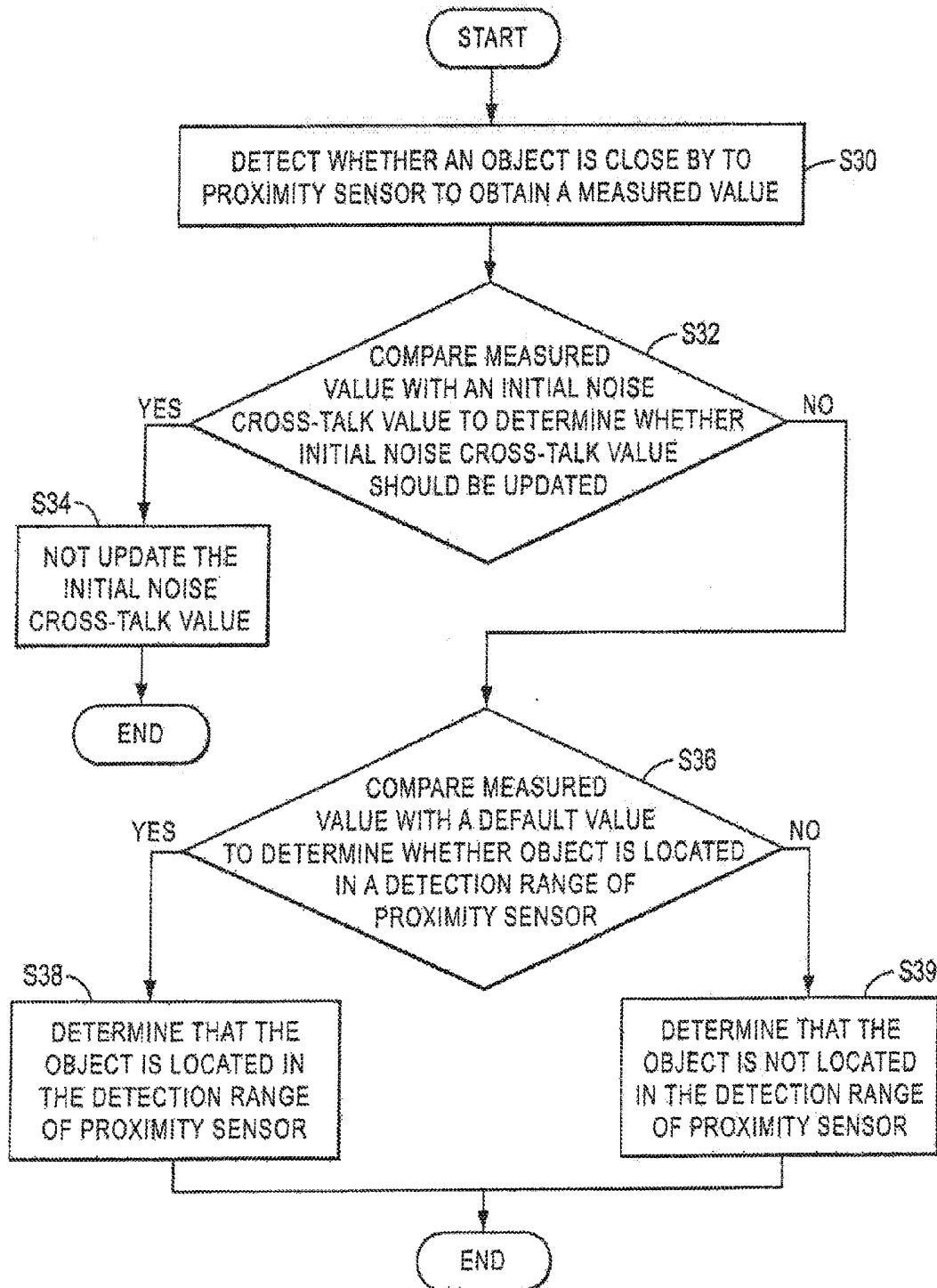

FIG. 28

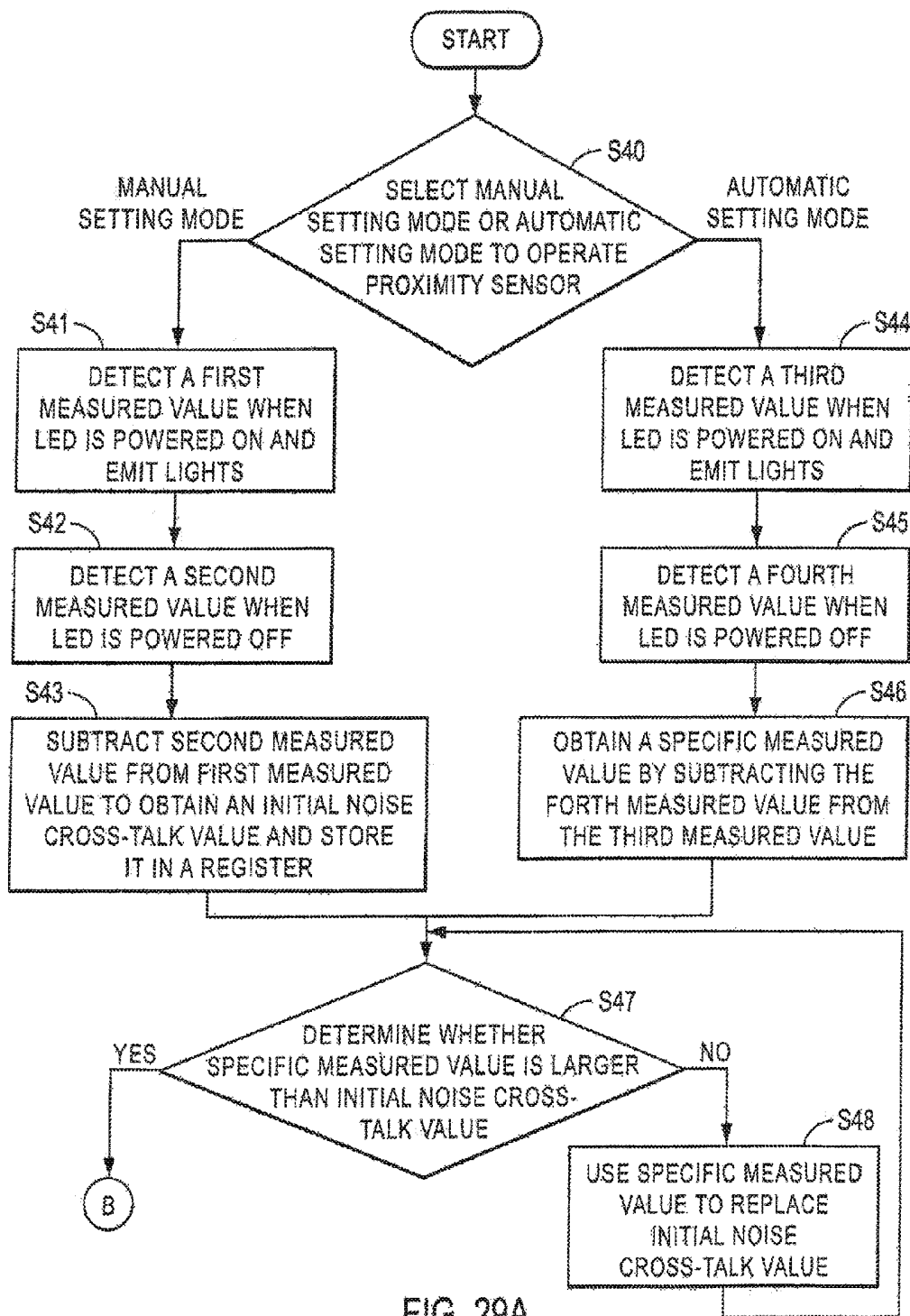

FIG. 29A

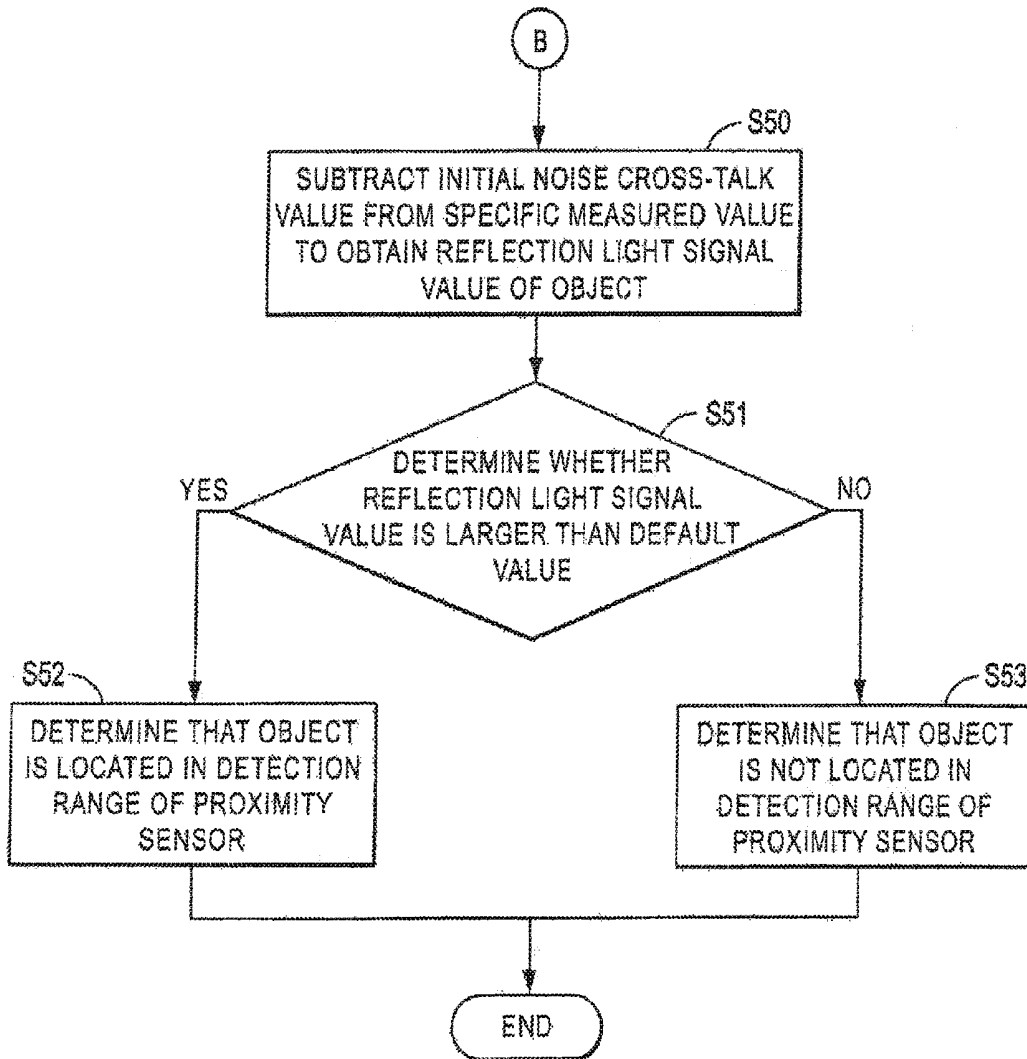

FIG. 29B

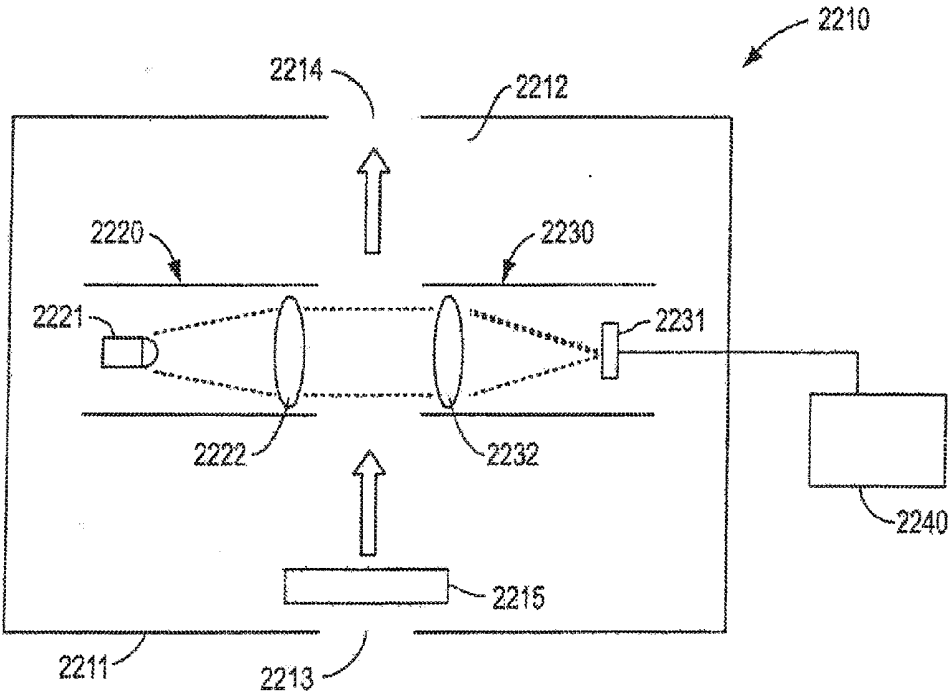

FIG. 30

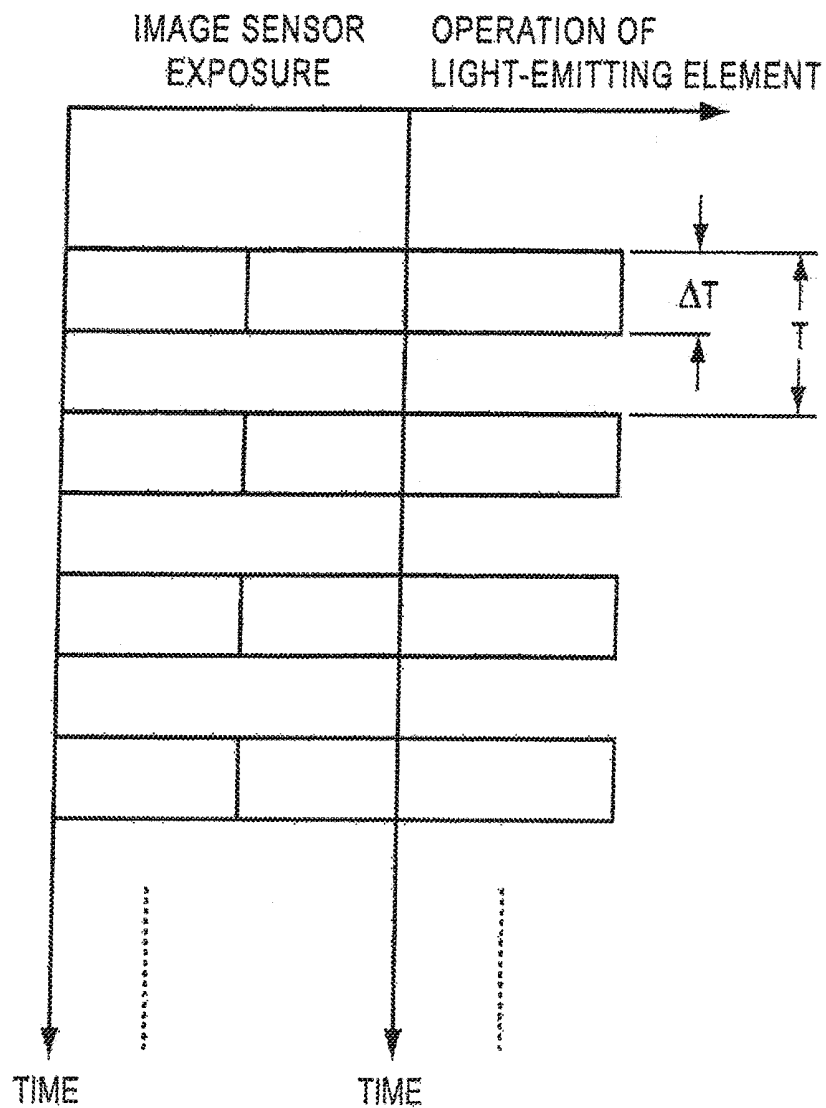

FIG. 31

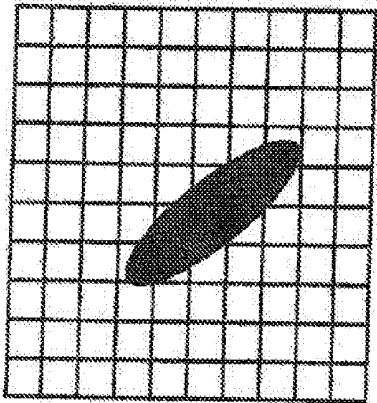

FIG. 32A

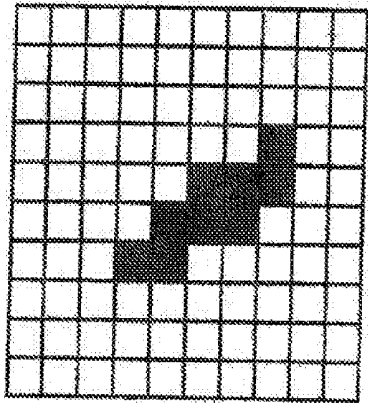

FIG. 32B

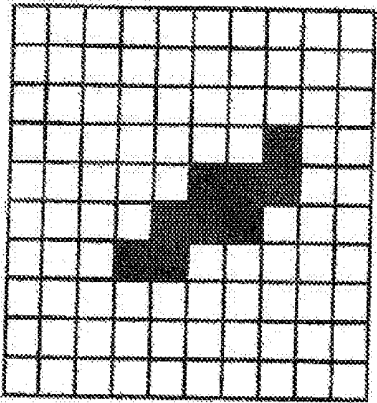

FIG. 33A

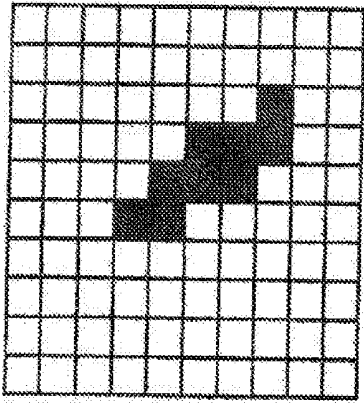

FIG. 33B

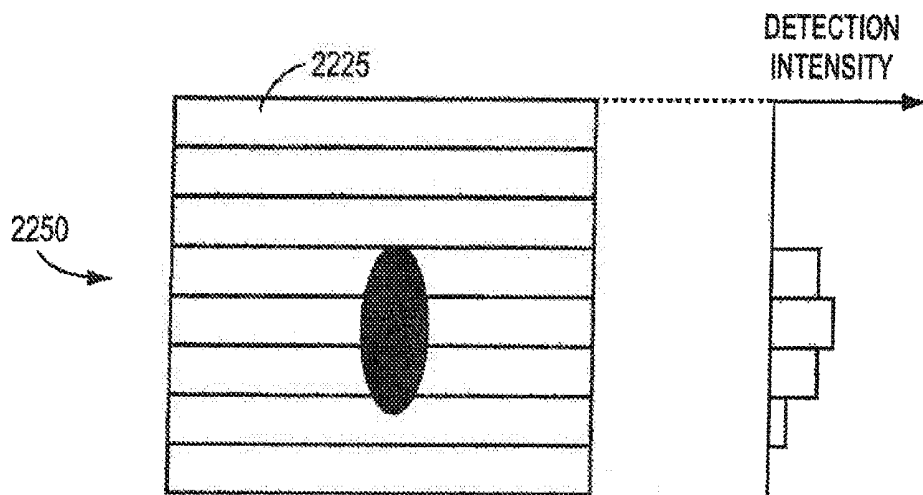

FIG. 34A

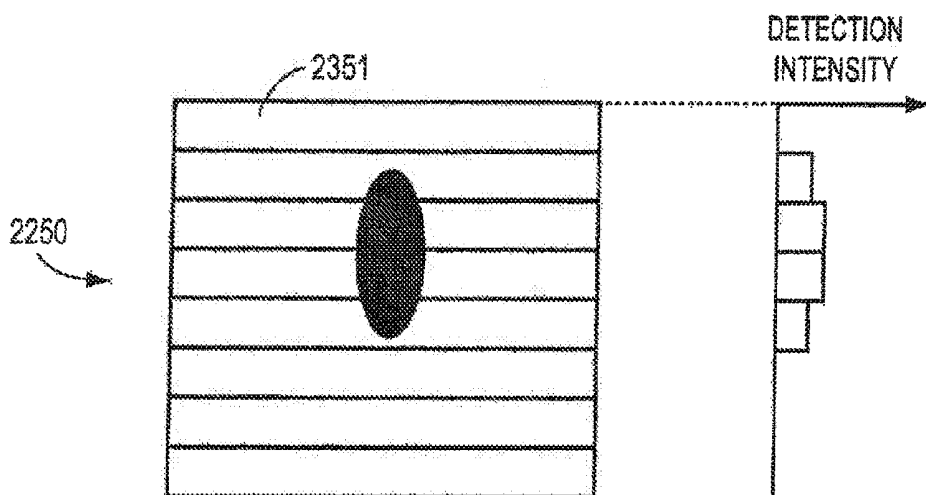

FIG. 34B

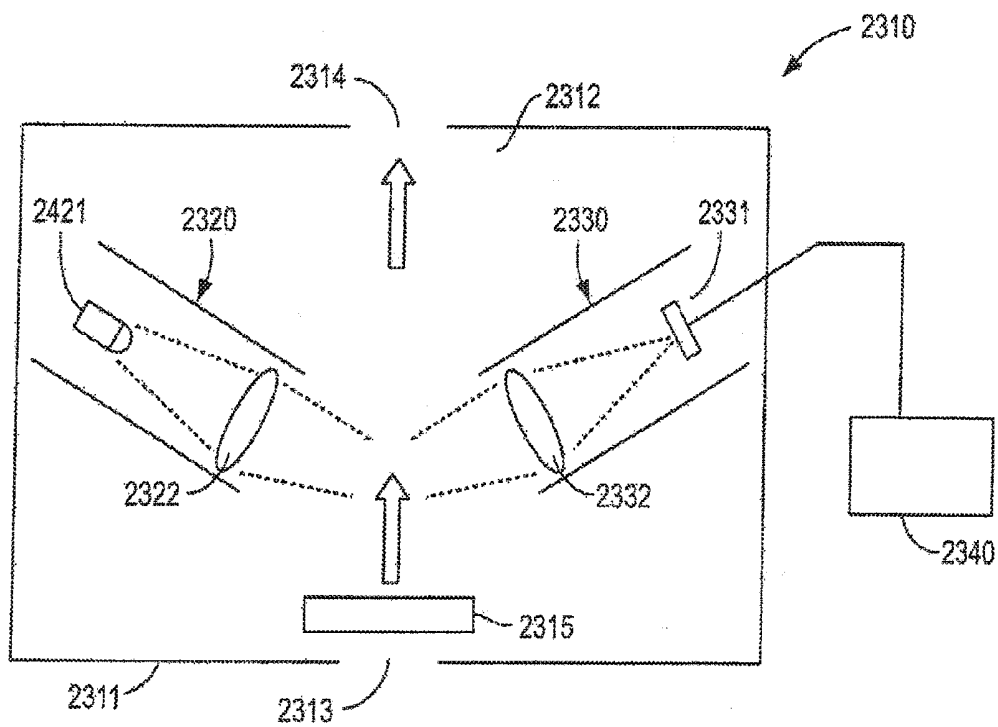

FIG. 35

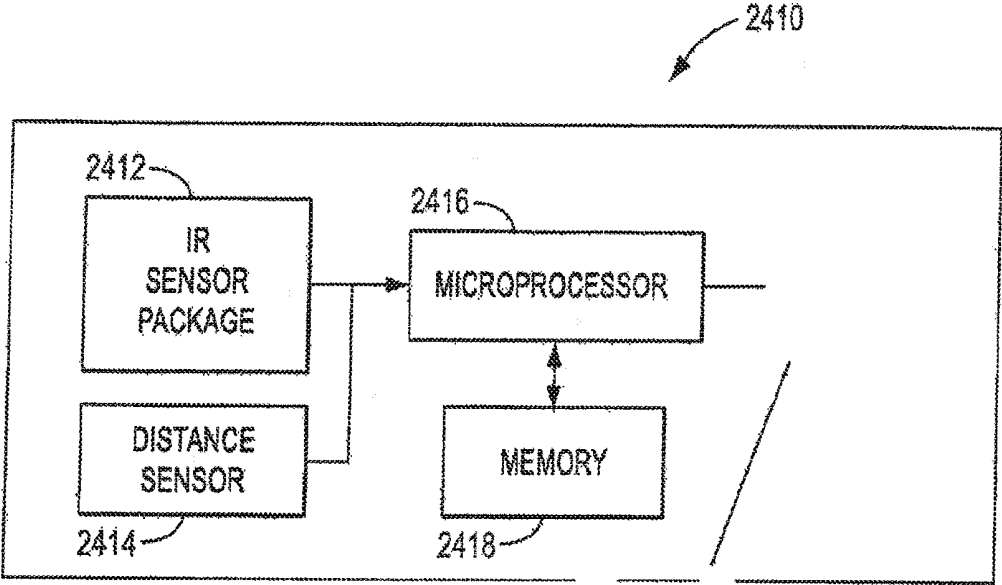

FIG. 36

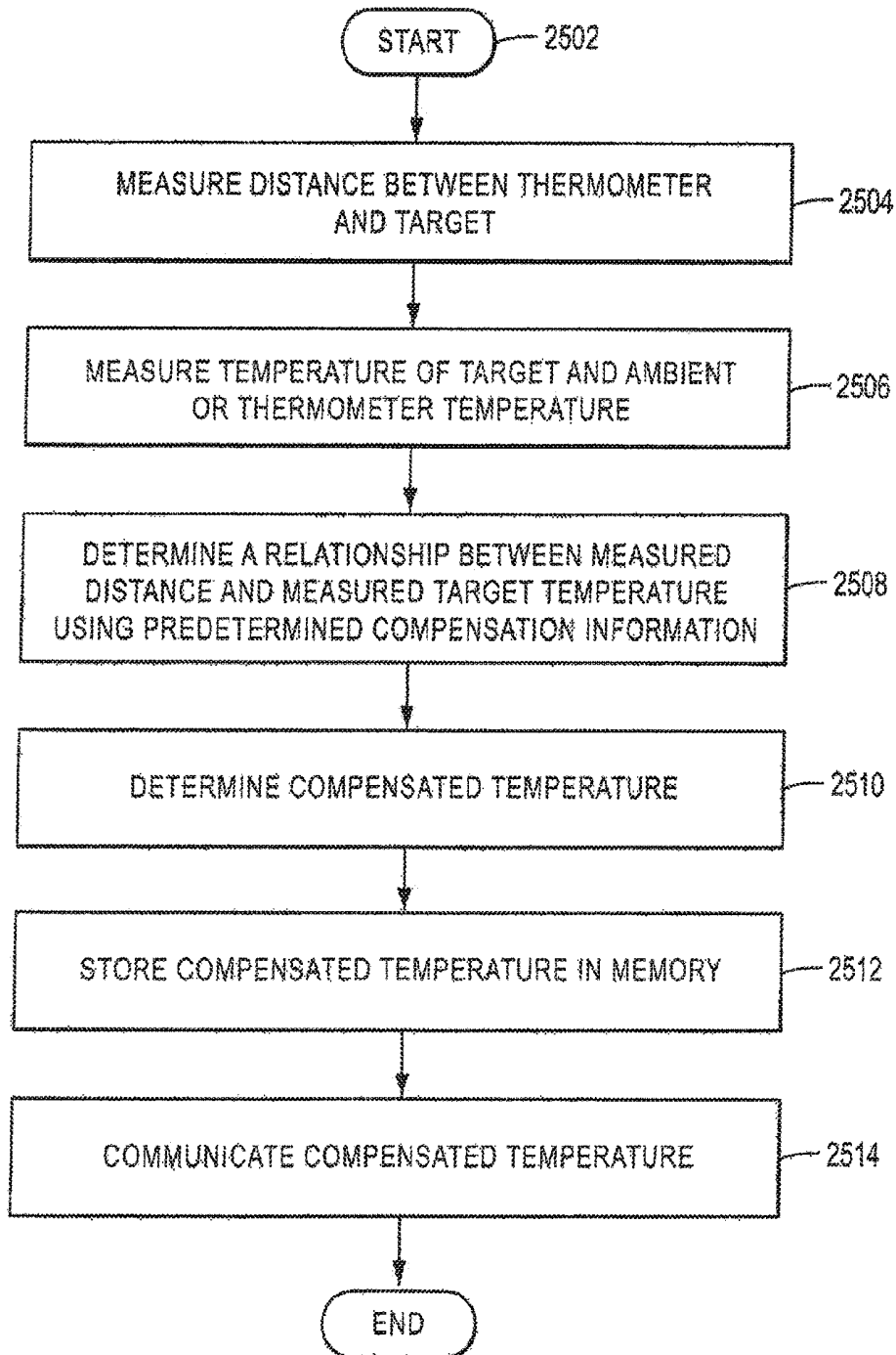

FIG. 37

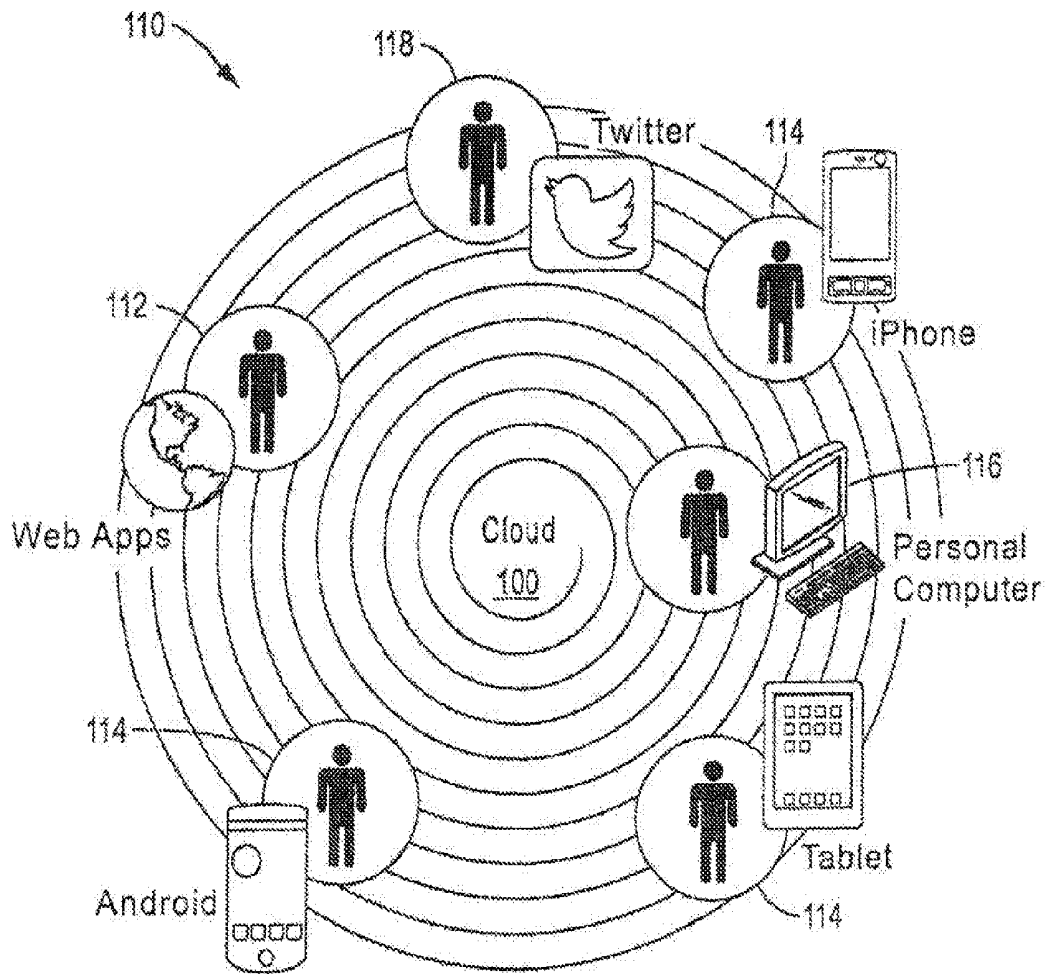

FIG. 38A

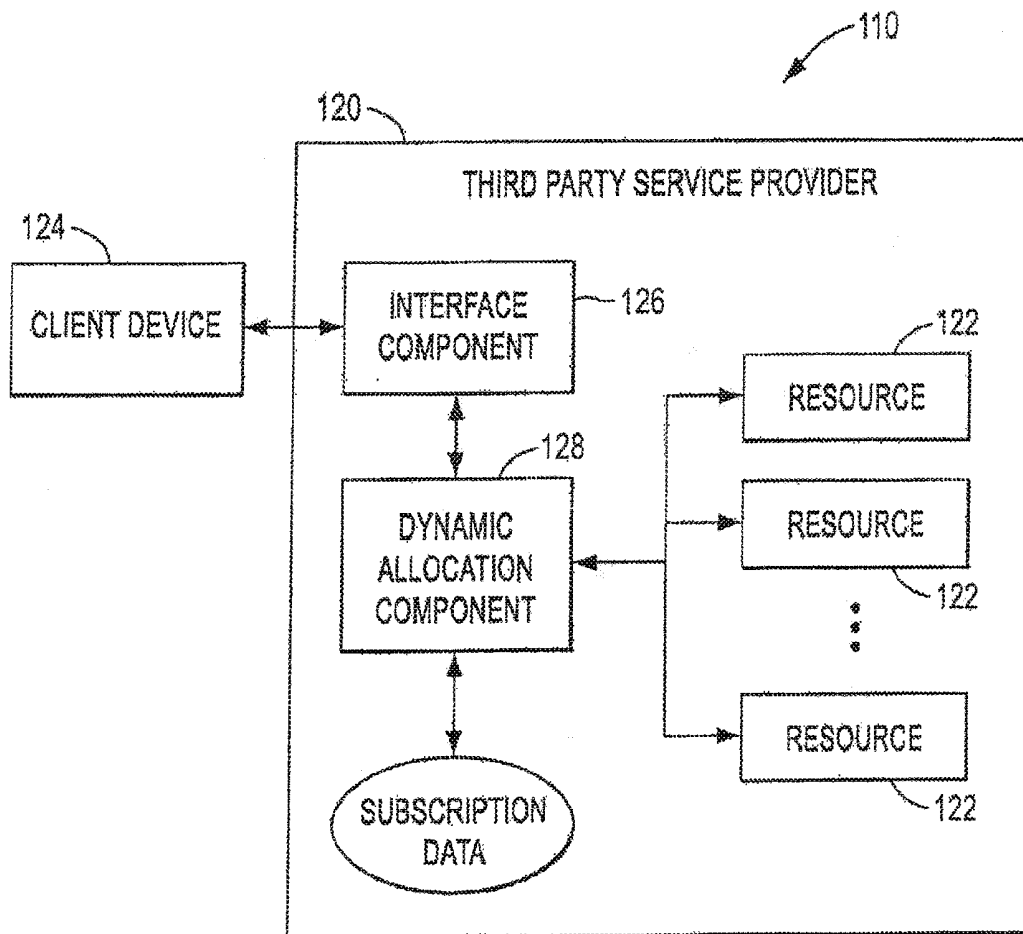

FIG. 38B

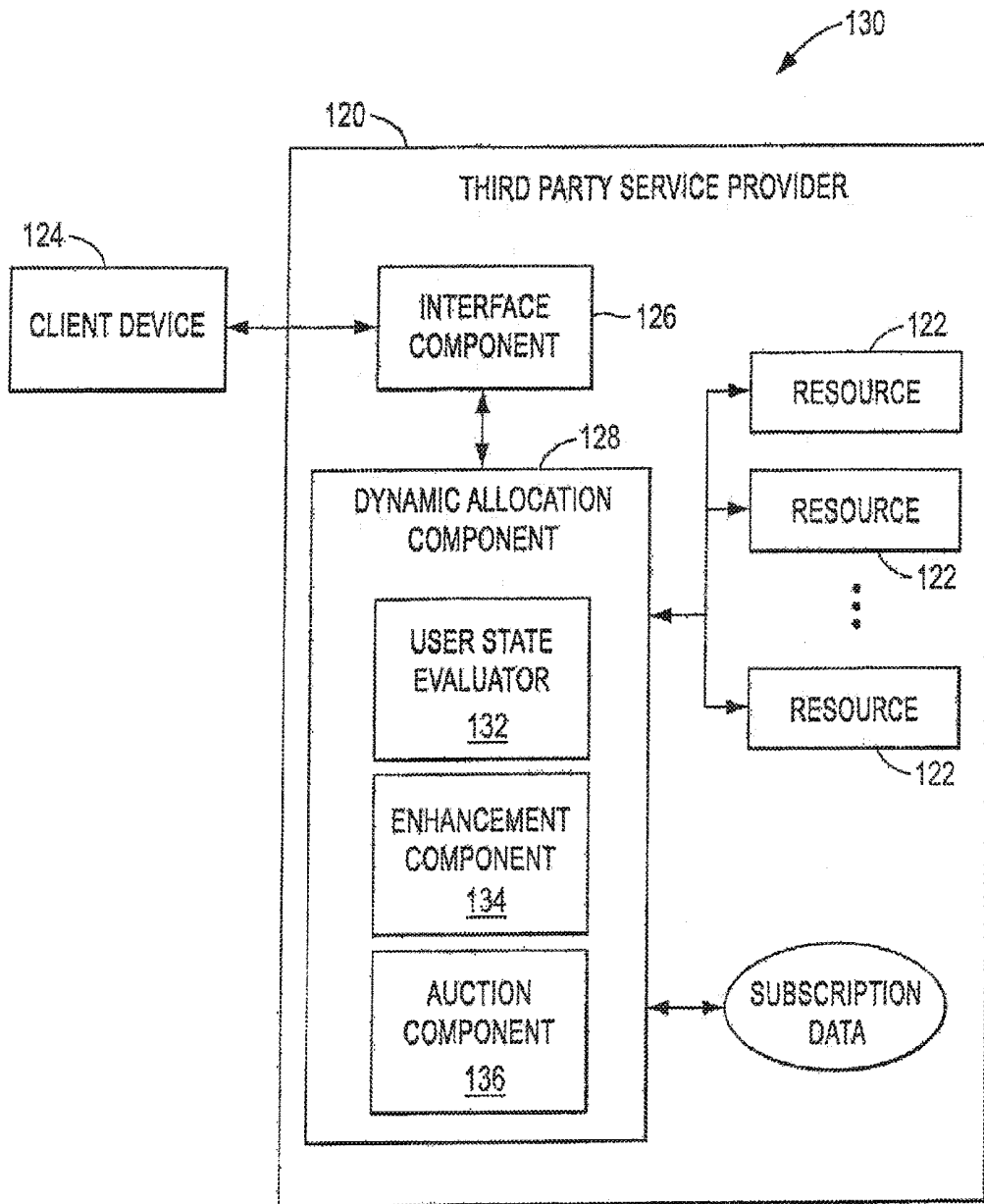

FIG. 38C

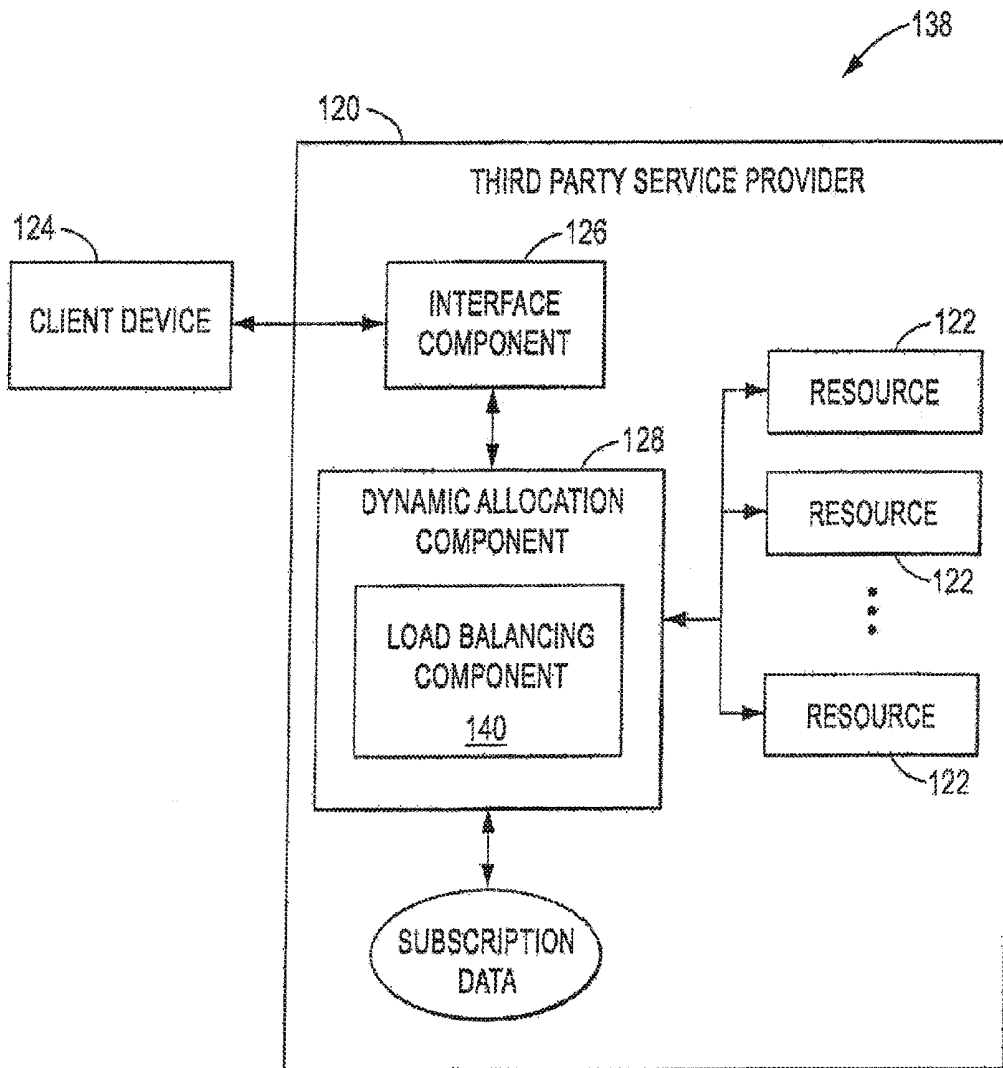

FIG. 38D

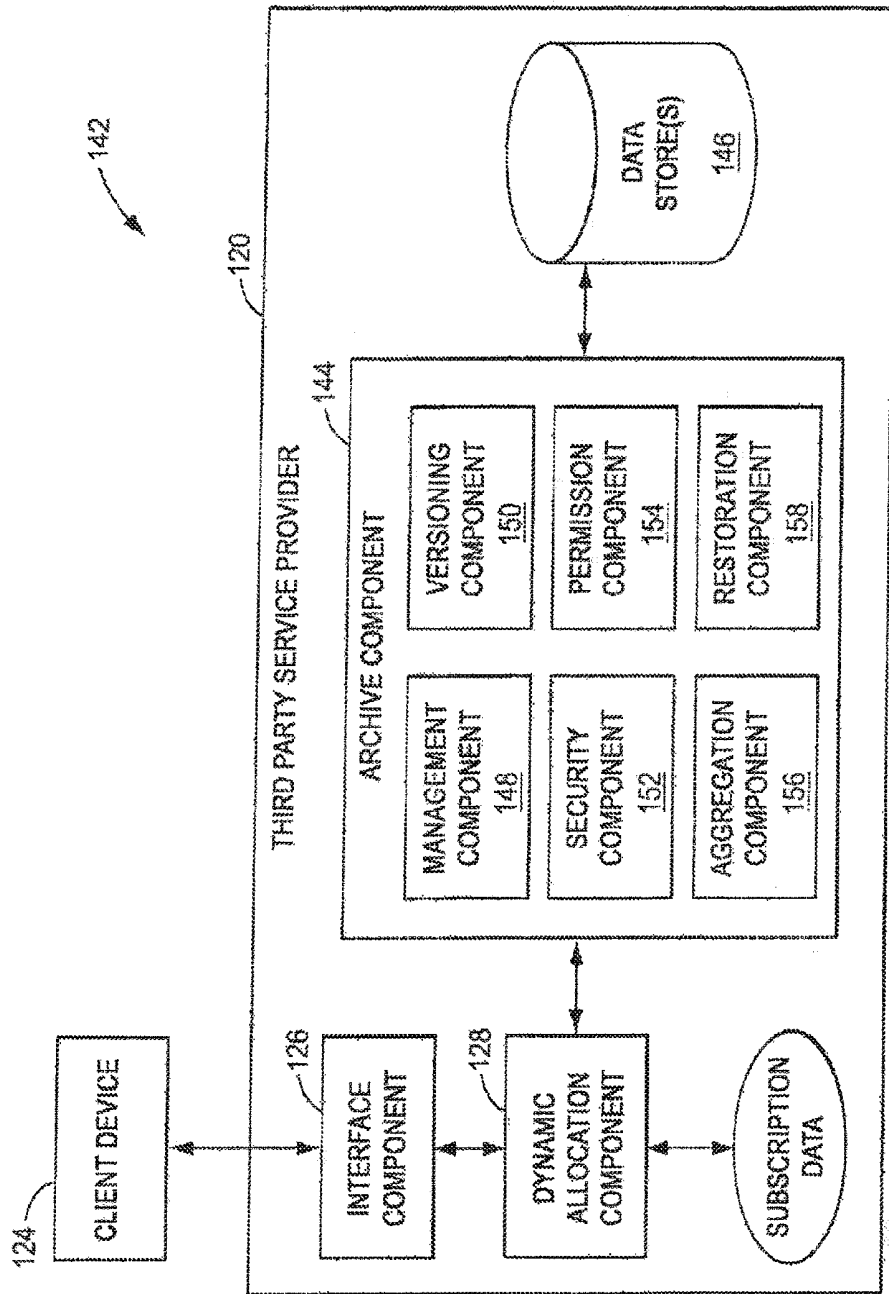

FIG. 38E

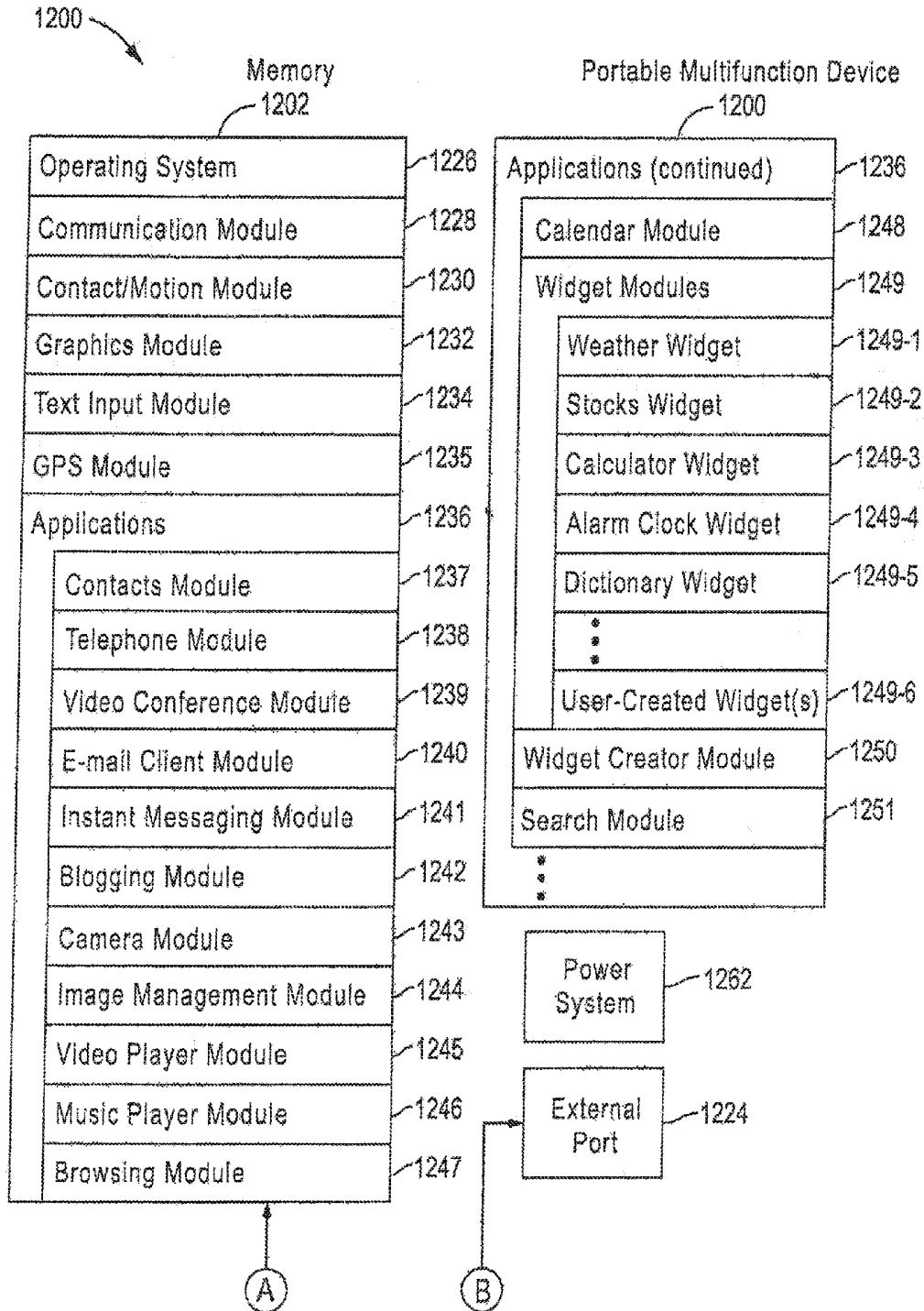

FIG. 39

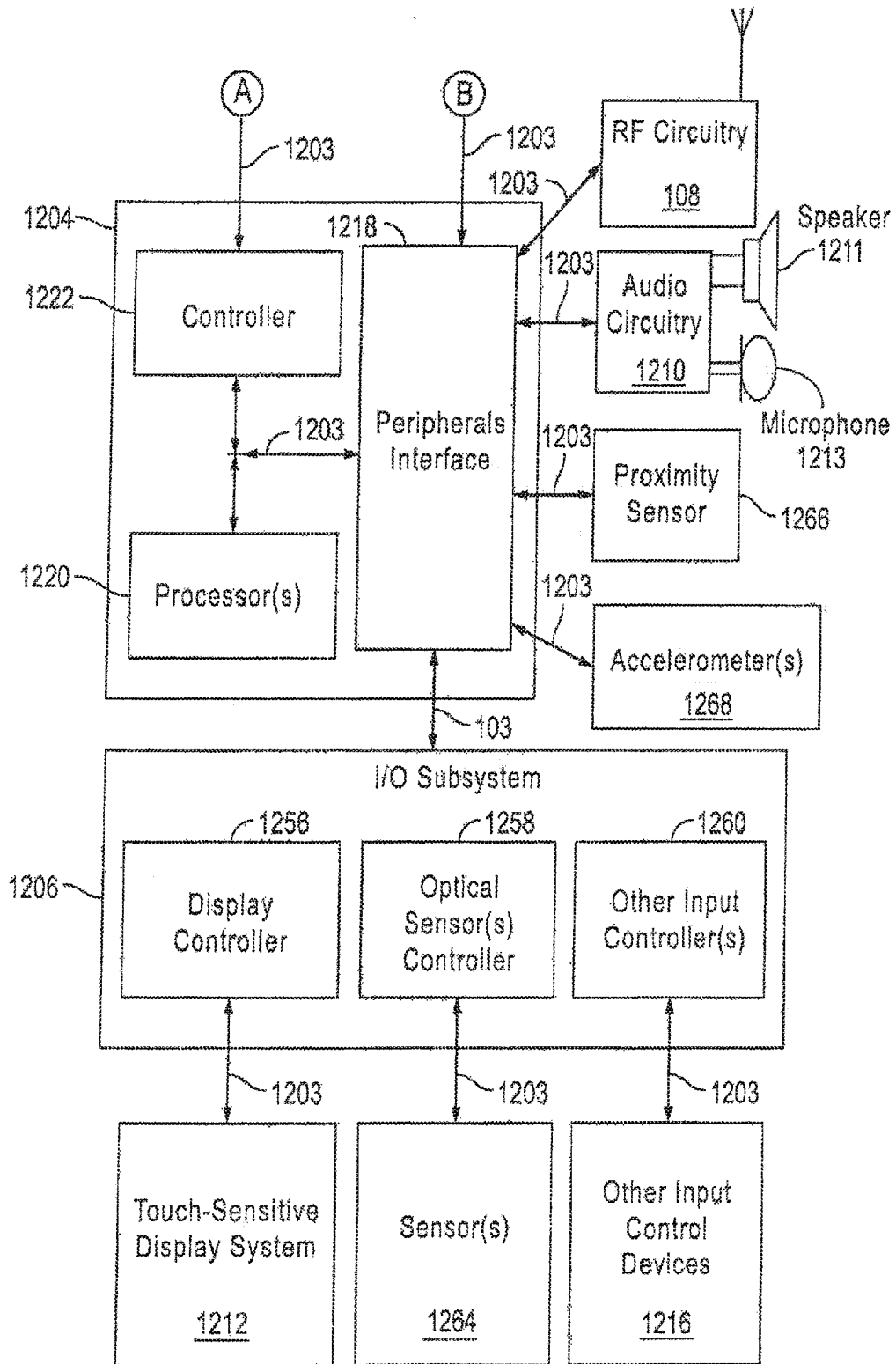

FIG. 40

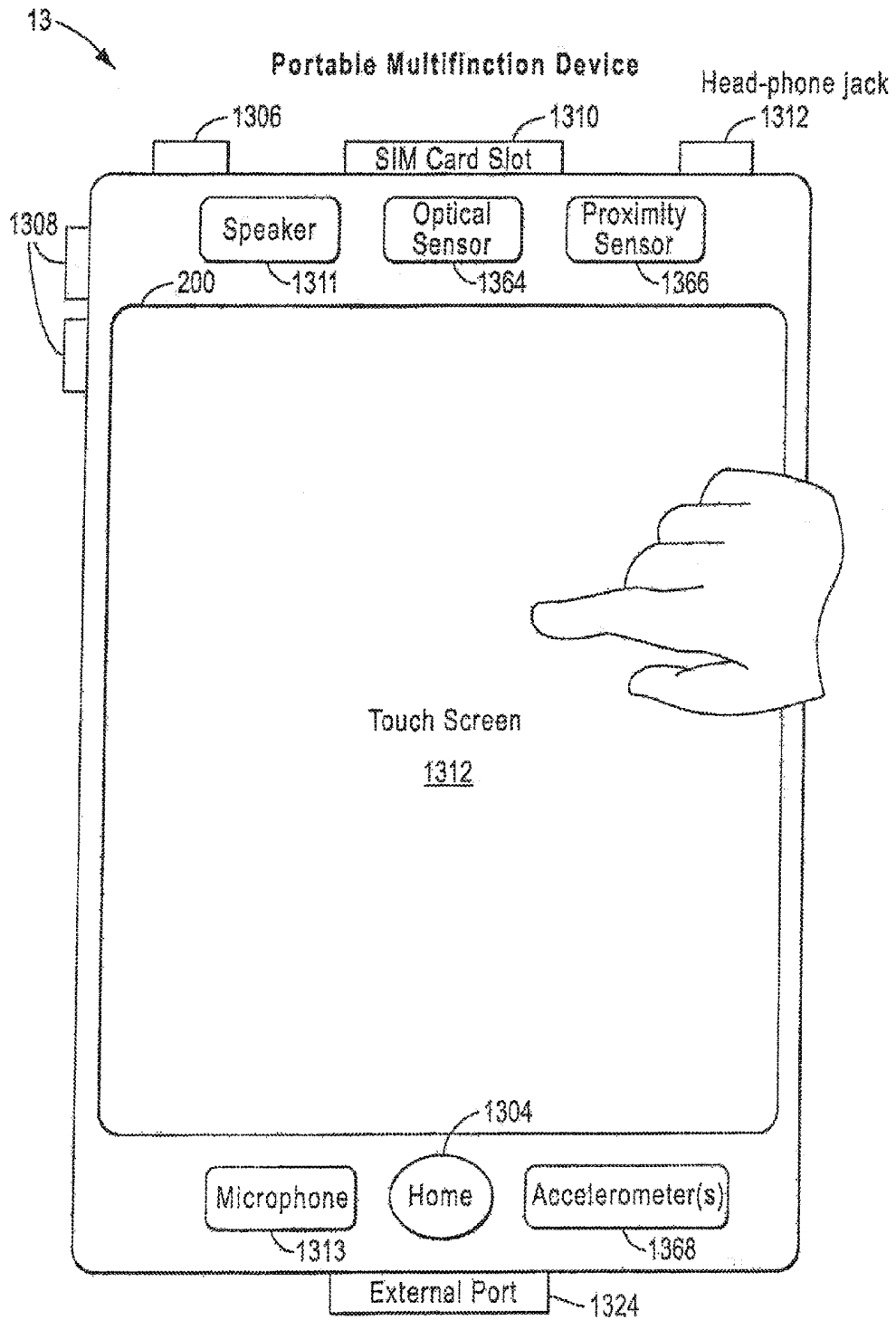

FIG. 41

Packaging Cross Section

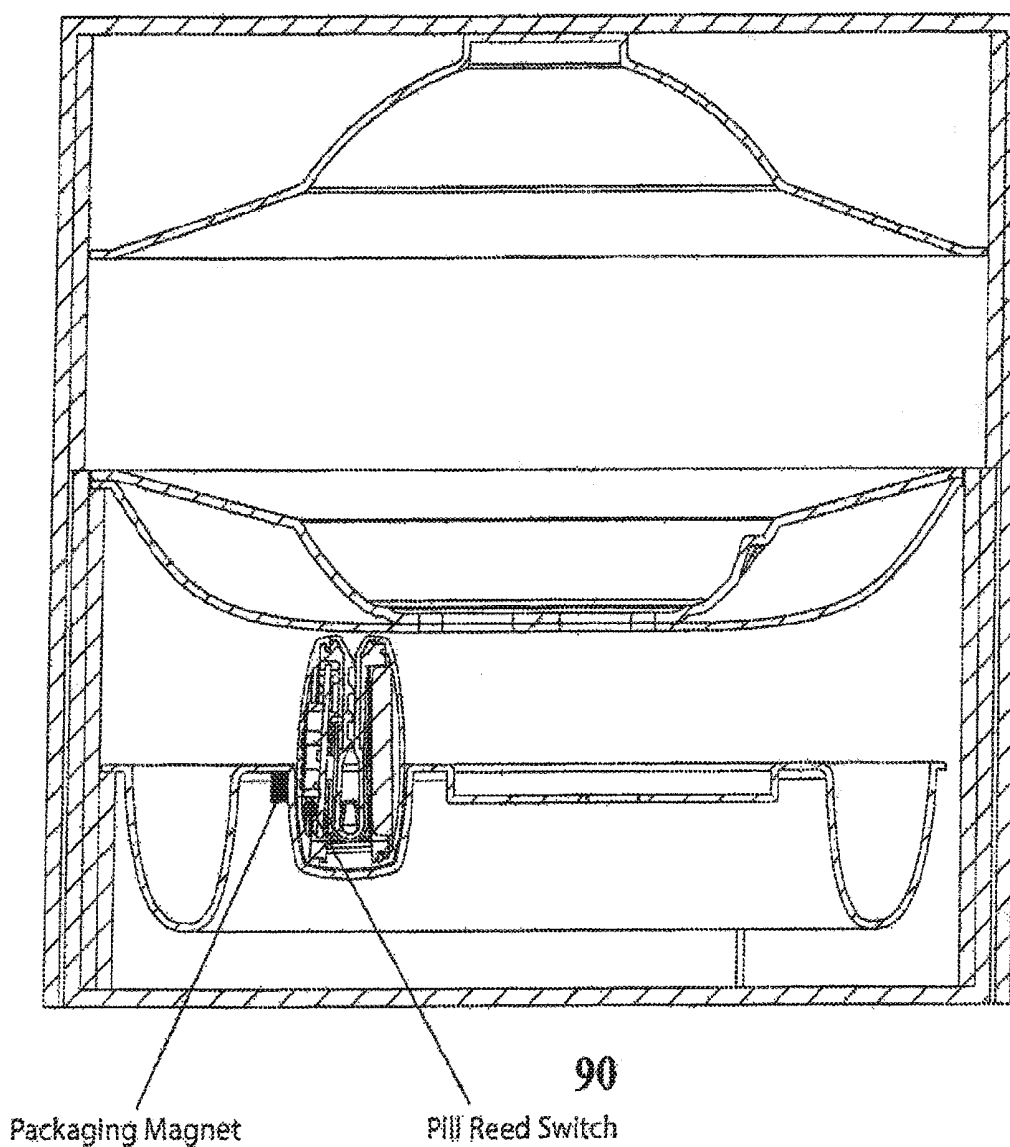

FIG. 42

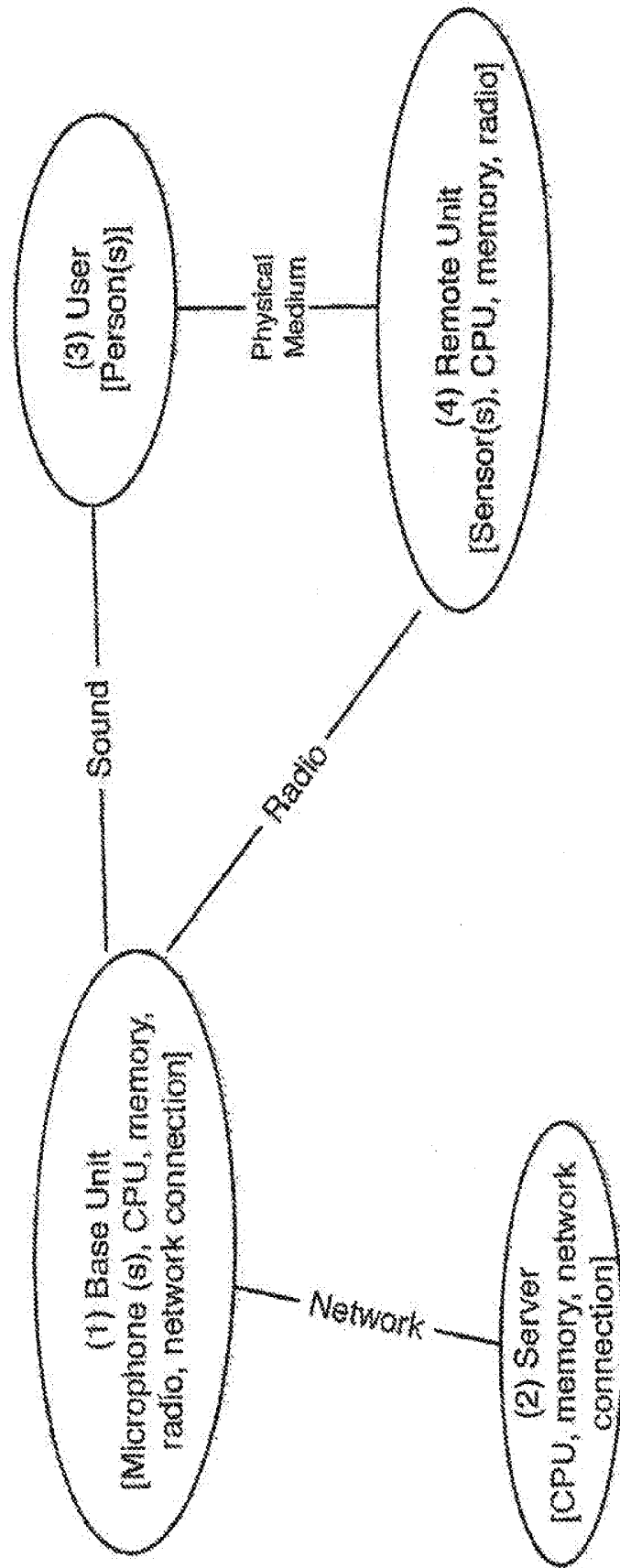

FIG. 43

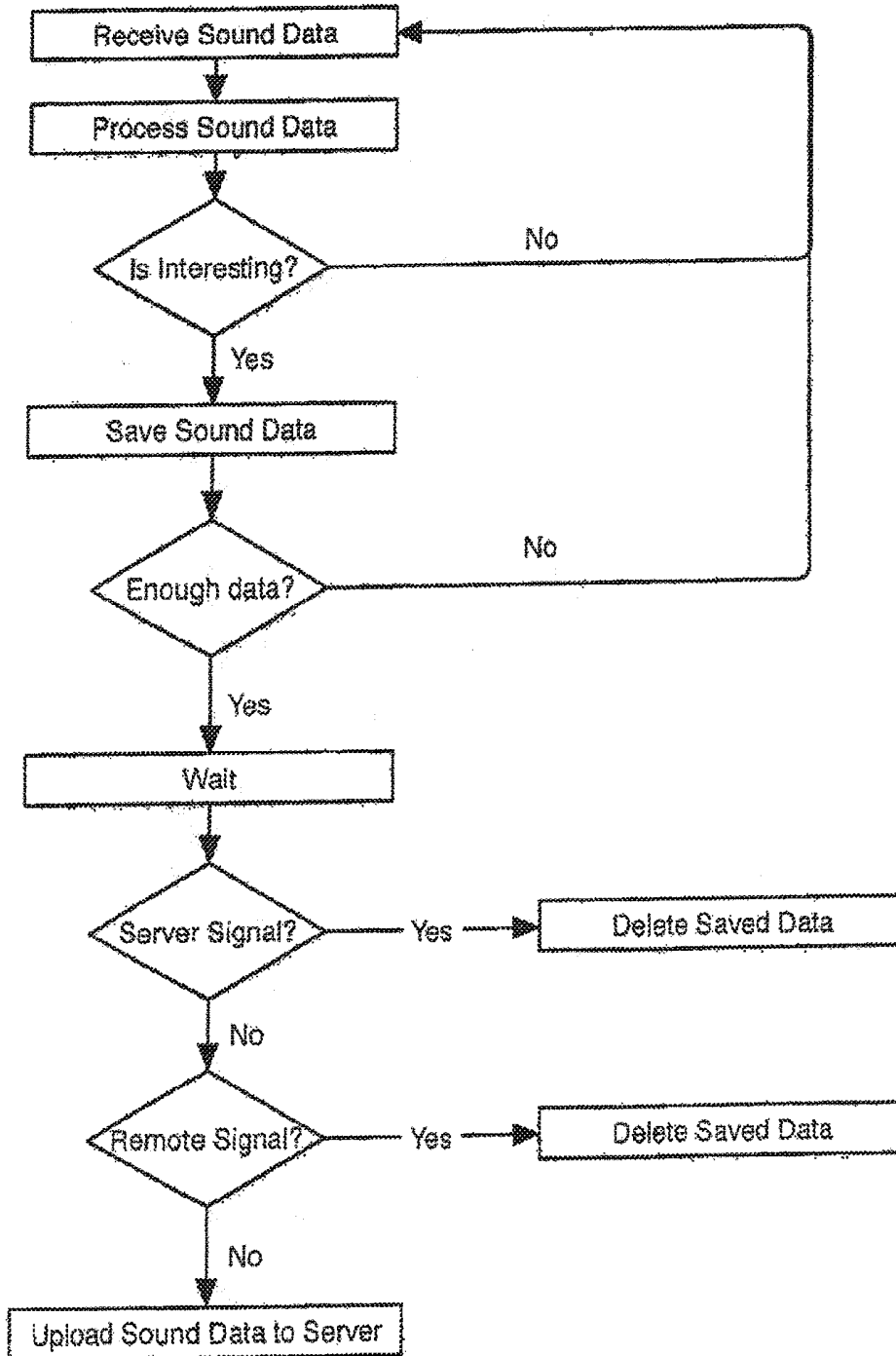

FIG. 44

**MONITORING DEVICE FOR SNORING****CROSS-REFERENCE TO RELATED APPLICATIONS**

**[0001]** This application claims the priority benefit of all of the following: This application also is related to and claims the benefit of which is a Continuation of U.S. application Ser. No. 13/923,543, filed Jun. 21, 2013, which is a Continuation of U.S. application Ser. No. 13/923,560, filed Jun. 21, 2013, now U.S. Pat. No. 8,803,366, issued Aug. 12, 2014, which is a Continuation of U.S. patent application Ser. No. 13/923,614, filed Jun. 21, 2013, now U.S. Pat. No. 8,850,421, issued Sep. 30, 2014, which is a Continuation of U.S. application Ser. No. 13/923,637, filed Jun. 21, 2013, now U.S. Pat. No. 8,810,430, issued Aug. 19, 2014, which is a Continuation of U.S. application Ser. No. 13/923,750, filed Jun. 21, 2013, which is a Continuation of U.S. application Ser. No. 13/923,809, filed Jun. 21, 2013, which is a Continuation of U.S. patent application Ser. No. 13/923,909, filed Jun. 21, 2013, which is a Continuation of U.S. application Ser. No. 13/923,937, filed Jun. 21, 2013, which is a Continuation-in-Part of U.S. application Ser. No. 13/955,777, filed Jul. 31, 2013, which is a Continuation of U.S. application Ser. No. 13/955,810, filed Jul. 31, 2013, which is a Continuation of U.S. application Ser. No. 13/955,845, filed Jul. 31, 2013, which is a Continuation of U.S. application Ser. No. 13/955,892, filed Jul. 31, 2013, which is a Continuation-in-Part of U.S. application Ser. No. 13/956,564, filed Aug. 1, 2013, which is a Continuation of U.S. application Ser. No. 13/956,674, filed Aug. 1, 2013, which is a Continuation of U.S. application Ser. No. 13/956,815, filed Aug. 1, 2013, which is a Continuation-in-Part of U.S. application Ser. No. 13/959,022, filed Aug. 5, 2013, which is a Continuation-in-Part of U.S. application Ser. No. 13/959,085, filed Aug. 5, 2013, which is a Continuation-in-Part of U.S. application Ser. No. 13/960,075, filed Aug. 6, 2013, which is a Continuation-in-Part of U.S. application Ser. No. 13/960,407, filed Aug. 6, 2013, which is a Continuation-in-Part of U.S. application Ser. No. 13/960,436, filed Aug. 6, 2013, which is a Continuation-in-Part of U.S. application Ser. No. 13/960,451, filed Aug. 6, 2013, which is a Continuation-in-Part of U.S. application Ser. No. 13/960,491, filed Aug. 6, 2013, which is a Continuation-in-Part of U.S. application Ser. No. 13/961,511, filed Aug. 7, 2013, which is a Continuation-in-Part of U.S. application Ser. No. 13/961,599, filed Aug. 7, 2013, which is a Continuation-in-Part of U.S. application Ser. No. 13/967,094, filed Aug. 14, 2013, which is Continuation of U.S. application Ser. No. 13/967,109, filed Aug. 14, 2013, which is a Continuation of U.S. application Ser. No. 13/967,120, filed Aug. 14, 2013, which is a Continuation of U.S. application Ser. No. 13/966,623, filed Aug. 14, 2013, which is a Continuation of U.S. application Ser. No. 13/966,641, filed Aug. 14, 2013, which is a Continuation-in-Part of U.S. application Ser. No. 14/023,876, filed Sep. 11, 2013, which is a Continuation-in-Part of U.S. application Ser. No. 14/036,111, filed Sep. 25, 2013, which is a Continuation of U.S. application Ser. No. 14/036,287, filed Sep. 25, 2013, which is a Continuation of U.S. application Ser. No. 14/036,382, filed Sep. 25, 2013, which is a Continuation-in-Part of U.S. application Ser. No. 14/037,536, filed Sep. 26, 2013, which is a Continuation of U.S. application Ser. No. 14/037,594, filed Sep. 26, 2013, which is a Continuation of U.S. application Ser. No. 14/037,643, filed Sep. 26, 2013, which is a Continuation of U.S. application Ser. No. 14/037,717, filed Sep. 26, 2013, which is a Continuation of U.S. application Ser. No.

14/037,747, filed Sep. 26, 2013, which is a Continuation of U.S. application Ser. No. 14/037,825, filed Sep. 26, 2013, which is a Continuation of U.S. application Ser. No. 14/037,870, filed Sep. 26, 2013, which is a Continuation of U.S. application Ser. No. 14/037,974, filed Sep. 26, 2013, which is a Continuation-in-Part of U.S. application Ser. No. 14/038,990, filed Sep. 27, 2013, which is a Continuation of U.S. patent application Ser. No. 14/039,145, filed Sep. 27, 2013, which is a Continuation of U.S. application Ser. No. 14/039,802, filed Sep. 27, 2013, which is a Continuation-in-Part of U.S. application Ser. No. 14/048,731, filed Oct. 8, 2013, which is a Continuation of U.S. application Ser. No. 14/049,690, filed Oct. 9, 2013, which is a Continuation of U.S. application Ser. No. 14/049,822, filed Oct. 9, 2013, which is a Continuation of U.S. application Ser. No. 14/051,093, filed Oct. 10, 2013, which is a Continuation of U.S. application Ser. No. 14/052,376, filed Oct. 11, 2013, which is a Continuation-in-Part of U.S. application Ser. No. 14/180,109, filed Feb. 13, 2014, which is a Continuation-in-Part of U.S. application Ser. No. 14/180,152, filed Feb. 13, 2014, and U.S. Provisional Patent Application No. 62/027,885, filed Jul. 23, 2014, which is a Continuation-in-Part U.S. application Ser. No. 14/495,332, filed Sep. 24, 2014, which is a Continuation U.S. application Ser. No. 14/495,656, filed Sep. 24, 2014, which is a Continuation-in-Part U.S. application Ser. No. 14/588,848, filed Jan. 2, 2015, which is a Continuation U.S. application Ser. No. 14/588,853, filed Jan. 2, 2015, which is a Continuation-in-Part U.S. application Ser. No. 14/604,566, filed Jan. 23, 2015 and which is a Continuation U.S. application Ser. No. 14/604,569, filed Jan. 23, 2015, U.S. Provisional Patent Application No. 62/118,384, filed Feb. 19, 2015, which is a Continuation-in-Part U.S. patent application Ser. No. 14/725,973, filed May 29, 2015, which is a Continuation-in-Part U.S. patent application Ser. No. 14/729,608, filed Jun. 6, 2015. All of the above applications are fully incorporated herein by reference.

**BACKGROUND**

**[0002]** 1. Field of the Invention

**[0003]** The present invention relates generally to systems and methods for monitoring sleep, and more particularly to monitoring a person's snoring.

**[0004]** 2. Description of the Related Art

**[0005]** Snoring is the vibration of respiratory structures and the resulting sound due to obstructed air movement during breathing while sleeping. In some cases, the sound may be soft, but in most cases, it can be loud and unpleasant. Snoring is a factor of sleep deprivation.

**[0006]** Snoring is known to cause sleep deprivation to snorers and those around them, as well as daytime drowsiness, irritability, lack of focus and decreased libido. It has also been suggested that it can cause significant psychological and social damage to sufferers. There is a positive correlation between loud snoring and risk of heart attack (about +34% chance) and stroke (about +67% chance).

**[0007]** Though snoring is often considered a minor affliction, snorers can sometimes suffer severe impairment of lifestyle. The between-subjects trial by Armstrong et al. discovered a statistically significant improvement in marital relations after snoring was surgically corrected.

**[0008]** Loud "snoring" has been associated with the development of carotid artery atherosclerosis. Vibration of the carotid artery with snoring also lends itself as a potential mechanism for atherosclerotic plaque rupture and conse-

quently ischemic stroke. Loud snoring can create turbulence in carotid artery blood flow. Generally speaking, increased turbulence irritates blood cells and has previously been implicated as a cause of atherosclerosis.

**[0009]** As many as half of adults sometimes snore. Snoring occurs when air flows past relaxed tissues in your throat, causing the tissues to vibrate as you breathe, which creates those irritating sounds.

**[0010]** Lifestyle changes, such as losing weight, avoiding alcohol close to bedtime or sleeping on your side, can help stop snoring.

**[0011]** In addition, medical devices and surgery are available that may reduce disruptive snoring. However, these aren't suitable or necessary for everyone who snores.

**[0012]** Snoring is often associated with a sleep disorder called obstructive sleep apnea (OSA). Not all snorers have OSA.

**[0013]** Apnea is a term for suspension of external breathing. During apnea, there is no movement of the muscles of inhalation and the volume of the lungs initially remains unchanged. Depending on how blocked the airways are (patency), there may or may not be a flow of gas between the lungs and the environment; gas exchange within the lungs and cellular respiration is not affected. Apnea can be voluntarily achieved, drug-induced (such as opiate toxicity or tryptamine toxicity), mechanically induced (for example, by strangulation or choking), or it can occur as a consequence of neurological disease or trauma. During sleep in patients who are suffering from sleep apnea, these events will occur up to 20-30 times per hour, every night.

**[0014]** Under normal conditions, humans cannot store much oxygen in the body. Prolonged apnea leads to severe lack of oxygen in the blood circulation. Permanent brain damage can occur after as little as three minutes and death will inevitably ensue after a few more minutes unless ventilation is restored. However, under special circumstances such as hypothermia, hyperbaric oxygenation, apneic oxygenation or extracorporeal membrane oxygenation, much longer periods of apnea may be tolerated without severe consequences.

**[0015]** Untrained humans cannot sustain voluntary apnea for more than one or two minutes. The reason for the time limit of voluntary apnea is that the rate of breathing and the volume of each breath are tightly regulated to maintain constant values of CO<sub>2</sub> tension and pH of the blood. In apnea, CO<sub>2</sub> is not removed through the lungs and accumulates in the blood. The consequent rise in CO<sub>2</sub> tension and drop in pH result in stimulation of the respiratory centre in the brain which eventually cannot be overcome voluntarily.

**[0016]** There is a need for improved systems and methods for monitoring snoring.

#### SUMMARY

**[0017]** An object of the present invention is to provide systems and method for to detect a person's level of snoring.

**[0018]** Another object of the present invention is to provide systems and methods that detects a vibration of respiratory structures.

**[0019]** Yet another object of the present invention is to detect vibration of respiratory structures that results in snoring sounds.

**[0020]** Still another object of the present invention is to provide systems and methods that detect vibration of respiratory structures that result in sound due to obstructed air movement during breathing while sleeping.

**[0021]** A further object of the present invention is to provide systems and methods to detect snoring sounds that are a factor of sleep deprivation.

**[0022]** Yet another object of the present invention is to provide systems and methods for detecting snoring sounds that are associated with sleep deprivation.

**[0023]** Another object of the present invention is to provide systems and methods for detecting snoring sounds that are indication of heart disease.

**[0024]** Still another object of the present invention is to provide systems and methods for detecting snoring sounds that are indicative of carotid artery atherosclerosis.

**[0025]** A further object of the present invention is to provide systems and methods for determining snoring that is indicative of turbulence in carotid artery blood flow.

**[0026]** Yet another object of the present invention is to systems and methods for determining snoring that is indicative of obstructive sleep apnea (OSA).

**[0027]** These and other objects of the present invention are achieved in a system for monitoring a person's snoring in a dwelling. A detection device is in communication with a user monitoring device. The detection device includes at least one motion/movement gesture sensing device configured to detect at least one of a person's motion, movement and gesture. A user monitoring device includes at least one element selected from: a proximity sensor; a temperature sensor; a humidity sensor; a particulate sensor; a light sensor; a microphone; one or more RF transmitters (BLE/ANT+WIFI); a memory; and one or more LED's. The detection device and user monitoring device detect a person's level of snoring.

**[0028]** In another embodiment of the present invention a method is provided for monitoring a person's snoring in a dwelling. A detection device is used that is in communication with a user monitoring device. The detection device including at least one motion/movement gesture sensing device configured to detect at least one of a person's motion, movement and gesture. A user monitoring device is provided that includes at least one element selected from: a proximity sensor; a temperature sensor; a humidity sensor; a particulate sensor; a light sensor; a microphone; one or more RF transmitters (BLE/ANT+WIFI); a memory; and one or more LED's. The detection device and the user monitoring device detect a person's level of snoring.

#### BRIEF DESCRIPTION OF THE DRAWINGS

**[0029]** FIG. 1(a) illustrates one embodiment of a user monitoring device of the present invention.

**[0030]** FIG. 1(b) illustrates one embodiment of a bottom board of the FIG. 1(a) user monitoring device with a temperature and humidity sensor.

**[0031]** FIG. 1(c) illustrates one embodiment of a top board of the FIG. 1(a) user monitoring device with an ambient light sensor, a proximity sensor, a speak module and a microphone.

**[0032]** FIG. 1(d) illustrates one embodiment of a middle board of the FIG. 1(a) user monitoring device.

**[0033]** FIG. 1(e) illustrates the communication between the cloud, client or mobile device, monitoring device 10 and motion detection device 42.

**[0034]** FIG. 2(a) is an exploded view of one embodiment of a motion/movement/gesture detective device of the present invention.

**[0035]** FIGS. 2(b) and 2(c) illustrate front and back surfaces of a board from the FIG. 2(a) motion/movement/gesture detection device with a reed switch and an accelerometer.

[0036] FIG. 3 is an image of an electronic device that contains an internal accelerometer;

[0037] FIG. 4 is a first embodiment of a tap and or shake detection system;

[0038] FIG. 5 is a second embodiment of a tap and or shake detection system that includes a subtraction circuit;

[0039] FIG. 6 is a flow chart that shows a method for detecting when a double tap and or shake has occurred; and

[0040] FIG. 7 is a graph that shows the derivative of acceleration with respect to time and includes thresholds for determining when a tap and or shake have occurred.

[0041] FIG. 8 is a block diagram of a microphone circuit according to the invention;

[0042] FIG. 9 is a cross-section view of an NMOS transistor;

[0043] FIG. 10 is a block diagram of an embodiment of a switch circuit according to the invention;

[0044] FIG. 11 is a block diagram of another embodiment of a switch circuit according to the invention;

[0045] FIG. 12(a) is an embodiment of a control logic that can be used with the FIG. 4 embodiment.

[0046] FIG. 12(b) is another embodiment of a control logic that can be used with the FIG. 4 embodiment.

[0047] FIG. 13 is a diagram that provides an overview of motion pattern classification and gesture creation and recognition.

[0048] FIG. 14 is a block diagram of an exemplary system configured to perform operations of motion pattern classification.

[0049] FIG. 15 is a diagram illustrating exemplary operations of dynamic filtering of motion example data.

[0050] FIG. 16 is a diagram illustrating exemplary dynamic time warp techniques used in distance calculating operations of motion pattern classification.

[0051] FIG. 17 is a diagram illustrating exemplary clustering techniques of motion pattern classification.

[0052] FIG. 18(a)-(c) are diagrams illustrating exemplary techniques of determining a sphere of influence of a motion pattern.

[0053] FIG. 19 is a flowchart illustrating an exemplary process of motion pattern classification.

[0054] FIG. 20 is a block diagram illustrating an exemplary system configured to perform operations of gesture creation and recognition.

[0055] FIG. 21(a)-(b) are diagrams illustrating exemplary techniques of matching motion sensor readings to a motion pattern.

[0056] FIG. 22 is a flowchart illustrating an exemplary process of pattern-based gesture creation and recognition.

[0057] FIG. 23 is a block diagram illustrating exemplary device architecture of a monitoring system implementing the features and operations of pattern-based gesture creation and recognition.

[0058] FIG. 24 is a block diagram of exemplary network operating environment for the monitoring systems implementing motion pattern classification and gesture creation and recognition techniques.

[0059] FIG. 25 is a block diagram of exemplary system architecture for implementing the features and operations of motion pattern classification and gesture creation and recognition.

[0060] FIG. 26 illustrates a functional block diagram of a proximity sensor in an embodiment of the invention.

[0061] FIG. 27(a) illustrates a schematic diagram of the proximity sensing unit sensing when the LED is active and emits lights under the condition that no object is close by to the proximity sensor of the electronic apparatus.

[0062] FIG. 27(b) illustrates a schematic diagram of the proximity sensing unit sensing when the LED is inactive under the condition that no object is close by to the proximity sensor of the electronic apparatus.

[0063] FIG. 27(c) illustrates a schematic diagram of the proximity sensing unit sensing when the LED is active and emits lights under the condition that an object is located in the detection range of the proximity sensor.

[0064] FIG. 27(d) illustrates a schematic diagram of the proximity sensing unit sensing when the LED is inactive under the condition that an object is located in the detection range of the proximity sensor.

[0065] FIG. 27(e) illustrates a schematic diagram of the proximity sensing unit sensing when the LED is active and emits lights under the condition that an object is located out of the detection range of the proximity sensor.

[0066] FIG. 27(f) illustrates a schematic diagram of the proximity sensing unit sensing when the LED is inactive under the condition that an object is located out of the detection range of the proximity sensor.

[0067] FIG. 28 illustrates a flowchart of the proximity sensor operating method in another embodiment of the invention.

[0068] FIGS. 29(a) and (b) illustrate flowcharts of the proximity sensor operating method in another embodiment of the invention.

[0069] FIG. 30 is a schematic view showing a configuration of a particle detection apparatus of a first embodiment according to the present invention.

[0070] FIG. 31 is a time chart showing the timing of the operation of the light emitting-element and the exposure of the image sensor.

[0071] FIGS. 32(a) and (b) are views showing schematized image information of a binarized particle image.

[0072] FIGS. 33(a) and (b) are views showing temporal changes of a binarized image signal.

[0073] FIGS. 34(a) and (b) are views showing a modified embodiment of a photodetector, which indicate particle detection at different times for each view. Each view shows a positional relation between the photodetector and the particle at left side and output values at right side.

[0074] FIG. 35 is a schematic view showing a configuration of a particle detection apparatus in one embodiment.

[0075] FIG. 36 is a block diagram representative of an embodiment of the present invention.

[0076] FIG. 37 is a flow chart showing the method for compensated temperature determination in accordance with an embodiment of the invention.

[0077] FIGS. 38(a)-(e) illustrate one embodiment of a Cloud Infrastructure that can be used with the present invention.

[0078] FIGS. 39-41 illustrate one embodiment of a mobile device that can be used with the present invention.

[0079] FIG. 42 illustrates one embodiment of a packaging for the motion detection device.

[0080] FIGS. 43 and 44 illustrate one embodiment of the present invention where recording the movement of the person by the motion detection device is not always preserved, and is halted in response to the sounds received from the room where the person is located.

## DETAILED DESCRIPTION

**[0081]** As used herein, the term engine refers to software, firmware, hardware, or other component that can be used to effectuate a purpose. The engine will typically include software instructions that are stored in non-volatile memory (also referred to as secondary memory) and a processor with instructions to execute the software. When the software instructions are executed, at least a subset of the software instructions can be loaded into memory (also referred to as primary memory) by a processor. The processor then executes the software instructions in memory. The processor may be a shared processor, a dedicated processor, or a combination of shared or dedicated processors. A typical program will include calls to hardware components (such as I/O devices), which typically requires the execution of drivers. The drivers may or may not be considered part of the engine, but the distinction is not critical.

**[0082]** As used herein, the term database is used broadly to include any known or convenient means for storing data, whether centralized or distributed, relational or otherwise.

**[0083]** As used herein a mobile device includes, but is not limited to, a cell phone, such as Apple's iPhone®, other portable electronic devices, such as Apple's iPod Touches®, Apple's iPads®, and mobile devices based on Google's Android® operating system, and any other portable electronic device that includes software, firmware, hardware, or a combination thereof that is capable of at least receiving a wireless signal, decoding if needed, and exchanging information with a server. Typical components of mobile device may include but are not limited to persistent memories like flash ROM, random access memory like SRAM, a camera, a battery, LCD driver, a display, a cellular antenna, a speaker, a BLUETOOTH® circuit, and WIFI circuitry, where the persistent memory may contain programs, applications, and/or an operating system for the mobile device. For purposes of this application, a mobile device is also defined to include a fob, and its equivalents.

**[0084]** As used herein, the term "computer" is a general purpose device that can be programmed to carry out a finite set of arithmetic or logical operations. Since a sequence of operations can be readily changed, the computer can solve more than one kind of problem. A computer can include of at least one processing element, typically a central processing unit (CPU) and some form of memory. The processing element carries out arithmetic and logic operations, and a sequencing and control unit that can change the order of operations based on stored information. Peripheral devices allow information to be retrieved from an external source, and the result of operations saved and retrieved. Computer also includes a graphic display medium.

**[0085]** As used herein, the term "internet" is a global system of interconnected computer networks that use the standard Network Systems protocol suite (TCP/IP) to serve billions of users worldwide. It is a network of networks that consists of millions of private, public, academic, business, and government networks, of local to global scope, that are linked by a broad array of electronic, wireless and optical networking technologies. The internet carries an extensive range of information resources and services, such as the inter-linked hypertext documents of the World Wide Web (WWW) and the infrastructure to support email. The communications infrastructure of the internet consists of its hardware components and a system of software layers that control various aspects of the architecture.

**[0086]** As used herein, the term "extranet" is a computer network that allows controlled access from the outside. An extranet can be an extension of an organization's intranet that is extended to users outside the organization in isolation from all other internet users. An extranet can be an intranet mapped onto the public internet or some other transmission system not accessible to the general public, but managed by more than one company's administrator(s). Examples of extranet-style networks include but are not limited to:

**[0087]** LANs or WANs belonging to multiple organizations and interconnected and accessed using remote dial-up

**[0088]** LANs or WANs belonging to multiple organizations and interconnected and accessed using dedicated lines

**[0089]** Virtual private network (VPN) that is comprised of LANs or WANs belonging to multiple organizations, and that extends usage to remote users using special "tunneling" software that creates a secure, usually encrypted network connection over public lines, sometimes via an ISP.

**[0090]** As used herein, the term "Intranet" is a network that is owned by a single organization that controls its security policies and network management. Examples of intranets include but are not limited to:

**[0091]** A LAN

**[0092]** A Wide-area network (WAN) that is comprised of a LAN that extends usage to remote employees with dial-up access

**[0093]** A WAN that is comprised of interconnected LANs using dedicated communication lines

**[0094]** A Virtual private network (VPN) that is comprised of a LAN or WAN that extends usage to remote employees or networks using special "tunneling" software that creates a secure, usually encrypted connection over public lines, sometimes via an Internet Service Provider (ISP).

**[0095]** For purposes of the present invention, the Internet, extranets and intranets collectively are referred to as ("Network Systems").

**[0096]** As used herein "Cloud Application" refers to cloud application services or "software as a service" (SaaS) which deliver software over the Network Systems eliminating the need to install and run the application on a device.

**[0097]** As used herein "Cloud Platform" refers to a cloud platform services or "platform as a service" (PaaS) which deliver a computing platform and/or solution stack as a service, and facilitates the deployment of applications without the cost and complexity of obtaining and managing the underlying hardware and software layers.

**[0098]** As used herein "Cloud System" refers to cloud infrastructure services or "infrastructure as a service" (IAAS) which deliver computer infrastructure as a service with raw block storage and networking.

**[0099]** As used herein "Server" refers to server layers that consist of computer hardware and/or software products specifically designed for the delivery of cloud services.

**[0100]** As used herein, the term "user monitoring" includes: (i) cardiac monitoring, which generally refers to continuous electrocardiography with assessment of the user's condition relative to their cardiac rhythm. A small monitor worn by an ambulatory user for this purpose is known as a Holter monitor. Cardiac monitoring can also involve cardiac output monitoring via an invasive Swan-Ganz catheter (ii) Hemodynamic monitoring, which monitors the blood pressure and blood flow within the circulatory system. Blood pressure can be measured either invasively through an inserted blood pressure transducer assembly, or noninva-

sively with an inflatable blood pressure cuff. (iii) Respiratory monitoring, such as: pulse oximetry which involves measurement of the saturated percentage of oxygen in the blood, referred to as SpO<sub>2</sub>, and measured by an infrared finger cuff, capnography, which involves CO<sub>2</sub> measurements, referred to as EtCO<sub>2</sub> or end-tidal carbon dioxide concentration. The respiratory rate monitored as such is called AWRR or airway respiratory rate. (iv) respiratory rate monitoring through a thoracic transducer belt, an ECG channel or via capnography, (v) Neurological monitoring, such as of intracranial pressure. Special user monitors can incorporate the monitoring of brain waves electroencephalography, gas anesthetic concentrations, bispectral index (BIS), and the like, (vi) blood glucose monitoring using glucose sensors. (vii) childbirth monitoring with sensors that monitor various aspects of childbirth. (viii) body temperature monitoring which in one embodiment is through an adhesive pad containing a thermoelectric transducer. (ix) stress monitoring that can utilize sensors to provide warnings when stress levels signs are rising before a human can notice it and provide alerts and suggestions. (x) epilepsy monitoring. (xi) toxicity monitoring, (xii) general lifestyle parameters, (xiii) sleep, including but not limited to: sleep patterns, type of sleep, sleep disorders, movement during sleep, waking up, falling asleep, problems with sleep, habits during, before and after sleep, time of sleep, length sleep in terms of the amount of time for each sleep, body activities during sleep, brain patterns during sleep and the like (xiv) body gesture, movement and motion (xv) body habits, (xvi) and the like.

**[0101]** In various embodiments, the present invention provides systems and methods for monitoring and reporting human physiological information, life activities data of the individual, generate data indicative of one or more contextual parameters of the individual, monitor the degree to which an individual has followed a routine and the like, along with providing feedback to the individual.

**[0102]** In certain embodiments, the suggested routine may include a plurality of categories, including but not limited to, body movement/motion/gesture, habits, health parameters, activity level, mind centering, sleep, daily activities, exercise and the like.

**[0103]** In general, according to the present invention, data relating to any or all of the above is collected and transmitted, either subsequently or in real-time, to a site, the cloud and the like that can be remote from the individual, where it is analyzed, stored, utilized, and the like via Network System. Contextual parameters as used herein means parameters relating any of the above, including the environment, surroundings and location of the individual, air quality, sound quality, ambient temperature, global positioning and the like, as well as anything relative to the categories mentioned above.

**[0104]** In various embodiments, the present invention provides a user monitoring device 10. As illustrated in FIG. 1(a) monitoring device 10 can include an outer shell 12, a protective cover 14, a top circuit board 16, a microphone 18, a speaker module 20, a circuit board support structure 22, a protective quadrant 24, a middle circuit board 26, a particular air duct 28, a particulate sensor 30, a center support structure 32, a light emitter 34, a bottom circuit board 36, a temperature sensor 38, FIG. 1(b) and a base 40.

**[0105]** FIG. 1(e) illustrates the communication between the cloud, client or mobile device, monitoring device 10 and motion detection device 42.

**[0106]** FIG. 2(a) illustrates one embodiment of a detection device, (hereafter motion/movement/gesture detective device 42). In one embodiment motion/movement/gesture/ detection device 42 includes a front shell 44, an emitter gasket 46, a circuit board 48, a front support structure 50, spring steel 52, an elastomeric foot 54, a rear support structure 56, a battery terminal 58, a terminal insulting film 60, a coin cell battery 62 and a back shell 64.

**[0107]** The monitor device 10 can include a plurality of ports, generally denoted as 65, that: (i) allow light to be transmitted from an interior of the monitor device to the user for visual feedback, (ii) a port 65 for the proximity sensor 68, and (iii) one or more ports 65 that allows for the introduction of air. In one embodiment the ports 65 for the introduction for air are located at a bottom portion of monitor device 10.

**[0108]** As illustrated in FIGS. 1(b), 1(c) and 1(d) in one embodiment the monitor device 10 includes four different printed circuit boards (PCBs). In one embodiment a top PCB includes an ambient light sensor 66, a proximity sensor 70, a microphone 72 and speaker module 74. These are utilized for user interaction and also to pick up the most data. There are no sensors on the middle PCB. In one embodiment the bottom PCB has one temperature/humidity sensor 76 as the USB for wall charging. A battery pack is optional. Air ducting inside the monitor device 10 is provided to direct particulates, including but not limited to dust, towards the particulate sensor 30.

**[0109]** In one embodiment the monitor device 10 includes one or more of a housing with a plurality of ports 65, and one or more of the following elements: proximity sensor; temperature sensor/humidity sensor; particulate sensor 30; light sensor 66; microphone 70; speaker 74; two RF transmitters 76 (BLE/ANT+WIFI); a memory card 78; and LED's 80.

**[0110]** In one embodiment the monitor device 10 lights up to indicate either that the user is alarmed, that something is wrong, or if everything is ok. This provides quick feedback to the user.

**[0111]** In one embodiment, illustrated in FIGS. 2(b) and 2(c) the motion/movement/gesture detection device 42 is provided that is located external to a monitor device 10 that includes one or more sensors. In one embodiment the motion/movement/gesture detection device 42 includes: an RF transmitter (BLE/ANT) 82, motion/movement/gesture detection detector 84; a central processing unit (CPU) 86, an RGB LED 88 and a reed switch 90. As a non-limiting example, motion/movement/gesture detection device 42 is attached to a pillow, bed cover, bed sheet, bedspread, and the like, in close enough proximity to the person being monitored that monitor device can detect signals from motion/movement/gesture detection device 42, and can be in the same room or a different room where the monitored person is.

**[0112]** In one embodiment the motion/movement/gesture detection device 42 is configured to detect motion, movement and the like, of a person over a certain threshold. When motion is detected, it wakes up the CPU 86 which processes the data emitted by the motion/movement/gesture detection device 42. The CPU 86 can optionally encrypt the data. The CPU 86 can broadcast the data collected through the RF transmitter.

**[0113]** In one embodiment the motion/movement/gesture detection device 42 is a position sensing device that is an accelerometer 84 which detects motion, movement/gesture and the like, of a person. As a non-limiting example, the accelerometer 84 provides a voltage output that is propor-

tional to a detected acceleration. Suitable accelerometers are disclosed in, U.S. Pat. No. 8,347,720, U.S. Pat. No. 8,544,326, U.S. Pat. No. 8,542,189, U.S. Pat. No. 8,522,596, EP0486657B1, EP 2428774 A1, incorporated herein by reference. In one embodiment the accelerometer reports X, Y, and X axis information.

**[0114]** In certain embodiments other motion/movement gesture sensing devices **42** can be utilized including but not limited to: position sensing devices including but not limited to, optical encoders, magnetic encoders, mechanical encoders, Hall Effect sensors, potentiometers, contacts with ticks and the like.

**[0115]** The motion/movement/gesture detection device **84** provides one or more outputs. In one embodiment the output is a single value that detects the most interesting motion of the person within a defined time period. As a non-limiting example, this can be 60 seconds. The interesting motion is defined as that which provides the most information relative to movement/motion/gesture, and the like, of the person, that is different from a normal pattern of movement/motion/gesture and the like, that are not common occurrences of the person's movement/motion and gesture.

**[0116]** The motion/movement/gesture detection device **42** communicates with the monitor device **10** over the ANT protocol. The data collected by the motion/movement/gesture detection device **42** can be encrypted before being broadcasted. Any motion/movement/gesture detection device can **42** safely connect to any monitor device to transmit data.

**[0117]** In one embodiment the monitor device **10** can also communicate with the motion/movement/gesture detection device **42** to exchange configuration information.

**[0118]** The monitor device **10** communicates with a Cloud System **110**. The monitor device uploads data to the Cloud System at some interval controlled by the Cloud System **110**. In one embodiment the data uploaded contains information collected from all sensors that are included in the monitor device, including but not limited to, temperature, humidity, particulates, sound, light, proximity, motion/movement/gesture detection device data, as well as system information including the monitor device's unique identifier (mac address), remaining storage capacity, system logs, and the like. To verify integrity and authenticity of the data, a cryptographic hash is included in the data.

**[0119]** In one embodiment monitor device receives commands and data from the Cloud System after each upload. As non-limiting examples the commands can include but are not limited to: light commands (color, pattern, duration); sound commands (sound, pattern, duration); personalized data which again as a non-limiting example can include ideal temperature, humidity, particulate level and the like; and custom configuration for algorithms running on monitor device.

**[0120]** Values generated by the monitor device elements, e.g., sensors and other elements in the monitor device, are collected over a selected time period. As a non-limiting example, this time period can be one minute. Data is also accumulated from the motion/movement/gesture detection device. The combination of the motion/movement/gesture detection device and the monitor device data and the combination of the two is then synchronized at a server. As a non-limiting example, the server can be at the Cloud System **110**. Following the synchronization the server communicates instructions to the monitor device.

**[0121]** In one embodiment a person's mobile device communicates with monitor device over Bluetooth Low Energy

(BLE). As non-limiting examples, the mobile device can send command information directed to one or more of: securely sharing Wife credentials; activating sensors, including but not limited to light, sound and the like; exchanges system state information; communicates maintenance operations; and the like.

**[0122]** In one embodiment mobile devices communicate securely to the Cloud System through mobile applications. As non-limiting examples these applications provide the ability to create an account, authenticate, access the data uploaded by monitor device, and perform other actions (set alarm, and the like) that are not typical of the environment where the client is.

**[0123]** In one embodiment the Cloud System pushes information to mobile devices when notification is needed.

**[0124]** In one embodiment monitor device performs audio classification and similarity detection to identify sounds and extra sound characteristics on the most interesting sounds that are not common occurrences.

**[0125]** In one embodiment algorithms are used to detect start, end, duration and quality of sleep activity. In one embodiment additional algorithms are used to detect motion events caused by another motion/movement/gesture detection device user sharing a same bed.

**[0126]** In one embodiment the Cloud System includes three subsystems which can communicate asynchronously. This can include one or more of a: (i) synchronization system that is responsible for receiving data uploaded by monitor device, verifying authenticity and integrity of the data uploaded, sending commands to monitor device **10**. The data received is then queued for processing; (ii) processing service which is responsible for data analysis, persistence and transformation, visualization; and a presentation service for presenting data to the authenticated users.

**[0127]** In one embodiment the motion/movement/gesture detection device **42** analyzes motion data collected in real-time by an accelerometer. An algorithm processes the data and extract the most statistically interesting readings. At a predefined interval, the data collected is broadcasted to a monitor device.

**[0128]** In one embodiment the motion/movement/gesture detection device **42** is a three axis accelerometer. As a non-limiting example, the three axis accelerometer is modeled as

$$zk = ak + gk + bk + vA; k$$

**[0129]** Where  $zk$  is the sensor output at time  $k$ ,  $ak$  corresponds to the accelerations due to linear and rotational movement,  $bk$  is the  $o\_set$  of the sensor, and  $vA; k$  is the observed noise.

#### Accelerometer

**[0130]** In one embodiment of the present invention, illustrated in FIG. 3, the motion/movement/gesture detection device **42** includes an accelerometer **110** generally mounted on a circuit board **130** within the motion/movement/gesture detection device **42**. The accelerometer **110** may be a single axis accelerometer (x axis), a dual axis accelerometer (x, y axes) or a tri-axis accelerometer (x, y, z axes). The electronic device may have multiple accelerometers that each measure 1, 2 or 3 axes of acceleration. The accelerometer **110** continuously measures acceleration producing a temporal acceleration signal. The temporal acceleration signal may contain more than one separate signal. For example, the temporal acceleration signal may include 3 separate acceleration sig-

nals, i.e. one for each axis. In certain embodiments, the accelerometer includes circuitry to determine if a tap and or shake have occurred by taking the derivative of the acceleration signal. In some embodiments, the accelerometer includes a computation module for comparing the derivative values to a threshold to determine if a tap and or shake have occurred. In other embodiments, the accelerometer outputs a temporal acceleration signal and the computation module takes the first derivative of the acceleration signal produce a plurality of derivative values. The computation module can then compare the first derivative values to a predetermined threshold value that is stored in a memory of the computation module to determine if a tap and or shake have occurred.

[0131] FIG. 4 shows a first embodiment of the tap and or shake detection system 200 that includes a computation module 220 and the accelerometer 210. The accelerometer output signal is received by a computation module 220 that is electrically coupled to the accelerometer 210 and that is running (executing/interpreting) software code. It should be understood by one of ordinary skill in the art that the software code could be implemented in hardware, for example as an ASIC chip or in an FPGA or a combination of hardware and software code. The computation module running the software receives as input the data from the accelerometer and takes the derivative of the signal. For example, the accelerometer may produce digital output values for a given axis that are sampled at a predetermined rate. The derivative of the acceleration values or “jerk” can be determined by subtracting the N and N-1 sampled values. The acceleration values may be stored in memory 230A, 230B either internal to or external to the computation module 220 during the calculation of the derivative of acceleration.

[0132] Other methods/algorithms may also be used for determining the derivative of the acceleration. The jerk value can then be compared to a threshold. The threshold can be fixed or user-adjustable. If the jerk value exceeds the threshold then a tap and or shake is detected. In some embodiments, two threshold values may be present: a first threshold value for tap and or shakes about the measured axis in a positive direction and a second threshold for tap and or shakes about the axis in a negative direction. It should be recognized by one of ordinary skill in the art that the absolute value of the accelerometer output values could be taken and a single threshold could be employed for accelerations in both a positive and negative direction along an axis. When a tap and or shake have been detected, the computation unit can then forward a signal or data indicative of a tap and or shake as an input for another application/process. The application/process may use the detection of a tap and or shake as an input signal to perform an operation. For example, a tap and or shake may indicate that a device should be activated or deactivated (on/off). Thus, the tap and or shake detection input causes a program operating on the device to take a specific action. Other uses for tap and or shake detection include causing a cellular telephone to stop audible ringing when a tap and or shake is detected or causing a recording device to begin recording. These examples should not be viewed as limiting the scope of the invention and are exemplary only.

[0133] FIG. 5 shows a second embodiment of the tap and or shake detection system that uses a buffer for storing a temporal acceleration value along with a subtraction circuit. This embodiment can be used to retrofit an electronic device that already has a tap and or shake detection algorithm without needing to alter the algorithm. For purposes of this discus-

sion, it will be assumed that the high bandwidth acceleration data is for a single axis. The acceleration data may include data from a multi-axis accelerometer.

[0134] The circuit shows high bandwidth data 300 from an accelerometer unit being used as input to the tap and or shake detection system 305. The high-bandwidth data 300 is fed to a multiplexor 350 and also to a low pass filter 310. The high bandwidth data 300 from the accelerometer is low pass filtered in order to reduce the data rate, so that the data rate will be compatible with the other circuit elements of the tap and or shake detection system 305. Therefore, the low pass filter is an optional circuit element if the data rate of the accelerometer is compatible with the other circuit elements. Once the acceleration data is filtered, the sampled data (N-1) is stored in a register 320. The next sampled data value (N) is passed to the subtraction circuit 330 along with the sampled value that is stored in the register (N-1) 320. As the N-1 data is moved to the subtraction circuit 330, the N data value replaces the N-1 value in the register 320. Not shown in the figure is a clock circuit that provides timing signals to the low pass filter 310, the register 320, and the subtraction circuit 330. The clock circuit determines the rate at which data is sampled and passed through the circuit elements. If the accelerometer samples at a different rate than the clock rate, the low pass filter can be used to make the accelerometer's output data compatible with the clock rate. The subtraction circuit 330 subtracts the N-1 value from the N value and outputs the resultant value. The resultant value is passed to the tap and or shakes detection circuit 340 when the jerk select command to the multiplexor is active. The acceleration data may also be passed directly to the tap and or shake detection circuit when there is no jerk select command. In certain embodiments of the invention, the accelerometer unit along with the register, subtraction circuit, and multiplexor are contained within the accelerometer package.

[0135] The tap and or shake detection circuit 340 may be a computation module with associated memory that stores the threshold jerk values within the memory. The tap and or shake detection circuit may be either internal to the accelerometer packaging or external to the accelerometer packaging. For example, in a cell phone that includes one or more processors, a processor can implement the functions of a computation module. The computation module 340 compares the resultant jerk value to the one or more threshold jerk values. In one embodiment, there is a positive and a negative threshold jerk value. If the resultant value exceeds the threshold for a tap and or shake in a positive direction or is below the threshold for a tap and or shake in a negative direction, the tap and or shake detection circuit indicates that a tap and or shake has occurred. The tap and or shake identification can be used as a signal to cause an action to be taken in a process or application. For example, if the electronic device is a cell phone and a tap and or shake are detected, the tap and or shake may cause the cell phone to mute its ringer.

[0136] In other embodiments, the computation module determines if a tap and or shake occurs and then can store this information along with timing information. When a second tap and or shake occurs, the computation module can compare the time between tap and or shakes to determine if a double tap and or shake has occurred. Thus, a temporal threshold between tap and or shakes would be indicative of a double tap and or shake. This determination could be similar to the double tap and or shake algorithms that are used for computer input devices. For example, a double click of a

computer mouse is often required to cause execution of a certain routine within a computer program. Thus, the double tap and or shake could be used in a similar fashion.

[0137] FIG. 6 shows a flow chart for determining if a double tap and or shake have occurred. The system is initially at idle and the acceleration derivative values (jerk values) are below the threshold value 400. Each jerk value is compared to a threshold value 410. When the threshold value is exceeded, a first click or tap and or shake are identified. The system waits either a predetermined length of time or determines when the jerk value goes below the threshold to signify that the first tap and or shake has ended 420. A timer then starts and measures the time from the end of the first tap and or shake and the system waits for a second tap and or shake 430. The system checks each jerk value to see if the jerk value has exceeded the threshold 440. If the jerk value does not exceed the threshold the system waits. When the threshold is exceeded, the system determines the time between tap and or shakes and compares the time between tap and or shakes to a double tap and or shake limit 440. If the time between tap and or shakes is less than the double tap and or shake time limit, a double tap and or shake is recognized 450. If a double tap and or shake is not recognized, the present tap and or shake becomes the first tap and or shake and the system waits for the end of the first tap and or shake. When a second tap and or shake occurs, an identifier of the second tap and or shake i.e. a data signal, flag or memory location is changed and this information may be provided as input to a process or program. Additionally, when a double tap and or shake have been monitored, the methodology loops back to the beginning and waits for a new tap and or shake.

[0138] FIG. 7 shows a graph of the derivative of acceleration data ("jerk") with respect to time for the same series of accelerations as shown in FIG. 3. FIG. 5 provides a more accurate indication of tap and or shakes. FIG. 3 shows both false positive tap and or shake readings along with true negative readings. Thus, the acceleration measurement will not register some tap and or shakes and will also cause tap and or shakes to be registered when no tap and or shake was present. False positive readings occur, for example, when a user has a cell phone in his pocket and keys or other objects strike the cell phone due to movement of the user. These false readings are caused mainly because of the noise floor. By taking the derivative of the acceleration signal, the noise floor is lowered and the tap and or shake signals become more pronounced. Thus, false positive identifications of tap and or shakes are reduced with a lower noise floor. By requiring double tap and or shakes the number of false positives is reduced even further.

#### Audio

[0139] FIG. 8 is a block diagram of a microphone circuit 500 in one embodiment. In one embodiment, the microphone circuit 500 includes a transducer 502, a biasing resistor 504, a pre-amplifier 506, a switch circuit 508, and control logic 510. The transducer 502 is coupled between a ground VGND and a node 520. The transducer 502 converts a sound into a voltage signal and outputs the voltage signal to the node 520. The biasing resistor 504 is coupled between the node 520 and the ground VGND and biases the node 520 with a DC voltage level of the ground voltage VGND. The pre-amplifier 506 receives the voltage signal output by the transducer 502 at the

node 520 and amplifies the voltage signal to obtain an output signal  $V_o$  at a node 522. In one embodiment, the pre-amplifier 506 is a unity gain buffer.

[0140] The pre-amplifier 506 requires power supplied by a biasing voltage for amplifying the voltage signal output by the transducer 502. The switch circuit 508 is coupled between the node 520 and the ground voltage VGND. The switch circuit 508 therefore controls whether the voltage of the node 520 is set to the ground voltage VGND. When the microphone circuit 500 is reset, the control logic 510 enables a resetting signal VR to switch on the switch circuit 508, and the node 520 is therefore directly coupled to the ground VGND. When the microphone circuit 500 is reset, a biasing voltage VDD is applied to the pre-amplifier 506, and the voltage at the node 520 tends to have a temporary voltage increase. However, because the switch circuit 508 couples the node 520 the ground VGND, the voltage of the node 520 is kept at the ground voltage VGND and prevented from increasing, thus avoiding generation of the popping noise during the reset period. After a voltage status of the pre-amplifier 506 is stable at time T1, the control logic 510 switches off the switch circuit 508. The node 520 is therefore decoupled from the ground VGND, allowing the voltage signal generated by the transducer 502 to be passed to the pre-amplifier 506. Thus, the switch circuit 508 clamps the voltage of the node 520 to the ground voltage during the reset period, in which the biasing voltage VDD is just applied to the pre-amplifier 506.

[0141] Referring to FIG. 12(a), an embodiment of control logic 510 is shown. In the embodiment, the control logic 510 is a power-on-reset circuit 800. The power-on-reset circuit 800 detects the power level of a biasing voltage of the pre-amplifier 506. When the power level of the biasing voltage of the pre-amplifier 506 is lower than a threshold, the power-on-reset circuit 800 enables the resetting signal VR to switch on the switch circuit 508, thus coupling the node 520 to the ground VGND to avoid generation of a popping noise. Referring to FIG. 12(b), another embodiment of control logic 510 of FIG. 8 is shown. In the embodiment, the control logic 510 is a clock detection circuit 850. The clock detection circuit 850 detects a clock signal C frequency for operating the microphone circuit 500. When the frequency of the clock signal C is lower than a threshold, the clock detection circuit 850 enables the resetting signal VR to switch on the switch circuit 508, thus coupling the node 520 to the ground VGND to avoid generation of a popping noise.

[0142] In one embodiment, the switch circuit 508 is an NMOS transistor coupled between the node 520 and the ground VGND. The NMOS transistor has a gate coupled to the resetting voltage VR generated by the control logic 510. If the switch circuit 508 is an NMOS transistor, a noise is generated with a sound level less than that of the original popping noise when the control logic 510 switches off the switch circuit 508. Referring to FIG. 9, a cross-section view of an NMOS transistor 500 is shown. The NMOS transistor 500 has a gate on a substrate, and a source and a drain in the substrate. The gate, source, and drain are respectively coupled to the resetting signal VR, the ground voltage VGND, and the node 520. When the control logic 510 enables the resetting voltage VR to turn on the NMOS transistor 500, a charge amount Q is attracted by the gate voltage to form an inversion layer beneath the insulator. When the control logic 510 disables the resetting signal VR, the inversion layer vanishes, and a charge amount of Q/2 flows to the drain and source of

the NMOS transistor **500**, inducing a temporary voltage change at the node **520** and producing a noise.

**[0143]** Assume that the NMOS transistor **500** has a width of  $1\ \mu\text{m}$ , a length of  $0.35\ \mu\text{m}$ , and the resetting voltage is  $1.8\text{V}$ , then the sheet capacitance of the gate oxide is  $5\ \text{fF}/\mu\text{m}^2$ . The gate capacitance of the NMOS transistor **500** is therefore equal to  $(5\ \text{fF}/\mu\text{m}^2 \times 1\ \mu\text{m} \times 0.35\ \mu\text{m}) = 1.75\ \text{fF}$ , and the charge  $Q$  stored in the inversion layer is therefore equal to  $(1.75\ \text{fF} \times 1.8\text{V}) = 3.15\ \text{fC}$ . The drain of the NMOS transistor **500** has capacitance of  $(5\ \text{pF} + 200\ \text{fF}) = 5.2\ \text{pF}$ , and the temporary voltage change at the node **520** is therefore equal to  $(3.15\ \text{fC} / 5.2\ \text{pF}) = 0.6\ \text{mV}$ . With the NMOS switch **500**, the node **520** of the microphone circuit **500** has a temporary voltage change of  $0.6\ \text{mV}$  instead of a popping noise of  $64\ \text{mV}$  during a reset period. The temporary voltage change of  $0.6\ \text{mV}$ , however, still produces an audible sound with a  $63\ \text{dB}$  sound pressure level. Thus, two more embodiments of the switch circuit **508** are introduced to solve the problem.

**[0144]** Referring to FIG. 10, a block diagram of an embodiment of a switch circuit **600** is shown. The switch circuit **600** can include an inverter **602** and NMOS transistors **604** and **606**, wherein a size of the NMOS transistor **606** is equal to a half of that of the NMOS transistor **604**. When the control logic **510** enables the resetting signal  $VR$ , the NMOS transistor **604** is turned on to couple the node **520** to the ground voltage  $VGND$ , and the NMOS transistor **606** is turned off. When the control logic **510** disables the resetting signal  $VR$ , the NMOS transistor **604** is turned off to decouple the node **520** from the ground voltage  $VGND$ , and the NMOS transistor **606** is turned on. Charges originally stored in an inversion layer of the NMOS transistor **604** therefore flow from a drain of the NMOS transistor **604** to a source of the NMOS transistor **606** and are then absorbed by an inversion layer of the NMOS transistor **606**, preventing the aforementioned problem of temporary voltage change of the node **520**.

**[0145]** Referring to FIG. 11, a block diagram of another embodiment of a switch circuit **700** according to the invention is shown. The switch circuit **700** comprises an inverter **702**, an NMOS transistor **704**, and a PMOS transistor **706**, wherein a size of the NMOS transistor **704** is equal to that of the PMOS transistor **706**. When the control logic **510** enables the resetting signal  $VR$ , the NMOS transistor **704** is turned on to couple the node **520** to the ground voltage  $VGND$ , and the PMOS transistor **706** is turned off. When the control logic **510** disables the resetting signal  $VR$ , the NMOS transistor **704** is turned off to decouple the node **520** from the ground voltage  $VGND$ , and the PMOS transistor **706** is turned on. Charges originally stored in an inversion layer of the NMOS transistor **704** therefore flow from a drain of the NMOS transistor **704** to a drain of the PMOS transistor **706** and are then absorbed by an inversion layer of the PMOS transistor **706**, preventing the aforementioned problem of temporary voltage change of the node **520**.

#### Gesture

**[0146]** FIG. 13 is a diagram that provides an overview of motion pattern classification and gesture recognition. Motion pattern classification system **900** is a system including one or more computers programmed to generate one or more motion patterns from empirical data. Motion pattern classification system **900** can receive motion samples **902** as training data from at least one motion/movement/gesture detection device

**904**. Each of the motion samples **902** can include a time series of readings of a motion sensor of motion/movement/gesture detection device **904**.

**[0147]** Motion pattern classification system **900** can process the received motion samples **902** and generate one or more motion patterns **906**. Each of the motion patterns **906** can include a series of motion vectors. Each motion vector can include linear acceleration values, angular rate values, or both, on three axes of a Cartesian coordinate frame (e.g.,  $X$ ,  $Y$ ,  $Z$  or pitch, yaw, roll). Each motion vector can be associated with a timestamp. Each motion pattern **906** can serve as a prototype to which motions are compared such that a gesture can be recognized. Motion pattern classification system **900** can send motion patterns **906** to motion/movement/gesture detection device **920** for gesture recognition.

**[0148]** Mobile device **920** can include, or be coupled to, gesture recognition system **922**. Gesture recognition system **922** is a component of motion/movement/gesture detection device **920** that includes hardware, software, or both that are configured to identify a gesture based on motion patterns **906**. Mobile device **920** can move (e.g., from a location A to a location B) and change orientations (e.g., from a face-up orientation on a table to an upright orientation near a face) following motion path **924**. When motion/movement/gesture detection device **920** moves, a motion sensor of motion/movement/gesture detection device **920** can provide a series of sensor readings **926** (e.g., acceleration readings or angular rate readings). Gesture recognition system **922** can receive sensor readings **926** and filter sensor readings **926**. Gesture recognition system **922** can compare the filtered sensor readings **926** with the motion patterns **906**. If a match is found, motion/movement/gesture detection device **920** can determine that a gesture is recognized. Based on the recognized gesture, motion/movement/gesture detection device can perform a task associated with the motion patterns **906** (e.g., turning off a display screen of motion/movement/gesture detection device **920**).

**[0149]** FIG. 14 is a block diagram of an exemplary system configured to perform operations of motion pattern classification. Motion pattern classification system **900** can receive motion samples **902** from motion/movement/gesture detection device **904**, generate prototype motion patterns **906** based on motion samples **902**, and send prototype motion patterns **906** to motion/movement/gesture detection device **920**.

**[0150]** Mobile device **904** is a device configured to gather motion samples **902**. An application program executing on motion/movement/gesture detection device **904** can provide for display a user interface requesting a user to perform a specified physical gesture with motion/movement/gesture detection device **904** one or more times. The specified gesture can be, for example, a gesture of picking up motion/movement/gesture detection device **904** from a table or a pocket and putting motion/movement/gesture detection device **904** near a human face. The gesture can be performed in various ways (e.g., left-handed or right-handed). The user interface is configured to prompt the user to label a movement each time the user completes the movement. The label can be positive, indicating the user acknowledges that the just-completed movement is a way of performing the gesture. The label can be negative, indicating that the user specifies that the just-completed movement is not a way of performing the gesture. Mobile device **904** can record a series of motion sensor readings during the movement. Mobile device **904** can designate

the recorded series of motion sensor readings, including those labeled as positive or negative, as motion samples 902. The portions of motion samples 902 that are labeled negative can be used as controls for tuning the motion patterns 906. Motion samples 902 can include multiple files, each file corresponding to a motion example and a series of motion sensor readings. Content of each file can include triplets of motion sensor readings (3 axes of sensed acceleration), each triplet being associated with a timestamp and a label. The label can include a text string or a value that designates the motion sample as a positive sample or a negative sample.

[0151] Motion pattern classification system 900 can include dynamic filtering subsystem 1002. Dynamic filtering subsystem 1002 is a component of motion pattern classification system 900 that is configured to generate normalized motion samples (also referred to as motion features) 1004 based on motion samples 902. Dynamic filtering subsystem 1002 can high-pass filter each of motion samples 902. High-pass filtering of motion samples 902 can include reducing a dimensionality of the motion example and compressing the motion sample in time such that each of motion samples 902 has a similar length in time. Further details of the operations of dynamic filtering subsystem 1002 will be described below in reference to FIG. 15.

[0152] Motion pattern classification system 900 can include distance calculating subsystem 1006. Distance calculating subsystem 1006 is a component of motion pattern classification system 900 that is configured to calculate a distance between each pair of motion features 1004. Distance calculating subsystem 1006 can generate a D-path matrix 1008 of distances. The distance between a pair of motion features 1004 can be a value that indicates a similarity between two motion features. Further details of the operations of calculating a distance between a pair of motion features 1004 and of the D-path matrix 1008 will be described below in reference to FIG. 16.

[0153] Motion pattern classification system 900 can include clustering subsystem 1010. Clustering subsystem 1010 is a component of motion pattern classification system 900 that is configured to generate one or more raw motion patterns 1012 based on the D-path matrix 1008 from the distance calculating system 1006. Each of the raw motion patterns 1012 can include a time series of motion vectors. The time series of motion vectors can represent a cluster of motion features 1004. The cluster can include one or more motion features 1004 that clustering subsystem 1010 determines to be sufficiently similar such that they can be treated as a class of motions. Further details of operations of clustering subsystem 1010 will be described below in reference to FIG. 17.

[0154] Motion pattern classification system 900 can include sphere-of-influence (SOI) calculating subsystem 1014. SOI calculating subsystem 1014 is a component of the motion pattern classification system 900 configured to generate one or more motion patterns 906 based on the raw motion patterns 1012 and the D-path matrix 1008. Each of the motion patterns 906 can include a raw motion pattern 1012 associated with an SOI. The SOI of a motion pattern is a value or a series of values that can indicate a tolerance or error margin of the motion pattern. A gesture recognition system can determine that a series of motion sensor readings match a motion pattern if the gesture recognition system determines that a distance between the series of motion sensor readings and the motion pattern is smaller than the SOI of the motion pattern. Further details of the operations of SOI calculating

subsystem 1014 will be described below in reference FIGS. 18(a)-(c). The motion pattern classification system 900 can send the motion patterns 906 to device 920 to be used by device 920 to perform pattern-based gesture recognition.

[0155] FIG. 15 is a diagram illustrating exemplary operations of dynamic filtering motion sample data. Motion example 1102 can be one of the motion samples 902 (as described above in reference to FIGS. 13-14). Motion sample 1102 can include a time series of motion sensor readings 1104, 1106a-c, 1108, etc. Each motion sensor reading is shown in one dimension ("A") for simplicity. Each motion sensor reading can include three acceleration values, one on each axis in a three dimensional space.

[0156] Dynamic filtering subsystem 1002 (as described in reference to FIG. 14) can receive motion sample 1102 and generate motion feature 1122. Motion feature 1122 can be one of the motion features 1004. Motion feature 1122 can include one or more motion vectors 1124, 1126, 1128, etc. To generate the motion feature 1122, dynamic filtering subsystem 1002 can reduce the motion sample 1102 in the time dimension. In some implementations, dynamic filtering subsystem 1002 can apply a filtering threshold to motion sample 1102. The filtering threshold can be a specified acceleration value. If a motion sensor reading 1108 exceeds the filtering threshold on at least one axis (e.g., axis X), dynamic filtering subsystem 1002 can process a series of one or more motion sensor readings 1106a-c that precede the motion sensor reading 1108 in time. Processing the motion sensor readings 1106a-c can include generating motion vector 1126 for replacing motion sensor readings 1106a-c. Dynamic filtering subsystem 1002 can generate motion vector 1126 by calculating an average of motion sensor readings 1106a-c. In a three-dimensional space, motion vector 1126 can include an average value on each of multiple axes. Thus, dynamic filtering subsystem 1002 can create motion feature 1122 that has fewer data points in the time series.

[0157] In some implementations, dynamic filtering subsystem 1002 can remove the timestamps of the motion samples such that motion feature 1122 includes an ordered series of motion vectors. The order of the series can implicitly indicate a time sequence. Dynamic filtering subsystem 1002 can preserve the labels associated with motion sample 1102. Accordingly, each motion vector in motion feature 1122 can be associated with a label.

[0158] FIG. 16 is a diagram illustrating exemplary dynamic time warp techniques used in distance calculating operations of motion pattern classification. Distance calculating subsystem 1006 (as described in reference to FIG. 14) can apply dynamic time warp techniques to calculate a distance between a first motion feature (e.g., Ea) and a second motion feature (e.g., Eb). The distance between Ea and Eb will be designated as D(Ea, Eb).

[0159] In the example shown, Ea includes a time series of m accelerometer readings  $r(a, 1)$  through  $r(a, m)$ . Eb includes a time series of n accelerometer readings  $r(b, 1)$  through  $r(b, n)$ . In some implementations, the distance calculating subsystem 1006 calculates the distance D(Ea, Eb) by employing a directed graph 1200. Directed graph 1200 can include  $m \times n$  nodes. Each node can be associated with a cost. The cost of a node (i, j) can be determined based on a distance between accelerometer readings  $r(a, i)$  and  $r(b, j)$ . For example, node 1202 can be associated with a distance between accelerometer readings  $r(a, 5)$  of Ea and accelerometer readings  $r(b, 2)$  of Eb. The distance can be a Euclidean distance, a Manhattan

distance, or any other distance between two values in an n-dimensional space (e.g., a three-dimensional space).

[0160] Distance calculating subsystem 1006 can add a directed edge from a node (i, j) to a node (i, j+1) and from the node (i, j) to a node (i+1, j). The directed edges thus can form a grid, in which, in this example, multiple paths can lead from the node (1, 1) to the node (m, n).

[0161] Distance calculating subsystem 1006 can add, to directed graph 1200, a source node S and a directed edge from S to node (1, 1), and target node T and a directed edge from node (m, n) to T. Distance calculating subsystem 1006 can determine a shortest path (e.g., the path marked in bold lines) between S and T, and designate the cost of the shortest path as the distance between motion features Ea and Eb.

[0162] When distance calculating subsystem 1006 receives y of motion features E1 . . . Ey, distance calculating subsystem 1006 can create a y-by-y matrix, an element of which is a distance between two motion features. For example, element (a, b) of the y-by-y matrix is the distance D(Ea, Eb) between motion features Ea and Eb. Distance calculating subsystem 1006 can designate the y-by-y matrix as D-path matrix 1008 as described above in reference to FIG. 14.

[0163] FIG. 20 is a diagram illustrating exemplary clustering techniques of motion pattern classification. The diagram is shown in a two-dimensional space for illustrative purposes. In some implementations, the clustering techniques are performed in a three-dimensional space. Clustering subsystem 1006 (as described in reference to FIG. 14) can apply quality threshold techniques to create exemplary clusters of motions C1 and C2.

[0164] Clustering subsystem 1006 can analyze D-path matrix 1008 as described above in references to FIG. 14 and FIG. 16 and the motion features 1004 as described above in reference to FIG. 14. Clustering subsystem 1006 can identify a first class of motion features 1004 having a first label (e.g., those labeled as “positive”) and a second class of motion features 1004 having a second label (e.g., those labeled as “negative”). From D-path matrix 1008, clustering subsystem 1006 can identify a specified distance (e.g., a minimum distance) between a first class motion feature (e.g., “positive” motion feature 1302) and a second class motion feature (e.g., “negative” motion feature 1304). The system can designate this distance as  $D_{\min}(EL1, EL2)$ , where L1 is a first label, and L2 is a second label. The specified distance can include the minimum distance adjusted by a factor (e.g., a multiplier k) for controlling the size of each cluster. Clustering subsystem 1006 can designate the specified distance (e.g.,  $kD_{\min}(EL1, EL2)$ ) as a quality threshold.

[0165] Clustering subsystem 1006 can select a first class motion feature E1 (e.g., “positive” motion feature 1302) to add to a first cluster C1. Clustering subsystem 1006 can then identify a second first class motion feature E2 whose distance to E1 is less than the quality threshold, and add E2 to the first cluster C1. Clustering subsystem 1006 can iteratively add first class motion features to the first cluster C1 until all first class motion features whose distances to E1 are each less than the quality threshold has been added to the first cluster C1.

[0166] Clustering subsystem 1006 can remove the first class motion features in C1 from further clustering operations and select another first class motion feature E2 (e.g., “positive” motion feature 1306) to add to a second cluster C2. Clustering subsystem 1006 can iteratively add first class motion features to the second cluster C2 until all first class motion features whose distances to E2 are each less than the

quality threshold have been added to the second cluster C2. Clustering subsystem 1006 can repeat the operations to create clusters C3, C4, and so on until all first class motion features are clustered.

[0167] Clustering subsystem 1006 can generate a representative series of motion vectors for each cluster. In some implementations, clustering subsystem 1006 can designate as the representative series of motion vectors a motion feature (e.g., motion feature 1308 illustrated in FIG. 17) that is closest to other motion samples in a cluster (e.g., cluster C1). Clustering subsystem 1006 can designate the representative series of motion vectors as a raw motion pattern (e.g., one of raw motion patterns 1012 as described above in reference to FIG. 14). To identify an example that is closest to other samples, clustering subsystem 1006 can calculate distances between pairs of motion features in cluster C1, and determine a reference distance for each motion sample. The reference distance for a motion sample can be maximum distance between the motion sample and another motion sample in the cluster. Clustering subsystem 1006 can identify motion feature 1308 in cluster C1 that has the minimum reference distance and designate motion feature 1308 as the motion pattern for cluster C1.

[0168] FIGS. 18(a)-(c) are diagrams illustrating techniques for determining a sphere of influence of a motion pattern. FIG. 18(a) is an illustration of a SOI of a motion pattern P. The SOI has a radius r that can be used as a threshold. If a distance between a motion M1 and the motion pattern P does not exceed r, a gesture recognition system can determine that motion M1 matches motion P. The match can indicate that a gesture is recognized. If a distance between a motion M2 and the motion pattern P exceeds r, the gesture recognition system can determine that motion M2 does not match motion P.

[0169] FIG. 18B is an illustration of exemplary operations of SOI calculating subsystem 1014 (as described above in reference to FIG. 14) for calculating a radius r1 of a SOI of a raw motion pattern P based on classification. SOI calculating subsystem 1014 can rank motion features 1004 based on a distance between each of the motion features 1004 and a raw motion pattern P. SOI calculating subsystem 1014 can determine the radius r1 based on a classification threshold and a classification ratio, which will be described below.

[0170] The radius r1 can be associated with a classification ratio. The classification ratio can be a ratio between a number of first class motion samples (e.g., “positive” motion samples) within distance r1 from the raw motion pattern P and a total number of motion samples (e.g., both “positive” and “negative” motion samples) within distance r1 from the motion pattern P.

[0171] SOI calculating subsystem 1014 can specify a classification threshold and determine the radius r1 based on the classification threshold. SOI calculating subsystem 1014 can increase the radius r1 from an initial value (e.g., 0) incrementally according to the incremental distances between the ordered motion samples and the raw motion pattern P. If, after r1 reaches a value (e.g., a distance between motion feature 1012 and raw motion pattern P), a further increment of r1 to a next closest distance between a motion feature (e.g., motion feature 1414) and raw motion pattern P will cause the classification ratio to be less than the classification threshold, SOI calculating subsystem 1014 can designate the value of r1 as a classification radius of the ROI.

[0172] FIG. 18(c) is an illustration of exemplary operations of SOI calculating subsystem 1014 (as described above in

reference to FIG. 14) for calculating a density radius  $r2$  of a SOI of raw motion pattern P based on variance. SOI calculating subsystem 1014 can rank motion features 1004 based on a distance between each of the motion features 1004 and a motion pattern P. SOI calculating subsystem 1014 can determine the density radius  $r2$  based on a variance threshold and a variance value, which will be described in further detail below.

[0173] The density radius  $r2$  can be associated with a variance value. The variance value can indicate a variance of distance between each of the motion samples that are within distance  $r2$  of the raw motion pattern P. SOI calculating subsystem 1014 can specify a variance threshold and determine the density radius  $r2$  based on the variance threshold. SOI calculating subsystem 1014 can increase a measuring distance from an initial value (e.g., 0) incrementally according to the incremental distances between the ordered motion samples and the motion pattern P. If, after the measuring distance reaches a value (e.g., a distance between motion feature 1422 and raw motion pattern P), a further increment of measuring distance to a next closest distance between a motion feature (e.g., motion feature 1424) and the raw motion pattern P will cause the variance value to be greater than the variance threshold, SOI calculating subsystem 1014 can designate an average  $(D1+D2)/2$  of the distance D1 between motion feature 1422 and the motion pattern P and the distance D2 between motion feature 1424 and the motion pattern P as the density radius  $r2$  of the SOI.

[0174] In some implementations, SOI calculating subsystem 1014 can select the smaller between the classification radius and the density radius of an SOI as the radius of the SOI. In some implementations, SOI calculating subsystem 1014 can designate a weighted average of the classification radius and the density radius of an SOI as the radius of the SOI.

[0175] FIG. 19 is a flowchart illustrating exemplary process 1500 of pattern-based gesture recognition. The process can be executed by a system including a motion/movement/gesture detection device.

[0176] The system can receive multiple motion patterns. Each of the motion patterns can include a time series of motion vectors. For clarity, the motion vectors in the motion patterns will be referred to as motion pattern vectors. Each of the motion patterns can be associated with an SOI. Each motion pattern vector can include a linear acceleration value, an angular rate value, or both, on each of multiple motion axes. In some implementations, each of the motion pattern vectors can include an angular rate value on each of pitch, roll, and yaw. Each of the motion patterns can include gyroscope data determined based on a gyroscope device of the motion/movement/gesture detection device, magnetometer data determined based on a magnetometer device of the motion/movement/gesture detection device, or gravimeter data from a gravimeter device of the motion/movement/gesture detection device. Each motion pattern vector can be associated with a motion pattern time. In some implementations, the motion pattern time is implied in the ordering of the motion pattern vectors.

[0177] The system can receive multiple motion sensor readings from a motion sensor built into or coupled with the system. The motion sensor readings can include multiple motion vectors, which will be referred to as motion reading vectors. Each motion reading vector can correspond to a timestamp, which can indicate a motion reading time. In

some implementations, each motion reading vector can include an acceleration value on each of the axes as measured by the motion sensor, which includes an accelerometer. In some implementations, each motion reading vector can include a transformed acceleration value that is calculated based on one or more acceleration values as measured by the motion sensor. The transformation can include high-pass filtering, time-dimension compression, or other manipulations of the acceleration values. In some implementations, the motion reading time is implied in the ordering of the motion reading vectors.

[0178] The system can select, using a time window and from the motion sensor readings, a time series of motion reading vectors. The time window can include a specified time period and a beginning time. In some implementations, transforming the acceleration values can occur after the selection stage. The system can transform the selected time series of acceleration values.

[0179] The system can calculate a distance between the selected time series of motion reading vectors and each of the motion patterns. This distance will be referred to as a motion deviation distance. Calculating the motion deviation distance can include applying dynamic time warping based on the motion pattern times of the motion pattern and the motion reading times of the series of motion reading vectors. Calculating the motion deviation distance can include calculating a vector distance between (1) each motion reading vector in the selected time series of motion reading vectors, and (2) each motion pattern vector in the motion pattern. The system can then calculate the motion deviation distance based on each vector distance. Calculating the motion deviation distance based on each vector distance can include identifying a series of vector distances ordered according to the motion pattern times and the motion reading times (e.g., the identified shortest path described above with respect to FIG. 9B). The system can designate a measurement of the vector distances in the identified series as the motion deviation distance. The measurement can include at least one of a sum or a weighted sum of the vector distances in the identified series. The vector distances can include at least one of a Euclidean distance between a motion pattern vector and a motion reading vector or a Manhattan distance between a motion pattern vector and a motion reading vector.

[0180] The system can determine whether a match is found. Determining whether a match is found can include determining whether, according to a calculated motion deviation distance, the selected time series of motion reading vectors is located within the sphere of influence of a motion pattern (e.g., motion pattern P).

[0181] If a match is not found, the system slides the time window along a time dimension on the received motion sensor readings. Sliding the time window can include increasing the beginning time of the time window. The system can then perform operations 1504, 1506, 1508, and 1510 until a match is found, or until all the motion patterns have been compared against and no match is found.

[0182] If a match is found, a gesture is recognized. The system can designate the motion pattern P as a matching motion pattern. The system can perform (1014) a specified task based on the matching motion pattern. Performing the specific task can include at least one of: changing a configuration of a motion/movement/gesture detection device; providing a user interface for display, or removing a user interface from display on a motion/movement/gesture detection

device; launching or terminating an application program on a motion/movement/gesture detection device; or initiating or terminating a communication between a motion/movement/gesture detection device and another device. Changing the configuration of the motion/movement/gesture detection device includes changing an input mode of the motion/movement/gesture detection device between a touch screen input mode and a voice input mode.

[0183] In some implementations, before performing the specified task, the system can apply confirmation operations to detect and eliminate false positives in matching. The confirmation operations can include examining a touch-screen input device or a proximity sensor of the motion/movement/gesture detection device. For example, if the gesture is “picking up the device,” the device can confirm the gesture by examining proximity sensor readings to determine that the device is proximity to an object (e.g., a human face) at the end of the gesture.

[0184] FIG. 20 is a block diagram illustrating an exemplary system configured to perform operations of gesture recognition. The system can include motion sensor 1602, gesture recognition system 122, and application interface 1604. The system can be implemented on a mobile device.

[0185] Motion sensor 1602 can be a component of a mobile device that is configured to measure accelerations in multiple axes and produces motion sensor readings 1606 based on the measured accelerations. Motion sensor readings 1606 can include a time series of acceleration vectors.

[0186] Gesture recognition system can be configured to receive and process motion sensor readings 1606. Gesture recognition system 122 can include dynamic filtering subsystem 1608. Dynamic filtering subsystem 1608 is a component of the gesture recognition system that is configured to perform dynamic filtering on motion sensor readings 1606 in a manner similar to the operations of dynamic filtering subsystem. In addition, dynamic filtering subsystem 1608 can be configured to select a portion of motion sensor readings 1606 for further processing. The selection can be based on sliding time window 1610. Motion sensor 1602 can generate motion sensor readings 1606 continuously. Dynamic filtering subsystem 1608 can use the sliding time window 1610 to select segments of the continuous data, and generate normalized motion sensor readings 1611 based on the selected segments.

[0187] Gesture recognition system can include motion identification subsystem 1612. Motion identification subsystem 1612 is a component of gesture recognition system 1622 that is configured to determine whether normalized motion sensor readings 1611 match a known motion pattern. Motion identification subsystem 1612 can receive normalized motion sensor readings 1611, and access motion pattern data store 1614. Motion pattern data store 1614 includes a storage device that stores one or more motion patterns 106. Motion identification subsystem 1612 can compare the received normalized motion sensor readings 1611 with each of the stored motion patterns, and recognize a gesture based on the comparison.

[0188] Motion identification subsystem 1612 can include distance calculating subsystem 1618. Distance calculating subsystem 1618 is a component of motion identification subsystem 1612 that is configured to calculate a distance between normalized motion sensor readings 1611 and each of the motion patterns 106. If the distance between normalized motion sensor readings 1611 and a motion pattern P is within the radius of an SOI of the motion pattern P, motion identifi-

cation subsystem 1612 can identify a match and recognize a gesture 1620. Further details of the operations of distance calculating subsystem 1618 will be described below in reference to FIGS. 21(a) and (b).

[0189] Motion identification subsystem 1612 can send the recognized gesture 1620 to application interface 1604. An application program or a system function of the mobile device can receive the gesture from application interface 1604 and perform a task (e.g., turning off a touch-input screen) in response.

[0190] FIGS. 21(a) and (b) are diagrams illustrating techniques of matching motion sensor readings to a motion pattern. FIG. 21(a) illustrates an example data structure of normalized motion sensor readings 1611. Normalized motion sensor readings 1611 can include a series of motion vectors 1622. Each motion vector 1622 can include acceleration readings  $a_x$ ,  $a_y$ , and  $a_z$ , for axes X, Y, and Z, respectively. In some implementations, each motion vector 1622 can be associated with a time  $t_i$ , the time defining the time series. In some implementations, the normalized motion sensor readings 1611 designate the time dimension of the time series using an order of the motion vectors 1622. In these implementations, the time can be omitted.

[0191] Distance calculating subsystem 1618 (as described above in reference to FIG. 20) compares normalized motion sensor readings 1611 to each of the motion patterns 1606a, 1606b, and 1606c. The operations of comparison are described in further detail below in reference to FIG. 21(b). A match between normalized motion sensor readings 1611 and any of the motion patterns 1606a, 1606b, and 1606c can result in a recognition of a gesture.

[0192] FIG. 21(b) is a diagram illustrating distance calculating operations of distance calculating subsystem 1618. To perform the comparison, distance calculating subsystem 1618 can calculate a distance between the normalized motion sensor readings 1611, which can include readings R1, Rn, and a motion pattern (e.g., motion pattern 1606a, 1606b, or 1606c), which can include motion vectors V1 . . . Vm. Distance calculating subsystem 1618 can calculate the distance using directed graph 1624 in operations similar to those described in reference to FIG. 20.

[0193] In some implementations, distance calculating subsystem 1618 can perform optimization on the comparing. Distance calculating subsystem 1618 can perform the optimization by applying comparison thresholds 1626 and 1628. Comparison thresholds 1626 and 1628 can define a series of vector pairs between which distance calculating subsystem 1618 performs a distance calculation. By applying comparison thresholds 1626 and 1628, distance calculating subsystem 1618 can exclude those calculations that are unlikely to yield a match. For example, a distance calculation between the first motion vector R1 in the normalized motion sensor readings 1611 and a last motion vector Vm of a motion pattern is unlikely to lead to a match, and therefore can be omitted from the calculations.

[0194] Distance calculating subsystem 1618 can determine a shortest path (e.g., the path marked in bold lines) in directed graph 1624, and designate the cost of the shortest path as a distance between normalized motion sensor readings 1611 and a motion pattern. Distance calculating subsystem 1618 can compare the distance with a SOI associated with the motion pattern. If the distance is less than the SOI, distance calculating subsystem 1618 can identify a match.

**[0195]** FIG. 22 is a flowchart illustrating exemplary process 1700 of pattern-based gesture recognition. The process can be executed by a system including a mobile device.

**[0196]** The system can receive (1702) multiple motion patterns. Each of the motion patterns can include a time series of motion vectors. For clarity, the motion vectors in the motion patterns will be referred to as motion pattern vectors. Each of the motion patterns can be associated with an SOI. Each motion pattern vector can include a linear acceleration value, an angular rate value, or both, on each of multiple motion axes. In some implementations, each of the motion pattern vectors can include an angular rate value on each of pitch, roll, and yaw. Each of the motion patterns can include gyroscope data determined based on a gyroscope device of the mobile device, magnetometer data determined based on a magnetometer device of the mobile device, or gravimeter data from a gravimeter device of the mobile device. Each motion pattern vector can be associated with a motion pattern time. In some implementations, the motion pattern time is implied in the ordering of the motion pattern vectors.

**[0197]** The system can receive (1704) multiple motion sensor readings from a motion sensor built into or coupled with the system. The motion sensor readings can include multiple motion vectors, which will be referred to as motion reading vectors. Each motion reading vector can correspond to a timestamp, which can indicate a motion reading time. In some implementations, each motion reading vector can include an acceleration value on each of the axes as measured by the motion sensor, which includes an accelerometer. In some implementations, each motion reading vector can include a transformed acceleration value that is calculated based on one or more acceleration values as measured by the motion sensor. The transformation can include high-pass filtering, time-dimension compression, or other manipulations of the acceleration values. In some implementations, the motion reading time is implied in the ordering of the motion reading vectors.

**[0198]** The system can select (1706), using a time window and from the motion sensor readings, a time series of motion reading vectors. The time window can include a specified time period and a beginning time. In some implementations, transforming the acceleration values can occur after the selection stage. The system can transform the selected time series of acceleration values.

**[0199]** The system can calculate (1708) a distance between the selected time series of motion reading vectors and each of the motion patterns. This distance will be referred to as a motion deviation distance. Calculating the motion deviation distance can include applying dynamic time warping based on the motion pattern times of the motion pattern and the motion reading times of the series of motion reading vectors. Calculating the motion deviation distance can include calculating a vector distance between (1) each motion reading vector in the selected time series of motion reading vectors, and (2) each motion pattern vector in the motion pattern. The system can then calculate the motion deviation distance based on each vector distance. Calculating the motion deviation distance based on each vector distance can include identifying a series of vector distances ordered according to the motion pattern times and the motion reading times (e.g., the identified shortest path described above with respect to FIG. 9B). The system can designate a measurement of the vector distances in the identified series as the motion deviation distance. The measurement can include at least one of a sum or

a weighted sum of the vector distances in the identified series. The vector distances can include at least one of a Euclidean distance between a motion pattern vector and a motion reading vector or a Manhattan distance between a motion pattern vector and a motion reading vector.

**[0200]** The system can determine (1710) whether a match is found. Determining whether a match is found can include determining whether, according to a calculated motion deviation distance, the selected time series of motion reading vectors is located within the sphere of influence of a motion pattern (e.g., motion pattern P).

**[0201]** If a match is not found, the system slides (1712) the time window along a time dimension on the received motion sensor readings. Sliding the time window can include increasing the beginning time of the time window. The system can then perform operations 1704, 1706, 1708, and 1710 until a match is found, or until all the motion patterns have been compared against and no match is found.

**[0202]** If a match is found, a gesture is recognized. The system can designate the motion pattern P as a matching motion pattern. The system can perform (1714) a specified task based on the matching motion pattern. Performing the specific task can include at least one of: changing a configuration of a mobile device; providing a user interface for display, or removing a user interface from display on a mobile device; launching or terminating an application program on a mobile device; or initiating or terminating a communication between a mobile device and another device. Changing the configuration of the mobile device includes changing an input mode of the mobile device between a touch screen input mode and a voice input mode.

**[0203]** In some implementations, before performing the specified task, the system can apply confirmation operations to detect and eliminate false positives in matching. The confirmation operations can include examining a touch-screen input device or a proximity sensor of the mobile device. For example, if the gesture is "picking up the device," the device can confirm the gesture by examining proximity sensor readings to determine that the device is proximity to an object (e.g., a human face) at the end of the gesture.

**[0204]** FIG. 23 is a block diagram illustrating exemplary device architecture 1800 of a device implementing the features and operations of pattern-based gesture recognition. The device can include memory interface 1802, one or more data processors, image processors and/or processors 1804, and peripherals interface 1806. Memory interface 1802, one or more processors 1804 and/or peripherals interface 1806 can be separate components or can be integrated in one or more integrated circuits. Processors 1804 can include one or more application processors (APs) and one or more baseband processors (BPs). The application processors and baseband processors can be integrated in one single process chip. The various components in a motion/movement/gesture detection device, for example, can be coupled by one or more communication buses or signal lines.

**[0205]** Sensors, devices, and subsystems can be coupled to peripherals interface 1806 to facilitate multiple functionalities. For example, motion sensor 1810, light sensor 1812, and proximity sensor 1814 can be coupled to peripherals interface 1806 to facilitate orientation, lighting, and proximity functions of the motion/movement/gesture detection device. Location processor 1815 (e.g., GPS receiver) can be connected to peripherals interface 1806 to provide geo-positioning. Electronic magnetometer 1816 (e.g., an integrated circuit

chip) can also be connected to peripherals interface **1806** to provide data that can be used to determine the direction of magnetic North. Thus, electronic magnetometer **1816** can be used as an electronic compass. Motion sensor **1810** can include one or more accelerometers configured to determine change of speed and direction of movement of the motion/movement/gesture detection device. Gravimeter **1817** can include one or more devices connected to peripherals interface **1806** and configured to measure a local gravitational field of Earth.

[**0206**] Camera subsystem **1820** and an optical sensor **1822**, e.g., a charged coupled device (CCD) or a complementary metal-oxide semiconductor (CMOS) optical sensor, can be utilized to facilitate camera functions, such as recording photographs and video clips.

[**0207**] Communication functions can be facilitated through one or more wireless communication subsystems **1824**, which can include radio frequency receivers and transmitters and/or optical (e.g., infrared) receivers and transmitters. The specific design and implementation of the communication subsystem **1824** can depend on the communication network(s) over which a motion/movement/gesture detection device is intended to operate. For example, a motion/movement/gesture detection device can include communication subsystems **1824** designed to operate over a CDMA system, a WiFi™ or WiMax™ network, and a Bluetooth™ network. In particular, the wireless communication subsystems **1824** can include hosting protocols such that the motion/movement/gesture detection device can be configured as a base station for other wireless devices.

[**0208**] Audio subsystem **1826** can be coupled to a speaker **1828** and a microphone **1830** to facilitate voice-enabled functions, such as voice recognition, voice replication, digital recording, and telephony functions.

[**0209**] I/O subsystem **1840** can include touch screen controller **1842** and/or other input controller(s) **1844**. Touch-screen controller **1842** can be coupled to a touch screen **1846** or pad. Touch screen **1846** and touch screen controller **1842** can, for example, detect contact and movement or break thereof using any of a plurality of touch sensitivity technologies, including but not limited to capacitive, resistive, infrared, and surface acoustic wave technologies, as well as other proximity sensor arrays or other elements for determining one or more points of contact with touch screen **1846**.

[**0210**] Other input controller(s) **1844** can be coupled to other input/control devices **1848**, such as one or more buttons, rocker switches, thumb-wheel, infrared port, USB port, and/or a pointer device such as a stylus. The one or more buttons (not shown) can include an up/down button for volume control of speaker **1828** and/or microphone **1830**.

[**0211**] In one implementation, a pressing of the button for a first duration may disengage a lock of the touch screen **1846**; and a pressing of the button for a second duration that is longer than the first duration may turn power to a motion/movement/gesture detection device on or off. The user may be able to customize a functionality of one or more of the buttons. The touch screen **1846** can, for example, also be used to implement virtual or soft buttons and/or a keyboard.

[**0212**] In some implementations, a motion/movement/gesture detection device can present recorded audio and/or video files, such as MP3, AAC, and MPEG files. In some implementations, a motion/movement/gesture detection device can include the functionality of an MP3 player, such as an iPod™. A motion/movement/gesture detection device may, therefore,

include a pin connector that is compatible with the iPod. Other input/output and control devices can also be used.

[**0213**] Memory interface **1802** can be coupled to memory **1850**. Memory **1850** can include high-speed random access memory and/or non-volatile memory, such as one or more magnetic disk storage devices, one or more optical storage devices, and/or flash memory (e.g., NAND, NOR). Memory **1850** can store operating system **1852**, such as Darwin, RTXC, LINUX, UNIX, OS X, WINDOWS, or an embedded operating system such as VxWorks. Operating system **1852** may include instructions for handling basic system services and for performing hardware dependent tasks. In some implementations, operating system **1852** can include a kernel (e.g., UNIX kernel).

[**0214**] Memory **1850** may also store communication instructions **1854** to facilitate communicating with one or more additional devices, one or more computers and/or one or more servers. Memory **1850** may include graphical user interface instructions **1856** to facilitate graphic user interface processing; sensor processing instructions **1858** to facilitate sensor-related processing and functions; phone instructions **1860** to facilitate phone-related processes and functions; electronic messaging instructions **1862** to facilitate electronic-messaging related processes and functions; web browsing instructions **1864** to facilitate web browsing-related processes and functions; media processing instructions **1866** to facilitate media processing-related processes and functions; GPS/Navigation instructions **1868** to facilitate GPS and navigation-related processes and instructions; camera instructions **1870** to facilitate camera-related processes and functions; magnetometer data **1872** and calibration instructions **1874** to facilitate magnetometer calibration. The memory **1850** may also store other software instructions (not shown), such as security instructions, web video instructions to facilitate web video-related processes and functions, and/or web shopping instructions to facilitate web shopping-related processes and functions. In some implementations, the media processing instructions **1866** are divided into audio processing instructions and video processing instructions to facilitate audio processing-related processes and functions and video processing-related processes and functions, respectively. An activation record and International Mobile Equipment Identity (IMEI) or similar hardware identifier can also be stored in memory **1850**. Memory **1850** can include gesture recognition instructions **1876**. Gesture recognition instructions **1876** can be a computer program product that is configured to cause the motion/movement/gesture detection device to recognize one or more gestures using motion patterns, as described in reference to FIGS. **13-22**.

[**0215**] Each of the above identified instructions and applications can correspond to a set of instructions for performing one or more functions described above. These instructions need not be implemented as separate software programs, procedures, or modules. Memory **1850** can include additional instructions or fewer instructions. Furthermore, various functions of the motion/movement/gesture detection device may be implemented in hardware and/or in software, including in one or more signal processing and/or application specific integrated circuits.

#### Exemplary Operating Environment

[**0216**] FIG. **24** is a block diagram of exemplary network operating environment **1900** for the motion/movement/gesture detection devices implementing motion pattern classifi-

cation and gesture recognition techniques. Mobile devices **1902(a)** and **1902(b)** can, for example, communicate over one or more wired and/or wireless networks **1910** in data communication. For example, a wireless network **1912**, e.g., a cellular network, can communicate with a wide area network (WAN) **1914**, such as the Internet, by use of a gateway **1916**. Likewise, an access device **1918**, such as an 802.11g wireless access device, can provide communication access to the wide area network **1914**.

[0217] In some implementations, both voice and data communications can be established over wireless network **1912** and the access device **1918**. For example, motion/movement/gesture detection device **1902(a)** can place and receive phone calls (e.g., using voice over Internet Protocol (VoIP) protocols), send and receive e-mail messages (e.g., using Post Office Protocol 3 (POP3)), and retrieve electronic documents and/or streams, such as web pages, photographs, and videos, over wireless network **1912**, gateway **1916**, and wide area network **1914** (e.g., using Transmission Control Protocol/Internet Protocol (TCP/IP) or User Datagram Protocol (UDP)). Likewise, in some implementations, the motion/movement/gesture detection device **1902(b)** can place and receive phone calls, send and receive e-mail messages, and retrieve electronic documents over the access device **1918** and the wide area network **1914**. In some implementations, motion/movement/gesture detection device **1902(a)** or **1902(b)** can be physically connected to the access device **1918** using one or more cables and the access device **1918** can be a personal computer. In this configuration, motion/movement/gesture detection device **1902(a)** or **1902(b)** can be referred to as a “tethered” device.

[0218] Mobile devices **1902(a)** and **1902(b)** can also establish communications by other means. For example, wireless motion/movement/gesture detection device **1902(a)** can communicate with other wireless devices, e.g., other motion/movement/gesture detection devices **1902(a)** or **1902(b)**, cell phones, etc., over the wireless network **1912**. Likewise, motion/movement/gesture detection devices **1902(a)** and **1902(b)** can establish peer-to-peer communications **1920**, e.g., a personal area network, by use of one or more communication subsystems, such as the Bluetooth™ communication devices. Other communication protocols and topologies can also be implemented.

[0219] The motion/movement/gesture detection device **1902(a)** or **1902(b)** can, for example, communicate with one or more services **1930** and **1940** over the one or more wired and/or wireless networks. For example, one or more motion training services **1930** can be used to determine one or more motion patterns. Motion pattern service **1940** can provide the one or more one or more motion patterns to motion/movement/gesture detection devices **1902(a)** and **1902(b)** for recognizing gestures.

[0220] Mobile device **1902(a)** or **1902(b)** can also access other data and content over the one or more wired and/or wireless networks. For example, content publishers, such as news sites, Rally Simple Syndication (RSS) feeds, web sites, blogs, social networking sites, developer networks, etc., can be accessed by motion/movement/gesture detection device **1902(a)** or **1902(b)**. Such access can be provided by invocation of a web browsing function or application (e.g., a browser) in response to a user touching, for example, a Web object.

#### Exemplary System Architecture

[0221] FIG. 25 is a block diagram of exemplary system architecture for implementing the features and operations of motion pattern classification and gesture recognition. Other architectures are possible, including architectures with more or fewer components. In some implementations, architecture **2000** includes one or more processors **2002** (e.g., dual-core Intel® Xeon® Processors), one or more output devices **2004** (e.g., LCD), one or more network interfaces **2006**, one or more input devices **2008** (e.g., mouse, keyboard, touch-sensitive display) and one or more computer-readable media **2012** (e.g., RAM, ROM, SDRAM, hard disk, optical disk, flash memory, etc.). These components can exchange communications and data over one or more communication channels **2010** (e.g., buses), which can utilize various hardware and software for facilitating the transfer of data and control signals between components.

[0222] The term “computer-readable medium” refers to any medium that participates in providing instructions to processor **2002** for execution, including without limitation, non-volatile media (e.g., optical or magnetic disks), volatile media (e.g., memory) and transmission media. Transmission media includes, without limitation, coaxial cables, copper wire and fiber optics.

[0223] Computer-readable medium **2012** can further include operating system **2014** (e.g., Mac OS® server, Windows® NT server), network communications module **2016**, motion data collection subsystem **2020**, motion classification subsystem **2030**, motion pattern database **2040**, and motion pattern distribution subsystem **2050**. Motion data collection subsystem **2020** can be configured to receive motion samples from motion/movement/gesture detection devices. Motion classification subsystem **2030** can be configured to determine one or more motion patterns from the received motion samples. Motion pattern database **2040** can store the motion patterns. Motion pattern distribution subsystem **2050** can be configured to distribute the motion patterns to motion/movement/gesture detection devices. Operating system **2014** can be multi-user, multiprocessing, multitasking, multithreading, real time, etc. Operating system **2014** performs basic tasks, including but not limited to: recognizing input from and providing output to devices **2006**, **2008**; keeping track and managing files and directories on computer-readable media **2012** (e.g., memory or a storage device); controlling peripheral devices; and managing traffic on the one or more communication channels **2010**. Network communications module **2016** includes various components for establishing and maintaining network connections (e.g., software for implementing communication protocols, such as TCP/IP, HTTP, etc.). Computer-readable medium **2012** can further include a database interface. The database interface can include interfaces to one or more databases on a file system. The databases can be organized under a hierarchical folder structure, the folders mapping to directories in the file system.

[0224] Architecture **2000** can be included in any device capable of hosting a database application program. Architecture **2000** can be implemented in a parallel processing or peer-to-peer infrastructure or on a single device with one or more processors. Software can include multiple software components or can be a single body of code.

[0225] The described features can be implemented advantageously in one or more computer programs that are executable on a programmable system including at least one programmable processor coupled to receive data and instructions

from, and to transmit data and instructions to, a data storage system, at least one input device, and at least one output device. A computer program is a set of instructions that can be used, directly or indirectly, in a computer to perform a certain activity or bring about a certain result. A computer program can be written in any form of programming language (e.g., Objective-C, Java), including compiled or interpreted languages, and it can be deployed in any form, including as a stand-alone program or as a module, component, subroutine, a browser-based web application, or other unit suitable for use in a computing environment.

[0226] Suitable processors for the execution of a program of instructions include, by way of example, both general and special purpose microprocessors, and the sole processor or one of multiple processors or cores, of any kind of computer. Generally, a processor will receive instructions and data from a read-only memory or a random access memory or both. The essential elements of a computer are a processor for executing instructions and one or more memories for storing instructions and data. Generally, a computer will also include, or be operatively coupled to communicate with, one or more mass storage devices for storing data files; such devices include magnetic disks, such as internal hard disks and removable disks; magneto-optical disks; and optical disks. Storage devices suitable for tangibly embodying computer program instructions and data include all forms of non-volatile memory, including by way of example semiconductor memory devices, such as EPROM, EEPROM, and flash memory devices; magnetic disks such as internal hard disks and removable disks; magneto-optical disks; and CD-ROM and DVD-ROM disks. The processor and the memory can be supplemented by, or incorporated in, ASICs (application-specific integrated circuits).

[0227] To provide for interaction with a user, the features can be implemented on a computer having a display device such as a CRT (cathode ray tube) or LCD (liquid crystal display) monitor for displaying information to the user and a keyboard and a pointing device such as a mouse or a trackball by which the user can provide input to the computer.

[0228] The features can be implemented in a computer system that includes a back-end component, such as a data server, or that includes a middleware component, such as an application server or an Internet server, or that includes a front-end component, such as a client computer having a graphical user interface or an Internet browser, or any combination of them. The components of the system can be connected by any form or medium of digital data communication such as a communication network. Examples of communication networks include, e.g., a LAN, a WAN, and the computers and networks forming the Internet.

[0229] The computer system can include clients and servers. A client and server are generally remote from each other and typically interact through a network. The relationship of client and server arises by virtue of computer programs running on the respective computers and having a client-server relationship to each other.

#### Light Proximity

[0230] FIG. 26 illustrates a functional block diagram of a proximity sensor in one embodiment. As shown in FIG. 26, the proximity sensor 2101 includes a light emitter E and a light sensor R. The light emitter E includes a light-emitting diode LED used to emit lights. In one embodiment the light-

emitting diode LED can be an infrared ray light-emitting diode (IR LED) used to emit infrared rays, but is not limited to this.

[0231] In one embodiment, the light sensor R can be an integrated circuit including at least one light sensing unit and a control circuit. In FIG. 26, the light sensor R includes a proximity sensing unit PS, an ambient light sensing unit ALS, a sensed light processing unit 2110, an analog/digital converter 2111, a temperature compensating unit 2112, a digital signal processing unit 2113, an inter-integrated circuit (I2C) interface 2114, a buffer 2115, a LED driver 2116, an oscillator 2117, and a reference value generator 2118. The proximity sensing unit PS and the ambient light sensing unit ALS are coupled to the sensed light processing unit 2110; the temperature compensating unit 2112 is coupled to the sensed light processing unit 2110; the analog/digital converter 2111 is coupled to the sensed light processing unit 2110, the digital signal processing unit 2113, the I2C interface 2114, and the oscillator 2117 respectively; the digital signal processing unit 2113 is coupled to the analog/digital converter 2111, the I2C interface 2114, the buffer 2115, the LED driver 2116, and the oscillator 2117 respectively; the I2C interface 2114 is coupled to the analog/digital converter 2111, the digital signal processing unit 2113, the LED driver 2116, and the reference value generator 2118 respectively; the oscillator 2117 is coupled to the analog/digital converter 2111, the digital signal processing unit 2113, and the reference value generator 2118 respectively; the reference value generator 2118 is coupled to the I2C interface 2114 and the oscillator 2117 respectively.

[0232] In this embodiment, the ambient light sensing unit ALS is used to sense an ambient light intensity around the proximity sensor 2111. The sensed light processing unit 2110 is used to process the light signal sensed by the ambient light sensing unit ALS and the proximity sensing unit PS and to perform temperature compensation according to the temperature compensating unit 2112. The LED driver 2116 is used to drive the light-emitting diode LED. The oscillator 2117 can be a quartz oscillator. The reference value generator 2118 is used to generate a default reference value.

[0233] The user can use the I2C interface 2114 to set digital signal processing parameters needed by the digital signal processing unit 2113. When the object is close to the light sensor R, the lights emitted from the light-emitting diode LED will be reflected to the proximity sensing unit PS by the object, and then the reflected lights will be processed by the sensed light processing unit 2110 and converted into digital light sensing signals by the analog/digital converter 2111. Then, the digital signal processing unit 2113 will determine whether the object is close to the light sensor R according to the digital light sensing signal.

[0234] If the result determined by the digital signal processing unit 2113 is yes, the buffer 2115 will output a proximity notification signal to inform the electronic apparatus including the proximity sensor 2111 that the object is close to the electronic apparatus, so that the electronic apparatus can immediately make corresponding action. For example, a smart phone with the proximity sensor 2111 will know that the face of the user is close to the smart phone according to the proximity notification signal; therefore, the smart phone will shut down the touch function of the touch monitor to avoid the touch monitor being carelessly touched by the face of the user.

[0235] However, the proximity sensor 2111 may have noise crosstalk problem due to poor packaging or mechanical

design, which may cause the digital signal processing unit 2113 to make a misjudgment, and in turn causing the electronic apparatus, including the proximity sensor 2111, to malfunction. For example, if when the face of the user is not close to the smart phone, but the digital signal processing unit 2113 makes a misjudgment that an object is close to the smart phone, the smart phone will shut down the touch function of the touch monitor, and the user will not be able to use the touch function of the touch monitor. Therefore, the proximity sensor 2111 of this embodiment has three operation modes described as follows to solve the aforementioned malfunction problem.

[0236] The first operation mode is a manual setting mode. After the electronic apparatus, including the proximity sensor 2111, is assembled as shown in FIGS. 27(a) and (b) under the condition that no object is close to the proximity sensor 2111 of the electronic apparatus, if the proximity sensing unit PS senses a first measured value C1 when the light-emitting diode LED is active and emits the light L (see FIG. 27(a) and senses a second measured value C2 when the light-emitting diode LED is inactive (see FIG. 27(b)), since the second measured value C2 may include noise and the first measured value C1 may include noise and noise cross-talk (e.g., the portion reflected by the glass G), the digital signal processing unit 2113 can subtract the second measured value C2 from the first measured value C1 to obtain an initial noise cross-talk value CT under the condition that no object is close to the proximity sensor 2111 of the electronic apparatus, and store the initial noise cross-talk value CT in a register (not shown in the figure) through the I2C interface 2114. The initial noise cross-talk value CT can be used as a maximum threshold value of noise cross-talk in the system.

[0237] It should be noticed that since no object is close to the proximity sensor 2111 of the electronic apparatus at this time, the initial noise cross-talk value CT obtained by the digital signal processing unit 2113 should only include noise cross-talk values caused by the packaging and the mechanical portion of the system. Therefore, after the initial noise cross-talk value CT is obtained, whenever the proximity sensor 2111 tries to detect whether the object is close to the proximity sensor 2111, the digital signal processing unit 2113 needs to subtract the initial noise cross-talk value CT from the measured value to effectively reduce the effect of noise cross-talk.

[0238] The second operation mode is an automatic setting mode. Whenever the electronic apparatus, including the proximity sensor 2111, is active, the proximity sensor 2111 can obtain the initial noise cross-talk value CT by subtracting the second measured value C2 from the first measured value C1 as mentioned above, and the initial noise cross-talk value CT can be used as a standard to determine that the sensed value is noise, noise cross-talk, or light signal reflected by the object.

[0239] As shown in FIG. 27(c) through FIG. 27(f), after the electronic apparatus including the proximity sensor 2111 is active, the object 2 may be close to the proximity sensor 2111 of the electronic apparatus, and the object 2 may be located in the detection range of the proximity sensor 2111. If the proximity sensing unit PS senses a third measured value C3 when the light-emitting diode LED is active and emits the light L and senses a fourth measured value C4 when the light-emitting diode LED is inactive. Since the fourth measured value C4 may include the noise, and the third measured value C3 may include the noise, the noise cross-talk, and the light signal reflected by the object 2, the digital signal processing

unit 2113 can obtain a specific measured value M by subtracting the fourth measured value C4 from the third measured value C3, and the specific measured value M represents the noise cross-talk and the light signal reflected by the object 2.

[0240] Next, the digital signal processing unit 2113 determines whether the specific measured value M is larger than the initial noise cross-talk value CT. If the result determined by the digital signal processing unit 2113 is no, it means that the specific measured value M (the noise cross-talk and the light signal reflected by the object 2) at this time is smaller than the initial noise cross-talk value CT. Therefore, the proximity sensor 2111 needs to replace the initial noise cross-talk value CT stored in the register with the specific measured value M through the I2C interface 2114. Afterwards, when the proximity sensor 2111 detects whether any object is close to the proximity sensor 2111 again, the updated initial noise cross-talk value (the specific measured value M) will be used as a standard of determination.

[0241] If the result determined by the digital signal processing unit 2113 is yes, it means that the specific measured value M (the noise cross-talk and the light signal reflected by the object 2) at this time is larger than the initial noise cross-talk value CT. Therefore, it is unnecessary to update the initial noise cross-talk value CT stored in the register. Then, the digital signal processing unit 2113 will subtract the initial noise cross-talk value CT from the specific measured value M to obtain the reflection light signal value N of the object 2.

[0242] Afterwards, in order to determine whether the object 2 is located in the detection range of the proximity sensor 2111, that is to say, to determine whether the object 2 is close enough to the proximity sensor 2111, the digital signal processing unit 2113 compares the reflection light signal value N of the object 2 with a default value NO to determine whether the reflection light signal value N of the object 2 is larger than the default value NO. It should be noted that the default value NO is the object detecting threshold value detected by the proximity sensor 2111 when the object 2 is located at the boundary SB of the detection range of the proximity sensor 2111.

[0243] If the result determined by the digital signal processing unit 2113 is yes, that is to say, the reflection light signal value N of the object 2 is larger than the default value NO, it means that the strength of the light reflected by the object 2, reflecting the light of the light-emitting diode LED, is stronger than the strength of the light reflected by the object located at the boundary SB of the detection range of the proximity sensor 2111, also reflecting the light of the light-emitting diode LED. Therefore, the proximity sensor 2111 knows that the object 2 is located in the detection range of the proximity sensor 2111; that is say; the object 2 is close enough to the proximity sensor 2111, as shown in FIG. 27(c) and FIG. 27(d). At this time, the buffer 2115 will output a proximity notification signal to inform the electronic apparatus, including the proximity sensor 2111, that the object 2 is approaching, so that the electronic apparatus can immediately make corresponding actions. For example, the electronic apparatus can shut down the touch function of its touch monitor.

[0244] If the result determined by the digital signal processing unit 2113 is no, that is to say, the reflection light signal value N of the object 2 is not larger than the default value NO, it means that the strength of the light reflected by the object 2, reflecting the light of the light-emitting diode LED, is not stronger than the strength of the light reflected by the object located at the boundary SB of the detection range of the

proximity sensor **2111**, reflecting the light of the light-emitting diode LED. Therefore, the proximity sensor **2111** knows that the object **2** is not located in the detection range of the proximity sensor **2111**; that is to say, the object **2** is not close enough to the proximity sensor **2111**, as shown in FIGS. **27(e)** and **27(f)**. Therefore, the buffer **2115** will not output the proximity notification signal to inform the electronic apparatus, including the proximity sensor **2111**, that the object **2** is approaching, and the electronic apparatus will not make corresponding actions such as shutting down the touch function of its touch monitor.

[**0245**] The third operation mode is a selection setting mode. The user can use the I2C interface **2114** to set a control bit for the user to freely choose between the manual setting mode and the automatic setting mode to reduce the effect of the noise crosstalk.

[**0246**] Another preferred embodiment of the invention is a proximity sensor operating method. FIG. **28** illustrates a flowchart of the proximity sensor operating method in this embodiment.

[**0247**] As shown in FIG. **28**, in the step **S30**, the method detects whether an object is close by to the proximity sensor to obtain a measured value. Then, in the step **S32**, the method compares the measured value with an initial noise cross-talk value to determine whether the initial noise cross-talk value should be updated. Wherein, the initial noise cross-talk value is obtained by the proximity sensor operated under the manual setting mode. Under the manual setting mode, the proximity sensor obtains a first measured value when the light emitter is active and a second measured value when the light emitter is inactive, and subtracts the second measured value from the first measured value to obtain an initial noise cross-talk value.

[**0248**] If the result determined by the step **S32** is yes, the method will perform the step **S34**, not to update the initial noise cross-talk value. If the result determined by the step **S32** is no, the method will perform the step **S36** to compare the measured value with a default value to determine whether the object is located in a detection range of the proximity sensor. Wherein, the default value is the object detecting threshold value detected by the proximity sensor when the object is located at the boundary of the detection range of the proximity sensor.

[**0249**] If the result determined by the step **S36** is yes, the method will perform the step **S38** to determine that the object is located in the detection range of the proximity sensor. If the result determined by the step **S36** is no, the method will perform the step **S39** to determine that the object is not located in the detection range of the proximity sensor.

[**0250**] FIGS. **29(a)** and **(b)** illustrate flowcharts of the proximity sensor operating method in another embodiment. As shown in FIGS. **29(a)** and **(b)**, in the step **S40**, the method selects either the manual setting mode or the automatic setting mode to operate the proximity sensor. If the manual setting mode is selected, under the condition that no object is close by to the proximity sensor of the electronic apparatus, the method performs the step **S41** to detect a first measured value **C1** when the LED is active and emit lights and the step **S42** to detect a second measured value **C2** when the LED is inactive.

[**0251**] Since the second measured value **C2** may include noise and the first measured value **C1** may include noise and noise cross-talk, in the step **S43**, the method subtracts the second measured value **C2** from the first measured value **C1**

to obtain an initial noise cross-talk value **CT** and store the initial noise cross-talk value **CT** in a register, and the initial noise cross-talk value **CT** is used as a maximum threshold value of noise cross-talk in the system.

[**0252**] If the automatic setting mode is used, after the electronic apparatus, including the proximity sensor, is active, the object may be close to the proximity sensor of the electronic apparatus. The method performs the step **S44** to detect a third measured value **C3** when the LED is active and emit lights and the step **S45** to detect a fourth measured value **C4** when the LED is inactive. Since the fourth measured value **C4** may include the noise, and the third measured value **C3** may include the noise, the noise cross-talk, and the light signal reflected by the object. Therefore, in the step **S46**, the method obtains a specific measured value **M** by subtracting the fourth measured value **C4** from the third measured value **C3**, and the specific measured value **M** represents the noise cross-talk and the light signal reflected by the object.

[**0253**] In step **S47** the method determines whether the specific measured value **M** is larger than the initial noise cross-talk value **CT**. If the result determined by the step **S47** is no, it means that the specific measured value **M** (the noise cross-talk and the light signal reflected by the object **2**) at this time is smaller than the initial noise cross-talk value **CT**. Therefore, in the step **S48**, the method uses the specific measured value **M** to replace the initial noise cross-talk value **CT**; so that the specific measured value **M** can be used as an updated initial noise cross-talk value. Later, when the method performs the step **S47** again, the updated initial noise cross-talk value (the specific measured value **M**) will be used to compare with another specific measured value **M'** obtained by the method performing the step **S46** again to determine whether the specific measured value **M'** is larger than the updated initial noise cross-talk value (the specific measured value **M**).

[**0254**] If the result determined by the step **S47** is yes, it means that the specific measured value **M** (the noise cross-talk and the light signal reflected by the object) at this time is larger than the initial noise cross-talk value **CT**. Therefore, it is unnecessary to update the initial noise cross-talk value **CT** stored in the register. In the step **S50**, the method will subtract the initial noise cross-talk value **CT** from the specific measured value **M** to obtain the reflection light signal value **N** of the object.

[**0255**] Afterwards, in order to determine whether the object is located in the detection range of the proximity sensor; that is to say, to determine whether the object is close enough to the proximity sensor, in the step **S51**, the method will compare the reflection light signal value **N** of the object with a default value **NO** to determine whether the reflection light signal value **N** of the object is larger than the default value **NO**. It should be noted that the default value **NO** is the object detecting threshold value detected by the proximity sensor when the object is located at the boundary of the detection range of the proximity sensor.

[**0256**] If the result determined by the step **S51** is yes, that is to say, the reflection light signal value **N** of the object is larger than the default value **NO**, it means that the strength of the reflected light generated by the object reflecting the light of the LED is stronger than the strength of the reflected light generated by the strength of the reflected light generated by the object located at the boundary of the detection range of the proximity sensor reflecting the light of the LED. Therefore, in the step **S52**, the method determines that the object is located in the detection range of the proximity sensor; that is say, the

object is close enough to the proximity sensor. At this time, the proximity sensor will output a proximity notification signal to inform the electronic apparatus that the object is approaching, so that the electronic apparatus can immediately make corresponding action.

[0257] If the result determined by the step S51 is no, that is to say, the reflection light signal value N of the object is not larger than the default value N0, it means that the strength of the light reflected by the object, reflecting the light of the LED, is not stronger than the strength of the light reflected by the object located at the boundary of the detection range of the proximity sensor, also reflecting the light of the LED. Therefore, in the step S53, the method determines that the object is not located in the detection range of the proximity sensor; that is to say, the object is not close enough to the proximity sensor. Therefore, the buffer will not output the proximity notification signal to inform the electronic apparatus that the object is approaching.

#### Particle Detection

[0258] FIG. 30 is a schematic view showing a configuration of a particle detector according in one embodiment. An apparatus 2210 has a chamber 2212 surrounded by a wall 2211, and the chamber 2212 has an inlet 2213 for taking air from the outside and an outlet 2214 for discharging air. In order to take air and generate airflow at a particle detection position as later described, an airflow generating/controlling device 2215 is provided on the inner side of the inlet 2213. Even when the airflow generating/controlling device 2215 is not turned on, air can flow between the inlet 2213 and outlet 2214.

[0259] As the airflow generating/controlling device 2215, a small fan is typically used. However, in order to generate airflow in a rising direction opposite to the gravity, an air heating device such as a heater may be used. Air entered from the inlet 2213 into the chamber 2212 passes through the inside of the chamber 2212 and is guided to the outlet 2214. Though not shown, airflow guide means having, for example, a cylindrical shape may be provided between the inlet 2213 and the outlet 2214. Further, a filter may be installed at a prior stage to the airflow generating/controlling device 2215 to prevent the entry of particles having a size greater than target fine particles.

[0260] The apparatus 2210 also includes means for detecting a particle. That means includes a light source 2220 and a detection device 2230. In this embodiment, the light source 2220 and the detection device 2230 are arranged horizontally in an opposing manner. This allows the detection device 2230 to directly receive light from the light source 2220, and the light source 2220 and the detection device 2230 are configured to pass the airflow generated by the airflow generating/controlling device 2215 between them.

[0261] The light source 2220 is composed of a light-emitting element 2221 and an optical system 2222 including a lens. The light-emitting element 2221 may be typically composed of a semiconductor light-emitting element such as a laser diode or a light-emitting diode capable of emitting coherent light. If the degree of sensitivity is not pursued, other light-emitting element may be used. However, a light-emitting element capable of emitting light with a certain degree of directional characteristics is desired from the viewpoint of device design.

[0262] On the other hand, the detection device 2230 is composed of a photodetector 2231 and an optical system 2232 including a lens. As the photodetector 2231, an image

sensor such as a CMOS image sensor or a CCD image sensor may be used. The photodetector 2231 is configured so as to output a detection signal to an external analyzer 2240.

[0263] Light emitted from the light emitting-element 2221 passes through the optical system 2222, and is illuminated to a gas to be measured. In one embodiment, light emitted from the light emitting-element 21 is substantially collimated by the optical system 2222. The light passing through the gas in the measurement area is collected by the optical system 2232 in the detection device 2230, and detected as an image by an image sensor 31. The image sensor 31 outputs a signal of the image to the analyzer 2240.

[0264] Optical dimensions of the lens in the optical system 2222, such as a focal length, can be determined based on a radiation angle of light from the light-emitting element 2221 and a diameter of fine particles to be measured. Specifically, it is necessary to select a focal length of the lens so that a light flux has a diameter several times larger than the size of the fine particles to be measured. For example, in measuring fine particles having a size of approximately 100 micrometers, it is necessary to illuminate light in such a way that the light has a diameter of not less than several hundred micrometers, so as to keep the sensitivity of the entire system. However, if light is illuminated to a large area, the power of transmitted light to be detected decreases, resulting in a degraded signal/noise ratio. Therefore, optimization may be necessary.

[0265] FIG. 31 is a time chart showing the timing of the operation of the light emitting-element and the exposure of the image sensor. The light emitting-element 2221 such as a laser diode is made to generate light pulses rather than continuous light (CW) for the purpose of reducing power consumption. The cycle (T) of a light pulse and a time period ( $\Delta T$ ) for illumination are properly selected from the moving speed of fine particles to be measured. If the cycle T is too long, problems may arise that, for example, fine particles themselves may not be detected or a captured image becomes blurred. If the cycle T is too short, the light application time  $\Delta T$  is also short and thus there is a drawback that the signal/noise ratio is degraded.

[0266] In FIG. 30, the exposure time of the image sensor 2231 is the same as that of the light emitting-element 2221. This period is optimized by taking into consideration the signal/noise ratio of the entire system. The number of pixels of the image sensor mainly depends upon the size of fine particles to be measured. If the size of fine particles to be measured is from 1 micrometer to 100 micrometers, the number of pixels may be approximately 10,000.

[0267] Hereafter, an algorithm for detecting smoke particles, dust and pollen will be described. This method is not limited to the present embodiment, any may be applied to apparatus according to second and third embodiments described later.

[0268] Here, an output taken by the image sensor along x-axis (i-th) and y-axis (j-th) is indicated as  $V(i,j)$ . Depending on the configuration of a focal length of a lens, there may be a difference in an output of the image sensor per pixel. Therefore, calibration is carried out at the beginning to adjust all of the pixels so that offset and sensitivity fall within a certain range. This adjustment may be carried out by hardware means or software means. In the following description,  $V(i,j)$  is an output value after the adjustment is carried out.

[0269] First, a state without the presence of obstacles, such as smoke particles, dust and pollen, is considered. In this case, transmitted light is detected directly by the image sensor

without scattering, and thus its output  $V_{\text{non}}(i,j)$  has a very small variance  $\sigma_{\text{non}}$  for the entire pixels.

**[0270]** When any of fine particles such as smoke particles, dust or pollen is entered, light is scattered thereby, resulting in a reduction in an amount of transmitted light. This enables to detect the fine particles. A predetermined value  $V_{\text{noise}}$  is set by taking into accounts the stability of LD inside the detection apparatus, shot noises which may occur in the image sensor, noises in amplifier circuitry, and thermal noises. If this value is exceeded, it is determined that a signal is supplied. While the fine particles may be introduced by generating airflow, natural diffusion or natural introduction of particles may be utilized without generating the airflow.

**[0271]** When it is determined that a signal is supplied, smoke particles, dust and pollen are distinguished in accordance with the following procedure.

**[0272]** 1. When it is determined that a signal is supplied to all of the pixels, that is determined to be attributable to smoke particles. In other words, when

$$V(i,j) < V_{\text{non}} - V_{\text{detect-1}}$$

**[0273]** is valid for all of the pixels, smoke particles are identified. Here,  $V_{\text{detect-1}}$  is a constant threshold larger than  $V_{\text{noise}}$ . Even if very large particles are introduced, the signal is detected in all of the pixels. However, as stated previously, in this case, such particles are removed in advance by a filter. Further, a concentration of the smoke is identified depending on an intensity of the signal.

**[0274]** 2. When part of pixels have responded, dust or pollen is identified. Binarization is carried out to identify a portion shielded by fine particles. FIG. 28 is a view schematically showing such binarization. For example, if a dust has a size and shape as shown in (a), that is identified by binarization as an image as shown in (b).  $V_{\text{detect-2}}$  are used as a parameter for performing the binarization, and pixels that output a signal exceeding this threshold  $V_{\text{detect-2}}$  are counted. The count number is proportional to a light-shielding cross-sectional area by the fine particles, with respect to the incident light. On the basis of the counted pixel number, fine particles of 20 micrometers or less or 50 micrometers or more are identified as dust.

**[0275]** 3. When the result of the above size measurement of the fine particles indicates that the particles are determined to have a size from 20 micrometer to 50 micrometer, it is possible that the particles are pollen. Therefore, in such a case, determination by a further method is necessary. In general, since dust is lighter than pollen, dust has a higher moving speed in airflow than pollen. Therefore, the moving speed of floating particles is calculated. When the moving speed of the particles is at a predetermined level or higher, those particles are determined to be dust, and otherwise they are determined to be pollen. When the airflow is not rising and the fine particles flow from top to down, the particles having a higher moving speed is considered pollen and slow particles are considered dust.

**[0276]** The speed value is obtained by taking two images at successive units of time, and calculating from a moving distance between the images and a frame time.

**[0277]** FIGS. 32(a) and (b) are views showing schematized image information of a binarized particle image.

**[0278]** FIGS. 33(a) and (b) show temporal a change in a binarized image signal. In this example, it is recognized that a particle is moving upwardly. In order to recognize movement of particles from image information, a correlation value

conventionally used in related technology can be utilized. As a result of determining the moving speed, when it is not lower than or not higher than a predetermined speed, the particles can be identified as dust or pollen, respectively.

**[0279]** In this description, detection of fine particles such as dust and pollen has been mainly described. However, by improving the analytical algorithm of the present apparatus, it is possible to produce a histogram of passing particles over a certain period in terms of size or weight of fine particles contained in an introduced gas. From this result, it is possible to analyze what types of fine particles exist in a room or in the open air.

**[0280]** FIG. 35 is a view describing a modified embodiment of the photodetector. In the aforementioned embodiment, the image sensor as a photodetector is provided with detection elements in the form of a matrix of approximately  $100 \times 100$ . However, a photodetector is not necessarily provided with a matrix of detection elements, and a photodetector having detection elements 51 disposed in a striped form may be used. That is, in this apparatus, when airflow is generated, the moving direction of fine particles is considered to run along a direction of the airflow. Therefore, detection of particles as in the foregoing embodiment is possible, by utilizing a photodetector 2250 having a striped configuration wherein elongated detection elements 2251 are extended in a direction perpendicular to the moving direction of the fine particles.

**[0281]** FIGS. 34(a) and (b) show particle detection at different times when the photodetector 50 is used. In each figure, a positional relation between the photodetector and a particle is shown on the left and output values are shown on the right. FIG. 34(a) shows an initial state and FIG. 34(b) show a state after a predetermined time period after the state of FIG. 34(a). Each of the detection elements 2251 constituting a stripe can output a signal which is substantially proportional to the area of an image. Therefore, by establishing and comparing the output values, the position of a particle at that time and a particle moving speed may be determined. For example, when data obtained from the individual stripe-shaped light detection elements 2251 is processed using a spatial filter as in a sensing device, the size and the moving speed of the fine particle can be easily obtained. In this case, however, there is a certain tradeoff between the particle size and the moving speed.

**[0282]** This method can reduce an amount of data to be processed, compared with a case wherein an image sensor in the form of a matrix is used, and therefore this method is advantageous in that data processing can be performed more easily and rapidly.

**[0283]** FIG. 36 is a schematic view showing the configuration of a particle detection apparatus according to a second embodiment of the present invention. In the first embodiment, a particle detection apparatus utilizing transmitted light was described. However, with a method of measuring reflected light or scattered light as described in FIG. 6, it is possible to detect smoke particles, dust and pollen. The description of operation of each component is omitted by attaching thereto a reference numeral which is greater by 100 than the numeral reference of a corresponding component shown in FIG. 30.

**[0284]** Regarding the positional relation between a light source 2320 and a detection device 2330, they are disposed on opposite sides of airflow, but they are not necessarily disposed in such a way. For example, the light source and the detection device may be disposed on the same side of the airflow, and in that case, light from the light source may be illuminated from

either an upstream side or a downstream side of the airflow. Further, the light source and the detection device are disposed in a plane that is orthogonal to the airflow, and they may be disposed not linearly like that of FIG. 30, but in a tilted direction within the plane.

[0285] In the apparatus according to the first embodiment, as transmission light is always incident, it has to keep a certain level of an input range. As a result, measurements may not always be performed properly. In contrast, in accordance with the detection system of the second embodiment, a dynamic range of the image sensor of the apparatus can be utilized to advantage. Therefore, it is advantageously suitable for a high sensitive measurement of fine particles.

[0286] This apparatus is applicable to systems that detect fine particles including dust, pollen and smoke particles, such as an air cleaner, an air conditioner, a vacuum cleaner, an air fan, a fire alarm, a sensor for environmental measurement and a fine particle detection apparatus in a clean room.

#### Temperature Sensor

[0287] FIG. 36 is a block diagram illustrating an embodiment of the IR thermometer 2410. This embodiment includes an IR sensor package/assembly 2412, distance sensor 2414, a microprocessor 2416 and a memory 2418.

[0288] In one embodiment one or more sensors, which can be in an assembly 2412 includes a sensor. In one embodiment a sensor and a temperature sensor is provided. As a non-limiting example, the sensor can be an IR sensor. In one embodiment the sensor is an IR sensor. In one embodiment a temperature sensor senses the temperature of the sensor and/or the temperature of the ambient environment. The sensor is configured to capture thermal radiation emanating from a target object or target body part, e.g., a person's forehead, armpit, ear drum, etc., which is converted into an electrical temperature signal and communicated, along with a signal regarding the temperature of the sensor as measured by the temperature sensor, to microprocessor 2416, as is known in the art. Distance sensor 2414 is configured to emit radiation from IR thermometer 2410 and to capture at least a portion of the emitted radiation reflected from the target, which is converted into an electrical distance signal and communicated to microprocessor 2416. Microprocessor 2416 is configured to, among other things, determine a temperature value of the target based on the signal from sensor package/assembly 2412, determine an ambient environment or thermometer temperature, and to determine a distance value corresponding to the distance between thermometer 2410 and the target using a correlation routine based on the signal from distance sensor 2414 and the characteristics of the reflected radiation. In various embodiments, the temperature signal, distance signal, temperature value, distance value, or any combination thereof may be stored in memory 2418.

[0289] Memory 2418 includes therein predetermined compensation information. This predetermined compensation information may be empirically predetermined by performing clinical tests. These clinical tests may relate the detected temperature of a target (e.g., forehead), the distance of the thermometer from the target, as well as the actual temperature of the target and the ambient environment or thermometer temperature. These clinical tests may further relate the temperature of the target, either the detected temperature, the actual temperature, or both, to, e.g., an actual oral or oral-equivalent temperature. Accordingly, target temperatures of various persons having oral temperatures between, e.g., 94°

Fahrenheit to 108° Fahrenheit, may be measured using a thermometer at various known distances from the targets, e.g., from 0 centimeters (i.e., thermometer contacts target) to 1 meter, in increments of, e.g., 1 centimeter, 5 centimeters, or 10 centimeters. In some embodiments, the range of distances corresponds to a range of distances over which thermometer 2410 may be operational. Additionally, these measurements may be conducted in environments having various ambient temperatures between, e.g., 60° Fahrenheit to 90° Fahrenheit. These data may be used to create compensation information, such as a look-up table or mathematical function, whereby a compensated temperature of the target may subsequently be determined from a measured distance value, e.g., using distance sensor 2414, a measured target temperature value, e.g., using IR sensor package or assembly 2412, and, in some embodiments, an ambient environment temperature value and/or thermometer temperature value. In other embodiments, data relating to actual oral or oral-equivalent temperatures may be further used to create the compensation information, whereby a compensated oral or compensated oral-equivalent temperature may be determined from a measured distance value, a measured target temperature value, and, in some embodiments, an ambient environment temperature value and/or thermometer temperature value.

[0290] For example, where  $d$  is defined as a distance between the target and thermometer 2410, the predetermined compensation information for obtaining a compensated temperature in degrees Fahrenheit may be a linear function or functions defined by the following relationships:

$$\text{Compensated Temperature} = \text{Target Temperature} + A * d + B$$

Or

$$\text{Compensated Temperature} = \text{Target Temperature} + C * d + D \quad \{\text{for } 0 < d \leq Y\}, \text{ and}$$

$$\text{Compensated Temperature} = \text{Target Temperature} + E * d + F \quad \{\text{for } Y < d \leq Z\},$$

[0291] Where A, C, and E are coefficients having dimensions of Temperature/Length; B, D and F are coefficients having dimensions of Temperature; and Y and Z are distances from the target. Values of A, B, C, D, E, F, Y, and Z may be determined empirically from clinical tests. For purposes of illustration and not limitation, the following exemplary and approximate values for the coefficients and distances are provided: A=0.05, B=0.1, C=0.05, D=0.2, E=0.15, F=0.1, Y=15, and Z=30. However, as will be recognized by persons having ordinary skill in the art, other values for each coefficient and distance may be used depending on various design features and aspects of a thermometer 2410.

[0292] It is also possible for the mathematical function to be of a higher degree or order, for example, a mathematical function that is non-linear with respect to the measured distance to obtain the compensated temperature, such as the following quadratic equation:

$$\text{Compensated Temperature} = \text{Target Temperature} + G * d^2 - H * d + L$$

[0293] Where G, H, and L are coefficients determined from the clinical tests. For purposes of illustration and not limitation, the following exemplary and approximate values for the coefficients are provided: G=0.001, H=0.15, and L=0.1. However, as will be recognized by persons having ordinary

skill in the art, other values for each coefficient may be used depending on various design features and aspects of thermometer **2410**.

[0294] The compensation information may alternatively be provided as various offset values, whereby, for each distance increment or range of distances from the target surface, there is a corresponding offset value. In various embodiments, these offsets may be fixed for each of the distance increments or range of distances from the target surface. For example, in various embodiments, the offset value may be, e.g., any one of 0.1° F., 0.2° F., or 0.5° F. over a range of distances from the target surface such as 0 cm to 5 cm, 0 cm to 20 cm, or 5 cm to 30 cm. For example, in one embodiment, the offset value may be 0.0° F. from 0.0 cm to 0.1 cm, 0.1° F. from 0.1 cm to 3.0 cm, 0.2° F. from 3.0 cm to 15 cm, and 0.5° F. from 15.1 cm to 30 cm. Alternatively, the compensation information may be in the form of a single, e.g., “best-fit,” offset value that may be used to determine a compensated temperature from any of the target temperatures over a distance range, either the entire distance range recited above or a portion thereof. For example, the “best-fit” offset value may be, e.g., any one of 0.1° F., 0.2° F., or 0.5° F. For example, in one embodiment, the offset value may be 0.1° F. over the distance range from 0.0 cm to 10 cm, and 0.0° F. for greater distances. In other embodiments, the offset value may be 0.1° F. over the distance range from 0.0 cm to 30 cm, and 0.0° F. for distances greater than 30 cm.

[0295] In other embodiments, the compensation information may be in the form of a look-up table, which may be devised from predetermined information collected during clinical tests, such as actual target temperature, measured target temperature, ambient environment and/or thermometer temperature, and distance measurements, such that, subsequently, a compensated temperature may be determined by identifying in the look-up table those values that best correspond to the measured distance and measured target-temperature values. In the event of an imperfect match between the measured values and the table values, the closest table values may be used, or, additional values interpolated from the table values may be used. In other embodiments, the compensation information may include a combination of more than one of the approaches (e.g., mathematical function, offset value, look-up table) described above

[0296] Further, as noted above, the ambient environment temperature value and/or thermometer temperature value may be used in generating compensation information. It may be beneficial to include these values as factors in the compensation information because these values may increase the accuracy of a compensated temperature calculated based on the compensation information. For example, the above discussed mathematical functions may be modified based on ambient environment temperature and/or thermometer temperature. For example, a first “best fit” offset value (e.g., 0.1° F.) may be used when the ambient temperature is within a first range of temperatures (e.g., 60° F. to 75° F.), and a second “best fit” offset value (e.g., 0.2° F.) may be used when the ambient temperature is within a second range of temperatures (e.g., 75° F. and 90° F.).

[0297] Microprocessor **2416** is configured to use a temperature value corresponding to a target and a distance value corresponding to the distance between thermometer **2410** and the target to determine a compensated temperature using the predetermined compensation information stored in memory **2418**. In some embodiments, Microprocessor **2416** may be

further configured to use an ambient and/or thermometer temperature in this determination. In some embodiments, the predetermined compensation information may be based in part on ambient and/or thermometer temperature. In those embodiments where the predetermined compensation information includes predetermined information concerning oral or oral-equivalent temperatures, Microprocessor **2416** may be further configured to determine a compensated temperature corresponding to an oral or oral-equivalent temperature.

[0298] Microprocessor **2416** may further store one or more compensated temperature values in memory **2418**. In various embodiments, the microprocessor is further configured to interpolate additional values from any values stored in a look-up table in memory **2418**.

[0299] Referring to FIG. **37**, the flow chart shows an embodiment of a method for determining a compensated temperature based on a measured temperature of a target on that person, e.g., that person’s forehead. In step **2502**, the process for determining the compensated temperature starts, e.g., by the user depressing a start button to, e.g., activate thermometer **2410**. In step **2504**, distance sensor **2414** is used to emit radiation and capture reflected radiation from a target to generate a distance signal, which is communicated to microprocessor **2416**. Microprocessor **2416** determines a distance value from the distance signal, which microprocessor **2416** may store in memory **2418**. In step **2506**, sensor package/assembly **2412** is used to capture thermal radiation emanating from the target to generate a temperature signal, and, optionally, to capture an ambient and/or thermometer temperature, which are communicated to microprocessor **2416**. Microprocessor **2416** determines a temperature value from the temperature signal, which microprocessor **2416** may store in memory **2418**. In optional step **2508**, which is performed when the predetermined compensation information includes a look-up table, microprocessor **2416** determines a relationship between the distance value and the temperature values using predetermined compensation information. In step **2510** microprocessor **16** determines a compensated temperature value based on the predetermined compensation information. In step **2512**, microprocessor **2416** stores the compensated temperature in memory **2418**. In step **2514**, the compensated temperature value is communicated.

#### Humidity Sensor

[0300] Absolute humidity is the total amount of water vapor present in a given volume of air. It does not take temperature into consideration. Absolute humidity in the atmosphere ranges from near zero to roughly 30 grams per cubic meter when the air is saturated at 30° C.

[0301] Absolute humidity is the mass of the water vapor ( $m_w$ ), divided by the volume of the air and water vapor mixture ( $p_{net}$ ), which can be expressed as:

$$AH = \frac{m_w}{p_{net}}$$

[0302] The absolute humidity changes as air temperature or pressure changes. This makes it unsuitable for chemical engineering calculations, e.g. for clothes dryers, where temperature can vary considerably. As a result, absolute humidity in chemical engineering may refer to mass of water vapor per unit mass of dry air, also known as the mass mixing ratio (see

“specific humidity” below), which is better suited for heat and mass balance calculations. Mass of water per unit volume as in the equation above is also defined as volumetric humidity. Because of the potential confusion, British Standard BS 1339 (revised 2002) suggests avoiding the term “absolute humidity”. Units should always be carefully checked. Many humidity charts are given in g/kg or kg/kg, but any mass units may be used.

**[0303]** The field concerned with the study of physical and thermodynamic properties of gas—vapor mixtures is named psychrometrics.

**[0304]** The relative humidity ( $\phi$ ) of an air-water mixture is defined as the ratio of the partial pressure of water vapor ( $H_2O$ ) ( $e_w$ ) in the mixture to the saturated vapor pressure of water ( $e_w^*$ ) at a given temperature. Thus the relative humidity of air is a function of both water content and temperature.

**[0305]** Relative humidity is normally expressed as a percentage and is calculated by using the following equation:

$$\phi = \frac{e_w}{e_w^*} \times 100\%$$

**[0306]** Relative humidity is an important metric used in weather forecasts and reports, as it is an indicator of the likelihood of precipitation, dew, or fog. In hot summer weather, a rise in relative humidity increases the apparent temperature to humans (and other animals) by hindering the evaporation of perspiration from the skin. For example, according to the Heat Index, a relative humidity of 75% at 80.0° F. (26.7° C.) would feel like 83.6° F.  $\pm$  1.3° F. (28.7° C.  $\pm$  0.7° C.) at ~44% relative humidity.

**[0307]** Specific Humidity:

**[0308]** Specific humidity (or moisture content) is the ratio of water vapor mass ( $m_v$ ) to the air parcel’s total (i.e., including dry) mass ( $m_a$ ) and is sometimes referred to as the humidity ratio. Specific humidity is approximately equal to the “mixing ratio”, which is defined as the ratio of the mass of water vapor in an air parcel to the mass of dry air for the same parcel.

**[0309]** Specific Humidity is defined as:

$$SH = \frac{m_v}{m_a}$$

**[0310]** Specific humidity can be expressed in other ways including:

$$SH = \frac{0.622 p_{(H_2O)}}{p_{(dry\ air)}}$$

$$0.622 = \frac{MM_{H_2O}}{MM_{dry\ air}}$$

or:

$$SH = \frac{0.622 p_{(H_2O)}}{p - 0.378 * p_{(H_2O)}}$$

**[0311]** Using this definition of specific humidity, the relative humidity can be expressed as

$$\phi = \frac{SH * p}{(0.622 + 0.378 * SH) p_{(H_2O)}} \times 100$$

**[0312]** However, specific humidity is also defined as the ratio of water vapor to the total mass of the system (dry air plus water vapor). For example, the ASHRAE 2009 Handbook defines specific humidity as “the ratio of the mass of water vapor to total mass of the moist air sample”.

**[0313]** Measurement

**[0314]** Various devices can be used to measure and regulate humidity. In one embodiment a psychrometer or hygrometer is used.

**[0315]** In one embodiment, illustrated in FIG. 42, a packaging is provided for the motion detection device 42 that includes a packaging magnet and the reed switch 90. The magnet activates the reed switch which keeps the motion detection device 42 in a low power mode. The low power mode preserves the motion detection device 42 battery life during storage and shipment. Once the user receives the packaging and removes the motion detection device 42 the reed switch 90 is deactivated (because it is no longer in close proximity to the magnet) and the motion detection device 42 is turned on. Simply removing the motion detection device 42 from its packaging is enough to deactivate the reed switch 90. No additional steps are needed. In one embodiment the distance between the packaging magnet and reed switch 90 is no greater than 2 mm, 1 mm, 0.5 mm, 0.4 mm, 0.3 mm, 0.2 mm, 0.1 mm and in a substantially adjacent relation. It can be as close as you want in transit. In one embodiment the packaging magnet has a Gauss. In one embodiment any kind of reed switch 90 can be used.

**[0316]** As illustrated in FIGS. 43 and 44, recording of the sound where at the location, preferably in a dwelling room environment, by monitoring device 42 is not always preserved. It is halted in response to motion sounds received from the person monitored. Recording via the microphone 18 is initiated but ceases in responses to signals received from the motion detection device 42 in order to provide privacy. The signals are low energy Bluetooth, the motion detection device 42, when it moves, or after it moves, it sends a signal to the monitoring device 42, which knows that the person moves and will cease recording. In one embodiment the system 10 has a database of classifications that provide for turn on and off in response to the signals. In one embodiment the system classifies the movement and determines desired to be preserved. The database can have a classifier to determine when to record and when not to for privacy concerns.

**[0317]** As a non-limiting example, one embodiment of a cloud system is illustrated in FIGS. 38(a)-38(e).

**[0318]** The cloud based system includes a third party service provider 120, that is provided by the methods used with the present invention, that can concurrently service requests from several clients without user perception of degraded computing performance as compared to conventional techniques where computational tasks can be performed upon a client or a server within a proprietary intranet. The third party service provider (e.g., “cloud”) supports a collection of hardware and/or software resources. The hardware and/or software resources can be maintained by an off-premises party, and the resources can be accessed and utilized by identified users over Network Systems. Resources provided by the third party service provider can be centrally located and/or distrib-

uted at various geographic locations. For example, the third party service provider can include any number of data center machines that provide resources. The data center machines can be utilized for storing/retrieving data, effectuating computational tasks, rendering graphical outputs, routing data, and so forth.

**[0319]** In one embodiment, the third party service provider can provide any number of resources such as servers, CPU's, data storage services, computational services, word processing services, electronic mail services, presentation services, spreadsheet services, web syndication services (e.g., subscribing to a RSS feed), and any other services or applications that are conventionally associated with personal computers and/or local servers. Further, utilization of any number of third party service providers similar to the third party service provider is contemplated. According to an illustration, disparate third party service providers can be maintained by differing off-premise parties and a user can employ, concurrently, at different times, and the like, all or a subset of the third party service providers.

**[0320]** By leveraging resources supported by the third party service provider 120, limitations commonly encountered with respect to hardware associated with clients and servers within proprietary intranets can be mitigated. Off-premise parties, instead of users of clients or network administrators of servers within proprietary intranets, can maintain, troubleshoot, replace and update the hardware resources. Further, for example, lengthy downtimes can be mitigated by the third party service provider utilizing redundant resources; thus, if a subset of the resources are being updated or replaced, the remainder of the resources can be utilized to service requests from users. According to this example, the resources can be modular in nature, and thus, resources can be added, removed, tested, modified, etc. while the remainder of the resources can support servicing user requests. Moreover, hardware resources supported by the third party service provider can encounter fewer constraints with respect to storage, processing power, security, bandwidth, redundancy, graphical display rendering capabilities, etc. as compared to conventional hardware associated with clients and servers within proprietary intranets.

**[0321]** The cloud based system can include a client device that employs resources of the third party service provider. Although one client device is depicted, it is to be appreciated that the cloud based system can include any number of client devices similar to the client device, and the plurality of client devices can concurrently utilize supported resources. By way of illustration, the client device can be a desktop device (e.g., personal computer), motion/movement/gesture detection device, and the like. Further, the client device can be an embedded system that can be physically limited, and hence, it can be beneficial to leverage resources of the third party service provider.

**[0322]** Resources can be shared amongst a plurality of client devices subscribing to the third party service provider. According to an illustration, one of the resources can be at least one central processing unit (CPU), where CPU cycles can be employed to effectuate computational tasks requested by the client device. Pursuant to this illustration, the client device can be allocated a subset of an overall total number of CPU cycles, while the remainder of the CPU cycles can be allocated to disparate client device(s). Additionally or alternatively, the subset of the overall total number of CPU cycles allocated to the client device can vary over time. Further, a

number of CPU cycles can be purchased by the user of the client device. In accordance with another example, the resources can include data store(s) that can be employed by the client device to retain data. The user employing the client device can have access to a portion of the data store(s) supported by the third party service provider, while access can be denied to remaining portions of the data store(s) (e.g., the data store(s) can selectively mask memory based upon user/device identity, permissions, and the like). It is contemplated that any additional types of resources can likewise be shared.

**[0323]** The third party service provider can further include an interface component that can receive input(s) from the client device and/or enable transferring a response to such input(s) to the client device (as well as perform similar communications with any disparate client devices). According to an example, the input(s) can be request(s), data, executable program(s), etc. For instance, request(s) from the client device can relate to effectuating a computational task, storing/retrieving data, rendering a user interface, and the like via employing one or more resources. Further, the interface component can obtain and/or transmit data over a network connection. According to an illustration, executable code can be received and/or sent by the interface component over the network connection. Pursuant to another example, a user (e.g. employing the client device) can issue commands via the interface component.

**[0324]** Moreover, the third party service provider includes a dynamic allocation component that apportions resources (e.g., hardware resource(s)) supported by the third party service provider to process and respond to the input(s) (e.g., request(s), data, executable program(s) and the like) obtained from the client device.

**[0325]** Although the interface component is depicted as being separate from the dynamic allocation component, it is contemplated that the dynamic allocation component can include the interface component or a portion thereof. The interface component can provide various adaptors, connectors, channels, communication paths, etc. to enable interaction with the dynamic allocation component.

**[0326]** FIGS. 39-41 illustrate one embodiment of a mobile device that can be used with the present invention.

**[0327]** The mobile or computing device can include a display that can be a touch sensitive display. The touch-sensitive display is sometimes called a "touch screen" for convenience, and may also be known as or called a touch-sensitive display system. The mobile or computing device may include a memory (which may include one or more computer readable storage mediums), a memory controller, one or more processing units (CPU's), a peripherals interface, Network Systems circuitry, including but not limited to RF circuitry, audio circuitry, a speaker, a microphone, an input/output (I/O) subsystem, other input or control devices, and an external port. The mobile or computing device may include one or more optical sensors. These components may communicate over one or more communication buses or signal lines.

**[0328]** It should be appreciated that the mobile or computing device is only one example of a portable multifunction mobile or computing device, and that the mobile or computing device may have more or fewer components than shown, may combine two or more components, or may have a different configuration or arrangement of the components. The various components may be implemented in hardware,

software or a combination of hardware and software, including one or more signal processing and/or application specific integrated circuits.

**[0329]** Memory may include high-speed random access memory and may also include non-volatile memory, such as one or more magnetic disk storage devices, flash memory devices, or other non-volatile solid-state memory devices. Access to memory by other components of the mobile or computing device, such as the CPU and the peripherals interface, may be controlled by the memory controller.

**[0330]** The peripherals interface couples the input and output peripherals of the device to the CPU and memory. The one or more processors run or execute various software programs and/or sets of instructions stored in memory to perform various functions for the mobile or computing device and to process data.

**[0331]** In some embodiments, the peripherals interface, the CPU, and the memory controller may be implemented on a single chip, such as a chip. In some other embodiments, they may be implemented on separate chips.

**[0332]** The Network System circuitry receives and sends signals, including but not limited to RF, also called electromagnetic signals. The Network System circuitry converts electrical signals to/from electromagnetic signals and communicates with communications Network Systems and other communications devices via the electromagnetic signals. The Network Systems circuitry may include well-known circuitry for performing these functions, including but not limited to an antenna system, an RF transceiver, one or more amplifiers, a tuner, one or more oscillators, a digital signal processor, a CODEC chipset, a subscriber identity module (SIM) card, memory, and so forth. The Network Systems circuitry may communicate with Network Systems and other devices by wireless communication.

**[0333]** The wireless communication may use any of a plurality of communications standards, protocols and technologies, including but not limited to Global System for Mobile Communications (GSM), Enhanced Data GSM Environment (EDGE), high-speed downlink packet access (HSDPA), wideband code division multiple access (W-CDMA), code division multiple access (CDMA), time division multiple access (TDMA), BLUETOOTH®, Wireless Fidelity (Wi-Fi) (e.g., IEEE 802.11a, IEEE 802.11b, IEEE 802.11g and/or IEEE 802.11n), voice over Internet Protocol (VoIP), Wi-MAX, a protocol for email (e.g., Internet message access protocol (IMAP) and/or post office protocol (POP)), instant messaging (e.g., extensible messaging and presence protocol (XMPP), Session Initiation Protocol for Instant Messaging and Presence Leveraging Extensions (SIMPLE), and/or Instant Messaging and Presence Service (IMPS)), and/or Short Message Service (SMS)), or any other suitable communication protocol, including communication protocols not yet developed as of the filing date of this document.

**[0334]** The audio circuitry, the speaker, and the microphone provide an audio interface between a user and the mobile or computing device. The audio circuitry receives audio data from the peripherals interface, converts the audio data to an electrical signal, and transmits the electrical signal to the speaker. The speaker converts the electrical signal to human-audible sound waves. The audio circuitry also receives electrical signals converted by the microphone from sound waves. The audio circuitry converts the electrical signal to audio data and transmits the audio data to the peripherals interface for processing. Audio data may be retrieved from and/or trans-

mitted to memory and/or the Network Systems circuitry by the peripherals interface. In some embodiments, the audio circuitry also includes a headset jack. The headset jack provides an interface between the audio circuitry and removable audio input/output peripherals, such as output-only headphones or a headset with both output (e.g., a headphone for one or both ears) and input (e.g., a microphone).

**[0335]** The I/O subsystem couples input/output peripherals on the mobile or computing device, such as the touch screen and other input/control devices, to the peripherals interface. The I/O subsystem may include a display controller and one or more input controllers for other input or control devices. The one or more input controllers receive/send electrical signals from/to other input or control devices. The other input/control devices may include physical buttons (e.g., push buttons, rocker buttons, etc.), dials, slider switches, and joysticks, click wheels, and so forth. In some alternate embodiments, input controller(s) may be coupled to any (or none) of the following: a keyboard, infrared port, USB port, and a pointer device such as a mouse. The one or more buttons may include an up/down button for volume control of the speaker and/or the microphone. The one or more buttons may include a push button. A quick press of the push button may disengage a lock of the touch screen or begin a process that uses gestures on the touch screen to unlock the device, as described in U.S. patent application Ser. No. 11/322,549, "Unlocking a Device by Performing Gestures on an Unlock Image," filed Dec. 23, 2005, which is hereby incorporated by reference in its entirety. A longer press of the push button may turn power to the mobile or computing device on or off. The user may be able to customize a functionality of one or more of the buttons. The touch screen is used to implement virtual or soft buttons and one or more soft keyboards.

**[0336]** The touch-sensitive touch screen provides an input interface and an output interface between the device and a user. The display controller receives and/or sends electrical signals from/to the touch screen. The touch screen displays visual output to the user. The visual output may include graphics, text, icons, video, and any combination thereof (collectively termed "graphics"). In some embodiments, some or all of the visual output may correspond to user-interface objects, further details of which are described below.

**[0337]** A touch screen has a touch-sensitive surface, sensor or set of sensors that accepts input from the user based on haptic and/or tactile contact. The touch screen and the display controller (along with any associated modules and/or sets of instructions in memory) detect contact (and any movement or breaking of the contact) on the touch screen and converts the detected contact into interaction with user-interface objects (e.g., one or more soft keys, icons, web pages or images) that are displayed on the touch screen. In an exemplary embodiment, a point of contact between a touch screen and the user corresponds to a finger of the user.

**[0338]** The touch screen may use LCD (liquid crystal display) technology, or LPD (light emitting polymer display) technology, although other display technologies may be used in other embodiments. The touch screen and the display controller may detect contact and any movement or breaking thereof using any of a plurality of touch sensing technologies now known or later developed, including but not limited to capacitive, resistive, infrared, and surface acoustic wave tech-

nologies, as well as other proximity sensor arrays or other elements for determining one or more points of contact with a touch screen.

**[0339]** A touch-sensitive display in some embodiments of the touch screen may be analogous to the multi-touch sensitive tablets described in the following U.S. Pat. No. 6,323,846 (Westerman et al.), U.S. Pat. No. 6,570,557 (Westerman et al.), and/or U.S. Pat. No. 6,677,932 (Westerman), and/or U.S. Patent Publication 2002/0015024A1, each of which is hereby incorporated by reference in their entirety. However, a touch screen displays visual output from the portable mobile or computing device, whereas touch sensitive tablets do not provide visual output.

**[0340]** A touch-sensitive display in some embodiments of the touch screen may be as described in the following applications: (1) U.S. patent application Ser. No. 11/381,313, "Multipoint Touch Surface Controller," filed May 12, 2006; (2) U.S. patent application Ser. No. 10/840,862, "Multipoint Touchscreen," filed May 6, 2004; (3) U.S. patent application Ser. No. 10/903,964, "Gestures For Touch Sensitive Input Devices," filed Jul. 30, 2004; (4) U.S. patent application Ser. No. 11/048,264, "Gestures For Touch Sensitive Input Devices," filed Jan. 31, 2005; (5) U.S. patent application Ser. No. 11/038,590, "Mode-Based Graphical User Interfaces For Touch Sensitive Input Devices," filed Jan. 18, 2005; (6) U.S. patent application Ser. No. 11/228,758, "Virtual Input Device Placement On A Touch Screen User Interface," filed Sep. 16, 2005; (7) U.S. patent application Ser. No. 11/228,700, "Operation Of A Computer With A Touch Screen Interface," filed Sep. 16, 2005; (8) U.S. patent application Ser. No. 11/228,737, "Activating Virtual Keys Of A Touch-Screen Virtual Keyboard," filed Sep. 16, 2005; and (9) U.S. patent application Ser. No. 11/367,749, "Multi-Functional Hand-Held Device," filed Mar. 3, 2006. All of these applications are incorporated by reference herein in their entirety.

**[0341]** The touch screen may have a resolution in excess of 1000 dpi. In an exemplary embodiment, the touch screen has a resolution of approximately 1060 dpi. The user may make contact with the touch screen using any suitable object or appendage, such as a stylus, a finger, and so forth. In some embodiments, the user interface is designed to work primarily with finger-based contacts and facial expressions, which are much less precise than stylus-based input due to the larger area of contact of a finger on the touch screen. In some embodiments, the device translates the rough finger-based input into a precise pointer/cursor position or command for performing the actions desired by the user.

**[0342]** In some embodiments, in addition to the touch screen, the mobile or computing device may include a touchpad (not shown) for activating or deactivating particular functions. In some embodiments, the touchpad is a touch-sensitive area of the device that, unlike the touch screen, does not display visual output. The touchpad may be a touch-sensitive surface that is separate from the touch screen or an extension of the touch-sensitive surface formed by the touch screen.

**[0343]** In some embodiments, the mobile or computing device may include a physical or virtual click wheel as an input control device. A user may navigate among and interact with one or more graphical objects (henceforth referred to as icons) displayed in the touch screen by rotating the click wheel or by moving a point of contact with the click wheel (e.g., where the amount of movement of the point of contact is measured by its angular displacement with respect to a center point of the click wheel). The click wheel may also be

used to select one or more of the displayed icons. For example, the user may press down on at least a portion of the click wheel or an associated button. User commands and navigation commands provided by the user via the click wheel may be processed by an input controller as well as one or more of the modules and/or sets of instructions in memory. For a virtual click wheel, the click wheel and click wheel controller may be part of the touch screen and the display controller, respectively. For a virtual click wheel, the click wheel may be either an opaque or semitransparent object that appears and disappears on the touch screen display in response to user interaction with the device. In some embodiments, a virtual click wheel is displayed on the touch screen of a portable multifunction device and operated by user contact with the touch screen.

**[0344]** The mobile or computing device also includes a power system for powering the various components. The power system may include a power management system, one or more power sources (e.g., battery, alternating current (AC)), a recharging system, a power failure detection circuit, a power converter or inverter, a power status indicator (e.g., a light-emitting diode (LED)) and any other components associated with the generation, management and distribution of power in portable devices.

**[0345]** The mobile or computing device may also include one or more sensors, including not limited to optical sensors. In one embodiment an optical sensor is coupled to an optical sensor controller in I/O subsystem. The optical sensor may include charge-coupled device (CCD) or complementary metal-oxide semiconductor (CMOS) phototransistors. The optical sensor receives light from the environment, projected through one or more lens, and converts the light to data representing an image. In conjunction with an imaging module (also called a camera module); the optical sensor may capture still images or video. In some embodiments, an optical sensor is located on the back of the mobile or computing device, opposite the touch screen display on the front of the device, so that the touch screen display may be used as a viewfinder for either still and/or video image acquisition. In some embodiments, an optical sensor is located on the front of the device so that the user's image may be obtained for videoconferencing while the user views the other video conference participants on the touch screen display. In some embodiments, the position of the optical sensor can be changed by the user (e.g., by rotating the lens and the sensor in the device housing) so that a single optical sensor may be used along with the touch screen display for both video conferencing and still and/or video image acquisition.

**[0346]** The mobile or computing device may also include one or more proximity sensors. In one embodiment, the proximity sensor is coupled to the peripherals interface. Alternately, the proximity sensor may be coupled to an input controller in the I/O subsystem. The proximity sensor may perform as described in U.S. patent application Ser. No. 11/241,839, "Proximity Detector In Handheld Device," filed Sep. 30, 2005; Ser. No. 11/240,788, "Proximity Detector In Handheld Device," filed Sep. 30, 2005; Ser. No. 13/096,386, "Using Ambient Light Sensor To Augment Proximity Sensor Output"; Ser. No. 13/096,386, "Automated Response To And Sensing Of User Activity In Portable Devices," filed Oct. 24, 2006; and Ser. No. 11/638,251, "Methods And Systems For Automatic Configuration Of Peripherals," which are hereby incorporated by reference in their entirety. In some embodiments, the proximity sensor turns off and disables the touch

screen when the multifunction device is placed near the user's ear (e.g., when the user is making a phone call). In some embodiments, the proximity sensor keeps the screen off when the device is in the user's pocket, purse, or other dark area to prevent unnecessary battery drainage when the device is a locked state.

**[0347]** In some embodiments, the software components stored in memory may include an operating system, a communication module (or set of instructions), a contact/motion module (or set of instructions), a graphics module (or set of instructions), a text input module (or set of instructions), a Global Positioning System (GPS) module (or set of instructions), and applications (or set of instructions).

**[0348]** The operating system (e.g., Darwin, RTXC, LINUX, UNIX, OS X, WINDOWS, or an embedded operating system such as VxWorks) includes various software components and/or drivers for controlling and managing general system tasks (e.g., memory management, storage device control, power management, etc.) and facilitates communication between various hardware and software components.

**[0349]** The communication module facilitates communication with other devices over one or more external ports and also includes various software components for handling data received by the Network Systems circuitry and/or the external port. The external port (e.g., Universal Serial Bus (USB), FIREWIRE, etc.) is adapted for coupling directly to other devices or indirectly over Network System. In some embodiments, the external port is a multi-pin (e.g., 30-pin) connector that is the same as, or similar to and/or compatible with the 30-pin connector used on iPod (trademark of Apple Computer, Inc.) devices.

**[0350]** The contact/motion module may detect contact with the touch screen (in conjunction with the display controller) and other touch sensitive devices (e.g., a touchpad or physical click wheel). The contact/motion module includes various software components for performing various operations related to detection of contact, such as determining if contact has occurred, determining if there is movement of the contact and tracking the movement across the touch screen, and determining if the contact has been broken (i.e., if the contact has ceased). Determining movement of the point of contact may include determining speed (magnitude), velocity (magnitude and direction), and/or an acceleration (a change in magnitude and/or direction) of the point of contact. These operations may be applied to single contacts (e.g., one finger contacts) or to multiple simultaneous contacts (e.g., "multitouch"/multiple finger contacts). In some embodiments, the contact/motion module and the display controller also detect contact on a touchpad. In some embodiments, the contact/motion module and the controller detects contact on a click wheel.

**[0351]** Examples of other applications that may be stored in memory include other word processing applications, JAVA-enabled applications, encryption, digital rights management, voice recognition, and voice replication.

**[0352]** In conjunction with touch screen, display controller, contact module, graphics module, and text input module, a contacts module may be used to manage an address book or contact list, including: adding name(s) to the address book; deleting name(s) from the address book; associating telephone number(s), e-mail address(es), physical address(es) or other information with a name; associating an image with a name; categorizing and sorting names; providing telephone

numbers or e-mail addresses to initiate and/or facilitate communications by telephone, video conference, e-mail, or IM; and so forth.

**[0353]** In one embodiment a caffeine database is included. In one embodiment a person's genetic information is used.

**[0354]** In one embodiment the caffeine database is included as part of the motion pattern database **2040**.

**[0355]** The system provides people with information regarding their caffeine intake and its effect on the person's sleep and sleep parameters.

**[0356]** In one embodiment caffeine intake is measured. The person's identify, gender, height, weight, sensitivity to caffeine, and goal bed time is included in a database as well the caffeine intake. Coffee, tea, energy drinks, or another caffeinated beverage in are in app and tell users where they fall on a scale of "Edgy," "Wired," and "Sleep Ready."

**[0357]** In one embodiment the person receives information from the system, which can be in the form of an app, the amount of sleep, type of sleep, and other sleep related information, as described above. The app can also provide the preceding information based on caffeine intake.

**[0358]** In one embodiment people use daily diary forms to record their daily caffeinated coffee intake and other lifestyle and health items, including the number of cigarettes smoked. No other caffeinated foods or beverages were recorded on the daily diary.

**[0359]** This information is stored in the database, and a caffeine profile in a database is created for each person.

**[0360]** In one embodiment the caffeine profile contains individual caffeine related effects on a user's sleep and knows when the user has had too much caffeine. In one embodiment, the database is in communication with the user to indicate the amount of caffeine, how it affects sleep, the nature of the sleep, and other parameters. The user can also be in communication with the database.

**[0361]** In one embodiment caffeine sensitivity is determined by the efficiency of the human body to process and metabolize caffeine. This is distinguished with caffeine tolerance, which describes how the body responds to caffeine over time.

**[0362]** Sensitivity has more to do with a person's unique genetic makeup as this determines to what degree a given amount of caffeine will affect a person.

**[0363]** In one embodiment the caffeine database includes a person's genetic profile relative to gene variants as they pertain to the person's response to caffeine, including but not limited to caffeine metabolism.

**[0364]** In one embodiment gene variants, POR and ABCG2, are applied to caffeine metabolism, as well as two others, BDNF and SLC6A4, that impact how caffeine triggers the body's sense of reward.

**[0365]** Caffeine is metabolized by the liver using the enzyme CYP1A2. The ability to produce this enzyme is regulated by the CYP1A2 gene. Slight changes in the DNA sequence of this gene determine how efficiently a person can metabolize caffeine and thus eliminate it from the body.

**[0366]** In one embodiment the AHR gene plays a role in caffeine sensitivity in that it regulates the turning on and off of the CYP1A2 gene.

**[0367]** In one embodiment caffeine sensitivity involves the type of adenosine receptors a person has in his/her brain. Those lacking the correct adenosine receptors in their brain are unresponsive to the awakening effects of caffeine because the caffeine molecule cannot properly bind to the receptors.

**[0368]** There can be six genetic variants associated with the way people metabolize and form addiction to caffeine. Whether coffee makes a person anxious or helps boost their memory is directly related to their DNA

**[0369]** The genetic variants associated are: (i) near genes CYP1A2 (cytochrome P450 1A2, responsible for about 95 per cent of caffeine metabolism in humans); (ii) AHR (aryl hydrocarbon receptor, that play a regulatory role in expression of target genes, including CYP1A1 and CYP1A2); (iii) AHR; (iv) CYP1A2; (v) variants near genes BDNF and SLC6A4; and (vi) variants near genes GCKR and MLXIPL.

**[0370]** A caffeine database can be included as follows:

Name	Ounces	Caffeine (mg)	mg/oz
7-Up	12	0	0.00
A&W Creme Soda	12	29	2.42
Afri Cola	12	100	8.33
Arizona Green Tea	16	40	2.50
Barq's Root Beer	12	22	1.83
Bawls	10	67	6.70
Beaver Buzz	8.4	110	13.10
Big Red	12	38	3.17
Boo-Koo Energy	24	120	5.00
BuzzWater	16.9	200	11.83
Cherry Coke	12	34	2.83
Cherry RC Cola	12	43.2	3.60
Chocolate Milk	8	5	0.63
Coca-Cola Blak	12	68	5.67
Coca-Cola C2	12	34	2.83
Coca-Cola Classic	12	34	2.83
Coca-Cola Zero	12	34.5	2.88
Coffee (Brewed)	8	107.5	13.44
Coffee (Decaf, Brewed)	8	3.5	0.44
Coffee (Decaf, Instant)	8	2.5	0.31
Coffee (Drip)	8	145	18.13
Coffee (Instant)	8	115	14.38
Cool from Nestea	12	16	1.33
Diet A&W Creme Soda	12	22	1.83
Diet Cherry Coca-Cola	12	34	2.83
Diet Coke	12	45	3.75
Diet Coke with Lemon	12	45	3.75
Diet Coke with Lime	12	45	3.75
Diet Coke with Splenda	12	34	2.83
Diet Cool from Nestea	12	11	0.92
Diet Dr Pepper	12	41	3.42
Diet Mello Yello	12	51	4.25
Diet Mountain Dew	12	55	4.58
Diet Mr. Pibb	12	40	3.33
Diet Pepsi-Cola	12	36	3.00
Diet Ruby Red Squirt	12	39	3.25
Diet Sun Drop	12	69	5.75
Diet Sunkist Orange Soda	12	42	3.50
Diet Vanilla Coke	12	45	3.75
Diet Wild Cherry Pepsi	12	36	3.00
Dr Nehi	12	42	3.50
Dr Pepper	12	41	3.42
Espresso	2	100	50.00
Full Throttle	16	141	8.81
Hot Cocoa	8	14	1.75
IBC Cherry Cola	12	23	1.92
Java Chai	8	60	7.50
Java Water	16.9	88.8	5.25
Jolt Cola	12	72	6.00
Josta	12	58	4.83
KMX Blue	8.4	53	6.31
KMX Orange	8.4	75	8.93
Lipton Brisk (all varieties)	12	9	0.75
MDX	14	82.25	5.88
MDX, Diet	14	87.5	6.25
Mello Yello	12	51	4.25
Monster	16	140	8.75
Mountain Dew	12	55	4.58
Mountain Dew Amp	8.4	75	8.93
Mountain Dew Code Red	12	55	4.58

-continued

Name	Ounces	Caffeine (mg)	mg/oz
Mr. Pibb	12	40	3.33
Mr. Pibb (Sugar Free)	12	58.8	4.90
Nehi Wild Red Soda	12	50.1	4.17
Nestea Diet Lemon Iced Tea	12	16	1.33
Nestea Lemon Iced Tea	12	16	1.33
Nestea Peach Iced Tea	12	16	1.33
Nestea Raspberry Iced Tea	12	16	1.33
Nestea Sweet Iced Tea	12	26	2.17
Nestea Unsweetened Iced Tea	12	26	2.17
No Fear	16	150	9.38
Oregon Chai (Concentrate)	8	32.5	4.06
Pacific Chai	12	100	8.33
Pepsi Edge	12	38	3.17
Pepsi One	12	55	4.58
Pepsi-Cola	12	38	3.17
Pibb Zero	12	40	3.33
Pimp Juice	8	100	12.50
RC Edge	12	70.2	5.85
Red Bull	8.3	80	9.64
Red Flash	12	40	3.33
Rockstar	16	150	9.38
Royal Crown Cola	12	43.2	3.60
Royal Crown Kick	12	57.6	4.80
Ruby Red Squirt	12	39	3.25
Sky Rocket Caffeinated Syrup	1	100	100.00
Slim-Fast Cappuccino Delight Shake	12	40	3.33
Snapple Decaffeinated Lemon Tea	12	4.5	0.38
Snapple Diet Lemon Tea	12	31.5	2.63
Snapple Diet Peach Tea	12	31.5	2.63
Snapple Diet Raspberry Tea	12	31.5	2.63
Snapple Diet Sun Tea	12	7.5	0.63
Snapple Ginseng Tea	12	7.5	0.63
Snapple Green Tea with Lemon	12	24	2.00
Snapple Lemon Tea	12	31.5	2.63
Snapple Lemonade Iced Tea	12	13.5	1.13
Snapple Lightning (Black Tea)	12	21	1.75
Snapple Mint Tea	12	31.5	2.63
Snapple Moon (Green Tea)	12	18	1.50
Snapple Peach Tea	12	31.5	2.63
Snapple Raspberry Tea	12	31.5	2.63
Snapple Sun Tea	12	7.5	0.63
Snapple Sweet Tea	12	12	1.00
SoBe Adrenaline Rush	8.3	79	9.52
Sprite	12	0	0.00
Starbucks Double Shot	6.5	120	18.46
Starbucks Grande Caffè	16	105	6.56
Americano			
Starbucks Grande Caffè Latte	16	70	4.38
Starbucks Grande Caffè Mocha	16	70	4.38
Starbucks Grande Cappuccino	16	70	4.38
Starbucks Grande Coffee	16	500	31.25
Starbucks Grande Decaf Coffee	16	10	0.63
Starbucks Short Caffè	8	35	4.38
Americano			
Starbucks Short Caffè Latte	8	35	4.38
Starbucks Short Caffè Mocha	8	35	4.38
Starbucks Short Cappuccino	8	35	4.38
Starbucks Short Coffee	8	250	31.25
Starbucks Short Decaf Coffee	8	10	1.25
Starbucks Tall Caffè	12	70	5.83
Americano			
Starbucks Tall Caffè Latte	12	35	2.92
Starbucks Tall Caffè Mocha	12	35	2.92
Starbucks Tall Cappuccino	12	35	2.92
Starbucks Tall Coffee	12	375	31.25
Starbucks Tall Decaf Coffee	12	10	0.83
Starbucks Via		130-140	
Starbucks Via Refreshers		45-55	
Sun Drop Cherry	12	64	5.33
Sun Drop Regular	12	63	5.25
Sunkist Orange Soda	12	41	3.42
Surge	12	51	4.25

-continued

Name	Ounces	Caffeine (mg)	mg/oz
TAB	12	45	3.75
Tea (Brewed, Imported)	8	60	7.50
Tea (Brewed, US Brands)	8	30	3.75
Tea (Green)	8	15	1.88
Tea (Iced)	8	47	5.88
Tea (Instant)	8	30	3.75
Vanilla Coke	12	34	2.83
Vault	12	70	5.83
Wild Cherry Pepsi	12	38	3.17
Wired X294	16	294	18.38
XS	8.4	85	10.12
XTZ Chai	12	154	12.83

**[0371]** Two loci are associated with habitual caffeine consumption: the first near AHR and the second between CYP1A1 and CYP1A2. CYP1A2 metabolizes caffeine and AHR regulates CYP1A2.

**[0372]** Genetic association studies have been directed to genes related to the pharmacokinetic and pharmacodynamic properties of caffeine and have identified genes encoding cytochrome P-450 (CYP)1A2, as the primary enzyme involved in caffeine metabolism.

**[0373]** There is a significant gene-based association (Bonferroni corrected for the total number of human genes) between CYP2C9 (P=0.023), and ADORA2A (P=0.011) and caffeine intake in addition to CYP1A2 and AHR (Table 4).

**[0374]** CYP1A2 at 15q24 and AHR at 7p21 are genes for caffeine intake. At plasma concentrations typical of humans (<100 μM), caffeine is predominantly (>95% of a dose) metabolized by CYP1A2 via N1-, N3-, and N7-demethylation to its three dimethylxanthines, namely, theobromine, paraxanthine, and theophylline, respectively. CYP1A2 expression and activity vary 10- to 60-fold between individual. Human CYP1A2 is located immediately adjacent to CYP1A1 in reverse orientation and the two genes share a common 5'-flanking region. At least 15 AHR response elements (AHRE) reside in this bidirectional promoter region and rs2470893 is located in AHRE6 (originally reported as AHRE5) which correlates with transcriptional activation of both CYP1A1 and CYP1A2. CYP1A1 expression in the liver (the target tissue for caffeine metabolism) is low and there is little evidence that this enzyme contributes to caffeine metabolism. This contrasts with the tissue specific expression of CYP1A2 in the liver.

**[0375]** Variation in CYP1A2 gene expression affects caffeine intake. The protein product of AHR, AhR, is a ligand-activated transcription factor that, upon binding, partners with ARNT and translocates to the nucleus where it regulates the expression of a number of genes including CYP1A1 and CYP1A2. There is marked variation in AhR binding affinity across populations. Variation in AHR expression has a key role in propensity to consume caffeine. An interaction between CYP1A2 and AHR is possible

**[0376]** There can be significant gene-based associations between CYP2C9 and ADORA2A and caffeine intake in addition to CYP1A2 and AHR. CYP2C9 catalyzes the N7-demethylation and C8-hydroxylation of caffeine to theophylline and 1,3,7-trimethyluric acid (a minor metabolite), respectively; but its role relative to CYP1A2 is generally small. In amounts typically consumed from dietary sources, caffeine antagonizes the actions of adenosine at the adenosine A2A receptor (ADORA2A), which plays an important role in

the stimulating and reinforcing properties of caffeine. Polymorphisms of ADORA2A have been previously implicated in caffeine-induced anxiety as well as habitual caffeine intake.

**[0377]** Caffeine intake has been associated with pleiotropic physiologic effects in relation to both detrimental and beneficial health outcomes.

**[0378]** In various embodiments, the system 10 is used to detect a person's level of snoring. In one embodiment the system detects a vibration of respiratory structures. In one embodiment the vibration results in snoring sounds. In one embodiment the vibration results in sound due to obstructed air movement during breathing while sleeping. In one embodiment sound is soft and another it is loud. In one embodiment the detected snoring sounds is a factor of sleep deprivation. In one embodiment the snoring causes sleep deprivation. In one embodiment the snoring is indicative of sleep deprivation.

**[0379]** In one embodiment the snoring is indication of heart disease. In one embodiment the snoring is indicative of carotid artery atherosclerosis. In one embodiment the snoring is indicative of a turbulence in carotid artery blood flow. In one embodiment the snoring is indicative of obstructive sleep apnea (OSA).

**[0380]** The foregoing description of various embodiments of the claimed person matter has been provided for the purposes of illustration and description. It is not intended to be exhaustive or to limit the claimed person matter to the precise forms disclosed. Many modifications and variations will be apparent to the practitioner skilled in the art. Particularly, while the concept "component" is used in the embodiments of the systems and methods described above, it will be evident that such concept can be interchangeably used with equivalent concepts such as, class, method, type, interface, module, object model, and other suitable concepts. Embodiments were chosen and described in order to best describe the principles of the invention and its practical application, thereby enabling others skilled in the relevant art to understand the claimed person matter, the various embodiments and with various modifications that are suited to the particular use contemplated.

What is claimed is:

1. A system for monitoring a person's snoring in a dwelling, comprising:
  - a detection device in communication with a user monitoring device, the detection device including at least one motion/movement gesture sensing device configured to detect at least one of a person's motion, movement and gesture; and
  - a user monitoring device including at least one element selected from: a proximity sensor; a temperature sensor; a humidity sensor; a particulate sensor; a light sensor; a microphone; one or more RF transmitters (BLE/ANT+WIFI); a memory; and one or more LED's, wherein the detection device and user monitoring device detect a person's level of snoring.
2. The system of claim 1, wherein the detection device detects a vibration of respiratory structures.
3. The system of claim 2, wherein the vibration results in snoring sounds.
4. The system of claim 3, wherein the vibration results in sound due to obstructed air movement during breathing while sleeping.
5. The system of claim 4, wherein the sound is soft.
6. The system of claim 4, wherein the sound is loud.

7. The system of claim 3, wherein the snoring sounds is a factor of sleep deprivation.

8. The system of claim 3, wherein the snoring causes sleep deprivation.

9. The system of claim 3, wherein the snoring is indicative of sleep deprivation.

10. The system of claim 3, wherein the snoring is indication of heart disease.

11. The system of claim 3, wherein the snoring is indicative of carotid artery atherosclerosis.

12. The system of claim 3, wherein the snoring is indicative of a turbulence in carotid artery blood flow.

13. The system of claim 3, wherein the snoring is indicative of obstructive sleep apnea (OSA).

14. A method for monitoring a person's snoring in a dwelling, comprising:

providing a detection device in communication with a user monitoring device, the detection device including at least one motion/movement gesture sensing device configured to detect at least one of a person's motion, movement and gesture;

providing a user monitoring device including at least one element selected from: a proximity sensor; a temperature sensor; a humidity sensor; a particulate sensor; a light sensor; a microphone; one or more RF transmitters (BLE/ANT+WIFI); a memory; and one or more LED's; and

using the detection device and the user monitoring device to detect a person's level of snoring.

15. The method of claim 1, wherein the detection device detects a vibration of respiratory structures.

16. The method of claim 15, wherein the vibration results in snoring sounds.

17. The method of claim 16, wherein the vibration results in sound due to obstructed air movement during breathing while sleeping.

18. The method of claim 17, wherein the sound is soft.

19. The method of claim 17, wherein the sound is loud.

20. The method of claim 16, wherein the snoring sounds is a factor of sleep deprivation.

21. The method of claim 16, wherein the snoring causes sleep deprivation.

22. The method of claim 16, wherein the snoring is indicative of sleep deprivation.

23. The method of claim 16, wherein the snoring is indication of heart disease.

24. The method of claim 16, wherein the snoring is indicative of carotid artery atherosclerosis.

25. The method of claim 16, wherein the snoring is indicative of a turbulence in carotid artery blood flow.

26. The system of claim 16, wherein the snoring is indicative of obstructive sleep apnea (OSA).

\* \* \* \* \*

专利名称(译)	用于打鼾的监控设备		
公开(公告)号	<a href="#">US20160174894A1</a>	公开(公告)日	2016-06-23
申请号	US15/058809	申请日	2016-03-02
[标]申请(专利权)人(译)	你好		
申请(专利权)人(译)	HELLO INC.		
当前申请(专利权)人(译)	FITBIT INC.		
[标]发明人	PROUD JAMES		
发明人	PROUD, JAMES		
IPC分类号	A61B5/00 A61B7/00 A61B7/04 A61B5/113 A61B5/01		
CPC分类号	A61B5/4818 A61B5/113 A61B5/01 A61B5/0059 A61B7/04 A61B2560/0242 A61B7/003 A61B5/6889 A61B2505/07 A61B2562/029 A61B5/0024		
优先权	62/027885 2014-07-23 US 62/118384 2015-02-19 US		
外部链接	<a href="#">Espacenet</a> <a href="#">USPTO</a>		

摘要(译)

提供了用于监视人在住所中打鼾的系统和方法。检测设备与用户监控设备通信。检测装置包括至少一个运动/运动手势感测装置，其被配置为检测人的运动，运动和手势中的至少一个。用户监视设备包括选自以下的至少一个元件：接近传感器；温度传感器；湿度传感器；颗粒传感器；光传感器；麦克风；一个或多个射频发射器（BLE / ANT + WIFI）；记忆；和一个或多个LED。检测设备和用户监控设备检测人的打鼾水平。

