



US009586050B2

(12) **United States Patent**
Ghosh et al.

(10) **Patent No.:** **US 9,586,050 B2**
(45) **Date of Patent:** ***Mar. 7, 2017**

(54) **SYSTEMS AND METHODS FOR CONFIGURATION OF ATRIOVENTRICULAR INTERVAL**

A61N 1/36514 (2013.01); *A61N 1/37247* (2013.01); *A61N 1/37264* (2013.01)

(71) Applicant: **Medtronic, Inc.**, Minneapolis, MN (US)

(58) **Field of Classification Search**
CPC .. *A61N 1/3625*; *A61N 1/3706*; *A61N 1/3684*; *A61B 5/04085*; *A61B 5/6823*
See application file for complete search history.

(72) Inventors: **Subham Ghosh**, Blaine, MN (US);
Jeffrey Gillberg, Coon Rapids, MN (US)

(56) **References Cited**

U.S. PATENT DOCUMENTS

(73) Assignee: **Medtronic, Inc.**, Minneapolis, MN (US)

4,233,987 A 11/1980 Feingold
4,402,323 A 9/1983 White
4,428,378 A 1/1984 Anderson et al.
(Continued)

(*) Notice: Subject to any disclaimer, the term of this patent is extended or adjusted under 35 U.S.C. 154(b) by 0 days.

This patent is subject to a terminal disclaimer.

FOREIGN PATENT DOCUMENTS

CN 1043621 A 7/1990
CN 1253761 A 5/2000
(Continued)

(21) Appl. No.: **14/703,365**

(22) Filed: **May 4, 2015**

OTHER PUBLICATIONS

(65) **Prior Publication Data**

US 2016/0045738 A1 Feb. 18, 2016

U.S. Appl. No. 14/173,288, filed Feb. 5, 2014, Sambelashvili.
(Continued)

Related U.S. Application Data

(60) Provisional application No. 62/037,700, filed on Aug. 15, 2014.

Primary Examiner — Robert N Wieland
(74) *Attorney, Agent, or Firm* — Carol F. Barry

(51) **Int. Cl.**

A61N 1/00 (2006.01)
A61N 1/368 (2006.01)
A61N 1/365 (2006.01)
A61N 1/372 (2006.01)

(Continued)

(57) **ABSTRACT**

Systems and methods are described herein for assisting a user in identification and/or optimization of an atrioventricular (A-V) interval for use in cardiac therapy. The systems and methods may monitor electrical activity of a patient using external electrode apparatus to provide electrical heterogeneity information for a plurality of different A-V intervals and may identify an A-V interval based on the electrical heterogeneity information.

(52) **U.S. Cl.**

CPC *A61N 1/3684* (2013.01); *A61B 5/04085* (2013.01); *A61B 5/6823* (2013.01); *A61N 1/365* (2013.01); *A61N 1/3682* (2013.01);

28 Claims, 11 Drawing Sheets

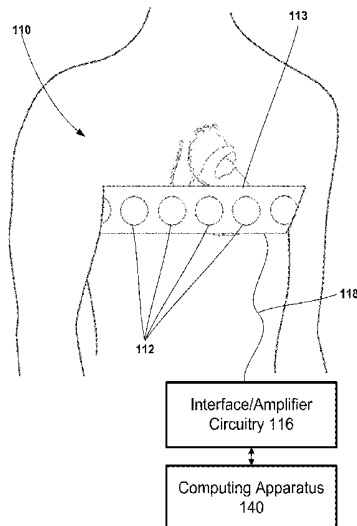

(51)	Int. Cl.							
	<i>A61B 5/0408</i>	(2006.01)		7,062,315 B2	6/2006	Koyrakh et al.		
	<i>A61B 5/00</i>	(2006.01)		7,092,759 B2	8/2006	Nehls et al.		
				7,142,922 B2	11/2006	Spinelli et al.		
				7,184,835 B2	2/2007	Kramer et al.		
				7,215,998 B2	5/2007	Wesselink et al.		
(56)	References Cited			7,286,866 B2	10/2007	Okerlund et al.		
	U.S. PATENT DOCUMENTS			7,308,297 B2	12/2007	Reddy et al.		
				7,308,299 B2	12/2007	Burrell et al.		
				7,313,444 B2	12/2007	Pianca et al.		
				7,321,677 B2	1/2008	Evron et al.		
	4,497,326 A	2/1985	Curry	7,346,381 B2	3/2008	Okerlund et al.		
	4,566,456 A	1/1986	Koning et al.	7,398,116 B2	7/2008	Edwards		
	4,593,702 A	6/1986	Kepski	7,426,412 B1	9/2008	Schecter		
	4,674,511 A	6/1987	Cartmell	7,454,248 B2	11/2008	Burrell et al.		
	4,763,660 A	8/1988	Kroll et al.	7,499,743 B2	3/2009	Vass et al.		
	4,777,955 A	10/1988	Brayton et al.	7,509,170 B2	3/2009	Zhang et al.		
	4,787,389 A	11/1988	Tarjan	7,565,190 B2	7/2009	Okerlund et al.		
	4,979,507 A	12/1990	Heinz et al.	7,587,074 B2	9/2009	Zarkh et al.		
	5,052,388 A	10/1991	Sivula et al.	7,599,730 B2	10/2009	Hunter et al.		
	5,054,496 A	10/1991	Wen et al.	7,610,088 B2	10/2009	Chinchoy		
	5,311,873 A	5/1994	Savard et al.	7,613,500 B2	11/2009	Vass et al.		
	5,331,960 A	7/1994	Levine	7,616,993 B2	11/2009	Müssig et al.		
	5,334,220 A	8/1994	Sholder	7,664,550 B2	2/2010	Eick et al.		
	5,443,492 A	8/1995	Stokes et al.	7,684,863 B2	3/2010	Parikh et al.		
	5,485,849 A	1/1996	Panescu et al.	7,742,629 B2	6/2010	Zarkh et al.		
	5,514,163 A	5/1996	Markowitz et al.	7,747,047 B2	6/2010	Okerlund et al.		
	5,552,645 A	9/1996	Weng	7,751,882 B1	7/2010	Helland		
	5,628,778 A	5/1997	Kruse et al.	7,769,451 B2	8/2010	Yang et al.		
	5,671,752 A	9/1997	Sinderby et al.	7,778,685 B2	8/2010	Evron et al.		
	5,683,429 A	11/1997	Mehra	7,778,686 B2	8/2010	Vass et al.		
	5,683,432 A	11/1997	Goedeke et al.	7,787,951 B1	8/2010	Min		
	5,687,737 A	11/1997	Branham et al.	7,813,785 B2	10/2010	Okerlund et al.		
	5,810,740 A	9/1998	Paisner	7,818,040 B2	10/2010	Spear et al.		
	5,876,336 A	3/1999	Swanson et al.	7,848,807 B2	12/2010	Wang		
	5,891,045 A	4/1999	Albrecht et al.	7,860,580 B2	12/2010	Falk et al.		
	5,922,014 A	7/1999	Warman et al.	7,894,889 B2	2/2011	Zhang		
	6,055,448 A	4/2000	Anderson et al.	7,912,544 B1	3/2011	Min et al.		
	6,128,535 A	10/2000	Maarse	7,917,214 B1	3/2011	Gill et al.		
	6,141,588 A	10/2000	Cox et al.	7,941,213 B2	5/2011	Markowitz et al.		
	6,187,032 B1	2/2001	Ohyu et al.	7,953,475 B2	5/2011	Harlev et al.		
	6,205,357 B1	3/2001	Ideker et al.	7,953,482 B2	5/2011	Hess		
	6,226,542 B1	5/2001	Reisfeld	7,983,743 B2	7/2011	Rudy et al.		
	6,236,883 B1	5/2001	Ciaccio et al.	7,996,063 B2	8/2011	Vass et al.		
	6,243,603 B1	6/2001	Ideker et al.	7,996,070 B2	8/2011	van Dam et al.		
	6,246,898 B1	6/2001	Vesely et al.	8,010,194 B2	8/2011	Muller		
	6,301,496 B1	10/2001	Reisfeld	8,019,402 B1	9/2011	Kryzpow et al.		
	6,311,089 B1	10/2001	Mann et al.	8,019,409 B2	9/2011	Rosenberg et al.		
	6,330,476 B1	12/2001	Ben-Haim et al.	8,032,229 B2	10/2011	Gerber et al.		
	6,358,214 B1	3/2002	Tereschouk	8,036,743 B2	10/2011	Savage et al.		
	6,377,856 B1	4/2002	Carson	8,060,185 B2	11/2011	Hunter et al.		
	6,381,493 B1	4/2002	Stadler et al.	8,150,513 B2	4/2012	Chinchoy		
	6,393,316 B1	5/2002	Gillberg et al.	8,160,700 B1	4/2012	Ryu et al.		
	6,418,346 B1	7/2002	Nelson et al.	8,175,703 B2	5/2012	Dong et al.		
	6,442,433 B1	8/2002	Linberg	8,180,428 B2	5/2012	Kaiser et al.		
	6,456,867 B2	9/2002	Reisfeld	8,195,292 B2	6/2012	Rosenberg et al.		
	6,473,638 B2	10/2002	Ferek-Petric	8,213,693 B1	7/2012	Li		
	6,480,745 B2	11/2002	Nelson et al.	8,214,041 B2	7/2012	Van Gelder et al.		
	6,484,118 B1	11/2002	Govari	8,265,738 B1	9/2012	Min et al.		
	6,507,756 B1	1/2003	Heynen et al.	8,285,377 B2	10/2012	Rosenberg et al.		
	6,532,379 B2	3/2003	Stratbucker	8,295,943 B2	10/2012	Eggen et al.		
	6,584,343 B1	6/2003	Ransbury et al.	8,326,419 B2	12/2012	Rosenberg et al.		
	6,599,250 B2	7/2003	Webb et al.	8,332,030 B2	12/2012	Hess et al.		
	6,625,482 B1	9/2003	Panescu et al.	8,380,308 B2	2/2013	Rosenberg et al.		
	6,640,136 B1	10/2003	Helland et al.	8,401,616 B2	3/2013	Verard et al.		
	6,650,927 B1	11/2003	Keidar	8,478,388 B2	7/2013	Nguyen et al.		
	6,766,189 B2	7/2004	Yu et al.	8,527,051 B1	9/2013	Hedberg et al.		
	6,772,004 B2	8/2004	Rudy	8,583,230 B2	11/2013	Ryu et al.		
	6,804,555 B2	10/2004	Warkentin	8,615,298 B2	12/2013	Ghosh et al.		
	6,847,836 B1	1/2005	Sujdak	8,617,082 B2	12/2013	Zhang et al.		
	6,856,830 B2	2/2005	He	8,620,433 B2	12/2013	Ghosh et al.		
	6,882,882 B2	4/2005	Struble et al.	8,639,333 B2	1/2014	Stadler et al.		
	6,885,889 B2	4/2005	Chinchoy	8,694,099 B2	4/2014	Ghosh et al.		
	6,915,149 B2	7/2005	Ben-Haim	8,738,132 B1	5/2014	Ghosh et al.		
	6,968,237 B2	11/2005	Doan et al.	8,744,576 B2	6/2014	Munsterman et al.		
	6,975,900 B2	12/2005	Rudy et al.	8,768,465 B2	7/2014	Ghosh et al.		
	6,978,184 B1	12/2005	Marcus et al.	8,805,504 B2	8/2014	Sweeney		
	6,980,675 B2	12/2005	Evron et al.	8,972,228 B2	3/2015	Ghosh et al.		
	7,016,719 B2	3/2006	Rudy et al.	9,037,238 B2	5/2015	Stadler et al.		
	7,031,777 B2	4/2006	Hine et al.	9,155,897 B2	10/2015	Ghosh et al.		
	7,058,443 B2	6/2006	Struble					

(56)

References Cited

U.S. PATENT DOCUMENTS

9,199,087	B2	12/2015	Stadler et al.	2009/0270729	A1	10/2009	Corbucci et al.
9,265,951	B2	2/2016	Sweeney	2009/0270937	A1	10/2009	Yonce et al.
9,265,954	B2	2/2016	Ghosh	2009/0299201	A1	12/2009	Gunderson
9,265,955	B2	2/2016	Ghosh	2009/0299423	A1	12/2009	Min
9,278,219	B2	3/2016	Ghosh	2009/0306732	A1	12/2009	Rosenberg et al.
9,278,220	B2	3/2016	Ghosh	2009/0318995	A1	12/2009	Keel et al.
9,282,907	B2	3/2016	Ghosh	2010/0022873	A1	1/2010	Hunter et al.
9,320,446	B2	4/2016	Gillberg et al.	2010/0049063	A1	2/2010	Dobak, III
2002/0087089	A1	7/2002	Ben-Haim	2010/0069987	A1	3/2010	Min et al.
2002/0143264	A1	10/2002	Ding et al.	2010/0087888	A1	4/2010	Maskara
2002/0161307	A1	10/2002	Yu et al.	2010/0094149	A1	4/2010	Kohut et al.
2002/0169484	A1	11/2002	Mathis et al.	2010/0113954	A1	5/2010	Zhou
2003/0018277	A1	1/2003	He	2010/0114229	A1	5/2010	Chinchoy
2003/0050670	A1	3/2003	Spinelli et al.	2010/0121403	A1	5/2010	Schecter et al.
2003/0105495	A1	6/2003	Yu et al.	2010/0145405	A1	6/2010	Min et al.
2003/0236466	A1	12/2003	Tarjan et al.	2010/0174137	A1	7/2010	Shim
2004/0015081	A1	1/2004	Kramer et al.	2010/0198292	A1	8/2010	Honeck et al.
2004/0059237	A1	3/2004	Narayan et al.	2010/0228138	A1	9/2010	Chen
2004/0097806	A1	5/2004	Hunter et al.	2010/0234916	A1	9/2010	Turcott et al.
2004/0102812	A1	5/2004	Yonce et al.	2010/0254583	A1	10/2010	Chan et al.
2004/0122479	A1	6/2004	Spinelli et al.	2010/0268059	A1	10/2010	Ryu et al.
2004/0162496	A1	8/2004	Yu et al.	2011/0004111	A1	1/2011	Gill et al.
2004/0172078	A1	9/2004	Chinchoy	2011/0004264	A1	1/2011	Siejko et al.
2004/0172079	A1	9/2004	Chinchoy	2011/0022112	A1	1/2011	Min
2004/0193223	A1	9/2004	Kramer et al.	2011/0054286	A1	3/2011	Crosby
2004/0215245	A1	10/2004	Stahmann et al.	2011/0054559	A1	3/2011	Rosenberg et al.
2004/0215252	A1	10/2004	Verbeek et al.	2011/0054560	A1	3/2011	Rosenberg et al.
2004/0220635	A1	11/2004	Burnes	2011/0075896	A1	3/2011	Matsumoto
2004/0267321	A1	12/2004	Boileau et al.	2011/0092809	A1	4/2011	Nguyen et al.
2005/0008210	A1	1/2005	Evron et al.	2011/0112398	A1	5/2011	Zarkh et al.
2005/0027320	A1	2/2005	Nehls et al.	2011/0118803	A1	5/2011	Hou et al.
2005/0090870	A1	4/2005	Hine et al.	2011/0137369	A1	6/2011	Ryu et al.
2005/0096522	A1	5/2005	Reddy et al.	2011/0144510	A1	6/2011	Ryu et al.
2005/0149138	A1	7/2005	Min et al.	2011/0172728	A1	7/2011	Wang
2006/0074285	A1	4/2006	Zarkh et al.	2011/0190615	A1	8/2011	Phillips et al.
2006/0224198	A1*	10/2006	Dong A61N 1/368 607/9	2011/0201915	A1	8/2011	Gogin et al.
2006/0235478	A1	10/2006	Van Gelder et al.	2011/0213260	A1	9/2011	Keel et al.
2006/0253162	A1	11/2006	Zhang et al.	2011/0319954	A1	12/2011	Niazi et al.
2007/0142871	A1	6/2007	Libbus et al.	2012/0004567	A1	1/2012	Eberle et al.
2007/0232943	A1	10/2007	Harel et al.	2012/0101543	A1	4/2012	Demmer et al.
2007/0250129	A1	10/2007	Van Oort	2012/0101546	A1	4/2012	Stadler et al.
2007/0265508	A1	11/2007	Sheikhzadeh-Nadjar et al.	2012/0203090	A1	8/2012	Min
2008/0021336	A1	1/2008	Dobak et al.	2012/0253419	A1	10/2012	Rosenberg et al.
2008/0058656	A1	3/2008	Costello et al.	2012/0283587	A1	11/2012	Gosh et al.
2008/0119903	A1	5/2008	Arcot-Krishnamurthy et al.	2012/0284003	A1	11/2012	Gosh et al.
2008/0140143	A1	6/2008	Ettori et al.	2012/0296387	A1	11/2012	Zhang et al.
2008/0146954	A1	6/2008	Bojovic et al.	2012/0296388	A1	11/2012	Zhang et al.
2008/0242976	A1	10/2008	Robertson et al.	2012/0302904	A1	11/2012	Lian et al.
2008/0269818	A1	10/2008	Sullivan et al.	2012/0303084	A1	11/2012	Kleckner et al.
2008/0269823	A1	10/2008	Burnes et al.	2012/0310297	A1	12/2012	Sweeney
2008/0281195	A1	11/2008	Heimdal	2012/0330179	A1	12/2012	Yuk et al.
2008/0306567	A1	12/2008	Park et al.	2013/0006332	A1	1/2013	Sommer et al.
2008/0306568	A1	12/2008	Ding et al.	2013/0018250	A1	1/2013	Caprio et al.
2009/0005832	A1	1/2009	Zhu et al.	2013/0018251	A1	1/2013	Caprio et al.
2009/0036947	A1	2/2009	Westlund et al.	2013/0030491	A1	1/2013	Stadler et al.
2009/0043352	A1	2/2009	Brooke et al.	2013/0060298	A1	3/2013	Splett et al.
2009/0048528	A1	2/2009	Hopenfeld et al.	2013/0072790	A1	3/2013	Ludwig et al.
2009/0053102	A2	2/2009	Rudy et al.	2013/0096446	A1	4/2013	Michael et al.
2009/0054941	A1	2/2009	Eggen et al.	2013/0116739	A1	5/2013	Brada et al.
2009/0054946	A1	2/2009	Sommer et al.	2013/0131529	A1	5/2013	Jia et al.
2009/0084382	A1	4/2009	Jalde et al.	2013/0131749	A1	5/2013	Sheldon et al.
2009/0093857	A1	4/2009	Markowitz et al.	2013/0131751	A1	5/2013	Stadler et al.
2009/0099468	A1	4/2009	Thiagalingam et al.	2013/0136035	A1	5/2013	Bange et al.
2009/0099469	A1	4/2009	Flores	2013/0150913	A1	6/2013	Bornzin et al.
2009/0099619	A1	4/2009	Lessmeier et al.	2013/0165983	A1	6/2013	Ghosh et al.
2009/0112109	A1	4/2009	Kuklik et al.	2013/0165988	A1	6/2013	Ghosh
2009/0143838	A1	6/2009	Libbus et al.	2013/0261471	A1	10/2013	Saha et al.
2009/0157134	A1	6/2009	Ziglio et al.	2013/0261688	A1	10/2013	Dong et al.
2009/0157136	A1	6/2009	Yang et al.	2013/0289640	A1	10/2013	Zhang et al.
2009/0198298	A1	8/2009	Kaiser et al.	2013/0296726	A1	11/2013	Niebauer et al.
2009/0216112	A1	8/2009	Assis et al.	2013/0304407	A1	11/2013	George et al.
2009/0232448	A1	9/2009	Barmash et al.	2013/0324828	A1	12/2013	Nishiwaki et al.
2009/0234414	A1	9/2009	Sambelashvili et al.	2014/0005563	A1	1/2014	Ramanathan et al.
2009/0254140	A1	10/2009	Rosenberg et al.	2014/0018872	A1	1/2014	Siejko et al.
				2014/0135866	A1	5/2014	Ramanathan et al.
				2014/0135867	A1	5/2014	Demmer et al.
				2014/0163633	A1	6/2014	Ghosh et al.
				2014/0222099	A1	8/2014	Sweeney
				2014/0236252	A1	8/2014	Ghosh et al.

(56) References Cited

U.S. PATENT DOCUMENTS

2014/0276125 A1 9/2014 Hou et al.
 2014/0277233 A1 9/2014 Ghosh
 2014/0323882 A1 10/2014 Ghosh et al.
 2014/0323892 A1 10/2014 Ghosh et al.
 2014/0323893 A1 10/2014 Ghosh et al.
 2014/0371807 A1 12/2014 Ghosh et al.
 2014/0371808 A1 12/2014 Ghosh et al.
 2014/0371832 A1 12/2014 Ghosh
 2014/0371833 A1 12/2014 Ghosh et al.
 2015/0032016 A1 1/2015 Ghosh
 2015/0032171 A1 1/2015 Ghosh
 2015/0032172 A1 1/2015 Ghosh
 2015/0032173 A1 1/2015 Ghosh
 2015/0045849 A1 2/2015 Ghosh et al.
 2015/0142069 A1 5/2015 Sambelashvili
 2015/0157225 A1 6/2015 Gillberg et al.
 2015/0157231 A1 6/2015 Gillberg et al.
 2015/0157232 A1 6/2015 Gillberg et al.
 2015/0157865 A1 6/2015 Gillberg et al.
 2015/0216434 A1 8/2015 Ghosh et al.
 2015/0265840 A1 9/2015 Ghosh et al.
 2016/0030747 A1 2/2016 Thakur et al.
 2016/0030751 A1 2/2016 Ghosh et al.
 2016/0045737 A1 2/2016 Ghosh et al.
 2016/0045744 A1 2/2016 Ghosh et al.
 2016/0184590 A1 6/2016 Ghosh

FOREIGN PATENT DOCUMENTS

CN 1878595 A 12/2006
 CN 101073502 A 11/2007
 EP 1 072 284 A2 1/2001
 EP 1 504 713 A1 2/2005
 EP 2016976 A1 1/2009
 EP 2391270 A1 7/2011
 EP 1 925 337 B1 3/2012
 EP 2436309 A2 4/2012
 EP 2 435 132 B1 8/2013
 WO WO 98/26712 A1 6/1998
 WO WO 99/06112 A1 2/1999
 WO WO 00/45700 A1 8/2000
 WO WO 01/67950 A1 9/2001
 WO WO 03/070323 A1 8/2003
 WO WO 2005/056108 A2 6/2005
 WO WO 2006/069215 A2 6/2006
 WO WO 2006/105474 A2 10/2006
 WO WO 2006/115777 A1 11/2006
 WO WO 2006/117773 A1 11/2006
 WO WO 2007/013994 A2 2/2007
 WO WO 2007/027940 A2 3/2007
 WO WO 2007/013994 A3 4/2007
 WO WO 2007/027940 A3 6/2007
 WO WO 2007/139456 A1 12/2007
 WO WO 2008/151077 A2 12/2008
 WO WO 2006/069215 A3 6/2009
 WO WO 2009/079344 A1 6/2009
 WO WO 2009/139911 A2 11/2009
 WO WO 2009/148429 A1 12/2009
 WO WO 2010/019494 A1 2/2010
 WO WO 2010/071520 A1 6/2010
 WO WO 2010/088040 A1 8/2010
 WO WO 2010/088485 A1 8/2010
 WO WO 2011/070166 A1 6/2011
 WO WO 2011/090622 A1 7/2011
 WO WO 2011/099992 A1 8/2011
 WO WO 2012/037471 A2 3/2012
 WO WO 2012/037471 A3 6/2012
 WO WO 2012/106297 A2 8/2012
 WO WO 2012/106297 A3 8/2012
 WO WO 2012/109618 A2 8/2012
 WO WO 2012/110940 A1 8/2012
 WO WO 2012/109618 A3 11/2012
 WO WO 2012/151364 A1 11/2012
 WO WO 2012/151389 A1 11/2012
 WO WO 2013/006724 A2 1/2013

WO WO 2013/010165 A1 1/2013
 WO WO 2013/010184 A1 1/2013
 WO WO 2013/006724 A3 4/2013
 WO WO 2014/179454 A1 11/2014
 WO WO 2014/179459 A2 11/2014
 WO WO 2015/013271 A1 1/2015
 WO WO 2015/013493 A1 1/2015
 WO WO 2015/013574 A1 1/2015

OTHER PUBLICATIONS

U.S. Appl. No. 14/220,733, filed Mar. 20, 2014, Ghosh et al.
 U.S. Appl. No. 14/227,719, filed Mar. 27, 2014, Gillberg et al.
 U.S. Appl. No. 14/228,009, filed Mar. 27, 2014, Gillberg et al.
 U.S. Appl. No. 14/228,024, filed Mar. 27, 2014, Ghosh et al.
 U.S. Appl. No. 14/228,038, filed Mar. 27, 2014, Ghosh et al.
 International Search Report and Written Opinion issued May 3, 2012 for International Application No. PCT/US2014/036262; 9 pages.
 International Search Report and Written Opinion issued May 3, 2012 for International Application No. PCT/US2014/036302; 9 pages.
 International Search Report and Written Opinion issued Aug. 6, 2014 for International Application No. PCT/US2014/036153; 14 pages.
 International Search Report and Written Opinion issued Nov. 7, 2014 for International Application No. PCT/US2014/036163; 12 pages.
 International Search Report and Written Opinion issued Oct. 28, 2014 for International Application No. PCT/US2014/041928; 15 pages.
 International Search Report and Written Opinion issued Oct. 24, 2014 for International Application No. PCT/US2014/041929; 14 pages.
 International Search Report and Written Opinion issued on Mar. 9, 2015 for International Application No. PCT/US2014/069214; 11 pages.
 International Search Report and Written Opinion issued on Mar. 17, 2015, for International Application No. PCT/US2014/069192; 11 pages.
 International Search Report and Written Opinion issued on Mar. 16, 2015 for International Application No. PCT/US2014/069182; 11 pages.
 International Search Report and Written Opinion issued on Apr. 8, 2015 for International Application No. PCT/US2014/069070; 11 pages.
 Biffi et al., "Occurrence of Phrenic Nerve Stimulation in Cardiac Resynchronization Therapy Patients: the Role of Left Ventricular Lead Type and Placement Site," *Europace*, 2013; 15:77-82.
 "CardioGuide System Enables Real-Time Navigation of Left Ventricular Leads During Medtronic CRT Implants," Press Release, Apr. 9, 2013, Medtronic, Inc., 2 pgs.
 Czerwinska et al., "Method of Segmentation of Thorax Organs Images Applied to Modeling the Cardiac Electrical Field," *Engineering in Medicine and Biology Society*, Proceedings of the 22nd Annual International Conference of the IEEE, vol. 1, 23, Jul. 23, 2000; pp. 402-405.
 Freund et al., "A Decision-Theoretic Generalization of Online Learning and an Application to Boosting," *Journal of Computer and System Sciences*, 1997; 55(1):119-139.
 Friedman, "Greedy Function Approximation: A Gradient Boosting Machine," *Annals of Statistics*, 2001; 29(5):1189-1232.
 Friedman, "Stochastic Gradient Boosting," *Computational Statistics and Data Analysis*, 2002; 38(4):367-378.
 Friedman et al., "Additive Logistic Regression: a Statistical View of Boosting," *Annals of Statistics*, 2000; 28(2):337-374.
 Ghosh et al. "Accuracy of Quadratic Versus Linear Interpolation in Noninvasive Electrocardiographic Imaging (ECGI)," *Annals of Biomedical Engineering*, vol. 33, No. 9, Sep. 2005; pp. 1187-1201.
 Ghosh et al., "Cardiac Memory in Patients with Wolff-Parkinson-White Syndrome: Noninvasive Imaging of Activation and Repolarization Before and After Catheter Ablation" *Circulation*, 2008; 118:907-915. Published online Aug. 12, 2008.

(56)

References Cited

OTHER PUBLICATIONS

- Ghosh et al. "Application of L1-Norm Regularization to Epicardial Potential Solution of the Inverse Electrocardiography Problem," *Annals of Biomedical Engineering*, vol. 37, No. 5, May 2009; pp. 902-912.
- Gold et al., "Comparison of Stimulation Sites within Left Ventricular Veins on the Acute Hemodynamic Effects of Cardiac Resynchronization Therapy" *Heart Rhythm*, Apr. 2005; 2(4):376-381.
- Gulrajani, "The Forward and Inverse Problems of Electrocardiography," *IEEE Engineering in Medicine and Biology*, IEEE Service Center, vol. 17, No. 5, Sep. 1, 1988; pp. 84-101, 122.
- Hansen, "Regularization Tools: A Matlab Package for Analysis and Solution of Discrete Ill-Posed Problems," Version 4.1 for Matlab 7.3; Mar. 2008; 128 pages. Retrieved from the Internet: Jun. 19, 2014 <http://www.mathworks.com/matlabcentral/fileexchange/52-regtools>.
- Hayes et al., "Cardiac Resynchronization Therapy and the Relationship of Percent Biventricular Pacing to Symptoms and Survival," *Heart Rhythm*, Sep. 2011; 8(9):1469-1475.
- "Heart Failure Management" datasheet [online]. Medtronic, Minneapolis, Minnesota, [Last updated on Jun. 3, 2013]. Retrieved from the Internet: www.medtronic.com; 9 pages.
- Jia et al., "Electrocardiographic Imaging of Cardiac Resynchronization Therapy in Heart Failure: Observation of Variable Electrophysiologic Responses," *Heart Rhythm*, vol. 3, No. 3; Mar. 1, 2006, pp. 296-310.
- Kornreich, "Body Surface Potential Mapping of ST Segment Changes in Acute Myocardial Infarction," *Circulation*, 1993; 87: 773-782.
- Modre et al., "Noninvasive Myocardial Activation Time Imaging: a Novel Inverse Algorithm Applied to Clinical ECG Mapping Data" *IEEE Transactions on Biomedical Engineering*, vol. 49; No. 10, Oct. 2002; pp. 1153-1161.
- Ridgeway, "The State of Boosting," *Computing Science and Statistics*, 1999; 31:172-181.
- Ryu et al., "Simultaneous Electrical and Mechanical Mapping Using 3D Cardiac Mapping System: Novel Approach for Optimal Cardiac Resynchronization Therapy," *Journal of Cardiovascular Electrophysiology*, Feb. 2010; 21(2):219-222.
- Silva et al., "Cardiac Resynchronization Therapy in Pediatric Congenital Heart Disease: Insights from Noninvasive Electrocardiographic Imaging" *Heart Rhythm*, vol. 6, No. 8. Aug. 1, 2009; pp. 1178-1185.
- Singh et al., "Left Ventricular Lead Position and Clinical Outcome in the Multicenter Automatic Defibrillator Implantation Trial-Cardiac Resynchronization Therapy (MADIT-CRT) Trial," *Circulation*, 2011; 123:1159-1166.
- Sperzel et al., "Intraoperative Characterization of Interventricular Mechanical Dyssynchrony Using Electroanatomic Mapping System—A feasibility Study," *Journal of Interventional Cardiac Electrophysiology*, Nov. 2012; 35(2):189-96.
- Steinhaus BM., "Estimating cardiac transmembrane activation and recovery times from unipolar and bipolar extracellular electrograms: a simulation study," *Circulation Research*, 1989, 64:449-462.
- Sweeney et al., "Analysis of Ventricular Activation Using Surface Electrocardiography to Predict Left Ventricular Reverse Volumetric Remodeling During Cardiac Resynchronization Therapy," *Circulation*, Feb. 9, 2010; 121(5):626-634.
- Turner et al., "Electrical and Mechanical Components of Dyssynchrony in Heart Failure Patients with Normal QRS Duration and Left Bundle-Branch Block," *Circulation* 2004; 109: 2544-2549.
- van Deursen et al., "Vectorcardiography as a Tool for Easy Optimization of Cardiac Resynchronization Therapy in Canine Left Bundle Branch Block Hearts," *Circulation Arrhythmia and Electrophysiology*, Jun. 1, 2012; 5(3):544-552.
- Vardas et al., The Task Force for Cardiac Pacing and Cardiac Resynchronization Therapy of the European Society of Cardiology. Developed in Collaboration with the European Heart Rhythm Association, *European Heart Journal*, 2007; 28:2256-2295.
- Varma et al., "Placebo CRT," *Journal of Cardiovascular Electrophysiology*, vol. 19, Aug. 2008; p. 878.
- Williams et al., "Short-Term Hemodynamic Effects of Cardiac Resynchronization Therapy in Patients With Heart Failure, a Narrow QRS Duration, and No Dyssynchrony," *Circulation*, Oct. 27, 2009; 120: 1687-1694.
- Botker MD, PhD., et al., "Electromechanical Mapping for Detection of Myocardial Viability in Patients with ischemia Cardiomyopathy," *Circulation*, Mar. 2001; vol. 103, No. 12, pp. 1631-1637.
- Cuculich, P.S., et al., "The Electrophysiological Cardiac Ventricular Substrate in Patients After Myocardial Infarction" *J. Am. Coll. Cardiol.* 2011; 58:1893-1902.
- Dawoud, F. et al., "Inverse Electrocardiographic Imaging to Assess Electrical Dyssynchrony in Cardiac Resynchronization Therapy Patients," *Computing in Cardiology*, 2012; 39:993-996.
- Fung et al., Chapter 20, Optimization of Cardiac Resynchronization Therapy, Cardiac Resynchronization Therapy, Second Edition, Copyright 2008, Blackwell Publishing Ltd., pp. 356-373.
- Ghosh et al., "Electrophysiological Substrate and Intraventricular LV Dyssynchrony in Non-ischemic Heart Failure Patients Undergoing Cardiac Resynchronization Therapy," *Heart rhythm : the official journal of the Heart Rhythm Society*, 2011; 8(5):692-699.
- Hopenfeld et al., "The Effect of Conductivity on ST—Segment Epicardial Potentials Arising from Subendocardial Ischemia," *Annals of Biomedical Eng.*, Jun. 2005; vol. 33, No. 6, pp. 751-763.
- Medtronic Vitatron Carelink Encore® Programmer Model 29901 Reference Manual, 2013, Medtronic, Inc., Minneapolis, MN.
- Miri et al., "Applicability of body surface potential map in computerized optimization of biventricular pacing," *Annals of Biomedical Engineering*, vol. 38, No. 3, Mar. 2010, pp. 865-875.
- Miri et al., "Comparison of the electrophysiologically based optimization methods with different pacing parameters in patient undergoing resynchronization treatment," *30th Annual International IEEE EMS Conference*, Aug. 2008, pp. 1741-1744.
- Miri et al., "Computerized Optimization of Biventricular Pacing Using Body Surface Potential Map," *31st Annual International Conference of the IEEE EMS*, Sep. 2009, pp. 2815-2818.
- Miri et al., "Efficiency of Timing Delays and Electrode Positions in Optimization of Biventricular Pacing: A Simulation Study," *IEEE Transactions on Biomedical Engineering*, Nov. 2009, pp. 2573-2582.
- Nash et al., "An Experimental-Computational Framework for Validating in-vivo ECG Inverse Algorithms," *International Journal of Bioelectromagnetism*, vol. 2, No. 2, Dec. 31, 2000, 9 pages.
- Potse et al., "Mathematical Modeling and Simulation of Ventricular Activation Sequences: Implications for Cardiac Resynchronization Therapy," *J. of Cardiovasc. Trans. Res.*, 2012; 5:146-158.
- Prinzen et al., "Cardiac Resynchronization Therapy State-of-the-Art of Current Applications, Guidelines, Ongoing Trials, and Areas of Controversy" *Circulation*, 2013; 128: 2407-2418.
- Strik et al., "Electrical and Mechanical Ventricular Activation During Left Bundle Branch Block and Resynchronization," *J. of Cardiovasc. Trans. Res.*, 2012; 5:117-126.
- Svendsen et al., "Computational Models of Cardiac Electrical Activation," Chapter 5, Computational Nov. 2010, pp. 73-88.
- Sweeney et al., QRS Fusion Complex Analysis Using Wave Interference to Predict Reverse Remodeling During Cardiac Resynchronization Therapy, *Heart Rhythm*, 2014, 11:806-813.
- Wang et al., "Application of the Method of Fundamental Solutions to Potential-based Inverse Electrocardiography," *Annals of Biomedical Engineering*, Aug. 2006, pp. 1272-1288.
- Wellens, MD et al., "The Electrocardiogram 102 Years After Einthoven," *Circulation*, Feb. 2004; vol. 109, No. 5, pp. 562-564.

* cited by examiner

FIG. 1

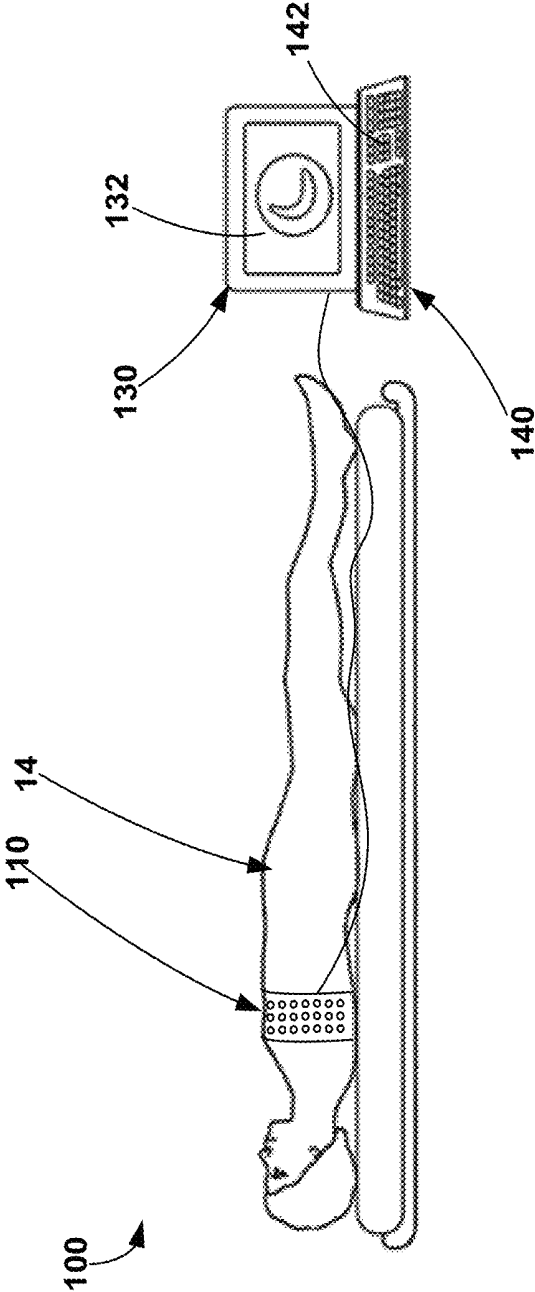

FIG. 2

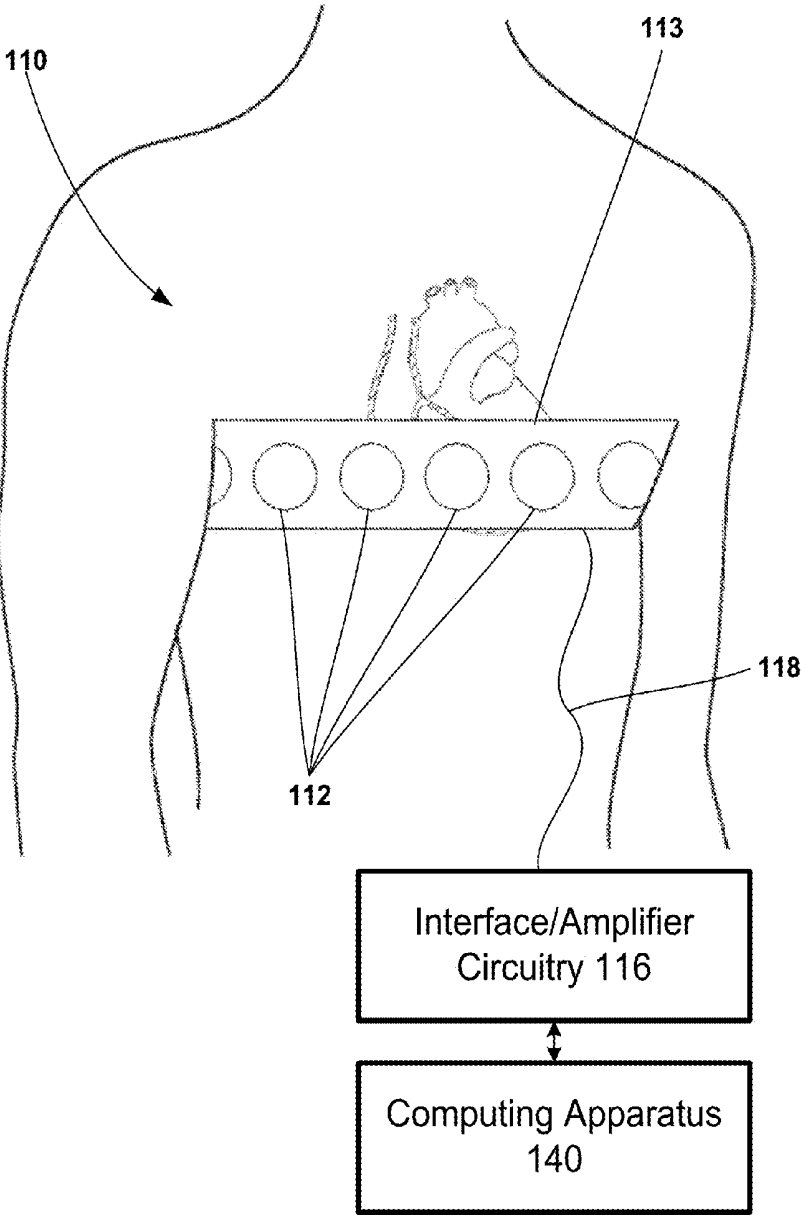

FIG. 3

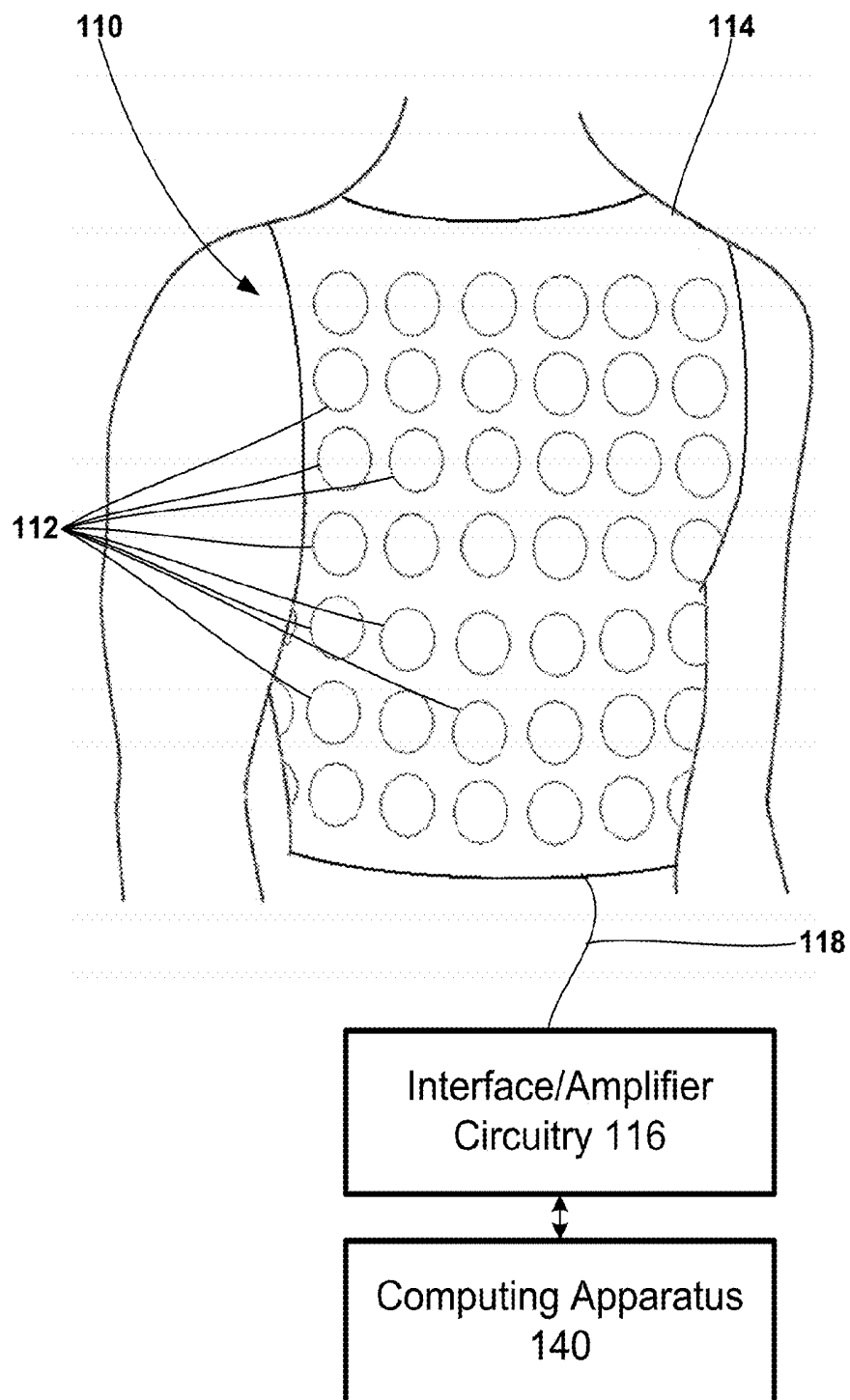

FIG. 4

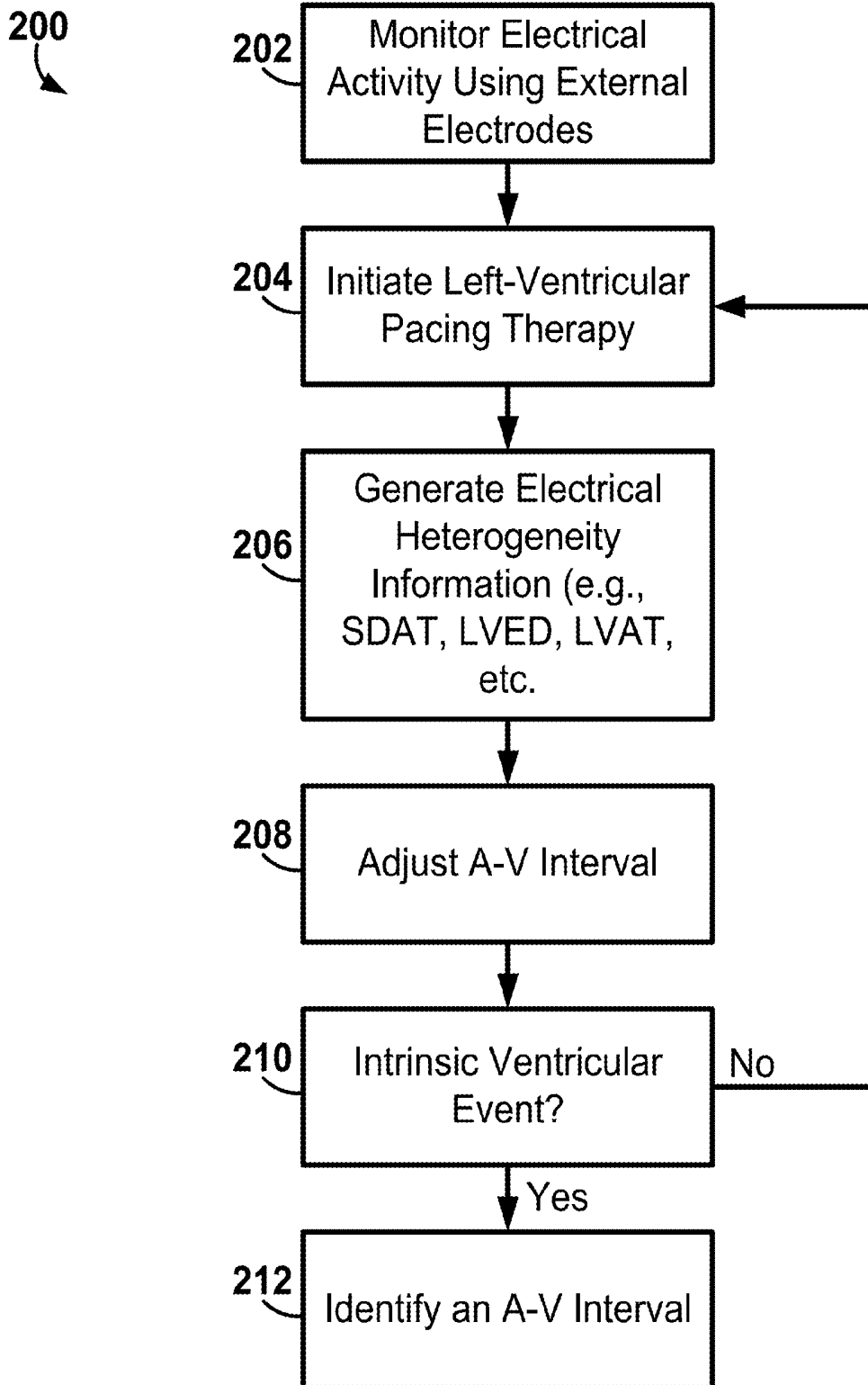

FIG. 5

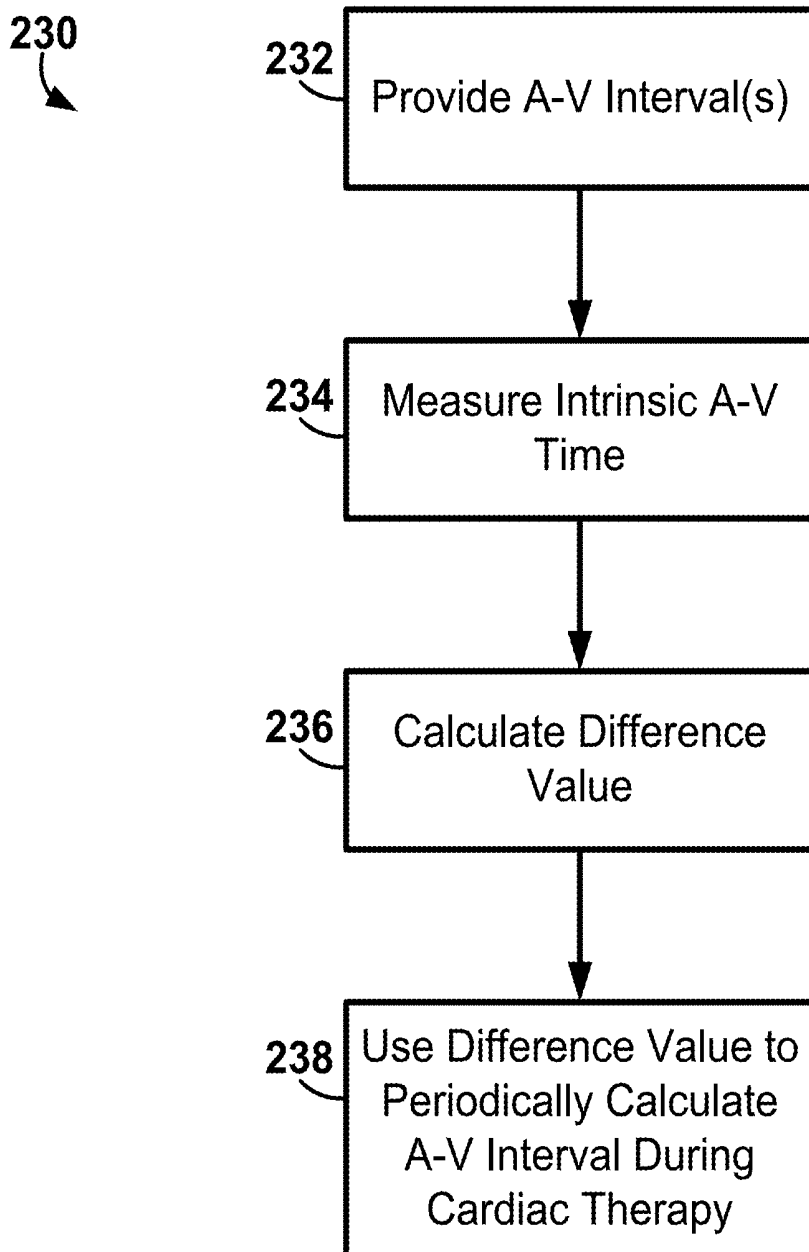

FIG. 6

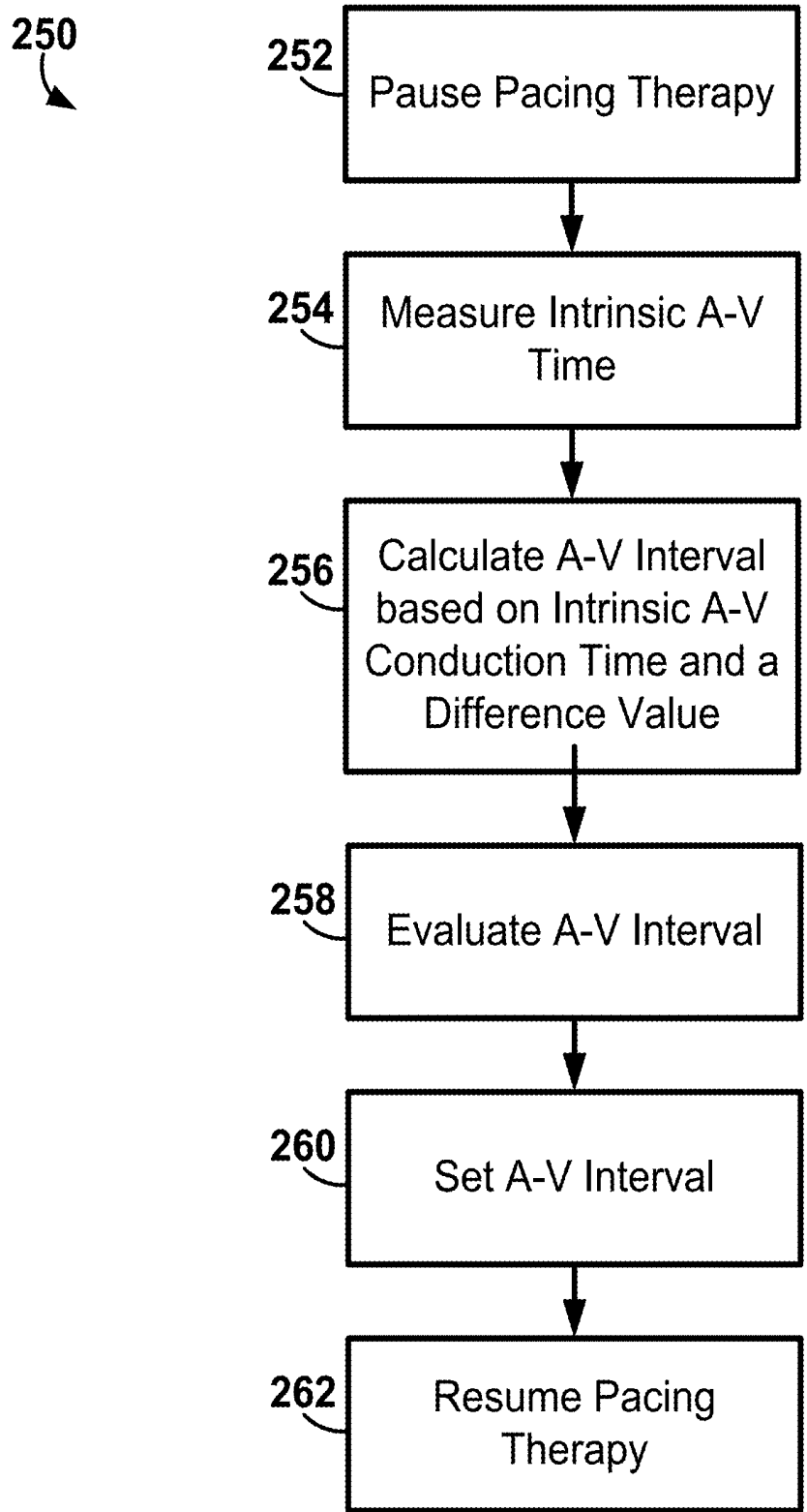

FIG. 7

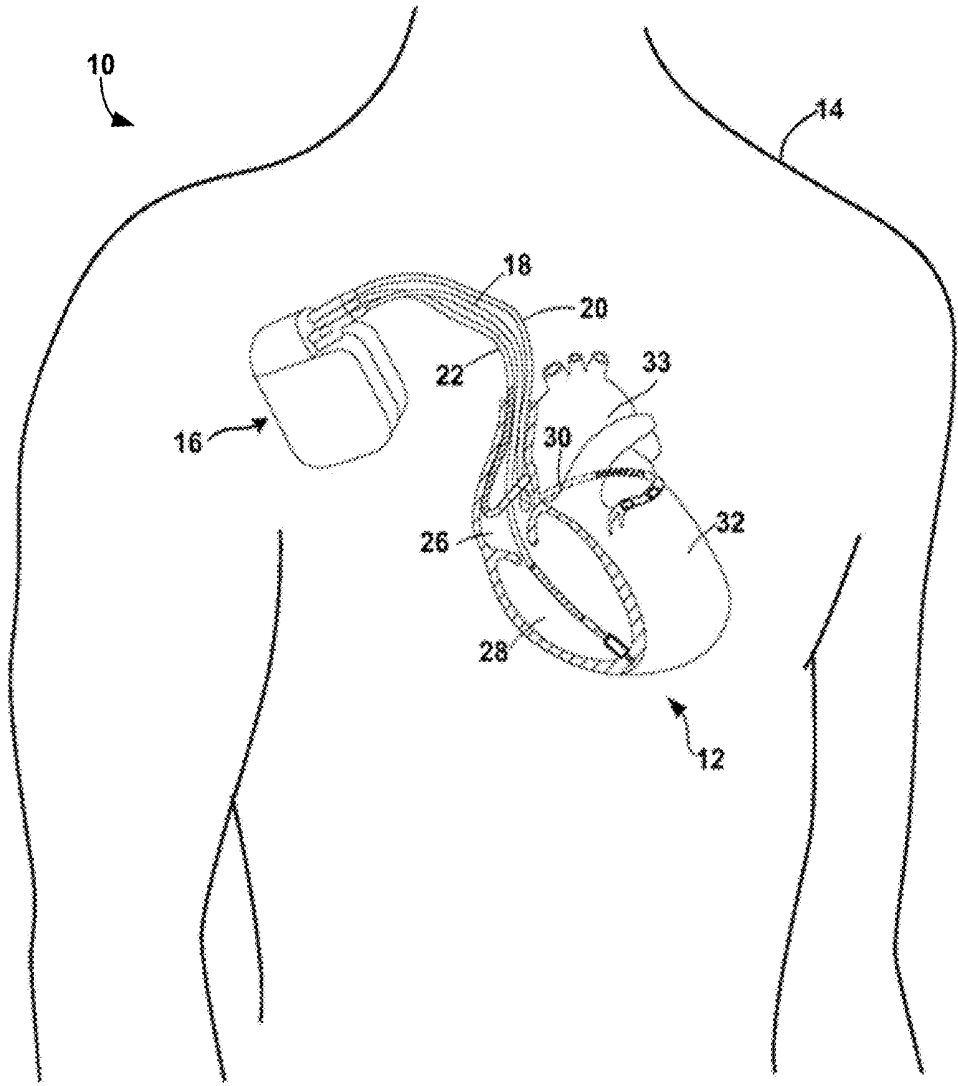

FIG. 8B

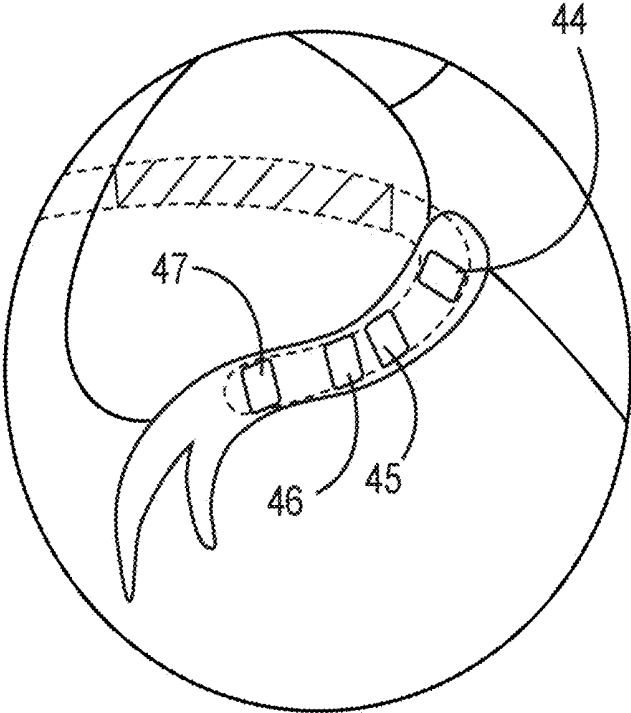

FIG. 9A

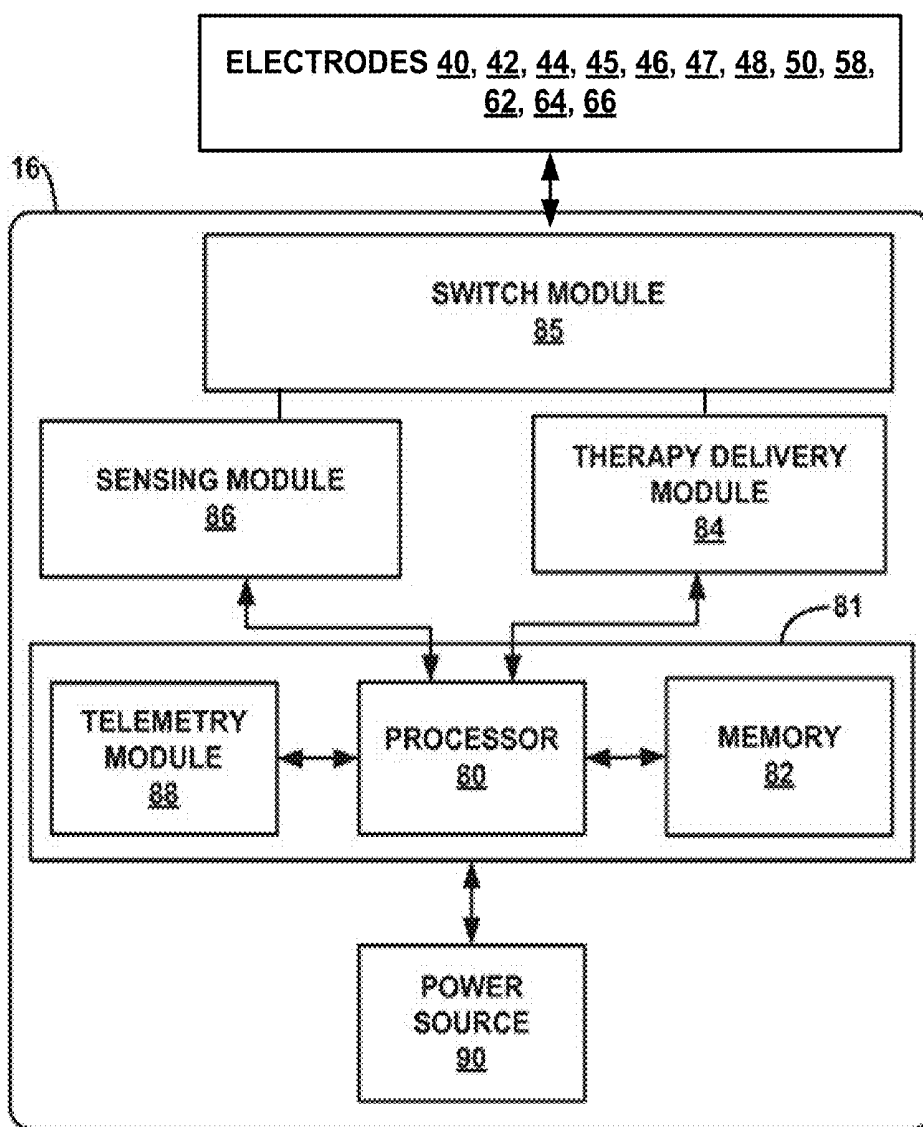
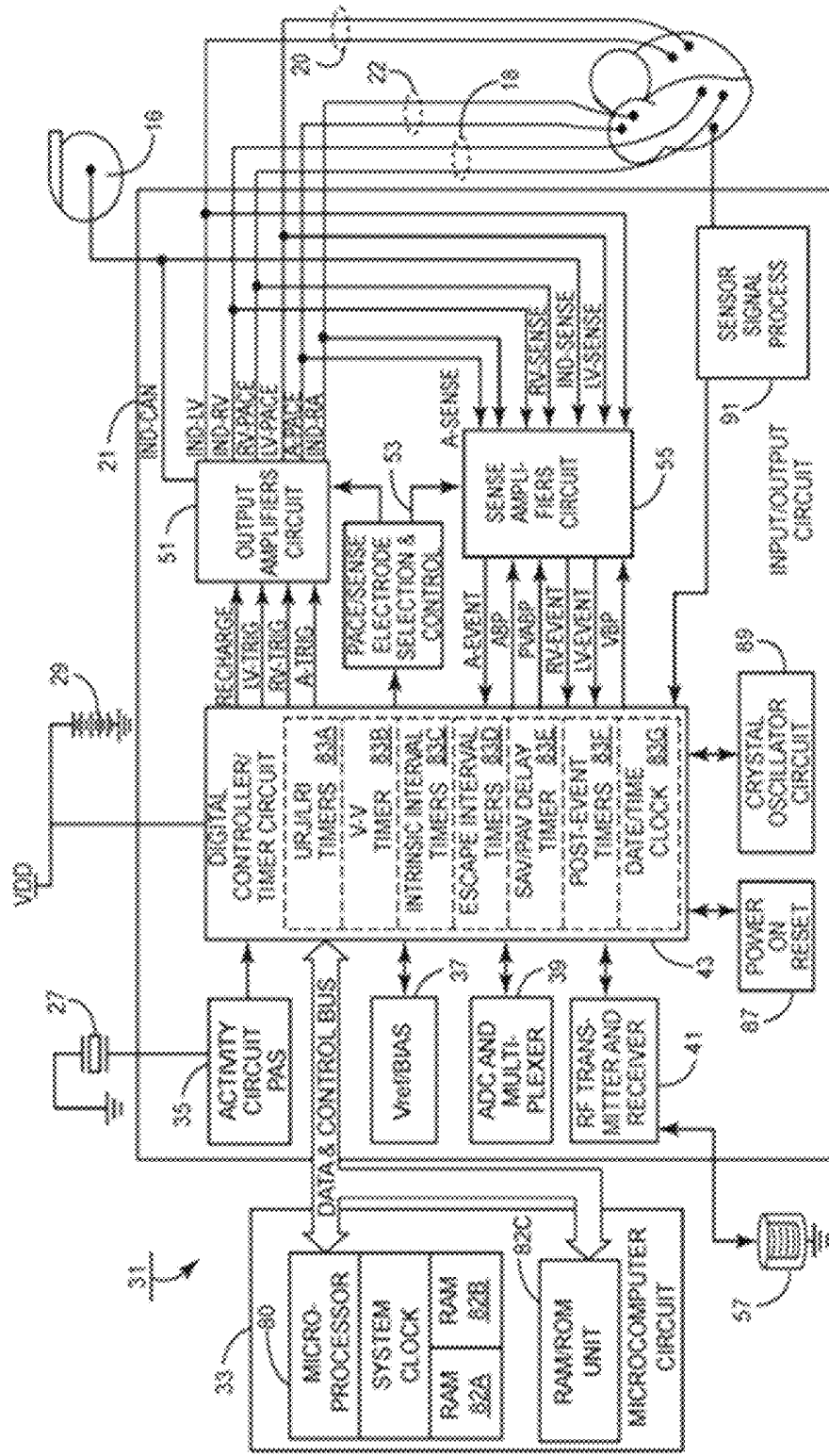

FIG. 9B



SYSTEMS AND METHODS FOR CONFIGURATION OF ATRIOVENTRICULAR INTERVAL

This application claims the benefit of U.S. Provisional Patent Application 62/037,700 entitled "Systems and Methods for Configuration of Atrioventricular Interval" and filed on Aug. 15, 2014, which is incorporated herein by reference in its entirety.

The disclosure herein relates to systems and methods for use in the configuration (e.g., optimization) of atrioventricular interval, or delay, for cardiac therapy being performed on a patient.

Cardiac therapy, such as cardiac resynchronization therapy (CRT), may correct symptoms of electrical dyssynchrony of a patient's heart by providing pacing therapy to one or both ventricles or atria, e.g., by providing pacing for earlier activation of the left or right ventricles and/or the left or right atrium while maintaining atrioventricular (A-V) synchrony. In effect, such therapy may provide effective, coordinated pumping action of the heart and effective cardiac function.

Providing cardiac therapy to a patient may involve determining effective programming of device parameters. For example, the selection of the timing of the pacing pulses delivered to the electrodes, such as atrioventricular (A-V) and interventricular (V-V) intervals, or delays, may be adjusted to deliver effective and/or optimal pacing therapy. Left univentricular pacing, or left ventricular-only pacing, includes only pacing (e.g., delivery of electrical stimulation) the left ventricle without pacing electrodes in the right ventricle.

Cardiac resynchronization devices may include three leads such as, e.g., one lead in the atrium (e.g., the right atrium), one lead in the right ventricle that is used for ventricular sensing and pacing (e.g., if required), and one lead in the left ventricle. Further, two-lead pacing systems with a sensing and pacing lead in the atrium and a sensing and pacing lead in the left ventricle may also be used for delivering cardiac resynchronization therapy through left ventricular only pacing.

Atrioventricular timing for cardiac resynchronization therapy may be optimized periodically for a standard three-lead device based on periodic measurements of intrinsic atrioventricular timing where intrinsic atrioventricular timing is determined by the time interval between an atrial sensing or pacing event and corresponding ventricular sensing from the right ventricular lead. Such optimization methods would not apply to a two-lead pacing system because such systems do not have electrode for right ventricular sensing. Moreover, there may be other forms of cardiac resynchronization therapy systems, for example, leadless cardiac resynchronization systems, which perform atrial and ventricular sensing from extracardiac devices and uses such sensing (e.g., timings) to trigger pacing from a leadless pacemaker implanted in the left ventricle or leadless pacers implanted in both left and right ventricles.

Exemplary cardiac therapy may use two or more A-V intervals such as, e.g., a paced AV interval, or delay, (PAV) and a sensed AV delay, or delay, (SAV). The PAV is an adjustable time period between a paced atrial event and a paced ventricular event (e.g., where a device may optimally deliver a ventricular pace), and the SAV is an adjustable time period between a sensed atrial event and a paced ventricular event.

SUMMARY

The exemplary systems, methods, and interfaces described herein may be configured to assist a user (e.g., a

physician) in configuring cardiac therapy (e.g., cardiac therapy being performed on a patient during and/or after implantation of cardiac therapy apparatus). The systems, methods, and interfaces may be described as being noninvasive. For example, the systems, methods, and interfaces may not need implantable devices such as leads, probes, sensors, catheters, etc. to evaluate and configure the cardiac therapy. Instead, the systems, methods, and interfaces may use electrical measurements taken noninvasively using, e.g., a plurality of external electrodes attached to the skin of a patient about the patient's torso.

The exemplary systems and methods may monitor electrical activity using a plurality of external electrodes during the delivery of cardiac therapy using a plurality of different A-V intervals. The electrical activity may be used to generate electrical heterogeneity information (e.g., data) representative of mechanical cardiac functionality and/or electrical cardiac functionality of the patient for each of the plurality of different A-V intervals. One or more of the A-V intervals may be identified based on the electrical heterogeneity information (e.g., data) for each of the plurality of different A-V intervals.

The exemplary systems and methods can be applied to optimize atrioventricular timing for CRT therapy for any form of cardiac resynchronization device that has the capability to sense atrial activity either directly from the atrium or from extracardiac systems like a subcutaneous devices and sense ventricular activity from a ventricular electrode or from an extracardiac system.

One exemplary system for use in cardiac therapy may include electrode apparatus and computing apparatus coupled to the electrode apparatus. The electrode apparatus may include a plurality of external electrodes configured to be located proximate tissue of a patient (e.g., surface electrodes positioned in an array configured to be located proximate the skin of the torso of the patient). The computing apparatus may be configured to initiate delivery of left ventricular pacing therapy at a plurality of different A-V intervals. The left ventricular pacing therapy may be delivered using at least one pacing electrode configured to pace the patient's left ventricle and without any sensing and/or pacing electrodes located in the patient's right ventricle. The computing apparatus may be further configured to monitor electrical activity using the plurality of external electrodes during the delivery of left ventricular pacing therapy, generate electrical heterogeneity information (e.g., data) representative of at least one of mechanical cardiac functionality and electrical cardiac functionality (e.g., at least one metric of global or local surrogate electrical heterogeneity) for each of the plurality of different A-V intervals based on the monitored electrical activity, and identify an A-V interval from the plurality of different A-V intervals based on the electrical heterogeneity information (e.g., data).

One exemplary method for use in cardiac therapy may include initiating delivery of left ventricular pacing therapy at a plurality of different A-V intervals. The left ventricular pacing therapy is delivered using at least one pacing electrode configured to pace the patient's left ventricle and without any sensing and/or pacing electrodes located in the patient's right ventricle. The exemplary method may further include monitoring electrical activity using a plurality of external electrodes (e.g., surface electrodes positioned in an array configured to be located proximate the skin of the torso of the patient) during the delivery of left ventricular pacing therapy, generating electrical heterogeneity information representative of at least one of mechanical cardiac functionality and electrical cardiac functionality for each of the

plurality of different A-V intervals based on the monitored electrical activity, and identifying an A-V interval from the plurality of different A-V intervals based on the electrical heterogeneity information.

One exemplary system for use in cardiac therapy may include electrode means and computing means. The electrode means may include a plurality of external electrodes configured to be located proximate tissue of a patient (e.g., surface electrodes positioned in an array configured to be located proximate the skin of the torso of the patient). The computing means may be for initiating delivery of left ventricular pacing therapy at a plurality of different A-V intervals, where the left ventricular pacing therapy is delivered using at least one pacing electrode configured to pace the patient's left ventricle and without any sensing and/or pacing electrodes located in the patient's right ventricle. The computing means may be further for monitoring electrical activity using a plurality of external electrodes during the delivery of left ventricular pacing therapy, generating electrical heterogeneity information representative of at least one of mechanical cardiac functionality and electrical cardiac functionality (e.g., at least one metric of global or local surrogate electrical heterogeneity) for each of the plurality of different A-V intervals based on the monitored electrical activity, and identifying an A-V interval from the plurality of different A-V intervals based on the electrical heterogeneity information.

One exemplary system for use in cardiac therapy may include electrode apparatus and computing apparatus coupled to the electrode apparatus. The electrode apparatus may include a plurality of external electrodes configured to be located proximate tissue of a patient (e.g., surface electrodes positioned in an array configured to be located proximate the skin of the torso of the patient). The computing apparatus may be configured to initiate delivery of left ventricular pacing therapy at a plurality of different A-V intervals (e.g., pacing therapy is delivered using at least one pacing electrode configured to pace the patient's left ventricular and without any sensing and/or pacing electrodes located in the patient's right ventricle), monitor electrical activity using the plurality of external electrodes during the delivery of left ventricular pacing therapy, generate electrical heterogeneity information representative of at least one of mechanical cardiac functionality and electrical cardiac functionality (e.g., at least one metric of global or local surrogate electrical heterogeneity) for each of the plurality of different A-V intervals based on the monitored electrical activity, identify an A-V interval from the plurality of different A-V intervals based on the electrical heterogeneity information, and determine a difference value for use in adjusting the A-V interval during left ventricular pacing therapy based on the identified A-V interval and an intrinsic A-V conduction time. In at least one embodiment, the difference value is configured to be used periodically during the delivery of left ventricular pacing therapy such that, periodically, a patient's intrinsic A-V conduction time is measured and the difference value may be applied to the measured intrinsic A-V conduction time to provide the A-V interval used in the delivery of pacing therapy. Further, if the provided A-V interval is greater than or equal to a threshold value, the provided A-V interval may not be used in the delivery of pacing therapy.

One exemplary method for use in cardiac therapy may include initiating delivery of left ventricular pacing therapy at a plurality of different A-V intervals (e.g., pacing therapy is delivered using at least one pacing electrode configured to pace the patient's left ventricular and without any sensing

and/or pacing electrodes located in the patient's right ventricle), monitoring electrical activity using a plurality of external electrodes (e.g., surface electrodes positioned in an array configured to be located proximate the skin of the torso of the patient) during the delivery of left ventricular pacing therapy, generating electrical heterogeneity information representative of at least one of mechanical cardiac functionality and electrical cardiac functionality (e.g., at least one metric of global or local surrogate electrical heterogeneity) for each of the plurality of different A-V intervals based on the monitored electrical activity, identifying an A-V interval from the plurality of different A-V intervals based on the electrical heterogeneity information, and determining a difference value for use in adjusting the A-V interval during left ventricular pacing therapy based on the identified A-V interval and an intrinsic A-V conduction time. In at least one embodiment, the difference value is configured to be used periodically during the delivery of left ventricular pacing therapy such that, periodically, a patient's intrinsic A-V conduction time is measured and the difference value may be applied to the measured intrinsic A-V conduction time to provide the A-V interval used in the delivery of pacing therapy. Further, if the provided A-V interval is greater than or equal to a threshold value, the provided A-V interval may not be used in the delivery of pacing therapy.

One exemplary system for use in cardiac therapy may include electrode means and computing means. The electrode means may include a plurality of external electrodes configured to be located proximate tissue of a patient (e.g., surface electrodes positioned in an array configured to be located proximate the skin of the torso of the patient). The computing means may be for initiating delivery of left ventricular pacing therapy at a plurality of different A-V intervals (e.g., pacing therapy is delivered using at least one pacing electrode configured to pace the patient's left ventricular and without any sensing and/or pacing electrodes located in the patient's right ventricle), monitoring electrical activity using a plurality of external electrodes during the delivery of left ventricular pacing therapy, generating electrical heterogeneity information representative of at least one of mechanical cardiac functionality and electrical cardiac functionality (e.g., at least one metric of global or local surrogate electrical heterogeneity) for each of the plurality of different A-V intervals based on the monitored electrical activity, identifying an A-V interval from the plurality of different A-V intervals based on the electrical heterogeneity information, and determining a difference value for use in adjusting the A-V interval during left ventricular pacing therapy based on the identified A-V interval and an intrinsic A-V conduction time. In at least one embodiment, the difference value is configured to be used periodically during the delivery of left ventricular pacing therapy such that, periodically, a patient's intrinsic A-V conduction time is measured and the difference value may be applied to the measured intrinsic A-V conduction time to provide the A-V interval used in the delivery of pacing therapy. Further, if the provided A-V interval is greater than or equal to a threshold value, the provided A-V interval may not be used in the delivery of pacing therapy.

In one or more embodiments, the plurality of different A-V intervals may include a plurality of paced A-V intervals (PAV) and a plurality of sensed A-V intervals (SAV).

In one or more embodiments, the electrical heterogeneity information may include a global standard deviation of surrogate electrical activation times monitored by the plurality of external electrodes, and identifying a A-V interval from the plurality of different A-V intervals based on the

electrical heterogeneity information may include identifying the A-V interval from the plurality of different A-V intervals that generated the lowest global standard deviation of surrogate electrical activation times.

In one or more embodiments, the electrical heterogeneity information may include a left standard deviation of surrogate electrical activation times monitored by the two or more left external electrodes, and identifying a A-V interval from the plurality of different A-V intervals based on the electrical heterogeneity information may include identifying the A-V interval from the plurality of different A-V intervals that generated the lowest left standard deviation.

In one or more embodiments, the electrical heterogeneity information may include a left average of surrogate electrical activation times monitored by the two or more left external electrodes, and identifying a A-V interval from the plurality of different A-V intervals based on the electrical heterogeneity information may include identifying the A-V interval from the plurality of different A-V intervals that generated the lowest left average.

In one or more embodiments, identifying an A-V interval from the plurality of different A-V intervals based on the electrical heterogeneity information may include identifying an A-V interval from the plurality of different A-V intervals based on a QRS duration metric for each A-V interval of the plurality of different A-V intervals.

In one or more embodiments, initiating delivery of left ventricular pacing therapy at a plurality of different A-V intervals may include setting the A-V interval to an initial A-V interval value, delivering left ventricular pacing therapy at the A-V interval, and periodically increasing the A-V interval by a selected increment until an intrinsic A-V conduction is sensed. In at least one embodiment, the initial A-V interval value is less than or equal to 60 milliseconds. In at least one embodiment, the selected increment is less than or equal to 20 milliseconds.

In one or more embodiments, display apparatus may include a graphical user interface configured to present information for use in evaluating and adjusting left ventricular cardiac therapy delivered to a patient and at least the identified A-V interval may be displayed on the graphical user interface.

The exemplary systems and methods described herein may be used to configure LV-DDD pacing with only a mono (left)-ventricular pace/sense lead and an atrial pace-sense lead or with leadless LV pacing in conjunction with atrial sensing capability. The exemplary systems and methods may be described as being simplified systems for delivering CRT in heart failure patients with left bundle branch block and intrinsic A-V (or P-R) that is less than about 230 milliseconds (ms). Such systems may not have any right ventricular pace/sensing electrodes or leads. The exemplary systems and methods may be configured to optimize resynchronization pacing timing parameters using atrial sensing and LV sensing timings in a closed loop fashion.

One embodiment may use optimization of the sensed AV delay (SAV) and paced AV delay (PAV) using analysis of ventricular activation from surface electrocardiogram (ECG) electrodes (e.g., ECG belt or best) for different SAV/PAV values sweeping the A-V spectrum from short A-V intervals (e.g., about 60 ms) until intrinsic activity is sensed either from a LV electrode or from an extracardiac sensing system. Further an optimal sensed/paced A-V timing may be determined based on the analysis and a difference between the optimal sensed/paced A-V timing and the corresponding atrial sense/atrial pace-to-left ventricular (As/Ap-Vs) sensed delay may be calculated, where Vs is the time

of the ventricular sense either from a LV electrode or from an extracardiac system. In one or more embodiments, the paced/sensed AV delay may be periodically optimized based on the periodic measurements of intrinsic As/Ap-Vs timings.

The exemplary systems and methods may be applied to one or more pacing devices that are implanted for resynchronization pacing in left bundle branch block patients with an A-V interval that is less than 230 ms. The pacing devices may have atrial sense and/or pace capabilities and left ventricular pace and/or sense capabilities. In at least one embodiment, the pacing device is a LV-DDD pacer with an atrial lead and a left ventricular lead (but no RV lead). In another embodiment, the pacing device is a leadless LV pacer with capabilities to sense and/or pace the atrium from a co-implanted system or from a special sensing tail from the leadless pacer, etc. In another embodiment, the pacing system may include tiny leadless pacing pellets with no sensing capabilities that are implanted in the LV or in both RV and LV, and that can be triggered by extracardiac systems that perform sensing of atrial and ventricular activity, and wireless communication with these pellets through acoustic, radiofrequency or other modes.

It may be described that the exemplary systems and methods may be generally configured to sweep the AV spectrum at different SAV/PAVs and, for each setting, compute parameters of resynchronization based on surface ECG analysis from at least one ECG electrode. In one embodiment, QRS duration based on a single ECG lead measurement or a co-implanted sub-cutaneous device providing sub-cutaneous ECG measurements may be used to provide cardiac resynchronization information for use in further configuring and/or optimizing the A-V interval.

A difference value between the optimal SAV/PAV intervals and intrinsic A-V conduction times, or atrial sense-to-ventricular sense timings, may be computed and saved. In another embodiment, a ratio value between the optimal SAV/PAV and intrinsic A-V conduction times or atrial sense-to-ventricular sense timings may be computed and saved. The exemplary pacing devices may be programmed to automatically evaluate intrinsic A-V conduction times periodically by pausing pacing and to adjust the SAV/PAV intervals by using difference value (e.g., a ratio) and the measured intrinsic A-V conduction times. In this way, the pacing device may maintain optimal cardiac resynchronization by changing SAV/PAV intervals in response to changes in intrinsic A-V conduction times. Further, the optimal SAV/PAV intervals for each patient may be evaluated in a patient-specific manner (as opposed to, e.g., population-based formulas, regression models, etc.).

The above summary is not intended to describe each embodiment or every implementation of the present disclosure. A more complete understanding will become apparent and appreciated by referring to the following detailed description and claims taken in conjunction with the accompanying drawings.

BRIEF DESCRIPTION OF THE DRAWINGS

FIG. 1 is a diagram of an exemplary system including electrode apparatus, display apparatus, and computing apparatus.

FIGS. 2-3 are diagrams of exemplary external electrode apparatus for measuring torso-surface potentials.

FIG. 4 is a block diagram of an exemplary method for A-V interval identification.

FIG. 5 is a block diagram of an exemplary method for determining a difference value for use in A-V interval adjustment during pacing therapy.

FIG. 6 is a block diagram of an exemplary method for cardiac pacing therapy including A-V interval adjustment.

FIG. 7 is a diagram of an exemplary system including an exemplary implantable medical device (IMD).

FIG. 8A is a diagram of the exemplary IMD of FIG. 7.

FIG. 8B is a diagram of an enlarged view of a distal end of the electrical lead disposed in the left ventricle of FIG. 8A.

FIG. 9A is a block diagram of an exemplary IMD, e.g., the systems of FIGS. 7-8.

FIG. 9B is another block diagram of an exemplary IMD (e.g., an implantable pulse generator) circuitry and associated leads employed in the systems of FIGS. 7-8.

DETAILED DESCRIPTION OF EXEMPLARY EMBODIMENTS

In the following detailed description of illustrative embodiments, reference is made to the accompanying figures of the drawing which form a part hereof, and in which are shown, by way of illustration, specific embodiments which may be practiced. It is to be understood that other embodiments may be utilized and structural changes may be made without departing from (e.g., still falling within) the scope of the disclosure presented hereby.

Exemplary systems and methods shall be described with reference to FIGS. 1-9. It will be apparent to one skilled in the art that elements or processes from one embodiment may be used in combination with elements or processes of the other embodiments, and that the possible embodiments of such methods and systems using combinations of features set forth herein is not limited to the specific embodiments shown in the Figures and/or described herein. Further, it will be recognized that the embodiments described herein may include many elements that are not necessarily shown to scale. Still further, it will be recognized that timing of the processes and the size and shape of various elements herein may be modified but still fall within the scope of the present disclosure, although certain timings, one or more shapes and/or sizes, or types of elements, may be advantageous over others.

Cardiac electrical activation times can be detected or estimated in proximity of a reference location (e.g., which can be a chosen location for a left ventricle lead during implant) using unipolar electrocardiogram (ECG) recordings. The cardiac electrical activation times may be used to generate electrical heterogeneity information that may be used by a user (e.g., physician) to optimize one or more settings, or parameters, of pacing therapy. Further, the electrical activation times may be measured and displayed, or conveyed, to a user by a system. As described herein, electrical activation times and/or electrical heterogeneity information may be used in noninvasive configuration (e.g., optimization, adjustment, etc.) of cardiac therapy.

Various exemplary systems, methods, and interfaces may be configured to use electrode apparatus including external electrodes, display apparatus, and computing apparatus to noninvasively assist a user (e.g., a physician) in the configuration (e.g., optimization) of cardiac therapy. An exemplary system 100 including electrode apparatus 110, display apparatus 130, and computing apparatus 140 is depicted in FIG. 1.

The electrode apparatus 110 as shown includes a plurality of electrodes incorporated, or included, within a band

wrapped around the chest, or torso, of a patient 14. The electrode apparatus 110 is operatively coupled to the computing apparatus 140 (e.g., through one or wired electrical connections, wirelessly, etc.) to provide electrical signals from each of the electrodes to the computing apparatus 140 for analysis, evaluation, etc. Exemplary electrode apparatus may be described in U.S. patent application Ser. No. 14/227,719 entitled "Bioelectric Sensor Device and Methods" and filed Mar. 27, 2014, which is incorporated herein by reference in its entirety. Further, exemplary electrode apparatus 110 will be described in more detail in reference to FIGS. 2-3.

Although not described herein, the exemplary system 100 may further include imaging apparatus. The imaging apparatus may be any type of imaging apparatus configured to image, or provide images of, at least a portion of the patient in a noninvasive manner. For example, the imaging apparatus may not use any components or parts that may be located within the patient to provide images of the patient except noninvasive tools such as contrast solution. It is to be understood that the exemplary systems, methods, and interfaces described herein may further use imaging apparatus to provide noninvasive assistance to a user (e.g., a physician) to locate, or select, a pacing electrode or vector proximate the patient's heart in conjunction with the configuration of cardiac therapy.

For example, the exemplary systems, methods, and interfaces may provide image guided navigation that may be used to navigate leads including electrodes, leadless electrodes, wireless electrodes, catheters, etc., within the patient's body while also providing noninvasive cardiac therapy configuration including determining an effective, or optimal, A-V interval. Exemplary systems and methods that use imaging apparatus and/or electrode apparatus may be described in U.S. patent application Ser. No. 13/916,353 filed on Jun. 12, 2013 and entitled "Implantable Electrode Location Selection," U.S. patent application Ser. No. 13/916,377 filed on Jun. 12, 2013 and entitled "Implantable Electrode Location Selection," U.S. patent application Ser. No. 14/227,955 filed on Mar. 27, 2014 and entitled "Systems, Methods, and Interfaces for Identifying Effective Electrodes," U.S. patent application Ser. No. 14/227,919 filed on Mar. 27, 2014 and entitled "Systems, Methods, and Interfaces for Identifying Optimal Electrical Vectors," each of which is incorporated herein by reference in its entirety.

Exemplary imaging apparatus may be configured to capture x-ray images and/or any other alternative imaging modality. For example, the imaging apparatus may be configured to capture images, or image data, using isocentric fluoroscopy, bi-plane fluoroscopy, ultrasound, computed tomography (CT), multi-slice computed tomography (MSCT), magnetic resonance imaging (MRI), high frequency ultrasound (HIFU), optical coherence tomography (OCT), intra-vascular ultrasound (IVUS), two dimensional (2D) ultrasound, three dimensional (3D) ultrasound, four dimensional (4D) ultrasound, intraoperative CT, intraoperative MRI, etc. Further, it is to be understood that the imaging apparatus may be configured to capture a plurality of consecutive images (e.g., continuously) to provide video frame data. In other words, a plurality of images taken over time using the imaging apparatus may provide video frame, or motion picture, data. Additionally, the images may also be obtained and displayed in two, three, or four dimensions. In more advanced forms, four-dimensional surface rendering of the heart or other regions of the body may also be achieved by incorporating heart data or other soft tissue data from a map or from pre-operative image data captured by

MRI, CT, or echocardiography modalities. Image datasets from hybrid modalities, such as positron emission tomography (PET) combined with CT, or single photon emission computer tomography (SPECT) combined with CT, could also provide functional image data superimposed onto anatomical data, e.g., to be used to navigate implantable apparatus to target locations within the heart or other areas of interest.

Systems and/or imaging apparatus that may be used in conjunction with the exemplary systems and method described herein are described in U.S. Pat. App. Pub. No. 2005/0008210 to Evron et al. published on Jan. 13, 2005, U.S. Pat. App. Pub. No. 2006/0074285 to Zarkh et al. published on Apr. 6, 2006, U.S. Pat. App. Pub. No. 2011/0112398 to Zarkh et al. published on May 12, 2011, U.S. Pat. App. Pub. No. 2013/0116739 to Brada et al. published on May 9, 2013, U.S. Pat. No. 6,980,675 to Evron et al. issued on Dec. 27, 2005, U.S. Pat. No. 7,286,866 to Okerlund et al. issued on Oct. 23, 2007, U.S. Pat. No. 7,308,297 to Reddy et al. issued on Dec. 11, 2011, U.S. Pat. No. 7,308,299 to Burrell et al. issued on Dec. 11, 2011, U.S. Pat. No. 7,321,677 to Evron et al. issued on Jan. 22, 2008, U.S. Pat. No. 7,346,381 to Okerlund et al. issued on Mar. 18, 2008, U.S. Pat. No. 7,454,248 to Burrell et al. issued on Nov. 18, 2008, U.S. Pat. No. 7,499,743 to Vass et al. issued on Mar. 3, 2009, U.S. Pat. No. 7,565,190 to Okerlund et al. issued on Jul. 21, 2009, U.S. Pat. No. 7,587,074 to Zarkh et al. issued on Sep. 8, 2009, U.S. Pat. No. 7,599,730 to Hunter et al. issued on Oct. 6, 2009, U.S. Pat. No. 7,613,500 to Vass et al. issued on Nov. 3, 2009, U.S. Pat. No. 7,742,629 to Zarkh et al. issued on Jun. 22, 2010, U.S. Pat. No. 7,747,047 to Okerlund et al. issued on Jun. 29, 2010, U.S. Pat. No. 7,778,685 to Evron et al. issued on Aug. 17, 2010, U.S. Pat. No. 7,778,686 to Vass et al. issued on Aug. 17, 2010, U.S. Pat. No. 7,813,785 to Okerlund et al. issued on Oct. 12, 2010, U.S. Pat. No. 7,996,063 to Vass et al. issued on Aug. 9, 2011, U.S. Pat. No. 8,060,185 to Hunter et al. issued on Nov. 15, 2011, and U.S. Pat. No. 8,401,616 to Verard et al. issued on Mar. 19, 2013, each of which is incorporated herein by reference in its entirety.

The display apparatus **130** and the computing apparatus **140** may be configured to display and analyze data such as, e.g., electrical signals (e.g., electrocardiogram data), electrical heterogeneity information, etc. Electrical heterogeneity information, or electrical dyssynchrony information, may be representative of at least one of mechanical cardiac functionality and electrical cardiac functionality, surrogate electrical activation information or data, etc. that is generated using electrical signals gathered, monitored, or collected, using the electrode apparatus **110**. In at least one embodiment, the computing apparatus **140** may be a server, a personal computer, or a tablet computer. The computing apparatus **140** may be configured to receive input from input apparatus **142** and transmit output to the display apparatus **130**. Further, the computing apparatus **140** may include data storage that may allow for access to processing programs or routines and/or one or more other types of data, e.g., for driving a graphical user interface configured to noninvasively assist a user in configuring one or more pacing parameters, or settings, such as, e.g., A-V interval, V-V interval, etc.

The computing apparatus **140** may be operatively coupled to the input apparatus **142** and the display apparatus **130** to, e.g., transmit data to and from each of the input apparatus **142** and the display apparatus **130**. For example, the computing apparatus **140** may be electrically coupled to each of the input apparatus **142** and the display apparatus **130** using,

e.g., analog electrical connections, digital electrical connections, wireless connections, bus-based connections, network-based connections, internet-based connections, etc. As described further herein, a user may provide input to the input apparatus **142** to view and/or select one or more pieces of configuration information related to the cardiac therapy.

Although as depicted the input apparatus **142** is a keyboard, it is to be understood that the input apparatus **142** may include any apparatus capable of providing input to the computing apparatus **140** to perform the functionality, methods, and/or logic described herein. For example, the input apparatus **142** may include a mouse, a trackball, a touchscreen (e.g., capacitive touchscreen, a resistive touchscreen, a multi-touch touchscreen, etc.), etc. Likewise, the display apparatus **130** may include any apparatus capable of displaying information to a user, such as a graphical user interface **132** including one or more pacing parameters, electrical heterogeneity information, textual instructions, graphical depictions of electrical activation information, graphical depictions of anatomy of a human heart, images or graphical depictions of the patient's heart, graphical depictions of locations of one or more electrodes, graphical depictions of a human torso, images or graphical depictions of the patient's torso, graphical depictions or actual images of implanted electrodes and/or leads, etc. Further, the display apparatus **130** may include a liquid crystal display, an organic light-emitting diode screen, a touchscreen, a cathode ray tube display, etc.

The processing programs or routines stored and/or executed by the computing apparatus **140** may include programs or routines for computational mathematics, matrix mathematics, decomposition algorithms, compression algorithms (e.g., data compression algorithms), calibration algorithms, image construction algorithms, signal processing algorithms (e.g., various filtering algorithms, Fourier transforms, fast Fourier transforms, etc.), standardization algorithms, comparison algorithms, vector mathematics, or any other processing required to implement one or more exemplary methods and/or processes described herein. Data stored and/or used by the computing apparatus **140** may include, for example, electrical signal/waveform data from the electrode apparatus **110**, electrical activation times from the electrode apparatus **110**, graphics (e.g., graphical elements, icons, buttons, windows, dialogs, pull-down menus, graphic areas, graphic regions, 3D graphics, etc.), graphical user interfaces, results from one or more processing programs or routines employed according to the disclosure herein (e.g., electrical signals, electrical heterogeneity information, etc.), or any other data that may be necessary for carrying out the one and/or more processes or methods described herein.

In one or more embodiments, the exemplary systems, methods, and interfaces may be implemented using one or more computer programs executed on programmable computers, such as computers that include, for example, processing capabilities, data storage (e.g., volatile or non-volatile memory and/or storage elements), input devices, and output devices. Program code and/or logic described herein may be applied to input data to perform functionality described herein and generate desired output information. The output information may be applied as input to one or more other devices and/or methods as described herein or as would be applied in a known fashion.

The one or more programs used to implement the systems, methods, and/or interfaces described herein may be provided using any programmable language, e.g., a high level procedural and/or object orientated programming language

that is suitable for communicating with a computer system. Any such programs may, for example, be stored on any suitable device, e.g., a storage media, that is readable by a general or special purpose program running on a computer system (e.g., including processing apparatus) for configuring and operating the computer system when the suitable device is read for performing the procedures described herein. In other words, at least in one embodiment, the exemplary systems, methods, and/or interfaces may be implemented using a computer readable storage medium, configured with a computer program, where the storage medium so configured causes the computer to operate in a specific and predefined manner to perform functions described herein. Further, in at least one embodiment, the exemplary systems, methods, and/or interfaces may be described as being implemented by logic (e.g., object code) encoded in one or more non-transitory media that includes code for execution and, when executed by a processor, is operable to perform operations such as the methods, processes, and/or functionality described herein.

The computing apparatus **140** may be, for example, any fixed or mobile computer system (e.g., a controller, a micro-controller, a personal computer, mini computer, tablet computer, etc.). The exact configuration of the computing apparatus **140** is not limiting, and essentially any device capable of providing suitable computing capabilities and control capabilities (e.g., graphics processing, etc.) may be used. As described herein, a digital file may be any medium (e.g., volatile or non-volatile memory, a CD-ROM, a punch card, magnetic recordable tape, etc.) containing digital bits (e.g., encoded in binary, trinary, etc.) that may be readable and/or writeable by computing apparatus **140** described herein. Also, as described herein, a file in user-readable format may be any representation of data (e.g., ASCII text, binary numbers, hexadecimal numbers, decimal numbers, graphically, etc.) presentable on any medium (e.g., paper, a display, etc.) readable and/or understandable by a user.

In view of the above, it will be readily apparent that the functionality as described in one or more embodiments according to the present disclosure may be implemented in any manner as would be known to one skilled in the art. As such, the computer language, the computer system, or any other software/hardware which is to be used to implement the processes described herein shall not be limiting on the scope of the systems, processes or programs (e.g., the functionality provided by such systems, processes or programs) described herein.

Electrical activation times of the patient's heart may be useful to evaluate cardiac therapy being delivered to a patient. Surrogate electrical activation information or data of one or more regions of a patient's heart may be monitored, or determined, using electrode apparatus **110** as shown in FIG. 1 and in FIGS. 2-3. The exemplary electrode apparatus **110** may be configured to measure body-surface potentials of a patient **14** and, more particularly, torso-surface potentials of a patient **14**. As shown in FIG. 2, the exemplary electrode apparatus **110** may include a set, or array, of electrodes **112**, a strap **113**, and interface/amplifier circuitry **116**. The electrodes **112** may be attached, or coupled, to the strap **113** and the strap **113** may be configured to be wrapped around the torso of a patient **14** such that the electrodes **112** surround the patient's heart. As further illustrated, the electrodes **112** may be positioned around the circumference of a patient **14**, including the posterior, lateral, posterolateral, anterolateral, and anterior locations of the torso of a patient **14**.

Further, the electrodes **112** may be electrically connected to interface/amplifier circuitry **116** via wired connection **118**. The interface/amplifier circuitry **116** may be configured to amplify the signals from the electrodes **112** and provide the signals to the computing apparatus **140**. Other exemplary systems may use a wireless connection to transmit the signals sensed by electrodes **112** to the interface/amplifier circuitry **116** and, in turn, the computing apparatus **140**, e.g., as channels of data. For example, the interface/amplifier circuitry **116** may be electrically coupled to each of the computing apparatus **140** and the display apparatus **130** using, e.g., analog electrical connections, digital electrical connections, wireless connections, bus-based connections, network-based connections, internet-based connections, etc.

Although in the example of FIG. 2 the electrode apparatus **110** includes a strap **113**, in other examples any of a variety of mechanisms, e.g., tape or adhesives, may be employed to aid in the spacing and placement of electrodes **112**. In some examples, the strap **113** may include an elastic band, strip of tape, or cloth. In other examples, the electrodes **112** may be placed individually on the torso of a patient **14**. Further, in other examples, electrodes **112** (e.g., arranged in an array) may be part of, or located within, patches, vests, and/or other manners of securing the electrodes **112** to the torso of the patient **14**. Still further, in other examples, the electrodes **112** may be part of, or located within, two sections of material or two "patches." One of the two sections or patches may be located on the anterior side of the torso of the patient **14** (to, e.g., monitor electrical signals representative of the anterior side of the patient's heart, measure surrogate cardiac electrical activation times representative of the anterior side of the patient's heart, etc.) and the other section or patch may be located on the posterior side of the torso of the patient **14** (to, e.g., monitor electrical signals representative of the posterior side of the patient's heart, measure surrogate cardiac electrical activation times representative of the posterior side of the patient's heart, etc.).

The electrodes **112** may be configured to surround the heart of the patient **14** and record, or monitor, the electrical signals associated with the depolarization and repolarization of the heart after the signals have propagated through the torso of a patient **14**. Each of the electrodes **112** may be used in a unipolar configuration to sense the torso-surface potentials that reflect the cardiac signals. The interface/amplifier circuitry **116** may also be coupled to a return or indifferent electrode (not shown) that may be used in combination with each electrode **112** for unipolar sensing. In some examples, there may be about 12 to about 50 electrodes **112** spatially distributed around the torso of a patient. Other configurations may have more or fewer electrodes **112**.

The computing apparatus **140** may record and analyze the torso-surface potential signals sensed by electrodes **112** and amplified/conditioned by the interface/amplifier circuitry **116**. The computing apparatus **140** may be configured to analyze the signals from the electrodes **112** to provide surrogate electrical activation information or data such as surrogate cardiac electrical activation times, e.g., representative of actual, or local, electrical activation times of one or more regions of the patient's heart as will be further described herein. For example, electrical signals measured at the left anterior surface location of a patient's torso may be representative, or surrogates, of electrical signals of the left anterior left ventricle region of the patient's heart, electrical signals measured at the left lateral surface location of a patient's torso may be representative, or surrogates, of electrical signals of the left lateral left ventricle region of the patient's heart, electrical signals measured at the left poste-

rolateral surface location of a patient's torso may be representative, or surrogates, of electrical signals of the posterolateral left ventricle region of the patient's heart, and electrical signals measured at the posterior surface location of a patient's torso may be representative, or surrogates, of electrical signals of the posterior left ventricle region of the patient's heart. In one or more embodiments, measurement of activation times can be performed by measuring the period of time between an onset of cardiac depolarization (e.g., onset of QRS complex) and the next onset of cardiac depolarization. In one or more embodiments, measurement of activation times can be performed by picking an appropriate fiducial point (e.g., peak values, minimum values, minimum slopes, maximum slopes, zero crossings, threshold crossings, etc. of a near or far-field EGM) and measuring time between fiducial points (e.g., within the electrical activity).

Additionally, the computing apparatus **140** may be configured to provide graphical user interfaces depicting the surrogate electrical activation times obtained using the electrode apparatus **110**. Exemplary systems, methods, and/or interfaces may noninvasively use the electrical information collected using the electrode apparatus **110** to evaluate and configure cardiac therapy being delivered to the patient.

FIG. **3** illustrates another exemplary electrode apparatus **110** that includes a plurality of electrodes **112** configured to surround the heart of the patient **14** and record, or monitor, the electrical signals associated with the depolarization and repolarization of the heart after the signals have propagated through the torso of the patient **14**. The electrode apparatus **110** may include a vest **114** upon which the plurality of electrodes **112** may be attached, or to which the electrodes **112** may be coupled. In at least one embodiment, the plurality, or array, of electrodes **112** may be used to collect electrical information such as, e.g., surrogate electrical activation times. Similar to the electrode apparatus **110** of FIG. **2**, the electrode apparatus **110** of FIG. **3** may include interface/amplifier circuitry **116** electrically coupled to each of the electrodes **112** through a wired connection **118** and be configured to transmit signals from the electrodes **112** to computing apparatus **140**. As illustrated, the electrodes **112** may be distributed over the torso of a patient **14**, including, for example, the posterior, lateral, posterolateral, anterolateral, and anterior locations of the torso of a patient **14**.

The vest **114** may be formed of fabric with the electrodes **112** attached to the fabric. The vest **114** may be configured to maintain the position and spacing of electrodes **112** on the torso of the patient **14**. Further, the vest **114** may be marked to assist in determining the location of the electrodes **112** on the surface of the torso of the patient **14**. In some examples, there may be about 25 to about 256 electrodes **112** distributed around the torso of the patient **14**, though other configurations may have more or fewer electrodes **112**.

As described herein, the electrode apparatus **110** may be configured to measure electrical information (e.g., electrical signals) representing different regions of a patient's heart. For example, activation times of different regions of a patient's heart can be approximated from surface electrocardiogram (ECG) activation times measured using surface electrodes in proximity to surface areas corresponding to the different regions of the patient's heart.

The exemplary systems and methods may be used to provide noninvasive assistance to a user in the evaluation and configuration of cardiac therapy (e.g., cardiac therapy being presently-delivered to a patient during implantation or after implantation). For example, the exemplary systems and methods may be used to assist a user in the configuration

and/or adjustment of one or more cardiac therapy settings for the cardiac therapy being delivered to a patient. Specifically, the exemplary systems and methods may provide optimization of the A-V interval, or delay, of pacing therapy (e.g., left univentricular pacing therapy).

The exemplary systems and methods may be configured to identify and/or optimize the A-V interval (e.g., for left univentricular pacing, or left ventricular-only pacing, therapy). The pacing therapy may include left ventricular pacing therapy that is delivered using at least one pacing electrode (e.g., coupled to a lead, leadless, etc.) configured to pace the patient's left ventricle. In one or more embodiments, the pacing therapy may be left univentricular pacing, e.g., left ventricular pacing without any electrodes located in the patient's right ventricle for pacing or sensing purposes. Although it is often described herein that the exemplary systems and methods may be configured to identify and/or optimize the A-V interval for left univentricular pacing therapy, it is to be understood that the exemplary systems and methods may be used with any other therapy system, device, or method where the exemplary systems and methods may be useful including pacing systems and methods that include a right ventricular sensing and/or pacing electrodes.

Exemplary method **200** depicted in FIG. **4** may be used to provide the A-V interval identification and/or optimization. The exemplary method **200** may be generally described to be used in the noninvasive evaluation and configuration (e.g., optimization) of cardiac therapy. The exemplary method **200** may be described as being noninvasive because the method does not use invasive apparatus to perform the evaluation and configuration of the cardiac therapy. The cardiac therapy being delivered, however, may be described as being invasive such as when, e.g., one or more pacing electrodes are implanted proximate a patient's heart. The exemplary method **200** may be used to evaluate and configure such invasive cardiac therapy.

The exemplary method **200** may include monitoring, or measuring, electrical activity using a plurality of external electrodes **202**. The plurality of external electrodes may be similar to the external electrodes provided by the electrode apparatus **110** as described herein with respect to FIGS. **1-3**. For example, the plurality of external electrodes may be part, or incorporated into, a vest or band that is located about a patient's torso. More specifically, the plurality of electrodes may be described as being surface electrodes positioned in an array configured to be located proximate the skin of the torso of a patient. The electrical activity monitored during process **202** prior to the delivery of cardiac therapy may be referred to as "baseline" electrical activity because no therapy is delivered to the patient such that the patient's heart is in its natural, or intrinsic, rhythm.

During, or simultaneous with, the monitoring, or collecting, of electrical activity **202**, the exemplary method **200** may initiate the delivery of cardiac therapy **204** such as, e.g., left univentricular pacing therapy. The cardiac therapy **204** may be delivered by at least one electrode configured to electrically stimulate (e.g., depolarize, pace, etc.) the patient's left ventricle after either an atrial sense or atrial pace. The cardiac therapy may be delivered to the left ventricle using an A-V interval or delay, which is the time period between an atrial event (e.g., paced depolarization or intrinsic depolarization) and the left ventricular pace.

In at least one embodiment, each of the electrodes may be coupled to one or more leads implanted in, or proximate to, the patient's heart. Further, in at least one embodiment, the cardiac therapy **204** may be delivered by a lead-less elec-

trode. Exemplary cardiac therapy using an implantable electrode and lead may be further described herein with reference to FIGS. 7-9. Although the systems and devices of FIGS. 7-9 include three leads, it is to be understood that the exemplary systems and methods described herein may be used with any type of cardiac pacing systems including no leads, less than three leads, and more than three leads. As described herein, although the cardiac therapy delivery may be described as being invasive, the exemplary methods and systems may be described as being noninvasive because the exemplary methods and systems may only initiate the delivery of and configure the cardiac therapy, and the exemplary methods and systems may further use electrical signals that are monitored, or taken, from the patient noninvasively.

The monitored electrical activity may be used to generate electrical heterogeneity information 206. The electrical heterogeneity information may be described as information, or data, representative of at least one of mechanical cardiac functionality and electrical cardiac functionality. Electrical heterogeneity information and other cardiac therapy information may be described in U.S. Provisional Patent Application No. 61/834,133 entitled "METRICS OF ELECTRICAL DYSSYNCHRONY AND ELECTRICAL ACTIVATION PATTERNS FROM SURFACE ECG ELECTRODES" and filed on Jun. 12, 2013, which is hereby incorporated by reference it its entirety.

Electrical heterogeneity information (e.g., data) may be defined as information indicative of at least one of mechanical synchrony or dyssynchrony of the heart and/or electrical synchrony or dyssynchrony of the heart. In other words, electrical heterogeneity information may represent a surrogate of actual mechanical and/or electrical functionality of a patient's heart. In at least one embodiment, relative changes in electrical heterogeneity information (e.g., from baseline heterogeneity information to therapy heterogeneity information, from a first set of heterogeneity information to a second set of therapy heterogeneity information, etc.) may be used to determine a surrogate value representative of the changes in hemodynamic response (e.g., acute changes in LV pressure gradients). The left ventricular pressure may be typically monitored invasively with a pressure sensor located in the left ventricular of a patient's heart. As such, the use of electrical heterogeneity information to determine a surrogate value representative of the left ventricular pressure may avoid invasive monitoring using a left ventricular pressure sensor.

In at least one embodiment, the electrical heterogeneity information may include a standard deviation of ventricular activation times measured using some or all of the external electrodes, e.g., of the electrode apparatus 110. Further, local, or regional, electrical heterogeneity information may include standard deviations and/or averages of activation times measured using electrodes located in certain anatomic areas of the torso. For example, external electrodes on the left side of the torso of a patient may be used to compute local, or regional, left electrical heterogeneity information.

The electrical heterogeneity information may be generated using one or more various systems and/or methods. For example, electrical heterogeneity information may be generated using an array, or a plurality, of surface electrodes and/or imaging systems as described in U.S. Pat. App. Pub. No. 2012/0283587 A1 published Nov. 8, 2012 and entitled "ASSESSING INTRA-CARDIAC ACTIVATION PATTERNS AND ELECTRICAL DYSSYNCHRONY," U.S. Pat. App. Pub. No. 2012/0284003 A1 published Nov. 8, 2012 and entitled "ASSESSING INTRA-CARDIAC ACTIVATION PATTERNS", and U.S. Pat. No. 8,180,428 B2

issued May 15, 2012 and entitled "METHODS AND SYSTEMS FOR USE IN SELECTING CARDIAC PACING SITES," each of which is incorporated herein by reference in its entirety.

Electrical heterogeneity information may include one or more metrics or indices. For example, one of the metrics, or indices, of electrical heterogeneity may be a standard deviation of activation times (SDAT) measured using some or all of the electrodes on the surface of the torso of a patient. In some examples, the SDAT may be calculated using the estimated cardiac activation times over the surface of a model heart.

Another metric, or index, of electrical heterogeneity may be a left standard deviation of surrogate electrical activation times (LVED) monitored by external electrodes located proximate the left side of a patient. Further, another metric, or index, of electrical heterogeneity may include an average of surrogate electrical activation times (LVAT) monitored by external electrodes located proximate the left side of a patient. The LVED and LVAT may be determined (e.g., calculated, computed, etc.) from electrical activity measured only by electrodes proximate the left side of the patient, which may be referred to as "left" electrodes. The left electrodes may be defined as any surface electrodes located proximate the left ventricle, which includes region to left of the patient's sternum and spine. In one embodiment, the left electrodes may include all anterior electrodes on the left of the sternum and all posterior electrodes to the left of the spine. In another embodiment, the left electrodes may include all anterior electrodes on the left of the sternum and all posterior electrodes. In yet another embodiment, the left electrodes may be designated based on the contour of the left and right sides of the heart as determined using imaging apparatus (e.g., x-ray, fluoroscopy, etc.).

Another exemplary metric, or index, of dyssynchrony may be a range of activation times (RAT) that may be computed as the difference between the maximum and the minimum torso-surface or cardiac activation times, e.g., overall, or for a region. The RAT reflects the span of activation times while the SDAT gives an estimate of the dispersion of the activation times from a mean. The SDAT also provides an estimate of the heterogeneity of the activation times, because if activation times are spatially heterogeneous, the individual activation times will be further away from the mean activation time, indicating that one or more regions of heart have been delayed in activation. In some examples, the RAT may be calculated using the estimated cardiac activation times over the surface of a model heart.

Another exemplary metric, or index, of electrical heterogeneity information may include estimates of a percentage of surface electrodes located within a particular region of interest for the torso or heart whose associated activation times are greater than a certain percentile, such as, for example the 70th percentile, of measured QRS complex duration or the determined activation times for surface electrodes. The region of interest may, e.g., be a posterior, left anterior, and/or left-ventricular region. The exemplary metric, or index, may be referred to as a percentage of late activation (PLAT). The PLAT may be described as providing an estimate of percentage of the region of interest, e.g., posterior and left-anterior area associated with the left ventricular area of heart, which activates late. A large value for PLAT may imply delayed activation of a substantial portion of the region, e.g., the left ventricle, and the potential benefit of electrical resynchronization through CRT by pre-exciting the late region, e.g., of left ventricle. In other

examples, the PLAT may be determined for other subsets of electrodes in other regions, such as a right anterior region to evaluate delayed activation in the right ventricle. Furthermore, in some examples, the PLAT may be calculated using the estimated cardiac activation times over the surface of a model heart for either the whole heart or for a particular region, e.g., left or right ventricle, of the heart.

In one or more embodiments, the electrical heterogeneity information may include indicators of favorable changes in global cardiac electrical activation such as, e.g., described in Sweeney et al., "Analysis of Ventricular Activation Using Surface Electrocardiography to Predict Left Ventricular Reverse Volumetric Remodeling During Cardiac Resynchronization Therapy," *Circulation*, 2010 Feb. 9, 121(5): 626-34 and/or Van Deursen, et al., "Vectorcardiography as a Tool for Easy Optimization of Cardiac Resynchronization Therapy in Canine LBBB Hearts," *Circulation Arrhythmia and Electrophysiology*, 2012 Jun. 1, 5(3): 544-52, each of which is incorporated herein by reference in its entirety. Heterogeneity information may also include measurements of improved cardiac mechanical function measured by imaging or other systems to track motion of implanted leads within the heart as, e.g., described in Ryu et al., "Simultaneous Electrical and Mechanical Mapping Using 3D Cardiac Mapping System: Novel Approach for Optimal Cardiac Resynchronization Therapy," *Journal of Cardiovascular Electrophysiology*, 2010 February, 21(2): 219-22, Sperzel et al., "Intraoperative Characterization of Interventricular Mechanical Dyssynchrony Using Electroanatomic Mapping System A Feasibility Study," *Journal of Interventional Cardiac Electrophysiology*, 2012 November, 35(2): 189-96, and/or U.S. Pat. App. Pub. No. 2009/0099619 A1 entitled "METHOD FOR OPTIMIZING CRT THERAPY" and published on Apr. 16, 2009, each of which is incorporated herein by reference in its entirety.

The electrical heterogeneity information may be generated **206** for electrical activity monitored without, or before the delivery of, cardiac therapy, which may be referred to as baseline electrical heterogeneity information, and for electrical activity monitored during pacing therapy delivered at one or more A-V intervals, which may be described as being therapy electrical heterogeneity information.

The exemplary method **200** may further adjust the A-V interval from the previous A-V interval **208**. The A-V interval value may be adjusted (e.g., increased or decreased) by a step size value from the previous value. In another embodiment, the A-V interval may be changed to be a different A-V interval such as an initial A-V interval value.

It may be described that the A-V interval is "swept" from an initial, short A-V interval until an intrinsic ventricular event (e.g., depolarization) is sensed, e.g., due to the A-V interval being adjusted to be too long. In at least one embodiment, the first, or initial, A-V interval may be about 60 milliseconds (ms). The first, or initial, A-V interval may be greater than or equal to about 25 ms, greater than or equal to about 35 ms, greater than or equal to about 45 ms, greater than or equal to about 55 ms, greater than or equal to about 65 ms, greater than or equal to about 75 ms, greater than or equal to about 85 ms, etc. Further, the first, or initial, A-V interval may be less than or equal to about 120 ms, less than or equal to about 100 ms, less than or equal to about 90 ms, less than or equal to about 80 ms, less than or equal to about 70 ms, less than or equal to about 60 ms, etc.

The A-V interval may be increased by a step size until an intrinsic ventricular event is sensed. As used herein, an "intrinsic" ventricular event or conduction is one that occurs or is conducted (e.g., across the AV node of the heart, from

the atria to the ventricles, etc.) naturally. In at least one embodiment, the step size, or increment, may be about 20 ms. The step size, or increment, may be greater than or about 5 ms, greater than or equal to about 10 ms, greater than or equal to about 15 ms, greater than or equal to about 20 ms, greater than or equal to about 25 ms, greater than or equal to about 30 ms, greater than or equal to about 45 ms, etc. Further, the step size, or increment, may be less than or equal to about 70 ms, less than or equal to about 60 ms, less than or equal to about 50 ms, less than or equal to about 40 ms, less than or equal to about 35 ms, less than or equal to about 30 ms, etc.

As shown, the exemplary method **200** may continue to deliver left univentricular pacing therapy **204**, monitor electrical activity **202**, and generate electrical heterogeneity information **206** for each adjusted A-V interval **208** until an intrinsic ventricular event is sensed **210**. In other words, the method **200** may continue repeating the same cycle for different A-V intervals **208** (e.g., monitoring electrical activity **202** and generating electrical heterogeneity information **206**) until an intrinsic ventricular event is sensed **210**.

It may be described that the exemplary methods and systems initiate delivery of left univentricular pacing therapy at a plurality of different A-V intervals **204** (e.g., a different A-V interval for each cycle) and monitor the electrical activity **202** for each of the plurality of A-V intervals. Further, electrical heterogeneity information representative of at least one of mechanical cardiac functionality and electrical cardiac functionality may be generated **208** for each of the plurality of A-V intervals.

After an intrinsic ventricular event is sensed (e.g., after the A-V interval becomes too long such that an intrinsic depolarization occurs before the ventricular pace is to occur according to the A-V interval), the exemplary method **200** may identify one or more (e.g., one, two, etc.) A-V intervals of the plurality of different A-V intervals **212** based on the generated electrical heterogeneity information.

To identify one or more A-V intervals from the plurality of different A-V intervals **212**, the exemplary method **200** may use one or more metrics or indices of electrical heterogeneity, alone or together. For example, the A-V interval that generated the lowest global standard deviation of surrogate electrical activation times (SDAT), the lowest left standard deviation (LVSD) and/or the lowest left average (LVAT) may be identified. The identified A-V interval may be referred to as an optimal, or optimized, and/or effective A-V interval because, e.g., the identified A-V interval may provide optimal and/or effective cardiac therapy according to the generated heterogeneity information.

When it is described that A-V intervals are identified, it is to be understood that the exemplary methods and systems may identify the A-V intervals in various different ways. For example, the identified A-V intervals may be displayed on a graphical user interface along with heterogeneity information. The heterogeneity information may be graphical and/or textual, and may include graphical maps of electrical activation times about one or more regions of the patient's torso and/or heart.

Additionally, the exemplary methods and systems may be further configured to select the identified A-V interval and program, or set, the cardiac therapy apparatus to use the identified A-V interval. In other embodiments, a user may use the exemplary systems and methods to program, or configure the cardiac therapy apparatus using the identified A-V interval as well as other parameters and settings.

The identified A-V interval may be used to provide a difference value that may be used during the delivery of

pace therapy to adjust the A-V interval such that, e.g., the A-V interval tracks with, or corresponds to, an activity level of the patient, a heart rate of the patient, etc. The difference value may be a time offset, a time period, a ratio, a percentage, and/or any other value configurable to adjust the A-V interval.

An exemplary method **230** of generating a difference value is depicted in FIG. **5**. The method **230** may include providing an identified A-V interval **232**. The identified A-V interval may be identified using the exemplary method **200** described herein with reference to FIG. **4**. The method **230** may further measure, or monitor, an intrinsic A-V conduction time for the patient **234**. Preferably, the patient may have the same activity level, heart rate, etc. as the patient had when the provided A-V interval was identified. The intrinsic A-V conduction time may be an average, mode, median, and/or any other statistical metric of a plurality of measured intrinsic A-V conduction times.

Using the intrinsic A-V conduction time **234** and the identified A-V interval **232**, the exemplary method **230** may generate, or calculate, a difference value **236**. In at least one embodiment, the difference value may be a difference ratio that is generated by dividing the intrinsic A-V conduction time by the identified A-V interval. For example, if the intrinsic A-V conduction time was 180 ms and the identified A-V interval was 120 ms, the difference value, or difference ratio, would be 1.5. In at least another embodiment, the difference value may be a difference time period that is generated by subtracting the identified A-V interval from the intrinsic A-V conduction time. For example, if the intrinsic A-V conduction time was 200 ms and the identified A-V interval was 150 ms, the difference value, or difference time period, would be 50 ms.

The difference value may then be used to periodically generate, or calculate, an A-V interval **238** for the delivery of cardiac pacing to the patient. Left univentricular pacing therapy as well as other cardiac pacing therapy may utilize more than one A-V interval: namely, a paced A-V (PAV) interval that is the interval from an atrial pace to the left ventricular pace and a sensed A-V interval (SAV) that is the interval from a sensed atrial event (e.g., intrinsic depolarization) to the left ventricular pace. It is to be understood that although the exemplary systems and methods described herein describe generating, or calculating, an A-V interval, it is to be understood that the term "A-V interval" is intended to capture all the A-V intervals used by cardiac pacing such as the PAV and SAV. As such, when the "A-V interval" is described as being generated, calculated, and/or adjusted, it is to be understood that more than one A-V interval may be generated, calculated, and/or adjusted. For example, in systems and methods that use PAV and SAV, each of the PAV and SAV may be generated, calculated, and/or adjusted when the "A-V interval" is generated, calculated, and/or adjusted as described herein.

An exemplary method **250** of periodically generating, or calculating, an A-V interval **238** for the delivery of cardiac pacing to the patient is shown in FIG. **6**. The exemplary method **250** may include pausing, or halting, ongoing pacing therapy **252** and measuring an intrinsic A-V conduction time **254**. Exemplary systems and methods for measuring, or sampling, intrinsic A-V conduction time may be described in U.S. Pat. No. 8,744,576 entitled "Sampling Intrinsic AV Conduction Time" and issued on Jun. 3, 2014, which is incorporated by reference herein in its entirety. As before, the intrinsic A-V conduction time may be an average, mode, median, and/or any other statistical metric of a plurality of measured intrinsic A-V conduction times. An A-V interval

may be calculated using the measuring intrinsic A-V conduction time and the difference value **256**.

For example, if a measured intrinsic conduction time of the patient were 200 ms and the difference value was a difference ratio of 1.5, the exemplary method **230** may divide the measured intrinsic conduction time by the difference ratio thereby generating an A-V interval of about 133 ms. Further, for example, if a measured intrinsic conduction time of the patient were 150 ms and the difference value was a difference ratio of 1.5, the exemplary method **230** may divide the measured intrinsic conduction time by the difference ratio thereby generating an A-V interval of about 100 ms.

Further, for example, if a measured intrinsic conduction time of the patient were 200 ms and the difference value was a difference time period of 50 ms, the exemplary method **230** may subtract the difference time period from the measured intrinsic conduction time thereby generating an A-V interval of about 150 ms. Further, for example, if a measured intrinsic conduction time of the patient were 180 ms and the difference value was a difference time period of 60 ms, the exemplary method **230** may subtract the difference time period from the measured intrinsic conduction time thereby generating an A-V interval of about 120 ms.

After the A-V interval has been generated, or calculated, **256**, the A-V interval may be evaluated to determine if the generated A-V interval should be used in the cardiac therapy **258**. For example, if the generated A-V interval is too long, the generated A-V interval may not provide effective and/or optimal pacing therapy to the patient. For example, the generated, or calculated, A-V interval may be compared to a threshold value, and if the A-V interval is greater than or equal to the threshold value, then the A-V interval may not be used for cardiac therapy and the A-V intervals may be set to nominal values (e.g., the SAV may be set to 100 ms and the PAV may be set to 150 ms). Likewise, if the A-V interval is less than the threshold value, then the A-V interval may be used for cardiac therapy. The threshold value may be greater than or equal to about 200 ms, greater than or equal to about 210 ms, greater than or equal to about 220 ms, greater than or equal to about 240 ms, greater than or equal to about 250 ms, greater than or equal to about 270 ms, greater than or equal to about 300 ms, etc. Further, the threshold value may be less than or equal to about 230 ms, less than or equal to about 260 ms, less than or equal to about 280 ms, less than or equal to about 310 ms, less than or equal to about 350 ms, less than or equal to about 370 ms, less than or equal to about 400 ms, etc.

[99] If the A-V interval has been evaluated **258** and is acceptable for the pacing therapy, the A-V interval may be set, or programmed, **260** and the pacing therapy may be resumed **262**.

The exemplary systems, methods, and graphical user interfaces described herein may be used with respect to the implantation and configuration of an implantable medical device (IMD) and/or one or more leads configured to be located proximate one or more portions of a patient's heart. For example, the exemplary systems, methods, and interfaces may be used in conjunction with an exemplary therapy system **10** described herein with reference to FIGS. **7-9**.

FIG. **7** is a conceptual diagram illustrating an exemplary therapy system **10** that may be used to deliver pacing therapy to a patient **14**. Patient **14** may, but not necessarily, be a human. The therapy system **10** may include an implantable medical device **16** (IMD), which may be coupled to leads **18**, **20**, **22**. The IMD **16** may be, e.g., an implantable pacemaker, cardioverter, and/or defibrillator, that delivers, or provides,

electrical signals to and/or measures, or monitors electrical signals from the heart 12 of the patient 14 via electrodes coupled to one or more of the leads 18, 20, 22.

The leads 18, 20, 22 extend into the heart 12 of the patient 14 to sense electrical activity of the heart 12 and/or to deliver electrical stimulation to the heart 12. In the example shown in FIG. 7, the right ventricular (RV) lead 18 extends through one or more veins (not shown), the superior vena cava (not shown), and the right atrium 26, and into the right ventricle 28. The left ventricular (LV) coronary sinus lead 20 extends through one or more veins, the vena cava, the right atrium 26, and into the coronary sinus 30 to a region adjacent to the free wall of the left ventricle 32 of the heart 12. The right atrial (RA) lead 22 extends through one or more veins and the vena cava, and into the right atrium 26 of the heart 12. Although the system 10 includes a RV lead 18, it is to be understood the exemplary systems and methods described herein may not utilize the electrodes located on the RV lead 18 for sensing and/or pacing. Further, it is to be understood that the system 10 is merely one example, and that the exemplary systems and methods described herein may utilize systems that do not include a RV lead 18 (e.g., for sensing and/or pacing).

The IMD 16 may sense, among other things, electrical signals attendant to the depolarization and repolarization of the heart 12 via electrodes coupled to at least one of the leads 18, 20, 22. In some examples, the IMD 16 provides pacing therapy (e.g., pacing pulses) to the heart 12 based on the electrical signals sensed within the heart 12. The IMD 16 may be operable to adjust one or more parameters associated with the pacing therapy such as, e.g., A-V delay and other various timings, pulse wide, amplitude, voltage, burst length, etc. Further, the IMD 16 may be operable to use various electrode configurations to deliver pacing therapy, which may be unipolar, bipolar, quadripolar, or further multipolar. For example, a multipolar lead may include several electrodes that can be used for delivering pacing therapy. Hence, a multipolar lead system may provide, or offer, multiple electrical vectors to pace from. A pacing vector may include at least one cathode, which may be at least one electrode located on at least one lead, and at least one anode, which may be at least one electrode located on at least one lead (e.g., the same lead, or a different lead) and/or on the casing, or can, of the IMD. While improvement in cardiac function as a result of the pacing therapy may primarily depend on the cathode, the electrical parameters like impedance, pacing threshold voltage, current drain, longevity, etc. may be more dependent on the pacing vector, which includes both the cathode and the anode. The IMD 16 may also provide defibrillation therapy and/or cardioversion therapy via electrodes located on at least one of the leads 18, 20, 22. Further, the IMD 16 may detect arrhythmia of the heart 12, such as fibrillation of the ventricles 28, 32, and deliver defibrillation therapy to the heart 12 in the form of electrical pulses. In some examples, IMD 16 may be programmed to deliver a progression of therapies, e.g., pulses with increasing energy levels, until a fibrillation of heart 12 is stopped.

FIGS. 8A-8B are conceptual diagrams illustrating the IMD 16 and the leads 18, 20, 22 of therapy system 10 of FIG. 7 in more detail. The leads 18, 20, 22 may be electrically coupled to a therapy delivery module (e.g., for delivery of pacing therapy), a sensing module (e.g., for sensing one or more signals from one or more electrodes), and/or any other modules of the IMD 16 via a connector block 34. In some examples, the proximal ends of the leads 18, 20, 22 may include electrical contacts that electrically

couple to respective electrical contacts within the connector block 34 of the IMD 16. In addition, in some examples, the leads 18, 20, 22 may be mechanically coupled to the connector block 34 with the aid of set screws, connection pins, or another suitable mechanical coupling mechanism.

Each of the leads 18, 20, 22 includes an elongated insulative lead body, which may carry a number of conductors (e.g., concentric coiled conductors, straight conductors, etc.) separated from one another by insulation (e.g., tubular insulative sheaths). In the illustrated example, bipolar electrodes 40, 42 are located proximate to a distal end of the lead 18. In addition, bipolar electrodes 44, 45, 46, 47 are located proximate to a distal end of the lead 20 and bipolar electrodes 48, 50 are located proximate to a distal end of the lead 22.

The electrodes 40, 44, 45, 46, 47, 48 may take the form of ring electrodes, and the electrodes 42, 50 may take the form of extendable helix tip electrodes mounted retractably within the insulative electrode heads 52, 54, 56, respectively. Each of the electrodes 40, 42, 44, 45, 46, 47, 48, 50 may be electrically coupled to a respective one of the conductors (e.g., coiled and/or straight) within the lead body of its associated lead 18, 20, 22, and thereby coupled to a respective one of the electrical contacts on the proximal end of the leads 18, 20, 22.

Additionally, electrodes 44, 45, 46 and 47 may have an electrode surface area of about 5.3 mm² to about 5.8 mm². Electrodes 44, 45, 46, and 47 may also be referred to as LV1, LV2, LV3, and LV4, respectively. The LV electrodes (i.e., left ventricle electrode 1 (LV1) 44, left ventricle electrode 2 (LV2) 45, left ventricle electrode 3 (LV3) 46, and left ventricle 4 (LV4) 47 etc.) on the lead 20 can be spaced apart at variable distances. For example, electrode 44 may be a distance of, e.g., about 21 millimeters (mm), away from electrode 45, electrodes 45 and 46 may be spaced a distance of, e.g., about 1.3 mm to about 1.5 mm, away from each other, and electrodes 46 and 47 may be spaced a distance of, e.g. 20 mm to about 21 mm, away from each other.

The electrodes 40, 42, 44, 45, 46, 47, 48, 50 may further be used to sense electrical signals (e.g., morphological waveforms within electrograms (EGM)) attendant to the depolarization and repolarization of the heart 12. The sensed electrical signals may be used to adjust one or more pacing parameters such as, e.g., A-V interval, V-V interval, etc. to provide optimal and/or effective cardiac functionality. The electrical signals are conducted to the IMD 16 via the respective leads 18, 20, 22. In some examples, the IMD 16 may also deliver pacing pulses via the electrodes 40, 42, 44, 45, 46, 47, 48, 50 to cause depolarization of cardiac tissue of the patient's heart 12. In some examples, as illustrated in FIG. 8A, the IMD 16 includes one or more housing electrodes, such as housing electrode 58, which may be formed integrally with an outer surface of a housing 60 (e.g., hermetically-sealed housing) of the IMD 16 or otherwise coupled to the housing 60. Any of the electrodes 40, 42, 44, 45, 46, 47, 48, 50 may be used for unipolar sensing or pacing in combination with the housing electrode 58. In other words, any of electrodes 40, 42, 44, 45, 46, 47, 48, 50, 58 may be used in combination to form a sensing vector, e.g., a sensing vector that may be used to evaluate and/or analyze the effectiveness of pacing therapy. It is to be understood by those skilled in the art that other electrodes can also be selected to define, or be used for, pacing and sensing vectors. Further, any of electrodes 40, 42, 44, 45, 46, 47, 48, 50, 58, when not being used to deliver pacing therapy, may be used to sense electrical activity during pacing therapy.

As described in further detail with reference to FIG. 8A, the housing 60 may enclose a therapy delivery module that may include a stimulation generator for generating cardiac pacing pulses and defibrillation or cardioversion shocks, as well as a sensing module for monitoring electrical signals of the patient's heart (e.g., the patient's heart rhythm). The leads 18, 20, 22 may also include elongated electrodes 62, 64, 66, respectively, which may take the form of a coil. The IMD 16 may deliver defibrillation shocks to the heart 12 via any combination of the elongated electrodes 62, 64, 66 and the housing electrode 58. The electrodes 58, 62, 64, 66 may also be used to deliver cardioversion pulses to the heart 12. Further, the electrodes 62, 64, 66 may be fabricated from any suitable electrically conductive material, such as, but not limited to, platinum, platinum alloy, and/or other materials known to be usable in implantable defibrillation electrodes. Since electrodes 62, 64, 66 are not generally configured to deliver pacing therapy, any of electrodes 62, 64, 66 may be used to sense electrical activity (e.g., for use in determining electrode effectiveness, for use in analyzing pacing therapy effectiveness, etc.) and may be used in combination with any of electrodes 40, 42, 44, 45, 46, 47, 48, 50, 58. In at least one embodiment, the RV elongated electrode 62 may be used to sense electrical activity of a patient's heart during the delivery of pacing therapy (e.g., in combination with the housing electrode 58, or defibrillation electrode-to-housing electrode vector).

The configuration of the exemplary therapy systems 10 illustrated in FIGS. 7-9 are merely a couple examples. In other examples, the therapy system may include epicardial leads and/or patch electrodes instead of or in addition to the transvenous leads 18, 20, 22 illustrated in FIG. 7. Additionally, in other examples, the therapy system 10 may be implanted in/around the cardiac space without transvenous leads (e.g., leadless/wireless pacing systems) or with leads implanted (e.g., implanted transvenously or using approaches) into the left chambers of the heart (in addition to or replacing the transvenous leads placed into the right chambers of the heart as illustrated in FIG. 7). An exemplary leadless system may be described in U.S. patent application Ser. No. 14/173,288 filed on Feb. 5, 2014 and entitled "Systems and Methods for Leadless Cardiac Resynchronization Therapy," which is incorporated herein by reference in its entirety. Further, in one or more embodiments, the IMD 16 need not be implanted within the patient 14. For example, the IMD 16 may deliver various cardiac therapies to the heart 12 via percutaneous leads that extend through the skin of the patient 14 to a variety of positions within or outside of the heart 12. In one or more embodiments, the system 10 may utilize wireless pacing (e.g., using energy transmission to the intracardiac pacing component(s) via ultrasound, inductive coupling, RF, etc.) and sensing cardiac activation using electrodes on the can/housing and/or on subcutaneous leads.

In other examples of therapy systems that provide electrical stimulation therapy to the heart 12, such therapy systems may include any suitable number of leads coupled to the IMD 16, and each of the leads may extend to any location within or proximate to the heart 12. For example, other examples of therapy systems may include less than or more than three transvenous leads. In at least one embodiment, the therapy system that provides pacing, or electrical stimulation, therapy to the heart 12 may only provide left univentricular pacing therapy with using, or including, sensing or pacing electrodes located in the left ventricle. In these left univentricular pacing systems, at least one pacing and/or sensing electrode may be located in the patient's left ven-

tricle and at least one pacing and/or sensing electrode may be located in one or both the right atrium and left atrium. Still further, other therapy systems may include a single lead that extends from the IMD 16 into the right atrium 26 or the right ventricle 28, or two leads that extend into a respective one of the right atrium 26 and the right ventricle 28.

FIG. 9A is a functional block diagram of one exemplary configuration of the IMD 16. As shown, the IMD 16 may include a control module 81, a therapy delivery module 84 (e.g., which may include a stimulation generator), a sensing module 86, and a power source 90.

The control module 81 may include a processor 80, memory 82, and a telemetry module 88. The memory 82 may include computer-readable instructions that, when executed, e.g., by the processor 80, cause the IMD 16 and/or the control module 81 to perform various functions attributed to the IMD 16 and/or the control module 81 described herein. Further, the memory 82 may include any volatile, non-volatile, magnetic, optical, and/or electrical media, such as a random access memory (RAM), read-only memory (ROM), non-volatile RAM (NVRAM), electrically-erasable programmable ROM (EEPROM), flash memory, and/or any other digital media. An exemplary capture management module may be the left ventricular capture management (LVCM) module described in U.S. Pat. No. 7,684,863 entitled "LV THRESHOLD MEASUREMENT AND CAPTURE MANAGEMENT" and issued Mar. 23, 2010, which is incorporated herein by reference in its entirety.

The processor 80 of the control module 81 may include any one or more of a microprocessor, a controller, a digital signal processor (DSP), an application specific integrated circuit (ASIC), a field-programmable gate array (FPGA), and/or equivalent discrete or integrated logic circuitry. In some examples, the processor 80 may include multiple components, such as any combination of one or more microprocessors, one or more controllers, one or more DSPs, one or more ASICs, and/or one or more FPGAs, as well as other discrete or integrated logic circuitry. The functions attributed to the processor 80 herein may be embodied as software, firmware, hardware, or any combination thereof.

The control module 81 may control the therapy delivery module 84 to deliver therapy (e.g., electrical stimulation therapy such as pacing) to the heart 12 according to a selected one or more therapy programs, which may be stored in the memory 82. More, specifically, the control module 81 (e.g., the processor 80) may control various parameters of the electrical stimulus delivered by the therapy delivery module 84 such as, e.g., A-V delays, V-V delays, pacing pulses with the amplitudes, pulse widths, frequency, or electrode polarities, etc., which may be specified by one or more selected therapy programs (e.g., A-V and/or V-V delay adjustment programs, pacing therapy programs, pacing recovery programs, capture management programs, etc.). As shown, the therapy delivery module 84 is electrically coupled to electrodes 40, 42, 44, 45, 46, 47, 48, 50, 58, 62, 64, 66, e.g., via conductors of the respective lead 18, 20, 22, or, in the case of housing electrode 58, via an electrical conductor disposed within housing 60 of IMD 16. Therapy delivery module 84 may be configured to generate and deliver electrical stimulation therapy such as pacing therapy to the heart 12 using one or more of the electrodes 40, 42, 44, 45, 46, 47, 48, 50, 58, 62, 64, 66.

For example, therapy delivery module 84 may deliver pacing stimulus (e.g., pacing pulses) via ring electrodes 40, 44, 45, 46, 47, 48 coupled to leads 18, 20, 22 and/or helical tip electrodes 42, 50 of leads 18, 22. Further, for example,

therapy delivery module **84** may deliver defibrillation shocks to heart **12** via at least two of electrodes **58**, **62**, **64**, **66**. In some examples, therapy delivery module **84** may be configured to deliver pacing, cardioversion, or defibrillation stimulation in the form of electrical pulses. In other examples, therapy delivery module **84** may be configured to deliver one or more of these types of stimulation in the form of other signals, such as sine waves, square waves, and/or other substantially continuous time signals.

The IMD **16** may further include a switch module **85** and the control module **81** (e.g., the processor **80**) may use the switch module **85** to select, e.g., via a data/address bus, which of the available electrodes are used to deliver therapy such as pacing pulses for pacing therapy, or which of the available electrodes are used for sensing. The switch module **85** may include a switch array, switch matrix, multiplexer, or any other type of switching device suitable to selectively couple the sensing module **86** and/or the therapy delivery module **84** to one or more selected electrodes. More specifically, the therapy delivery module **84** may include a plurality of pacing output circuits. Each pacing output circuit of the plurality of pacing output circuits may be selectively coupled, e.g., using the switch module **85**, to one or more of the electrodes **40**, **42**, **44**, **45**, **46**, **47**, **48**, **50**, **58**, **62**, **64**, **66** (e.g., a pair of electrodes for delivery of therapy using a bipolar or multipolar pacing vector). In other words, each electrode can be selectively coupled to one of the pacing output circuits of the therapy delivery module using the switching module **85**.

The sensing module **86** is coupled (e.g., electrically coupled) to sensing apparatus, which may include, among additional sensing apparatus, the electrodes **40**, **42**, **44**, **45**, **46**, **47**, **48**, **50**, **58**, **62**, **64**, **66** to monitor electrical activity of the heart **12**, e.g., electrocardiogram (ECG)/electrogram (EGM) signals, etc. The ECG/EGM signals may be used to measure or monitor activation times (e.g., ventricular activations times, etc.), heart rate (HR), heart rate variability (HRV), heart rate turbulence (HRT), deceleration/acceleration capacity, deceleration sequence incidence, T-wave alternans (TWA), P-wave to P-wave intervals (also referred to as the P-P intervals or A-A intervals), R-wave to R-wave intervals (also referred to as the R-R intervals or V-V intervals), P-wave to QRS complex intervals (also referred to as the P-R intervals, A-V intervals, or P-Q intervals), QRS-complex morphology, ST segment (i.e., the segment that connects the QRS complex and the T-wave), T-wave changes, QT intervals, electrical vectors, etc.

The switch module **85** may also be used with the sensing module **86** to select which of the available electrodes are used, or enabled, to, e.g., sense electrical activity of the patient's heart (e.g., one or more electrical vectors of the patient's heart using any combination of the electrodes **40**, **42**, **44**, **45**, **46**, **47**, **48**, **50**, **58**, **62**, **64**, **66**). Likewise, the switch module **85** may also be used with the sensing module **86** to select which of the available electrodes are not to be used (e.g., disabled) to, e.g., sense electrical activity of the patient's heart (e.g., one or more electrical vectors of the patient's heart using any combination of the electrodes **40**, **42**, **44**, **45**, **46**, **47**, **48**, **50**, **58**, **62**, **64**, **66**), etc. In some examples, the control module **81** may select the electrodes that function as sensing electrodes via the switch module within the sensing module **86**, e.g., by providing signals via a data/address bus.

In some examples, sensing module **86** includes a channel that includes an amplifier with a relatively wider pass band than the R-wave or P-wave amplifiers. Signals from the selected sensing electrodes may be provided to a multi-

plexer, and thereafter converted to multi-bit digital signals by an analog-to-digital converter for storage in memory **82**, e.g., as an electrogram (EGM). In some examples, the storage of such EGMs in memory **82** may be under the control of a direct memory access circuit.

In some examples, the control module **81** may operate as an interrupt driven device, and may be responsive to interrupts from pacer timing and control module, where the interrupts may correspond to the occurrences of sensed P-waves and R-waves and the generation of cardiac pacing pulses. Any necessary mathematical calculations may be performed by the processor **80** and any updating of the values or intervals controlled by the pacer timing and control module may take place following such interrupts. A portion of memory **82** may be configured as a plurality of recirculating buffers, capable of holding one or more series of measured intervals (e.g., intrinsic A-V conduction times), which may be analyzed by, e.g., the processor **80** in response to the occurrence of a pace or sense interrupt to determine whether the patient's heart **12** is presently exhibiting atrial or ventricular tachyarrhythmia.

The pacer timing and control module may include programmable counters which control the basic time intervals associated with DDD, VVI, DVI, VDD, AAI, DDI, DDDR, VVIR, DVIR, VDDR, AAIR, DDIR and other modes of single and dual chamber pacing. In the aforementioned pacing modes, "D" may indicate dual chamber, "V" may indicate a ventricle, "I" may indicate inhibited pacing (e.g., no pacing), and "A" may indicate an atrium. The first letter in the pacing mode may indicate the chamber that is paced, the second letter may indicate the chamber in which an electrical signal is sensed, and the third letter may indicate the chamber in which the response to sensing is provided.

The telemetry module **88** of the control module **81** may include any suitable hardware, firmware, software, or any combination thereof for communicating with another device, such as a programmer. For example, under the control of the processor **80**, the telemetry module **88** may receive downlink telemetry from and send uplink telemetry to a programmer with the aid of an antenna, which may be internal and/or external. The processor **80** may provide the data to be uplinked to a programmer and the control signals for the telemetry circuit within the telemetry module **88**, e.g., via an address/data bus. In some examples, the telemetry module **88** may provide received data to the processor **80** via a multiplexer.

The various components of the IMD **16** are further coupled to a power source **90**, which may include a rechargeable or non-rechargeable battery. A non-rechargeable battery may be selected to last for several years, while a rechargeable battery may be inductively charged from an external device, e.g., on a daily or weekly basis.

FIG. **9B** is another embodiment of a functional block diagram for IMD **16**. FIG. **9B** depicts bipolar RA lead **22**, bipolar RV lead **18**, and bipolar LV CS lead **20** without the LA CS pace/sense electrodes and coupled with an implantable pulse generator (IPG) circuit **31** having programmable modes and parameters of a bi-ventricular DDD/R type known in the pacing art. In turn, the sensor signal processing circuit **91** indirectly couples to the timing circuit **43** and via data and control bus to microcomputer circuitry **33**. The IPG circuit **31** is illustrated in a functional block diagram divided generally into a microcomputer circuit **33** and a pacing circuit **21**. The pacing circuit **21** includes the digital controller/timer circuit **43**, the output amplifiers circuit **51**, the sense amplifiers circuit **55**, the RF telemetry transceiver **41**,

the activity sensor circuit 35 as well as a number of other circuits and components described below.

Crystal oscillator circuit 89 provides the basic timing clock for the pacing circuit 21 while battery 29 provides power. Power-on-reset circuit 87 responds to initial connection of the circuit to the battery for defining an initial operating condition and similarly, resets the operative state of the device in response to detection of a low battery condition. Reference mode circuit 37 generates stable voltage reference and currents for the analog circuits within the pacing circuit 21. Analog-to-digital converter (ADC) and multiplexer circuit 39 digitize analog signals and voltage to provide, e.g., real time telemetry of cardiac signals from sense amplifiers 55 for uplink transmission via RF transmitter and receiver circuit 41. Voltage reference and bias circuit 37, ADC and multiplexer 39, power-on-reset circuit 87, and crystal oscillator circuit 89 may correspond to any of those used in exemplary implantable cardiac pacemakers.

If the IPG is programmed to a rate responsive mode, the signals output by one or more physiologic sensors are employed as a rate control parameter (RCP) to derive a physiologic escape interval. For example, the escape interval is adjusted proportionally to the patient's activity level developed in the patient activity sensor (PAS) circuit 35 in the depicted, exemplary IPG circuit 31. The patient activity sensor 27 is coupled to the IPG housing and may take the form of a piezoelectric crystal transducer. An output signal of the patient activity sensor 27 may be processed and used as a RCP. Sensor 27 generates electrical signals in response to sensed physical activity that are processed by activity circuit 35 and provided to digital controller/timer circuit 43. Activity circuit 35 and associated sensor 27 may correspond to the circuitry disclosed in U.S. Pat. No. 5,052,388 entitled "METHOD AND APPARATUS FOR IMPLEMENTING ACTIVITY SENSING IN A PULSE GENERATOR" and issued on Oct. 1, 1991 and U.S. Pat. No. 4,428,378 entitled "RATE ADAPTIVE PACER" and issued on Jan. 31, 1984, each of which is incorporated herein by reference in its entirety. Similarly, the exemplary systems, apparatus, and methods described herein may be practiced in conjunction with alternate types of sensors such as oxygenation sensors, pressure sensors, pH sensors, and respiration sensors for use in providing rate responsive pacing capabilities. Alternately, QT time may be used as a rate indicating parameter, in which case no extra sensor is required. Similarly, the exemplary embodiments described herein may also be practiced in non-rate responsive pacemakers.

Data transmission to and from the external programmer is accomplished by way of the telemetry antenna 57 and an associated RF transceiver 41, which serves both to demodulate received downlink telemetry and to transmit uplink telemetry. Uplink telemetry capabilities may include the ability to transmit stored digital information, e.g., operating modes and parameters, EGM histograms, and other events, as well as real time EGMs of atrial and/or ventricular electrical activity and marker channel pulses indicating the occurrence of sensed and paced depolarizations in the atrium and ventricle.

Microcomputer 33 contains a microprocessor 80 and associated system clock and on-processor RAM and ROM chips 82A and 82B, respectively. In addition, microcomputer circuit 33 includes a separate RAM/ROM chip 82C to provide additional memory capacity. Microprocessor 80 normally operates in a reduced power consumption mode and is interrupt driven. Microprocessor 80 is awakened in response to defined interrupt events, which may include A-TRIG, RV-TRIG, LV-TRIG signals generated by timers in

digital timer/controller circuit 43 and A-EVENT, RV-EVENT, and LV-EVENT signals generated by sense amplifiers circuit 55, among others. The specific values of the intervals and delays timed out by digital controller/timer circuit 43 are controlled by the microcomputer circuit 33 by way of data and control bus from programmed-in parameter values and operating modes. In addition, if programmed to operate as a rate responsive pacemaker, a timed interrupt, e.g., every cycle or every two seconds, may be provided in order to allow the microprocessor to analyze the activity sensor data and update the basic A-A, V-A, or V-V escape interval, as applicable. In addition, the microprocessor 80 may also serve to define variable, operative A-V delay intervals and/or V-V intervals, and the energy delivered to the ventricles and/or atria.

In one embodiment, microprocessor 80 is a custom microprocessor adapted to fetch and execute instructions stored in RAM/ROM unit 82 in a conventional manner. It is contemplated, however, that other implementations may be suitable to practice the present invention. For example, an off-the-shelf, commercially available microprocessor or microcontroller, or custom application-specific, hardwired logic, or state-machine type circuit may perform the functions of microprocessor 80.

Digital controller/timer circuit 43 operates under the general control of the microcomputer 33 to control timing and other functions within the pacing circuit 321 and includes a set of timing and associated logic circuits of which certain ones pertinent to the present invention are depicted. The depicted timing circuits include URI/LRI timers 83A, V-V delay timer 83B, intrinsic interval timers 83C for timing elapsed V-EVENT to V-EVENT intervals or V-EVENT to A-EVENT intervals or the V-V conduction interval, escape interval timers 83D for timing A-A, V-A, and/or V-V pacing escape intervals, an A-V delay interval timer 83E for timing the A-LVp delay (or A-RVp delay) from a preceding A-EVENT or A-TRIG, a post-ventricular timer 83F for timing post-ventricular time periods, and a date/time clock 83G.

The A-V delay interval timer 83E is loaded with an appropriate delay interval for one ventricular chamber (e.g., either an A-RVp delay or an A-LVp delay) to time-out starting from a preceding A-PACE or A-EVENT. The interval timer 83E triggers pacing stimulus delivery, and can be based on one or more prior cardiac cycles (or from a data set empirically derived for a given patient).

The post-event timer 83F times out the post-ventricular time period following an RV-EVENT or LV-EVENT or a RV-TRIG or LV-TRIG and post-atrial time periods following an A-EVENT or A-TRIG. The durations of the post-event time periods may also be selected as programmable parameters stored in the microcomputer 33. The post-ventricular time periods include the PVARP, a post-atrial ventricular blanking period (PAVBP), a ventricular blanking period (VBP), a post-ventricular atrial blanking period (PVARP) and a ventricular refractory period (VRP) although other periods can be suitably defined depending, at least in part, on the operative circuitry employed in the pacing engine. The post-atrial time periods include an atrial refractory period (ARP) during which an A-EVENT is ignored for the purpose of resetting any A-V delay, and an atrial blanking period (ABP) during which atrial sensing is disabled. It should be noted that the starting of the post-atrial time periods and the A-V delays can be commenced substantially simultaneously with the start or end of each A-EVENT or A-TRIG or, in the latter case, upon the end of the A-PACE which may follow the A-TRIG. Similarly, the starting of the

post-ventricular time periods and the V-A escape interval can be commenced substantially simultaneously with the start or end of the V-EVENT or V-TRIG or, in the latter case, upon the end of the V-PACE which may follow the V-TRIG. The microprocessor **80** also optionally calculates A-V delays, V-V delays, post-ventricular time periods, and post-atrial time periods that vary with the sensor based escape interval established in response to the RCP(s), intrinsic A-V conduction times, intrinsic heart rate, and/or any other parameter or metric.

The output amplifiers circuit **51** contains a RA pace pulse generator (and a LA pace pulse generator if LA pacing is provided), a RV pace pulse generator, a LV pace pulse generator, and/or any other pulse generator configured to provide atrial and ventricular pacing. In order to trigger generation of an RV-PACE or LV-PACE pulse, digital controller/timer circuit **43** generates the RV-TRIG signal at the time-out of the A-RV_p delay (in the case of RV pre-excitation) or the LV-TRIG at the time-out of the A-LV_p delay (in the case of LV pre-excitation) provided by AV delay interval timer **83E** (or the V-V delay timer **83B**). Similarly, digital controller/timer circuit **43** generates an RA-TRIG signal that triggers output of an RA-PACE pulse (or an LA-TRIG signal that triggers output of an LA-PACE pulse, if provided) at the end of the V-A escape interval timed by escape interval timers **83D**.

The output amplifiers circuit **51** includes switching circuits for coupling selected pace electrode pairs from among the lead conductors and the IND-CAN electrode **20** to the RA pace pulse generator (and LA pace pulse generator if provided), RV pace pulse generator and LV pace pulse generator. Pace/sense electrode pair selection and control circuit **53** selects lead conductors and associated pace electrode pairs to be coupled with the atrial and ventricular output amplifiers within output amplifiers circuit **51** for accomplishing RA, LA, RV and LV pacing.

The sense amplifiers circuit **55** contains sense amplifiers for atrial and ventricular pacing and sensing. High impedance P-wave and R-wave sense amplifiers may be used to amplify a voltage difference signal that is generated across the sense electrode pairs by the passage of cardiac depolarization wavefronts. The high impedance sense amplifiers use high gain to amplify the low amplitude signals and rely on pass band filters, time domain filtering and amplitude threshold comparison to discriminate a P-wave or R-wave from background electrical noise. Digital controller/timer circuit **43** controls sensitivity settings of the atrial and ventricular sense amplifiers **55**.

The sense amplifiers may be uncoupled from the sense electrodes during the blanking periods before, during, and after delivery of a pace pulse to any of the pace electrodes of the pacing system to avoid saturation of the sense amplifiers. The sense amplifiers circuit **55** includes blanking circuits for uncoupling the selected pairs of the lead conductors and the IND-CAN electrode **20** from the inputs of the RA sense amplifier (and LA sense amplifier if provided), RV sense amplifier and LV sense amplifier during the ABP, PVABP and VBP. The sense amplifiers circuit **55** also includes switching circuits for coupling selected sense electrode lead conductors and the IND-CAN electrode **20** to the RA sense amplifier (and LA sense amplifier if provided), RV sense amplifier and LV sense amplifier. Again, sense electrode selection and control circuit **53** selects conductors and associated sense electrode pairs to be coupled with the atrial and ventricular sense amplifiers within the output amplifiers

circuit **51** and sense amplifiers circuit **55** for accomplishing RA, LA, RV, and LV sensing along desired unipolar and bipolar sensing vectors.

Right atrial depolarizations or P-waves in the RA-SENSE signal that are sensed by the RA sense amplifier result in a RA-EVENT signal that is communicated to the digital controller/timer circuit **43**. Similarly, left atrial depolarizations or P-waves in the LA-SENSE signal that are sensed by the LA sense amplifier, if provided, result in a LA-EVENT signal that is communicated to the digital controller/timer circuit **43**. Ventricular depolarizations or R-waves in the RV-SENSE signal are sensed by a ventricular sense amplifier result in an RV-EVENT signal that is communicated to the digital controller/timer circuit **43**. Similarly, ventricular depolarizations or R-waves in the LV-SENSE signal are sensed by a ventricular sense amplifier result in an LV-EVENT signal that is communicated to the digital controller/timer circuit **43**. The RV-EVENT, LV-EVENT, and RA-EVENT, LA-SENSE signals may be refractory or non-refractory, and can inadvertently be triggered by electrical noise signals or aberrantly conducted depolarization waves rather than true R-waves or P-waves.

The techniques described in this disclosure, including those attributed to the IMD **16**, the computing apparatus **140**, and/or various constituent components, may be implemented, at least in part, in hardware, software, firmware, or any combination thereof. For example, various aspects of the techniques may be implemented within one or more processors, including one or more microprocessors, DSPs, ASICs, FPGAs, or any other equivalent integrated or discrete logic circuitry, as well as any combinations of such components, embodied in programmers, such as physician or patient programmers, stimulators, image processing devices, or other devices. The term "module," "processor," or "processing circuitry" may generally refer to any of the foregoing logic circuitry, alone or in combination with other logic circuitry, or any other equivalent circuitry.

Such hardware, software, and/or firmware may be implemented within the same device or within separate devices to support the various operations and functions described in this disclosure. In addition, any of the described units, modules, or components may be implemented together or separately as discrete but interoperable logic devices. Depiction of different features as modules or units is intended to highlight different functional aspects and does not necessarily imply that such modules or units must be realized by separate hardware or software components. Rather, functionality associated with one or more modules or units may be performed by separate hardware or software components, or integrated within common or separate hardware or software components.

When implemented in software, the functionality ascribed to the systems, devices and techniques described in this disclosure may be embodied as instructions on a computer-readable medium such as RAM, ROM, NVRAM, EEPROM, FLASH memory, magnetic data storage media, optical data storage media, or the like. The instructions may be executed by one or more processors to support one or more aspects of the functionality described in this disclosure.

This disclosure has been provided with reference to illustrative embodiments and is not meant to be construed in a limiting sense. As described previously, one skilled in the art will recognize that other various illustrative applications may use the techniques as described herein to take advantage of the beneficial characteristics of the apparatus and methods described herein. Various modifications of the

illustrative embodiments, as well as additional embodiments of the disclosure, will be apparent upon reference to this description.

What is claimed:

1. A system for use in cardiac therapy comprising: electrode apparatus comprising a plurality of external electrodes configured to be located proximate tissue of a patient; and computing apparatus coupled to the electrode apparatus and configured to:
 - initiate delivery of left ventricular pacing therapy at a plurality of different A-V intervals, wherein the left ventricular pacing therapy is delivered using at least one pacing electrode configured to pace the patient's left ventricle and without any sensing electrodes located in the patient's right ventricle,
 - monitor electrical activity using the plurality of external electrodes during the delivery of left ventricular pacing therapy,
 - generate electrical heterogeneity information representative of at least one of mechanical cardiac functionality and electrical cardiac functionality for each of the plurality of different A-V intervals based on the monitored electrical activity, and
 - identify an A-V interval from the plurality of different A-V intervals based on the electrical heterogeneity information.
2. The system of claim 1, wherein the plurality of different A-V intervals comprises a plurality of paced A-V intervals (PAV) and a plurality of sensed A-V intervals (SAV).
3. The system of claim 1, wherein the electrical heterogeneity information comprises at least one metric of global or local surrogate electrical heterogeneity.
4. The system of claim 1, wherein the electrical heterogeneity information comprises a global standard deviation of surrogate electrical activation times monitored by the plurality of external electrodes, wherein identifying a A-V interval from the plurality of different A-V intervals based on the electrical heterogeneity information comprises identifying the A-V interval from the plurality of different A-V intervals that generated the lowest global standard deviation of surrogate electrical activation times.
5. The system of claim 1, wherein the electrical heterogeneity information comprises a left standard deviation of surrogate electrical activation times monitored by the two or more left external electrodes, wherein identifying a A-V interval from the plurality of different A-V intervals based on the electrical heterogeneity information comprises identifying the A-V interval from the plurality of different A-V intervals that generated the lowest left standard deviation of surrogate electrical activation times.
6. The system of claim 1, wherein the electrical heterogeneity information comprises a left average of surrogate electrical activation times monitored by the two or more left external electrodes, wherein identifying a A-V interval from the plurality of different A-V intervals based on the electrical heterogeneity information comprises identifying the A-V interval from the plurality of different A-V intervals that generated the lowest left average of surrogate electrical activation times.
7. The system of claim 1, wherein identifying an A-V interval from the plurality of different A-V intervals based on the electrical heterogeneity information further comprises identifying an A-V interval from the plurality of different A-V intervals based on a QRS duration metric for each A-V interval of the plurality of different A-V intervals.

8. The system of claim 1, wherein initiating delivery of left ventricular pacing therapy at a plurality of different A-V intervals comprises:

- setting the A-V interval to an initial A-V interval value;
- delivering left ventricular pacing therapy at the A-V interval; and
- periodically increasing the A-V interval by a selected increment until an intrinsic A-V conduction is sensed.

9. The system of claim 1, wherein the plurality of external electrodes comprises surface electrodes positioned in an array configured to be located proximate the skin of the torso of the patient.

10. The system of claim 1, wherein the system further comprises display apparatus, wherein the display apparatus comprises a graphical user interface configured to present information for use in evaluating and adjusting left ventricular cardiac therapy delivered to a patient,

- wherein the computing apparatus is further configured to display at least the identified A-V interval on the graphical user interface.

11. A system for use in cardiac therapy comprising:

electrode apparatus comprising a plurality of external electrodes configured to be located proximate tissue of a patient; and

computing apparatus coupled to the electrode apparatus and configured to:

- initiate delivery of left ventricular pacing therapy at a plurality of different A-V intervals,
- monitor electrical activity using the plurality of external electrodes during the delivery of left ventricular pacing therapy,
- generate electrical heterogeneity information representative of at least one of mechanical cardiac functionality and electrical cardiac functionality for each of the plurality of different A-V intervals based on the monitored electrical activity,
- identify an A-V interval from the plurality of different A-V intervals based on the electrical heterogeneity information, and
- determine a difference value for use in adjusting the A-V interval during left ventricular pacing therapy based on the identified A-V interval and an intrinsic A-V conduction time.

12. The system of claim 11, wherein the pacing therapy is delivered using at least one pacing electrode configured to pace the patient's left ventricle and without any sensing electrodes located in the patient's right ventricle.

13. The system of claim 11, wherein the difference value is configured to be used periodically during the delivery of left ventricular pacing therapy such that, periodically, a patient's intrinsic A-V conduction time is measured and the difference value is applied to the measured intrinsic A-V conduction time to provide the A-V interval used in the delivery of pacing therapy.

14. The system of claim 13, wherein, if the provided A-V interval is greater than or equal to a threshold value, the provided A-V interval is not used in the delivery of pacing therapy.

15. A method for use in cardiac therapy comprising: initiating delivery of left ventricular pacing therapy at a plurality of different A-V intervals, wherein the left ventricular pacing therapy is delivered using at least one pacing electrode configured to pace the patient's left ventricle and without any sensing electrodes located in the patient's right ventricle;

monitoring electrical activity using a plurality of external electrodes during the delivery of left ventricular pacing therapy;

generating electrical heterogeneity information representative of at least one of mechanical cardiac functionality and electrical cardiac functionality for each of the plurality of different A-V intervals based on the monitored electrical activity; and

identifying an A-V interval from the plurality of different A-V intervals based on the electrical heterogeneity information.

16. The method of claim 15, wherein the plurality of different A-V intervals comprises a plurality of paced A-V intervals (PAV) and a plurality of sensed A-V intervals (SAV).

17. The method of claim 15, wherein the electrical heterogeneity information comprises at least one metric of global or local surrogate electrical heterogeneity.

18. The method of claim 15, wherein the electrical heterogeneity information comprises a global standard deviation of surrogate electrical activation times monitored by the plurality of external electrodes, wherein identifying a A-V interval from the plurality of different A-V intervals based on the electrical heterogeneity information comprises identifying the A-V interval from the plurality of different A-V intervals that generated the lowest global standard deviation of surrogate electrical activation times.

19. The method of claim 15, wherein the electrical heterogeneity information comprises a left standard deviation of surrogate electrical activation times monitored by the two or more left external electrodes, wherein identifying a A-V interval from the plurality of different A-V intervals based on the electrical heterogeneity information comprises identifying the A-V interval from the plurality of different A-V intervals that generated the lowest left standard deviation of surrogate electrical activation times.

20. The method of claim 15, wherein the electrical heterogeneity information comprises a left average of surrogate electrical activation times monitored by the two or more left external electrodes, wherein identifying a A-V interval from the plurality of different A-V intervals based on the electrical heterogeneity information comprises identifying the A-V interval from the plurality of different A-V intervals that generated the lowest left average of surrogate electrical activation times.

21. The method of claim 15, wherein identifying an A-V interval from the plurality of different A-V intervals based on the electrical heterogeneity information further comprises identifying an A-V interval from the plurality of different A-V intervals based on a QRS duration metric for each A-V interval of the plurality of different A-V intervals.

22. The method of claim 15, wherein initiating delivery of left ventricular pacing therapy at a plurality of different A-V intervals comprises:

setting the A-V interval to an initial A-V interval value; delivering left ventricular pacing therapy at the A-V interval; and

periodically increasing the A-V interval by a selected increment until an intrinsic A-V conduction is sensed.

23. The method of claim 15, wherein the plurality of external electrodes comprises surface electrodes positioned in an array configured to be located proximate the skin of the torso of the patient.

24. The method of claim 15, wherein the method further comprises displaying display at least the identified A-V interval on a graphical user interface configured to present information for use in evaluating and adjusting left ventricular cardiac therapy delivered to a patient.

25. A method for use in cardiac therapy comprising:

initiating delivery of left ventricular pacing therapy at a plurality of different A-V intervals;

monitoring electrical activity using a plurality of external electrodes during the delivery of left ventricular pacing therapy;

generating electrical heterogeneity information representative of at least one of mechanical cardiac functionality and electrical cardiac functionality for each of the plurality of different A-V intervals based on the monitored electrical activity;

identifying an A-V interval from the plurality of different A-V intervals based on the electrical heterogeneity information; and

determining a difference value for use in adjusting the A-V interval during left ventricular pacing therapy based on the identified A-V interval and an intrinsic A-V conduction time.

26. The method of claim 25, wherein the pacing therapy is delivered using at least one pacing electrode configured to pace the patient's left ventricle and without any sensing electrodes located in the patient's right ventricle.

27. The method of claim 25, wherein the difference value is configured to be used periodically during the delivery of left ventricular pacing therapy such that, periodically, a patient's intrinsic A-V conduction time is measured and the difference value is applied to the measured intrinsic A-V conduction time to provide the A-V interval used in the delivery of pacing therapy.

28. The method of claim 27, wherein, if the provided A-V interval is greater than or equal to a threshold value, the provided A-V interval is not used in the delivery of pacing therapy.

* * * * *

专利名称(译)	用于配置房室间隔的系统和方法		
公开(公告)号	US9586050	公开(公告)日	2017-03-07
申请号	US14/703365	申请日	2015-05-04
[标]申请(专利权)人(译)	美敦力公司		
申请(专利权)人(译)	美敦力公司, INC.		
当前申请(专利权)人(译)	美敦力公司, INC.		
[标]发明人	GHOSH SUBHAM GILLBERG JEFFREY		
发明人	GHOSH, SUBHAM GILLBERG, JEFFREY		
IPC分类号	A61N1/00 A61N1/368 A61N1/365 A61N1/372 A61B5/0408 A61B5/00		
CPC分类号	A61N1/3684 A61B5/04085 A61B5/6823 A61N1/365 A61N1/3682 A61N1/36514 A61N1/37247 A61N1/37264 A61N1/36842		
优先权	62/037700 2014-08-15 US		
其他公开文献	US20160045738A1		
外部链接	Espacenet USPTO		

摘要(译)

本文描述了用于帮助用户识别和/或优化用于心脏治疗的房室 (A-V) 间隔的系统和方法。该系统和方法可以使用外部电极设备监测患者的电活动，以提供多个不同A-V间隔的电异质性信息，并且可以基于电异质性信息识别A-V间期。

