



US 20190082994A1

(19) **United States**

(12) **Patent Application Publication**
GUGER et al.

(10) **Pub. No.: US 2019/0082994 A1**
(43) **Pub. Date: Mar. 21, 2019**

(54) **ELECTRODE CAP**

A61B 5/0488 (2006.01)

(71) Applicants: **CHRISTOPH GUGER, PIBERBACH**
(AT); **GUENTER EDLINGER, GRAZ**
(AT)

A61B 5/05 (2006.01)

A61B 5/00 (2006.01)

(72) Inventors: **CHRISTOPH GUGER, PIBERBACH**
(AT); **GUENTER EDLINGER, GRAZ**
(AT)

(52) **U.S. Cl.**
CPC *A61B 5/04085* (2013.01); *A61B 5/0428*
(2013.01); *A61B 5/6803* (2013.01); *A61B 5/05*
(2013.01); *A61B 5/6814* (2013.01); *A61B*
5/0488 (2013.01)

(21) Appl. No.: **16/083,579**

(22) PCT Filed: **Mar. 6, 2017**

(57) **ABSTRACT**

(86) PCT No.: **PCT/AT2017/060056**

§ 371 (c)(1),

(2) Date: **Sep. 10, 2018**

(30) **Foreign Application Priority Data**

Mar. 9, 2016 (AT) A50198/2016

Publication Classification

(51) **Int. Cl.**

A61B 5/0408 (2006.01)

A61B 5/0428 (2006.01)

An electrode cap contains at least one electrode array and is to be applied to a subject's head. The electrode array contains an insulating layer, two electrodes disposed opposite one another on the insulating layer, namely a first measurement electrode facing toward the subject's head and a reference electrode facing away from the subject's head. A conductive body abuts the reference electrode and is in electrical contact therewith, and is arranged on the side of the reference electrode that faces away from the subject's head. The individual conductive bodies of all the electrode arrays are electrically connected to each other.

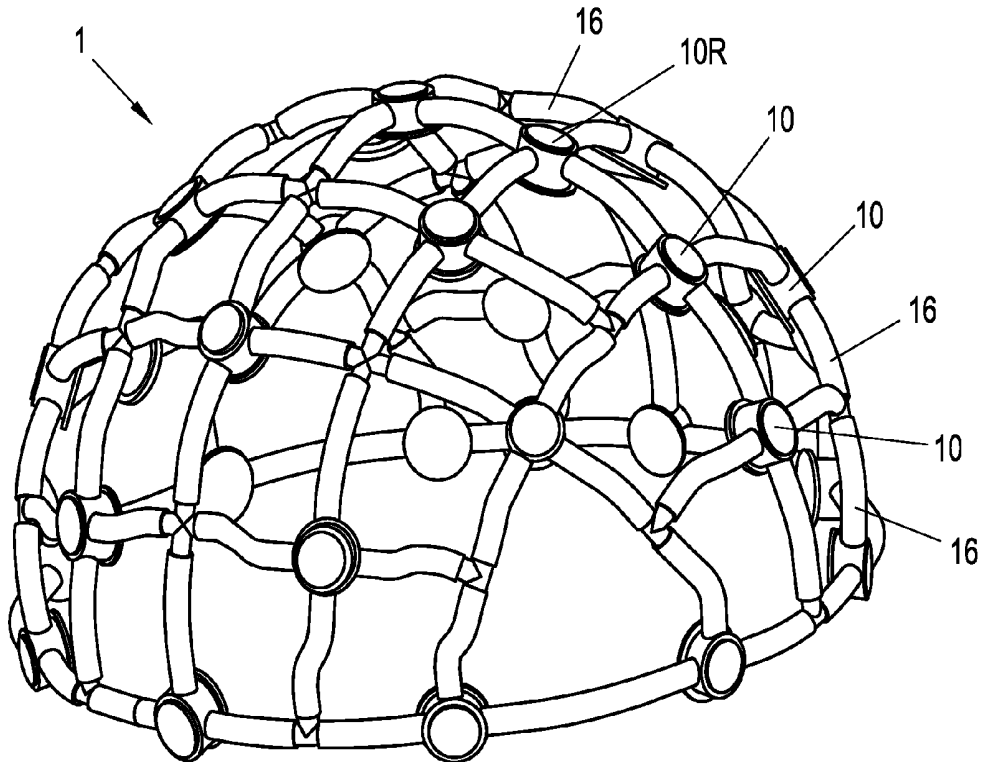

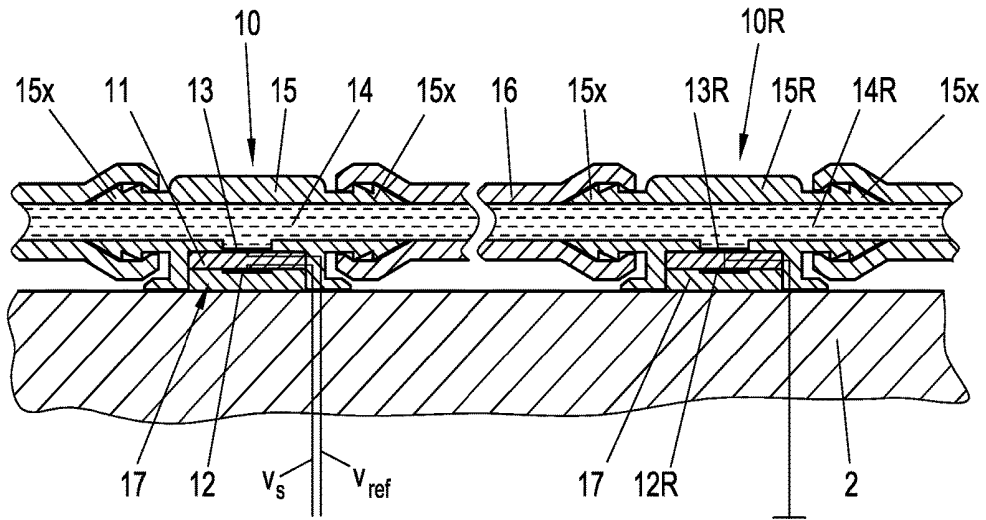

Fig. 1

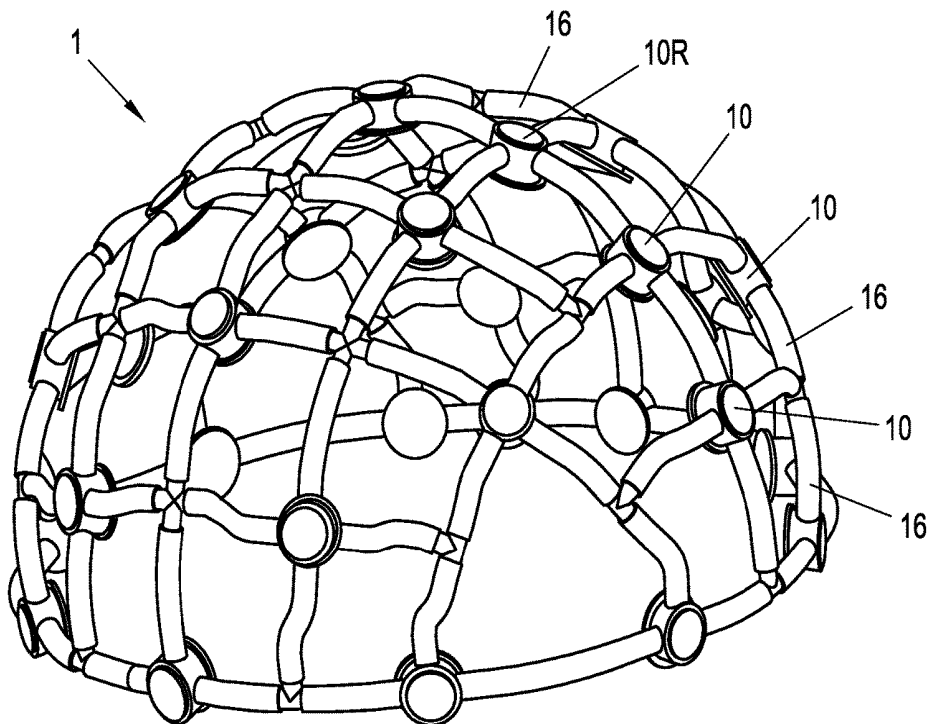

Fig. 2

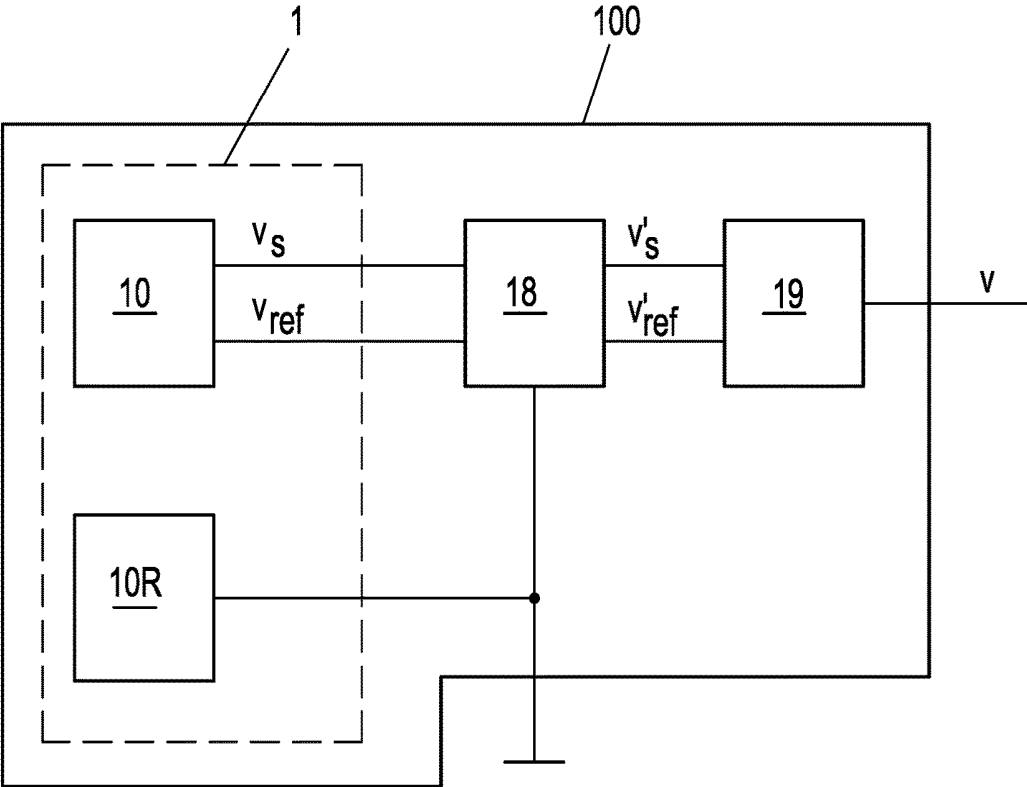

Fig. 3

ELECTRODE CAP

[0001] The invention relates to an electrode cap comprising at least one electrode array to be applied to the subject's head according to claim 1.

[0002] The invention further relates to an EEG measuring arrangement according to claim 8.

[0003] A large number of different electrode caps to be applied to a subject's head are known from the prior art. In general, such electrode caps have the drawback that measurement signals at individual electrodes are subject to different disturbances.

[0004] The objective of this invention is to provide an electrode cap that is largely unaffected by interference emanating from electromagnetic fields or structures outside the electrode cap. The present invention solves this problem with an electrode cap of the above-mentioned type, having the features of claim 1.

[0005] It is contemplated that each of the electrode arrays comprises:

[0006] an insulating layer,

[0007] two electrodes opposite one another on the insulating layer, namely a first measurement electrode facing toward the subject's head and a reference electrode facing away from the subject's head, and

[0008] a conductive body that abuts the reference electrode and is in electrical contact therewith, arranged on the side of the reference electrode facing away from the subject's head, and

[0009] wherein the individual conductive bodies of all electrode arrays are electrically connected to each other.

[0010] It is particularly advantageous that electromagnetic influences from outside the electrode cap via the continuous conductive body affect the measurement signals of all electrodes equally, so that signals that are completely independent of the external electromagnetic influences or interference may be obtained by simple compensation.

[0011] Particularly preferably, for connecting a measuring arrangement to a common system ground, it may be contemplated that a reference electrode array is provided, for applying to the subject's head, that has at least one electrode facing toward the subject's head and is electrically connected to the individual conductive bodies of the electrode arrays.

[0012] In a particularly structurally simple embodiment of the invention, it is contemplated that the conductive body of the reference electrode array is electrically conductively connected to the conductive bodies of all the electrode arrays.

[0013] A simple possibility for creating a continuous conductive body contemplates that the conductive body of the or each electrode array, optionally of the reference electrode array, is formed by a fluid that is in electrical contact with the reference electrode and/or the second electrode, in particular a saline solution, and/or that the conductive body has a specific conductivity between 2 mS/cm and 40 mS/cm.

[0014] In this case, for the modular design of individual electrode arrays it may be contemplated that the individual electrode arrays and optionally the reference electrode array respectively have a container bounded by the reference electrode and/or the second electrode, in which the fluid is contained, and that the individual containers are connected and thus form vessels that communicate with one another, in particular via hose connections.

[0015] To provide a particularly simple modular adaptation of the electrode cap to different head shapes, the electrode cap may be formed as a tubular network of electrode arrays connected to one another via hose connections, wherein the individual containers of the electrode arrays have connectors for connecting, in particular reversibly, with the hose connections.

[0016] A particularly advantageous contacting of the subject's head to the electrode cap contemplates that at least one or each of the electrode arrays, and optionally the reference electrode array, has a recess for receiving a conductive gel, the recess being bounded by the measurement electrode or the first electrode and being open toward the subject's head.

[0017] An advantageous measuring arrangement comprises an electrode cap according to the invention and a measuring device for determining the voltages applied to the electrodes. Particularly advantageously, for further processing of the signals, a processing unit may be furnished that relates those electrical signals that are respectively applied to the measurement electrode and the reference electrode of the same electrode array to each other, and in particular subtracts the two signals from each other, thus creating a cleaned signal for the electrode array.

[0018] To provide a reference potential, particularly simply, the at least one electrode or the two electrodes of the reference electrode array may be connected to a reference potential of the measuring device.

[0019] A preferred embodiment of the invention is illustrated in greater detail with reference to the following drawings.

[0020] FIG. 1 shows schematically the structure of two electrode arrays having a common conductive body.

[0021] FIG. 2 shows the structure of an electrode cap in its entirety.

[0022] FIG. 3 shows an EEG measuring arrangement corresponding to an exemplary embodiment of the invention.

[0023] In FIG. 1, the subject's head 2 is shown, to which are connected an electrode array 10 and a reference electrode array 10R. The first electrode array 10 comprises an insulating layer 11 and two electrodes 12, 13 opposite one another on the insulating layer 11. The first of the two opposing electrodes 12 is located on the side facing toward the subject's head 2. The electrode array 10 has a recess 17 for receiving conductive gel, which is bounded by the first electrode 10 and is open toward the subject's head 2. Conductive gel may be inserted into this recess 17 so that the first electrode 12 is in electrical contact with the subject's head 2.

[0024] Furthermore, each of the electrode arrays 10 respectively has a reference electrode 13 arranged on the side of the insulating layer 11 opposite the measurement electrode 12. The reference electrode 13 is in electric contact with a conductive body 14 that abuts the reference electrode 13. The conductive body 14 is arranged on the side of the reference electrode 13 that faces away from the subject's head 2. The electrode cap 1 comprises a plurality of electrode arrays 10 each having a separate insulating layer 11 and respectively separate electrodes 12, 13 lying opposite one another. For all or part of the electrode arrays 10, a common conductive body 14 is respectively available. Alternatively it may also be contemplated that for each of the electrode arrays 10 there is respectively a separate conduc-

tive body 14 and all of the conductive bodies 14 of the individual electrode arrays 10 are electrically connected to each other.

[0025] In the embodiment of the invention shown in FIG. 1, a reference electrode array 10R for applying to the subject's head 2 is furnished, in addition to the electrode array 10. The reference electrode array 10R is substantially structured like the electrode array 10, and more particularly has an electrode 12R facing toward the subject's head 2. Overall, however, it is only necessary that a single electrode 12R be furnished on the side facing toward the subject's head 2, which is conductively connected in whatever way to the individual conductive bodies of the reference electrode array 10R. Such a reference electrode array 10R may be implemented particularly advantageously if it is designed in the same way as the individual electrode arrays 10, the reference electrode array 10R comprising:

[0026] an insulating layer 11,

[0027] two electrodes 12R, 13R opposite one another on the insulating layer 11, namely a first electrode 12R facing toward the subject's head 2 and a second electrode 13R facing away from the subject's head 2, wherein the first and second electrode 13R are electrically connected together,

[0028] a conductive body 14R abutting the second electrode 13R and in electrical contact therewith, which is arranged on the side of the second electrode 13R that faces away from the subject's head 2.

[0029] The conductive body 14R of the reference electrode array 10R is electrically connected to the conductive bodies 14 of the electrode arrays 10.

[0030] As also initially described with regard to the electrode arrays 10, there is preferably also a possibility for the reference electrode array 10R to be furnished with a recess 17, for receiving conductive gel, bounded by the first electrode 12R and open toward the subject's head 2.

[0031] FIGS. 1 and 2 show a particularly preferred embodiment of the invention in greater detail, providing a common conductive body 14 formed by a fluid, in particular a saline solution, that is in contact with the individual reference electrodes 13 and optionally the second electrode 13R. The conductive body 14 in this preferred embodiment of the invention has a specific conductivity between 2 mS/cm and 40 mS/cm.

[0032] As shown in FIG. 1, each individual electrode array 10 and the reference electrode array 10R respectively have a container 15, 15R bounded by the reference electrode 13 and the second electrode 13R. The fluid that forms the conductive body 14 is contained in this container. The individual containers 15, 15R of the electrode array 10 or reference electrode array 10R are connected to one another via hose connections 16, and thus form a communicating vessel. As shown in FIG. 2, each of the electrode arrays 10 and reference electrode arrays 10R respectively has a number of connectors 15X for hose connections 16. The individual electrode arrays of the present exemplary embodiment each respectively have four hose connections 15X. The number of hose connections 15X may however vary, for example between two and ten. The electrode cap 1 is formed as a tubular network of electrode arrays 10, 10R connected together by hose connections 16. In this preferred embodiment of the invention, the hose connections 16 may be reversibly released from the connectors 15X. As shown in FIG. 2, there is the possibility that the individual hose

connections 16R may open into T-junctions adjacent to the containers 15 of the electrode arrays 10. In addition, there is also the possibility that individual hose connections 16 may be connected to an external inflow hose and an external outflow hose, via which fluid may be pumped into the electrode cap 1 or the hose network, or via which fluid may be pumped out from the hose network or the electrode cap 1.

[0033] FIG. 3 shows an EEG measuring arrangement 100 corresponding to an exemplary embodiment of the invention. This EEG measuring arrangement 100 comprises an electrode cap 1 as shown in FIGS. 1 and 2 and a measuring device 18 for measuring electrical voltages or voltage signals. The individual electrodes 12, 13 of the electrode arrays 10 are electrically connected to the measuring device 18. The electrodes 12R of the reference electrode array 10R are also connected to the electrical measuring device 18. In this specific case, the two electrodes 12R, 13R of the reference electrode array 10R are connected to the reference potential of the measuring device 18. The measuring device 18 continuously determines the individual voltages applied to the electrodes 12, 13 and thus provides signals V_s, V_{ref} . The EEG measuring arrangement 100 comprises a processing unit 19, which is downstream of the electrical measuring arrangement. This processing unit 19 relates the individual electrical signals V_s, V_{ref} received by the measuring device 18 and which are applied to the measurement electrode 12 and the reference electrode 13 of the same electrode array 10 respectively. In a preferred embodiment of the invention, the two signals are subtracted from one another and thus a cleaned signal V is formed, which is provided at the output.

1-10. (canceled)

11. An electrode cap, comprising:

electrode arrays to be applied to a subject's head, each of said electrode arrays containing:

an insulating layer;

two electrodes disposed opposite one another on said insulating layer, said two electrodes include a first measurement electrode facing toward the subject's head and a second electrode facing away from the subject's head; and

a conductive body abutting said second electrode and in electrical contact therewith, said conductive body disposed on a side of said second electrode that faces away from the subject's head, and

said conductive body is electrically connected to said conductive body of other ones of said electrode arrays.

12. The electrode cap according to claim 11, further comprising a reference electrode array for applying to the subject's head, said reference electrode array having at least one reference electrode that faces toward the subject's head and is electrically connected to said conductive bodies of said electrode arrays.

13. The electrode cap according to claim 12, wherein said reference electrode array contains:

a reference insulating layer;

two reference electrodes disposed opposite one another on said reference insulating layer, and including a first reference electrode facing toward the subject's head and a second reference electrode facing away from the subject's head, said first and second reference electrodes are electrically connected; and

a conductive reference body abutting said second electrode and in electrical contact with said second elec-

trode, said conductive reference body is disposed on a side of said second reference electrode that faces away from the subject's head, said conductive reference body of said reference electrode array is electrically connected to said conductive bodies of said electrode arrays.

14. The electrode cap according to claim **13**, wherein at least one of said conductive body or said reference conductive body is formed by a fluid that is in electrical contact with said second electrode and/or said second reference electrode, and/or said conductive body and/or said reference conductive body has a specific conductivity of between 2 mS/cm and 40 mS/cm.

15. The electrode cap according to claim **14**, wherein at least one of said electrode arrays or said reference electrode array each respectively has a container bounded by said second electrode or said second reference electrode, in which said fluid is contained, and said container of each of said electrode arrays and/or said reference electrode array are connected and thus form vessels communicating with each other.

16. The electrode cap according to claim **15**, further comprising hose connections and the electrode cap is formed as a tubular network of said electrode arrays connected to one another via said hose connections, wherein said containers of said electrode arrays have connectors for connecting with said hose connections.

17. The electrode cap according to claim **13**, wherein at least one of said electrode arrays has a recess formed therein for receiving a conductive gel, said recess being bounded by said first measurement electrode and being open toward the subject's head.

18. The electrode cap according to claim **14**, said fluid is a saline solution.

19. The electrode cap according to claim **15**, further comprising hose connections connecting said containers to each other.

20. The electrode cap according to claim **16**, wherein said connectors connect reversibly with said hose connections.

21. The electrode cap according to claim **17**, wherein said reference electrode array has a reference recess formed therein for receiving said conductive gel, said reference recess being bounded by said first reference electrode and being open toward the subject's head.

22. An electroencephalogram measuring configuration comprising:

an electrode cap containing electrode arrays to be applied to a subject's head, each of said electrode arrays having

an insulating layer, two electrodes disposed opposite one another on said insulating layer, said two electrodes having a first measurement electrode facing toward the subject's head and a second electrode facing away from the subject's head, and a conductive body abutting said second electrode and in electrical contact therewith, said conductive body disposed on a side of said second electrode that faces away from the subject's head, and said conductive body is electrically connected to said conductive body of other ones of said electrode arrays;

an electrical measuring device; and

said electrodes of said electrode arrays are electrically connected to said electrical measuring device for measuring voltages and/or electrical signals applied to said electrodes.

23. The EEG measuring configuration according to claim **22**, further comprising a processing unit that relates the electrical signals that are present respectively at said first measurement electrode and said second electrode of a same one of said electrode arrays to each other, and subtracts the two electrical signals from each other, and thus creates a cleaned signal for said same one electrode array.

24. The EEG measuring configuration according to claim **22**, wherein said electrode cap contains a reference electrode array for applying to the subject's head, said reference electrode array having:

a reference insulating layer;

two reference electrodes disposed opposite one another on said reference insulating layer, and including a first reference electrode facing toward the subject's head and a second reference electrode facing away from the subject's head, said first and second reference electrodes are electrically connected; and

a conductive reference body abutting said second electrode and in electrical contact therewith, said conductive reference body is disposed on a side of said second reference electrode that faces away from the subject's head, said conductive reference body of said reference electrode array is electrically connected to said conductive body of said electrode arrays.

25. The EEG measuring configuration according to claim **24**, wherein said at least one reference electrode or said two reference electrodes of said reference electrode array are connected to a reference potential of said electrical measuring device.

* * * * *

| | | | |
|----------------|---|---------|------------|
| 专利名称(译) | 电极帽 | | |
| 公开(公告)号 | US20190082994A1 | 公开(公告)日 | 2019-03-21 |
| 申请号 | US16/083579 | 申请日 | 2017-03-06 |
| [标]申请(专利权)人(译) | 微阁CHRISTOPH EDLINGER GUENTER | | |
| 申请(专利权)人(译) | 微阁, CHRISTOPH EDLINGER, GUENTER | | |
| 当前申请(专利权)人(译) | 微阁, CHRISTOPH EDLINGER, GUENTER | | |
| [标]发明人 | GUGER CHRISTOPH EDLINGER GUENTER | | |
| 发明人 | GUGER, CHRISTOPH EDLINGER, GUENTER | | |
| IPC分类号 | A61B5/0408 A61B5/0428 A61B5/0488 A61B5/05 A61B5/00 | | |
| CPC分类号 | A61B5/04085 A61B5/0428 A61B5/0488 A61B5/05 A61B5/6814 A61B5/6803 A61B5/6831 A61B2562/164 A61B5/0478 A61B2562/0209 | | |
| 优先权 | 2016050198 2016-03-09 AT | | |
| 外部链接 | Espacenet USPTO | | |

摘要(译)

电极帽包含至少一个电极阵列并且应用于受试者的头部。电极阵列包含绝缘层，在绝缘层上彼此相对设置的两个电极，即面向受试者头部的第一测量电极和背离受试者头部的参考电极。导体邻接参考电极并与其电接触，并且布置在参考电极的背离受试者头部的一侧。所有电极阵列的各个导体彼此电连接。

