



US 20150005608A1

(19) **United States**  
(12) **Patent Application Publication**  
**EVANS et al.**

(10) **Pub. No.: US 2015/0005608 A1**  
(43) **Pub. Date: Jan. 1, 2015**

(54) **ELECTRODE UNITS FOR SENSING  
PHYSIOLOGICAL ELECTRICAL ACTIVITY**

*A61B 5/0408* (2006.01)  
*A61B 5/0416* (2006.01)

(71) Applicant: **EasyG LLC**, Beverly Hills, MI (US)

(52) **U.S. Cl.**  
CPC ..... *A61B 5/18* (2013.01); *A61B 5/04085*  
(2013.01); *A61B 5/0478* (2013.01); *A61B*  
*5/0496* (2013.01); *A61B 5/0492* (2013.01);  
*A61B 5/7203* (2013.01); *A61B 5/6843*  
(2013.01); *A61B 5/6804* (2013.01); *A61B*  
*5/0416* (2013.01); *A61B 5/04012* (2013.01);  
*A61B 5/0006* (2013.01); *A61B 5/044*  
(2013.01); *A61B 5/4809* (2013.01); *A61B*  
*5/0452* (2013.01); *A61B 5/02042* (2013.01);  
*A61B 5/165* (2013.01); *A61B 5/08* (2013.01);  
*A61B 5/6893* (2013.01)  
USPC ..... **600/383**; 600/393; 600/382; 600/386;  
600/388; 600/372; 600/395

(72) Inventors: **Thomas Crannell EVANS**, Beverly Hills, MI (US); **Efraim GAVRILOVICH**, Vancouver (CA); **Rasvan Catalin MIHAI**, Vancouver (CA); **Ion ISBASESCU**, Burnaby (CA)

(21) Appl. No.: **14/459,142**

(22) Filed: **Aug. 13, 2014**

**Related U.S. Application Data**

(63) Continuation-in-part of application No. 14/377,255, filed on Aug. 7, 2014, filed as application No. PCT/US2013/025432 on Feb. 8, 2013.

(60) Provisional application No. 61/596,543, filed on Feb. 8, 2012.

**Publication Classification**

(51) **Int. Cl.**  
*A61B 5/18* (2006.01)  
*A61B 5/0478* (2006.01)  
*A61B 5/0496* (2006.01)  
*A61B 5/0492* (2006.01)  
*A61B 5/00* (2006.01)  
*A61B 5/08* (2006.01)  
*A61B 5/04* (2006.01)  
*A61B 5/044* (2006.01)  
*A61B 5/0452* (2006.01)  
*A61B 5/02* (2006.01)  
*A61B 5/16* (2006.01)

(57) **ABSTRACT**

Systems and apparatus for monitoring physiological electrical activity of an individual include a first electrode unit for receiving a first signal indicative of electrical activity at a first location on a body of the individual and a second electrode unit for receiving a second signal indicative of electrical activity at a second location on the body of the individual. Each of the first and second electrode units may be operated in a field-sensing mode wherein the electrode unit is placed on or in proximity to the individual's skin. The first and second electrode units comprise a capacitive sensor element, and the capacitive sensor element of each of the electrode units comprising an electrodynamic sensor which is sensitive to electromagnetic waves; and an antenna comprising an electrically conductive radiating element for receiving electromagnetic waves. The field-sensing mode can be either non-contact field-sensing mode wherein the electrode unit is placed on the individual's clothing or a contact field-sensing mode wherein the electrode unit is placed directly on the individual's skin.

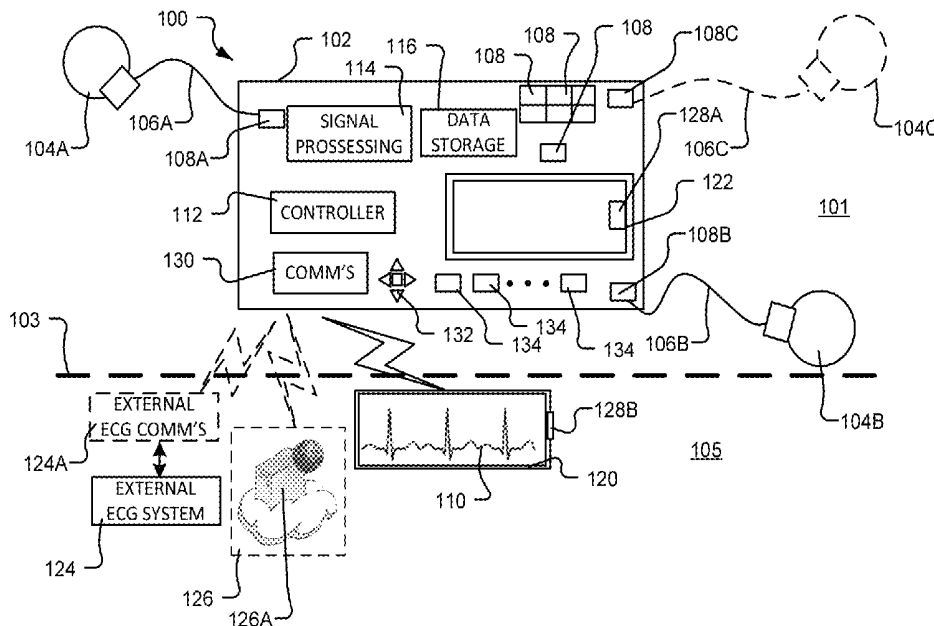

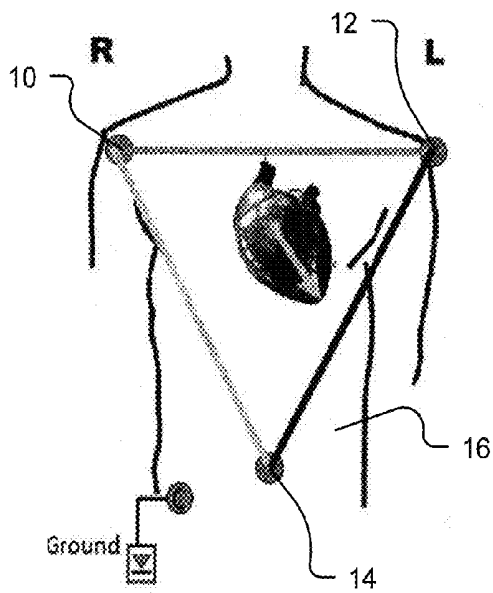

FIGURE 1

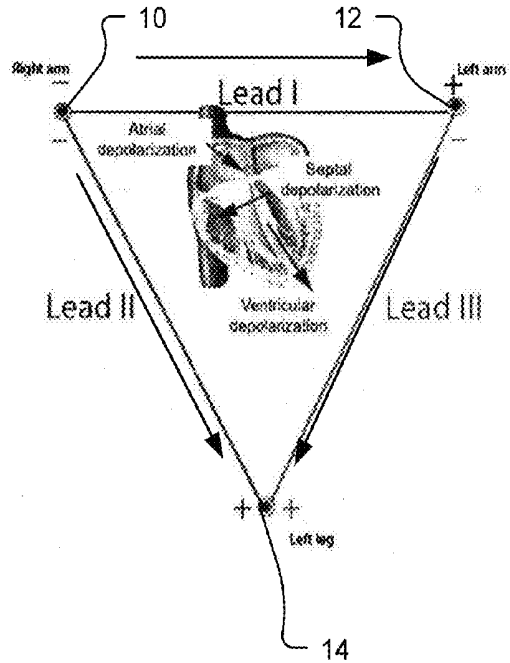

FIGURE 2

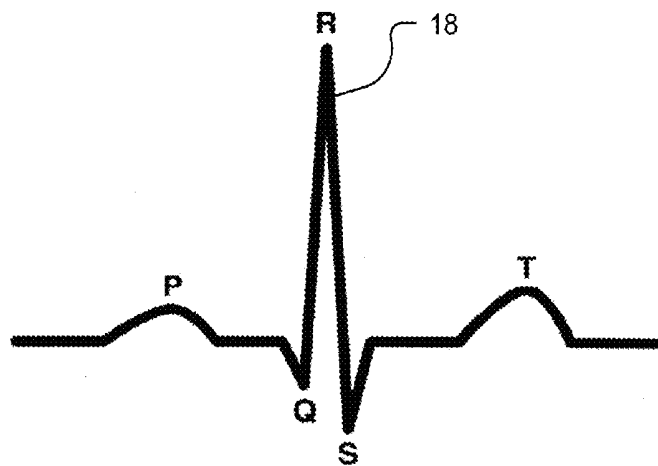
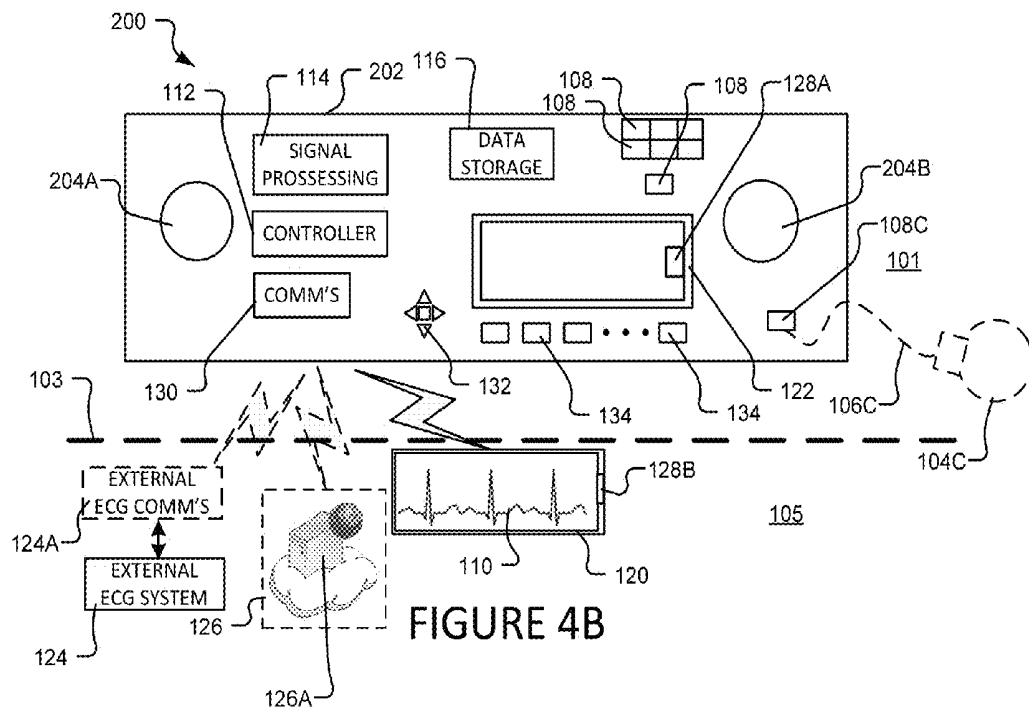
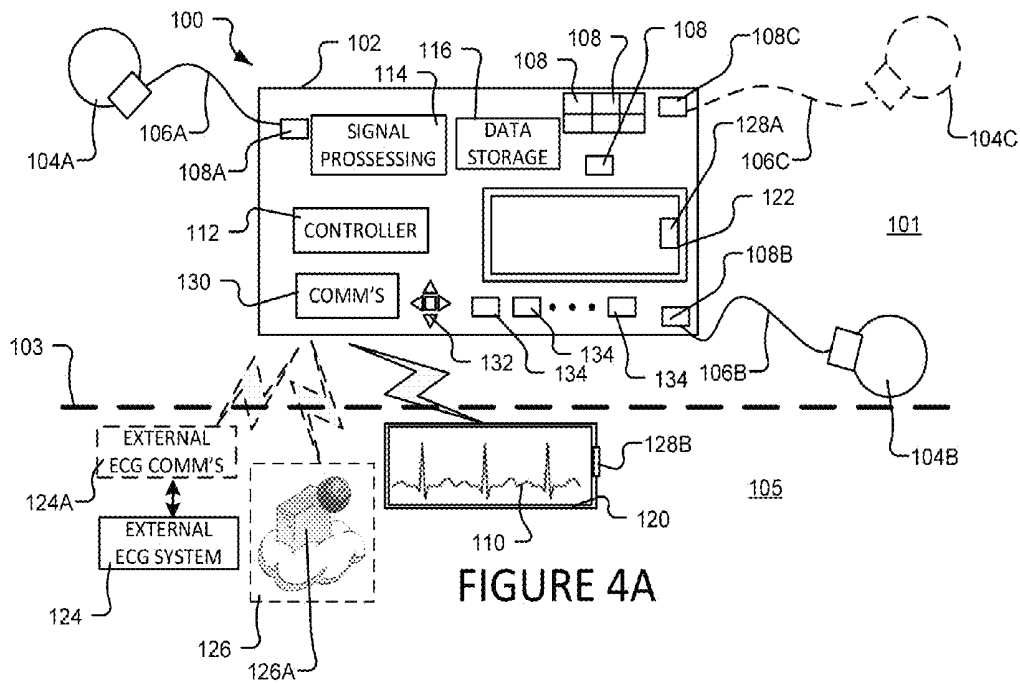
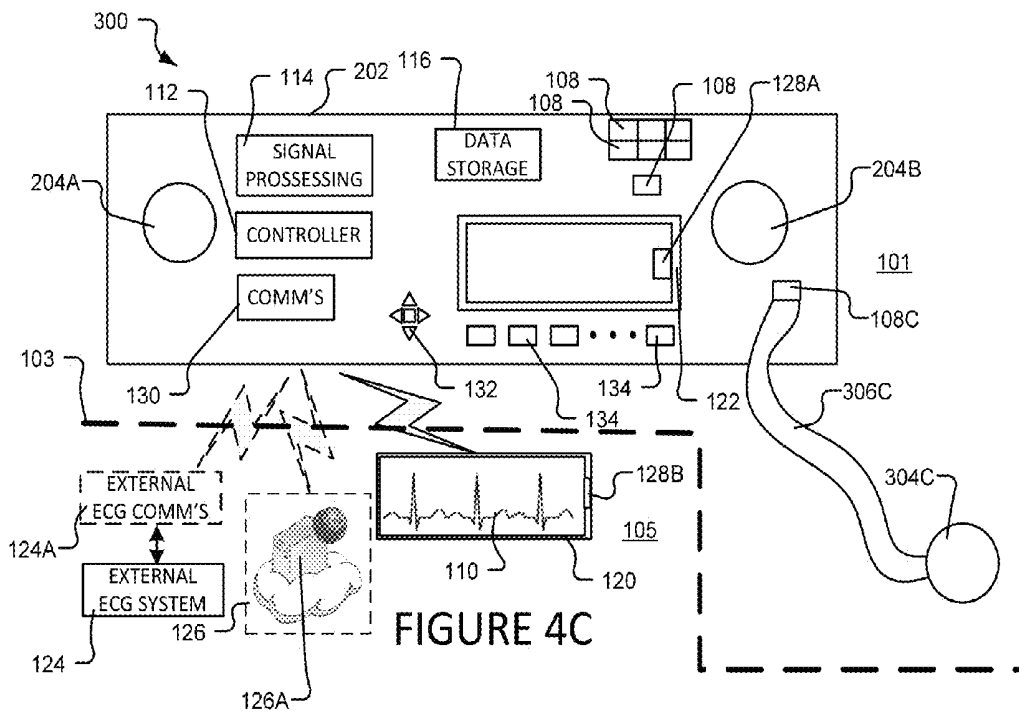

FIGURE 3





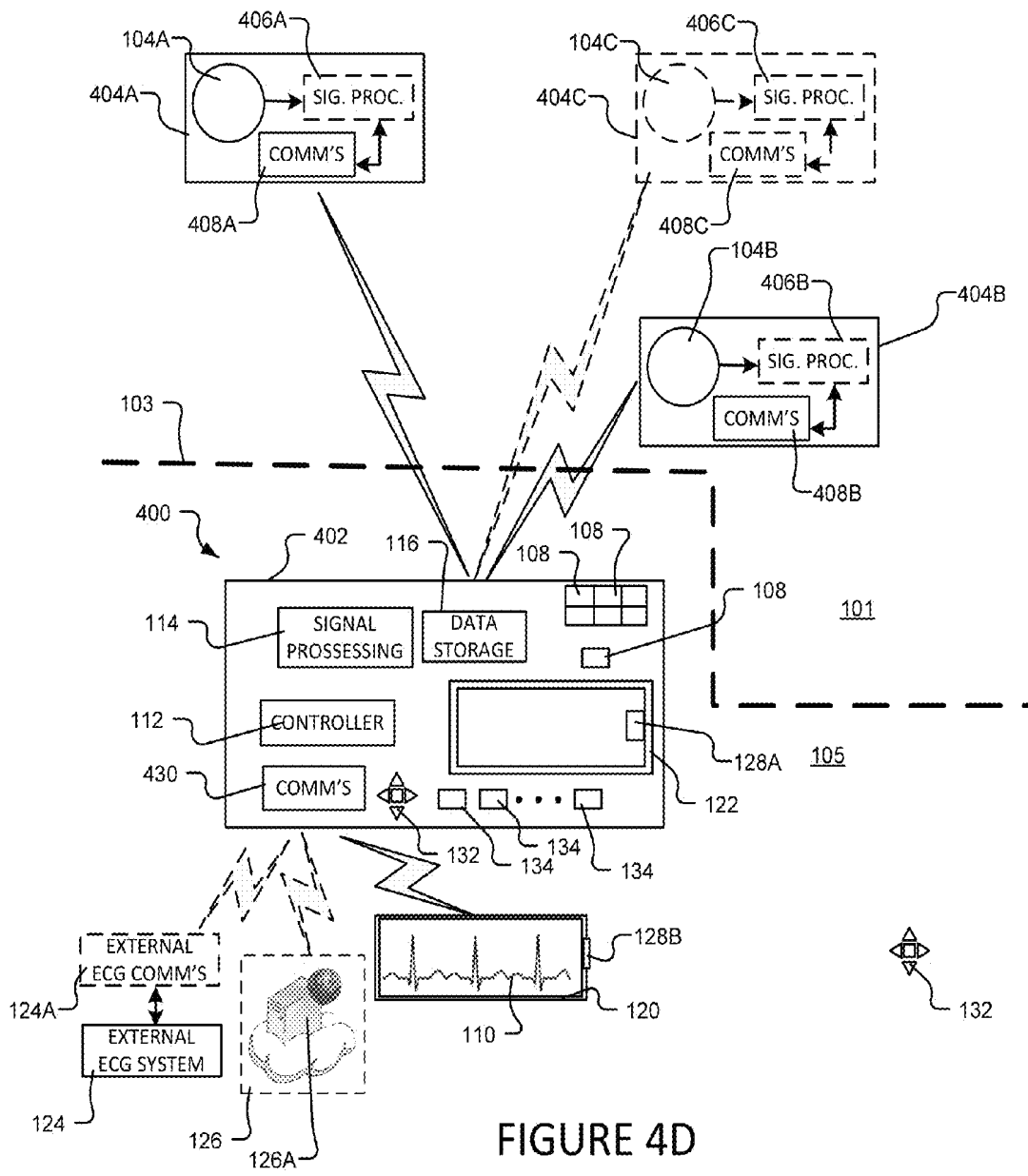

FIGURE 4D

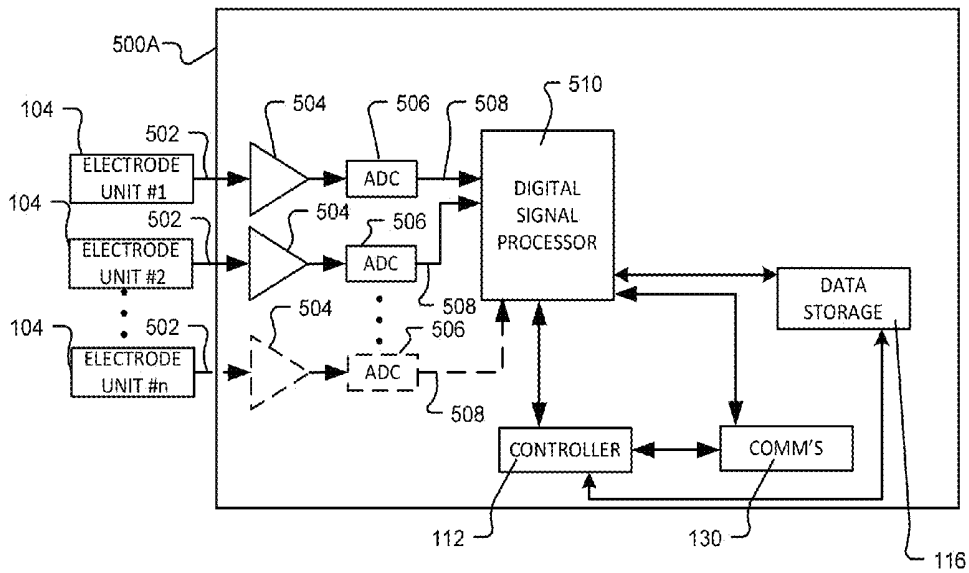

FIGURE 5A

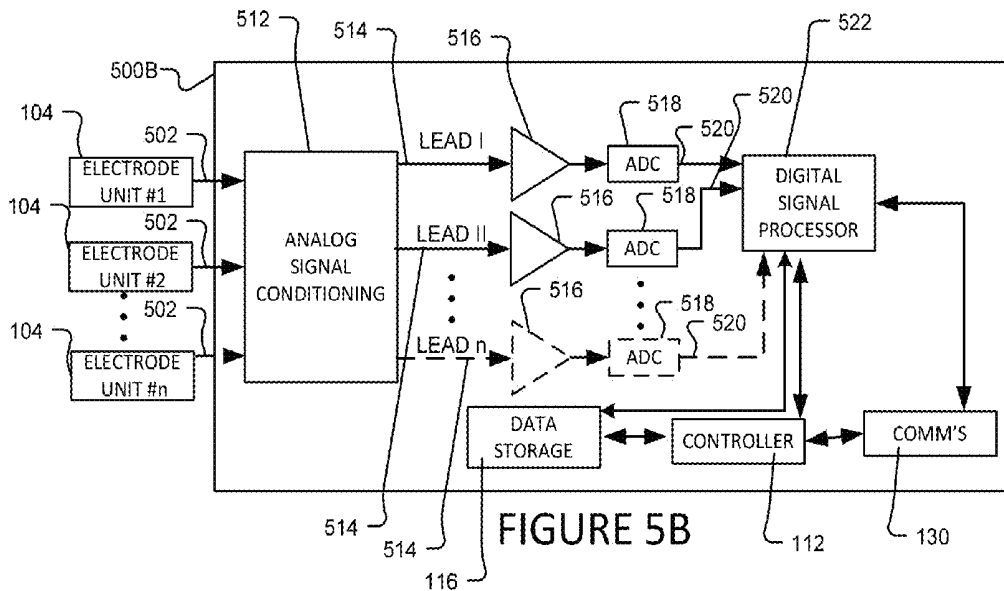

FIGURE 5B

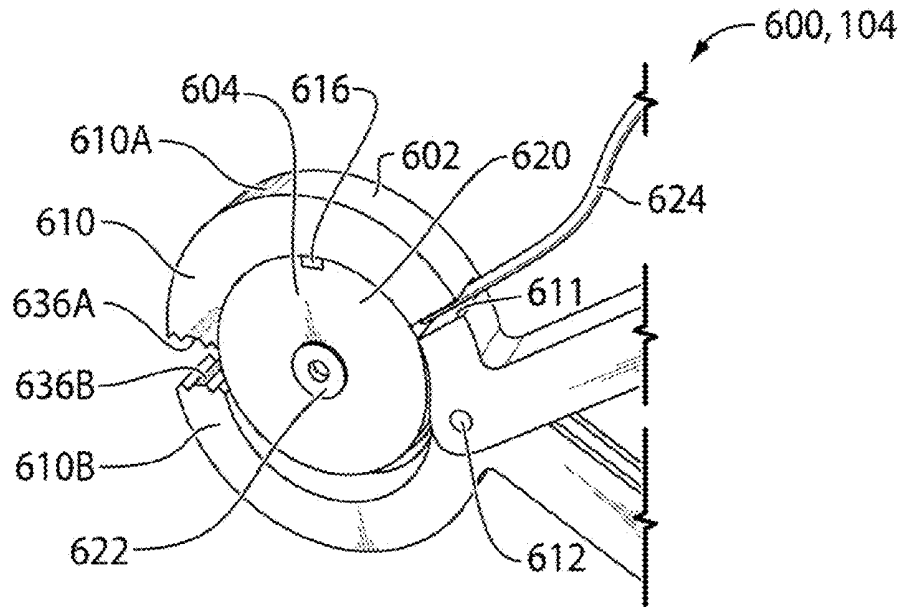

FIG. 6A

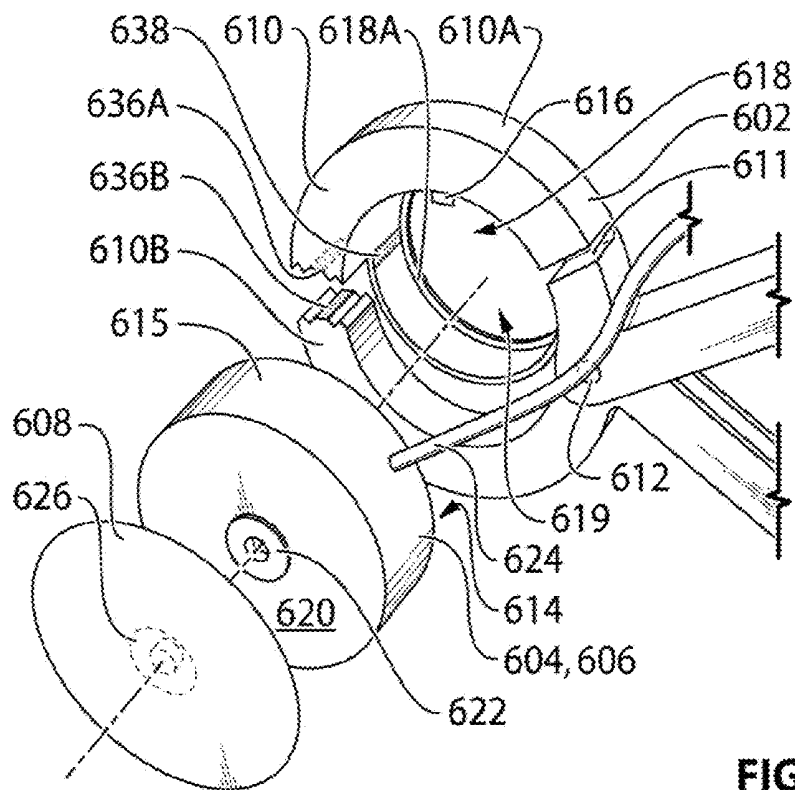

FIG. 6B

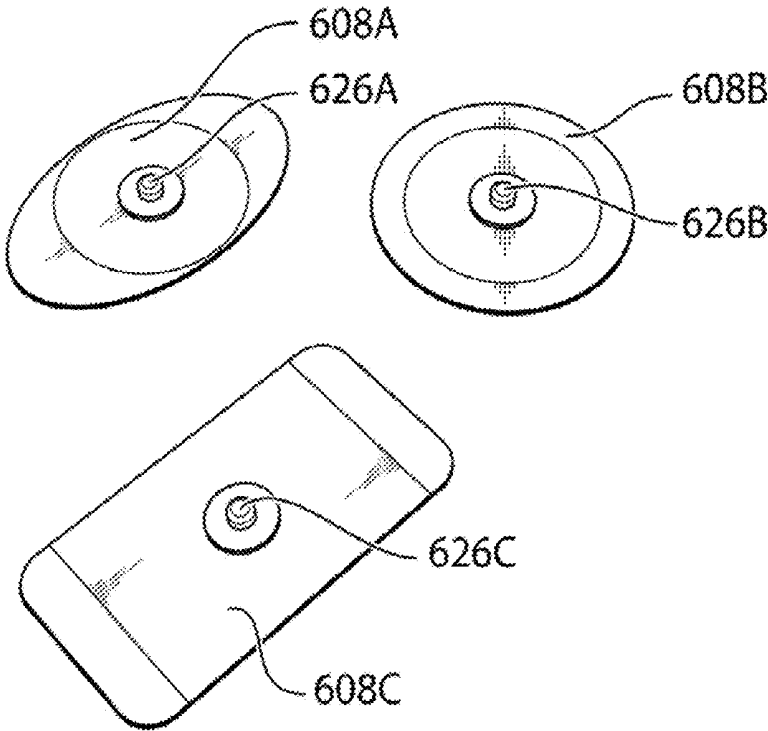

FIG. 7A

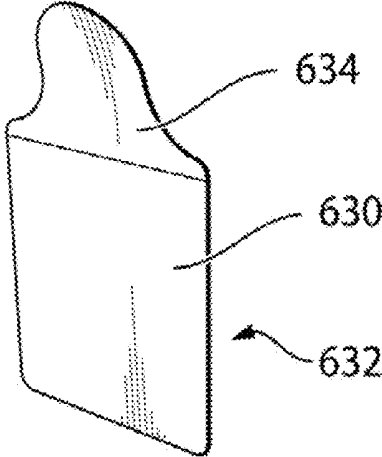

FIG. 7B

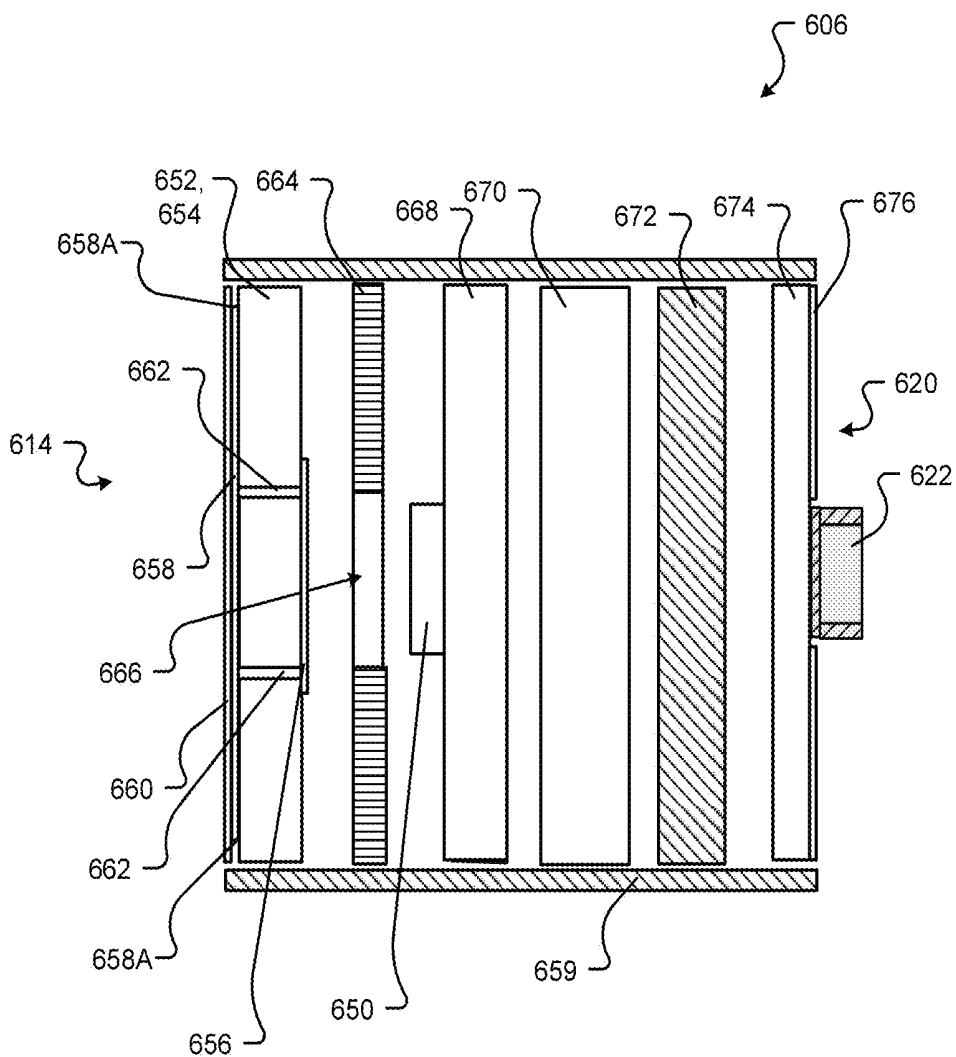

FIG. 8

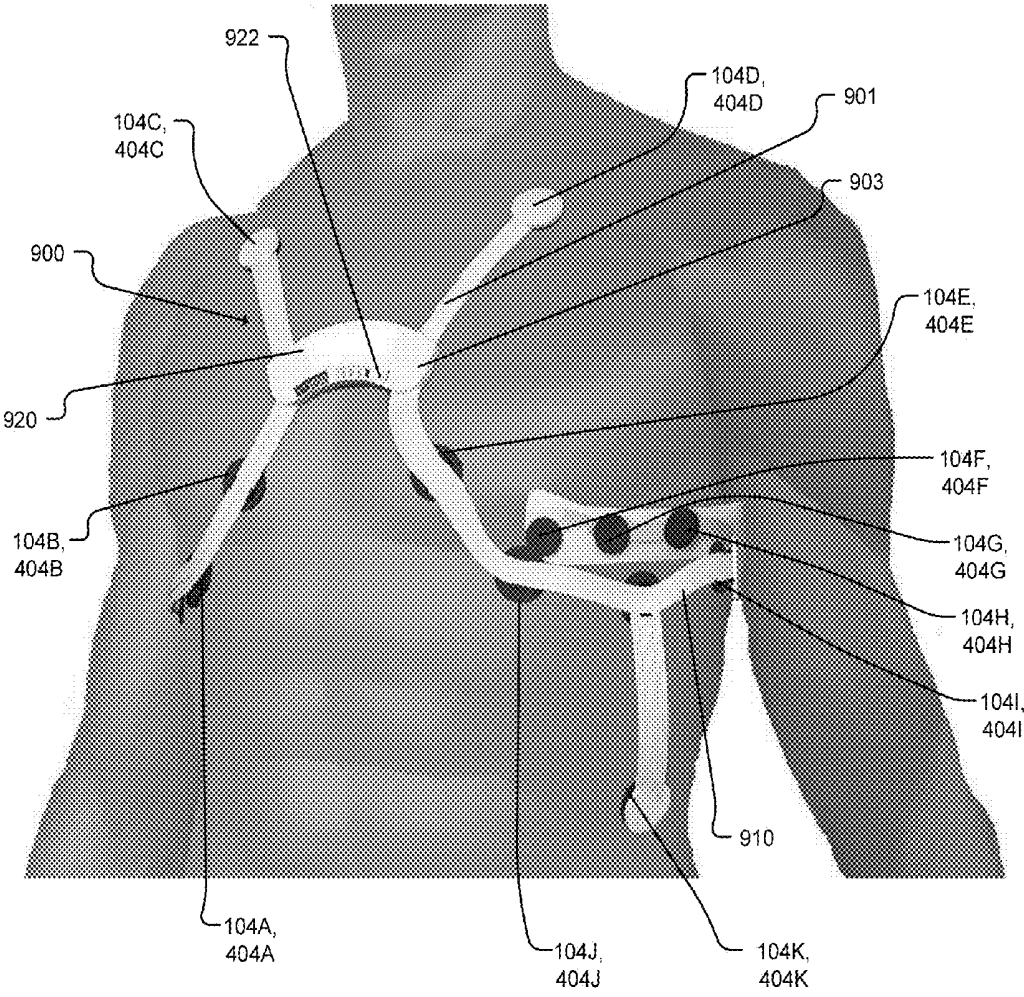

FIG. 9

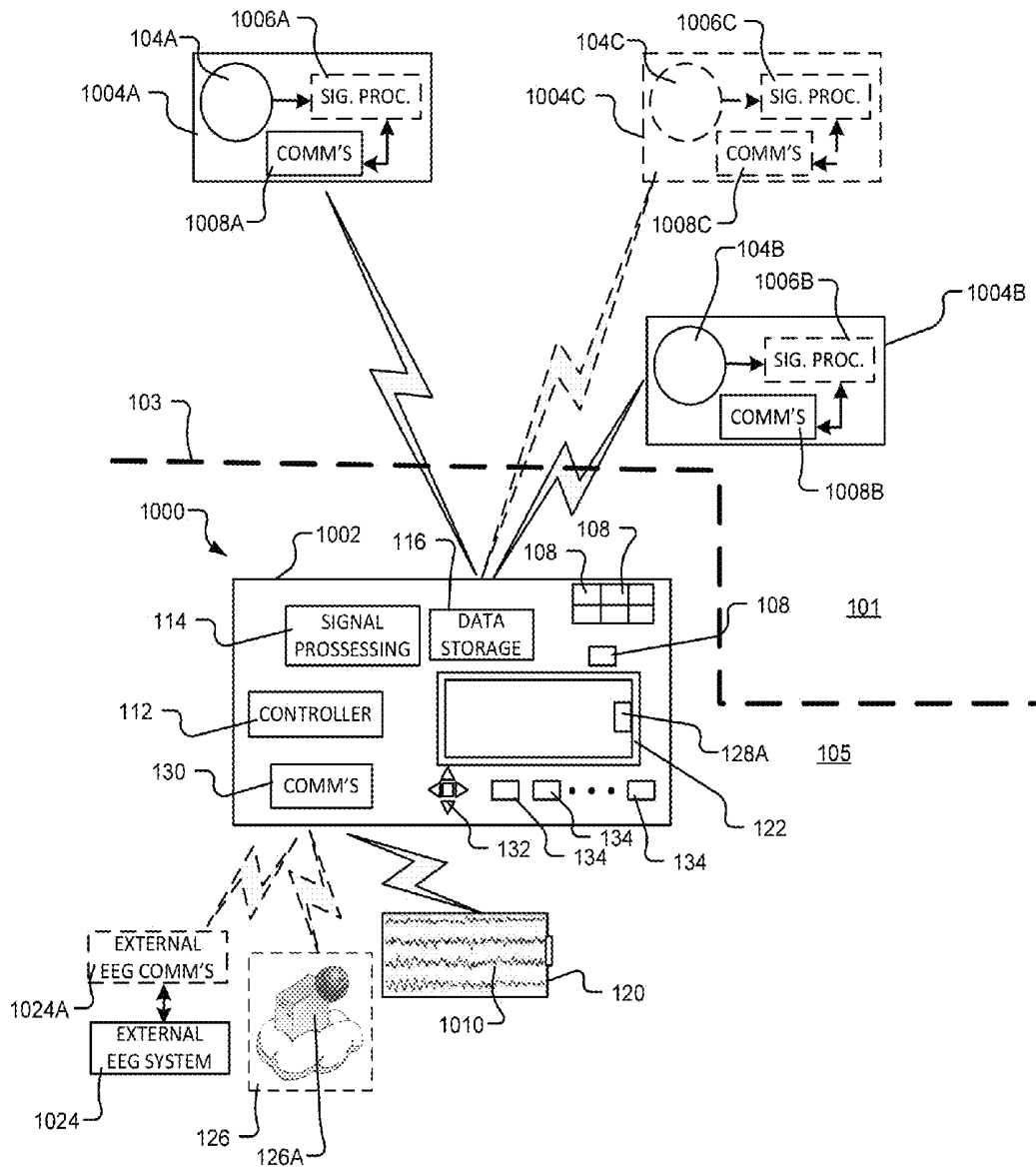

FIGURE 10

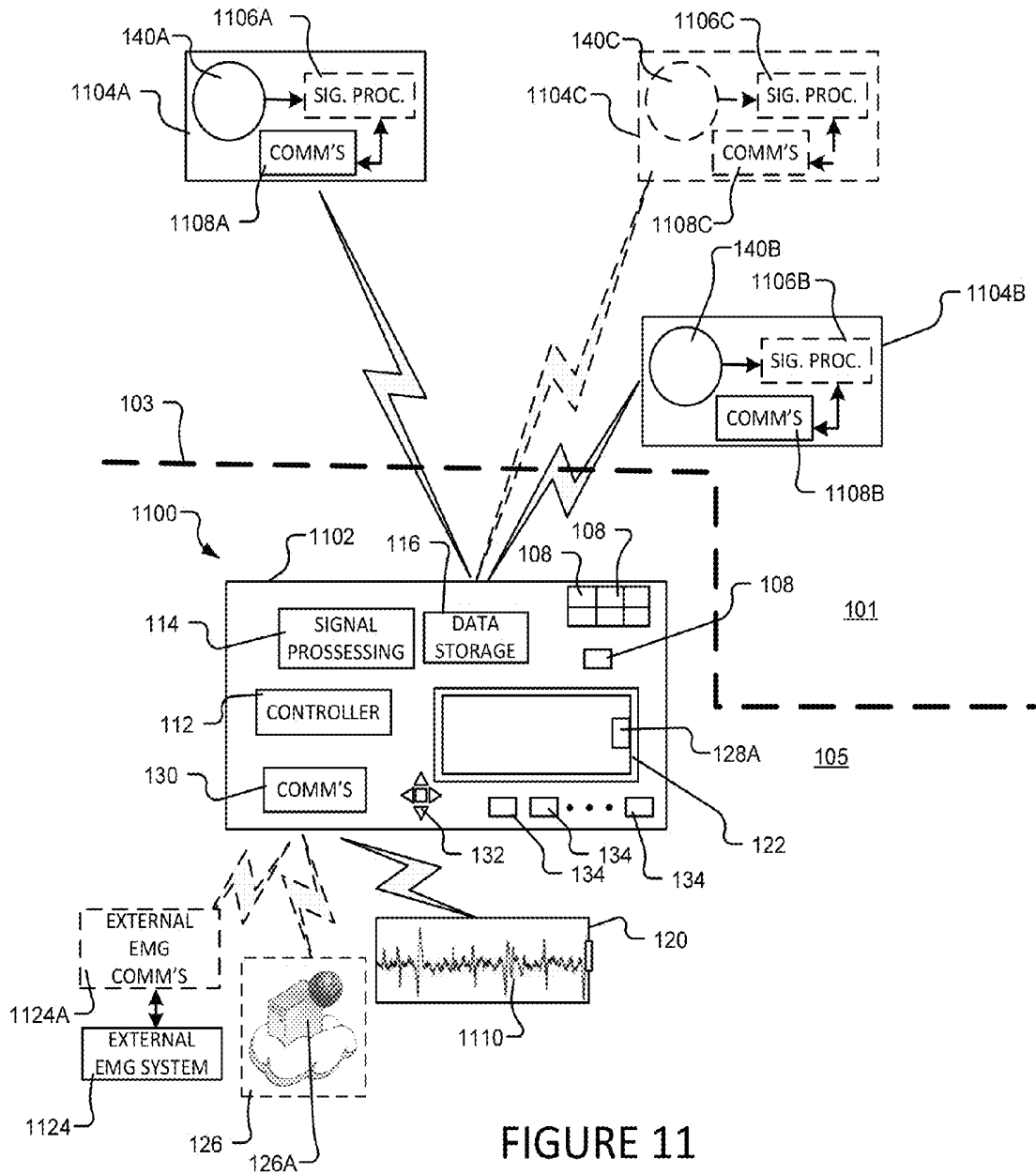

FIGURE 11

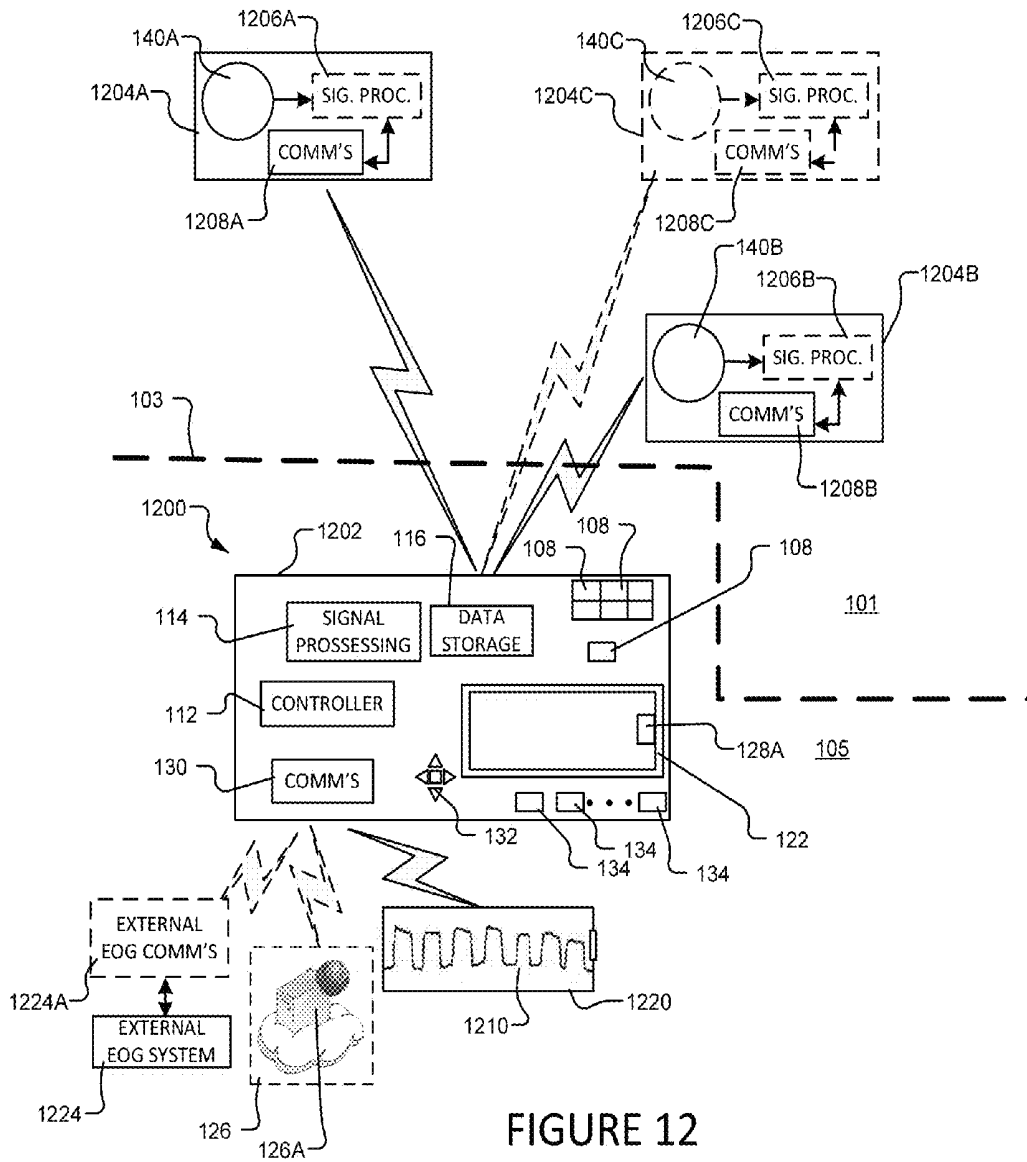

FIGURE 12

## ELECTRODE UNITS FOR SENSING PHYSIOLOGICAL ELECTRICAL ACTIVITY

### CROSS-REFERENCE TO RELATED APPLICATION

[0001] This is a continuation-in-part of U.S. patent application Ser. No. 14/377,255 which is a 35 U.S.C. §371 national phase entry application of Patent Cooperation Treaty Application No. PCT/US2013/025432 filed 8 Feb. 2013 entitled ECG SYSTEM WITH MULTI MODE ELECTRODE UNITS, which in turn claims priority from U.S. provisional application No. 61/596,543 filed 8 Feb. 2012 entitled REMOTE MONITORING ECG SYSTEM. PCT/US2013/025432 and US61/596,543 are both hereby incorporated herein by reference.

### TECHNICAL FIELD

[0002] The technology described herein relates to electrocardiography (ECG) systems, electroencephalography (EEG) systems, electromyography (EMG) systems, electrooculography (EOG) systems and/or similar systems, which detect physiological electrical activity at locations on, or within, an individual's body.

### BACKGROUND

[0003] A conventional ECG system typically consists of between 3 and 10 electrodes placed on areas of an individual's body to detect electrical activity. The electrodes are connected to an ECG monitor by a commensurate number of wires/cables. A conventional ECG electrode typically comprises a resistive sensor element which is placed directly against the individual's skin. A number of electrodes are placed against the individual's skin to detect the electrical characteristics of the heart (e.g. the current through or voltage across the resistive sensor element) at desired vantage points on the individual's body. The detected signals are relayed through the wires to the ECG monitor, which is typically located on a lab table or the like, away from the individual's body. A signal processing unit within the ECG monitor processes the signals to generate an ECG waveform which can be displayed on a display of the ECG monitor.

[0004] FIGS. 1 and 2 show three electrodes 10, 12, 14 arranged in the so-called Einthoven's triangle on an individual's body 16. As is known in the art, electrodes 10, 12 and 14 may be respectively referred to as the Right Arm (RA), Left Arm (LA) and Left Leg (LL) electrodes because of the locations that they are commonly placed on body 16. To generate an ECG signal, various potential differences are determined between the signals from electrodes 10, 12, 14. These potential differences are referred to as "leads". Leads have polarity and associated directionality. The common leads associated with the Einthoven's triangle shown in FIGS. 1 and 2 include: lead I (where the signal from RA electrode 10 is subtracted from the signal from LA electrode 12); lead II (where the signal from RA electrode 10 is subtracted from the signal from LL electrode 14); and lead III (where the signal from LA electrode 12 is subtracted from the signal from LL electrode 14). In addition to the leads shown in FIG. 2, other common leads associated with the Einthoven's triangle configuration include: the AVR lead (where one half of the sum of the signals from LA and LL electrodes 12, 14 is subtracted from the signal for RA electrode 10); the AVL lead (where one half of the sum of the signals from RA and LL electrodes 10, 14 is

subtracted from the signal for LA electrode 12); and the AVF lead (where one half of the sum of the signals from RA and LA electrodes 10, 12 is subtracted from the signal for LL electrode 14). As is known in the art, the AVR lead is oriented generally orthogonally to lead III, the AVL lead is oriented generally orthogonally to lead II and the AVF lead is oriented generally orthogonally to lead I. The signals from each of these leads can be used to produce an ECG waveform 18 as shown in FIG. 3. Additional sensors can be added to provide different leads which may be used to obtain different views of the heart activity. For example, as is well known in the art, sensors for precordial leads V1, V2, V3, V4, V5, V6 may be added and such precordial leads may be determined to obtain the so-called 12 lead ECG.

[0005] Some issues with traditional ECG technology make it an impediment for use, particularly in emergency response situations. The multiple electrodes and their corresponding wires may require extensive time to set up which may be critical in emergency circumstances. Having to maneuver around and detangle a large number of wires can be a nuisance. Multiple electrodes and wires can make it difficult to move an individual or administer medical aid to an individual. Signal noise from movement of the wires and wire tension can also degrade the quality of the ECG reading. Multiple wires can be particularly problematic during cardiac monitoring, where the ECG wires are attached to an individual for a long time. These issues with traditional ECG technology are exacerbated where there is a significant distance between the individual and the ECG monitor (i.e. where the electrode wires are long). EEG systems (which measure electrical activity of the brain), EMG systems (which measure electrical activity of skeletal and/or other muscles) and/or EOG systems (which measure electrical activity within the eye) may face similar problems.

[0006] In addition to the problems with wires, current ECG systems use contact electrodes with resistive sensor elements. Such contact electrodes must be placed in direct contact with the individual's skin to obtain accurate signals. Typically, these contact electrodes are stuck to the individual's skin using an adhesive. The use of contact electrodes can be problematic in some circumstances. By way of non-limiting example, it may be undesirable or difficult to remove the individual's clothing in certain situations—e.g. where the individual may have privacy concerns, where the individual is suspected of having a spinal cord injury and/or the like. As another example, the individual may have a condition which makes it undesirable or difficult to apply current-sensing electrodes to the skin—e.g. the individual is suffering from burns to the individual's skin, the individual has body hair which must be removed prior to using the contact electrodes, the individual is allergic to the adhesive and/or the like. Also, EEG systems often require conductive gels to be used between the sensor and the skin of the individual and/or abrasion of the individual's skin to create electrical contact between the sensor and the skin. It can take a long time (e.g. up to an hour or more) to apply the gel into EEG caps and/or nets that are used in EEG sensing systems. The gel used in EEG systems can diffuse through hair to create shorts between sensors and can dry out over time. Whether gel-coated or not, the caps or nets which hold EEG sensors in contact with skin can be uncomfortable for the individual being tested, making long term monitoring (e.g. a desire when evaluating certain conditions such as epilepsy) difficult.

**[0007]** There is a general desire for improved ECG, EEG, EMG, and/or EOG systems. By way of non-limiting example, there is a general desire for an ECG system that can provide greater flexibility for use by medical professionals in a variety of different circumstances, such as might be the case for emergency response technicians (EMTs). There is a general desire for ECG, EEG, EMG and/or EOG systems that may be more convenient and/or simple to use than existing systems. There is also a general desire for improved systems for detecting electrical activity in different locations on and/or within an individual's body, such as the heart (e.g. heart muscle), brain, the eyes, and skeletal and/or other muscles.

**[0008]** The foregoing examples of the related art and limitations related thereto are intended to be illustrative and not exclusive. Other limitations of the related art will become apparent to those of skill in the art upon a reading of the specification and a study of the drawings.

#### SUMMARY

**[0009]** One aspect of the invention provides an electrode unit for sensing physiological electrical activity of an individual. Such an electrode unit may be used, for example, in an ECG, EEG, EOG, or EMG system. The electrode unit comprises a capacitive sensor element for sensing electrical field associated with the physiological electrical activity. The capacitive sensor element of the electrode unit comprises an electrodynamic sensor which is sensitive to electromagnetic waves (e.g. electric field) and an antenna comprising an electrically conductive radiating element for receiving electromagnetic waves. The radiating element is in electrical contact with a sensing surface of the electrodynamic sensor and has a surface area which is larger than a surface area of the sensing surface of the electrodynamic sensor. The antenna is located relatively more proximate than the electrodynamic sensor to the individual's skin during operation of the electrode unit in the field-sensing mode.

**[0010]** In some embodiments, the electrode unit may operate in current sensing, field-sensing non-contact, or field-sensing contact modes. In other embodiments, the electrode unit may operate in field-sensing mode only. In some embodiments, the electrode unit is incorporated into the interior of a vehicle for use with a system for sensing physiological electrical activities in an individual. In some embodiments, the electrode unit may be embedded or mounted within or incorporated in the backrest or bottom portion of a seat or chair (e.g., seats (e.g. operator seat(s) and/or other seat(s)) in a vehicle such as a car, plane, helicopter, motorcycle, truck, boat, cart, or the like, car seats, strollers, and/or the like), in the controls of a vehicle (e.g., in the handle bars of a motorcycle, in the steering wheel of a car, and/or the like), in a bed (e.g. a hospital bed, crib, bed frame, and/or the like), and/or the like. In some embodiments, the electrode unit may be embedded in seat restraints, such as a seat belt, safety belt, and the like.

**[0011]** In some embodiments, at least two of these electrode units, each comprising a capacitive sensor element that comprises an electrodynamic sensor and an antenna, are used in a system for sensing physiological electrical activities in an individual, such as an ECG, EMG, EEG, or EOG system. In some embodiments, only one such electrode unit is used in such systems. In some embodiments, a plurality of such electrode units is used in such systems. In some embodiments, to the system for sensing physiological electrical activities is incorporated into or embedded or mounted within a vehicle,

such as a car, plane, helicopter, motorcycle, truck, boat, cart, or the like, car seats, strollers, and/or the like. In some embodiments, the vehicle may be a police car, an ambulance, a fire engine, and/or the like, or a military vehicle, such as a tank, armored vehicle, infantry vehicle, amphibious vehicle, troop carrier, engineering vehicle, military aircraft and/or the like.

**[0012]** Another aspect of the invention provides a method for sensing physiological electrical activities of an individual, the method comprises the steps of providing a first electrode unit for generating a first signal indicative of the electrical activity at a first location on a body of the individual; and providing a second electrode unit for generating a second signal indicative of the electrical activity at a second location on the body of the individual. The electrode units are then operated in field-sensing mode to generate the first signal and the second signal, and the first signal and the second signal are used to generate waveforms indicative of the electrical activity. In some embodiments, one or more of the electrode units comprises a capacitive sensor element, and the capacitive sensor element comprises an electrodynamic sensor which is sensitive to electromagnetic waves, and an antenna comprising an electrically conductive radiating element for receiving electromagnetic waves.

**[0013]** In some embodiments, the method comprises providing a plurality of electrode units. In some embodiments, the electrode units operate only in field sensing mode. In some embodiments, some electrode units may operate in field sensing mode and some electrode units may operate in current sensing mode. In some embodiments, electrode units operating in field sensing mode may be in field-sensing contact mode or field-sensing non-contact mode or either mode depending on the instructions provided to the electrode units. In some embodiments, the physiological electrical activity measured comprises electrical activity of the heart muscle (ECG), the brain (EEG), skeletal muscles (EMG), or the eye (EOG).

**[0014]** In some embodiments, the method for sensing physiological electrical activity is used to sense physiological electrical activity of an individual in a vehicle, such as the vehicle operator, passenger, and/or the like. In some embodiments, the vehicle comprises a car, plane, helicopter, motorcycle, truck, boat, cart, or the like, emergency responder vehicles such as a police car, an ambulance, a fire engine, and/or the like, or a military vehicle, such as a tank, armored vehicle, infantry vehicle, amphibious vehicle, troop carrier, engineering vehicle, military aircraft and/or the like. In some embodiments, the method is used to sense physiological electrical activities of babies, infants, or young children in car seats, strollers, and/or the like.

**[0015]** Another aspect of the invention provides a system for monitoring heart muscle activity of an individual comprising: a first electrode unit for generating a first signal indicative of electrical activity of the heart muscle at a first location on a body of the individual; and a second electrode unit for generating a second signal indicative of electrical activity of the heart muscle at a second location on the body of the individual. Each of the first and second electrode units is configurable to operate in: a field-sensing mode wherein the electrode unit is configured to generate its corresponding signal based on a detected electric field at a location on or in proximity to the individual's skin; and a current-sensing mode wherein the electrode unit is configured to generate its

corresponding signal based on current flow through a resistive sensor element placed directly on the individual's skin.

**[0016]** Another aspect of the invention provides an electrode unit for use in an ECG system comprising: a capacitive sensor element for detecting electric field; a spring-biased clamp for attachment of the electrode unit to an individual's clothing when operating in a non-contact field-sensing mode; and an attachment means for physical and electrical attachment of the electrode unit to a resistive sensor element when operating in a resistive mode.

**[0017]** Another aspect of the invention provides a system for monitoring heart muscle activity of an individual comprising: a first electrode unit for generating a first signal indicative of electrical activity of the heart muscle at a first location on a body of the individual, the first electrode unit comprising a first capacitive sensing element for detecting electric field; a second electrode unit for generating a second signal indicative of electrical activity of the heart muscle at a second location on the body of the individual, the second electrode unit comprising a second capacitive sensing element for detecting electric field; and a plurality of inputs, each input adapted to receive a corresponding signal from a current-sensing electrode unit indicative of electrical activity at a corresponding location on the body of the individual.

**[0018]** Another aspect of the invention provides a system for monitoring heart muscle activity of an individual comprising: a first input for receiving a first signal indicative of electrical activity of the heart muscle at a first location on a body of the individual; a second input for receiving a second signal indicative of electrical activity of the heart muscle at a second location on the body of the individual; wherein each of the inputs is adapted to receive a signal from a field-sensing electrode unit or from a current-sensing electrode unit and the system is configured to differentiate between signals received from field-sensing electrode units and signals received from current-sensing electrode units and to generate one or more ECG waveforms based on the received signals.

**[0019]** Another aspect of the invention provides a system for monitoring heart muscle activity of an individual comprising: a first field-sensing electrode unit for generating a first signal indicative of electrical activity of the heart muscle at a first location on a body of the individual, the first field-sensing electrode unit configured to generate the first signal based on a detected electric field at a location on or in proximity to the individual's skin; and a second current-sensing electrode unit for generating a second signal indicative of electrical activity of the heart muscle at a second location on the body of the individual, the second current-sensing electrode unit configured to generate the second signal based on current flow through a resistive sensor element placed directly on the individual's skin; wherein the system is configured to combine the first signal and the second signal to generate an ECG waveform.

**[0020]** Another aspect of the invention provides a method for generating a ECG waveform related to heart muscle activity of an individual, the method comprising: providing a plurality of electrode units, each electrode unit configured to generate a corresponding signal indicative of electrical activity of the heart muscle at a corresponding location on a body of the individual; operating at least one first one of the plurality of electrode units in a field-sensing mode, wherein the at least one first one of the electrode units is configured to generate its corresponding signal based on a detected electric field at a location on or in proximity to the individual's skin;

operating at least one other one of the plurality of electrode units in a current-sensing mode, wherein the at least one other one of the plurality of electrode units is configured to generate its corresponding signal based on current flow through a resistive sensor element placed directly on the individual's skin; and using the signals generated by the at least one first one of the plurality of electrode units and generated by the at least one other one of the plurality of electrode units to generate one or more ECG waveforms.

**[0021]** Another aspect of the invention provides a system for monitoring physiological electrical activity of an individual (e.g. of an organ, such as the heart (e.g. the heart muscle), brain, eye, or skeletal and/or other muscle) comprising: a first electrode unit for generating a first signal indicative of the physiological electrical activity (e.g. electrical activity of the heart muscle, brain, eye, or skeletal and/or other muscle, as applicable) at a first location on a body of the individual; and a second electrode unit for generating a second signal indicative of physiological electrical activity (e.g. electrical activity of the heart muscle, brain, eye, or skeletal and/or other muscle, as applicable) at a second location on the body of the individual. Each of the first and second electrode units is configurable to operate in: a field-sensing mode wherein the electrode unit is configured to generate its corresponding signal based on a detected electric field at a location on or in proximity to the individual's skin; and a current-sensing mode wherein the electrode unit is configured to generate its corresponding signal based on current flow through a resistive sensor element placed directly on the individual's skin.

**[0022]** Another aspect of the invention provides an electrode unit for use in a system for measuring physiological electrical activity (e.g. an ECG, EEG, EMG and/or EOG system) comprising: a capacitive sensor element for detecting electric field; a spring-biased clamp for attachment of the electrode unit to an individual's clothing when operating in a non-contact field-sensing mode; and an attachment means for physical and electrical attachment of the electrode unit to a resistive sensor element when operating in a resistive mode.

**[0023]** Another aspect of the invention provides a system for monitoring physiological electrical activity of an individual (e.g. electrical activity of an organ, such as the heart (e.g. the heart muscle), brain, eye, or skeletal and/or other muscle) comprising: a first electrode unit for generating a first signal indicative of the physiological electrical activity (e.g. electrical activity of the heart muscle, brain, eye, or skeletal and/or other muscle, as applicable) at a first location on a body of the individual, the first electrode unit comprising a first capacitive sensing element for detecting electric field; a second electrode unit for generating a second signal indicative of the physiological electrical activity (e.g. electrical activity of the heart muscle, brain, eye, or skeletal and/or other muscle, as applicable) at a second location on the body of the individual, the second electrode unit comprising a second capacitive sensing element for detecting electric field; and a plurality of inputs, each input adapted to receive a corresponding signal from a current-sensing electrode unit indicative of electrical activity at a corresponding location on the body of the individual.

**[0024]** Another aspect of the invention provides a system for monitoring physiological electrical activity of an individual (e.g. electrical activity of an organ, such as the heart (e.g. the heart muscle), brain, eye, or skeletal and/or other muscle) comprising: a first input for receiving a first signal

indicative of the physiological electrical activity of the individual (e.g. electrical activity of the heart muscle, brain, eye, or skeletal and/or other muscle, as applicable) at a first location on a body of the individual; a second input for receiving a second signal indicative of the physiological electrical activity of the individual (e.g. electrical activity of the heart muscle, brain, eye, or skeletal and/or other muscle, as applicable) at a second location on the body of the individual; wherein each of the inputs is adapted to receive a signal from a field-sensing electrode unit or from a current-sensing electrode unit and the system is configured to differentiate between signals received from field-sensing electrode units and signals received from current-sensing electrode units. The system may generate one or more ECG, EEG, EOG, or EMG waveforms, as applicable, based on the received signals.

**[0025]** Another aspect of the invention provides a system for monitoring the physiological electrical activity of an individual (e.g. electrical activity of an organ, such as the heart (e.g. the heart muscle), brain, eye, or skeletal and/or other muscle) comprising: a first field-sensing electrode unit for generating a first signal indicative of the physiological electrical activity (e.g. electrical activity of the heart muscle, brain, eye, or skeletal and/or other muscle, as applicable) at a first location on a body of the individual, the first field-sensing electrode unit configured to generate the first signal based on a detected electric field at a location on or in proximity to the individual's skin; and a second current-sensing electrode unit for generating a second signal indicative of the physiological electrical activity (e.g. electrical activity of the heart muscle, brain, eye, or skeletal and/or other muscle, as applicable) at a second location on the body of the individual, the second current-sensing electrode unit configured to generate the second signal based on current flow through a resistive sensor element placed directly on the individual's skin. The system may be configured to combine the first signal and the second signal to generate an ECG, EEG, EOG, or EMG waveform, as applicable.

**[0026]** Another aspect of the invention provides a method for sensing physiological electrical activity of an individual (e.g. electrical activity in the heart (e.g. the heart muscle), brain, eye, or skeletal and/or other muscle of an individual) and, optionally, generating ECG, EEG, EOG, or EMG waveforms related to the physiological electrical activity. The method comprises: providing a plurality of electrode units, each electrode unit configured to generate a corresponding signal indicative of the physiological electrical activity (e.g. electrical activity of the heart muscle, brain, eye, or skeletal and/or other muscle, as applicable) at a corresponding location on a body of the individual; operating at least one first one of the plurality of electrode units in a field-sensing mode, wherein the at least one first one of the electrode units is configured to generate its corresponding signal based on a detected electric field at a location on, or in proximity to, the individual's skin; operating at least one other one of the plurality of electrode units in a current-sensing mode, wherein the at least one other one of the plurality of electrode units is configured to generate its corresponding signal based on current flow through a resistive sensor element placed directly on the individual's skin. The method may comprise using the signals generated by the at least one first one of the plurality of electrode units and generated by the at least one other one of the plurality of electrode units to generate one or more ECG, EEG, EOG, or EMG waveforms, as applicable

**[0027]** In addition to the exemplary aspects and embodiments described above, further aspects and embodiments will become apparent by reference to the drawings and by study of the following detailed descriptions.

#### BRIEF DESCRIPTION OF DRAWINGS

**[0028]** Exemplary embodiments are illustrated in referenced figures of the drawings. It is intended that the embodiments and figures disclosed herein are to be considered illustrative rather than restrictive.

**[0029]** FIG. 1 is a schematic illustration of the electrodes of a conventional ECG system arranged on the individual's body in an Einthoven's triangle configuration.

**[0030]** FIG. 2 is a schematic illustration of the electrodes of a conventional ECG system arranged in an Einthoven's triangle configuration and a number of the corresponding leads.

**[0031]** FIG. 3 is a typical ECG waveform of the type that might be displayed on an ECG system.

**[0032]** FIG. 4A schematically illustrates an ECG system architecture according to a particular embodiment. FIG. 4B schematically illustrates an ECG system architecture according to another particular embodiment. FIG. 4C schematically illustrates an ECG system architecture according to another particular embodiment. FIG. 4D schematically illustrates an ECG system architecture according to another particular embodiment.

**[0033]** FIG. 5A is a block diagram showing one implementation of a signal processing system for processing data from the electrode units of the FIGS. 4A-4D ECG systems according to a particular embodiment. FIG. 5B is a block diagram showing one implementation of a signal processing system for processing data from the electrode units of the FIGS. 4A-4D ECG systems according to another particular embodiment.

**[0034]** FIGS. 6A and 6B are respectively assembled and exploded isometric views of a multi-mode electrode unit according to a particular embodiment.

**[0035]** FIGS. 7A and 7B illustrate different resistive sensor elements that may be used with the FIGS. 6A, 6B electrode unit.

**[0036]** FIG. 8 is an exploded cross-sectional view of a capacitive sensor element that may be used with the FIG. 6A, 6B electrode unit according to a particular embodiment.

**[0037]** FIG. 9 illustrates a harness comprising electrode assemblies according to a particular embodiment.

**[0038]** FIG. 10 schematically illustrates an EEG system architecture according to a particular embodiment.

**[0039]** FIG. 11 schematically illustrates an EMG system architecture according to another particular embodiment.

**[0040]** FIG. 12 schematically illustrates an EOG system architecture according to another particular embodiment.

#### DESCRIPTION

**[0041]** Throughout the following description, specific details are set forth in order to provide a more thorough understanding to persons skilled in the art. However, well known elements may not have been shown or described in detail to avoid unnecessarily obscuring the disclosure. Accordingly, the description and drawings are to be regarded in an illustrative, rather than a restrictive, sense.

**[0042]** One aspect of the invention provides an electrode unit for sensing physiological electrical activity of an individual. Such an electrode unit may be used, for example, in an

ECG, EEG, EOG, or EMG system. The electrode unit comprises a capacitive sensor element for sensing electrical field associated with the physiological electrical activity. In some embodiments, the capacitive sensor element of the electrode unit comprises an electrodynamic sensor which is sensitive to electromagnetic waves (e.g. electric field) and an antenna comprising an electrically conductive radiating element for receiving electromagnetic waves. In further embodiments, the radiating element is in electrical contact with a sensing surface of the electrodynamic sensor and has a surface area which is larger than a surface area of the sensing surface of the electrodynamic sensor. The antenna may be located relatively more proximate than the electrodynamic sensor to the individual's skin during operation of the electrode unit in the field-sensing mode. In some embodiments, the electrode unit may operate in current sensing, field-sensing non-contact, and field-sensing contact modes. In other embodiments, the electrode unit may operate in field-sensing mode only. In some embodiments, the electrode unit is incorporated into systems for sensing physiological electrical activities of an individual, such as an ECG, EEG, EMG, or EOG system. In some embodiments, the electrode unit is provided as part of a method for sensing physiological electrical activities of an individual.

[0043] FIG. 4A schematically illustrates an ECG system 100 according to a particular embodiment. ECG system 100 comprises a base unit 102 and two or more electrode units 104A, 104B, 104C (collectively and individually, electrode units 104). Electrode units 104 may be located relative to an individual's body 101 (as discussed in more detail below) to generate signals indicative of electrical activity of the individual's heart at their corresponding locations. In the schematic illustration of FIG. 4A, locations 101 on the individual's body are shown as being above the thick dashed line 103 and locations 105 away from the individual's body are shown as being below the thick dashed line 103. In currently preferred embodiments, electrode units 104 are multi-function electrode units of the type described below, although this is not necessary. In the illustrated embodiment of FIG. 4A, ECG system 100 is shown as having three electrode units 104A, 104B, 104C which may be used in an Einthoven's triangle configuration. In some embodiments, third electrode unit 104C is not necessary and system 100 may use as few as two electrode units 104. In some embodiments, system 100 may be provided with more than three electrode units 104 (as discussed in more detail below) to provide additional leads and corresponding additional views of heart muscle electrical activity. In some embodiments, discussed in more detail below, electrode units 104 may additionally or alternatively be used to sense other types of electrically-based physiological phenomena (referred to herein as physiological electrical activity), such as, by way of non-limiting example, electrical activity of the brain (e.g. EEG data), electrical activity associated with skeletal muscles (e.g. EMG data), electrical activity of the eye (e.g. EOG data) and/or the like.

[0044] In the FIG. 4A embodiment, electrode units 104 are removably connected to base unit 102 by corresponding cables 106A, 106B, 106C (collectively and individually, cables 106) which may be removably connected to base unit 102 using suitable electrical, signal transmission connectors 108A, 108B, 108C (collectively and individually, connectors 108). Connectors 108 may comprise, for example: slidable locking electric connectors, spring-biased electric connectors, magnetic connectors and/or the like. Base unit 102 is

preferably constructed to be sufficiently small and lightweight that it can comfortably rest on an individual's body 101 without discomfort and without impacting the individual's ECG waveform. By way of non-limiting example, base unit 102 could be rested on an individual's chest, strapped or clipped (using suitable straps (not shown) or clips (not shown)) to the individual's clothing, arm or leg, and/or the like. With base unit 102 being so proximate to the individual, cables 106 may be correspondingly short. In some embodiments, cables 106 are less than 50 cm in length. In some embodiments, cables 106 are less than 30 cm in length.

[0045] In the illustrated embodiment, ECG waveforms 110 generated by ECG system 100 are displayed on a display 120. In some embodiments, display 120 may be integral with base unit 102. However, in the illustrated embodiment, display 120 is removably attached to base unit 102 at cradle 122, so that display 120 can be separated from base unit 102 to a location 105 away from the individual's body to permit easy reading by medical professionals without requiring the medical professionals to lean over top of or otherwise crowd the individual's body 101. In the illustrated embodiment, ECG waveforms 110 are wirelessly communicated to display 120 when display 120 is detached from base unit 102. When display 120 is located in cradle 122, ECG waveforms 110 may be provided directly (via a suitable complementary connectors 128A, 128B) to display 120—i.e. without wireless communication.

[0046] Base unit 102 may comprise suitably configured hardware and/or software components for processing signals from electrode units 104 and for generating corresponding ECG waveform(s) 110 for display on display 120. In the illustrated embodiment, such components include: a controller 112, signal processing hardware 114, data storage 116, communications hardware 130 and user interface components 132. For simplicity, only a number of components germane to the present invention are described in detail here. It will be appreciated by those skilled in the art that base unit 102 may comprise other electronic components suitable for operation as described herein. These components may be configured to provide particular functionality using suitably coded software (not explicitly shown). Controller 112 may interact with and control the other functional components of ECG system 100. By way of non-limiting example, controller 112 may comprise any suitable controller, such as, for example, a suitably configured computer, microprocessor, microcontroller, field-programmable gate array (FPGA), other type of programmable logic device, pluralities of the foregoing, combinations of the foregoing, and/or the like. Controller 112 may have access to software which may be stored in computer-readable memory (not shown) accessible to controller 112 and/or in computer-readable memory that is integral to controller 112. Controller 112 may be configured to read and execute such software instructions and, when executed by controller 112, such software may cause controller 112 to implement one or more of the methods described herein.

[0047] Signal processing hardware 114 may comprise any suitable analog or digital signal conditioning and/or signal processing components for generating ECG waveforms 110 from the signals obtained from electrode units 104. By way of non-limiting example, signal processing hardware 114 may comprise amplifiers, buffers, filters, analog to digital converters, suitably configured digital signal processors and/or the like. Data storage 116 may comprise any suitable memory

(e.g. solid state memory) that may be used to store digital ECG data. In some embodiments, data storage 116 may be integrated into other components (e.g. controller 112 or signal processing hardware 114). In some embodiments, data storage 116 is not necessary.

**[0048]** Communications hardware 130 may comprise suitable hardware (e.g. WAN interfaces, LAN interfaces) for wireless communication according to one or more wireless digital communications protocols. Non-limiting examples of such protocols, include: a suitable Bluetooth communication protocol; wireless USB protocol; 802.11 wireless protocol; Zigbee protocol and/or the like. In some embodiments, display 120 may not be detachable from base unit 102 in which case display 120 may be connected via suitable electrical contacts. In some embodiments, display 120 may be removable from cradle 122, but attached to base unit 102 with a signal communication cable or the like. In such embodiments, some or all of communications hardware 130 may not be required. In some embodiments, communications hardware 130 may facilitate communication of ECG data (e.g. data stored in data storage 116, real time ECG waveforms 110 and/or the like) from base unit 102 to an external ECG system 124. In some embodiments, where external ECG system 124 is not capable of wireless communications or of wireless digital communications, ECG system 100 may comprise a suitable external ECG system communications component 124A which may be used to communicate with communications hardware 130 and to convert any received data/signals from communications hardware into a format capable of being interpreted by external ECG system 124. External ECG system communications component 124A may comprise hardware similar to any of the hardware described herein for base unit 102.

**[0049]** In some embodiments, communications hardware 130 may facilitate communication of ECG data (e.g. data stored in data storage 116, real time ECG waveforms 110 and/or the like) from base unit 102 to another device 126A (e.g. a computer or the like) via a network 126 or via a direct communication link (not shown) for further processing and/or display. By way of non-limiting example, network 126 may comprise: a local area network (LAN), such as a hospital network, a work place network or the like; or a wide area network (WAN), such as the internet, a cellular network or the like). In some embodiments, communications hardware 130 may additionally or alternatively facilitate wired communication with external ECG system 124 or with another device 126A (e.g. a computer or the like) via a network 126.

**[0050]** Display 120 together with user interface inputs 130 may be used (by controller 112) to implement a text-based or graphical user interface (UI). User interface inputs 130 may comprise any suitable pointing device, buttons, touch screen and/or the like through which an individual (e.g. a medical professional) can interact with and control ECG system 100. By way of non-limiting example, a medical professional could control such a user interface to: freeze ECG waveform 110 on display 120; view historical waveforms 110 or pulses; switch between the waveforms 110 of different leads; toggle between views of single ECG waveforms 110 or multiple ECG waveforms 110; zoom in on ECG waveform 110 on display 120; measure characteristics (e.g. amplitude and/or frequency) of ECG waveform 110; communicate with other devices (e.g. external ECG system 124 and/or another device via network 126); print to suitably configured printer device; toggle a “graph-paper” background on display 120; identify

abnormal ECG rhythms; display measurements associated with other diagnostic equipment (explained in more detail below) which may be connected to ECG system 100 (e.g. blood pressure, blood sugar, pulse oximetry (SpO<sub>2</sub>), body temperature and/or the like); display alarms or alerts associated with abnormalities measured by such other diagnostic equipment; provide temporal information (e.g. clocks or stopwatches), alarms and/or alerts; and/or the like.

**[0051]** Base unit 102 may comprise a number of additional connectors 108 for optional connection to additional electrode units 104 (not shown). For example, in the illustrated embodiment, base unit comprises seven additional connectors 108 for connection to seven additional electrode units 104. With a total of ten electrode units 104, ECG system can be configured to provide the so-called “12 lead” ECG functionality. In some embodiments, additional connectors 108 may be used to connect to one or more additional electrode units 104 which may be used to sense other types of electrically-based physiological phenomena (physiological electrical activity), such as electrical activity of the brain (e.g. EEG data), electrical activity associated with skeletal muscles (e.g. EMG data), electrical activity of the eye (e.g. EOG data) and/or the like.

**[0052]** Base unit 102 may also comprise suitable connections 134 for connecting to other medical equipment (not shown). Such connections 134 may be used to accept data from such equipment (e.g. from medical diagnostic equipment). By way of non-limiting example, such medical diagnostic equipment may comprise a blood pressure cuff, a glucometer, a pulse oximetry (SpO<sub>2</sub>) monitor, and end-tidal carbon dioxide (ETCO<sub>2</sub>) monitor, a thermometer and/or the like. Connections 134 may also be used for other medical equipment. In some embodiments, connections 134 may be used to connect to a pair of defibrillator pads or paddles which may be used to deliver defibrillation shock(s) (e.g. pacing defibrillation, cardio version defibrillation and/or automatic external defibrillation) to an individual. In some embodiments, connections 134 may be used to provide other electrically sensitive electrode units, which may be similar to electrode units 104 and may be used to sense heart muscle activity (e.g. ECG data), but may additionally or alternatively be used to sense other types of electrically-based physiological phenomena (physiological electrical activity), such as electrical activity of the brain (e.g. EEG data), electrical activity associated with skeletal muscles (e.g. EMG data), electrical activity of the eye (e.g. EOG data) and/or the like. While not expressly shown, base unit 102 may comprise a separate rechargeable battery which may be used to deliver such defibrillation shock(s).

**[0053]** FIG. 4B schematically illustrates an ECG system 200 according to a particular embodiment. ECG system 200 is similar in many respects to ECG system 100 described above and the same reference numerals are used to refer to features of ECG system 200 that are similar to features of ECG system 100. Like ECG system 100, ECG system 200 comprises a base unit 202 and two or more electrode units 204A, 204B (collectively and individually, electrode units 204). ECG system 200 differs from ECG system 100 principally in that electrode units 204 are integral with base unit 202. Other than being located within base unit 202, electrode units 204 may be substantially similar to electrode units 104 described herein and may comprise any features and/or variations of electrode units 104 described herein.

**[0054]** In the illustrated embodiment, ECG system is shown as having a third electrode unit **104C** which attaches to base unit **202** via cable **106C** and connector **108C** to facilitate operation of ECG system **200** in an Einthoven's triangle configuration. Third electrode unit **104C** may be substantially similar to electrode units **104** described herein and may comprise any features and/or variations of electrode units **104** described herein. In some embodiments, third electrode unit **104C** is not necessary and system **100** may use as few as two electrode units **204**. In some embodiments, a third electrode unit **204** may be provided as an integral part of base unit **202** (i.e. similar to electrode units **204** of the FIG. 4B embodiment). Like ECG system **100**, ECG system **200** comprises connectors **108** for accepting additional electrode units **104** to provide additional leads and corresponding additional views of heart muscle electrical activity.

**[0055]** In some embodiments, electrode units **204** may be detachable from base unit **202**—e.g. to sense electrical activity of the heart at different locations away from base unit **202**. For example, electrode units **204** may be provided in suitable sockets (not expressly shown), so that they can function to sense heart activity within their corresponding sockets. But electrodes **204** may be removed from their sockets, so that they can be connected to base unit **202** by suitable cables and connectors (similar to cables **106** and connectors **108** described above for electrode units **104**). In this manner, electrode units **204** may also be able to sense electrical activity at locations away from base unit **202**.

**[0056]** In other respects, ECG system **200** may be substantially similar to ECG system **100** described herein.

**[0057]** FIG. 4C schematically illustrates an ECG system **300** according to a particular embodiment. ECG system **300** is similar in many respects to ECG systems **100**, **200** described above and the same reference numerals are used to refer to features of ECG system **300** that are similar to features of ECG systems **100**, **200**. Like ECG system **200**, ECG system **300** comprises a base unit **202** and two or more electrode units **204** that are integral with base unit **202**. ECG system **300** differs from ECG systems **100**, **200** described herein in that ECG system comprises a third electrode unit **304C** which is connected to base unit **202** via connector **108C** and extension arm **306C**. Third electrode unit **304C** may be substantially similar to electrode units **104** described herein and may comprise any features and/or variations of electrode units **104** described herein. Third electrode unit **304C** may permit ECG system **300** to operate in an Einthoven's triangle configuration. However, in ECG system **300** of the FIG. 4C embodiment, extension arm **306C** is fabricated from flexible, semi-rigid (e.g. limited elasticity) material that may be deformed by the ECG operator and, once deformed, may retain its shape so that electrode unit **304C** remains in a desired location relative to the individual's body **101** until extension arm **306C** is intentionally reshaped or repositioned by the ECG operator. Suitable materials for extension arm **306C** may include, for example, memory plastic and/or the like. In some embodiments, extension arm **306C** may comprise a casing having the flexible, semi-rigid (e.g. limited elasticity) properties which may in turn house a cable (e.g. similar to cable **106** described herein). It will be appreciated that in some embodiments, any electrode units **104** described as being connected to their respective base units may be connected via flexible, semi-rigid (e.g. inelastic) extension arms similar to extension arm **306C**.

**[0058]** In other respects, ECG system **300** may be substantially similar to ECG systems **100**, **200** described herein.

**[0059]** FIG. 4D schematically illustrates an ECG system **400** according to a particular embodiment. ECG system **400** is similar in many respects to ECG systems **100**, **200**, **300** described above and the same reference numerals are used to refer to features of ECG system **400** that are similar to features of ECG systems **100**, **200**, **300**. ECG system **400** comprises a base unit **402** and two or more electrode assemblies **404A**, **404B**, **404C** (collectively and individually, electrode assemblies **404**). Each electrode assembly **404A**, **404B**, **404C** may comprise a corresponding electrode unit **104A**, **104B**, **104C** which may be similar to electrode units **104** described herein and which may comprise any features and/or variations of electrode units **104** described herein. Each electrode assembly **404A**, **404B**, **404C** may also comprise corresponding signal processing components **406A**, **406B**, **406C** (collectively and individually, signal processing components **406**) and communications components **408A**, **408B**, **408C** (collectively and individually, communications components **408**). Signal processing components **406** may comprise any suitable analog or digital signal components for conditioning and/or processing the signals obtained from electrode units **104**. By way of non-limiting example, signal processing components **408** may comprise amplifiers, buffers, filters, analog to digital converters, suitably configured digital signal processors and/or the like. Communications components **408** may comprise any suitable hardware for analog or digital wireless communication of signals obtained from electrode units **104** (and processed by signal processing components **406**) back to base unit **402**. In this manner, base unit **402** may be positioned at a location **105** away from the individual's body **101**. In some embodiments, electrode assemblies **404** may be electrically connected to one another (e.g. to provide a common ground or reference potential). In some embodiments, electrode assemblies **404** may share some of signal processing components **406** and/or communications components **408**.

**[0060]** Electrode assemblies **404** may be located relative to an individual's body **101** (as discussed in more detail below) to generate signals indicative of electrical activity of the individual's heart at their corresponding locations and may wirelessly communicate these signals back to base unit **402** at a location **105** away from the individual's body **101**. In the illustrated embodiment of FIG. 4D, ECG system **400** is shown as having three electrode assemblies **404A**, **404B**, **404C** which may be used in an Einthoven's triangle configuration. In some embodiments, third electrode assembly **404C** is not necessary and system **400** may use as few as two electrode assemblies **404**. In some embodiments, system **400** may be provided with more than three electrode assemblies **404** to provide additional leads and corresponding additional views of heart muscle electrical activity. In some embodiments, electrode assemblies **404** may comprise suitably configured controllers (not shown) which may control signal processing components **406** and/or communications components **408**.

**[0061]** Communications hardware **430** (and associated software) of ECG system **400** may differ from that of ECG systems **100**, **200**, **300** in that communications components **430** of ECG system **400** may be additionally configured to communicate wirelessly with electrode assemblies **404**. In other respects, ECG system **400** may be substantially similar to ECG systems **100**, **200**, **300** described herein.

[0062] In some embodiments, ECG system 400 is operatively connected to a vehicle's embedded software system such that ECG system 400 can communicate with the vehicle's systems to effect changes in the vehicle's physical parts, such as the brakes, engine, and the like. When a vehicle operator steps into the vehicle (e.g. possibly, but not necessarily before starting the vehicle), a vehicle operator may, in one embodiment, be asked to place one electrode unit 104 and/or one electrode assembly 404 onto the vehicle operator's chest (e.g. via a vehicle restraint (seat belt) and/or the like operating in a current sensing mode, a contact field-sensing mode or a non-contact field-sensing mode, in some embodiments) and one or more electrode units 104 and/or electrode assemblies 404 embedded in the back of the vehicle operator's seat (operating in a non-contact field sensing mode, in some embodiments). It will be appreciated that, in some embodiments, additional or alternative locations of electrode units 104 and/or electrode assemblies 404 could be used and that such electrode units (depending on their locations) could operate in current-sensing mode, field-sensing contact mode or field sensing non-contact mode. In some embodiments, electrode assemblies 404 operating only in field sensing non-contact mode are used in the vehicle and the vehicle operator will not need to physically attach electrode units 104 and/or electrode assembly 404 to the operator's chest. Signals detected by electrode units 104 and/or electrode assemblies 404 may be used to generate corresponding ECG signals (e.g. ECG waveforms 110), which may be analyzed (e.g. by controller 112, other controllers in ECG system 400, or external ECG systems 124 (communicating with ECG system 400 through communications component 124A)) to determine the state of the vehicle operator's heart and the vehicle operator's respiration patterns. The analysis may be done through the use of software algorithms and may include comparison to other data sets. Where the ECG waveforms 110 indicate the individual is incapacitated or is not in the proper condition to operate the vehicle, controller 112 communicates with the vehicle's on board system, which may act in accordance with instructions from controller 112. In some embodiment, if the ECG waveform 110 indicates that the vehicle operator is going to fall asleep, is drowsy, or is already asleep, controller 112 may communicate an alarm instruction to the vehicle system, and the vehicle system, upon receiving the instruction, will sound an alarm inside the vehicle or increase the volume of the radio and/or music playing in the entertainment system to wake the vehicle operator. In some embodiments, the alarm may comprise a vibration of the operator's seat to wake the vehicle operator. In some embodiments, the vehicle's infotainment system may ask the vehicle operator questions or require the vehicle operator to issue commands in order to wake, keep awake or otherwise maintain the alertness of the vehicle operator. In some embodiments, if the ECG waveform 110 indicates that the vehicle operator is incapacitated, controller 112 will not permit the vehicle to start or will communicate a stop instruction to the vehicle's system, and the vehicle's system will turn on the vehicle's emergency stop lights and slowly brake the vehicle to a stop. In some embodiments, ECG system 400 may interface or communicate with a vehicle's safety systems, such as active cruise control system, lane departure warning system, frontal collision warning system, precrash system, collision mitigating system, collision avoidance system, and/or the like to reduce the likelihood of an accident's occurrence while the vehicle operator is incapacitated or otherwise unable to oper-

ate the vehicle. ECG system 400 may also communicate the vehicle operator's location and condition to emergency dispatchers such that emergency personnel can attend to the vehicle's vehicle operator quickly. Data from such vehicular ECG systems may be recorded—e.g. for forensic analysis, data analytics and/or the like. Systems 100, 200 and/or 300 and/or any of the EEG, EOG or EMG systems described herein could be used in vehicle in a similar way to system 400 described herein.

[0063] FIG. 5A is a block diagram showing one implementation of a signal processing system 500A for processing data from electrode units 104 according to a particular embodiment. Signal processing system 500A may provide some of signal processing hardware 114 used with any of the ECG systems (e.g. ECG systems 100, 200, 300, 400) described herein. In some implementations, various portions of signal processing system 500A (e.g. amplifiers 504, ADCs 506 and or the like) could be implemented as parts of electrode units 104 (as opposed to being implemented as parts of base units 102, 202, 302, 402). In general, it will be appreciated that the components shown in the FIG. 5A schematic illustration are functional components which could be implemented by various forms of suitably configured hardware.

[0064] Signal processing system 500A receives analog data from electrode units 104. Each electrode unit 104 generates a corresponding analog signal 502 which is amplified by a corresponding amplifier 504 and digitized by a corresponding analog-to-digital converter (ADC) 506 before being provided (as a digital signal 508) to digital signal processor (DSP) 510. In some embodiments, DSP 510 may include integral ADC converters 506. DSP 510 may be configured to generate leads from digital signals 508 and to generate corresponding ECG data (e.g. ECG waveform 110). Digital signal processor 510 may additionally be configured to filter the various digital signals 508 (and/or combinations of such signals). For example, DSP 510 may be configured to filter various signals (or combinations of signals) to remove or mitigate the effects of breathing and/or other sources of artifacts. DSP 510 may additionally or alternatively function to apply active noise cancellation algorithms, based on inverted ambient noise data. DSP 510 may additionally or alternatively scale signals 508 received from electrode units 104 operating in different modes (explained in more detail below). DSP 510 may additionally or alternatively provide synchronization functionality by introducing time delays to one or more of signals 508. Such time delays may be determined based on temporal correlation functions as between signals 508 and/or based on feature (e.g. edges, peaks and/or the like) detection within signals 508. DSP 510 may also combine the various signals 508 to generate leads and corresponding ECG waveforms.

[0065] As is known in the art of digital signal processing, DSP 510 may be configured to process signals using functionality such as sample and hold functions, data acquisition functions, multi stage filtering and bandwidth limiting, filtering based, for example, on a rolling window, averaging functions, peak detection, temporal alignment of signals provided by different electrode units 104, positive and negative edge detection, time duration of PQRST portion of the ECG signal and relationship between them. Digital signal processor 510 may be controlled by controller 112. In some embodiments, however, DSP 510 and controller 112 may be implemented by the same hardware. In the FIG. 5A embodiment, DSP 510 has access to data storage 116. In some embodiments, all or part of data storage 116 may be integral to DSP 510. DSP 510 may

output ECG data to data storage **116** and/or to display **120** (via communications components **130**) and may provide the background functionality for such outputs. As discussed above, in some embodiments when display **120** is located in cradle **122** or when display is integral with base unit **102**, ECG data may be provided directly to display **120** without involving communications hardware **130**.

**[0066]** FIG. 5B is a block diagram showing one implementation of a signal processing system **500B** for processing data from electrode units **104** according to another particular embodiment. Signal processing system **500B** may provide some of signal processing hardware **114** used with any of the ECG systems (e.g. ECG systems **100**, **200**, **300**, **400**) described herein. Signal processing system **500B** receives analog data from electrode units **104**. Each electrode unit **104** generates a corresponding analog signal **502** which is received at analog signal conditioning block **512**. Analog signal conditioning block **512** comprises various amplifiers (e.g. summing amplifiers and/or differential amplifiers and/or inverting amplifiers) which combine analog signals **502** in various ways known in the art to generate leads **514**. Each lead **514** is then amplified by a corresponding amplifier **516** and digitized by a corresponding analog-to-digital converter (ADC) **518** before being provided (as a digital lead signal **520**) to digital signal processor (DSP) **522**. Digital signal processor **522** may then be configured to use digital lead signals **520** to generate corresponding ECG data (e.g. ECG waveform **110**). Other than for receiving leads (as opposed to signals from electrode units **104**), DSP **522** may comprise and provide functionality similar to that described above for DSP **510**. In some embodiments, signal processing system **500B** may be used to generate data from other types of electrically-based physiological phenomena (physiological electrical activity), such as electrical activity of the brain (e.g. EEG data), electrical activity associated with skeletal muscles (e.g. EMG data), electrical activity of the eye (e.g. EOG data) and/or the like.

**[0067]** A description of electrode units is now provided. For the sake of brevity, the description of electrode units refers to electrode units **104**, it being understood that electrode units **204**, **304** may have similar features. For the sake of brevity, the bulk of the description of electrode units **104** assumes that electrode units **104** are used to measure the electrical activity of the heart muscle (e.g. ECG data). However, as mentioned above and discussed in more detail below, electrode units **104** may additionally or alternatively be used to sense other types of electrically-based physiological phenomena (physiological electrical activity), such as electrical activity of the brain (e.g. EEG data), electrical activity associated with skeletal muscles (e.g. EMG data), electrical activity of the eye (e.g. EOG data) and/or the like. In some embodiments, one or more of electrode units **104** comprise resistive sensor elements for sensing the current through or voltage across the resistive sensor element. Electrode units **104** which comprise resistive sensor elements may be referred to herein as current-sensing electrode units (without loss of generality that the voltage across resistive sensor elements could be detected). Current sensing electrode units **104** operate by placing the resistive sensor element in direct contact with a person's skin. In some embodiments, one or more of electrode units **104** comprise capacitive sensor elements which detect the presence of electric field. Electrode units **104** which comprise capacitive sensor elements may be referred to herein as field-sensing electrode units. Unlike resistive sensor elements, the capacitive

sensor elements of field-sensing electrode units **104** do not require direct contact with the skin and may function by being placed close to the person's body (e.g. overtop of clothes, clothing accessories, equipment (including sports and soldier equipment) and/or the like), in (including embedded or mounted within) the backrest or bottom portion of a seat or chair (e.g., seats (e.g. operator seat(s) and/or other seat(s)) or seat restraints (e.g. seat restraints, such as a seat belt, safety belt, and/or the like) in a vehicle such as a car, plane, helicopter, motorcycle, truck, boat, cart, or the like, car seats, strollers, and/or the like), in the controls of a vehicle (e.g., in the handle bars of a motorcycle, in the steering wheel of a car, and/or the like), in a bed (e.g. a hospital bed, crib, bed frame, and/or the like), and/or the like. In some embodiments, electrode units **104** are incorporated into emergency response vehicles, such as police cars, ambulance, fire engines, and/or the like, and military vehicles, such as tanks, armored vehicles, infantry vehicles, amphibious vehicles, trooper carriers, engineering vehicles, military aircraft and/or the like. As discussed in more detail below, field-sensing electrode units may operate in a contact mode (i.e. in direct contact with a person's skin) or a non-contact mode (i.e. not in direct contact with a person's skin).

**[0068]** ECG systems **100**, **200**, **300**, **400** described herein may use either (or both) of current-sensing electrode units **104** and field-sensing electrode units **104**. Each of connectors **108** may be capable of accepting either current-sensing electrode units **104** or field-sensing electrode units **104**. In particular embodiments, a combination of current-sensing electrode units **104** and field-sensing electrode units **104** may be used in any of ECG systems **100**, **200**, **300**, **400** to monitor the heart muscle electrical activity of an individual. The choice of which particular electrode unit **104** may depend on the preferences of the system's operator, the electrode units that are currently available, and the circumstances (e.g. whether it is difficult to remove the individual's clothing, or whether the individual already has exposed skin at the desired vantage points).

**[0069]** In particular embodiments, one or more of electrode units **104** that is used in systems **100**, **200**, **300**, **400** may comprise a multi-mode electrode unit **104** which can be configured to operate in one of a plurality of different modes. Such multi-mode electrode units **104** may operate as current-sensing electrode units by providing a resistive sensor element placed in direct contact with an individual's skin (i.e. under the individual's clothing (or at least with no intervening clothing between the sensor and the individual's skin)). Such multi-mode electrode units **104** may also operate as field-sensing electrode units which involve placing a capacitive sensor element in direct contact with an individual's skin (i.e. under the individual's clothing (or at least with no intervening clothing between the sensor and the individual's skin)). When such field-sensing electrode units are placed in direct contact with an individual's skin (i.e. under the individual's clothing (or at least with no intervening clothing between the sensor and the individual's skin)), such electrode units may be referred to herein as operating in "contact" mode. Such multi-mode electrode units **104** may also operate as field-sensing electrode units which involve placing a capacitive sensor element on top of the individual's clothing and not directly against the skin. When the individual's clothing is located between the electrode unit and the individual's skin, the electrode unit may be referred to herein as operating in "non-contact" mode. Since current-sensing electrode units typi-

cally require direct contact with the skin (i.e. no intervening clothing) to detect a signal, it is not necessary to describe current-sensing electrode units as operating in contact mode or non-contact mode, it being understood that when a current-sensing electrode unit 104 is operative, it operates in contact mode.

[0070] FIGS. 6A and 6B show a multi-mode electrode unit 600, which may be used for electrode unit 104 of any of ECG systems 100, 200, 300, 400. Multi-mode electrode unit 600 may be configured for operation in field-sensing contact mode, field-sensing non-contact mode and/or current-sensing mode. Any one or more of electrode units 104, 204, 304 may comprise an electrode unit 600 of the type shown in FIGS. 6A and 6B. Electrode unit 600 comprises a clamp portion 602 and a sensor portion 604 which is removably attached to clamp portion 602. As discussed in more detail below, sensor portion 604 comprises a capacitive sensor element 606 which permits electrode unit 600 to operate in a field-sensing contact mode (where sensor portion 604 is in direct contact with the individual's skin) or a field-sensing non-contact mode (where sensor portion 604 is located outside of the individual's clothing or otherwise is not in contact with the individual's skin). Further, at least one of clamp portion 602 and sensor portion 604 comprise a mechanism for electrical connection with a resistive sensor element 608 (FIG. 6B) which permits electrode unit 600 to operate in a current-sensing mode. Because electrode unit 600 can be placed either on skin or atop clothing and because electrode unit 600 can operate as a current-sensing electrode unit or a field-sensing electrode unit, electrode unit 600 is versatile and can be used in a range of different situations. For example, in some situations it may be desirable or more convenient to leave the clothing on an individual and to place the electrode unit 600 on top of the individual's clothing. In other situations the individual's skin may be exposed at desired vantage points—for example, the individual's torso may be exposed to allow the performance of a procedure (such as, by way of non-limiting example, defibrillation, CPR, insertion of a chest tube and/or the like) which requires direct contact with or exposure of the skin—and so in those cases it may be convenient to place electrode unit 600 directly against the skin.

[0071] When electrode unit 600 operates in a field-sensing, non-contact mode, electrode unit 600 is placed over the individual's clothing. As seen in FIGS. 6A and 6B, electrode unit 600 comprises a clamp 610. In the illustrated embodiment of FIGS. 6A and 6B, clamp 610 comprises a pair of arms 610A, 610B which are pivotally connected to one another at pivot joint 612 and which are biased toward each other (e.g. by a suitably connected spring, a suitable deformable element and/or the like (not shown)) so that clamp 610 is biased toward a closed configuration. Arms 610A, 610B can be used to grip a part of the individual's clothing to attach the electrode unit 600 to the individual's clothing at the desired vantage point while the electrode unit 600 is being operated in field-sensing, non-contact mode. More particularly, when electrode unit 600 is operated in field-sensing, non-contact mode, a portion of the individual's clothing may be grasped between arms 601A, 601B of clamp 610 and proximate surface 614 of sensor portion 604 may be positioned directly atop the individual's clothing. This permits capacitive sensor element 606 to sense the electric field associated with the individual's heart-muscle activity and to provide a corresponding signal on one or more conductors of cable 624 which may be conveyed back to the base unit of the ECG

system. Cable 624 may comprise one of cables 106 described above (see FIG. 4A, for example).

[0072] In some embodiments, sensor portion 604 is removably attached to clamp portion 602, so that sensor portion 604 may optionally be detached from clamp portion 602 (FIG. 6B)—e.g. for use of sensor portion 604 in field-sensing, contact mode. More particularly, as can be seen by comparing FIGS. 6A and 6B, sensor portion 604 may be attached to clamp portion 602 (e.g. retained in cavity 618 in the particular case of the illustrated embodiment) to provide a unitary electrode unit 600 and sensor portion 604 may also be detached from clamp portion 602 to provide sensor portion 604 separately. When sensor portion 604 is separated from clamp portion 602, the proximate surface 614 of sensor portion 604 may be placed into contact with an individual's skin to permit capacitive sensor element 606 to sense the electric field associated with the individual's heart-muscle activity in a contact mode and to provide a corresponding signal on one or more of the conductors of cable 624 which is conveyed back to the base unit of the ECG system.

[0073] It is not necessary that sensor portion 604 be removed from clamp portion 602 for operation of electrode unit 600 in field-sensing, contact mode. In some embodiments, electrode unit 600 (including clamp portion 602 and sensor portion 604) may be located such that proximate surface 614 of sensor portion 604 is adjacent the individual's skin. For example, as shown in FIG. 6B, cavity 618 (in which sensor portion 604 is retained) comprises a rim 618A around its peripheral edge, but rim 618A defines an opening 619 which permits proximate surface 614 of sensor portion 604 to directly contact an individual's skin. With this configuration, capacitive sensor element 606 is able to sense the electric field associated with the individual's heart-muscle electrical activity in a field-sensing, contact mode (and to provide a corresponding signal to the ECG base unit on cable 624) even when sensor portion 604 is attached to clamp portion 602. Similarly, it is not necessary to operate in a field-sensing contact mode when sensor portion 604 is separated from clamp portion 602. When sensor portion 604 is separated from clamp portion 602, it is still possible to use sensor portion 604 in a field-sensing non-contact mode.

[0074] Sensor portion 604 and/or clamp portion 602 may comprise a locking mechanism 616 for keeping sensor portion 604 attached to clamp portion 602. In the FIG. 6A, 6B embodiment, sensor portion 604 is received in cavity 618 of clamp portion 602 and a spring-biased locking mechanism 616 extends (radially inwardly in the case of the illustrated embodiment) over an edge of distal surface 620 of sensor portion 604. When spring-biased locking mechanism 616 extends over the edge of distal surface 620 of sensor portion, locking mechanism 616 holds sensor portion 604 in cavity 618 (e.g. against rim 618A) and thereby locks sensor portion 604 into attachment with clamp portion 602. To detach sensor portion 604 from clamp portion 602, an operator may slide locking mechanism 616 against the spring bias (radially outwardly in the case of the illustrated embodiment) to remove sensor portion 604 from cavity 618. Some embodiments may comprise a plurality of spring-biased locking mechanisms 616. In some embodiments, sensor portion 604 may be locked to clamp portion 602 using different additional or alternative locking mechanisms. In the illustrated embodiment, when sensor portion 602 is located in cavity 618, cable 624 which is attached to sensor portion 604 runs through a channel 611 formed in a sidewall of cavity 618 of clamp portion 602. In

other embodiments, cable 624 may run through different features when sensor portion 604 is attached to clamp portion 602.

[0075] In some embodiments, when electrode unit 600 is being used in field-sensing, contact mode, electrode unit 600 (or sensor portion 604 of electrode unit 600) may be adhered to the skin of the individual using adhesive tape, adhesive stickers, a suctioning mechanism or other means. For example, a double-sided adhesive sticker or tape can be placed between the individual's skin and electrode unit 600 (or sensor portion 604 of electrode unit 600) to adhesively connect electrode unit 600 (or sensor portion 604 of electrode unit 600) to the individual's skin. Similarly, adhesive tape can be applied over top of electrode unit 600 to tape electrode unit 600 in contact with an individual's skin and to permit electrode unit 600 to be used in field-sensing contact mode. In some embodiments, electrode unit 600 (or sensor portion 604 of electrode unit 600) may comprise a suction cup or suction hole (not shown) fluidly coupled to a suctioning bulb (not shown). The bulb may be squeezed prior to placement of the suction cup/hole on the individual's skin. Once the suction cup/hole is placed on the skin, the bulb is released to create a suctioning connection between the suction cup/hole and the skin, thereby holding electrode unit 600 (or sensor portion 604 of electrode unit 600) against the individual's skin. In some embodiment, a piece of tape may be applied to the individual's skin with an end portion of the tape extending away from the individual's skin. The end portion of the tape may then be adhered to a side surface 615 of sensor portion 604 or the end portion of the tape may be gripped between arms 610A, 610B of clamp 610 to help hold electrode unit 600 (or sensor portion 604 of electrode unit 600) against the individual's skin to thereby facilitate operation in field-sensing contact mode.

[0076] In addition to operating in field-sensing non-contact mode and field-sensing contact mode as discussed above, electrode unit 600 also operates in current-sensing mode. More particularly, at least one of clamp portion 602 and sensor portion 604 comprise a mechanism for electrical connection with a resistive sensor element 608 (FIG. 6B) which permits electrode unit 600 to operate in a current-sensing mode. In the illustrated embodiment, sensor portion 604 of electrode unit 600 comprises a snap-mechanism 622 for connection to a complementary snap-mechanism 626 on resistive sensor element 608. In the illustrated embodiment, snap-mechanism 622 is located on distal surface 620 of sensor portion 604. In other embodiments, snap mechanism 622 may be located on other surface(s) of sensor portion 604 and/or clamp portion 602. Snap mechanism 622 is in electrical contact with one or more conductors in cable 624 so that a signal may be conveyed back to the base unit of the ECG system via cable 624. The cable 624 conductor that is in electrical contact with snap mechanism 622 may be (but need not be) the same cable 624 conductor that is in electrical contact with the capacitive sensor element 606.

[0077] FIG. 7A shows a variety of resistive sensor elements 608A, 608B, 608C (collectively and individually, resistive sensor elements 608) of different shapes and sizes, each with a corresponding snap-mechanism 626A, 626B, 626C (collectively and individually, snap-mechanisms 626). In the current North American industry standard, snap-mechanisms 626 of resistive sensor elements are male snap-mechanisms 626. Accordingly, snap-mechanism 622 of electrode unit 600 may comprise a female snap-mechanism sized and shaped to mate

with male snap-mechanisms 626 of resistive sensor elements 608. Snap-mechanisms 622, 626 are complimentary to one another, so that when they are engaged, there is a small amount of deformation of one or both of snap-mechanisms 622, 626 such that restorative forces associated with that deformation tend to lock snap-mechanisms 622, 626 to one another.

[0078] In use, a resistive sensor element 608 is connected to electrode unit 600 via a connection of snap-mechanisms 622, 626 and then the side of resistive sensor element 608 opposite snap-mechanism 626 is adhered to the skin of the individual for operative in current-sensing contact mode. Typically, resistive sensor elements 608 comprise an adhesive "peel and stick" type backing which may be used for this purpose. The heart muscle electrical activity signal detected by resistive sensor element 608 is conveyed via the contact between snap-mechanism 622, 626 to cable 624 and to the base unit of the ECG system. When operating in current-sensing mode, sensor portion 604 of electrode unit 600 may be removed from clamp portion 602 of electrode unit 600 in the same manner discussed above. This is not necessary, however, and electrode unit 600 may operate in current-sensing mode with sensor portion 604 connected to clamp portion 602.

[0079] Resistive sensor elements 608 having snap-mechanisms 626 are common, but are not the only type of resistive sensor element. FIG. 7B depicts another type of resistive sensor element 630 which comprises an active surface 632 which may be adhered to the individual's skin (e.g. with a peel and stick type adhesive or a suitable external adhesive). Resistive sensor element 603 also comprises a tab 634, such that when active surface 632 is adhered to the individual's skin, tab 634 may be bent (or may otherwise extend) away from the individual's body. Multimode electrode unit 600 may also function in a current-sensing contact mode with resistive sensor elements 630. More particularly, tab 634 of resistive sensor element may be clamped between the arms 610A, 610B of clamp 610. One or both of the engagement surfaces of clamp 610 may be provided with electrical contacts 636A, 636B (collectively and individually, clamp contacts 636). Clamp contacts 636 may be electrically connected to transmit a current-sensing contact signal through electrode unit 600 and a conductor of cable 624 back to the base unit of the ECG system.

[0080] In the case of the illustrated embodiment, clamp contacts 636 are in electrical contact with electrical contact 638 (e.g. via a suitable wire or other conductor within one or both arms 610A, 610B of clamp 610. Electrical contact 638 may comprise any suitable electrical contact pin, plate, socket, shoe and/or the like. In the illustrated embodiment, electrical contact 638 is located on a wall of cavity 618. Sensor portion 604 may be provided with a complementary electrical contact (not shown in the illustrated view) which is in electrical contact with one of the conductors of cable 624. The electrical contact in sensor portion 604 may be complementary to electrical contact 638 and may comprise any suitable electrical contact pin, plate, socket, shoe and/or the like. In some embodiments, one or both of contact 638 and the contact in sensor portion 604 may be spring-loaded. When sensor portion 604 is connected to clamp portion 602 (e.g. sensor portion 604 is located in cavity 618 as shown in FIG. 6A of the illustrated embodiment), the electrical contact shoe of sensor portion 604 makes electrical contact with electrical contact shoe 638 of clamp portion 602, thus completing an electrical contact from clamp contacts 636, through electrical

contact shoe 638 of clamp portion 602 and the electrical contact shoe of sensor portion 604 to a conductor of cable 624 and back to the base unit of the ECG system. In this manner, electrode unit 600 may work in current-sensing contact mode with resistive sensor element 630 and may convey heart activity signals back to the base unit of the ECG system.

[0081] In electrode unit 600 of the FIG. 6A, 6B embodiment, clamp 610 serves two functions. As described above, clamp 610 can be used to attach (e.g. electrically and physically couple) to a current-sensing element 630 so that electrode unit 600 can be operated in a current-sensing mode. Alternately, clamp 610 can be used to attach electrode unit 600 to clothing when the electrode unit 600 is being operated in a field-sensing non-contact mode. In other embodiments a separate clamping structure may be provided for each of these functions.

[0082] In the illustrated embodiment of FIGS. 6A and 6B, sensor portion 604 is connected to clamp portion 602 at a location between arms 610A, 610B of clamp portion 602. This is not necessary. In some embodiments, sensor portion 604 may be connected to other locations on clamp portion 602. By way of non-limiting example, sensor portion 604 may be connected to an outside of one of arms 610A, 610B of clamp portion 602 or within one of arms 610A, 610B of clamp portion 602—i.e. such that sensor portion 604 is not located between arms 610A, 610B. In the illustrated embodiment, sensor element 606 is generally round in cross-section. In other embodiments, sensor element 606 may have a keyed-shape (e.g. a protrusion from its sidewall 615 (or one of its sidewalls) and a corresponding groove in the sidewall of cavity 618 or vice versa) or some other cross-sectional shape. In some embodiments, sidewall of cavity 618 may have a socket shaped to fit sensor element 606. This may help to ensure alignment between electrical contact shoe 638 and the complementary electrical contact shoe on sensor portion 604.

[0083] In the description of FIGS. 6A and 6B above, signals from resistive sensor elements 608, 630 and from capacitive sensor elements 606 are conveyed back to the base unit of the ECG system via cable 624. Cable 624 may comprise one of cables 106 described above. Cable 624 may be connected to the base unit using a corresponding connector 108 (see FIG. 4A, for example). Connectors 108 may comprise multi-conductor (e.g. multi-pin) connectors. Such conductors/pins may comprise, without limitation: a ground pin; one or more current-sensing signal pins (e.g. one pin connected to snap-mechanism 622, one pin connected clamp contacts 636 or one pin connected to both snap-mechanism 622 and clamp contacts 636); and one or more field-sensing signal pins (e.g. connected to field-sensing element 606). In some embodiments, signals from both field-sensing element 606, snap mechanism 622 and clamp contacts 636 may be connected to the same pin of connectors 108. Cable 624 and connectors 108 may comprise additional pins for conveying additional information from electrode unit 600. For example, cable 624 may comprise conductors and connectors 108 may comprise pins for signals from proximity sensor(s) which may assist with determining the operational mode electrode unit 600, as explained below. As discussed above in FIG. 4D, electrode unit 600 may be provided as part of an electrode assembly 404 where signals are wirelessly conveyed from electrode assemblies 404 to the base unit of the ECG system. In such embodiments, cable 624 may be considered to be a suitable electrical contact to signal processing components 406 of electrode assembly 404—see FIG. 4D.

[0084] Where electrode units 104 of ECG systems 100, 200, 300, 400 are provided by multi-mode electrode units 600, an ECG system 100, 200, 300, 400 may be operated with its electrode units 600 operating in different modes. By way of non-limiting example, electrode units 104A, 104B may operate in any desired combination or permutation of: field-sensing non-contact mode (e.g. over clothing), field-sensing contact mode (i.e. directly against the individual's skin) and current-sensing mode. Similarly, each of electrode unit 104C and any additional electrode units connected to connectors 108 may operate in any desired one of: field-sensing non-contact mode, field-sensing contact mode and current-sensing mode.

[0085] The operation of electrode units 104 in different operational modes within a particular ECG system 100, 200, 300, 400 may yield corresponding electrical signals 502 (see FIGS. 5A, 5B) having different amplitudes. For example, an electrode unit 104 operating in current-sensing mode typically provides a signal 502 which is several orders of magnitude larger than an electrode unit 104 operating in field-sensing mode. Similarly, an electrode unit 104 operating in a field-sensing contact mode may yield a slightly stronger (e.g. 10%-50% stronger) signal 502 than an electrode unit 104 operating in field-sensing non-contact mode. Signals 502 having different amplitudes can be scaled or the like (e.g. by signal processing hardware 114) to normalize the signals prior to determining ECG leads (or other combined or differential signals). Suitable scaling factors can be pre-determined parameters, user-configurable parameters, system-configurable parameters or determined on an ad hoc basis. In one non-limiting example, digital signal processor 510 (FIG. 5A) may be configured to determine the amplitude (e.g. the maximum and minimum level) of each signal from each electrode unit 104 and to use this information to scale the signals from the various electrodes to normalize the signals to have at least approximately the same amplitude. In another non-limiting example, an amplifier or automatic gain control circuit (AGC) in analog signal conditioning circuitry 512 (FIG. 5B) may scale signals from electrode units operating in different modes by suitable pre-determined and/or configurable factor (s) in effort to normalize the signals from electrode units operating in different modes. In some embodiments, scaling may be non-linear.

[0086] In some circumstances, it may be desirable to determine the operational modes of electrode units 104 so that appropriate adjustments can be made to their corresponding signals before generating ECG leads (or other combined or differential signals). For example, where one electrode unit 104 is being operated in a field-sensing mode and another electrode unit 104 is being operated in a current-sensing mode, it may be desirable to scale the signals to have the same order of magnitude.

[0087] As discussed above with reference to FIGS. 6A and 6B, in some embodiments, signals from different operational modes of electrode unit 600 can be conveyed on different conductors of cable 624 and conveyed to the base unit of an ECG system through a different pin of connector 108. In this manner, the ECG system may be able to tell the operational mode of each of its electrode units 104. In some embodiments, an operator may additionally or alternatively provide information to the ECG system (e.g. via user inputs 132) to allow the ECG system to determine which electrode unit 104 is operating in which operational mode. In some embodiments, the strength of the signal from each electrode unit 104

may additionally or alternatively be used by the ECG system to determine the operational mode of each electrode unit **104**. For example, a signal having an amplitude above a certain threshold may be indicative of a current-sending mode of operation.

[0088] In some embodiments, one or more additional sensors (not expressly shown) can additionally or alternatively be incorporated into electrode units **104** to assist with determining the mode of operation. For example, one or more first proximity sensors can be located in electrode unit **104** to detect a presence of a resistive sensor element (e.g. a resistive sensor element **608** connected to snap-mechanism **622** or a resistive sensor element **630** clamped between arms **610A**, **610B** of clamp **610**). If the one or more first proximity sensors detect a resistive sensor element, then ECG system may conclude that electrode unit **104** is operating in current-sensing mode. One or more second proximity sensors can be located in electrode unit **104** to detect the proximity of the individual's skin. If the one or more second proximity sensors detect that the individual's skin is within a certain threshold distance and the one or more first proximity sensors do not detect a resistive sensor element, then ECG system may conclude that electrode unit **104** is operating in field-sensing contact mode. On the other hand, if the one or more second proximity sensors detect that the individual's skin is outside of the threshold distance and the one or more first proximity sensors do not detect the resistive sensor element, then it may be assumed that the electrode unit **104** is operating in a field-sensing non-contact mode. In some embodiments, the one or more second proximity sensors may be configured to detect the presence of a clamp portion of the electrode unit (explained in more detail below) and may conclude that electrode unit **104** is operating in a field-sensing non-contact mode when the clamp portion is sufficiently proximate or a field-sensing contact mode when the clamp portion is sufficiently far away.

[0089] It will be appreciated that the use of proximity sensors represent just one sensor-based technique for determining the operational mode of an electrode unit **104**. Sensors other than proximity sensors may additionally or alternatively be used to help with the determination of the operational mode of an electrode unit **104**. For example, suitable electrical contact sensors (e.g. micro-switches) and/or the like could be used to detect the presence of resistive sensor elements and/or clothing. For example, suitable proximity sensor, micro-switches, electrical contact sensors or the like could be used to detect whether or not clamp **610** is closed and could thereby be used to determine if a resistive sensor element or clothing was being held in clamp **610**.

[0090] As discussed above, electrode unit **600** comprises a capacitive sensor element **606** which enables electrode unit **600** to operate in a field-sensing mode. FIG. **8** is an exploded cross-sectional view of a capacitive sensor element **606** that may be used with the FIG. **6A**, **6B** electrode unit **600** or an electrode unit **104** according to a particular embodiment. Capacitive sensor element **606** comprises proximate and distal surfaces **614**, **620** corresponding to proximate and distal surfaces **614**, **620** shown in FIG. **6B**. The main sensor of capacitive sensor element **606** comprises an electrodynamic sensor **650** which is sensitive to local electric field. A non-limiting example of a suitable electrodynamic sensor **650** is described, for example, in U.S. Pat. No. 7,885,700. Another

non-limiting example of a suitable electrodynamic sensor **650** is the sensor No. PS25205B marketed by Plessey Semiconductors Ltd. of the UK.

[0091] Capacitive sensor element **606** of the FIG. **8** embodiment comprises a number of components and layers:

[0092] An antenna component **652** which serves as an antenna to increase electromagnetic signal sensitivity of electrodynamic sensor **650** and to improve the signal resolution of electrodynamic sensor **650**. Antenna component **652** of the illustrated embodiment comprises a PCB core **654**. On an inner side of PCB core **654**, antenna component **652** comprise a layer of metallization (e.g. solder plated conductor) **656** which is in direct electrical contact with electrodynamic sensor **650** (described below). On an outer side of PCB core **654**, antenna component **652** comprises a layer of metallization (e.g. solder plated conductor) **658**, which is in turn coated with a thin non-conductive protective (e.g. solder mask) layer **660**. Inner and outer metallization layers **656**, **658** are electrically connected to one another by conductive vias **662** provided at suitable locations. Outer metallization layer **658** may be transversely recessed (e.g. by 1-5 mm) at its transverse edges **568A** to insulate outer metallization layer **658** from sensor housing **659**. Metallization layer **658** (and, possibly metallization layer **656**) may serve as the radiating element of an antenna which is in electrical contact with the sensing surface of electrodynamic sensor **650**. Metallization layer **658** and, possibly metallization layer **656** (i.e. the radiating element of antenna component **652**) may have a surface area that is greater than a surface area of the sensing surface of electrodynamic sensor **650**. In some embodiments, an outer peripheral rim of antenna component **652** could be provided with a stepped profile (e.g. an outer peripheral rim having less thickness in the left-to-right dimension of FIG. **8**) to accommodate the thickness of rim **618A** (see FIG. **6B**).

[0093] A sensor-positioning layer **664** may be used on an inside of antenna layer **652** and may provide a cut-out **666** as shown to ensure the proper placement and/or orientation of electrodynamic sensor **650**. Sensor-positioning layer **664** may comprise a suitable non-conductive PCB material or a single-layer PCB substrate with etched out copper layer.

[0094] A sensor-holding layer **668** which holds electrodynamic sensor **650**. Sensor-holding layer **668** may comprise a sensor-holding PCB. Sensor-holding layer **668** may provide suitable solderable contacts to solder electrodynamic sensor **650** and suitable electrical connections to main PCB layer **672** described below. In some embodiments, sensor-holding layer **668** and main PCB layer **672** may comprise complementary (e.g. male and female) electrical contacts and/or connector components (not shown) that mate when sensor element **606** is assembled.

[0095] An insulator layer **670**, which provides compressive force and facilitates proper electrical contact between the inner metallization layer **656** of antenna layer **652** and electrodynamic sensor **650**. Insulation layer **670** may comprise Ethafoam™ material, for example. Insulator layer **670** may comprise a cut-out section (not shown) which permits electrical connections between sensor-holding layer **668** and main PCB layer **672** (as discussed above).

- [0096]** A main PCB layer **672** which houses the electronic circuitry (e.g. amplifiers, other signal conditioning components and/or the like) for operation of capacitive sensing element **606**. Main PCB layer may provide electrical contact to cable **624** described with reference to FIGS. **6A** and **6B** above.
- [0097]** A distal component **674** serving as distal surface **620**. Distal component **674** may comprise a metallized layer **676** which may provide electrical noise shielding. In the illustrated embodiment, metallization layer **676** is provided on the outside of distal component **674**. Distal component **674** may provide suitable conduits (not shown) for electrical connection to snap mechanism **622**.
- [0098]** A snap-mechanism **622** for connecting to complementary snap mechanism **626** of resistive sensor elements **608**. In the illustrated embodiment, snap-mechanism **622** comprises a female snap mechanism. In other embodiments, however, snap-mechanism **622** could comprise a male snap mechanism. As discussed above, snap-mechanism **622** may be electrically connected to a conductor in cable **624**. Snap-mechanism **622** may be electrically insulated from metallization layer **676** by suitable etching of metallization layer **676** or some other suitable insulating technique.
- [0099]** In some embodiments, electrode unit **104** comprises capacitive sensor element **606** as described herein to enable electrode unit **104** to operate in a field-sensing mode and may be provided with or without components that permit operation in current sensing mode. In some embodiments, electrode assembly **404** comprises one or more electrode units **104** that operate in field-sensing mode and comprises capacitive sensor element **606**. In some embodiments, capacitive sensor elements **606**, individually, or as part of electrode unit **104**, multimode electrode unit **600** or electrode assembly **404** may be incorporated into clothing, such as shirts, pants, shoes, clothing accessories, including watches, hats, belts, headbands, helmets, fitness bands, sports equipment, including, pads (e.g. shoulder, knee, elbow pads, and/or the like), guards, gloves, and the like. In some embodiments, capacitive sensor elements **606** may be embedded (e.g. sewn into, attached to, and/or the like) within clothing, clothing accessories, sports equipment, and the like. Capacitive sensor elements **606**, electrode unit **600**, and/or electrode assembly **404** may also be embedded or incorporated into or contained within seats (e.g. seats (operator seat(s) and/or other seat(s)) in a vehicle such as a car, plane, motorcycle, truck, boat, or the like, car seats, strollers, and/or the like), chairs (e.g. wheel-chairs and/or the like), restraints for the seats and/or chairs (e.g. seat belts, safety belts, and/or the like), the controls of a vehicle (e.g., in the handle bars of a motorcycle, in the steering wheel of a car, and/or the like), beds (e.g. a hospital bed, crib, bed frame, and/or the like), couches, and/or the like, furniture (e.g. tables, sofas, recliners, and/or the like), decorations, furnishings (e.g. cushions, pillows, and/or the like), and other fixtures (e.g. toilet seats, sinks, bath tub, and/or the like). In some embodiments, capacitive sensor elements **606**, electrode unit **600**, and/or electrode assembly **404** may be embedded or incorporated into or contained within emergency response vehicles, such as police cars, ambulance, fire engines, and/or the like, and military vehicles, such as tanks, armored vehicles, infantry vehicles, amphibious vehicles, trooper carriers, engineering vehicles, military aircraft and/or the like. These implementations allow capacitive sensor elements **606**, electrode unit **600**, and/or electrode assembly **404** to operate in field sensing mode and to detect electrical signals from the heart muscle of an individual or other when the individual is wearing clothing and clothing accessories or when the individual is in close proximity to the chairs, beds, couches, furniture, decorations, furnishings, and fixtures. In some embodiments, capacitive sensor elements **606**, electrode unit **600**, and/or electrode assembly **404** may be used to sense other types of electrically-based physiological phenomena (physiological electrical activity), such as electrical activity of the brain (e.g. EEG data), electrical activity associated with skeletal muscles (e.g. EMG data), electrical activity of the eye (e.g. EOG data) and/or the like. In some embodiments, electrode assembly **404** is powered by batteries, including removable or non-removable batteries. In some embodiments, these batteries are charged using a physical connection to a source of electricity. In other embodiments, these batteries are charged wirelessly. In some embodiments, these batteries may be charged by body movement. In some embodiments, these batteries may be charged by body heat. In other embodiments, electrode assemblies **404** may be charged by a combination of any of the foregoing methods.
- [0100]** ECG systems (e.g. systems **100**, **200**, **300**, **400**) according to particular embodiments may include mechanisms for reducing the effects of ambient electrical noise. More particular, ECG systems according to particular embodiments may comprise one or both of a grounding strap (not shown) or a right leg electrode (not shown). Such a grounding strap or right leg electrode may be used in addition to the grounding techniques implemented in electrode units **104** and/or in addition to filtering techniques provided by signal processing components described above to reduce the ambient electrical noise's impact on received electrical heart activity signals. Some sources of ambient noise (e.g. power line hum that could be either 60 Hz or 50 Hz) may be too strong to be effectively filtered by using the signal processing circuitry of the ECG systems. Accordingly, in some embodiments, one or both of a grounding strap or a right leg electrode may be used to increase the signal-to-noise ratio for subsequent signal processing.
- [0101]** A grounding strap may be provided to link the negative side of the power source (e.g. battery (not shown)) of base unit **102** to the individual's skin while limiting the current flow for safety of the individual. Such a grounding strap may be similar to the grounding straps used in electronics laboratories and/or electronic fabrication facilities and may be worn so as to touch the individual's skin to be effective for ambient electrical noise rejection (e.g. common mode rejection of the amplifiers associated with electrode units **104**).
- [0102]** A Right Leg Drive (RLD) electrode may be implemented to inject the "inverted" polarity noise of same amplitude as an ambient electrical noise onto an individual's skin in order to compensate for the common mode noise. The RLD circuitry may comprise an inverting amplifier, a filter and a safety limiting resistor to prevent exceeding the safety limit of the noise signal injected onto the skin. This RLD electrode may or may not touch the skin in order to inject inverted ambient noise into the system. The DSP may use the inverted ambient noise signal from the RLD electrode to at least partially cancel ambient noise and to thereby increase the signal-to-noise ratio. A RLD electrode may be provided with similar physical characteristics as electrode to unit **600** described

above and may comprise a clamp portion similar to clamp portion 602 for attaching to an individual's clothing or the like.

[0103] In some embodiments, ECG systems 100, 200, 300, 400 (FIGS. 4A-4D) are portable and lightweight systems that are convenient to use and transport. For example, they may be compact enough to be carried by hand so that they are easy to transport to an individual's current location, which may be in the individual's home or in some other location. In some embodiments, ECG systems 100, 200, 300, 400 may be designed to be small enough to fit within a carrying bag or pocket.

[0104] FIG. 9 illustrates an ECG system 900 incorporating a harness 901 and a plurality of electrode units 104 according to a particular embodiment. In many respects, ECG system 900 is similar to ECG systems 100, 200, 300, 400 (FIGS. 4A-4D) described above. In the illustrated embodiment of system 900, harness 901 comprises a rigid portion 903 one or more straps 910 that wrap around the body of an individual or are otherwise shaped to fit on or to be worn around the individual's body. In some embodiments, straps 910 are configured to extend from and recoil into rigid components 903, which may be located at the front of the individual's body (as illustrated in FIG. 9) and/or located at the back and/or to the side of the individual's body. Harness 901 and/or straps 910 may comprise components that are connected to each other by fasteners, such as hook and loop, clips, buttons, and/or the like. Electrode units 104 may be similar to electrode units 104 described elsewhere herein and may comprise any feature(s) of and/or modification(s) to electrode units 104. In some embodiments, electrode units 104 may comprise capacitive sensor elements, each having an electrodynamic sensor sensitive to electromagnetic waves and an antenna comprising an electrically conducting radiating element for receiving electromagnetic waves as described elsewhere herein. In some embodiments, electrode units may comprise multi-mode electrode units 600 of the type described herein. In the FIG. 9 embodiment, electrode units 104 are provided as part of electrode assemblies 404 which may be substantially similar to electrode assemblies 404 described elsewhere herein and may comprise any feature(s) of or modification(s) to electrode assemblies 404. Electrode assemblies 404 may be located at locations (e.g. adjustable locations) on harness 901 and/or straps 910 so that when harness 901 is worn by an individual, electrode assemblies 404 will be located in desirable positions relative to the heart—e.g. for detection of suitable ECG data. Electrode assemblies 404 may be integrated into or embedded within harness 901 and/or straps 910 or attached to harness 901 and/or straps 910 by hooks, clips, compression clips, hook and loop systems, and the like. In some embodiments, harness 901 comprises tracks such that electrode assemblies 404 are movable along the tracks to different locations of the person's body. In some embodiments, harness 901 comprises location indicators, such as a coloured indicator, an identification spot, and/or the like, to allow the wearer to position electrode assemblies 404 at the applicable location on the wearer's body. In other embodiments, harness 901 comprises measurement lines, a ruler, and/or the like to allow the wearer to measure distances between locations on harness 901. The location indicators and/or measurement lines may also allow different wearers to adjust the locations of electrode assemblies 404 on harness 901 depending on the wearer's body type and/or body traits. System 900 may comprise controls for operating electrode

assemblies 404, such as controls for switching individual electrode units 104 between field-sensing and current-sensing modes (e.g. where electrode units 104 comprise multi-mode electrode units, such as electrode units 600), on-off switches, and the like. In some embodiments, harness 901 comprises compression clamps, and the compression clamps hold electrode assemblies 404 at appropriate locations on an individual's body. In some embodiments, electrode assembly 404 or electrode unit 104 comprises capacitive sensor element having an electrodynamic sensor sensitive to electromagnetic waves and an antenna comprising an electrically conducting radiating element for receiving electromagnetic waves as described elsewhere herein.

[0105] System 900 may also comprise a base unit 920 which may be similar to base unit 402 of ECG system 400 described above. Base unit 920 may comprise suitable communication hardware (not shown) similar to communication hardware 430 described above, which may facilitate communication between electrode assemblies 404 and external ECG systems or to other devices (not shown) such as a smartphone, tablet, laptop, computers, and/or the like. Communication between electrode units 104 and base unit 920 may be by wire or cable embedded within or attached to harness 901, straps 910, tracks, and/or the like. Communication between electrode units 104 and base unit 920 may additionally or alternatively be wireless according to any suitable wireless communication protocol. Communication between base unit 920 and the external ECG system and/or other devices may be wireless according to any suitable wireless communication protocol. Base unit 920 may comprise connectivity indicators 922 to allow the harness wearer to determine whether reliable communication is established between base unit 920 and the external ECG system and/or other devices. System 900 may also incorporate other sensors or medical devices such as blood pressure cuff, pulse oximeters, glucose monitors, and/or the like, although this is not necessary.

[0106] Electrode units 104 described herein (including electrode units 204, 304, 600 and electrode assemblies 404) are sensitive to electrical characteristics of the body (physiological electrical activity), whether they are current-sensing electrode units, field-sensing electrode units, multi-mode electrode units operating in current-sensing mode or multi-mode electrode units operating in contact or non-contact field-sensing mode. Because of this sensitivity to physiological electrical activity, electrode units 104 may be used to sense physiological electrical activity other than the electrical activity of the heart muscle and can be used as a part of corresponding systems used to generate other types of data based on such physiological electrical activity (e.g. electrical characteristics of other cell(s), tissue(s), organ(s) and/or system(s) in the person's body). By way of non-limiting example, electrode units similar in many respects to electrode units 104 described herein could be used to sense other types of electrically-based physiological phenomena (physiological electrical activity), such as electrical activity of the brain (e.g. as part of an EEG system for generating EEG data), electrical activity associated with skeletal muscles (e.g. as part of an EMG system for generating EMG data), electrical activity of the eye (e.g. as part of an EOG system for generating EOG data) and/or the like. Using such electrode units, ECG systems 100, 200, 300, 400, and/or 900 described herein could be used or suitably modified for use as EEG, EMG and/or EOG systems. Similarly, signal processing systems

**500A, 500B** could be used or suitably modified for use in EEG, EMG and/or EOG systems.

**[0107]** FIG. 10 schematically illustrates an EEG system **1000** according to a particular embodiment. EEG system **1000** of the FIG. 10 embodiment is shown having a general architecture that is similar to ECG system **400** (FIG. 4D) and similar reference numerals are used to refer to features of EEG system **1000** that are similar to corresponding features of ECG system **400**. It will be appreciated by those skilled in the art (given the description of ECG systems **100, 200, 300, 400** above and the description of EEG system **1000** below) that EEG system **1000** could be modified to have the general architecture of any of ECG systems **100, 200, 300, and 400**. EEG system **1000** comprises a base unit **1002** and two or more electrode assemblies **1004A, 1004B, 1004C** (collectively and individually electrode assemblies **1004**). Consistent with the architecture of ECG system **400** (FIG. 4D), each electrode assembly **1004** of the illustrated embodiment of EEG system **1000** comprises a corresponding electrode unit **104A, 104B, 104C** which may be similar to electrode units **104** described herein, but which may be configured for detection of brain activity and corresponding EEG data. By way of non-limiting example, electrode units **104** may comprise multi-mode electrode units similar to multi-mode electrode units **600** described herein. In some embodiments, electrode units **600** comprise capacitive sensor element **606** and the capacitive sensor element **606** comprises antenna component **652** and electrodynamic sensor **650** as described herein. In some embodiments, electrode units **104** may comprise one or more capacitive sensor elements, each having an electrodynamic sensor sensitive to electromagnetic waves and an antenna comprising an electrically conducting radiating element for receiving electromagnetic waves as described elsewhere herein.

**[0108]** Consistent with the architecture of ECG system **400** (FIG. 4D), each electrode assembly **1004** of the illustrated embodiment of EEG system **1000** comprises corresponding signal processing components **1006A, 1006B, 1006C** (collectively and individually signal processing components **1006**) and communications components **1008A, 1008B, 1008C** (collectively and individually communications components **1008**). Signal processing components **1006** and communications components **1008** may be similar to signal processing components **406** and communications components **408** described herein, but may be configured for detection of brain activity and corresponding EEG data. In some embodiments, signal processing components **1006** (and/or signal processing components **114** of base unit **1002**) comprise signal amplifiers with very low noise. The input signals being measured by electrode units **104** in electrode assemblies **1004** of EEG system **1000** may be as low as tens of microvolts peak-to-peak; accordingly, amplifiers having noise levels below this may be desirable. Electrode units **104** and/or electrode assemblies **1004** may detect electrical signals from the brain in current-sensing mode, field-sensing contact mode and/or field sensing non-contact mode. In one embodiment, one electrode unit **104** and/or electrode assembly **1004** detects electrical signals from the brain in current-sensing mode with the other electrode unit **104** and/or electrode assembly **1004** in field-sensing contact mode or field sensing non-contact mode. In other embodiments, electrode units **104** and/or electrode assemblies **1004** may all operate in field-sensing non-contact mode to detect electrical signals from the brain. In some embodiments, electrode units **104** and/or elec-

trode assemblies **1004** may operate in a combination of field-sensing contact mode and field-sensing non-contact mode. In some embodiments, electrode units **104** and/or electrode assemblies **1004** may comprise one or more capacitive electrode sensor elements, each having an electrodynamic sensor sensitive to electromagnetic waves and an antenna comprising an electrically conducting radiating element for receiving electromagnetic waves as described elsewhere herein.

**[0109]** Base unit **1002** may be positioned at a location **105** away from an individual's body **101** and electrode assemblies **1004** may communicate measured signals or data back to base unit **1002**. In some embodiments, electrode assemblies **1004** may be electrically connected to one another (e.g. to provide a common ground or reference potential). In some embodiments, electrode assemblies **1004** may share some of signal processing components **1006** and/or communications components **1008**. In some embodiments, electrode assemblies **1004** may comprise suitably configured controllers (not shown) which may control signal processing components **1006** and/or communications components **1008**. In the embodiment illustrated in FIG. 10, electrode assemblies **1004** communicate wirelessly to base unit **1002**. In some embodiments, one or more than one of electrode assemblies **1004** may be physically connected to base unit **1002** by corresponding cables and may communicate to base unit **1002** through such cables. In some embodiments, electrode assemblies **1004** may be physically connected to a signal transmitter by a wire harness, and the signal transmitter communicates signals from electrode assemblies **1004** to base unit **1002** wirelessly. In some embodiments, electrode assemblies **1004** are similar to electrode units **104** in FIG. 4A whereby electrode assemblies **1004** may be removably connected to base unit **1002** using suitable electrical, signal transmission connectors, which may comprise slidable locking electric connectors, spring-biased electric connectors, magnetic connectors and/or the like.

**[0110]** Electrode assemblies **1004** may be located relative to a subject's body **101** (e.g. around a person's head in a hat, a net and/or the like, embedded within, or attached to the inside of, a hat, cap, helmet, and/or the like (including the pad material, if any, inside any of the foregoing)) to generate signals indicative of electrical activity of the subject's brain at their corresponding locations and may wirelessly communicate these signals back to base unit **1002** at a location **105** away from the subject's body **101**. While electrical potentials of individual neurons in the brain may be too small to detect reliably, electrode assemblies **1004** and EEG system **1000** may detect activity of groups of neurons having similar spatial orientations. In the illustrated embodiment of FIG. 10, EEG system **1000** is shown as having three electrode assemblies **1004A, 1004B, 1004C** which may be used in a suitable configuration for generating EEG data. In some embodiments, third electrode assembly **1004C** is not necessary and system **1000** may use as few as two electrode assemblies **1004**. In some embodiments, system **1000** may be provided with more than three electrode assemblies **1004** (e.g. tens or even hundreds of electrode assemblies **1004**) to provide additional views of brain electrical activity

**[0111]** Base unit **1002** of EEG system **1000** and display **120** may be similar in many respects to base unit **402** of ECG system **400** and display **120** of ECG system **400** described herein. EEG waveforms **1010** generated by EEG system **1000** based on signals received from electrode assemblies **1004** may be shown on display **120** and display **120** may be

mounted in cradle 122 or removed from base unit 1002. Base unit 1002 may comprise suitably configured hardware and/or software components for processing signals from electrode assemblies 1004 and for generating corresponding EEG waveforms. In the illustrated embodiment of FIG. 10, base unit 1002 of EEG system 1000 comprises: controller 112, signal processing hardware 114, data storage 116, communications hardware 130 and user interface components 132. These components may be configured to provide particular functionality using suitably coded software (not explicitly shown). In some embodiments, communications hardware 130 may facilitate communication of EEG data (e.g. data stored in data storage 116, real time EEG waveforms 1010 and/or the like) from base unit 102 to an external EEG system 1024. Other than for dealing with EEG data (in addition to or in the alternative to ECG data) and possibly for dealing with external EEG system(s) 1024, these components of EEG system 1000 may be similar to the corresponding components of ECG system 400 described above. Base unit 1002 may comprise additional connectors 108 for optional connection to additional or alternative electrode units (not shown); and/or connections 134 for connecting to other medical equipment. Connectors 108 and connections 134 may be similar to those described above for ECG system 400.

[0112] In some embodiments, electrode units 104 and/or electrode assemblies 1004 are embedded into, contained within, or attached to the inside of helmets, such as firefighter helmets, athlete helmets, soldier helmets, and the like (including the padding, such as foam, contained therewithin). In these embodiments, EEG system 1000 may be used to monitor the electrical activity of the brain of the individual wearing the helmets, such as firefighters, athletes, soldiers, and the like. The brain activity as shown in the form of EEG waveforms 1010 may be used to assess the condition of the helmet-wearing individual to determine whether the individual is in the proper condition for performing the specific tasks.

[0113] In some embodiments, electrode units 104 and/or electrode assemblies 1004 are fixed on the head of an individual corresponding to the locations known as the 10-20 international system of EEG electrode placement. In some embodiments, electrode units 104 and/or electrode assemblies 1004 are held to the skin of the individual through fasteners such as tape, adhesives, clips, elastic strap(s) and/or the like. In some embodiments, electrode assemblies 1004 are held in place on or around a subject's head through the use of compression clamps. In some embodiments, electrode units 104 and/or electrode assemblies are not in contact with the skin of the individual. Electrode units 104 and/or electrode assemblies 1004 may additionally or alternatively be held using a holder arm firmly fixed to an individual's bed, chair, seat or other furniture around the individual. Electrode units 104 and/or electrode assemblies 1004 may additionally or alternatively be held in pockets of hats or in suitable netting. Such hats or netting may be elastically deformable to deform when a person's head is inserted therein, such that restorative forces associated with such deformation tend to hold the hat (and the corresponding electrode units 104 and/or electrode assemblies 1004) to the person's head in the correct locations desired for monitoring. In some embodiments, snap connectors may be used to hold such hats or netting in place.

[0114] Electrode units 104 or electrode assemblies 1004, may also be used, whether as part of a helmet, hat, headband, or other types of headgear on individuals, to allow doctors to monitor whether the individual is suffering from brain con-

ditions, such as strokes, seizures, hemorrhages, and the like. In some embodiments, EEG system 1000 comprises alarms which are sounded when EEG system 1000, after analyzing EEG waveforms 1010, determines that the individual is having trauma or some other detectable condition in the brain. In some embodiments, EEG system 1000 communicates EEG waveforms 1010 to a computing device (e.g. device 126A) that is operated by, or a display shown to, a doctor, technician, or the like, both of which allow the doctor, the technician, or the like to remotely monitor the brain activities of an individual. EEG system 1000 may be incorporated into medical diagnostic equipment, neuroprostheses or systems for use in detecting biofeedback, neuroimaging, brain-computer interfaces, interactive computer games, and the like. In some embodiments, EEG system 1000 can also be used to detect hearing in infants.

[0115] In some embodiments, EEG system 1000 may be installed in vehicles, such as cars, trucks, buses, planes, trains, and the like. Electrode units 104 and/or electrode assemblies 1004 may be installed or embedded into or contained within the interior of the vehicle, such as the steering wheel, seats (e.g. operator seat(s) and/or other seat(s)), headrests, dashboard, seat restraints (such as seat belts, safety belts, and/or the like), ceiling panel, ground panel, side panel, and/or the like. Base unit 1002 may be installed as part of the dashboard and/or control panel of the vehicle or be located in any other locations in the vehicle, such as the trunk or other storage space of the vehicle. In such installations, EEG system 1000 may or may not comprise display 120 or display 102 may comprise a part of the dashboard of the vehicle, the control panel of the vehicle, the entertainment system of the vehicle, heads-up display of the vehicle, or pop-up display in the vehicle.

[0116] In some embodiments, EEG waveforms 1010 may be analyzed by EEG system 1000 to assess the brain of a vehicle operator to determine whether the operator is suffering from a medical condition, is falling asleep, is drowsy, is driving under the influence of drugs, alcohol, or the like, or is otherwise impaired or unable to operate the vehicle appropriately. In some embodiments, EEG system 1000 is configured to send a distress signal, distress call, or warning signal to emergency responders, such as firefighters, police, and the like, emergency dispatch centers, or in-vehicle telematics service providers, when the brain of a vehicle operator is being affected by adverse medical conditions, trauma, or the like or when an accident has occurred, including accidents where one or more airbags have been activated. EEG system 1000 may contact emergency responders and emergency dispatch center through communication hardware 130, including through wireless communication modules. EEG system 1000 may also communicate EEG waveforms 1010 to emergency responders and medical personnel or allow data containing information about the EEG waveforms 1010 to be accessed and/or downloaded by emergency responders or medical personnel to assist the responders and medical personnel in diagnosing and treating the vehicle operator. In some embodiments, EEG system 1000 may interface or communicate with a vehicle's safety systems, such as active cruise control system, lane departure warning system, frontal collision warning system, precrash system, collision mitigating system, collision avoidance system, and/or the like to reduce the likelihood of an accident occurring while the vehicle operator is incapacitated or otherwise unable to operate the vehicle.

[0117] In one embodiment, EEG system 1000 is operatively connected to the vehicle's embedded software system such that EEG system 1000 can communicate with the vehicle's systems to effect changes in the vehicle's physical parts, such as the brakes, engine, and the like. When a vehicle operator steps into the vehicle (e.g. possibly, but not necessarily before starting the vehicle), a vehicle operator may be asked to place one electrode unit 104 and/or one electrode assembly 1004 onto the vehicle operator's head (operating in a current sensing mode or a contact field-sensing mode, in some embodiments) and one or more electrode units 104 and/or electrode assemblies 1004 embedded in the head rest of the vehicle operator's seat (operating in a non-contact field sensing mode, in some embodiments). It will be appreciated that, in some embodiments, additional or alternative locations of electrode units 104 and/or electrode assemblies 1004 could be used and that such electrode units (depending on their locations) could operate in current-sensing mode, field-sensing contact mode or field sensing non-contact mode. Signals detected by electrode units 104 and/or electrode assemblies 1004 may be used to generate corresponding EEG signals (e.g. EEG waveforms 1010), which may be analyzed (e.g. by controller 112, other controllers in EEG system 1000, or external EEG systems 1024 (communicating with EEG system 1000 through communications component 1024A)) to determine the state of the vehicle operator's brain. The analysis may be done through the use of software algorithms and may include comparison to other data sets. Where the EEG waveforms 1010 indicate the individual is incapacitated or is not in the proper condition to operate the vehicle, controller 112 communicates with the vehicle's on board system, which may act in accordance with instructions from controller 112. In some embodiment, if the EEG waveform 1010 indicates that the vehicle operator is going to fall asleep, is drowsy, or is already asleep, controller 112 communicates an alarm instruction to the vehicle system, and the vehicle system, upon receiving the instruction, will sound an alarm inside the vehicle or increase the volume of the radio and/or music playing in the entertainment system to wake the vehicle operator. In some embodiments, the alarm may be a vibration of the operator's seat to wake the vehicle operator. In further embodiments, the vehicle's infotainment system may ask the vehicle operator questions or require the vehicle operator to issue commands in order to wake, keep awake or otherwise maintain the alertness of the vehicle operator. In another embodiment, if the EEG waveform 1010 indicates that the vehicle operator is incapacitated, controller 112 will not permit the vehicle to start or will communicate a stop instruction to the vehicle's system, and the vehicle's system will turn on the vehicle's emergency stop lights and slowly brake the vehicle to a stop. EEG system 1000 may also communicate the vehicle operator's location and condition to emergency dispatchers such that emergency personnel can attend to the vehicle's vehicle operator quickly. Data from such vehicular EEG systems may be recorded—e.g. for forensic analysis, data analytics and/or the like.

[0118] FIG. 11 schematically illustrates an EMG system 1100 according to a particular embodiment. EMG system 1100 of the FIG. 11 embodiment is shown having a general architecture that is similar to ECG system 400 (FIG. 4D) and similar reference numerals are used to refer to features of EMG system 1100 that are similar to corresponding features of ECG system 400. It will be appreciated by those skilled in the art (given the description of ECG systems 100, 200, 300,

400 above and the description of EMG system 1100 below) that EMG system 1100 could be modified to have the general architecture of any of ECG systems 100, 200, 300, and 400. EMG system 1100 comprises a base unit 1102 and two or more electrode assemblies 1104A, 1104B, 1104C (collectively and individually electrode assemblies 1104). Consistent with the architecture of ECG system 400 (FIG. 4D), each electrode assembly 1104 of the illustrated embodiment of EMG system 1100 comprises a corresponding electrode unit 104A, 104B, 104C which may be similar to electrode units 104 described herein, but which may be configured for detection of skeletal muscle activity and corresponding EMG data. In some embodiments, electrode units 104 or electrode assemblies 1104 may comprise one or more capacitive sensor elements, each having an electrodynamic sensor sensitive to electromagnetic waves and an antenna comprising an electrically conducting radiating element for receiving electromagnetic waves as described elsewhere herein. By way of non-limiting example, electrode units 104 may comprise multi-mode electrode units similar to multi-mode electrode units 600 described herein. In some embodiments, electrode units 600 comprise capacitive sensor element 606 and the capacitive sensor element 606 comprises antenna component 652 and electrodynamic sensor 650 as described herein.

[0119] Consistent with the architecture of ECG system 400 (FIG. 4D), each electrode assembly 1104 of the illustrated embodiment of EMG system 1100 comprises corresponding signal processing components 1106A, 1106B, 1106C (collectively and individually signal processing components 1106) and communications components 1108A, 1108B, 1108C (collectively and individually communications components 1108). Signal processing components 1106 and communications components 1108 may be similar to signal processing components 406 and communications components 408 described herein, but may be configured for detection of skeletal muscle activity and corresponding EMG data.

[0120] Base unit 1102 may be positioned at a location 105 away from the individual's body 101 and electrode assemblies 1104 may communicate measured signals or data back to base unit 1102. In some embodiments, electrode assemblies 1104 may be electrically connected to one another (e.g. to provide a common ground or reference potential). In some embodiments, electrode assemblies 1104 may share some of signal processing components 1106 and/or communications components 1108. In some embodiments, electrode assemblies 1104 may comprise suitably configured controllers (not shown) which may control signal processing components 1106 and/or communications components 1108.

[0121] Electrode assemblies 1104 may be located relative to an individual's body 101 (e.g. in suitable locations relative to specific muscles and/or the like) to generate signals indicative of electrical activity of an individual's skeletal muscle at their corresponding locations and may wirelessly communicate these signals back to base unit 1102 at a location 105 away from the individual's body 101. In the illustrated embodiment of FIG. 11, EMG system 1100 is shown as having three electrode assemblies 1104A, 1104B, 1104C which may be used in a suitable configuration for generating EMG data. In some embodiments, third electrode assembly 1104C is not necessary and system 1100 may use as few as two electrode assemblies 1104. In some embodiments, system 1100 may be provided with more than three electrode assemblies 1104 to provide additional views of skeletal muscle electrical activity. Electrode units 104 and/or elec-

trode assemblies **1104** may detect electrical signals from the skeletal muscles in current-sensing mode, field-sensing contact mode and/or field sensing non-contact mode. In one embodiment, one electrode unit **104** and/or electrode assembly **1104** detects electrical signals from a skeletal muscle in current-sensing mode with the other electrode unit **104** and/or electrode assembly **1104** in field-sensing contact mode or field sensing non-contact mode. In other embodiments, electrode units **104** and/or electrode assemblies **1104** may all operate in field-sensing non-contact mode to detect electrical signals from the skeletal muscle. In some embodiments, electrode units **104** and/or electrode assemblies **1104** may operate in a combination of field-sensing contact mode and field-sensing non-contact mode.

[0122] Base unit **1102** of EMG system **1100** and display **120** may be similar in many respects to base unit **402** of ECG system **400** and display **120** of ECG system **400** described herein. EMG waveforms **1110** generated by EMG system **1100** based on signals received from electrode assemblies **1104** may be shown on display **120** and display **120** may be mounted in cradle **122** or removed from base unit **1102**. Base unit **1102** may comprise suitably configured hardware and/or software components for processing signals from electrode assemblies **1104** and for generating corresponding EMG waveforms. In the illustrated embodiment of the FIG. **11** EMG system **1100**, base unit **1102** comprises: controller **112**, signal processing hardware **114**, data storage **116**, communications hardware **130** and user interface components **132**. These components may be configured to provide particular functionality using suitably coded software (not explicitly shown). In some embodiments, communications hardware **130** may facilitate communication of EMG data (e.g. data stored in data storage **116**, real time EMG waveforms **1110** and/or the like) from base unit **1102** to an external EMG system **1124**. Other than for dealing with EMG data (in addition to or in the alternative to ECG data) and possibly for dealing with external EMG system(s) **1124**, these components of EMG system **1100** may be similar to the corresponding components of ECG system **400** described above. Base unit **1102** may comprise additional connectors **108** for optional connection to additional or alternative electrode units (not shown); and/or connections **134** for connecting to other medical equipment. Connectors **108** and connections **134** may be similar to those described above for ECG system **400**. In the embodiment illustrated in FIG. **11**, electrode assemblies **1104** communicate wirelessly to base unit **1102**. In some embodiments, one or more than one of electrode assemblies **1104** may be physically connected to base unit **1102** by corresponding cables and may communicate to base unit **1102** through such cables. In some embodiments, electrode assemblies **1104** may be physically connected to a signal transmitter by a wire harness, and the signal transmitter communicates signals from electrode assemblies **1104** to base unit **1102** wirelessly. In some embodiments, electrode assemblies **1104** are similar to electrode units **104** in FIG. **4A** whereby electrode assemblies **1104** may be removably connected to base unit **1102** using suitable electrical, signal transmission connectors, which may comprise slidable locking electric connectors, spring-biased electric connectors, magnetic connectors and/or the like.

[0123] In some embodiments, electrode assemblies **1104** are in direct contact with the skin of an individual. In other embodiments, electrode assemblies **1104** are not in contact with the skin of an individual. In one embodiment, electrode

assemblies **1104** are mounted on an individual's body using a stretch band stretching around a limb with the band either endless or with the ends of the band fixed together by fasteners such as hook and loop fasteners, pins, buckles, and the like. In some embodiment, electrode assemblies **1104** are embedded into, contained within, incorporated into, or attached to sports equipment, such as fitness bands, shin pad, shin guard, knee pad, elbow pad, arm pad, shoulder pad, leg guard, chest protector, body pad, wrist pad, glove, and/or the like. In some embodiments, electrode assemblies **1104** are held in place on or around specific muscles through the use of compression clamps.

[0124] EMG system **1100** may also be used to monitor the activity of specific skeletal muscles of individuals, such as patients, athletes, soldiers, and the like. EMG waveforms **1110** may further be used to diagnose and/or assessing neuromuscular disease, back pain, motor control disorder, neuropathies, neuromuscular junction diseases, myopathies and/or the like. EMG signals detected by EMG system **1100** may also be used as control signals for prosthetic devices such as prosthetic hands, arms, lower limbs, and the like. EMG signals may further be used to assess strength, condition, and fatigue levels of specific muscles.

[0125] In one embodiment, an athlete wears a pad (e.g. a shin guard and/or the like) that incorporates two or more electrode assemblies **1104**. One electrode assembly **1104** directly contacts the skin of the individual and operates in current sensing mode and/or field sensing contact mode. The other electrode assembly **1104** is not in direct contact with the skin and operates in field sensing non-contact mode. In some embodiments, both electrode assemblies **1104** operate in field sensing non-contact mode. It will be appreciated that, in some embodiments, additional or alternative locations of electrode units **104** and/or electrode assemblies **1104** could be used and that such electrode units (depending on their locations) could operate in current-sensing mode, field-sensing contact mode or field sensing non-contact mode. EMG waveforms **1110** are then analyzed by controller **112**, other controllers in EMG system **1100**, or external EMG system **1124** (which may be in communication with base unit **1102** through external EMG communication component **1124A**) through the use of software algorithms. EMG waveforms **1110** may also be shown on display **120** in EMG system **1100** and analyzed by technicians, physicians, coaches, the athlete himself or herself, and the like. EMG waveforms **1100** may be used to determine the state of an individual's skeletal muscle (e.g. the muscle(s) under the athlete's pad), such as the tibialis anterior muscle. Such analysis of skeletal muscle activity can be used to ascertain muscle fatigue, muscle damage, muscle strength, muscle condition and/or the like.

[0126] In some embodiments, EMG system **1100** may be installed in vehicles, such as cars, trucks, busses, planes, trains, and the like. Electrode units **104** and/or electrode assemblies **1104** may be installed or embedded into or contained within the interior of the vehicle, such as the seats, arm rests, seat restraints, and/or the like. In some embodiments EMG system **1100** is used with adjustable seat systems, such as adjustable seats in vehicles, office chairs, massage chairs, and/or the like. EMG system **1100** uses EMG waveforms **1110** to determine the strain in of skeletal muscles of an individual sitting in the seats. EMG system **1100** may then communicate with the controller of the adjustable seat systems to adjust the characteristics of the seats, such as curvature, height, tilt, and/or the like, to reduce the strain in the

individual's skeletal muscles. In some embodiments, EMG system 1100 may interface or communicate with a vehicle's safety systems, such as active cruise control system, lane departure warning system, frontal collision warning system, precrash system, collision mitigating system, collision avoidance system, and/or the like to reduce the likelihood of an accident occurring while the vehicle operator is incapacitated or otherwise unable to operate the vehicle.

[0127] In some embodiments, EMG system 1100 is used as part of a human-machine interface in which EMG signals and EMG waveforms 1110 are used for detecting the motion of an individual. Such detection can then be used for interpreting gestures performed by the individual. In some embodiments, EMG system 1100 is incorporated into medical diagnostic equipment or neuroprostheses.

[0128] FIG. 12 schematically illustrates an EOG system 1200 according to a particular embodiment. EOG system 1200 of the FIG. 12 embodiment is shown having a general architecture that is similar to ECG system 400 (FIG. 4D) and similar reference numerals are used to refer to features of EOG system 1200 that are similar to corresponding features of ECG system 400. It will be appreciated by those skilled in the art (given the description of ECG systems 100, 200, 300, 400 above and the description of EOG system 1200 below) that EOG system 1200 could be modified to have the general architecture of any of ECG systems 100, 200, 300, and 400. EOG system 1200 comprises a base unit 1202 and two or more electrode assemblies 1204A, 1204B, 1204C (collectively and individually electrode assemblies 1204). Consistent with the architecture of ECG system 400 (FIG. 4D), each electrode assembly 1204 of the illustrated embodiment of EOG system 1200 comprises a corresponding electrode unit 104A, 104B, 104C which may be similar to electrode units 104 described herein, but which may be configured for detection of corneo-retinal potential and corresponding EOG data. In some embodiments, electrode units 104 or electrode assemblies 1204 may comprise one or more capacitive sensor elements, each having an electrodynamic sensor sensitive to electromagnetic waves and an antenna comprising an electrically conducting radiating element for receiving electromagnetic waves as described elsewhere herein. By way of non-limiting example, electrode units 104 may comprise multi-mode electrode units similar to multi-mode electrode units 600 described herein. In some embodiments, electrode units 600 comprise capacitive sensor element 606 and the capacitive sensor element 606 comprises antenna component 652 and electrodynamic sensor 650 as described herein.

[0129] Consistent with the architecture of ECG system 400 (FIG. 4D), each electrode assembly 1204 of the illustrated embodiment of EOG system 1200 comprises corresponding signal processing components 1206A, 1206B, 1206C (collectively and individually signal processing components 1206) and communications components 1208A, 1208B, 1208C (collectively and individually communications components 1208). Signal processing components 1206 and communications components 1208 may be similar to signal processing components 406 and communications components 408 described herein, but may be configured for detection of electrical activity of the eye and corresponding EOG data.

[0130] Base unit 1202 may be positioned at a location 105 away from the individual's body 101 and electrode assemblies 1204 may communicate measured signals or data back to base unit 1202. In some embodiments, electrode assemblies 1204 may be electrically connected to one another (e.g.

to provide a common ground or reference potential). In some embodiments, electrode assemblies 1204 may share some of signal processing components 1206 and/or communications components 1208. In some embodiments, electrode assemblies 1204 may comprise suitably configured controllers (not shown) which may control signal processing components 1206 and/or communications components 1208.

[0131] Electrode assemblies 1204 may be located relative to an individual's body 101 (e.g. in suitable locations relative to the individual's eye) to generate signals indicative of electrical activity of the individual's eye at their corresponding locations and may wirelessly communicate these signals back to base unit 1202 at a location 105 away from the individual's body 101. In the illustrated embodiment of FIG. 12, EOG system 1200 is shown as having three electrode assemblies 1204A, 1204B, 1204C which may be used in a suitable configuration for generating EOG data. In some embodiments, third electrode assembly 1204C is not necessary and system 1200 may use as few as two electrode assemblies 1204. In some embodiments, system 1200 may be provided with more than three electrode assemblies 1204 to provide additional views of corneo-retinal electrical activity. Electrode assemblies 1204 may detect corneo-retinal electrical activity in current-sensing mode, field-sensing contact mode and/or field sensing non-contact mode. In one embodiment, electrode assembly 1204A detects electrical signals from the brain in current-sensing mode with the other electrode assembly 1204 in field-sensing contact mode or field sensing non-contact mode. In other embodiments, electrode assemblies 1204 may all operate in field-sensing non-contact mode to detect electrical signals from the brain. In some embodiments, electrode assemblies 1204 may operate in a combination of field-sensing contact mode and field-sensing non-contact mode.

[0132] Base unit 1202 of EOG system 1200 and display 120 may be similar in many respects to base unit 402 of ECG system 400 and display 120 of ECG system 400 described herein. EOG waveforms 1210 generated by EOG system 1200 based on signals received from electrode assemblies 1204 may be shown on display 120 and display 120 may be mounted in cradle 122 or removed from base unit 1202. Base unit 1202 may comprise suitably configured hardware and/or software components for processing signals from electrode assemblies 1204 and for generating corresponding EOG waveforms. In the illustrated embodiment of the FIG. 12, EOG system 1200, base unit 1202 comprises: controller 112, signal processing hardware 114, data storage 116, communications hardware 130 and user interface components 132. These components may be configured to provide particular functionality using suitably coded software (not explicitly shown). In some embodiments, communications hardware 130 may facilitate communication of EOG data (e.g. data stored in data storage 116, real time EOG waveforms 1210 and/or the like) from base unit 102 to an external EOG system 1224. Other than for dealing with EOG data (in addition to or in the alternative to ECG data) and possibly for dealing with external EOG system(s) 1224, these components of EOG system 1200 may be similar to the corresponding components of ECG system 400 described above. Base unit 1202 may comprise additional connectors 108 for optional connection to additional or alternative electrode units (not shown); and/or connections 134 for connecting to other medical equipment. Connectors 108 and connections 134 may be similar to those described above for ECG system 400. In the embodiment

illustrated in FIG. 12, electrode assemblies 1204 communicate wirelessly to base unit 1202. In some embodiments, one or more than one of electrode assemblies 1004 may be physically connected to base unit 1202 by corresponding cables and may communicate to base unit 1202 through such cables. In some embodiments, electrode assemblies 1204 may be physically connected to a signal transmitter by a wire harness, and the signal transmitter communicates signals from electrode assemblies 1204 to base unit 1202 wirelessly. In some embodiments, electrode assemblies 1204 are similar to electrode units 104 in FIG. 4A whereby electrode assemblies 1204 may be removably connected to base unit 1202 using suitable electrical, signal transmission connectors, which may comprise slidable locking electric connectors, spring-biased electric connectors, magnetic connectors and/or the like.

[0133] In some embodiments, a pair of electrode assemblies 1204 is placed above and below the eye. In other embodiments, the pair of electrode assemblies 1204 is placed to the left and right of the eye. In some embodiments, electrode assemblies 1204 are embedded into, contained within, incorporated into, or attached to a frame, glasses, goggles, and the like. Signals detected by EOG system 1200 and/or EOG waveforms 1210 may be used to diagnose ophthalmological conditions such as Best's disease, macular dystrophy, retinitis pigmentosa, other retinal conditions and/or the like. In one embodiment, one of the electrode assemblies 1204 is in direct contact with the skin around the eye and the other electrode assembly 1204 is not in direct contact with the skin. In other embodiments, the electrode assemblies 1204 are both not in direct contact with the skin. In some embodiments, electrode assemblies 1204 are held in place on or around a subject's eyes through the use of compression clamps.

[0134] In some embodiments, EOG system 1200 is used to track eye movement of the individual. In some embodiments, EOG system 1200 is used to track the eye movement for actors who are performing motion capture for animated films. In some embodiments, EOG system 1200 may be used by individuals giving presentations. In some embodiments, EOG system 1200 may be used with entertainment systems, such as televisions, movie theatres, game consoles, and/or the like to track eye movement of the individual.

[0135] In some embodiments, EOG system 1200 may be used as part of a vehicle safety system. As an example, before operating a vehicle, the vehicle operator may be to first wear a frame around the operator's face with electrode assemblies 1204 mounted on the frame such that one of the electrode assemblies 1204 will be in contact with the skin of the vehicle operator near one of the eyes. The electrode assembly 1204 in contact with the skin may operate in current sensing mode and/or field-sensing contact mode and the other electrode unit 1204 on the frame may operate in field sensing non-contact mode. In other embodiments, electrode assemblies 1204 are located near the eye but not in contact with the skin of the vehicle operator. It will be appreciated that, in some embodiments, additional or alternative locations of electrode units 104 and/or electrode assemblies 1204 could be used and that such electrode units (depending on their locations) could operate in current-sensing mode, field-sensing contact mode or field sensing non-contact mode. Signals detected from electrode assemblies 1204 are sent to signal processing system 114 in base unit 1202 by wireless communications. Signals are then processed by signal processing system 114 to generate corresponding EOG signals (e.g. EOG waveforms

1210). EOG waveforms 1210 are then analyzed by controller 112, other controllers in EOG system 1200, or external EOG system 1224 through the use of software algorithms to determine the eye movement of the vehicle operator. In one embodiment, when the EOG waveforms 1210 indicate that the individual is impaired, such as by alcohol, drugs, tiredness and/or the like, controller 112 communicates with the vehicle's on board system, which may act in accordance with instructions from controller 112. In some embodiment, if the EOG waveform 1210 indicates that the vehicle operator is going to fall asleep, is drowsy, or is already asleep, controller 112 communicates an alarm instruction to the vehicle system, and the vehicle system, upon receiving the instruction, will sound an alarm insides the vehicle or increase the volume of the radio and/or music playing in the entertainment system to wake the vehicle operator. In some embodiments, the alarm may be a vibration of the operator's seat to wake the vehicle operator. In further embodiments, the vehicle's infotainment system may ask the vehicle operator questions or require the vehicle operator to issue commands in order to wake or keep awake the vehicle operator. In another embodiment, if the EOG waveform 1210 indicates that the vehicle operator is incapacitated, controller 112 will not permit the vehicle to start or will communicate a stop instruction to the vehicle's system, and the vehicle's system will turn on the vehicle's emergency stop lights and slowly brake the vehicle to a stop. EOG system 1200 may also communicate the vehicle operator's location and condition to emergency dispatchers such that emergency personnel can attend to the vehicle's vehicle operator quickly. Data from such vehicular EOG systems may be recorded—e.g. for forensic analysis, data analytics and/or the like. In some embodiments, EOG system 1200 may be incorporated into military vehicles for use in adjusting weapon targeting systems and/or determining the state of the vehicle and/or weapon system operator. In some embodiments, EOG system 1200 may interface or communicate with autonomous driving systems in a vehicle. In some embodiments, the autonomous driving system may take over operation of the vehicle where the EOG system 1200 indicates that the vehicle operator incapacitated or otherwise unable to operate the vehicle. In some embodiments, EOG system 1200 may interface or communicate with a vehicle's safety systems, such as active cruise control system, lane departure warning system, frontal collision warning system, precrash system, collision mitigating system, collision avoidance system, and/or the like to reduce the likelihood of an accident occurring while the vehicle operator is incapacitated or otherwise unable to operate the vehicle.

[0136] In one embodiment, a vehicle, such as a car, truck, bus, plane, train, ship, and the like, comprises ECG systems 100, 200, 300, 400, 900, EEG system 1000, EMG system 1100, or EOG systems 1200, or a combination of all or some of the foregoing systems. The state of drowsiness of a vehicle operator may be determined solely by ECG data (e.g. ECG waveform 110), EEG data (e.g. EEG waveforms 1010), EMG data (e.g. EMG waveform 1110), or EOG data (e.g. EOG waveform 1210) or a combination of all or some of foregoing data. The use of sensors to provide ECG signals, EEG signals, EMG signals, and EOG signals for determining drowsiness of a vehicle operator is discussed in Sahayadhas, Arun et al., "Detective Driver Drowsiness Based on Sensors: A Review", *Sensors* 2012, 12, 16937-16953, and the content of the publication is hereby incorporated by reference in its entirety. In these embodiments, ECG data, EEG data, EMG data, or EOG

data may be generated from signals received by electrode assemblies, and these electrode assemblies may comprise multi-mode electrode units similar to multi-mode electrode units **600** described herein. These multi-mode electrode units may operate in contact mode (current-sensing) or non-contact mode (current sensing or field sensing), depending on the location or position of the vehicle operator. In some embodiments, electrode units **600** comprise capacitive sensor element **606** and the capacitive sensor element **606** comprises antenna component **652** and electrodynamic sensor **650** as described herein. In some embodiments, the same electrode assemblies are used to detect different signals from the vehicle operator. In other embodiments, different electrode assemblies are used to detect signals from different physiological electrical activities of the vehicle operator (e.g. electrical activity of an organ, such as the heart (e.g. the heart muscle), brain, eye, or skeletal and/or other muscle).

[0137] In one embodiment, ECG systems **100**, **200**, **300**, **400**, **900**, EEG system **1000**, EMG system **1100**, or EOG systems **1200**, or a combination of all or some of the foregoing systems, are used to monitor infants, babies, toddlers, or young children. Electrode assemblies, which may comprise multi-mode electrode units similar to multi-mode electrode units **600** described herein embedded within car seats, cribs, strollers, and/or the like and/or in seat restraints, such as a seat belt, safety belt, and/or the like, may detect electrical activity from different physiological electrical activities ((e.g. electrical activity of an organ, such as the heart (e.g. the heart muscle), brain, eye, or skeletal and/or other muscle)) of the infants, babies, toddlers, or young children by operating in current-sensing mode, field-sensing contact mode or field sensing non-contact mode (depending on the location or position of the infant, baby, toddler, or young child). ECG data (e.g. ECG waveform **110**), EEG data (e.g. EEG waveforms **1010**), EMG data (e.g. EMG waveform **1110**), or EOG data (e.g. EOG waveform **1210**) may then be generated from the signals received by the electrode assemblies and analyzed as described herein. ECG data, EEG data, EMG data, or EOG data may then be transmitted to a phone, tablet, computer, laptop, website, and/or the like, and displayed to a parent, guardian, babysitter, teacher, and/or the like to monitor the state of the infant, baby, toddler, or young child. In some embodiments, temperature sensor may also be added to provide temperature information of the infant, baby, toddler, or young child with the ECG data, EEG data, EMG data, or EOG data or a combination of some or all such data.

[0138] While a number of exemplary aspects and embodiments have been discussed above, those of skill in the art will recognize certain modifications, permutations, additions and sub-combinations thereof. For example:

[0139] In the illustrated embodiment of FIGS. **6A** and **6B**, cable **624** is shown as being permanently attached to sensor portion **604**. This is not necessary. In some embodiments, cable **624** may be attached to clamp portion **602** and the outputs of sensor portion **604** (e.g. sensed signals) may be connected to cable **624** by suitable electrical contact(s) between clamp portion **602** and sensor portion **604**. In some embodiments, connections to resistive sensor elements (e.g. snap mechanism **622** and/or clamp contacts **636**) can be routed through clamp portion **602** without the need for sensor portion **602**.

[0140] In some embodiments, clamp portion **602** of electrode unit **600** may be fabricated from bacteria resistant material (e.g. suitable plastic and/or the like).

[0141] In some embodiments, ECG systems **100**, **200**, **300**, **400** may be configured to provide a heart-shaped graphic on display **120** and to interpret the ECG data to cause the heart-shaped graphic to simulate actual heart-muscle activity as detected in the ECG data.

[0142] In some embodiments, multi-mode electrode units **600** (or any variations of multi-mode electrodes **600** described herein) may be connected to prior art ECG, EEG, EMG, or EOG systems—e.g. in the place of conventional electrode units. When connected in this manner, suitable adapters may be used to provide output signals from electrode units **600** in a format useable by the prior art ECG, EEG, EMG, or EOG system.

[0143] In some embodiments, cables (e.g. cables **106**, cables **624**) associated with the various electrode units or electrode assemblies described herein may be retractable and may be housed, for example, in the base unit or in the housing of the electrode unit or electrode assemblies, as applicable.

[0144] In some embodiments, an electrode unit comprising a capacitive sensor element **606** (see FIGS. **6A**, **6B**) could be incorporated into a blood pressure cuff and attached to the body of an individual via the blood pressure cuff to sense heart muscle electrical activity in a field-sensing contact or field-sensing non-contact mode.

[0145] In some embodiments, electrode units (e.g. electrode units **104**) and/or electrode assemblies (e.g. electrode assemblies **404**) of the type described herein may be used in non-contact field-sensing mode for locating individuals (e.g. by their heart activity or similar electrical activity) in a nonvisible environment—e.g. as part of search and rescue operation in rubble, avalanche, smoky rooms and/or the like. In some embodiments, electrode units (e.g. electrode units **104**) and/or electrode assemblies (e.g. electrode assemblies) **404** of the type described herein may be used in non-contact field-sensing mode for motion detection systems. In some embodiments, electrode units and/or electrode assemblies may be used at sporting events or in public or private areas.

[0146] In some embodiments, electrode units (e.g. electrode units **104**) and/or electrode assemblies (e.g. electrode assemblies **404**) of the type described herein may comprise capacitive sensor elements having an electrodynamic sensor sensitive to electromagnetic waves and an antenna comprising an electrically conducting radiating element for receiving electromagnetic waves as described elsewhere herein.

[0147] Embodiments are described above wherein EEG system **1000** and EOG system **1200** are implemented in a vehicle. In some embodiments, any of the ECG systems described herein and/or EMG system **1100** may be implemented in a vehicular setting. Such embodiments may comprise embedding electrode units and/or electrode assemblies into components of the vehicle, such as (without limitation): the steering wheel, the dashboard, the vehicle ceiling, the vehicle floor, the vehicle seat(s), seat restraints, and/or the like. Such ECG and EMG systems can be used to determine the state of the heart muscle and/or the skeletal and/or other muscle of the vehicle operator. Such information may be communicated to first responders or suitable authorities in the event of an accident or during normal vehicular operation periods. Such embodiments can also alert the

vehicle operator (using suitable alarms and/or the like) that the vehicle operator is having a heart attack or similar heart condition. Data from such vehicular ECG systems and/or EMG systems may be recorded—e.g. for forensic analysis, data analytics and/or the like.

**[0148]** In some embodiments, a plurality of ECG systems **100, 200, 300, 400, 900**, EEG systems **1000**, EMG system **1100** and EOG systems **1200** may be implemented together in a vehicle for the purpose of having redundant systems. Such systems may share a number of common hardware components. The results from one system may be used to confirm or augment the results from the other system.

**[0149]** ECG systems **100, 200, 300, 400, 900**, EEG system **1000**, EMG system **1100**, and/or EOG systems **1200** may communicate ECG, EEG, EMG, and/or EOG waveforms, as applicable, to a mobile device such as a phone, tablet, and/or the like. In some embodiments, these waveforms may be communicated to a website, cloud storage, or other online databases.

**[0150]** Signals received by electrode units (e.g. electrode units **104**) and/or electrode assemblies (e.g. electrode assemblies **404**) for ECG systems such as ECG systems **100, 200, 300, 400, and 900** may be analyzed to determine respiration patterns of an individual, and the respiration information may be used alone or in conjunction with ECG data (e.g. ECG waveforms) or other data (such as EEG data, EMG data, or EOG data) to determine the state of the individual, such as whether the individual is asleep, drowsy, impaired, or is suffering from medical conditions

**[0151]** Signals received by electrode units and/or electrode assemblies for ECG systems such as ECG systems **100, 200, 300, 400, 900**, EEG systems such as EEG system **1000**, EMG systems such as EMG system **1100**, and/or EOG systems such as EOG system **1200** may be analyzed alone or in combination with other signals to determine the medical state of an individual such as drowsiness, unconsciousness, incapacity, brain injury, stroke, arrhythmias, compensated shock, decompensated shock, sepsis, heart attack, sleep, stress, attentiveness, cognition, respirations, internal bleeding, and/or the like.

**[0152]** Software may be used to interpret ECG waveforms, EEG waveforms, EMG waveforms, and/or EOG waveforms together to provide detailed information about the state of an individual.

**[0153]** The electrode units (e.g. electrode units **104**) and/or electrode assemblies (e.g. electrode assemblies **404**) of the type described herein may be used to measure ECG, EEG, EMG, and/or EOG signals based on instructions from software from the applicable system.

**[0154]** The electrode units (e.g. electrode units **104**) and/or electrode assemblies (e.g. electrode assemblies **404**) of the type described herein may also be incorporated or embedded into electronic devices, such as phones, tablets, laptop computers, desktop computers, smart watches, activity trackers, and the like, and/or casing or other protective gear for such devices.

**[0155]** The systems and methods described herein are not limited to humans and may be used for monitoring of animals, such as pet animals or animals at zoos.

**[0156]** Display **120** of ECG systems **100, 200, 300, 400, 900**, EEG systems **1000**, EMG system **1100** and EOG

systems **1200** may be the displays of electronic devices, such as phones, tablets, laptop computers, desktop computers, smart watches, and/or the like.

**[0157]** ECG systems **100, 200, 300, 400, 900**, EEG systems **1000**, EMG system **1100** and EOG systems **1200** may be used for detection of signals from individuals located in or travelling with public areas, such as streets, malls, airports, ports, and/or the like.

**[0158]** Where the electrode units described herein capture signals related to the operation of cell(s), tissue(s), organ(s) and/or system(s), the controllers of the systems described herein may be configured to use these signals (individually and/or together) to create and display an animation on a suitable display. The animation may be based on the one or more signals and may show the operation of the cell(s), tissue(s), organ(s) and/or system(s).

**[0159]** EMG systems described elsewhere herein are described in connection with skeletal muscle. This is not necessary. In general, the EMG systems described herein may be used in connection with the electrical activity of other (non-skeletal) muscles and/or a combination of skeletal and other muscles.

**[0160]** It is therefore intended that the scope of the following appended claims and claims hereafter introduced should not be limited by the embodiments set forth in the examples, but should be given the broadest interpretation consistent with the description as a whole.

What is claimed is:

1. A system for sensing physiological electrical activity in an individual comprising:

a first electrode unit for generating a first signal indicative of the physiological electrical activity at a first location on a body of the individual; and

a second electrode unit for generating a second signal indicative of the physiological electrical activity at a second location on the body of the individual;

wherein each of the first and second electrode units is configurable to operate in:

a field-sensing mode wherein the electrode unit is configured to generate its corresponding signal based on a detected electric field at a location on or in proximity to the individual's skin; and,

wherein each of the first and second electrode units comprises a capacitive sensor element, the capacitive sensor element of each of the electrode units comprising:

an electrodynamic sensor which is sensitive to electromagnetic waves; and

an antenna comprising an electrically conductive radiating element for receiving electromagnetic waves, the radiating element in electrical contact with a sensing surface of the electrodynamic sensor and having a surface area which is larger than a surface area of the sensing surface of the electrodynamic sensor, the antenna located relatively more proximate than the electrodynamic sensor to the individual's skin during operation of the electrode unit in the field-sensing mode.

2. A system according to claim 1 wherein the physiological electrical activity comprises electrical activity of an organ, the organ comprising a heart, a brain, an eye, or a skeletal muscle.

3. A system according to claim 2 wherein the organ comprises the heart and system is configured to combine the first and second signals to generate an ECG waveform.

4. A system according to claim 2 wherein the organ comprises the brain and the system is configured to combine the first and second signals to generate an EEG waveform.

5. A system according to claim 2 wherein the organ comprises the eye and the system is configured to combine the first and second signals to generate an EOG waveform.

6. A system according to claim 2 wherein the organ comprises the skeletal muscle and the system is configured to combine the first and second signals to generate an EMG waveform.

7. A system according to claim 1 wherein the capacitive sensor element of each of the electrode units comprises an electrically non-conductive layer disposed on the radiating element, wherein the non-conductive layer is on an outside face of the electrode unit which is located relatively more proximate than the radiating element to the individual's skin during operation of the electrode unit in the field-sensing mode.

8. A system according to claim 7 wherein the electrically non-conductive layer comprises a metallization layer electrically connected to an inner metallization layer in direct electrical contact with the electrodynamic sensor.

9. A system according to claim 8 comprising an insulator layer to provide a compressive force for facilitating the direct electrical contact.

10. A system according to claim 1 comprising a distal component to provide electrical noise shielding.

11. A system according to claim 1 wherein at least one of the electrode units comprises a clamp.

12. A system according to claim 11 wherein the clamp is provided in a clamp portion of the electrode unit, the capacitive sensor element is provided in a sensor portion of the electrode unit and the clamp portion and sensor portion are attachable to, and detachable from, one another.

13. A system according to claim 11 wherein the clamp comprises a pair of clamp teeth for clamping objects therebetween and the clamp is shaped to clamp the individual's clothing between the clamp teeth and to thereby affix the at least one electrode unit to the individual's clothing.

14. A system according to claim 11 wherein the clamp comprises a pair of clamp teeth for clamping objects therebetween and one or more electrically conducting clamp contacts located in one or both of the teeth for clamping a portion of a resistive sensor element between the clamp teeth and corresponding electrical attachment of the resistive sensor element to the one or more clamp contacts, and wherein the at least one of the electrode units is configurable to operate in a current-sensing mode wherein the electrode unit is configured to generate its corresponding signal based on current flow through the resistive sensor element placed directly on the individual's skin.

15. A system according to claim 1 wherein at least one of electrode units comprises a first connector component for receiving a second complementary connector component of a resistive sensor element for removably electrically connecting the resistive sensor element to the electrode unit by connecting the first and second connector components, and wherein the at least one of the electrode units is configurable to operate in a current-sensing mode wherein the electrode unit is configured to generate its corresponding signal based

on current flow through the resistive sensor element placed directly on the individual's skin.

16. A system according to claim 15 wherein the first and second connector components are shaped such that connecting the first and second connector components causes deformation of at least one of the first and second connector components and corresponding restorative forces which tend to maintain the connection between the first and second connector components.

17. A system according to claim 1 wherein the capacitive sensor element of each electrode unit comprises a first connector component for receiving a second complementary connector component of a resistive sensor element for removably electrically connecting the resistive sensor element to the electrode unit by connecting the first and second connector components, the first connector component located on a side of the electrodynamic sensor opposite that of the antenna, and wherein the at least one of the electrode units is configurable to operate in a current-sensing mode wherein the electrode unit is configured to generate its corresponding signal based on current flow through the resistive sensor element placed directly on the individual's skin.

18. A system according to claim 1 wherein at least one of the electrode units comprises a first sensor configured to detect a presence of a resistive sensor element electrically connected to the at least one of the electrode units.

19. A system according to claim 18 wherein the at least one of the electrode units comprises a second sensor configured to detect proximity of the individual's skin and to thereby permit determination of whether the electrode unit is operating in a non-contact field-sensing mode wherein the at least one of the electrode units is not in contact with the individual's skin or a contact field-sensing mode wherein the at least one of the electrode units is in contact with the individual's skin.

20. A system according to claim 1 wherein the first electrode unit is operating in a non-contact field-sensing mode wherein the first electrode unit is not in contact with the individual's skin simultaneously with the second electrode unit operating in a contact field-sensing mode wherein the second electrode unit is in contact with the individual's skin and wherein the system is configured to combine the first signal and the second signal to generate a waveform.

21. A system according to claim 1 wherein the system is configured to combine the first signal and the second signal to generate one or more waveforms and to use the waveforms to determine a medical state of the individual.

22. A system according to claim 1 wherein the second electrode is configurable to operate in a current sensing mode wherein the second electrode unit is configured to generate its corresponding signal based on current flow through a resistive sensor element placed directly in contact with the individual's skin and wherein the first electrode unit is operating in the field-sensing mode simultaneously with the second electrode unit operating in the current-sensing mode and wherein the system is configured to combine the first signal and the second signal to generate a waveform.

23. A system according to claim 1 comprising a base unit connected to the electrode units to receive the first and second signals, the base unit comprising a digital signal processor configured to generate one or more waveforms based on a combination of the first and second signals.

24. A system according to claim 23 wherein the system is incorporated into a vehicle and at least one of the electrode units and the base unit are located in the interior of the vehicle.

25. A system according to claim 24 wherein the electrode unit is embedded into a seat in the vehicle and the base unit is incorporated into the head unit of the vehicle.

26. A system according to claim 25 wherein at least one of the electrode units is wirelessly connected to the base unit.

27. A system according to claim 23 wherein the base unit is configured to display the one or more waveforms on a display.

28. A system according to claim 27 wherein at least one of the electrode units is incorporated into the steering control of the vehicle.

29. A system according to claim 23 wherein the system is configured to use the waveforms to determine a medical state of an operator of the vehicle.

30. A system according to claim 25 wherein the medical state is drowsiness, unconsciousness, incapacity, brain injury, stroke, arrhythmias, compensated shock, decompensated shock, sepsis, heart attack, sleep, stress, attentiveness, cognition, respirations, or internal bleeding.

31. An electrode unit for use in sensing physiological electrical activity in an electrical activity monitoring system, the electrode unit comprising:

a capacitive sensor element for detecting electric field, the capacitive sensor element comprising:

an electrodynamic sensor sensitive to electromagnetic waves;

an antenna comprising an electrically conductive radiating element for receiving electromagnetic waves, the radiating element in electrical contact with a sensing surface of the electrodynamic sensor and having a surface area which is larger than a surface area of the sensing surface of the electrodynamic sensor, the antenna located relatively more proximate than the electrodynamic sensor to the individual's skin during operation of the electrode unit a field-sensing mode.

32. An electrode unit according to claim 31 comprising: a spring-biased clamp for attachment of the electrode unit to an individual's clothing when operating in a non-contact field-sensing mode.

33. An electrode unit according to claim 31 comprising an attachment means for physical and electrical attachment of the electrode unit to a resistive sensor element when operating in a resistive mode.

34. An electrode unit according to claim 31 wherein the electrical activity monitoring system comprises an ECG system, EEG system, EOG system, or EMG system.

35. An electrode unit according to claim 31 wherein the capacitive sensor element comprises an electrically non-conductive layer disposed on the radiating element, wherein the non-conductive layer is on an outside face of the electrode unit which is located relatively more proximate than the radiating element to the individual's skin during operation of the electrode unit in the field-sensing mode.

36. An electrode unit according to claim 35 wherein the electrically non-conductive layer comprises a metallization layer electrically connected to an inner metallization layer in direct electrical contact with the electrodynamic sensor.

37. An electrode unit according to claim 36 comprising an insulator layer to provide compressive force and facilitate proper the direct electrical contact between the metallization layer and the inner metallization layer.

38. An electrode unit according to claim 31 comprising a distal component to provide electrical noise shielding.

39. An electrode unit according to claim 33 wherein the attachment means comprises a first connector component for

receiving a second complementary connector component of the resistive sensor element for physical and electrical attachment of the electrode unit to the resistive sensor element by connecting the first and second connector components.

40. An electrode unit according to claim 34 wherein the first and second connector components are shaped such that connecting the first and second connector components causes deformation of at least one of the first and second connector components and corresponding restorative forces which tend to maintain the connection between the first and second connector components.

41. An electrode unit according to claim 33 wherein the attachment means comprises a first connector component for receiving a second complementary connector component of the resistive sensor element for physical and electrical attachment of the electrode unit to the resistive sensor element by connecting the first and second connector components and wherein the first connector component is located on a side of the electrodynamic sensor opposite that of the antenna.

42. An electrode unit according to claim 33 wherein the attachment means comprises the clamp, the clamp comprising a pair of clamp teeth configured to hold a portion of a resistive sensor element therebetween.

43. An electrode unit according to claim 32 wherein the clamp comprises one or more electrically conducting clamp contacts located in one or both of the teeth for providing electrical contact to the resistive sensor element.

44. An electrode unit according to claim 31 wherein the electrode unit is incorporated into a vehicle.

45. An electrode unit according to claim 44 wherein the electrode unit is in wireless communication with a head unit of the vehicle and communicates information about the electric field to the head unit.

46. An electrode unit according to claim 31 wherein the electrode unit is incorporated into a seat or a steering control of the vehicle.

47. A method for sensing physiological electrical activity of an individual comprising:

providing a first electrode unit for generating a first signal indicative of the electrical activity at a first location on a body of the individual;

providing a second electrode unit for generating a second signal indicative of the electrical activity at a second location on the body of the individual;

operating the first electrode unit and second electrode unit in field-sensing mode to generate the first signal and the second signal; and

using the first signal and the second signal to generate one or more waveforms indicative of the electrical activity, wherein each of the electrode units comprises a capacitive sensor element, and the capacitive sensor element of each of the electrode units comprises:

an electrodynamic sensor which is sensitive to electromagnetic waves; and

an antenna comprising an electrically conductive radiating element for receiving electromagnetic waves, the radiating element in electrical contact with a sensing surface of the electrodynamic sensor and having a surface area which is larger than a surface area of the sensing surface of the electrodynamic sensor, the antenna located relatively more proximate than the electrodynamic sensor to the individual's skin during operation of the electrode unit in field-sensing mode.

专利名称(译)	用于感测生理电活动的电极单元		
公开(公告)号	<a href="#">US20150005608A1</a>	公开(公告)日	2015-01-01
申请号	US14/459142	申请日	2014-08-13
申请(专利权)人(译)	EASYG LLC		
当前申请(专利权)人(译)	EASYG LLC		
[标]发明人	EVANS THOMAS CRANNELL GAVRILOVICH EFRAIM MIHAI RASVAN CATALIN ISBASESCU ION		
发明人	EVANS, THOMAS CRANNELL GAVRILOVICH, EFRAIM MIHAI, RASVAN CATALIN ISBASESCU, ION		
IPC分类号	A61B5/0478 A61B5/0492 A61B5/02 A61B5/16 A61B5/0452 A61B5/0416 A61B5/0408 A61B5/08 A61B5/04 A61B5/00 A61B5/044 A61B5/18 A61B5/0496		
CPC分类号	A61B5/18 A61B5/6893 A61B5/0478 A61B5/0496 A61B5/0492 A61B5/7203 A61B5/6843 A61B5/6804 A61B5/0416 A61B5/04012 A61B5/0006 A61B5/044 A61B5/4809 A61B5/0452 A61B5/02042 A61B5/165 A61B5/08 A61B5/04085 A61B5/0428 A61B5/6831 A61B2562/0214		
优先权	14/377255 2014-08-07 US PCT/US2013/025432 2013-02-08 WO 61/596543 2012-02-08 US		
其他公开文献	US10182723		
外部链接	<a href="#">Espacenet</a> <a href="#">USPTO</a>		

摘要(译)

用于监测个体的生理电活动的系统和装置包括：第一电极单元，用于接收指示个体身体上的第一位置处的电活动的第一信号；以及第二电极单元，用于接收指示电活动的第二信号。个人身体上的第二个位置。第一和第二电极单元中的每一个可以以场感测模式操作，其中电极单元放置在个体皮肤上或附近。第一和第二电极单元包括电容传感器元件，并且每个电极单元的电容传感器元件包括对电磁波敏感的电动传感器；天线包括用于接收电磁波的导电辐射元件。场感测模式可以是非接触场感测模式，其中电极单元放置在个人的衣服上，或者是接触场感测模式，其中电极单元直接放置在个人的皮肤上。

