



US010390749B2

(12) **United States Patent**
Zhang et al.

(10) **Patent No.:** **US 10,390,749 B2**
(45) **Date of Patent:** **Aug. 27, 2019**

(54) **METHOD AND DEVICE FOR MONITORING FATIGUED DRIVING**

(71) Applicant: **BOE TECHNOLOGY GROUP CO., LTD.**, Beijing (CN)

(72) Inventors: **Jingyu Zhang**, Beijing (CN); **Wei Sun**, Beijing (CN)

(73) Assignee: **BOE TECHNOLOGY GROUP CO., LTD.**, Beijing (CN)

(*) Notice: Subject to any disclaimer, the term of this patent is extended or adjusted under 35 U.S.C. 154(b) by 23 days.

(21) Appl. No.: **15/510,854**

(22) PCT Filed: **Feb. 23, 2016**

(86) PCT No.: **PCT/CN2016/074316**

§ 371 (c)(1),
(2) Date: **Mar. 13, 2017**

(87) PCT Pub. No.: **WO2016/161850**

PCT Pub. Date: **Oct. 13, 2016**

(65) **Prior Publication Data**

US 2017/0281068 A1 Oct. 5, 2017

(30) **Foreign Application Priority Data**

Apr. 10, 2015 (CN) 2015 1 0170673

(51) **Int. Cl.**
A61B 5/18 (2006.01)
G08B 21/06 (2006.01)

(Continued)

(52) **U.S. Cl.**
CPC **A61B 5/18** (2013.01); **A61B 3/10** (2013.01); **A61B 5/0077** (2013.01); **A61B 5/022** (2013.01);

(Continued)

(58) **Field of Classification Search**

CPC B60W 2040/0827
See application file for complete search history.

(56) **References Cited**

U.S. PATENT DOCUMENTS

6,575,902 B1 * 6/2003 Burton A61B 5/18
340/575
2007/0100666 A1 * 5/2007 Stivoric F24F 11/30
705/3

(Continued)

FOREIGN PATENT DOCUMENTS

CN 2693220 Y 4/2005
CN 2822608 Y 10/2006

(Continued)

OTHER PUBLICATIONS

Search Report and Written Opinion dated May 27, 2016 from State Intellectual Property Office of the P.R. China.

(Continued)

Primary Examiner — Scott Luan

(74) *Attorney, Agent, or Firm* — Dilworth & Barrese, LLP; Michael J. Musella, Esq.

(57) **ABSTRACT**

A method and device for monitoring fatigued driving. The device comprises a processor, a monitoring unit an alarm unit and an inflating unit connected to the processor. The processor is used to obtain a monitor result, transmit, according to the monitor result, an alarm instruction to the alarm unit, and transmit an air inflation instruction to inflating unit upon obtaining the monitor result again after transmitting the alarm instruction. The monitor unit is used to monitor, in real time, a driving state of the driver, and transmit data indicating the driving state of the driver; the alarm unit (12) is used to receive the alarm instruction, and provide the alarm according to the alarm instruction; and the

(Continued)

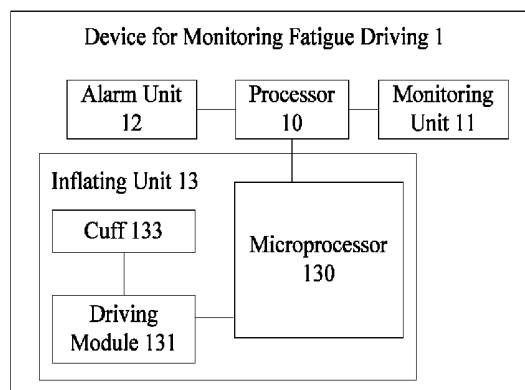

inflating unit is used to receive the air inflation instruction, and fill air according to the air inflation instruction. (56)

17 Claims, 6 Drawing Sheets

- (51) **Int. Cl.**
A61B 3/10 (2006.01)
A61B 5/022 (2006.01)
A61B 5/0476 (2006.01)
A61M 21/00 (2006.01)
A61B 5/00 (2006.01)
A61B 5/11 (2006.01)
A61B 5/01 (2006.01)
A61B 5/048 (2006.01)
B60K 28/06 (2006.01)
B60W 40/08 (2012.01)
- (52) **U.S. Cl.**
 CPC *A61B 5/0476* (2013.01); *A61B 5/1103* (2013.01); *A61M 21/00* (2013.01); *G08B 21/06* (2013.01); *A61B 5/01* (2013.01); *A61B 5/048* (2013.01); *A61B 5/7282* (2013.01); *A61B 2560/029* (2013.01); *A61B 2562/0219* (2013.01); *B60K 28/066* (2013.01); *B60W 2040/0827* (2013.01)

References Cited

U.S. PATENT DOCUMENTS

2010/0134302 A1 6/2010 Ahn et al.
 2015/0008710 A1* 1/2015 Young B60N 2/914
 297/217.3

FOREIGN PATENT DOCUMENTS

CN	103111020 A	5/2013
CN	103318023 A	9/2013
CN	203318275 U	12/2013
CN	203338530 U	12/2013
CN	103680065 A	3/2014
CN	103818256 A	5/2014
CN	102274032 A	12/2014
CN	104505922 A	4/2015
CN	204390429 U	6/2015
CN	104840204 A	8/2015
JP	201099143 A	5/2010

OTHER PUBLICATIONS

Chinese Office Action dated Dec. 28, 2016.
 Second Chinese Office Action dated Jun. 16, 2017.

* cited by examiner

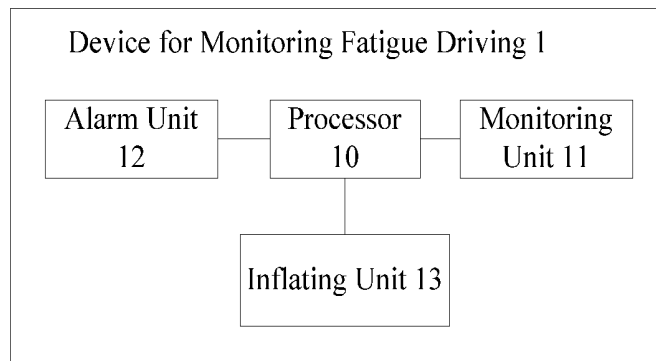

FIG. 1

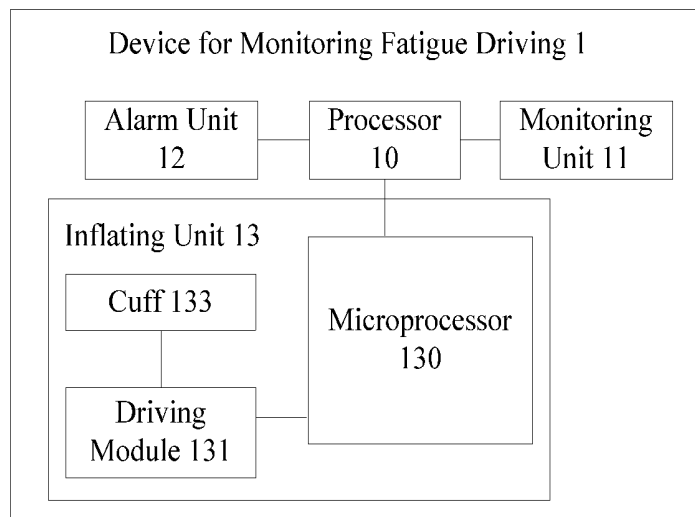

FIG. 2

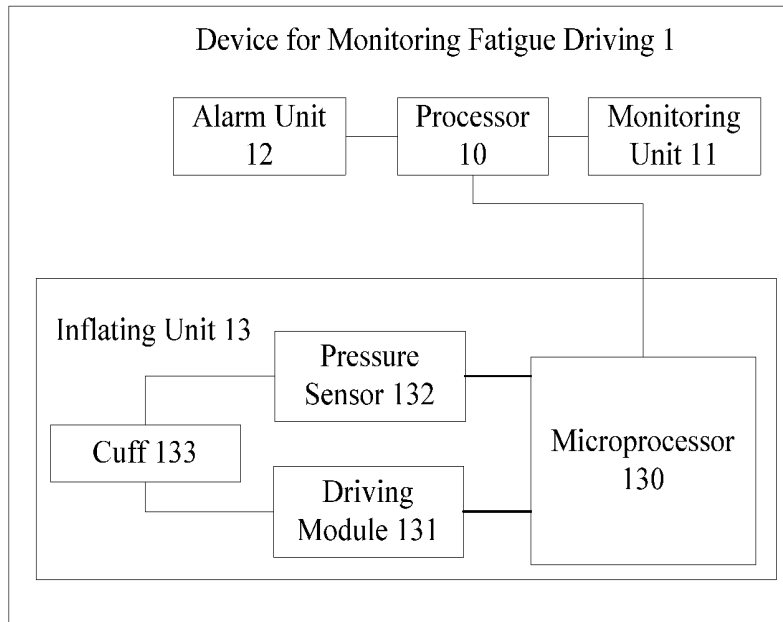

FIG. 3

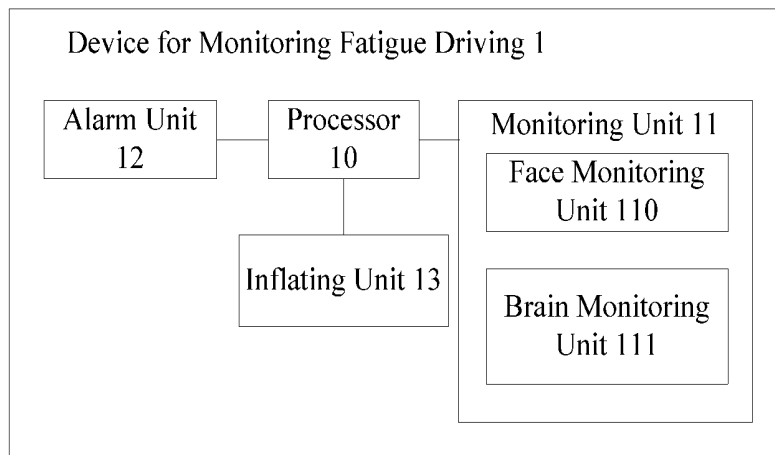

FIG. 4

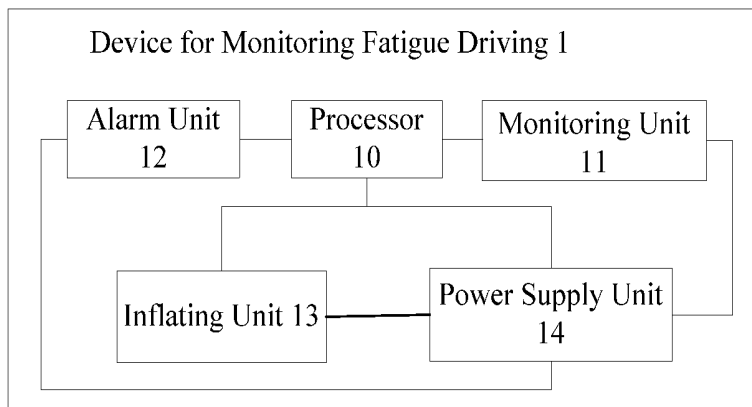

FIG. 5

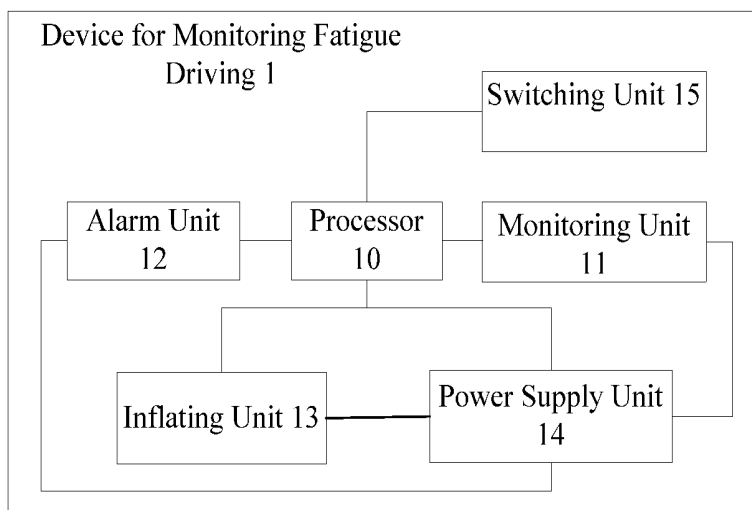

FIG. 6

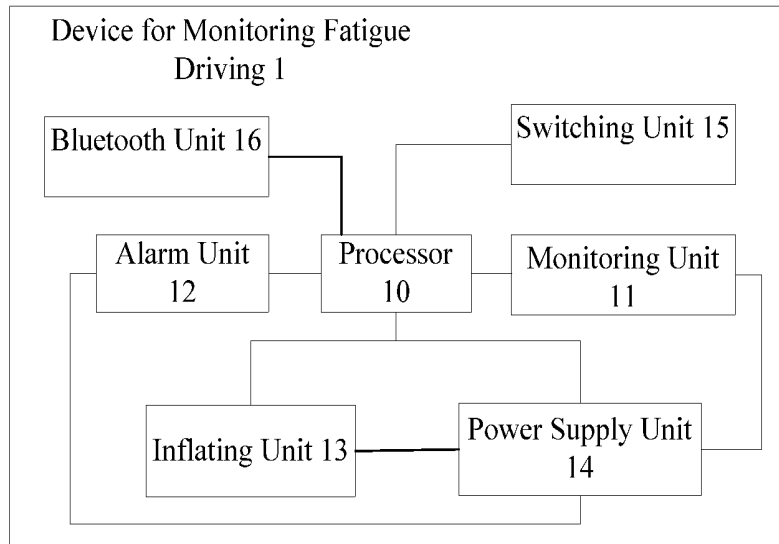

FIG. 7

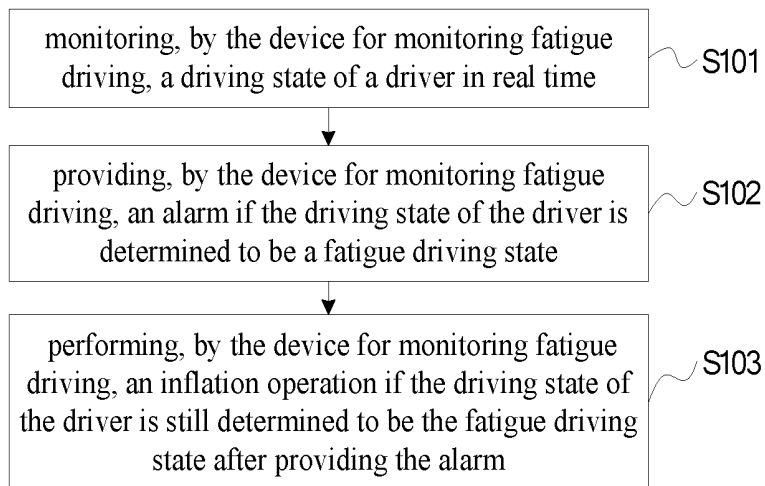

FIG. 8

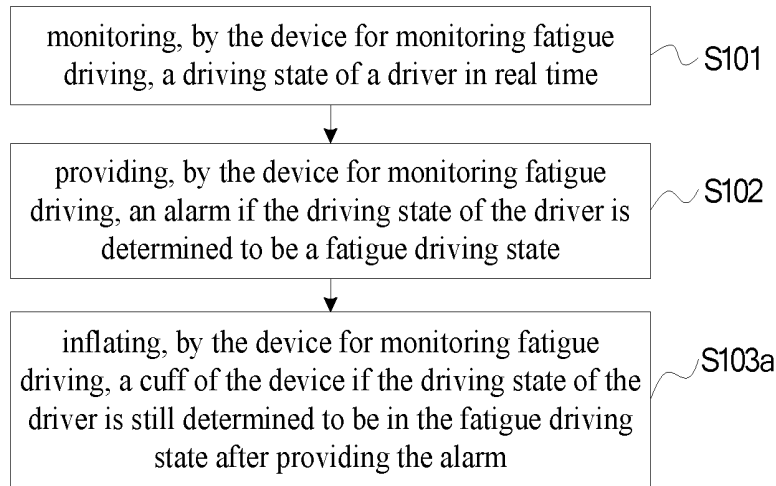

FIG. 9

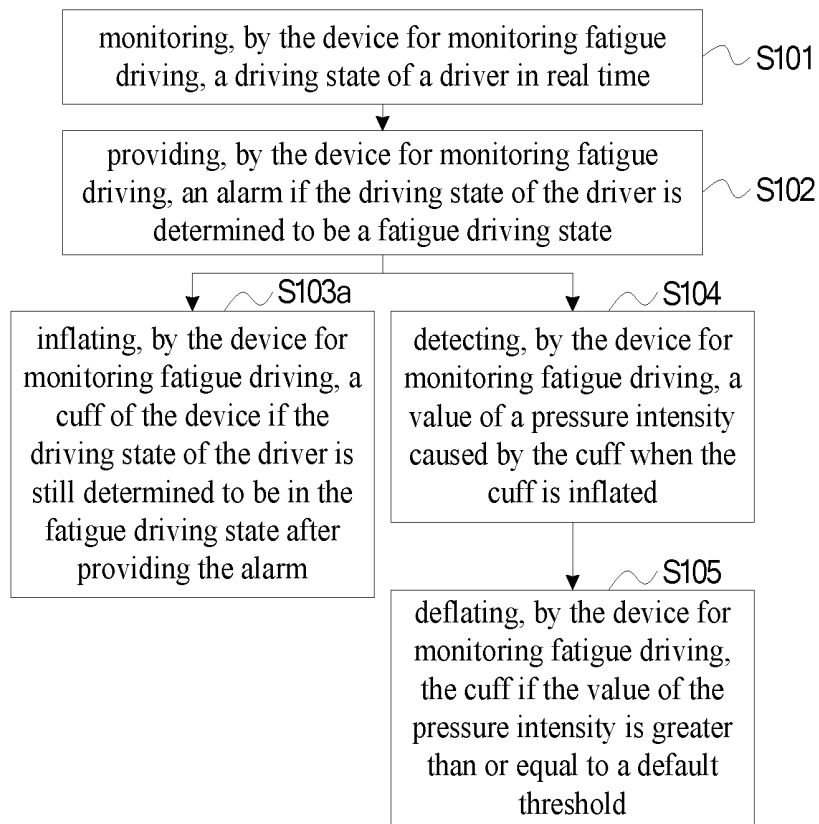

FIG. 10

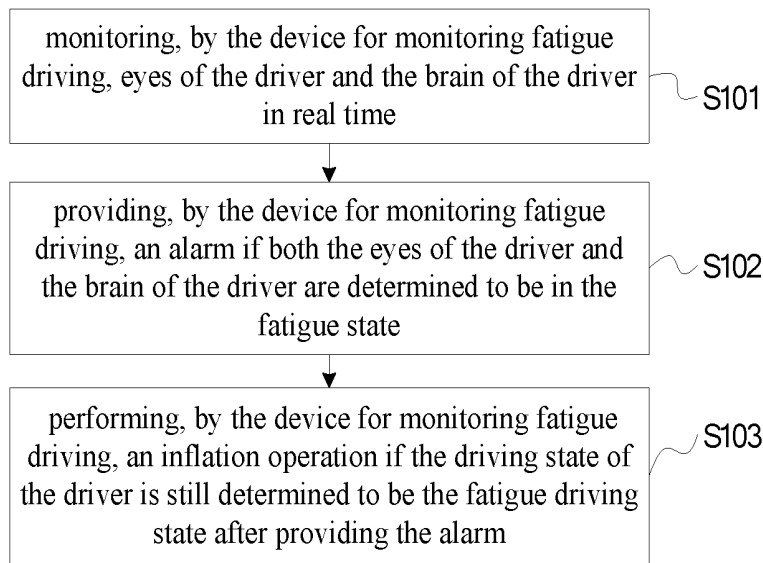

FIG. 11

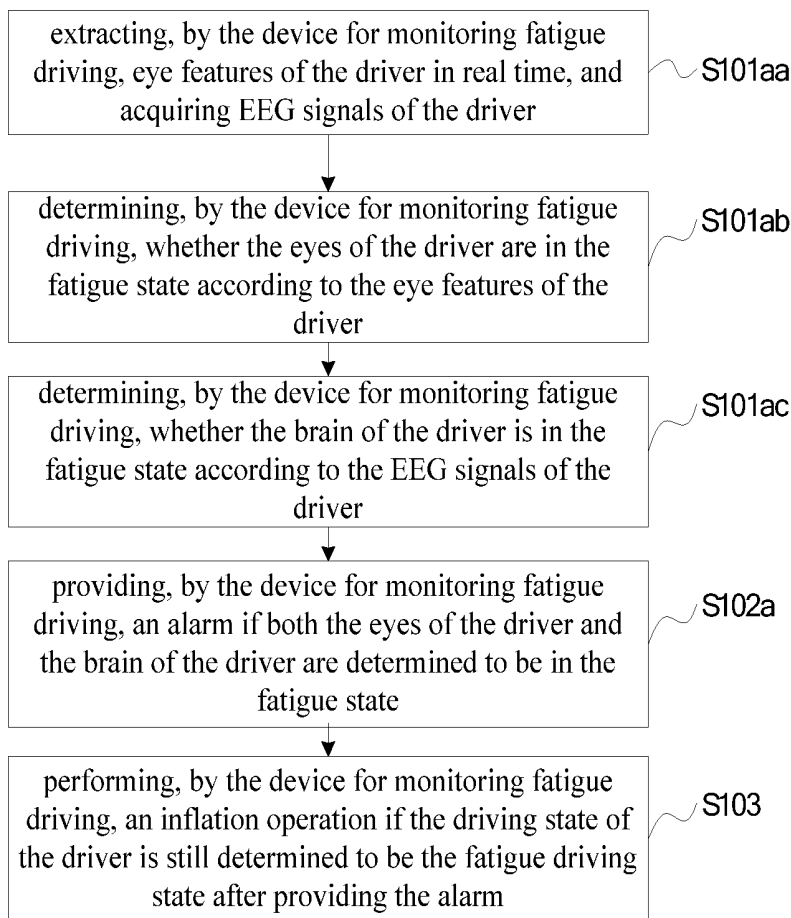

FIG. 12

METHOD AND DEVICE FOR MONITORING FATIGUED DRIVING

TECHNICAL FIELD

Embodiments of the present disclosure relate to a method and device for monitoring fatigue driving.

BACKGROUND

It is well-known that fatigue driving is one of the major factors that cause most traffic accidents, and so how to prevent fatigue driving has gradually become a focus of attention.

A fatigue driving warning system in existing technologies can only give out a simple warning to a driver when it detects that the driver is in a fatigue driving state. However, when the driver is in an over-fatigue state, the warning may not be able to effectively help the driver to restore from the fatigue driving state to a clearheaded driving state, such that safety problems that may emerge when the driver is in the fatigue driving state still cannot be effectively avoided.

SUMMARY

Embodiments of the present disclosure provide a method and a device for monitoring fatigue driving, which can increase a probability that the driver restores from a fatigue driving state to a clearheaded driving state, and hence can reduce a probability of occurrence of safety problems when the driver is in the fatigue driving state.

Embodiments of the disclosure provides a device for monitoring fatigue driving, which includes a processor, and a monitoring unit, an alarm unit and an inflating unit which are respectively connected with the processor. For example, the processor is configured to acquire a monitoring result, send an alarm instruction to the alarm unit according to the monitoring result, and send an inflating instruction to the inflating unit when acquiring the monitoring result again after sending the alarm instruction, where the monitoring result is used for indicating whether a driver is in a fatigue driving state, the alarm instruction is used for instructing the alarm unit to give out an alarm, and the inflating instruction is used for instructing the inflating unit to perform an inflation operation; the monitoring unit is configured to monitor the driving state of the driver in real time, and send data indicating the driving state of the driver to the processor; the alarm unit is configured to receive the alarm instruction sent by the processor, and give out the alarm according to the alarm instruction; and the inflating unit is configured to receive the inflating instruction sent by the processor, and perform the inflation operation according to the inflating instruction.

For example, the inflating unit includes a microprocessor connected with the processor, a driving module connected with the microprocessor, and a cuff connected with the driving module. The microprocessor is configured to receive the inflating instruction sent by the processor, and send an inflating signal to the driving module according to the inflating instruction; and the driving module is configured to receive the inflating signal sent by the microprocessor, and inflate the cuff according to the inflating signal.

For example, the inflating unit further includes a pressure sensor connected with both the microprocessor and the cuff. The pressure sensor is configured to detect a value of a pressure intensity of the cuff when the driving module inflates the cuff, and send the value of the pressure intensity

to the microprocessor; the microprocessor is also configured to receive the value of the pressure intensity sent by the pressure sensor, and send a deflating signal to the driving module when the value of the pressure intensity is greater than or equal to a default threshold; and the driving module is also configured to receive the deflating signal sent by the microprocessor, and deflate the cuff according to the deflating signal.

For example, the driving module is a miniature inflation motor; or the driving module includes a miniature pressure pump and a miniature exhaust valve.

For example, the monitoring unit includes at least one of a face monitoring module or a brain monitoring module; the face monitoring module is configured to monitor eyes of the driver and send data indicating an eye state of the driver to the processor; and the brain monitoring module is configured to monitor a brain of the driver and send data indicating a brain state of the driver to the processor.

For example, the face monitoring module is a miniature camera; and the brain monitoring module is an electroencephalogram (EEG) sensor.

For example, the device for monitoring fatigue driving further comprises a power supply unit connected with the processor, the monitoring unit, the alarm unit and the inflating unit; and the power supply unit is configured to supply power for the processor, the monitoring unit, the alarm unit and the inflating unit.

For example, the power supply unit is charged by a wireless charging approach.

For example, the device for monitoring fatigue driving further comprises a switching unit connected with the processor; and the switching unit is configured to control the device for monitoring fatigue driving to switch on or off.

For example, the switching unit is a mechanical switch or an acceleration sensor.

For example, the alarm unit includes at least one of a voice alarm module or a vibrating motor alarm module.

Embodiments of the disclosure provide a method for monitoring fatigue driving, applied in a device for monitoring fatigue driving described herein, which includes: monitoring, by the device for monitoring fatigue driving, a driving state of a driver in real time; providing, by the device for monitoring fatigue driving, an alarm if the driving state of the driver is determined to be a fatigue driving state; and performing, by the device for monitoring fatigue driving, an inflation operation if the driving state of the driver is still determined to be the fatigue driving state after providing the alarm.

For example, performing, by the device for monitoring fatigue driving, the inflation operation if the driving state of the driver is still determined to be the fatigue driving state after providing the alarm includes: inflating a cuff of the device for monitoring fatigue driving if the driving state of the driver is still determined to be the fatigue driving state after providing the alarm.

For example, the method further comprises: detecting, by the device for monitoring fatigue driving, a value of a pressure intensity of the cuff when the cuff is inflated; and deflating the cuff if the value of the pressure intensity is greater than or equal to a default threshold.

For example, monitoring, by the device for monitoring fatigue driving, the driving state of a driver in real time includes: monitoring, by the device for monitoring fatigue driving, eyes of the driver and a brain of the driver in real time; and performing, by the device for monitoring fatigue driving, the inflation operation if the driving state of the driver is still determined to be the fatigue driving state after

providing the alarm includes: providing, by the device for monitoring fatigue driving, the alarm if both the eyes of the driver and the brain of the driver are determined to be in a fatigue state.

For example, monitoring, by the device for monitoring fatigue driving, the eyes of the driver and the brain of the driver in real time includes: extracting, by the device for monitoring fatigue driving, eye features of the driver in real time, and acquiring an EEG signal of the driver; determining, by the device for monitoring fatigue driving, whether the eyes of the driver are in the fatigue state according to the eye features; and determining, by the device for monitoring fatigue driving, whether the brain of the driver is in the fatigue state according to the EEG signal.

BRIEF DESCRIPTION OF THE DRAWINGS

In order to illustrate the technical solutions in the embodiments of the present disclosure or the existing arts more clearly, the drawings need to be used in the description of the embodiments or the existing arts will be briefly described in the following; it is obvious that the drawings described below are only related to some embodiments of the present disclosure, for one ordinary skilled person in the art, other drawings can be obtained according to these drawings without making other inventive work.

FIG. 1 is a first schematic structural view of a device for monitoring fatigue driving provided by an embodiment of the present disclosure;

FIG. 2 is a second schematic structural view of a device for monitoring fatigue driving provided by an embodiment of the present disclosure;

FIG. 3 is a third schematic structural view of a device for monitoring fatigue driving provided by an embodiment of the present disclosure;

FIG. 4 is a fourth schematic structural view of a device for monitoring fatigue driving provided by an embodiment of the present disclosure;

FIG. 5 is a sixth schematic structural view of a device for monitoring fatigue driving provided by an embodiment of the present disclosure;

FIG. 6 is a sixth schematic structural view of a device for monitoring fatigue driving provided by an embodiment of the present disclosure;

FIG. 7 is a seventh schematic structural view of a device for monitoring fatigue driving provided by an embodiment of the present disclosure;

FIG. 8 is a first flowchart of a method for monitoring fatigue driving provided by an embodiment of the present disclosure;

FIG. 9 is a second flowchart of a method for monitoring fatigue driving provided by an embodiment of the present disclosure;

FIG. 10 is a third flowchart of a method for monitoring fatigue driving provided by an embodiment of the present disclosure;

FIG. 11 is a fourth flowchart of a method for monitoring fatigue driving provided by an embodiment of the present disclosure; and

FIG. 12 is a fifth flowchart of a method for monitoring fatigue driving provided by an embodiment of the present disclosure.

DETAILED DESCRIPTION

Hereafter, the technical solutions of the embodiments of the present disclosure will be described in a clearly and fully

understandable way in connection with the drawings related to the embodiments of the disclosure. It is obvious that the described embodiments are just a part but not all of the embodiments of the present disclosure. Based on embodiments of the present disclosure, all other embodiments obtained by those skilled in the art without making other inventive work should be within the scope of the present disclosure.

Detailed description will be given below to a method and a device for monitoring fatigue driving, provided by embodiments of the present disclosure, with reference to the accompanying drawings.

In some technical solutions, a device for monitoring fatigue driving (or a warning system for fatigue driving) comprises a central processing unit (CPU), a fatigue driving warning light, a voice reminder, a hand blood pressure sensor, a foot blood pressure sensor and a body temperature sensor which are electrically connected with the CPU respectively, and a power source for supplying power to the various power consumption components described above. The device (or the system) may monitor life parameters, including a time duration when a driver sits on a driver seat, a body temperature of the driver, a hand blood pressure and a foot blood pressure, etc., in real time. The life parameters may reflect a current physical status of the driver in real time. For instance, the hand blood pressure and the foot blood pressure may indicate whether the driver has insufficient blood pressure and whether hand and/or foot paralysis occurs. After the CPU collects and analyzes the life parameters, the fatigue driving warning light and the voice reminder may provide a warning message to the driver so that a warning indicating whether the driver has been in the fatigue driving state may be provided in time to the driver, and another warning indicating possible occurrence of paroxysmal diseases may also be provided to the driver.

As illustrated in FIG. 1, an embodiment of the present disclosure provides a device 1 for monitoring fatigue driving. The device 1 for monitoring fatigue driving may comprise a processor 10, a monitoring unit 11, an alarm unit 12 and an inflating unit 13, where the monitoring unit 11, the alarm unit 12 and the inflating unit 13 are respectively connected to the processor 10.

For instance, the processor 10 is configured to acquire a monitoring result, send an alarm instruction to the alarm unit 12 according to the monitoring result, and send an inflating instruction to the inflating unit 13 when acquiring the monitoring result again after sending the alarm instruction, in which the monitoring result indicates whether the driver is in the fatigue driving state, the alarm instruction is used for instructing the alarm unit 12 to provide an alarm signal; and the inflating instruction is used for instructing the inflating unit 13 to perform an inflating operation.

The monitoring unit 11 is configured to monitor in real time or in near real time a driving state of the driver, and send data indicating the driving state of the driver to the processor 10.

The alarm unit 12 is configured to receive the alarm instruction sent by the processor 10, and provide an alarm signal according to the alarm instruction. For instance, the alarm signal may include a voice prompt, a lighting alert or a vibrating alert.

The inflating unit 13 is configured to receive the inflating instruction sent by the processor 10, and perform an inflating operation according to the inflating instruction.

The device for monitoring fatigue driving provided by embodiments of the present disclosure may monitor the driving state of the driver in real time, may prompt the driver

through the alarm signal when the driver is in the fatigue driving state, and may also perform an inflating operation when the driver continues to be in the fatigue driving state. The inflating operation helps the driver to restore from the fatigue driving state to a clearheaded driving state. The device for monitoring fatigue driving provided by embodiments of the present disclosure can increase a probability that the driver restores from the fatigue driving state to the clearheaded driving state, and hence can reduce a probability of occurrence of safety problems when the driver is in the fatigue driving state.

It is noted that the device for monitoring fatigue driving provided by the embodiments of the present disclosure may be worn on the driver's head. When the inflating unit **13** performs an inflating operation, gas introduced by the inflating unit may apply pressure on the driver's head and help to increase the amount of blood supply on the driver's head, which is helpful for the driver to restore from the fatigue driving state to the clearheaded driving state.

For instance, the device for monitoring fatigue driving provided by the embodiments of the present disclosure may be a small-sized monitoring device which can be worn on the driver's head, e.g., a hat, a headphone, a barrette and a hair lace, etc.

For instance, a method of acquiring the monitoring result by the processor **10** in the embodiments of the present disclosure may include any of the following:

(1) The processor **10** receives the monitoring result sent by the monitoring unit **11**. For instance, the data indicating the driving state of the driver, sent by the monitoring unit **11** to the processor **10**, is the monitoring result. For instance, the processor **10** directly receives the monitoring result sent by the monitoring unit **11**. In another instance, the monitoring unit **11** monitors the driving state of the driver in real time and may send the obtained monitoring result to the processor **10** when the driver is in the fatigue driving state, and the processor **10** may provide an alarm instruction according to the monitoring result after acquiring the monitoring result.

(2) After receiving the data indicating the driving state of the driver sent by the monitoring unit **11**, the processor **10** analyzes and processes the data and obtains a processing result, and then acquires the monitoring result from the processing result. For instance, the data indicating the driving state of the driver, sent by the monitoring unit **11** to the processor **10**, is data relevant to the driver including, e.g., eye features, facial features and/or electroencephalograph (EEG) signals of the driver monitored in real time by the monitoring unit **11**. The processing result may include a first monitoring result indicating that the driver is in the fatigue driving state or a second monitoring result indicating that the driver is in the clearheaded driving state (is not in the fatigue driving state). In embodiments of the present disclosure, after the processor **10** obtains the processing result, if the processing result is the second monitoring result, the processor **10** may not take any action; and if the processing result is the first monitoring result, the processor **10** may provide an alarm instruction according to the first monitoring result after acquiring the first monitoring result.

For instance, as shown in FIG. 2, the inflating unit **13** may include a microprocessor **130** connected with the processor **10**, a driving module **131** connected with the microprocessor **130**, and a cuff **133** connected with the driving module **131**.

For instance, the microprocessor **130** may be configured to receive the inflating instruction sent by the processor **10**, and send an inflating signal to the driving module **131** according to the inflating instruction.

The driving module **131** may be configured to receive the inflating signal sent by the microprocessor **130**, and inflate the cuff **133** according to the inflating signal.

In embodiments of the present disclosure, when the device for monitoring fatigue driving is adopted for monitoring, the cuff **133** may be wound around the driver's head. Thus, when the driving module **131** inflates the cuff **133**, along with the gradually increased pressure intensity of the gas in the cuff **133**, the cuff **133** may impose pressure on the driver's head, which is helpful for increasing the amount of blood supply on the driver's head. Therefore, it is helpful for the driver to restore from the fatigue driving state to the clearheaded driving state.

For instance, as shown in FIG. 3, the inflating unit **13** may also include a pressure sensor **132** connected with both the microprocessor **130** and the cuff **133**.

For instance, the pressure sensor **132** may be configured to detect a value of a pressure intensity of the cuff **133** when the driving module **131** inflates the cuff **133**, and send the value of the pressure intensity to the microprocessor **130**.

The microprocessor **130** is also configured to receive the value of the pressure intensity sent by the pressure sensor **132**, and send a deflating signal to the driving module **131** when the pressure intensity is greater than or equal to a default threshold.

The driving module **131** is also configured to receive the deflating signal sent by the microprocessor **130**, and deflate the cuff **133** according to the deflating signal.

In embodiments of the present disclosure, the driving module **131** in the inflating unit **13** may inflate the cuff **133**, so that the pressure intensity in the cuff **133** can be gradually increased. That is, the cuff **133** can apply pressure to the driver's brain, which is helpful for increasing the amount of blood supply on the driver's head, and hence it is helpful for the driver to restore from the fatigue driving state to the clearheaded driving state.

Moreover, when the driving module **131** inflates the cuff **133**, in order to prevent the cuff **133** from applying too much pressure to the driver's head and prevent the driver's head from being overly oppressed, the pressure sensor **132** may detect a value of the pressure intensity of the cuff **133** in real time and send the value of the pressure intensity to the microprocessor **130**. The microprocessor **130** can compare the value of the pressure intensity with a default threshold (that is, a predetermined maximal pressure intensity applied to the cuff). If the microprocessor **130** determines that the value of the pressure intensity is greater than or equal to the default threshold, the microprocessor **130** may send the deflating signal to the driving module **131** and control the driving module **131** to deflate the cuff **133**, so as to reduce the pressure applied to the driver's head by the cuff **133**, and hence the brain of the driver may not be overly oppressed.

For instance, the default threshold may be set according to actual design demands of the inflating unit. No specific limitation will be given here in embodiments of the present disclosure.

For instance, in embodiments of the present disclosure, after the driving module **131** inflates the cuff **133** which is helpful for the driver to restore from the fatigue driving state to the clearheaded driving state, the microprocessor **130** may also send the deflating signal to the driving module **131** after a preset time and instruct the driving module **131** to deflate the cuff **133**, so as to avoid the problem that the driver's head is overly oppressed due to overlarge pressure caused by the cuff **133** on the brain of the driver when the driver is in the clearheaded driving state.

An implementation principle of the inflating unit **13** in embodiments of the present disclosure is similar to an implementation principle of inflating in a process of measuring blood pressure via an electronic sphygmomanometer; that is, a cuff being worn around an arm of a user to be tested is inflated, so that the cuff can impose certain pressure to the user's arm. For instance, the implementation principle of the inflating unit **13** may be understood with reference to the implementation principle of inflating in the process of measuring blood pressure via an electronic sphygmomanometer. No further description will be given here.

For instance, in a feasible implementation, the driving module **131** in embodiments of the present disclosure may be a miniature inflation motor. As the miniature inflation motor not only can inflate the cuff **133** but also can deflate the cuff **133**, the driving module **131** may be implemented by one miniature inflation motor.

For instance, in another feasible implementation, the driving module **131** in embodiments of the present disclosure may include a miniature pressure pump and a miniature exhaust valve. As the miniature pressure pump inflates the cuff **133** and the miniature exhaust valve deflates the cuff **133**, the driving module **131** may be implemented by one miniature pressure pump and one miniature exhaust valve together.

It is noted that the miniature inflation motor, the miniature pressure pump and the miniature exhaust valve in embodiments of the present disclosure may all be selected as components with a small size, so as to prevent the inflating unit and the device for monitoring fatigue driving from interfering with normal driving of the driver.

For instance, the monitoring unit **11** may include at least one of a face monitoring module **110** or a brain monitoring module **111**.

For instance, the face monitoring module **110** may be configured to monitor the eyes of the driver, and send data indicating a state of the eyes of the driver to the processor **10**.

The brain monitoring module **111** may be configured to monitor the brain of the driver, and send data indicating a brain state of the driver to the processor **10**.

It is noted that: when the monitoring unit **11** includes the face monitoring module **110**, the data indicating the driving state of the driver sent by the monitoring unit **11** to the processor **10** includes data indicating a facial state of the driver (for instance, the data indicating the facial state may include data indicating the eye state). When the monitoring unit **11** includes the brain monitoring module **111**, the data indicating the driving state of the driver sent by the monitoring unit **11** to the processor **10** may include data indicating the brain state of the driver. When the monitoring unit **11** includes the face monitoring module **110** and the brain monitoring module **111**, the data indicating the driving state of the driver sent by the monitoring unit **11** to the processor **10** includes data indicating the facial state of the driver, data indicating the eye state of the driver, data indicating the brain state of the driver or any combination thereof.

Correspondingly, the monitoring result includes a face monitoring result corresponding to the face monitoring module **110** and a brain monitoring result corresponding to the brain monitoring module **111**. The face monitoring result is used for indicating that the face and/or the eyes of the driver are in the fatigue state, and the brain monitoring result is used for indicating that the brain of the driver is in the fatigue state.

For instance, when the monitoring unit **11** includes the face monitoring module **110**, the monitoring result which

can be acquired by the processor **10** includes the face monitoring result; when the monitoring unit **11** includes the brain monitoring module **111**, the monitoring result which can be acquired by the processor **10** includes the brain monitoring result; and when the monitoring unit **11** includes the face monitoring module **110** and the brain monitoring module **111**, the monitoring result which can be acquired by the processor **10** includes the face monitoring result and the brain monitoring result.

For instance, with reference to FIG. 1, the monitoring unit **11** as shown in FIG. 4 in embodiments of the present disclosure may be implemented by the face monitoring module **110** and the brain monitoring module **111** together. For instance, the eye state of the driver may be monitored by the face monitoring module **110** and simultaneously the brain state of the driver may be monitored by the brain monitoring module **111**, so that whether the driver is in the fatigue driving state may be determined according to the driver's state monitored by the two monitoring modules including the face monitoring module **110** and the brain monitoring module **111**. Hence, the monitoring accuracy of the device for monitoring fatigue driving can be improved.

For instance, the face monitoring module **110** may be a miniature camera, and the brain monitoring module **111** may be an EEG sensor. For instance, the miniature camera may monitor the eye state of the driver in real time by extracting eye features of the driver. The miniature camera may also monitor the facial state of the driver in real time by extracting facial features of the driver. The EEG sensor may monitor the brain state of the driver in real time by acquiring EEG signals of the driver.

In some embodiments, the face monitoring module **110** may be implemented by a miniature camera and may also be achieved by other component/apparatus/devices capable of capturing the eye features of the driver. No specific limitation will be given in the present disclosure. An EEG sensor may also be selected according to actual design demands of the device for monitoring fatigue driving. No specific limitation will be given in the present disclosure.

It is noted that the miniature camera, the EEG sensor and the like may be selected as components with small sizes, so as to prevent the monitoring unit and the device for monitoring fatigue driving from interfering with normal driving of the driver.

In embodiments of the present disclosure, the miniature camera for implementing the face monitoring module **110** may capture the eye features of the driver by using camera-capture technologies, so that whether the eyes of the driver are in the fatigue state can be determined according to the eye features. For instance, the miniature camera may take pictures capturing eyes of the driver. The pictures may reflect physiological changes of the driver, that is, the changes of the eye features of the driver, e.g., an amplitude of wink, a frequency of wink, and an average eye closing time of the driver, etc. The miniature camera or the processor may determine whether the eyes of the driver are in the fatigue state by analyzing the eye features of the driver in the pictures.

Of course, the miniature camera for implementing the face monitoring module **110** in embodiments of the present disclosure may also monitor the facial features, eye signals, head movement characteristics and the like of the driver, and can also determine whether the driver is in the fatigue driving state by synthesizing all the information. The specific monitoring method is similar to the method of monitoring the eye features of the driver via the miniature camera. No further description will be given here.

It is noted that the implementation principle of the EEG sensor is similar to a general electrocardiogram (ECG) monitoring principle, and both utilize electrodes to monitor voltage variations. For instance, a neuronal activity of the brain is transmitted to a cerebral cortex through ions to form weak electric signals; after sensing the weak electric signals, the electrodes in the EEG sensor may perform differential amplification, filtering, digital-to-analog conversion and the like on the weak electric signals, so as to convert the weak electric signals into initial data of EEG. Thus, the EEG sensor or the processor can determine whether the brain of the driver is in the fatigue state by analyzing the initial data of EEG.

For instance, in embodiments of the present disclosure, the EEG sensor for implementing the brain monitoring module 111 or the processor may determine whether the brain of the driver is in the fatigue state by adoption of an EEG fatigue state determination method using independent component analysis (ICA). For instance, the EEG sensor may acquire EEG signals (that is, the initial data of EEG) by the above method, and the EEG sensor or the processor may perform ICA analysis on the acquired EEG signals, calculate a variety of power spectral densities in the EEG, and calculate a fatigue index according to the variety of power spectral densities. When the calculated fatigue index is greater than 1, the brain of the driver may be determined to be in the fatigue state. For instance, the fatigue index may be calculated by the following method.

Illustratively, an EEG signal of a human being may be decomposed into 4 basic rhythms, e.g., a δ wave, a θ wave, an α wave and a β wave, and the 4 rhythms will change along with the change of the fatigue state of the human being. For instance, when the α wave and β wave dominate, it indicates that the consciousness of the human being is clearheaded; but when the δ wave and θ wave dominate, it indicates that the consciousness of the human being is blurred and even is in a slight sleep state. Therefore, whether the brain of the human being is in the fatigue state may be determined and estimated by calculation and analysis of the EEG signals of the human being.

The frequency ranges corresponding to the δ wave, θ wave, α wave and β wave are respectively -3.8 Hz, $4-7.8$ Hz, $8-12.8$ Hz and $13-30$ Hz. Supposing the power spectral density is P and the fatigue index is F , if:

$E_{\delta} = \sum P_i, 1 \leq f(i) \leq 3.8$; $E_{\theta} = \sum P_i, 4 \leq f(i) \leq 7.8$; $E_{\alpha} = \sum P_i, 8 \leq f(i) \leq 12.8$; $E_{\beta} = \sum P_i, 13 \leq f(i) \leq 30$, in which

$$i = 1, 2, 3, \dots, \frac{N}{2}, \text{ and } f = (i) = \frac{f_s i}{N},$$

then

$$F = \frac{E_{\delta} + E_{\theta}}{E_{\alpha} + E_{\beta}}.$$

For instance, as shown in FIG. 5, the device 1 for monitoring fatigue driving provided by embodiments of the present disclosure may further comprise a power supply unit 14 connected with the processor 10, the monitoring unit 11, the alarm unit 12 and the inflating unit 13 respectively.

In some embodiments, the power supply unit 14 is configured to supply power for the processor 10, the monitoring unit 11, the alarm unit 12 and the inflating unit 13.

In embodiments of the present disclosure, as the power supply unit 14 is adopted to supply power for the processor 10, the monitoring unit 11, the alarm unit 12 and the inflating unit 13, it is ensured that the processor 10, the monitoring unit 11, the alarm unit 12 and the inflating unit 13 can all operate normally, so that the device for monitoring fatigue driving provided by embodiments of the present disclosure can accurately monitor the driving state of the driver and perform corresponding operations that match the driving state.

For instance, the power supply unit 14 may be charged by a wireless charging approach, e.g., being charged by a power source mounted on a vehicle. As the power supply unit 14 in embodiments of the present disclosure is charged by a wireless charging approach, interference on the driving of the driver when the power supply unit is charged by a wired approach can be avoided.

For instance, as shown in FIG. 6, the device 1 for monitoring fatigue driving provided by embodiments of the present disclosure may further comprise a switching unit 15 connected with the processor 10. The switching unit 15 may be configured to control the device 1 for monitoring fatigue driving to switch on or off.

It should be understood that: in order to reduce the power consumption of the device for monitoring fatigue driving, the switching unit 15 may be adopted to control the device for monitoring fatigue driving to switch on when the device is used; and the switching unit 15 may be adopted to control the device for monitoring fatigue driving to switch off when the device is not used, so that controllability of the device for monitoring fatigue driving can be achieved.

For instance, the switching unit 15 may be a mechanical switch or an acceleration sensor.

When the switching unit 15 is a mechanical switch, the driver may control the device for monitoring fatigue driving to switch on or off by operating on the mechanical switch. When the switching unit 15 is an acceleration sensor, if the driver is driving a vehicle, the acceleration sensor may determine that the driver is in the driving state by detecting the acceleration of the vehicle, and automatically trigger and switch on the device for monitoring fatigue driving. In the above two ways, the mechanical switch can be easily implemented and also has a lower cost; but the acceleration sensor has better real-time performance and reliability.

For instance, the alarm unit 12 may include at least one of a voice alarm module or a vibrating motor alarm module. For instance, the voice alarm module may be implemented by a loudspeaker; that is, the voice alarm module may provide a voice alarm signal through the loudspeaker. The vibrating motor alarm module may be implemented by a motor; that is, the vibrating motor alarm module may provide a vibrating alarm signal through motor rotation.

For instance, as shown in FIG. 7, the device 1 for monitoring fatigue driving provided by embodiments of the present disclosure may further comprise a Bluetooth unit 16 connected with the processor 10. For instance, the Bluetooth unit 16 may be interactive with other devices. The Bluetooth unit 16 may also include a Bluetooth headset, so that the driver can answer a call during driving. In embodiments of the present disclosure, the Bluetooth unit 16 may be powered by batteries and/or may also be powered by the power supply unit 16. No specific limitation will be given in the present disclosure.

Embodiments of the present disclosure provide a device for monitoring fatigue driving. The device for monitoring fatigue driving comprises a processor and a monitoring unit, an alarm unit and an inflating unit which are respectively

connected with the processor. The processor is configured to acquire a monitoring result, send an alarm instruction to the alarm unit according to the monitoring result, and send an inflating instruction to the inflating unit if acquiring the monitoring result again after sending the alarm instruction. The monitoring result is used for indicating that the driver is in the fatigue driving state; the alarm instruction is used for instructing the alarm unit to give out an alarm; and the inflating instruction is used for instructing the inflating unit to perform an inflation operation. The monitoring unit is configured to monitor the driving state of the driver in real time, and send data indicating the driving state of the driver to the processor. The alarm unit is configured to receive the alarm instruction sent by the processor, and give out an alarm according to the alarm instruction. The inflating unit is configured to receive the inflating instruction sent by the processor, and perform an inflation operation according to the inflating instruction.

Based on the above technical solutions, the device for monitoring fatigue driving provided by the present disclosure may monitor the driving state of the driver in real time in the monitoring process, and give out an alarm when the driver is in the fatigue driving state, so as to prompt the driver that he/she is in the fatigue driving state. The device for monitoring fatigue driving may perform an inflation operation if it is detected that the driver continues to be in the fatigue driving state after giving out the alarm. As the inflating operation can result in an extrusion pressing with a certain intensity on the driver's body, it is helpful for the driver to restore from the fatigue driving state to the clearheaded driving state, so that the probability that the driver restores from the fatigue driving state to the clearheaded driving state can be increased, and hence the probability of safety problems emerging when the driver is in the fatigue driving state can be reduced.

For instance, as shown in FIG. 8, embodiments of the present disclosure provide a method for monitoring fatigue driving. The method may be applied to the device for monitoring fatigue driving as shown in any one of FIGS. 1-7. The detailed description on the device for monitoring fatigue driving may be with reference to with the relevant description as shown in FIGS. 1-7. No further description will be given here. The method may comprise:

S101: monitoring, by the device for monitoring fatigue driving, a driving state of a driver in real time.

S102: providing, by the device for monitoring fatigue driving, an alarm if the driving state of the driver is determined to be a fatigue driving state. For instance, the device for monitoring fatigue driving may give out a voice, light or vibrating alarm signal.

S103: performing, by the device for monitoring fatigue driving, an inflation operation if the driving state of the driver is still determined to be the fatigue driving state after providing the alarm. The inflating operation helps the driver to restore to a clearheaded driving state.

In embodiments of the present disclosure, the device for monitoring fatigue driving may monitor the driving state of the driver in real time, give out an alarm to prompt the driver that he/she is in the fatigue driving state when the driving state of the driver is the fatigue driving state, and perform an inflation operation if it is continuously detected that the driver is still in the fatigue driving state after giving out the alarm. As the inflating operation can result in extrusion pressing with certain intensity on the driver's body, it is helpful for the driver to restore from the fatigue driving state to the clearheaded driving state, so that the probability that the driver restores from the fatigue driving state to the

clearheaded driving state can be improved, and hence the probability of safety problems emerging when the driver is in the fatigue driving state can be reduced.

For instance, a specific form and structure of the device for monitoring fatigue driving and an implementation principle of the inflating operation of the device for monitoring fatigue driving may all be provided with reference to relevant description in the above embodiment. No further description will be given here.

For instance, as shown in FIG. 9, in the method for monitoring fatigue driving provided by embodiments of the present disclosure, the step **S103** may include:

S103a: inflating, by the device for monitoring fatigue driving, a cuff of the device if the driving state of the driver is still determined to be in the fatigue driving state after providing the alarm. The detailed description on the cuff may be provided with reference to relevant description on the cuff in the above embodiments. No further description will be given here.

For instance, as shown in FIG. 10, the method for monitoring fatigue driving provided by embodiments of the present disclosure may further comprise:

S104: detecting, by the device for monitoring fatigue driving, a value of a pressure intensity caused by the cuff when the cuff is inflated.

S105: deflating, by the device for monitoring fatigue driving, the cuff if the value of the pressure intensity is greater than or equal to a default threshold.

Moreover, in the process of inflating the cuff by the device for monitoring fatigue driving, in order to prevent the brain of the driver from being overly oppressed by an overlarge pressure of the cuff on the brain of the driver, the device for monitoring fatigue driving may detect a value of the pressure intensity of the cuff in real time, and deflate the cuff when the value of the pressure intensity is greater than or equal to the default threshold, so that the pressure of the cuff applied on the brain of the driver can be reduced, and hence the brain of the driver cannot be overly oppressed.

The default threshold may be set according to actual design demands of the device for monitoring fatigue driving. No specific limitation will be given in the present disclosure.

In embodiments of the present disclosure, the implementation principle of the deflating operation by the device for monitoring fatigue driving may be provided with reference to relevant description in the above embodiments. No further description will be given here.

It should be noted that: in embodiments of the present disclosure, the steps **S104-S105** may be simultaneously executed when the step **S103** is executed, so as to avoid the problem that the brain of the driver is overly oppressed due to overlarge pressure of the cuff on the brain of the driver when the device for monitoring fatigue driving continuously inflates the cuff.

For instance, with reference to FIG. 8, as shown in FIG. 11, in the method for monitoring fatigue driving provided by embodiments of the present disclosure, the steps **S101** and **S102** may include:

S101a: monitoring, by the device for monitoring fatigue driving, eyes of the driver and the brain of the driver in real time.

S102a: providing, by the device for monitoring fatigue driving, an alarm if both the eyes of the driver and the brain of the driver are determined to be in the fatigue state.

The method for monitoring fatigue driving provided by embodiments of the present disclosure simultaneously monitors whether the eyes of the driver are in the fatigue state and whether the brain of the driver is in the fatigue

state, can determine whether the driver is in the fatigue driving state according to the two monitoring results, and hence can improve the monitoring accuracy of the device for monitoring fatigue driving.

For instance, as shown in FIG. 12, in the method for monitoring fatigue driving provided by embodiments of the present disclosure, the step S101a may include:

S101aa: extracting, by the device for monitoring fatigue driving, eye features of the driver in real time, and acquiring EEG signals of the driver.

S101ab: determining, by the device for monitoring fatigue driving, whether the eyes of the driver are in the fatigue state according to the eye features of the driver.

S101ac: determining, by the device for monitoring fatigue driving, whether the brain of the driver is in the fatigue state according to the EEG signals of the driver.

For instance, the method of determining whether the driver is in the fatigue driving state by monitoring the eye features of the driver and the EEG signals of the driver, which is performed by the device for monitoring fatigue driving, and specific hardware to implement the method may be provided with reference to relevant description in the above embodiments. No further description will be given here.

Embodiments of the present disclosure provide a method for monitoring fatigue driving, in which the device for monitoring fatigue driving is adopted to monitor the driving state of the driver in real time. If the driving state of the driver is the fatigue driving state, the device for monitoring fatigue driving gives out an alarm; and if the driving state of the driver is still in the fatigue driving state after giving out the alarm, the device for monitoring fatigue driving performs an inflation operation.

Based on the above technical solutions, the device for monitoring fatigue driving provided by the present disclosure may monitor the driving state of the driver in real time in the monitoring process, and give out an alarm when the driver is in the fatigue driving state, so as to prompt the driver that he/she is in the fatigue driving state, and perform an inflation operation if it is continuously detected that the driver is still in the fatigue driving state after giving out the alarm. As the inflating operation can result in extrusion pressing with certain intensity on the driver's body, it is helpful for the driver to restore from the fatigue driving state to the clearheaded driving state, so that the probability that the driver restores from the fatigue driving state to the clearheaded driving state can be improved, and hence the probability of occurrence of safety problems when the driver is in the fatigue driving state can be reduced.

The processor or microprocessor included in the device for monitoring fatigue driving in embodiments of the disclosure may include various computing architectures such as a complex instruction set computer (CISC) architecture, a reduced instruction set computer (RISC) architecture or an architecture for implementing a combination of multiple instruction sets. The memory may store instructions and/or data executed by the processor. The instructions and/or data may include codes which are configured to achieve some functions or all the functions of one or more devices in the embodiments of the present disclosure. For instance, the memory includes a dynamic random access memory (DRAM), a static random access memory (SRAM), a flash memory, an optical memory or other memories well known to those skilled in the art.

It should be clearly understood by those skilled in the art that the foregoing is only illustrative for convenient and

simple description, and other similar embodiments may also be provided in actual application.

It should be understood that the functional modules disclosed in several embodiments of the application may be implemented by other means. For instance, the structural modules described above are only illustrative. Moreover, the displayed or discussed connection may be connection via some pins, and may be electrical connection.

The units described as discrete components may be or may not be physically separate, and components displayed as units may be or may not be physical units, may be disposed at one place or may also be distributed on a plurality of units. Partial or all the units may be selected according to actual demands to achieve the objectives of the proposals of the embodiments.

In addition, the functional units in the embodiments of the present disclosure may be integrated into a processing unit, or various units may be independently physically provided, or two or more than two units may be integrated into one unit. The integrated units may be implemented by hardware and may also be implemented by software functional units.

In the present disclosure, terms such as "first", "second" and the like used in the present disclosure do not indicate any sequence, quantity or significance but only for distinguishing different constituent parts. Also, the terms such as "a," "an," or "the" etc., are not intended to limit the amount, but indicate the existence of at least one. The terms "comprises," "comprising," "includes," "including," etc., are intended to specify that the elements or the objects stated before these terms encompass the elements or the objects and equivalents thereof listed after these terms, but do not preclude the other elements or objects.

What are described above is related to the illustrative embodiments of the disclosure only and not limitative to the scope of the disclosure; any changes or replacements easily for those technical personnel who are familiar with this technology in the field to envisage in the scopes of the disclosure, should be in the scope of protection of the present disclosure. Therefore, the scopes of the disclosure are defined by the accompanying claims.

The present application claims the priority of the Chinese Patent Application No. 201510170673.6 filed on Apr. 10, 2015, which is incorporated herein by reference in its entirety as part of the disclosure of the present application.

What is claimed is:

1. A device for monitoring fatigue driving, comprising a processor, and a monitoring unit, an alarm unit and an inflating unit which are respectively connected with the processor, wherein:

the processor is configured to acquire a monitoring result, send an alarm instruction to the alarm unit according to the monitoring result, and send an inflating instruction to the inflating unit when acquiring the monitoring result again after sending the alarm instruction, wherein the monitoring result is used for indicating whether a driver is in a fatigue driving state, the alarm instruction is used for instructing the alarm unit to give out an alarm, and the inflating instruction is used for instructing the inflating unit to perform an inflation operation; the monitoring unit is configured to monitor the driving state of the driver in real time, and send data indicating the driving state of the driver to the processor;

the alarm unit is configured to receive the alarm instruction sent by the processor, and give out the alarm according to the alarm instruction; and

the inflating unit is configured to receive the inflating instruction sent by the processor, and perform the inflation operation according to the inflating instruction,

wherein the inflating unit includes a microprocessor connected with the processor, a driving module connected with the microprocessor, and a cuff connected with the driving module, wherein:

the microprocessor is configured to receive the inflating instruction sent by the processor, and send an inflating signal to the driving module according to the inflating instruction;

the driving module is configured to receive the inflating signal sent by the microprocessor, and inflate the cuff according to the inflating signal;

wherein the cuff is wound around the driver's head to impose pressure on the driver's head when it is inflated so as to increase the amount of blood supply on the driver's head.

2. The device for monitoring fatigue driving according to claim 1, wherein the inflating unit further includes a pressure sensor connected with both the microprocessor and the cuff, wherein:

the pressure sensor is configured to detect a value of a pressure intensity of the cuff when the driving module inflates the cuff, and send the value of the pressure intensity to the microprocessor;

the microprocessor is also configured to receive the value of the pressure intensity sent by the pressure sensor, and send a deflating signal to the driving module when the value of the pressure intensity is greater than or equal to a default threshold; and

the driving module is also configured to receive the deflating signal sent by the microprocessor, and deflate the cuff according to the deflating signal.

3. The device for monitoring fatigue driving according to claim 2, wherein:

the driving module is a miniature inflation motor; or

the driving module includes a miniature pressure pump and a miniature exhaust valve.

4. The device for monitoring fatigue driving according to claim 1, wherein:

the driving module is a miniature inflation motor; or

the driving module includes a miniature pressure pump and a miniature exhaust valve.

5. The device for monitoring fatigue driving according to claim 1, wherein the monitoring unit includes at least one of a face monitoring module or a brain monitoring module;

the face monitoring module is configured to monitor eyes of the driver and send data indicating an eye state of the driver to the processor; and

the brain monitoring module is configured to monitor a brain of the driver and send data indicating a brain state of the driver to the processor.

6. The device for monitoring fatigue driving according to claim 5, wherein:

the face monitoring module is a miniature camera; and

the brain monitoring module is an electroencephalogram (EEG) sensor.

7. The device for monitoring fatigue driving according to claim 1, wherein the device for monitoring fatigue driving further comprises a power supply unit connected with the processor, the monitoring unit, the alarm unit and the inflating unit; and

the power supply unit is configured to supply power for the processor, the monitoring unit, the alarm unit and the inflating unit.

8. The device for monitoring fatigue driving according to claim 7, wherein:

the power supply unit is charged by a wireless charging approach.

9. The device for monitoring fatigue driving according to claim 1, wherein the device for monitoring fatigue driving further comprises a switching unit connected with the processor; and

the switching unit is configured to control the device for monitoring fatigue driving to switch on or off.

10. The device for monitoring fatigue driving according to claim 9, wherein:

the switching unit is a mechanical switch or an acceleration sensor.

11. The device for monitoring fatigue driving according to claim 1, wherein:

the alarm unit includes at least one of a voice alarm module or a vibrating motor alarm module.

12. The device for monitoring fatigue driving according to claim 1, further comprising a switching unit connected with the processor,

wherein the switching unit is configured to control the device for monitoring fatigue driving to switch on or off.

13. A method for monitoring fatigue driving, applied in a device for monitoring fatigue driving according to claim 1, comprising:

monitoring, by the device for monitoring fatigue driving, a driving state of a driver in real time;

providing, by the device for monitoring fatigue driving, an alarm if the driving state of the driver is determined to be a fatigue driving state; and

performing, by the device for monitoring fatigue driving, an inflation operation if the driving state of the driver is still determined to be the fatigue driving state after providing the alarm.

14. The method according to claim 13, wherein performing, by the device for monitoring fatigue driving, the inflation operation if the driving state of the driver is still determined to be the fatigue driving state after providing the alarm includes:

inflating a cuff of the device for monitoring fatigue driving if the driving state of the driver is still determined to be the fatigue driving state after providing the alarm.

15. The method according to claim 14, further comprising:

detecting, by the device for monitoring fatigue driving, a value of a pressure intensity of the cuff when the cuff is inflated; and

deflating the cuff if the value of the pressure intensity is greater than or equal to a default threshold.

16. The method according to claim 13, wherein:

monitoring, by the device for monitoring fatigue driving, the driving state of a driver in real time includes:

monitoring, by the device for monitoring fatigue driving, eyes of the driver and a brain of the driver in real time; and

performing, by the device for monitoring fatigue driving, the inflation operation if the driving state of the driver is still determined to be the fatigue driving state after providing the alarm includes:

providing, by the device for monitoring fatigue driving, the alarm if both the eyes of the driver and the brain of the driver are determined to be in a fatigue state.

17. The method according to claim 16, wherein monitoring, by the device for monitoring fatigue driving, the eyes of the driver and the brain of the driver in real time includes: extracting, by the device for monitoring fatigue driving, eye features of the driver in real time, and acquiring an EEG signal of the driver; determining, by the device for monitoring fatigue driving, whether the eyes of the driver are in the fatigue state according to the eye features; and determining, by the device for monitoring fatigue driving, whether the brain of the driver is in the fatigue state according to the EEG signal.

* * * * *

专利名称(译)	用于监测疲劳驾驶的方法和装置		
公开(公告)号	US10390749	公开(公告)日	2019-08-27
申请号	US15/510854	申请日	2016-02-23
[标]申请(专利权)人(译)	京东方科技集团股份有限公司		
申请(专利权)人(译)	京东方科技集团股份有限公司.		
当前申请(专利权)人(译)	京东方科技集团股份有限公司.		
[标]发明人	ZHANG JINGYU SUN WEI		
发明人	ZHANG, JINGYU SUN, WEI		
IPC分类号	A61B5/18 G08B21/06 A61B5/11 A61B5/00 A61M21/00 A61B3/10 A61B5/022 A61B5/0476 B60K28/06 A61B5/048 A61B5/01 B60W40/08		
审查员(译)	栾, SCOTT		
优先权	201510170673.6 2015-04-10 CN		
其他公开文献	US20170281068A1		
外部链接	Espacenet		

摘要(译)

一种用于监测疲劳驾驶的方法和装置。该装置包括处理器，监控单元，报警单元和连接到处理器的充气单元。处理器用于获取监控结果，根据监控结果向报警单元发送报警指令，并在发送报警指令后再次获取监控结果时，向充气单元发送充气指令。监控单元用于实时监控驾驶员的驾驶状态，并发送指示驾驶员驾驶状态的数据;报警单元(12)用于接收报警指令，并根据报警指令提供报警;充气装置用于接收充气指令，并根据充气指令充气。

