



(19) **United States**

(12) **Patent Application Publication**

Felix et al.

(10) **Pub. No.: US 2019/0246933 A1**

(43) **Pub. Date: Aug. 15, 2019**

(54) **EXTENDED WEAR
ELECTROCARDIOGRAPHY MONITOR
WITH WIRE ELECTRODE ASSEMBLIES**

A61B 5/044 (2006.01)

A61B 5/0428 (2006.01)

A61B 5/04 (2006.01)

(71) Applicant: **Bardy Diagnostics, Inc.**, Seattle, WA (US)

(52) **U.S. Cl.**
CPC *A61B 5/04087* (2013.01); *A61B 5/0006* (2013.01); *A61B 5/04085* (2013.01); *A61B 5/044* (2013.01); *A61B 5/6823* (2013.01); *A61B 5/04325* (2013.01); *A61B 5/04017* (2013.01); *A61B 5/6832* (2013.01); *A61B 2560/0412* (2013.01); *A61B 2560/0456* (2013.01); *A61B 5/0428* (2013.01)

(72) Inventors: **Jason Felix**, Vashon Island, WA (US); **Jon Mikalson Bishay**, Lexington, KY (US); **Gust H. Bardy**, Carnation, WA (US)

(21) Appl. No.: **16/389,798**

(57) **ABSTRACT**

(22) Filed: **Apr. 19, 2019**

Related U.S. Application Data

(63) Continuation of application No. 15/661,362, filed on Jul. 27, 2017, now Pat. No. 10,264,992, which is a continuation of application No. 14/488,256, filed on Sep. 16, 2014, now Pat. No. 9,717,433, which is a continuation-in-part of application No. 14/080,725, filed on Nov. 14, 2013, now Pat. No. 9,730,593.

Physiological monitoring can be provided through a light-weight wearable monitor that includes two components, a flexible extended wear electrode patch with sewn electrodes and a reusable monitor recorder that removably snaps into a receptacle on the electrode patch. The monitor sits centrally on the patient's chest along the sternum oriented top-to-bottom. The placement of the wearable monitor in a location at the sternal midline, with its unique narrow "hourglass"-like shape, significantly improves the ability of the wearable monitor to cutaneously sense cardiac electrical potential signals, particularly the P-wave and the QRS interval signals indicating ventricular activity in the ECG waveforms. In particular, the ECG electrodes on the electrode patch are tailored to be positioned axially along the midline of the sternum for capturing action potential propagation in an orientation that corresponds to the aVF lead used in a conventional 12-lead ECG that is used to sense positive or upright P-waves.

(60) Provisional application No. 61/882,403, filed on Sep. 25, 2013.

Publication Classification

(51) **Int. Cl.**
A61B 5/0408 (2006.01)
A61B 5/00 (2006.01)

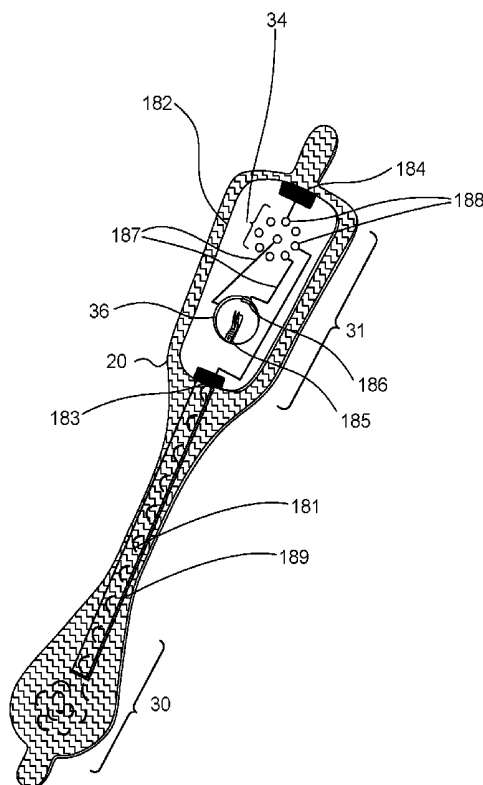

Fig. 1.

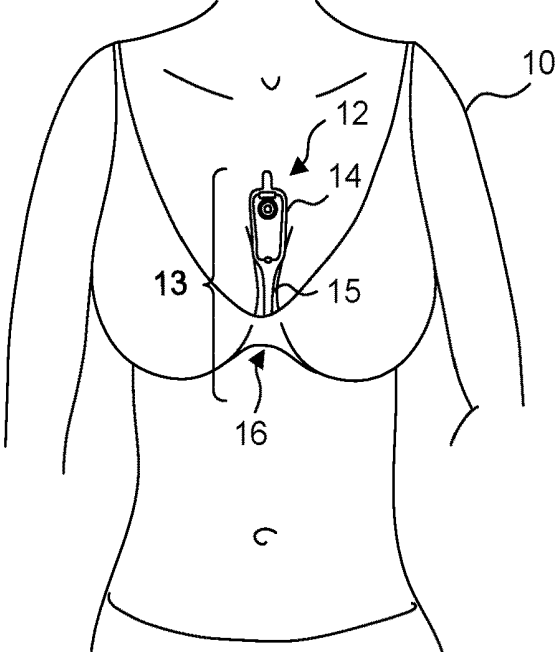

Fig. 2.

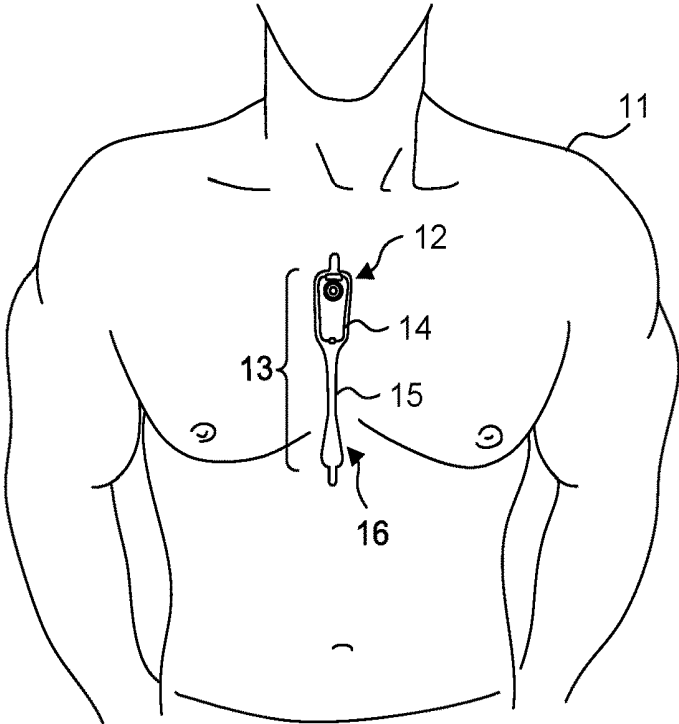

Fig. 3.

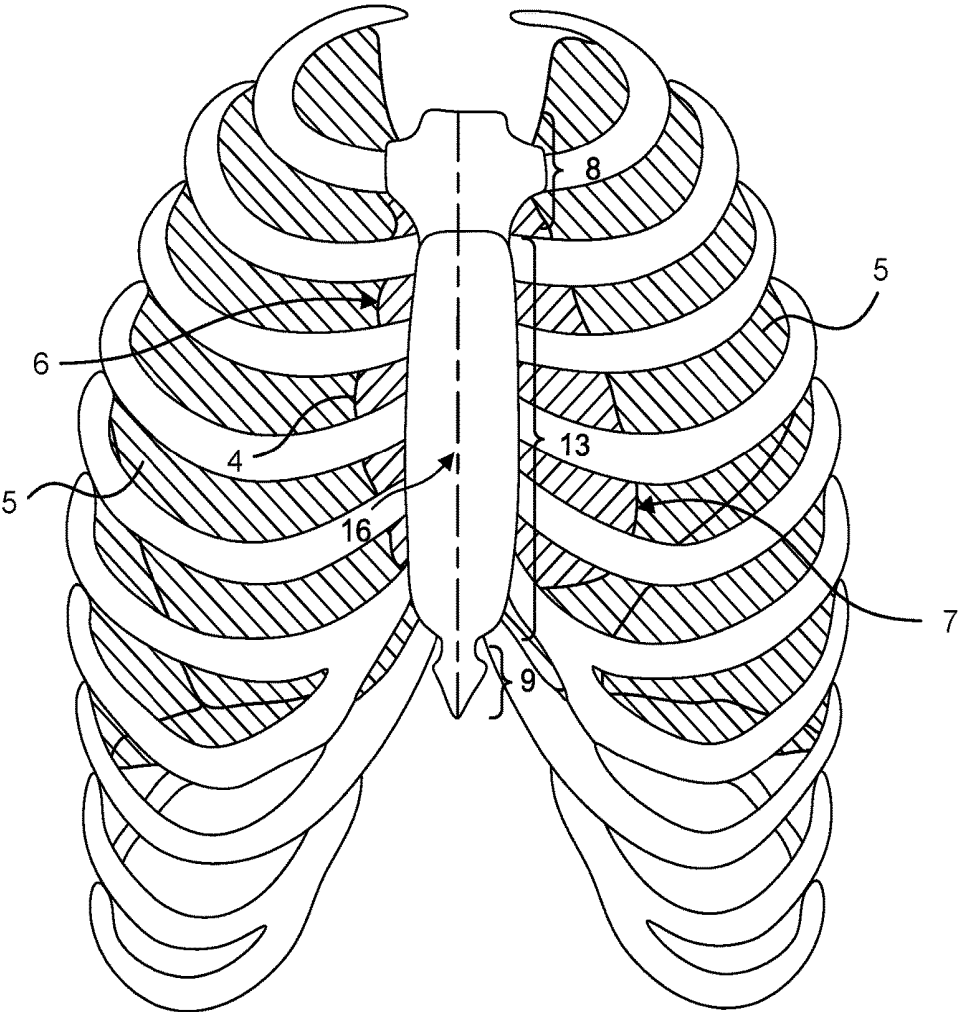

Fig. 4.

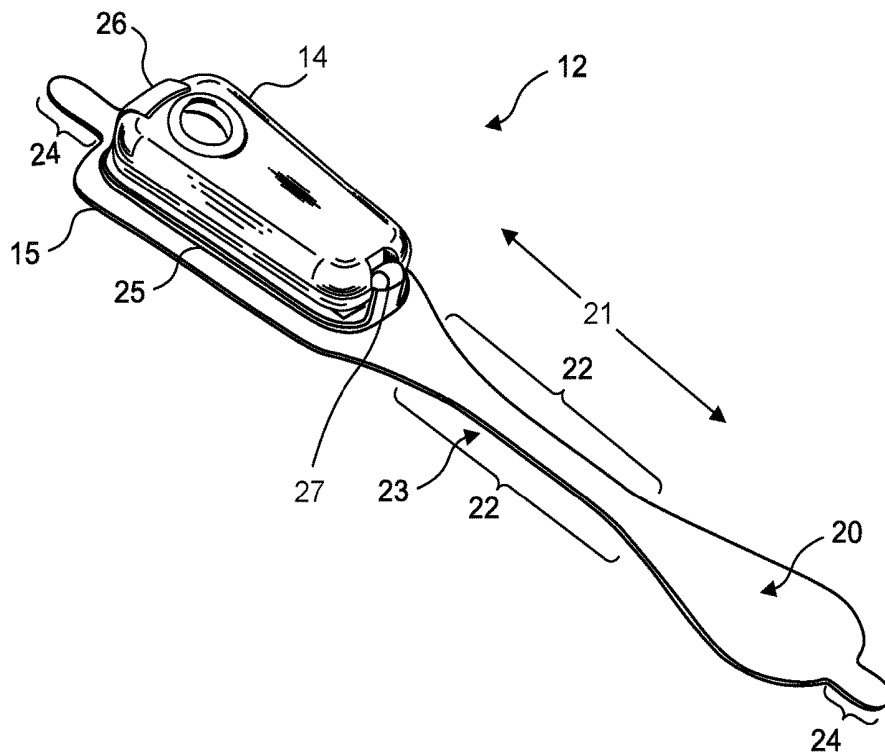

Fig. 5.

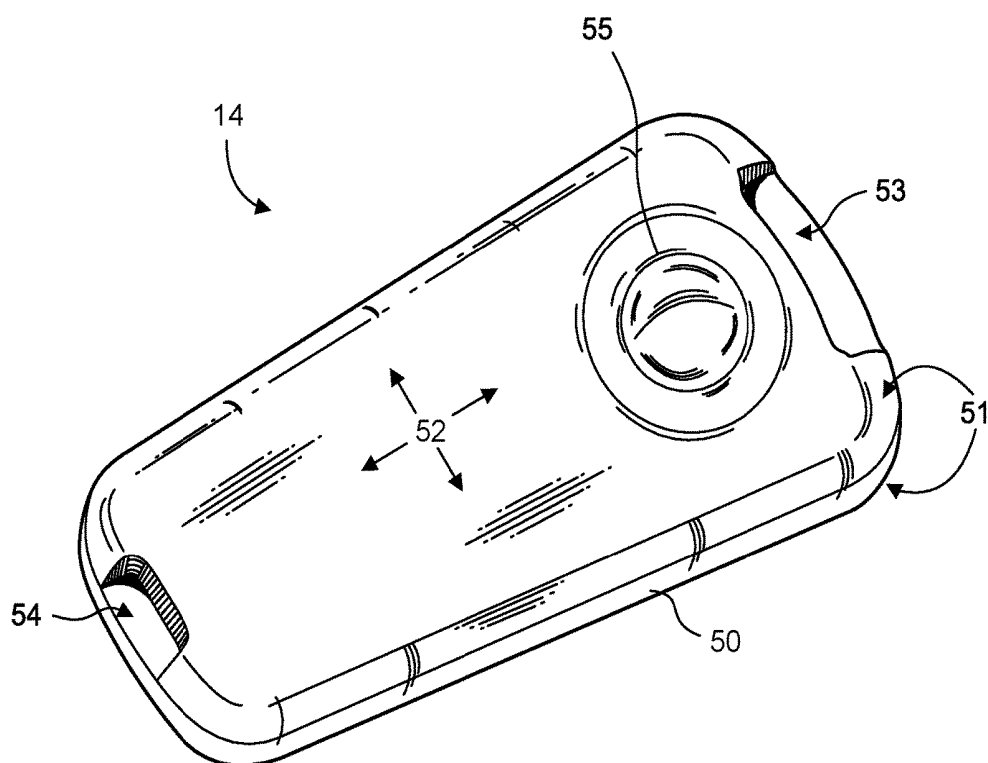

Fig. 6.

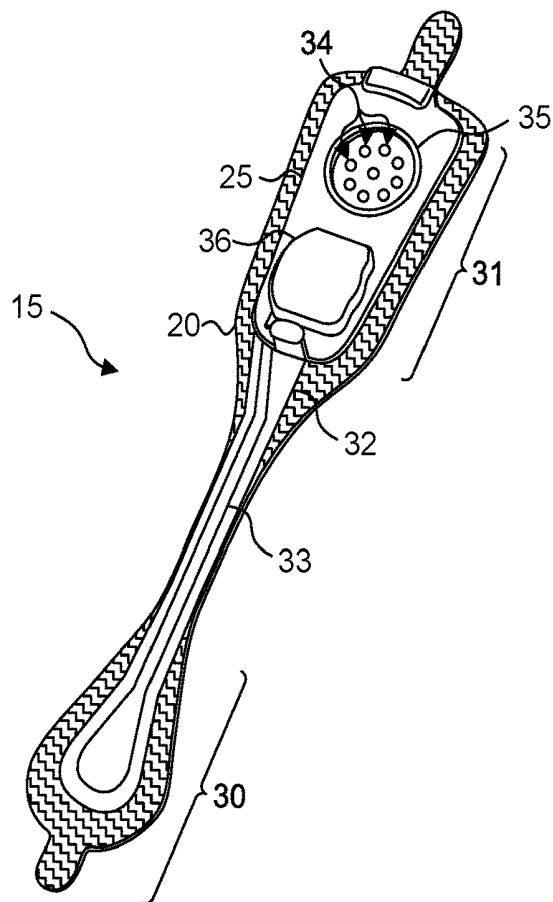

Fig. 7.

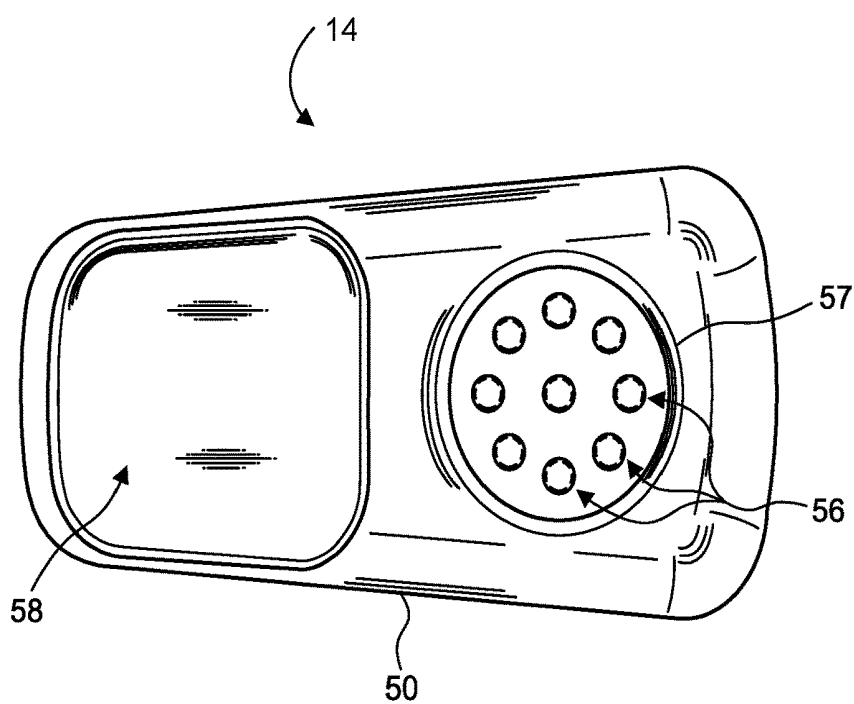

Fig. 8.

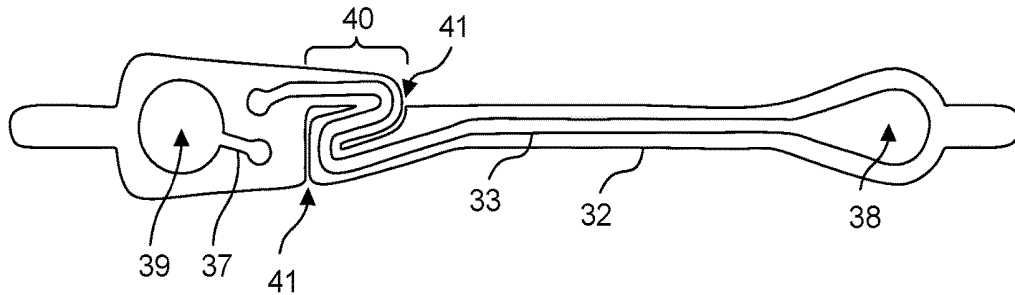

Fig. 9.

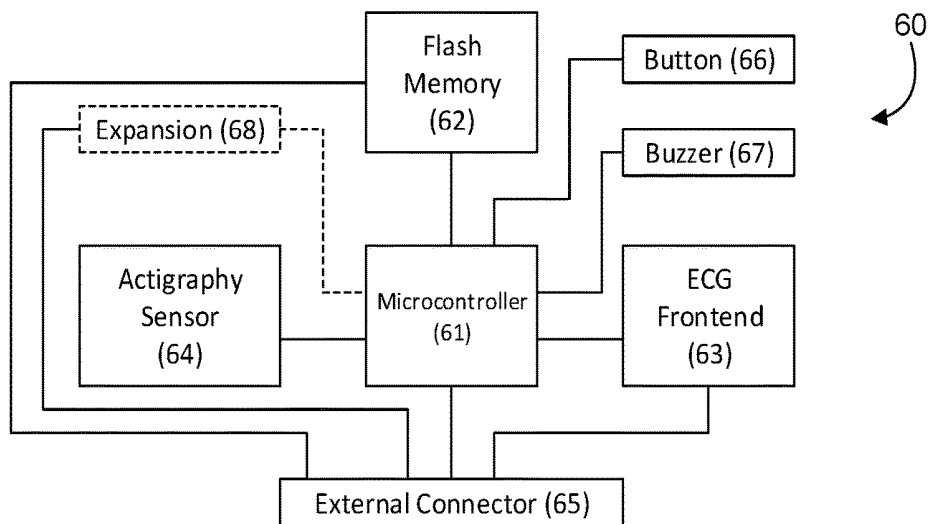

Fig. 10.

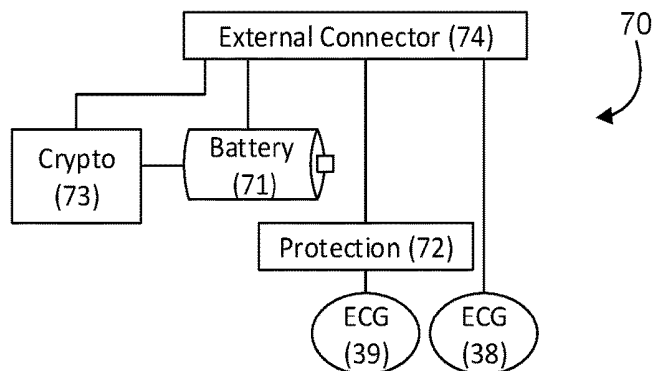

Fig. 11.

80

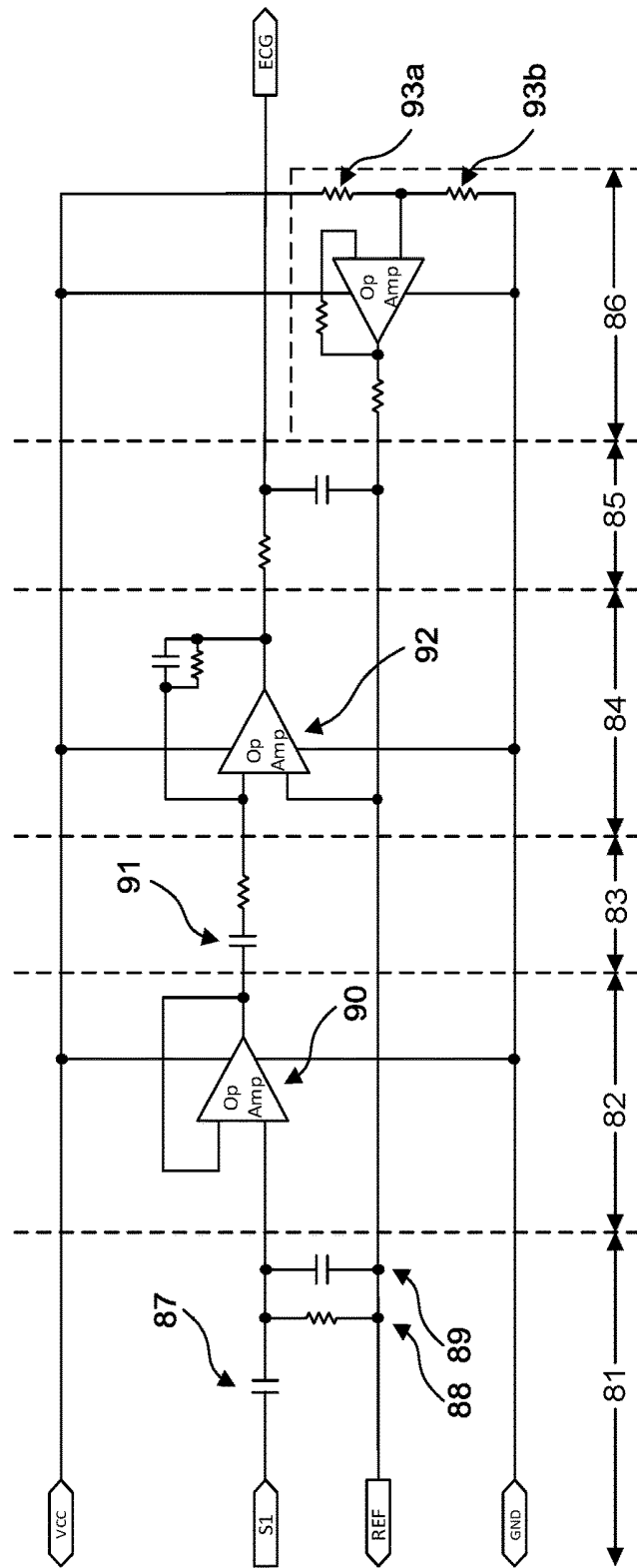

Fig. 12.

100

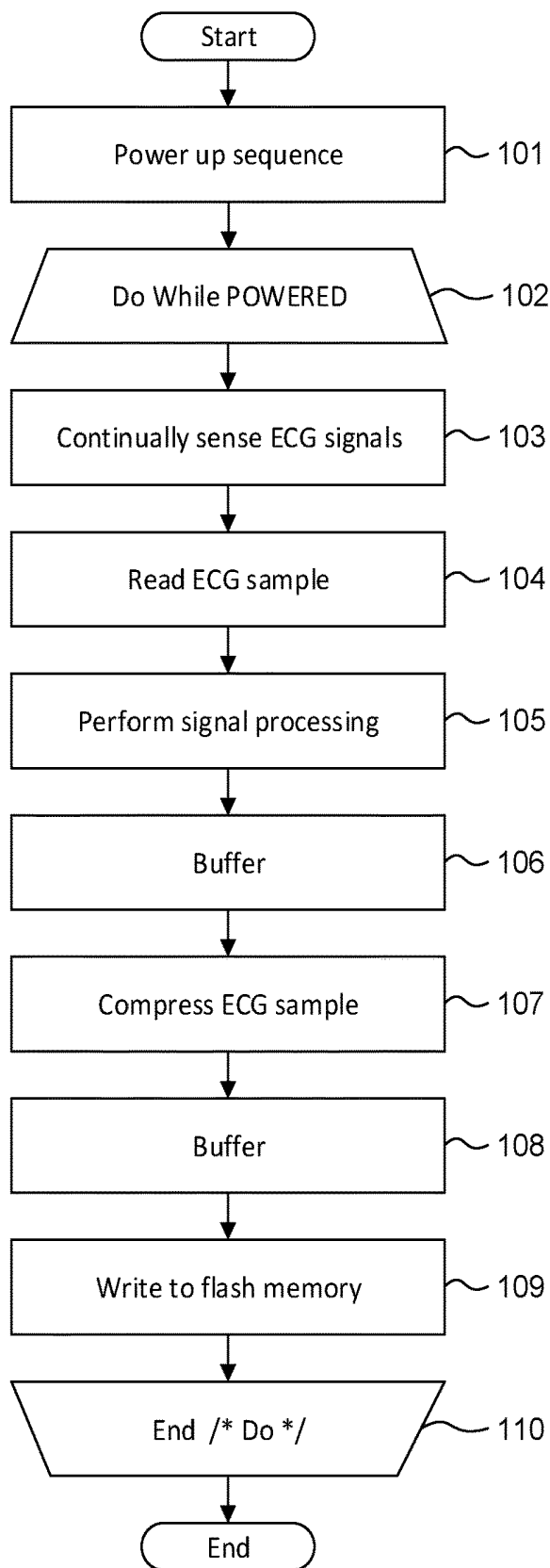

Fig. 13.

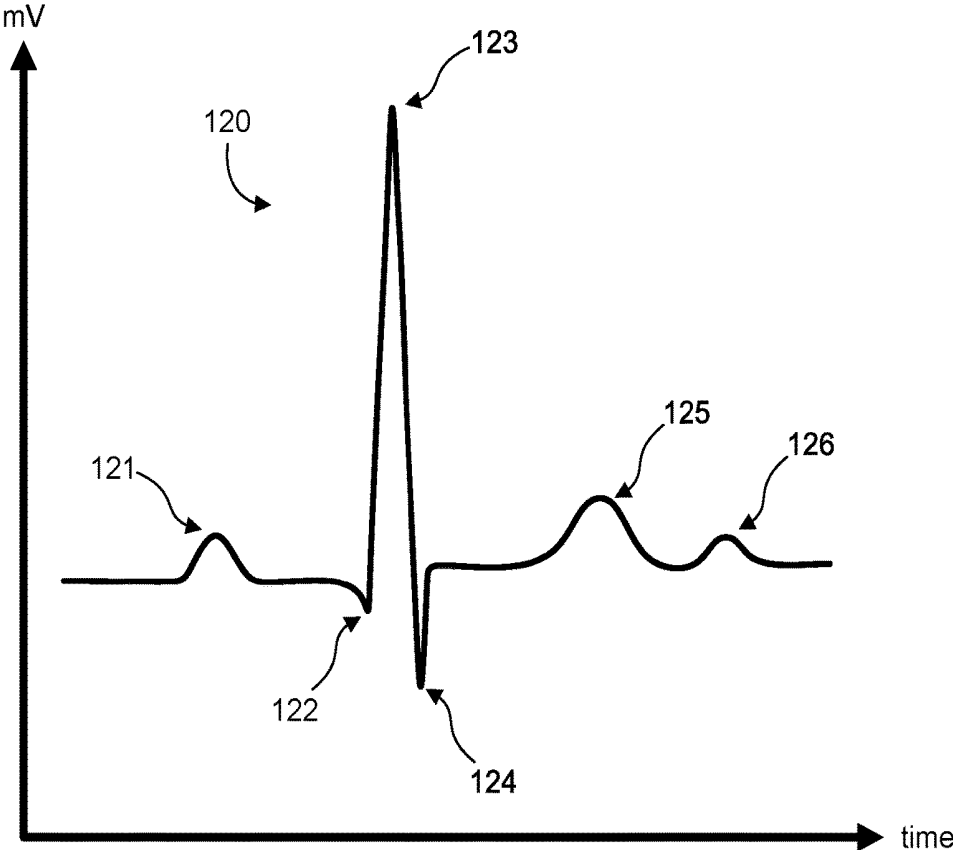

Fig. 14.

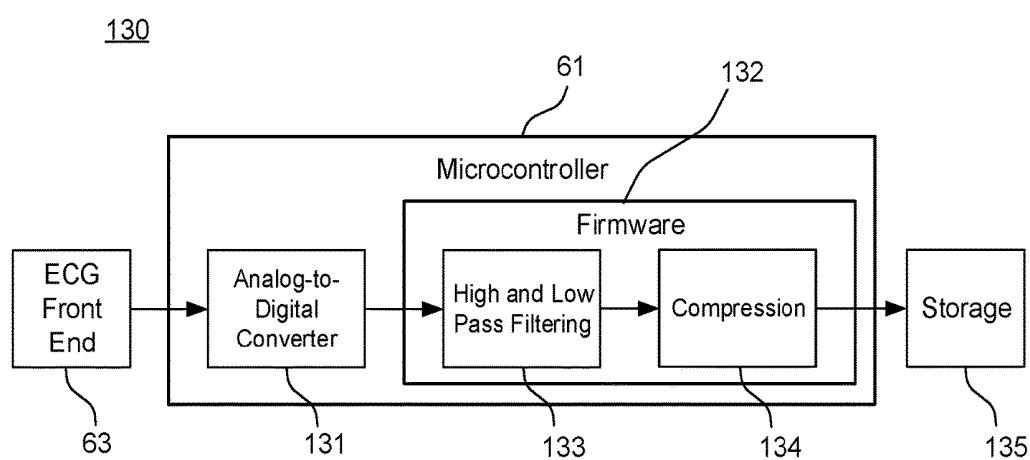

Fig. 15.

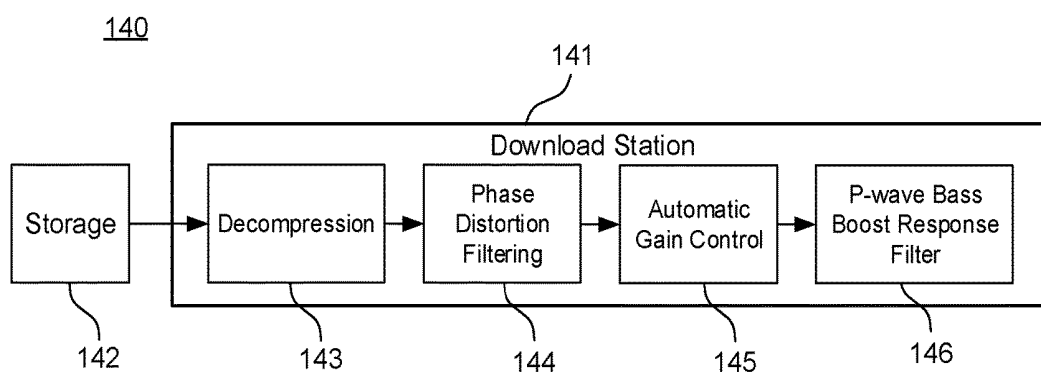

Fig. 16A.

150

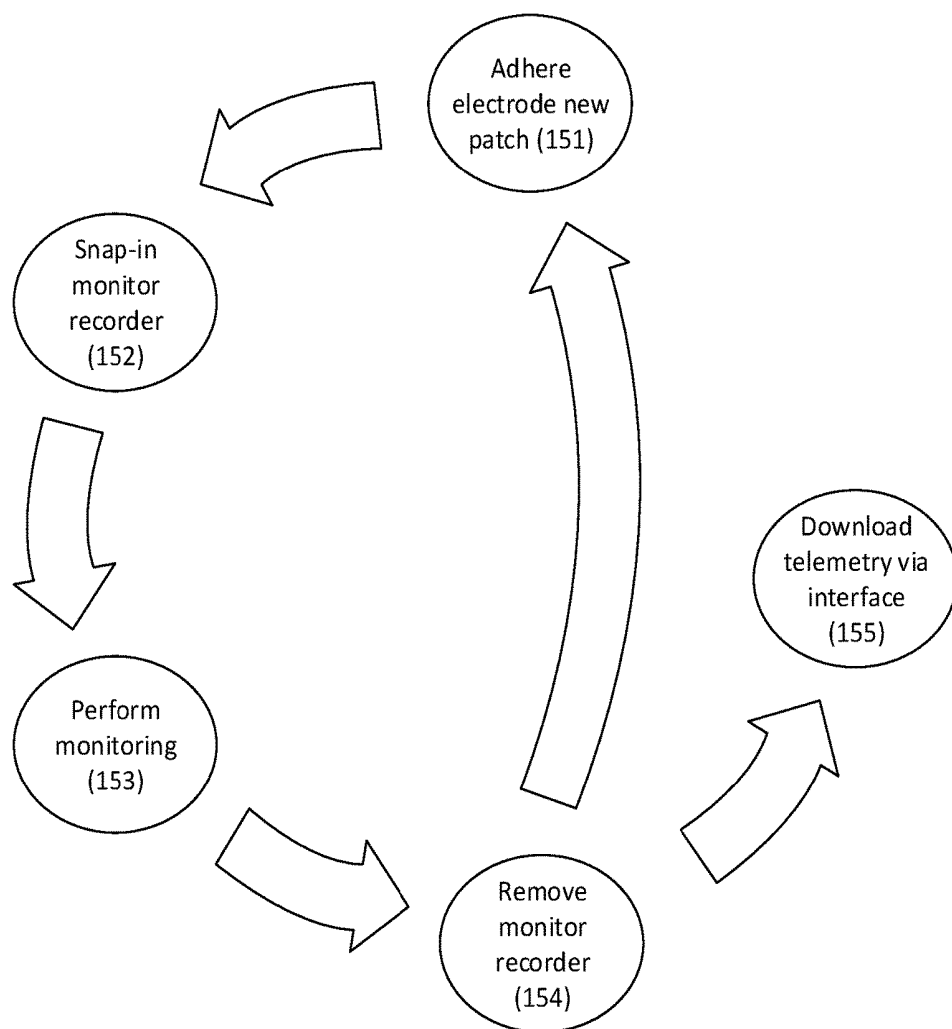

Fig. 16B.

160

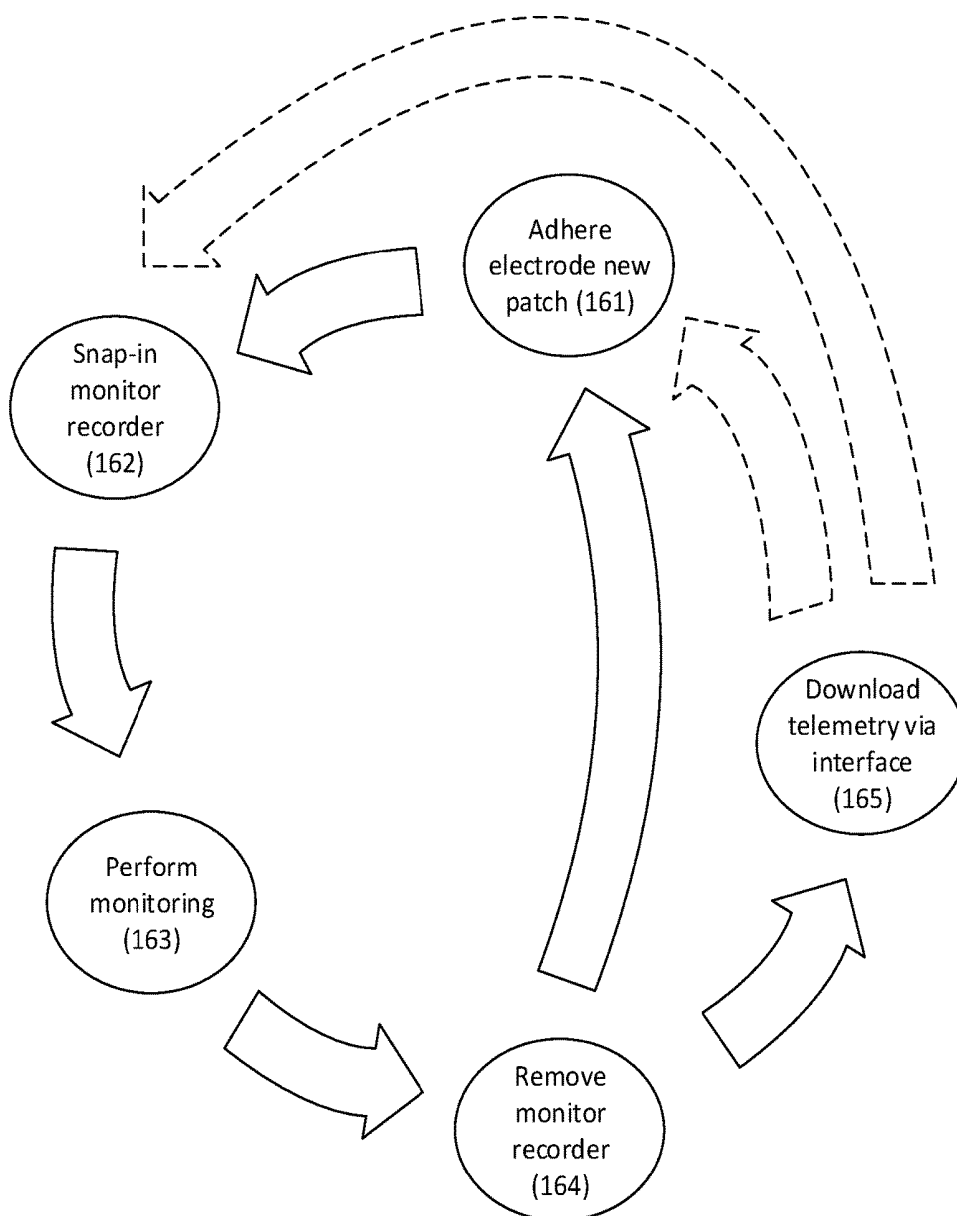

Fig. 16C.

170

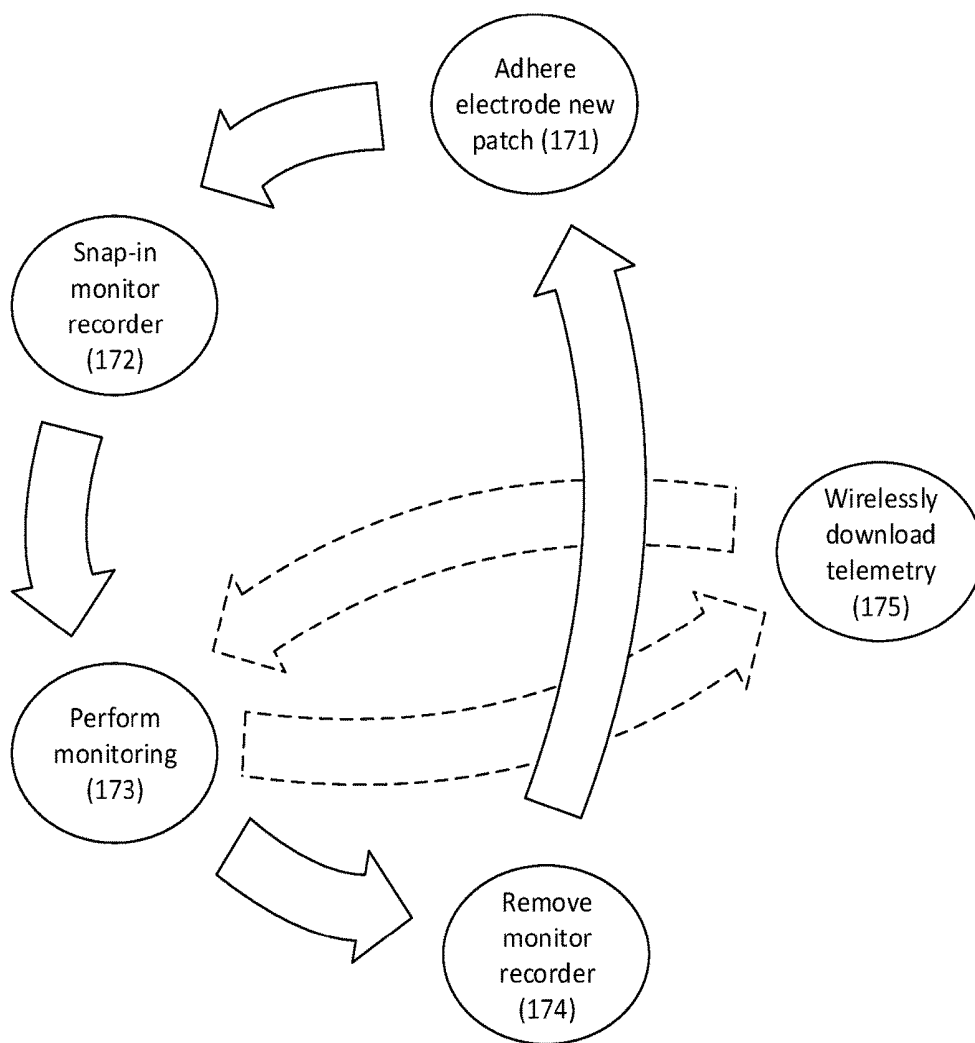

Fig. 17.

180

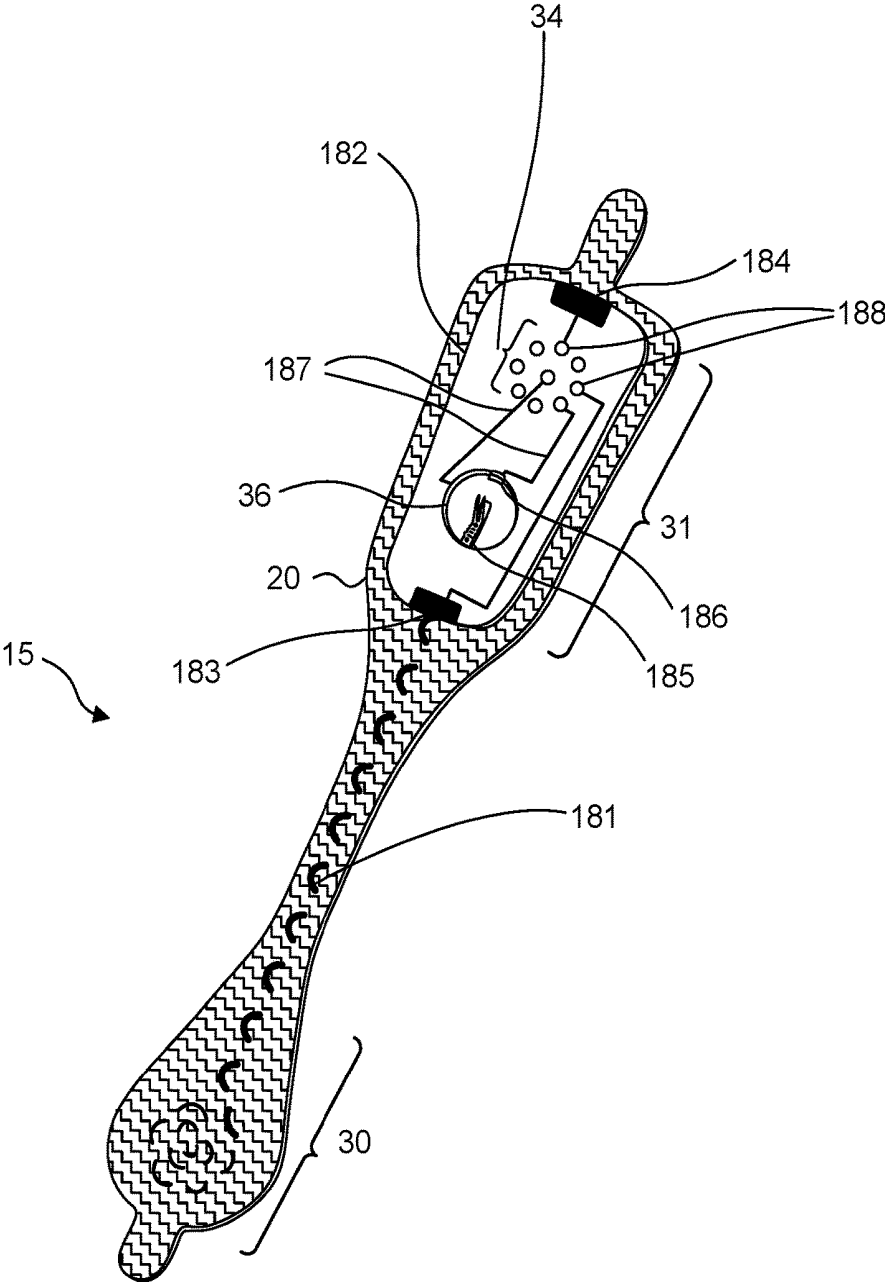

Fig. 18.

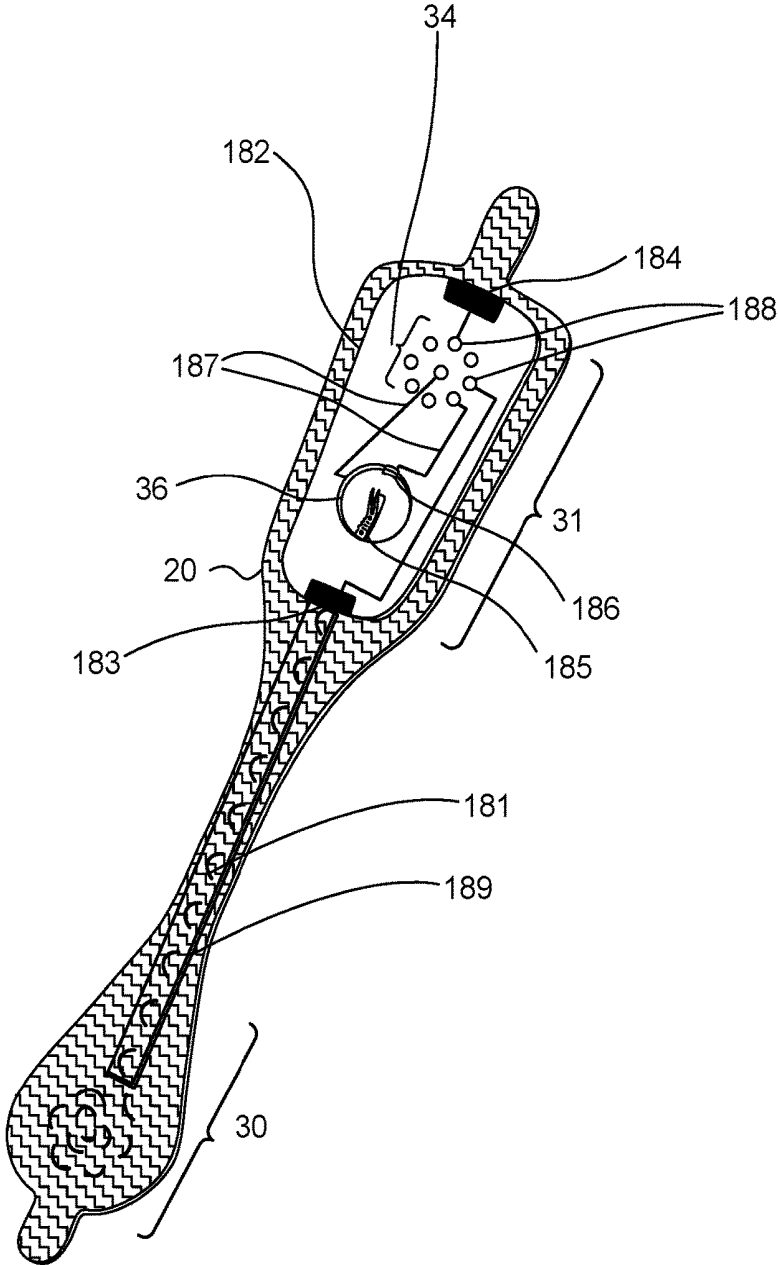

Fig. 19.

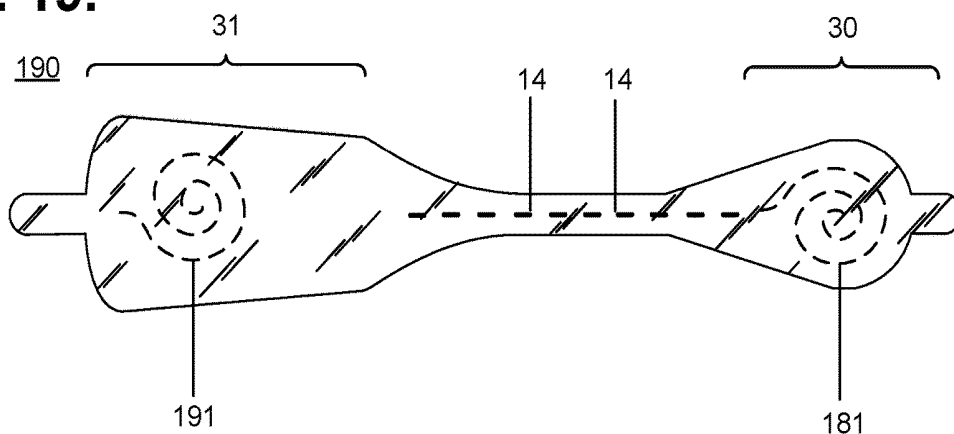

Fig. 20.

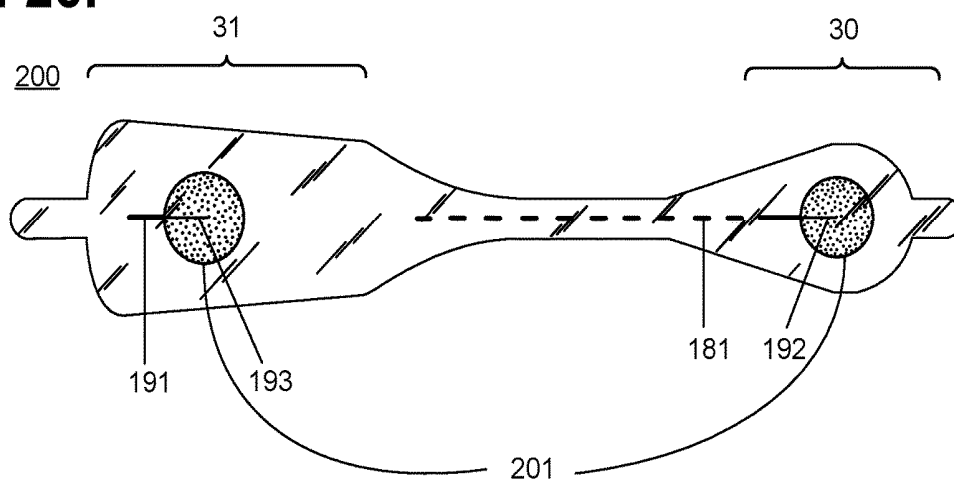
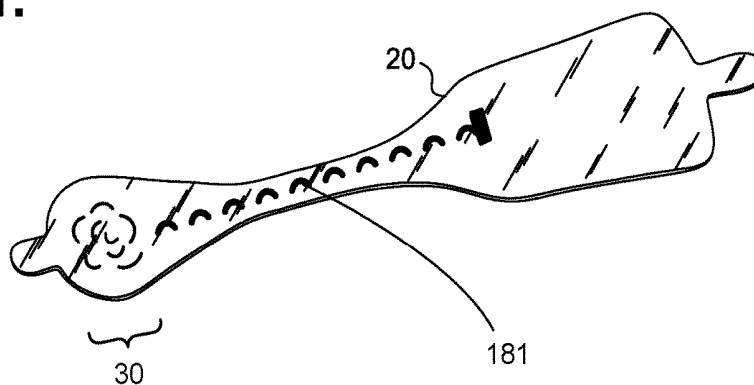

Fig. 21.



**EXTENDED WEAR
ELECTROCARDIOGRAPHY MONITOR
WITH WIRE ELECTRODE ASSEMBLIES**

CROSS-REFERENCE TO RELATED
APPLICATION

[0001] This non-provisional patent application is a continuation of U.S. patent application Ser. No. 15/661,362, filed Jul. 27, 2017, pending, which is a continuation of U.S. Pat. No. 9,717,433, issued Aug. 1, 2017, which is a continuation-in-part of U.S. Pat. No. 9,730,593, issued Aug. 15, 2017, and further claims priority under 35 U.S.C. § 119(e) to U.S. Provisional Patent application, Ser. No. 61/882,403, filed Sep. 25, 2013, the disclosures of which are incorporated by reference.

FIELD

[0002] This application relates in general to electrocardiographic monitoring and, in particular, to an extended electrocardiography monitor with wire electrode assemblies.

BACKGROUND

[0003] The first electrocardiogram (ECG) was invented by a Dutch physiologist, Willem Einthoven, in 1903, who used a string galvanometer to measure the electrical activity of the heart. Generations of physicians around the world have since used ECGs, in various forms, to diagnose heart problems and other potential medical concerns. Although the basic principles underlying Dr. Einthoven's original work, including his naming of various waveform deflections (Einthoven's triangle), are still applicable today, ECG machines have evolved from his original three-lead ECG, to ECGs with unipolar leads connected to a central reference terminal starting in 1934, to augmented unipolar leads beginning in 1942, and finally to the 12-lead ECG standardized by the American Heart Association in 1954 and still in use today. Further advances in portability and computerized interpretation have been made, yet the electronic design of the ECG recording apparatuses has remained fundamentally the same for much of the past 40 years.

[0004] Essentially, an ECG measures the electrical signals emitted by the heart as generated by the propagation of the action potentials that trigger depolarization of heart fibers. Physiologically, transmembrane ionic currents are generated within the heart during cardiac activation and recovery sequences. Cardiac depolarization originates high in the right atrium in the sinoatrial (SA) node before spreading leftward towards the left atrium and inferiorly towards the atrioventricular (AV) node. After a delay occasioned by the AV node, the depolarization impulse transits the Bundle of His and moves into the right and left bundle branches and Purkinje fibers to activate the right and left ventricles.

[0005] During each cardiac cycle, the ionic currents create an electrical field in and around the heart that can be detected by ECG electrodes placed on the skin. Cardiac electrical activity is then visually represented in an ECG trace by PQRSTU-waveforms. The P-wave represents atrial electrical activity, and the QRSTU components represent ventricular electrical activity. Specifically, a P-wave represents atrial depolarization, which causes atrial contraction.

[0006] P-wave analysis based on ECG monitoring is critical to accurate cardiac rhythm diagnosis and focuses on localizing the sites of origin and pathways of arrhythmic

conditions. P-wave analysis is also used in the diagnosis of other medical disorders, including imbalance of blood chemistry. Cardiac arrhythmias are defined by the morphology of P-waves and their relationship to QRS intervals. For instance, atrial fibrillation (AF), an abnormally rapid heart rhythm, can be confirmed by an absence of P-waves and an irregular ventricular rate. Similarly, sinoatrial block is characterized by a delay in the onset of P-waves, while junctional rhythm, an abnormal heart rhythm resulting from impulses coming from a locus of tissue in the area of the AV node, usually presents without P-waves or with inverted P-waves. Also, the amplitudes of P-waves are valuable for diagnosis. The presence of broad, notched P-waves can indicate left atrial enlargement. Conversely, the presence of tall, peaked P-waves can indicate right atrial enlargement. Finally, P-waves with increased amplitude can indicate hypokalemia, caused by low blood potassium, whereas P-waves with decreased amplitude can indicate hyperkalemia, caused by elevated blood potassium.

[0007] Cardiac rhythm disorders may present with lightheadedness, fainting, chest pain, hypoxia, syncope, palpitations, and congestive heart failure (CHF), yet rhythm disorders are often sporadic in occurrence and may not show up in-clinic during a conventional 12-second ECG. Continuous ECG monitoring with P-wave-centric action potential acquisition over an extended period is more apt to capture sporadic cardiac events. However, recording sufficient ECG and related physiological data over an extended period remains a significant challenge, despite an over 40-year history of ambulatory ECG monitoring efforts combined with no appreciable improvement in P-wave acquisition techniques since Dr. Einthoven's original pioneering work over a 110 years ago.

[0008] Electrocardiographic monitoring over an extended period provides a physician with the kinds of data essential to identifying the underlying cause of sporadic cardiac conditions, especially rhythm disorders, and other physiological events of potential concern. A 30-day observation period is considered the "gold standard" of monitoring, yet a 14-day observation period is currently pitched as being achievable by conventional ECG monitoring approaches. Realizing a 30-day observation period has proven unworkable with existing ECG monitoring systems, which are arduous to employ; cumbersome, uncomfortable and not user-friendly to the patient; and costly to manufacture and deploy. Still, if a patient's ECG could be recorded in an ambulatory setting over a prolonged time periods, particularly for more than 14 days, thereby allowing the patient to engage in activities of daily living, the chances of acquiring meaningful medical information and capturing an abnormal event while the patient is engaged in normal activities are greatly improved.

[0009] The location of the atria and their low amplitude, low frequency content electrical signals make P-waves difficult to sense, particularly through ambulatory ECG monitoring. The atria are located posteriorly within the chest, and their physical distance from the skin surface adversely affects current strength and signal fidelity. Cardiac electrical potentials measured dermally have an amplitude of only one-percent of the amplitude of transmembrane electrical potentials. The distance between the heart and ECG electrodes reduces the magnitude of electrical potentials in proportion to the square of change in distance, which compounds the problem of sensing low amplitude P-waves.

Moreover, the tissues and structures that lie between the activation regions within the heart and the body's surface alter the cardiac electrical field due to changes in the electrical resistivity of adjacent tissues. Thus, surface electrical potentials, when even capable of being accurately detected, are smoothed over in aspect and bear only a general spatial relationship to actual underlying cardiac events, thereby complicating diagnosis. Conventional 12-lead ECGs attempt to compensate for weak P-wave signals by monitoring the heart from multiple perspectives and angles, while conventional ambulatory ECGs primarily focus on monitoring higher amplitude ventricular activity that can be readily sensed. Both approaches are unsatisfactory with respect to the P-wave and the accurate, medically actionable diagnosis of the myriad cardiac rhythm disorders that exist.

[0010] Additionally, maintaining continual contact between ECG electrodes and the skin after a day or two of ambulatory ECG monitoring has been a problem. Time, dirt, moisture, and other environmental contaminants, as well as perspiration, skin oil, and dead skin cells from the patient's body, can get between an ECG electrode's non-conductive adhesive and the skin's surface. These factors adversely affect electrode adhesion and the quality of cardiac signal recordings. Furthermore, the physical movements of the patient and their clothing impart various compressional, tensile, bending, and torsional forces on the contact point of an ECG electrode, especially over long recording times, and an inflexibly fastened ECG electrode will be prone to becoming dislodged. Moreover, dislodgment may occur unbeknownst to the patient, making the ECG recordings worthless. Further, some patients may have skin that is susceptible to itching or irritation, and the wearing of ECG electrodes can aggravate such skin conditions. Thus, a patient may want or need to periodically remove or replace ECG electrodes during a long-term ECG monitoring period, whether to replace a dislodged electrode, reestablish better adhesion, alleviate itching or irritation, allow for cleansing of the skin, allow for showering and exercise, or for other purpose. Such replacement or slight alteration in electrode location actually facilitates the goal of recording the ECG signal for long periods of time.

[0011] Conventionally, multi-week or multi-month monitoring can be performed by implantable ECG monitors, such as the Reveal LINQ insertable cardiac monitor, manufactured by Medtronic, Inc., Minneapolis, Minn. This monitor can detect and record paroxysmal or asymptomatic arrhythmias for up to three years. However, like all forms of implantable medical device (IMD), use of this monitor requires invasive surgical implantation, which significantly increases costs; requires ongoing follow up by a physician throughout the period of implantation; requires specialized equipment to retrieve monitoring data; and carries complications attendant to all surgery, including risks of infection, injury or death.

[0012] Holter monitors are widely used for extended ECG monitoring. Typically, they are often used for only 24-48 hours. A typical Holter monitor is a wearable and portable version of an ECG that include cables for each electrode placed on the skin and a separate battery-powered ECG recorder. The leads are placed in the anterior thoracic region in a manner similar to what is done with an in-clinic standard ECG machine using electrode locations that are not specifically intended for optimal P-wave capture. The duration of

monitoring depends on the sensing and storage capabilities of the monitor. A "looping" Holter (or event) monitor can operate for a longer period of time by overwriting older ECG tracings, thence "recycling" storage in favor of extended operation, yet at the risk of losing event data. Although capable of extended ECG monitoring, Holter monitors are cumbersome, expensive and typically only available by medical prescription, which limits their usability. Further, the skill required to properly place the electrodes on the patient's chest precludes a patient from replacing or removing the sensing leads and usually involves moving the patient from the physician office to a specialized center within the hospital or clinic.

[0013] U.S. Pat. No. 8,460,189, to Libbus et al. ("Libbus") discloses an adherent wearable cardiac monitor that includes at least two measurement electrodes and an accelerometer. The device includes a reusable electronics module and a disposable adherent patch that includes the electrodes. ECG monitoring can be conducted using multiple disposable patches adhered to different locations on the patient's body. The device includes a processor configured to control collection and transmission of data from ECG circuitry, including generating and processing of ECG signals and data acquired from two or more electrodes. The ECG circuitry can be coupled to the electrodes in many ways to define an ECG vector, and the orientation of the ECG vector can be determined in response to the polarity of the measurement electrodes and orientation of the electrode measurement axis. The accelerometer can be used to determine the orientation of the measurement electrodes in each of the locations. The ECG signals measured at different locations can be rotated based on the accelerometer data to modify amplitude and direction of the ECG features to approximate a standard ECG vector. The signals recorded at different locations can be combined by summing a scaled version of each signal. Libbus further discloses that inner ECG electrodes may be positioned near outer electrodes to increase the voltage of measured ECG signals. However, Libbus treats ECG signal acquisition as the measurement of a simple aggregate directional data signal without differentiating between the distinct kinds of cardiac electrical activities presented with an ECG waveform, particularly atrial (P-wave) activity.

[0014] The ZIO XT Patch and ZIO Event Card devices, manufactured by iRhythm Tech., Inc., San Francisco, Calif., are wearable monitoring devices that are typically worn on the upper left pectoral region to respectively provide continuous and looping ECG recording. The location is used to simulate surgically implanted monitors, but without specifically enhancing P-wave capture. Both of these devices are prescription-only and for single patient use. The ZIO XT Patch device is limited to a 14-day period, while the electrodes only of the ZIO Event Card device can be worn for up to 30 days. The ZIO XT Patch device combines both electronic recordation components and physical electrodes into a unitary assembly that adheres to the patient's skin. The ZIO XT Patch device uses adhesive sufficiently strong to support the weight of both the monitor and the electrodes over an extended period and to resist disadherence from the patient's body, albeit at the cost of disallowing removal or relocation during the monitoring period. The ZIO Event Card device is a form of downsized Holter monitor with a recorder component that must be removed temporarily during baths or other activities that could damage the non-

waterproof electronics. Both devices represent compromises between length of wear and quality of ECG monitoring, especially with respect to ease of long term use, female-friendly fit, and quality of cardiac electrical potential signals, especially atrial (P-wave) signals.

[0015] Therefore, a need remains for a low cost extended wear continuously recording ECG monitor attuned to capturing low amplitude cardiac action potential propagation for arrhythmia diagnosis, particularly atrial activation P-waves, and practicably capable of being worn for a long period of time, especially in patient's whose breast anatomy or size can interfere with signal quality in both women and men.

SUMMARY

[0016] Physiological monitoring can be provided through a lightweight wearable monitor that includes two components, a flexible extended wear electrode patch and a reusable monitor recorder that removably snaps into a receptacle on the electrode patch. The wearable monitor sits centrally (in the midline) on the patient's chest along the sternum oriented top-to-bottom. The ECG electrodes on the electrode patch are tailored to be positioned axially along the midline of the sternum for capturing action potential propagation in an orientation that corresponds to the aVF lead used in a conventional 12-lead ECG that is used to sense positive or upright P-waves. The placement of the wearable monitor in a location at the sternal midline (or immediately to either side of the sternum), with its unique narrow "hourglass"-like shape, significantly improves the ability of the wearable monitor to cutaneously sense cardiac electrical potential signals, particularly the P-wave (or atrial activity) and, to a lesser extent, the QRS interval signals indicating ventricular activity in the ECG waveforms.

[0017] Moreover, the electrocardiography monitor offers superior patient comfort, convenience and user-friendliness. The electrode patch is specifically designed for ease of use by a patient (or caregiver); assistance by professional medical personnel is not required. The patient is free to replace the electrode patch at any time and need not wait for a doctor's appointment to have a new electrode patch placed. Patients can easily be taught to find the familiar physical landmarks on the body necessary for proper placement of the electrode patch. Empowering patients with the knowledge to place the electrode patch in the right place ensures that the ECG electrodes will be correctly positioned on the skin, no matter the number of times that the electrode patch is replaced. In addition, the monitor recorder operates automatically and the patient only need snap the monitor recorder into place on the electrode patch to initiate ECG monitoring. Thus, the synergistic combination of the electrode patch and monitor recorder makes the use of the electrocardiography monitor a reliable and virtually fool-proof way to monitor a patient's ECG and physiology for an extended, or even open-ended, period of time.

[0018] In one embodiment, an extended wear sewn electrode electrocardiography monitor is provided. The monitor includes an extended wear electrocardiography patch. The patch includes a flexible backing formed of an elongated strip of stretchable material with narrow longitudinal midsection evenly tapering inward from a distal end and a proximal end, the elongated strip adherable only to a contact surface defined on each of the ends; a pair of flexile wires, one of the wires forming an electrocardiographic electrode,

the electrocardiographic electrode formed by a portion of the one wire that is sewn into the distal end of the elongated strip and that is configured for directly contacting the patient, the one wire continuing back along an axial path through the midsection, another one of the wires forming another electrocardiographic electrode, the another electrocardiographic electrode formed by a portion of the another wire that is sewn into the proximal end of the elongated strip and that is configured for electrically contacting the patient, each of the electrodes including an electrically conductive area only exposed on the contact surface; and a circuit board affixed on one of the ends of the elongated strip and connected to both of the flexile wires and comprising one or more electrical contact mating pads operable to electrically couple an electrocardiography monitor with the pair of the electrodes.

[0019] A further embodiment provides an extended wear electrocardiography patch with wire electrode assemblies. A battery printed circuit board is affixed on a proximal end of a flexible backing. A distal electrode assembly includes a distal wire, a portion of which is affixed to a distal end of the flexible backing and configured in a pattern. A further portion of the distal wire is interlaced along the flexible backing and connected to the battery printed circuit board. A proximal electrode assembly includes a proximal wire configured in a pattern on the proximal end of the flexible backing and connected to the battery printed circuit board.

[0020] A still further embodiment provides an extended wear electrocardiography monitor with wire electrode assemblies. An electrocardiography patch includes a flexible backing and a battery printed circuit board affixed on a proximal end of the flexible backing. A distal electrode assembly includes a distal wire, a portion of which is affixed to a distal end of the flexible backing and configured in a pattern. A further portion of the distal wire is interlaced along the flexible backing and connected to the battery printed circuit board. A proximal electrode assembly includes a proximal wire configured in a pattern on the proximal end of the flexible backing and connected to the battery printed circuit board. An electrocardiography monitor recorder includes a sealed housing shaped to be removably attached to the electrocardiography patch and an externally-powered micro-controller. An electrocardiographic front end circuit is interfaced to the micro-controller and operable to sense electrocardiographic signals through the distal and proximal wires.

[0021] The foregoing aspects enhance ECG monitoring performance and quality by facilitating long-term ECG recording, which is critical to accurate arrhythmia and cardiac rhythm disorder diagnoses.

[0022] The monitoring patch is especially suited to the female anatomy, although also easily used over the male sternum. The narrow longitudinal midsection can fit nicely within the inter-mammary cleft of the breasts without inducing discomfort, whereas conventional patch electrodes are wide and, if adhered between the breasts, would cause chafing, irritation, discomfort, and annoyance, leading to low patient compliance.

[0023] In addition, the foregoing aspects enhance comfort in women (and certain men), but not irritation of the breasts, by placing the monitoring patch in the best location possible for optimizing the recording of cardiac signals from the atrium, particularly P-waves, which is another feature critical to proper arrhythmia and cardiac rhythm disorder diagnoses.

[0024] Still other embodiments will become readily apparent to those skilled in the art from the following detailed description, wherein are described embodiments by way of illustrating the best mode contemplated. As will be realized, other and different embodiments are possible and the embodiments' several details are capable of modifications in various obvious respects, all without departing from their spirit and the scope. Accordingly, the drawings and detailed description are to be regarded as illustrative in nature and not as restrictive.

BRIEF DESCRIPTION OF THE DRAWINGS

[0025] FIGS. 1 and 2 are diagrams showing, by way of examples, an extended wear electrocardiography monitor, including an extended wear electrode patch, in accordance with one embodiment, respectively fitted to the sternal region of a female patient and a male patient.

[0026] FIG. 3 is a front anatomical view showing, by way of illustration, the locations of the heart and lungs within the rib cage of an adult human.

[0027] FIG. 4 is a perspective view showing an extended wear electrode patch in accordance with one embodiment with a monitor recorder inserted.

[0028] FIG. 5 is a perspective view showing the monitor recorder of FIG. 4.

[0029] FIG. 6 is a perspective view showing the extended wear electrode patch of FIG. 4 without a monitor recorder inserted.

[0030] FIG. 7 is a bottom plan view of the monitor recorder of FIG. 4.

[0031] FIG. 8 is a top view showing the flexible circuit of the extended wear electrode patch of FIG. 4.

[0032] FIG. 9 is a functional block diagram showing the component architecture of the circuitry of the monitor recorder of FIG. 4.

[0033] FIG. 10 is a functional block diagram showing the circuitry of the extended wear electrode patch of FIG. 4.

[0034] FIG. 11 is a schematic diagram showing the ECG front end circuit of the circuitry of the monitor recorder of FIG. 9.

[0035] FIG. 12 is a flow diagram showing a monitor recorder-implemented method for monitoring ECG data for use in the monitor recorder of FIG. 4.

[0036] FIG. 13 is a graph showing, by way of example, a typical ECG waveform.

[0037] FIG. 14 is a functional block diagram showing the signal processing functionality of the microcontroller.

[0038] FIG. 15 is a functional block diagram showing the operations performed by the download station.

[0039] FIGS. 16A-C are functional block diagrams respectively showing practical uses of the extended wear electrocardiography monitors of FIGS. 1 and 2.

[0040] FIG. 17 is a perspective view of an extended wear electrode patch with a flexile wire electrode assembly in accordance with a still further embodiment.

[0041] FIG. 18 is perspective view of the flexile wire electrode assembly from FIG. 17, with a layer of insulating material shielding a bare distal wire around the midsection of the flexible backing.

[0042] FIG. 19 is a bottom view of the flexile wire electrode assembly as shown in FIG. 17.

[0043] FIG. 20 is a bottom view of a flexile wire electrode assembly in accordance with a still yet further embodiment.

[0044] FIG. 21 is a perspective view showing the longitudinal midsection of the flexible backing of the electrode assembly from FIG. 17.

DETAILED DESCRIPTION

[0045] ECG and physiological monitoring can be provided through a wearable ambulatory monitor that includes two components, a flexible extended wear electrode patch and a removable reusable (or single use) monitor recorder. Both the electrode patch and the monitor recorder are optimized to capture electrical signals from the propagation of low amplitude, relatively low frequency content cardiac action potentials, particularly the P-waves generated during atrial activation. FIGS. 1 and 2 are diagrams showing, by way of examples, an extended wear electrocardiography monitor 12, including a monitor recorder 14, in accordance with one embodiment, respectively fitted to the sternal region of a female patient 10 and a male patient 11. The wearable monitor 12 sits centrally, positioned axially along the sternal midline 16, on the patient's chest along the sternum 13 and oriented top-to-bottom with the monitor recorder 14 preferably situated towards the patient's head. In a further embodiment, the orientation of the wearable monitor 12 can be corrected post-monitoring, as further described infra, for instance, if the wearable monitor 12 is inadvertently fitted upside down.

[0046] The electrode patch 15 is shaped to fit comfortably and conformal to the contours of the patient's chest approximately centered on the sternal midline 16 (or immediately to either side of the sternum 13). The distal end of the electrode patch 15, under which a lower or inferior pole (ECG electrode) is adhered, extends towards the Xiphoid process and lower sternum and, depending upon the patient's build, may straddle the region over the Xiphoid process and lower sternum. The proximal end of the electrode patch 15, located under the monitor recorder 14, under which an upper or superior pole (ECG electrode) is adhered, is below the manubrium and, depending upon patient's build, may straddle the region over the manubrium.

[0047] During ECG monitoring, the amplitude and strength of action potentials sensed on the body's surface are affected to varying degrees by cardiac, cellular, extracellular, vector of current flow, and physical factors, like obesity, dermatitis, large breasts, and high impedance skin, as can occur in dark-skinned individuals. Sensing along the sternal midline 16 (or immediately to either side of the sternum 13) significantly improves the ability of the wearable monitor 12 to cutaneously sense cardiac electric signals, particularly the P-wave (or atrial activity) and, to a lesser extent, the QRS interval signals in the ECG waveforms that indicate ventricular activity by countering some of the effects of these factors.

[0048] The ability to sense low amplitude, low frequency content body surface potentials is directly related to the location of ECG electrodes on the skin's surface and the ability of the sensing circuitry to capture these electrical signals. FIG. 3 is a front anatomical view showing, by way of illustration, the locations of the heart 4 and lungs 5 within the rib cage of an adult human. Depending upon their placement locations on the chest, ECG electrodes may be separated from activation regions within the heart 4 by differing combinations of internal tissues and body structures, including heart muscle, intracardiac blood, the pericardium, intrathoracic blood and fluids, the lungs 5, skeletal

muscle, bone structure, subcutaneous fat, and the skin, plus any contaminants present between the skin's surface and electrode signal pickups. The degree of amplitude degradation of cardiac transmembrane potentials increases with the number of tissue boundaries between the heart **4** and the skin's surface that are encountered. The cardiac electrical field is degraded each time the transmembrane potentials encounter a physical boundary separating adjoining tissues due to differences in the respective tissues' electrical resistances. In addition, other non-spatial factors, such as pericardial effusion, emphysema or fluid accumulation in the lungs, as further explained infra, can further degrade body surface potentials.

[0049] Internal tissues and body structures can adversely affect the current strength and signal fidelity of all body surface potentials, yet low amplitude cardiac action potentials, particularly the P-wave with a normative amplitude of less than 0.25 microvolts (mV) and a normative duration of less than 120 milliseconds (ms), are most apt to be negatively impacted. The atria **6** are generally located posteriorly within the thoracic cavity (with the exception of the anterior right atrium and right atrial appendage), and, physically, the left atrium constitutes the portion of the heart **4** furthest away from the surface of the skin on the chest. Conversely, the ventricles **7**, which generate larger amplitude signals, generally are located anteriorly with the anterior right ventricle and most of the left ventricle situated relatively close to the skin surface on the chest, which contributes to the relatively stronger amplitudes of ventricular waveforms. Thus, the quality of P-waves (and other already-low amplitude action potential signals) is more susceptible to weakening from intervening tissues and structures than the waveforms associated with ventricular activation.

[0050] The importance of the positioning of ECG electrodes along the sternal midline **15** has largely been overlooked by conventional approaches to ECG monitoring, in part due to the inability of their sensing circuitry to reliably detect low amplitude, low frequency content electrical signals, particularly in P-waves. In turn, that inability to keenly sense P-waves has motivated ECG electrode placement in other non-sternal midline thoracic locations, where the QRSTU components that represent ventricular electrical activity are more readily detectable by their sensing circuitry than P-waves. In addition, ECG electrode placement along the sternal midline **15** presents major patient wearability challenges, such as fitting a monitoring ensemble within the narrow confines of the inter-mammary cleft between the breasts, that to large extent drive physical packaging concerns, which can be incompatible with ECG monitors intended for placement, say, in the upper pectoral region or other non-sternal midline thoracic locations. In contrast, the wearable monitor **12** uses an electrode patch **15** that is specifically intended for extended wear placement in a location at the sternal midline **16** (or immediately to either side of the sternum **13**). When combined with a monitor recorder **14** that uses sensing circuitry optimized to preserve the characteristics of low amplitude cardiac action potentials, especially those signals from the atria, as further described infra with reference to FIG. **11**, the electrode patch **15** helps to significantly improve atrial activation (P-wave) sensing through placement in a body location that robustly minimizes the effects of tissue and body structure.

[0051] Referring back to FIGS. **1** and **2**, the placement of the wearable monitor **12** in the region of the sternal midline

13 puts the ECG electrodes of the electrode patch **15** in locations better adapted to sensing and recording low amplitude cardiac action potentials during atrial propagation (P-wave signals) than placement in other locations, such as the upper left pectoral region, as commonly seen in most conventional ambulatory ECG monitors. The sternum **13** overlies the right atrium of the heart **4**. As a result, action potential signals have to travel through fewer layers of tissue and structure to reach the ECG electrodes of the electrode patch **15** on the body's surface along the sternal midline **13** when compared to other monitoring locations, a distinction that is of critical importance when capturing low frequency content electrical signals, such as P-waves.

[0052] Moreover, cardiac action potential propagation travels simultaneously along a north-to-south and right-to-left vector, beginning high in the right atrium and ultimately ending in the posterior and lateral region of the left ventricle. Cardiac depolarization originates high in the right atrium in the SA node before concurrently spreading leftward towards the left atrium and inferiorly towards the AV node. The ECG electrodes of the electrode patch **15** are placed with the upper or superior pole (ECG electrode) along the sternal midline **13** in the region of the manubrium and the lower or inferior pole (ECG electrode) along the sternal midline **13** in the region of the Xiphoid process **9** and lower sternum. The ECG electrodes are placed primarily in a north-to-south orientation along the sternum **13** that corresponds to the north-to-south waveform vector exhibited during atrial activation. This orientation corresponds to the aVF lead used in a conventional 12-lead ECG that is used to sense positive or upright P-waves.

[0053] Furthermore, the thoracic region underlying the sternum **13** along the midline **16** between the manubrium **8** and Xiphoid process **9** is relatively free of lung tissue, musculature, and other internal body structures that could occlude the electrical signal path between the heart **4**, particularly the atria, and ECG electrodes placed on the surface of the skin. Fewer obstructions means that cardiac electrical potentials encounter fewer boundaries between different tissues. As a result, when compared to other thoracic ECG sensing locations, the cardiac electrical field is less altered when sensed dermally along the sternal midline **13**. As well, the proximity of the sternal midline **16** to the ventricles **7** facilitates sensing of right ventricular activity and provides superior recordation of the QRS interval, again, in part due to the relatively clear electrical path between the heart **4** and the skin surface.

[0054] Finally, non-spatial factors can affect transmembrane action potential shape and conductivity. For instance, myocardial ischemia, an acute cardiac condition, can cause a transient increase in blood perfusion in the lungs **5**. The perfused blood can significantly increase electrical resistance across the lungs **5** and therefore degrade transmission of the cardiac electrical field to the skin's surface. However, the placement of the wearable monitor **12** along the sternal midline **16** in the inter-mammary cleft between the breasts is relatively resilient to the adverse effects to cardiac action potential degradation caused by ischemic conditions as the body surface potentials from a location relatively clear of underlying lung tissue and fat help compensate for the loss of signal amplitude and content. The monitor recorder **14** is thus able to record the P-wave morphology that may be compromised by myocardial ischemia and therefore make

diagnosis of the specific arrhythmias that can be associated with myocardial ischemia more difficult.

[0055] During use, the electrode patch 15 is first adhered to the skin along the sternal midline 16 (or immediately to either side of the sternum 13). A monitor recorder 14 is then snapped into place on the electrode patch 15 using an electro-mechanical docking interface to initiate ECG monitoring. FIG. 4 is a perspective view showing an extended wear electrode patch 15 in accordance with one embodiment with a monitor recorder 14 inserted. The body of the electrode patch 15 is preferably constructed using a flexible backing 20 formed as an elongated strip 21 of wrap knit or similar stretchable material about 145 mm long and 32 mm at the widest point with a narrow longitudinal mid-section 23 evenly tapering inward from both sides. A pair of cut-outs 22 between the distal and proximal ends of the electrode patch 15 create a narrow longitudinal midsection 23 or “isthmus” and defines an elongated “hourglass”-like shape, when viewed from above, such as described in commonly-assigned U.S. Design Pat. No. D744,659, issued Dec. 1, 2015, the disclosure of which is incorporated by reference. The upper part of the “hourglass” is sized to allow an electrically non-conductive receptacle 25, sits on top of the outward-facing surface of the electrode patch 15, to be affixed to the electrode patch 15 with an ECG electrode placed underneath on the patient-facing underside, or contact, surface of the electrode patch 15; the upper part of the “hourglass” has a longer and wider profile (but still rounded and tapered to fit comfortably between the breasts) than the lower part of the “hourglass,” which is sized primarily to allow just the placement of an ECG electrode of appropriate shape and surface area to record the P-wave and the QRS signals sufficiently given the inter-electrode spacing.

[0056] The electrode patch 15 incorporates features that significantly improve wearability, performance, and patient comfort throughout an extended monitoring period. The entire electrode patch 15 is lightweight in construction, which allows the patch to be resilient to disadhering or falling off and, critically, to avoid creating distracting discomfort to the patient, even when the patient is asleep. In contrast, the weight of a heavy ECG monitor impedes patient mobility and will cause the monitor to constantly tug downwards and press on the patient’s body that can generate skin inflammation with frequent adjustments by the patient needed to maintain comfort.

[0057] During everyday wear, the electrode patch 15 is subjected to pushing, pulling, and torsional movements, including compressional and torsional forces when the patient bends forward, or tensile and torsional forces when the patient leans backwards. To counter these stress forces, the electrode patch 15 incorporates crimp and strain reliefs, such as described in commonly-assigned U.S. Pat. No. 9,545,204, issued Jan. 17, 2017, the disclosure of which is incorporated by reference. In addition, the cut-outs 22 and longitudinal midsection 23 help minimize interference with and discomfort to breast tissue, particularly in women (and gynecomastic men). The cut-outs 22 and longitudinal midsection 23 further allow better conformity of the electrode patch 15 to sternal bowing and to the narrow isthmus of flat skin that can occur along the bottom of the inter-mammary cleft between the breasts, especially in buxom women. The cut-outs 22 and narrow and flexible longitudinal midsection 23 help the electrode patch 15 fit nicely between a pair of female breasts in the inter-mammary cleft. In one embodi-

ment, the cut-outs 22 can be graduated to form the longitudinal midsection 23 as a narrow in-between stem or isthmus portion about 7 mm wide. In a still further embodiment, tabs 24 can respectively extend an additional 8 mm to 12 mm beyond the distal and proximal ends of the flexible backing 20 to facilitate with adhering the electrode patch 15 to or removing the electrode patch 15 from the sternum 13. These tabs preferably lack adhesive on the underside, or contact, surface of the electrode patch 15. Still other shapes, cut-outs and conformities to the electrode patch 15 are possible.

[0058] The monitor recorder 14 removably and reusablely snaps into an electrically non-conductive receptacle 25 during use. The monitor recorder 14 contains electronic circuitry for recording and storing the patient’s electrocardiography as sensed via a pair of ECG electrodes provided on the electrode patch 15, as further described infra beginning with reference to FIG. 9. The non-conductive receptacle 25 is provided on the top surface of the flexible backing 20 with a retention catch 26 and tension clip 27 molded into the non-conductive receptacle 25 to conformably receive and securely hold the monitor recorder 14 in place.

[0059] The monitor recorder 14 includes a sealed housing that snaps into place in the non-conductive receptacle 25. FIG. 5 is a perspective view showing the monitor recorder 14 of FIG. 4. The sealed housing 50 of the monitor recorder 14 intentionally has a rounded isosceles trapezoidal-like shape 52, when viewed from above, such as described in commonly-assigned U.S. Design Pat. No. D717,955, issued Nov. 18, 2014, the disclosure of which is incorporated by reference. The edges 51 along the top and bottom surfaces are rounded for patient comfort. The sealed housing 50 is approximately 47 mm long, 23 mm wide at the widest point, and 7 mm high, excluding a patient-operable tactile-feedback button 55. The sealed housing 50 can be molded out of polycarbonate, ABS, or an alloy of those two materials. The button 55 is waterproof and the button’s top outer surface is molded silicon rubber or similar soft pliable material. A retention detent 53 and tension detent 54 are molded along the edges of the top surface of the housing 50 to respectively engage the retention catch 26 and the tension clip 27 molded into non-conductive receptacle 25. Other shapes, features, and conformities of the sealed housing 50 are possible.

[0060] The electrode patch 15 is intended to be disposable, while the monitor recorder 14 is designed for reuse and can be transferred to successive electrode patches 15 to ensure continuity of monitoring, if so desired. The monitor recorder 14 can be used only once, but single use effectively wastes the synergistic benefits provided by the combination of the disposable electrode patch and reusable monitor recorder, as further explained infra with reference to FIGS. 16A-C. The placement of the wearable monitor 12 in a location at the sternal midline 16 (or immediately to either side of the sternum 13) benefits long-term extended wear by removing the requirement that ECG electrodes be continually placed in the same spots on the skin throughout the monitoring period. Instead, the patient is free to place an electrode patch 15 anywhere within the general region of the sternum 13.

[0061] As a result, at any point during ECG monitoring, the patient’s skin is able to recover from the wearing of an electrode patch 15, which increases patient comfort and satisfaction, while the monitor recorder 14 ensures ECG monitoring continuity with minimal effort. A monitor recorder 14 is merely unsnapped from a worn out electrode

patch 15, the worn out electrode patch 15 is removed from the skin, a new electrode patch 15 is adhered to the skin, possibly in a new spot immediately adjacent to the earlier location, and the same monitor recorder 14 is snapped into the new electrode patch 15 to reinitiate and continue the ECG monitoring.

[0062] During use, the electrode patch 15 is first adhered to the skin in the sternal region. FIG. 6 is a perspective view showing the extended wear electrode patch 15 of FIG. 4 without a monitor recorder 14 inserted. A flexible circuit 32 is adhered to each end of the flexible backing 20. A distal circuit trace 33 from the distal end 30 of the flexible backing 20 and a proximal circuit trace (not shown) from the proximal end 31 of the flexible backing 20 electrically couple ECG electrodes (not shown) with a pair of electrical pads 34. In a further embodiment, the distal and proximal circuit traces are replaced with interlaced or sewn-in flexible wires, as further described infra beginning with reference to FIG. 17. The electrical pads 34 are provided within a moisture-resistant seal 35 formed on the bottom surface of the non-conductive receptacle 25. When the monitor recorder 14 is securely received into the non-conductive receptacle 25, that is, snapped into place, the electrical pads 34 interface to electrical contacts (not shown) protruding from the bottom surface of the monitor recorder 14. The moisture-resistant seal 35 enables the monitor recorder 14 to be worn at all times, even during showering or other activities that could expose the monitor recorder 14 to moisture or adverse conditions.

[0063] In addition, a battery compartment 36 is formed on the bottom surface of the non-conductive receptacle 25. A pair of battery leads (not shown) from the battery compartment 36 to another pair of the electrical pads 34 electrically interface the battery to the monitor recorder 14. The battery contained within the battery compartment 35 is a direct current (DC) power cell and can be replaceable, rechargeable or disposable.

[0064] The monitor recorder 14 draws power externally from the battery provided in the non-conductive receptacle 25, thereby uniquely obviating the need for the monitor recorder 14 to carry a dedicated power source. FIG. 7 is a bottom plan view of the monitor recorder 14 of FIG. 4. A cavity 58 is formed on the bottom surface of the sealed housing 50 to accommodate the upward projection of the battery compartment 36 from the bottom surface of the non-conductive receptacle 25, when the monitor recorder 14 is secured in place on the non-conductive receptacle 25. A set of electrical contacts 56 protrude from the bottom surface of the sealed housing 50 and are arranged in alignment with the electrical pads 34 provided on the bottom surface of the non-conductive receptacle 25 to establish electrical connections between the electrode patch 15 and the monitor recorder 14. In addition, a seal coupling 57 circumferentially surrounds the set of electrical contacts 56 and securely mates with the moisture-resistant seal 35 formed on the bottom surface of the non-conductive receptacle 25. The battery contained within the battery compartment 36 can be replaceable, rechargeable or disposable. In a further embodiment, the ECG sensing circuitry of the monitor recorder 14 can be supplemented with additional sensors, including an SpO₂ sensor, a blood pressure sensor, a temperature sensor, respiratory rate sensor, a glucose sensor, an air flow sensor, and

a volumetric pressure sensor, which can be incorporated directly into the monitor recorder 14 or onto the non-conductive receptacle 25.

[0065] The placement of the flexible backing 20 on the sternal midline 16 (or immediately to either side of the sternum 13) also helps to minimize the side-to-side movement of the wearable monitor 12 in the left- and right-handed directions during wear. However, the wearable monitor 12 is still susceptible to pushing, pulling, and torquing movements, including compressional and torsional forces when the patient bends forward, and tensile and torsional forces when the patient leans backwards or twists. To counter the dislodgment of the flexible backing 20 due to compressional and torsional forces, a layer of non-irritating adhesive, such as hydrocolloid, is provided at least partially on the underside, or contact, surface of the flexible backing 20, but only on the distal end 30 and the proximal end 31. As a result, the underside, or contact surface of the longitudinal midsection 23 does not have an adhesive layer and remains free to move relative to the skin. Thus, the longitudinal midsection 23 forms a crimp relief that respectively facilitates compression and twisting of the flexible backing 20 in response to compressional and torsional forces. Other forms of flexible backing crimp reliefs are possible.

[0066] Unlike the flexible backing 20, the flexible circuit 32 is only able to bend and cannot stretch in a planar direction. The flexible circuit 32 can be provided either above or below the flexible backing 20. FIG. 8 is a top view showing the flexible circuit 32 of the extended wear electrode patch 15 of FIG. 4 when mounted above the flexible backing 20. A distal ECG electrode 38 and proximal ECG electrode 39 are respectively coupled to the distal and proximal ends of the flexible circuit 32 to serve as electrode signal pickups. The flexible circuit 32 preferably does not extend to the outside edges of the flexible backing 20, thereby avoiding gouging or discomforting the patient's skin during extended wear, such as when sleeping on the side. During wear, the ECG electrodes 38, 39 must remain in continual contact with the skin. A strain relief 40 is defined in the flexible circuit 32 at a location that is partially underneath the battery compartment 36 when the flexible circuit 32 is affixed to the flexible backing 20. The strain relief 40 is laterally extendable to counter dislodgment of the ECG electrodes 38, 39 due to bending, tensile and torsional forces. A pair of strain relief cutouts 41 partially extend transversely from each opposite side of the flexible circuit 32 and continue longitudinally towards each other to define in 'S'-shaped pattern, when viewed from above. The strain relief respectively facilitates longitudinal extension and twisting of the flexible circuit 32 in response to tensile and torsional forces. Other forms of circuit board strain relief are possible.

[0067] ECG monitoring and other functions performed by the monitor recorder 14 are provided through a micro controlled architecture. FIG. 9 is a functional block diagram showing the component architecture of the circuitry 60 of the monitor recorder 14 of FIG. 4. The circuitry 60 is externally powered through a battery provided in the non-conductive receptacle 25 (shown in FIG. 6). Both power and raw ECG signals, which originate in the pair of ECG electrodes 38, 39 (shown in FIG. 8) on the distal and proximal ends of the electrode patch 15, are received through an external connector 65 that mates with a corresponding physical connector on the electrode patch 15. The

external connector **65** includes the set of electrical contacts **56** that protrude from the bottom surface of the sealed housing **50** and which physically and electrically interface with the set of pads **34** provided on the bottom surface of the non-conductive receptacle **25**. The external connector includes electrical contacts **56** for data download, microcontroller communications, power, analog inputs, and a peripheral expansion port. The arrangement of the pins on the electrical connector **65** of the monitor recorder **14** and the device into which the monitor recorder **14** is attached, whether an electrode patch **15** or download station (not shown), follow the same electrical pin assignment convention to facilitate interoperability. The external connector **65** also serves as a physical interface to a download station that permits the retrieval of stored ECG monitoring data, communication with the monitor recorder **14**, and performance of other functions. The download station is further described infra with reference to FIG. **15**.

[0068] Operation of the circuitry **60** of the monitor recorder **14** is managed by a microcontroller **61**, such as the EFM32 Tiny Gecko 32-bit microcontroller, manufactured by Silicon Laboratories Inc., Austin, Tex. The microcontroller **61** has flexible energy management modes and includes a direct memory access controller and built-in analog-to-digital and digital-to-analog converters (ADC and DAC, respectively). The microcontroller **61** also includes a program memory unit containing internal flash memory that is readable and writable. The internal flash memory can also be programmed externally. The microcontroller **61** operates under modular micro program control as specified in firmware stored in the internal flash memory. The functionality and firmware modules relating to signal processing by the microcontroller **61** are further described infra with reference to FIG. **14**. The microcontroller **61** draws power externally from the battery provided on the electrode patch **15** via a pair of the electrical contacts **56**. The microcontroller **61** connects to the ECG front end circuit **63** that measures raw cutaneous electrical signals using a driven reference that eliminates common mode noise, as further described infra with reference to FIG. **11**.

[0069] The circuitry **60** of the monitor recorder **14** also includes a flash memory **62**, which the microcontroller **61** uses for storing ECG monitoring data and other physiology and information. The flash memory **62** also draws power externally from the battery provided on the electrode patch **15** via a pair of the electrical contacts **56**. Data is stored in a serial flash memory circuit, which supports read, erase and program operations over a communications bus. The flash memory **62** enables the microcontroller **61** to store digitized ECG data. The communications bus further enables the flash memory **62** to be directly accessed externally over the external connector **65** when the monitor recorder **14** is interfaced to a download station.

[0070] The microcontroller **61** includes functionality that enables the acquisition of samples of analog ECG signals, which are converted into a digital representation, as further described infra with reference to FIG. **14**. In one mode, the microcontroller **61** will acquire, sample, digitize, signal process, and store digitized ECG data into available storage locations in the flash memory **62** until all memory storage locations are filled, after which the digitized ECG data needs to be downloaded or erased to restore memory capacity. Data download or erasure can also occur before all storage locations are filled, which would free up memory space

sooner, albeit at the cost of possibly interrupting monitoring while downloading or erasure is performed. In another mode, the microcontroller **61** can include a loop recorder feature that will overwrite the oldest stored data once all storage locations are filled, albeit at the cost of potentially losing the stored data that was overwritten, if not previously downloaded. Still other modes of data storage and capacity recovery are possible.

[0071] The circuitry **60** of the monitor recorder **14** further includes an actigraphy sensor **64** implemented as a 3-axis accelerometer. The accelerometer may be configured to generate interrupt signals to the microcontroller **61** by independent initial wake up and free fall events, as well as by device position. In addition, the actigraphy provided by the accelerometer can be used during post-monitoring analysis to correct the orientation of the monitor recorder **14** if, for instance, the monitor recorder **14** has been inadvertently installed upside down, that is, with the monitor recorder **14** oriented on the electrode patch **15** towards the patient's feet, as well as for other event occurrence analyses.

[0072] The microcontroller **61** includes an expansion port that also utilizes the communications bus. External devices, separately drawing power externally from the battery provided on the electrode patch **15** or other source, can interface to the microcontroller **61** over the expansion port in half duplex mode. For instance, an external physiology sensor can be provided as part of the circuitry **60** of the monitor recorder **14**, or can be provided on the electrode patch **15** with communication with the microcontroller **61** provided over one of the electrical contacts **56**. The physiology sensor can include an SpO₂ sensor, blood pressure sensor, temperature sensor, respiratory rate sensor, glucose sensor, airflow sensor, volumetric pressure sensing, or other types of sensor or telemetric input sources. In a further embodiment, a wireless interface for interfacing with other wearable (or implantable) physiology monitors, as well as data offload and programming, can be provided as part of the circuitry **60** of the monitor recorder **14**, or can be provided on the electrode patch **15** with communication with the microcontroller **61** provided over one of the electrical contacts **56**.

[0073] Finally, the circuitry **60** of the monitor recorder **14** includes patient-interfaceable components, including a tactile feedback button **66**, which a patient can press to mark events or to perform other functions, and a buzzer **67**, such as a speaker, magnetic resonator or piezoelectric buzzer. The buzzer **67** can be used by the microcontroller **61** to output feedback to a patient such as to confirm power up and initiation of ECG monitoring. Still other components as part of the circuitry **60** of the monitor recorder **14** are possible.

[0074] While the monitor recorder **14** operates under micro control, most of the electrical components of the electrode patch **15** operate passively. FIG. **10** is a functional block diagram showing the circuitry **70** of the extended wear electrode patch **15** of FIG. **4**. The circuitry **70** of the electrode patch **15** is electrically coupled with the circuitry **60** of the monitor recorder **14** through an external connector **74**. The external connector **74** is terminated through the set of pads **34** provided on the bottom of the non-conductive receptacle **25**, which electrically mate to corresponding electrical contacts **56** protruding from the bottom surface of the sealed housing **50** to electrically interface the monitor recorder **14** to the electrode patch **15**.

[0075] The circuitry **70** of the electrode patch **15** performs three primary functions. First, a battery **71** is provided in a

battery compartment formed on the bottom surface of the non-conductive receptacle 25. The battery 71 is electrically interfaced to the circuitry 60 of the monitor recorder 14 as a source of external power. The unique provisioning of the battery 71 on the electrode patch 15 provides several advantages. First, the locating of the battery 71 physically on the electrode patch 15 lowers the center of gravity of the overall wearable monitor 12 and thereby helps to minimize shear forces and the effects of movements of the patient and clothing. Moreover, the housing 50 of the monitor recorder 14 is sealed against moisture and providing power externally avoids having to either periodically open the housing 50 for the battery replacement, which also creates the potential for moisture intrusion and human error, or to recharge the battery, which can potentially take the monitor recorder 14 off line for hours at a time. In addition, the electrode patch 15 is intended to be disposable, while the monitor recorder 14 is a reusable component. Each time that the electrode patch 15 is replaced, a fresh battery is provided for the use of the monitor recorder 14, which enhances ECG monitoring performance quality and duration of use. Also, the architecture of the monitor recorder 14 is open, in that other physiology sensors or components can be added by virtue of the expansion port of the microcontroller 61. Requiring those additional sensors or components to draw power from a source external to the monitor recorder 14 keeps power considerations independent of the monitor recorder 14. This approach also enables a battery of higher capacity to be introduced when needed to support the additional sensors or components without effecting the monitor recorders circuitry 60.

[0076] Second, the pair of ECG electrodes 38, 39 respectively provided on the distal and proximal ends of the flexible circuit 32 are electrically coupled to the set of pads 34 provided on the bottom of the non-conductive receptacle 25 by way of their respective circuit traces 33, 37. The signal ECG electrode 39 includes a protection circuit 72, which is an inline resistor that protects the patient from excessive leakage current should the front end circuit fail.

[0077] Last, in a further embodiment, the circuitry 70 of the electrode patch 15 includes a cryptographic circuit 73 to authenticate an electrode patch 15 for use with a monitor recorder 14. The cryptographic circuit 73 includes a device capable of secure authentication and validation. The cryptographic device 73 ensures that only genuine, non-expired, safe, and authenticated electrode patches 15 are permitted to provide monitoring data to a monitor recorder 14 and for a specific patient.

[0078] The ECG front end circuit 63 measures raw cutaneous electrical signals using a driven reference that effectively reduces common mode noise, power supply noise and system noise, which is critical to preserving the characteristics of low amplitude cardiac action potentials, especially those signals from the atria. FIG. 11 is a schematic diagram 80 showing the ECG front end circuit 63 of the circuitry 60 of the monitor recorder 14 of FIG. 9. The ECG front end circuit 63 senses body surface potentials through a signal lead (“S1”) and reference lead (“REF”) that are respectively connected to the ECG electrodes of the electrode patch 15. Power is provided to the ECG front end circuit 63 through a pair of DC power leads (“VCC” and “GND”). An analog ECG signal (“ECG”) representative of the electrical activity

of the patient’s heart over time is output, which the micro controller 11 converts to digital representation and filters, as further described infra.

[0079] The ECG front end circuit 63 is organized into five stages, a passive input filter stage 81, a unity gain voltage follower stage 82, a passive high pass filtering stage 83, a voltage amplification and active filtering stage 84, and an anti-aliasing passive filter stage 85, plus a reference generator. Each of these stages and the reference generator will now be described.

[0080] The passive input filter stage 81 includes the parasitic impedance of the ECG electrodes 38, 39 (shown in FIG. 8), the protection resistor that is included as part of the protection circuit 72 of the ECG electrode 39 (shown in FIG. 10), an AC coupling capacitor 87, a termination resistor 88, and filter capacitor 89. This stage passively shifts the frequency response poles downward there is a high electrode impedance from the patient on the signal lead S1 and reference lead REF, which reduces high frequency noise.

[0081] The unity gain voltage follower stage 82 provides a unity voltage gain that allows current amplification by an Operational Amplifier (“Op Amp”) 90. In this stage, the voltage stays the same as the input, but more current is available to feed additional stages. This configuration allows a very high input impedance, so as not to disrupt the body surface potentials or the filtering effect of the previous stage.

[0082] The passive high pass filtering stage 83 is a high pass filter that removes baseline wander and any offset generated from the previous stage. Adding an AC coupling capacitor 91 after the Op Amp 90 allows the use of lower cost components, while increasing signal fidelity.

[0083] The voltage amplification and active filtering stage 84 amplifies the voltage of the input signal through Op Amp 91, while applying a low pass filter. The DC bias of the input signal is automatically centered in the highest performance input region of the Op Amp 91 because of the AC coupling capacitor 91.

[0084] The anti-aliasing passive filter stage 85 provides an anti-aliasing low pass filter. When the microcontroller 61 acquires a sample of the analog input signal, a disruption in the signal occurs as a sample and hold capacitor that is internal to the microcontroller 61 is charged to supply signal for acquisition.

[0085] The reference generator in subcircuit 86 drives a driven reference containing power supply noise and system noise to the reference lead REF. A coupling capacitor 87 is included on the signal lead S1 and a pair of resistors 93a, 93b inject system noise into the reference lead REF. The reference generator is connected directly to the patient, thereby avoiding the thermal noise of the protection resistor that is included as part of the protection circuit 72.

[0086] In contrast, conventional ECG lead configurations try to balance signal and reference lead connections. The conventional approach suffers from the introduction of differential thermal noise, lower input common mode rejection, increased power supply noise, increased system noise, and differential voltages between the patient reference and the reference used on the device that can obscure, at times, extremely, low amplitude body surface potentials.

[0087] Here, the parasitic impedance of the ECG electrodes 38, 39, the protection resistor that is included as part of the protection circuit 72 and the coupling capacitor 87 allow the reference lead REF to be connected directly to the skin’s surface without any further components. As a result,

the differential thermal noise problem caused by pairing protection resistors to signal and reference leads, as used in conventional approaches, is avoided.

[0088] The monitor recorder **14** continuously monitors the patient's heart rate and physiology. FIG. **12** is a flow diagram showing a monitor recorder-implemented method **100** for monitoring ECG data for use in the monitor recorder **14** of FIG. **4**. Initially, upon being connected to the set of pads **34** provided with the non-conductive receptacle **25** when the monitor recorder **14** is snapped into place, the microcontroller **61** executes a power up sequence (step **101**). During the power up sequence, the voltage of the battery **71** is checked, the state of the flash memory **62** is confirmed, both in terms of operability check and available capacity, and microcontroller operation is diagnostically confirmed. In a further embodiment, an authentication procedure between the microcontroller **61** and the electrode patch **15** are also performed.

[0089] Following satisfactory completion of the power up sequence, an iterative processing loop (steps **102-110**) is continually executed by the microcontroller **61**. During each iteration (step **102**) of the processing loop, the ECG frontend **63** (shown in FIG. **9**) continually senses the cutaneous ECG electrical signals (step **103**) via the ECG electrodes **38, 29** and is optimized to maintain the integrity of the P-wave. A sample of the ECG signal is read (step **104**) by the microcontroller **61** by sampling the analog ECG signal that is output by the ECG front end circuit **63**. FIG. **13** is a graph showing, by way of example, a typical ECG waveform **120**. The x-axis represents time in approximate units of tenths of a second. The y-axis represents cutaneous electrical signal strength in approximate units of millivolts. The P-wave **121** has a smooth, normally upward, that is, positive, waveform that indicates atrial depolarization. The QRS complex often begins with the downward deflection of a Q-wave **122**, followed by a larger upward deflection of an R-wave **123**, and terminated with a downward waveform of the S-wave **124**, collectively representative of ventricular depolarization. The T-wave **125** is normally a modest upward waveform, representative of ventricular depolarization, while the U-wave **126**, often not directly observable, indicates the recovery period of the Purkinje conduction fibers.

[0090] Sampling of the R-to-R interval enables heart rate information derivation. For instance, the R-to-R interval represents the ventricular rate and rhythm, while the P-to-P interval represents the atrial rate and rhythm. Importantly, the PR interval is indicative of atrioventricular (AV) conduction time and abnormalities in the PR interval can reveal underlying heart disorders, thus representing another reason why the P-wave quality achievable by the ambulatory electrocardiography monitoring patch optimized for capturing low amplitude cardiac action potential propagation described herein is medically unique and important. The long-term observation of these ECG indicia, as provided through extended wear of the wearable monitor **12**, provides valuable insights to the patient's cardiac function symptoms, and overall well-being.

[0091] Referring back to FIG. **12**, each sampled ECG signal, in quantized and digitized form, is processed by signal processing modules as specified in firmware (step **105**), as described infra, and temporarily staged in a buffer (step **106**), pending compression preparatory to storage in the flash memory **62** (step **107**). Following compression, the compressed ECG digitized sample is again buffered (step

108), then written to the flash memory **62** (step **109**) using the communications bus. Processing continues (step **110**), so long as the monitoring recorder **14** remains connected to the electrode patch **15** (and storage space remains available in the flash memory **62**), after which the processing loop is exited (step **110**) and execution terminates. Still other operations and steps are possible.

[0092] The microcontroller **61** operates under modular micro program control as specified in firmware, and the program control includes processing of the analog ECG signal output by the ECG front end circuit **63**. FIG. **14** is a functional block diagram showing the signal processing functionality **130** of the microcontroller **61**. The microcontroller **61** operates under modular micro program control as specified in firmware **132**. The firmware modules **132** include high and low pass filtering **133**, and compression **134**. Other modules are possible. The microcontroller **61** has a built-in ADC, although ADC functionality could also be provided in the firmware **132**.

[0093] The ECG front end circuit **63** first outputs an analog ECG signal, which the ADC **131** acquires, samples and converts into an uncompressed digital representation. The microcontroller **61** includes one or more firmware modules **133** that perform filtering. In one embodiment, three low pass filters and two high pass filters are used. Following filtering, the digital representation of the cardiac activation wave front amplitudes are compressed by a compression module **134** before being written out to storage **135**.

[0094] The download station executes a communications or offload program ("Offload") or similar program that interacts with the monitor recorder **14** via the external connector **65** to retrieve the stored ECG monitoring data. FIG. **15** is a functional block diagram showing the operations **140** performed by the download station. The download station could be a server, personal computer, tablet or handheld computer, smart mobile device, or purpose-built programmer designed specific to the task of interfacing with a monitor recorder **14**. Still other forms of download station are possible, including download stations connected through wireless interfacing using, for instance, a smart phone connected to the monitor recorder **14** through Bluetooth or Wi-Fi.

[0095] The download station is responsible for offloading stored ECG monitoring data from a monitor recorder **14** and includes an electro mechanical docking interface by which the monitor recorder **14** is connected at the external connector **65**. The download station operates under program-mable control as specified in software **141**. The stored ECG monitoring data retrieved from storage **142** on a monitor recorder **14** is first decompressed by a decompression module **143**, which converts the stored ECG monitoring data back into an uncompressed digital representation more suited to signal processing than a compressed signal. The retrieved ECG monitoring data may be stored into local storage for archival purposes, either in original compressed form, or as uncompressed.

[0096] The download station can include an array of filtering modules. For instance, a set of phase distortion filtering tools **144** may be provided, where corresponding software filters can be provided for each filter implemented in the firmware executed by the microcontroller **61**. The digital signals are run through the software filters in a reverse direction to remove phase distortion. For instance, a 45 Hertz high pass filter in firmware may have a matching

reverse 45 Hertz high pass filter in software. Most of the phase distortion is corrected, that is, canceled to eliminate noise at the set frequency, but data at other frequencies in the waveform remain unaltered. As well, bidirectional impulse infinite response (IIR) high pass filters and reverse direction (symmetric) IIR low pass filters can be provided. Data is run through these filters first in a forward direction, then in a reverse direction, which generates a square of the response and cancels out any phase distortion. This type of signal processing is particularly helpful with improving the display of the ST-segment by removing low frequency noise.

[0097] An automatic gain control (AGC) module **145** can also be provided to adjust the digital signals to a usable level based on peak or average signal level or other metric. AGC is particularly critical to single-lead ECG monitors, where physical factors, such as the tilt of the heart, can affect the electrical field generated. On three-lead Holter monitors, the leads are oriented in vertical, horizontal and diagonal directions. As a result, the horizontal and diagonal leads may be higher amplitude and ECG interpretation will be based on one or both of the higher amplitude leads. In contrast, the electrocardiography monitor **12** has only a single lead that is oriented in the vertical direction, so variations in amplitude will be wider than available with multi-lead monitors, which have alternate leads to fall back upon.

[0098] In addition, AGC may be necessary to maintain compatibility with existing ECG interpretation software, which is typically calibrated for multi-lead ECG monitors for viewing signals over a narrow range of amplitudes. Through the AGC module **145**, the gain of signals recorded by the monitor recorder **14** of the electrocardiography monitor **12** can be attenuated up (or down) to work with FDA-approved commercially available ECG interpretation.

[0099] AGC can be implemented in a fixed fashion that is uniformly applied to all signals in an ECG recording, adjusted as appropriate on a recording-by-recording basis. Typically, a fixed AGC value is calculated based on how an ECG recording is received to preserve the amplitude relationship between the signals. Alternatively, AGC can be varied dynamically throughout an ECG recording, where signals in different segments of an ECG recording are amplified up (or down) by differing amounts of gain.

[0100] Typically, the monitor recorder **14** will record a high resolution, low frequency signal for the P-wave segment. However, for some patients, the result may still be a visually small signal. Although high resolution is present, the unaided eye will normally be unable to discern the P-wave segment. Therefore, gaining the signal is critical to visually depicting P-wave detail. This technique works most efficaciously with a raw signal with low noise and high resolution, as generated by the monitor recorder **14**. Automatic gain control applied to a high noise signal will only exacerbate noise content and be self-defeating.

[0101] Finally, the download station can include filtering modules specifically intended to enhance P-wave content. For instance, a P-wave base boost filter **146**, which is a form of pre-emphasis filter, can be applied to the signal to restore missing frequency content or to correct phase distortion. Still other filters and types of signal processing are possible.

[0102] Conventional ECG monitors, like Holter monitors, invariably require specialized training on proper placement of leads and on the operation of recording apparatuses, plus support equipment purpose-built to retrieve, convert, and store ECG monitoring data. In contrast, the electrocardiography

monitor **12** simplifies monitoring from end to end, starting with placement, then with use, and finally with data retrieval. FIGS. **16A-C** are functional block diagrams respectively showing practical uses **150**, **160**, **170** of the extended wear electrocardiography monitors **12** of FIGS. **1** and **2**. The combination of a flexible extended wear electrode patch and a removable reusable (or single use) monitor recorder empowers physicians and patients alike with the ability to readily perform long-term ambulatory monitoring of the ECG and physiology.

[0103] Especially when compared to existing Holter-type monitors and monitoring patches placed in the upper pectoral region, the electrocardiography monitor **12** offers superior patient comfort, convenience and user-friendliness. To start, the electrode patch **15** is specifically designed for ease of use by a patient (or caregiver); assistance by professional medical personnel is not required. Moreover, the patient is free to replace the electrode patch **15** at any time and need not wait for a doctor's appointment to have a new electrode patch **15** placed. In addition, the monitor recorder **14** operates automatically and the patient only need snap the monitor recorder **14** into place on the electrode patch **15** to initiate ECG monitoring. Thus, the synergistic combination of the electrode patch **15** and monitor recorder **14** makes the use of the electrocardiography monitor **12** a reliable and virtually foolproof way to monitor a patient's ECG and physiology for an extended, or even open-ended, period of time.

[0104] In simplest form, extended wear monitoring can be performed by using the same monitor recorder **14** inserted into a succession of fresh new electrode patches **15**. As needed, the electrode patch **15** can be replaced by the patient (or caregiver) with a fresh new electrode patch **15** throughout the overall monitoring period. Referring first to FIG. **16A**, at the outset of monitoring, a patient adheres a new electrode patch **15** in a location at the sternal midline **16** (or immediately to either side of the sternum **13**) oriented top-to-bottom (step **151**). The placement of the wearable monitor in a location at the sternal midline (or immediately to either side of the sternum), with its unique narrow "hourglass"-like shape, significantly improves the ability of the wearable monitor to cutaneously sense cardiac electrical potential signals, particularly the P-wave (or atrial activity) and, to a lesser extent, the QRS interval signals indicating ventricular activity in the ECG waveforms.

[0105] Placement involves simply adhering the electrode patch **15** on the skin along the sternal midline **16** (or immediately to either side of the sternum **13**). Patients can easily be taught to find the physical landmarks on the body necessary for proper placement of the electrode patch **15**. The physical landmarks are locations on the surface of the body that are already familiar to patients, including the inter-mammary cleft between the breasts above the manubrium (particularly easily locatable by women and gynecomatic men), the sternal notch immediately above the manubrium, and the Xiphoid process located at the bottom of the sternum. Empowering patients with the knowledge to place the electrode patch **15** in the right place ensures that the ECG electrodes will be correctly positioned on the skin, no matter the number of times that the electrode patch **15** is replaced.

[0106] A monitor recorder **14** is snapped into the non-conductive receptacle **25** on the outward-facing surface of the electrode patch **15** (step **152**). The monitor recorder **14** draws power externally from a battery provided in the non-conductive receptacle **25**. In addition, the battery is

replaced each time that a fresh new electrode patch **15** is placed on the skin, which ensures that the monitor recorder **14** is always operating with a fresh power supply and minimizing the chances of a loss of monitoring continuity due to a depleted battery source.

[0107] By default, the monitor recorder **14** automatically initiates monitoring upon sensing body surface potentials through the pair of ECG electrodes (step **153**). In a further embodiment, the monitor recorder **14** can be configured for manual operation, such as by using the tactile feedback button **66** on the outside of the sealed housing **50**, or other user-operable control. In an even further embodiment, the monitor recorder **14** can be configured for remotely-controlled operation by equipping the monitor recorder **14** with a wireless transceiver, such as described in commonly-assigned U.S. Pat. No. 9,433,367, issued Sep. 6, 2016, the disclosure of which is incorporated by reference. The wireless transceiver allows wearable or mobile communications devices to wirelessly interface with the monitor recorder **14**.

[0108] A key feature of the extended wear electrocardiography monitor **12** is the ability to monitor ECG and physiological data for an extended period of time, which can be well in excess of the 14 days currently pitched as being achievable by conventional ECG monitoring approaches. In a further embodiment, ECG monitoring can even be performed over an open-ended time period, as further explained infra. The monitor recorder **14** is reusable and, if so desired, can be transferred to successive electrode patches **15** to ensure continuity of monitoring. At any point during ECG monitoring, a patient (or caregiver) can remove the monitor recorder **14** (step **154**) and replace the electrode patch **15** currently being worn with a fresh new electrode patch **15** (step **151**). The electrode patch **15** may need to be replaced for any number of reasons. For instance, the electrode patch **15** may be starting to come off after a period of wear or the patient may have skin that is susceptible to itching or irritation. The wearing of ECG electrodes can aggravate such skin conditions. Thus, a patient may want or need to periodically remove or replace ECG electrodes during a long-term ECG monitoring period, whether to replace a dislodged electrode, reestablish better adhesion, alleviate itching or irritation, allow for cleansing of the skin, allow for showering and exercise, or for other purpose.

[0109] Following replacement, the monitor recorder **14** is again snapped into the electrode patch **15** (step **152**) and monitoring resumes (step **153**). The ability to transfer the same monitor recorder **14** to successive electrode patches **15** during a period of extended wear monitoring is advantageous not to just diagnose cardiac rhythm disorders and other physiological events of potential concern, but to do extremely long term monitoring, such as following up on cardiac surgery, ablation procedures, or medical device implantation. In these cases, several weeks of monitoring or more may be needed. In addition, some IMDs, such as pacemakers or implantable cardioverter defibrillators, incorporate a loop recorder that will capture cardiac events over a fixed time window. If the telemetry recorded by the IMD is not downloaded in time, cardiac events that occurred at a time preceding the fixed time window will be overwritten by the IMD and therefore lost. The monitor recorder **14** provides continuity of monitoring that acts to prevent loss of cardiac event data. In a further embodiment, the firmware executed by the microcontroller **61** of the monitor recorder **14** can be optimized for minimal power consumption and

additional flash memory for storing monitoring data can be added to achieve a multi-week monitor recorder **14** that can be snapped into a fresh new electrode patch **15** every seven days, or other interval, for weeks or even months on end.

[0110] Upon the conclusion of monitoring, the monitor recorder **14** is removed (step **154**) and recorded ECG and physiological telemetry are downloaded (step **155**). For instance, a download station can be physically interfaced to the external connector **65** of the monitor recorder **14** to initiate and conduct downloading, as described supra with reference to FIG. **15**.

[0111] In a further embodiment, the monitoring period can be of indeterminate duration. Referring next to FIG. **16B**, a similar series of operations are followed with respect to replacement of electrode patches **15**, reinsertion of the same monitor recorder **14**, and eventual download of ECG and physiological telemetry (steps **161-165**), as described supra with reference to FIG. **16A**. However, the flash memory **62** (shown in FIG. **9**) in the circuitry **60** of the monitor recorder **14** has a finite capacity. Following successful downloading of stored data, the flash memory **62** can be cleared to restore storage capacity and monitoring can resume once more, either by first adhering a new electrode patch **15** (step **161**) or by snapping the monitor recorder **14** into an already-adhered electrode patch **15** (step **162**). The foregoing expanded series of operations, to include reuse of the same monitor recorder **14** following data download, allows monitoring to continue indefinitely and without the kinds of interruptions that often affect conventional approaches, including the retrieval of monitoring data only by first making an appointment with a medical professional.

[0112] In a still further embodiment, when the monitor recorder **14** is equipped with a wireless transceiver, the use of a download station can be skipped. Referring last to FIG. **16C**, a similar series of operations are followed with respect to replacement of electrode patches **15** and reinsertion of the same monitor recorder **14** (steps **171-174**), as described supra with reference to FIG. **16A**. However, recorded ECG and physiological telemetry are downloaded wirelessly (step **175**), such as described in commonly-assigned U.S. Pat. No. 9,433,367, cited supra. The recorded ECG and physiological telemetry can even be downloaded wirelessly directly from a monitor recorder **14** during monitoring while still snapped into the non-conductive receptacle **25** on the electrode patch **15**. The wireless interfacing enables monitoring to continue for an open-ended period of time, as the downloading of the recorded ECG and physiological telemetry will continually free up onboard storage space. Further, wireless interfacing simplifies patient use, as the patient (or caregiver) only need worry about placing (and replacing) electrode patches **15** and inserting the monitor recorder **14**. Still other forms of practical use of the extended wear electrocardiography monitors **12** are possible.

[0113] The circuit trace and ECG electrodes components of the electrode patch **15** can be structurally simplified. In a still further embodiment, the flexible circuit **32** (shown in FIG. **5**) and distal ECG electrode **38** and proximal ECG electrode **39** (shown in FIG. **6**) are replaced with a pair of interlaced flexile wires. The interlacing of flexile wires through the flexible backing **20** reduces both manufacturing costs and environmental impact, as further described infra. The flexible circuit and ECG electrodes are replaced with a pair of flexile wires that serve as both electrode circuit traces and electrode signal pickups. FIG. **17** is a perspective view

180 of an extended wear electrode patch **15** with a flexile wire electrode assembly in accordance with a still further embodiment. The flexible backing **20** maintains the unique narrow “hourglass”-like shape that aids long term extended wear, particularly in women, as described supra with reference to FIG. 4. For clarity, the non-conductive receptacle **25** is omitted to show the exposed battery printed circuit board **182** that is adhered underneath the non-conductive receptacle **25** to the proximal end **31** of the flexible backing **20**. Instead of employing flexible circuits, a pair of flexile wires are separately interlaced or sewn into the flexible backing **20** to serve as circuit connections for an anode electrode lead and for a cathode electrode lead.

[0114] To form a distal electrode assembly, a distal wire **181** is interlaced into the distal end **30** of the flexible backing **20**, continues along an axial path through the narrow longitudinal midsection of the elongated strip, and electrically connects to the battery printed circuit board **182** on the proximal end **31** of the flexible backing **20**. The distal wire **181** is connected to the battery printed circuit board **182** by stripping the distal wire **181** of insulation, if applicable, and interlacing or sewing the uninsulated end of the distal wire **181** directly into an exposed circuit trace **183**. The distal wire-to-battery printed circuit board connection can be made, for instance, by back stitching the distal wire **181** back and forth across the edge of the battery printed circuit board **182**. Similarly, to form a proximal electrode assembly, a proximal wire (not shown) is interlaced into the proximal end **31** of the flexible backing **20**. The proximal wire is connected to the battery printed circuit board **182** by stripping the proximal wire of insulation, if applicable, and interlacing or sewing the uninsulated end of the proximal wire directly into an exposed circuit trace **184**. The resulting flexile wire connections both establish electrical connections and help to affix the battery printed circuit board **182** to the flexible backing **20**.

[0115] The battery printed circuit board **182** is provided with a battery compartment **36**. A set of electrical pads **34** are formed on the battery printed circuit board **182**. The electrical pads **34** electrically interface the battery printed circuit board **182** with a monitor recorder **14** when fitted into the non-conductive receptacle **25**. The battery compartment **36** contains a spring **185** and a clasp **186**, or similar assembly, to hold a battery (not shown) in place and electrically interfaces the battery to the electrical pads **34** through a pair battery leads **187** for powering the electrocardiography monitor **14**. Other types of battery compartment are possible. The battery contained within the battery compartment **36** can be replaceable, rechargeable, or disposable.

[0116] In a yet further embodiment, the circuit board and non-conductive receptacle **25** are replaced by a combined housing that includes a battery compartment and a plurality of electrical pads. The housing can be affixed to the proximal end of the elongated strip through the interlacing or sewing of the flexile wires or other wires or threads.

[0117] The core of the flexile wires may be made from a solid, stranded, or braided conductive metal or metal compounds. In general, a solid wire will be less flexible than a stranded wire with the same total cross-sectional area, but will provide more mechanical rigidity than the stranded wire. The conductive core may be copper, aluminum, silver, or other material. The pair of the flexile wires may be provided as insulated wire. In one embodiment, the flexile wires are made from a magnet wire from Belden Cable,

catalogue number **8051**, with a solid core of AWG **22** with bare copper as conductor material and insulated by polyurethane or nylon. Still other types of flexile wires are possible. In a further embodiment, conductive ink or graphene can be used to print electrical connections, either in combination with or in place of the flexile wires.

[0118] In a still further embodiment, the flexile wires are uninsulated. FIG. **18** is perspective view of the flexile wire electrode assembly from FIG. **17**, with a layer of insulating material **189** shielding a bare uninsulated distal wire **181** around the midsection on the contact side of the flexible backing. On the contact side of the proximal and distal ends of the flexible backing, only the portions of the flexile wires serving as electrode signal pickups are electrically exposed and the rest of the flexile wire on the contact side outside of the proximal and distal ends are shielded from electrical contact. The bare uninsulated distal wire **181** may be insulated using a layer of plastic, rubber-like polymers, or varnish, or by an additional layer of gauze or adhesive (or non-adhesive) gel. The bare uninsulated wire **181** on the non-contact side of the flexible backing may be insulated or can simply be left uninsulated.

[0119] Both end portions of the pair of flexile wires are typically placed uninsulated on the contact surface of the flexible backing **20** to form a pair of electrode signal pickups. FIG. **19** is a bottom view **190** of the flexile wire electrode assembly as shown in FIG. **17**. When adhered to the skin during use, the uninsulated end portions of the distal wire **181** and the proximal wire **191** enable the monitor recorder **14** to measure dermal electrical potential differentials. At the proximal and distal ends of the flexible backing **20**, the uninsulated end portions of the flexile wires may be configured into an appropriate pattern to provide an electrode signal pickup, which would typically be a spiral shape formed by guiding the flexile wire along an inwardly spiraling pattern. The surface area of the electrode pickups can also be variable, such as by selectively removing some or all of the insulation on the contact surface. For example, an electrode signal pickup arranged by sewing insulated flexile wire in a spiral pattern could have a crescent-shaped cutout of uninsulated flexile wire facing towards the signal source.

[0120] In a still yet further embodiment, the flexile wires are left freely riding on the contact surfaces on the distal and proximal ends of the flexible backing, rather than being interlaced into the ends of the flexible backing **20**. FIG. **20** is a bottom view **200** of a flexile wire electrode assembly in accordance with a still yet further embodiment. The distal wire **181** is interlaced onto the midsection and extends an exposed end portion **192** onto the distal end **30**. The proximal wire **191** extends an exposed end portion **193** onto the proximal end **31**. The exposed end portions **192** and **193**, not shielded with insulation, are further embedded within an electrically conductive adhesive **201**. The adhesive **201** makes contact to skin during use and conducts skin electrical potentials to the monitor recorder **14** (not shown) via the flexile wires. The adhesive **201** can be formed from electrically conductive, non-irritating adhesive, such as hydrocolloid.

[0121] The distal wire **181** is interlaced or sewn through the longitudinal midsection of the flexible backing **20** and takes the place of the flexible circuit **32**. FIG. **21** is a perspective view showing the longitudinal midsection of the flexible backing of the electrode assembly from FIG. **17**. Various stitching patterns may be adopted to provide a

proper combination of rigidity and flexibility. In simplest form, the distal wire **181** can be manually threaded through a plurality of holes provided at regularly-spaced intervals along an axial path defined between the battery printed circuit board **182** (not shown) and the distal end **30** of the flexible backing **20**. The distal wire **181** can be threaded through the plurality of holes by stitching the flexible wire as a single “thread.” Other types of stitching patterns or stitching of multiple “threads” could also be used, as well as using a sewing machine or similar device to machine-stitch the distal wire **181** into place, as further described infra. Further, the path of the distal wire **181** need not be limited to a straight line from the distal to the proximal end of the flexible backing **20**.

[0122] While the invention has been particularly shown and described as referenced to the embodiments thereof, those skilled in the art will understand that the foregoing and other changes in form and detail may be made therein without departing from the spirit and scope.

What is claimed is:

1. An extended wear electrocardiography patch with wire electrode assemblies, comprising:

a flexible backing;

a battery printed circuit board affixed on a proximal end of the flexible backing;

a distal electrode assembly comprising a distal wire, a portion of which is affixed to a distal end of the flexible backing and configured in a pattern and a further portion of the distal wire interlaced along the flexible backing and connected to the battery printed circuit board; and

a proximal electrode assembly comprising a proximal wire configured in a pattern on the proximal end of the flexible backing and connected to the battery printed circuit board.

2. An extended wear electrocardiography patch in accordance with claim 1, wherein the portion of the distal wire configured in the pattern on the distal end of the flexible backing and the proximal wire configured in the pattern on the proximal end of the flexible backing are insulated or uninsulated.

3. An extended wear electrocardiography patch in accordance with claim 1, the portion of the distal wire configured in the pattern on the distal end of the flexible backing and the proximal wire configured in the pattern on the proximal end of the flexible backing are one of stitched into the flexible backing and free riding on a surface of the flexible backing.

4. An extended wear electrocardiography patch in accordance with claim 1, wherein the battery printed circuit board comprises a set of electrical pads configured to electrically interface with an electrocardiography monitor recorder to collect electrical potential differentials.

5. An extended wear electrocardiography patch in accordance with claim 4, further comprising:

a pair of battery leads configured to interface at least a portion of the electrical pads to a battery to power the electrocardiography monitor recorder.

6. An extended wear electrocardiography patch in accordance with claim 1, wherein the further portion of the distal wire interlaced along the flexible backing is one of insulated and uninsulated.

7. An extended wear electrocardiography patch in accordance with claim 6, further comprising:

a layer of insulating material covering the further portion of the distal wire interlaced along the flexible backing when the further portion of the distal wire is uninsulated.

8. An extended wear electrocardiography patch in accordance with claim 7, wherein the layer of insulating material comprises one or more of plastic, rubber-like polymers, varnish, gauze, and adhesive gel.

9. An extended wear electrocardiography patch in accordance with claim 1, wherein the proximal and distal wires each comprise a core of one of a solid, stranded, and braided material.

10. An extended wear electrocardiography patch in accordance with claim 9, wherein the material of the proximal and distal wires comprise one or more of metal, copper, aluminum, silver, and a compound of materials.

11. An extended wear electrocardiography monitor with wire electrode assemblies, comprising:

an electrocardiography patch, comprising:

a flexible backing;

a battery printed circuit board affixed on a proximal end of the flexible backing;

a distal electrode assembly comprising a distal wire, a portion of which is affixed to a distal end of the flexible backing and configured in a pattern and a further portion of the distal wire interlaced along the flexible backing and connected to the battery printed circuit board; and

a proximal electrode assembly comprising a proximal wire configured in a pattern on the proximal end of the flexible backing and connected to the battery printed circuit board; and

an electrocardiography monitor recorder, comprising:

a sealed housing shaped to be removably attached to the electrocardiography patch;

an externally-powered micro-controller; and

an electrocardiographic front end circuit interfaced to the micro-controller and operable to sense electrocardiographic signals through the distal and proximal wires.

12. An extended wear electrocardiography monitor in accordance with claim 11, wherein the portion of the distal wire configured in the pattern on the distal end of the flexible backing and the proximal wire configured in the pattern on the proximal end of the flexible backing are insulated or uninsulated.

13. An extended wear electrocardiography monitor in accordance with claim 11, the portion of the distal wire configured in the pattern on the distal end of the flexible backing and the proximal wire configured in the pattern on the proximal end of the flexible backing are one of stitched into the flexible backing and free riding on a surface of the flexible backing.

14. An extended wear electrocardiography monitor in accordance with claim 11, wherein the battery printed circuit board comprises a set of electrical pads configured to electrically interface with the electrocardiography monitor recorder to collect electrocardiographic signals.

15. An extended wear electrocardiography monitor in accordance with claim 14, further comprising:

a pair of battery leads configured to interface at least a portion of the electrical pads to a battery to power the electrocardiography monitor recorder.

16. An extended wear electrocardiography monitor in accordance with claim **11**, wherein the further portion of the distal wire interlaced along the flexible backing is one of insulated and uninsulated.

17. An extended wear electrocardiography monitor in accordance with claim **16**, further comprising:

a layer of insulating material covering the further portion of the distal wire interlaced along the flexible backing when the further portion of the distal wire is uninsulated.

18. An extended wear electrocardiography monitor in accordance with claim **17**, wherein the layer of insulating material comprises one or more of plastic, rubber-like polymers, varnish, gauze, and adhesive gel.

19. An extended wear electrocardiography monitor in accordance with claim **11**, wherein the proximal and distal wires each comprise a core of one of a solid, stranded, and braided material.

20. An extended wear electrocardiography monitor in accordance with claim **19**, wherein the material of the proximal and distal wires comprise one or more of metal, copper, aluminum, silver, and a compound of materials.

* * * * *

专利名称(译)	带线电极组件的延长磨损心电监护仪		
公开(公告)号	US20190246933A1	公开(公告)日	2019-08-15
申请号	US16/389798	申请日	2019-04-19
[标]申请(专利权)人(译)	BARDY诊断		
申请(专利权)人(译)	BARDY诊断, INC.		
当前申请(专利权)人(译)	BARDY诊断, INC.		
[标]发明人	FELIX JASON BISHAY JON MIKALSON BARDY GUST H		
发明人	FELIX, JASON BISHAY, JON MIKALSON BARDY, GUST H.		
IPC分类号	A61B5/0408 A61B5/00 A61B5/044 A61B5/0428 A61B5/04		
CPC分类号	A61B5/04087 A61B5/0006 A61B5/04085 A61B5/044 A61B5/6823 A61B5/0428 A61B5/04017 A61B5/6832 A61B2560/0412 A61B2560/0456 A61B5/04325		
优先权	61/882403 2013-09-25 US		
外部链接	Espacenet USPTO		

摘要(译)

可以通过轻便的可穿戴监视器提供生理监测，该监视器包括两个部件，带有缝合电极的柔性延长耐磨电极贴片和可重复使用的监视器记录器，可拆卸地卡入电极贴片上的插座。监护仪位于患者胸部的中央，沿着胸骨从上到下。将可穿戴式监视器放置在胸骨中线的位置，具有独特的“沙漏”形状，显着提高了可穿戴式监视器能够快速感知心电信号的能力，特别是P波和QRS间隔信号指示ECG波形中的心室活动。特别地，电极贴片上的ECG电极被定制成沿着胸骨的中线轴向定位，用于捕获动作电位传播，其取向对应于用于感测阳性的常规12导联ECG中使用的aVF导联。或直立的P波。

