



US 20190022397A1

(19) **United States**

(12) **Patent Application Publication**  
**Srivastava et al.**

(10) **Pub. No.: US 2019/0022397 A1**

(43) **Pub. Date: Jan. 24, 2019**

(54) **SENSOR-BASED PAIN MANAGEMENT SYSTEMS AND METHODS**

*A61B 5/053* (2006.01)

*A61B 5/02* (2006.01)

*A61B 5/024* (2006.01)

(71) Applicant: **Boston Scientific Neuromodulation Corporation, Valencia, CA (US)**

(52) **U.S. Cl.**

CPC .. *A61N 1/36139* (2013.01); *A61B 2562/0223*

(2013.01); *A61B 5/1112* (2013.01); *A61B*

*5/1118* (2013.01); *A61B 5/1116* (2013.01);

*A61B 5/1121* (2013.01); *A61B 5/0402*

(2013.01); *A61B 5/0488* (2013.01); *A61B*

*5/0476* (2013.01); *A61B 5/0533* (2013.01);

*A61B 5/02028* (2013.01); *A61B 5/02416*

(2013.01); *A61N 1/36071* (2013.01); *A61B*

*2562/0219* (2013.01); *A61B 2562/0261*

(2013.01); *A61B 5/4824* (2013.01)

(72) Inventors: **Kyle Harish Srivastava, Saint Paul, MN (US); Pramodsingh Hirasingsh Thakur, Woodbury, MN (US); Dat Thanh Huynh, West Hollywood, CA (US); Bryan Allen Clark, Forest Lake, MN (US); Jianwen Gu, Valencia, CA (US)**

(21) Appl. No.: **16/034,304**

(22) Filed: **Jul. 12, 2018**

(57)

**ABSTRACT**

**Related U.S. Application Data**

(60) Provisional application No. 62/533,789, filed on Jul. 18, 2017.

**Publication Classification**

(51) **Int. Cl.**

*A61N 1/36* (2006.01)

*A61B 5/00* (2006.01)

*A61B 5/11* (2006.01)

*A61B 5/0402* (2006.01)

*A61B 5/0488* (2006.01)

*A61B 5/0476* (2006.01)

This document discusses, among other things, systems and methods for managing pain of a subject. A system includes a first sensor circuit to sense a first signal indicative of a functional state of the subject, a second sensor circuit to sense a second signal different from the first signal, and a controller circuit. The controller circuit may determine an operating mode of the second sensor circuit according to the sensed first signal, trigger the second sensor circuit to sense the second signal under the determined operating mode, and generate a pain score using at least the second signal sensed under the determined operating mode. The pain score may be output to a patient or used for closed-loop control of a pain therapy.

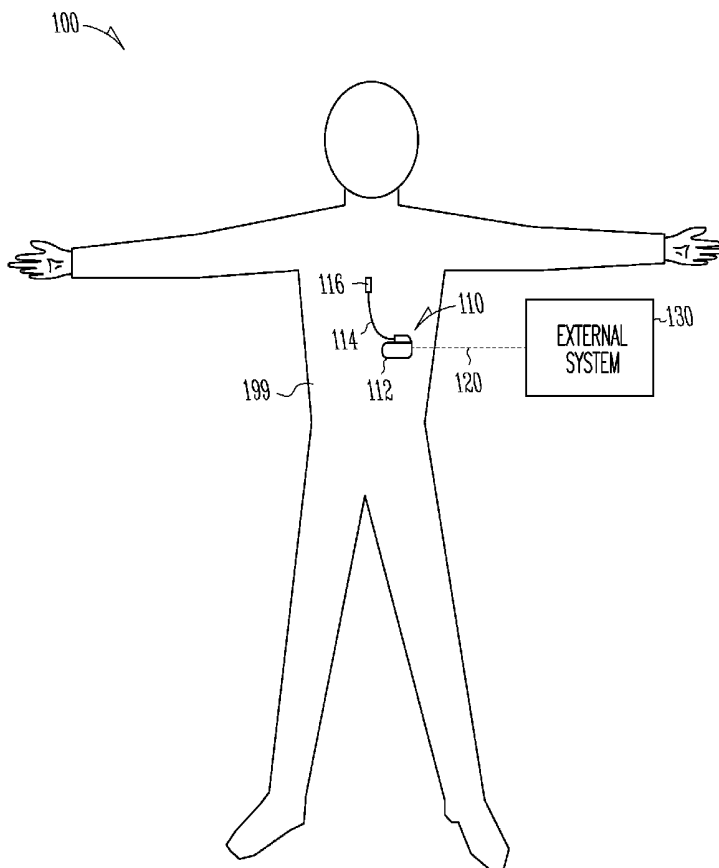

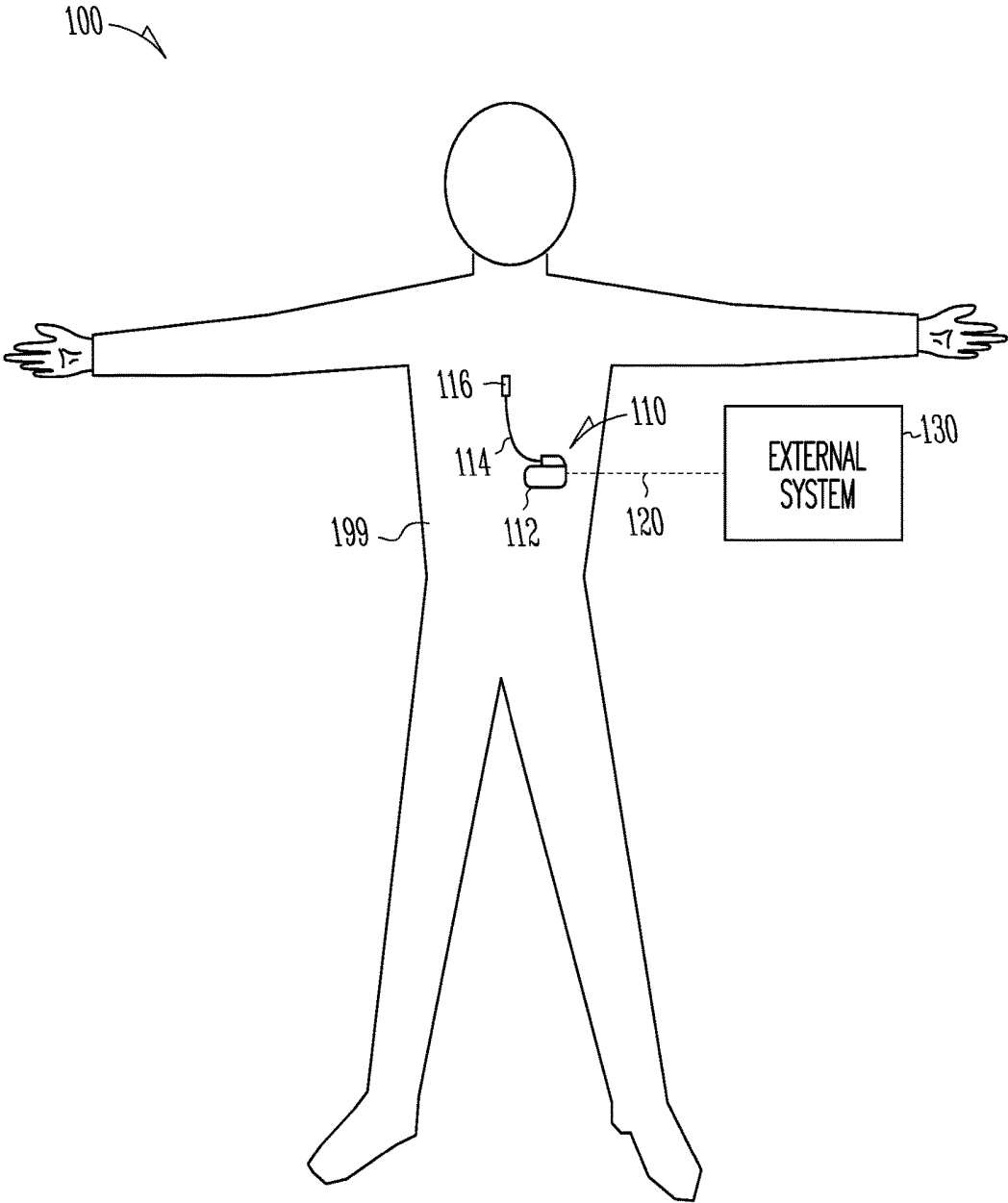

*Fig. 1*

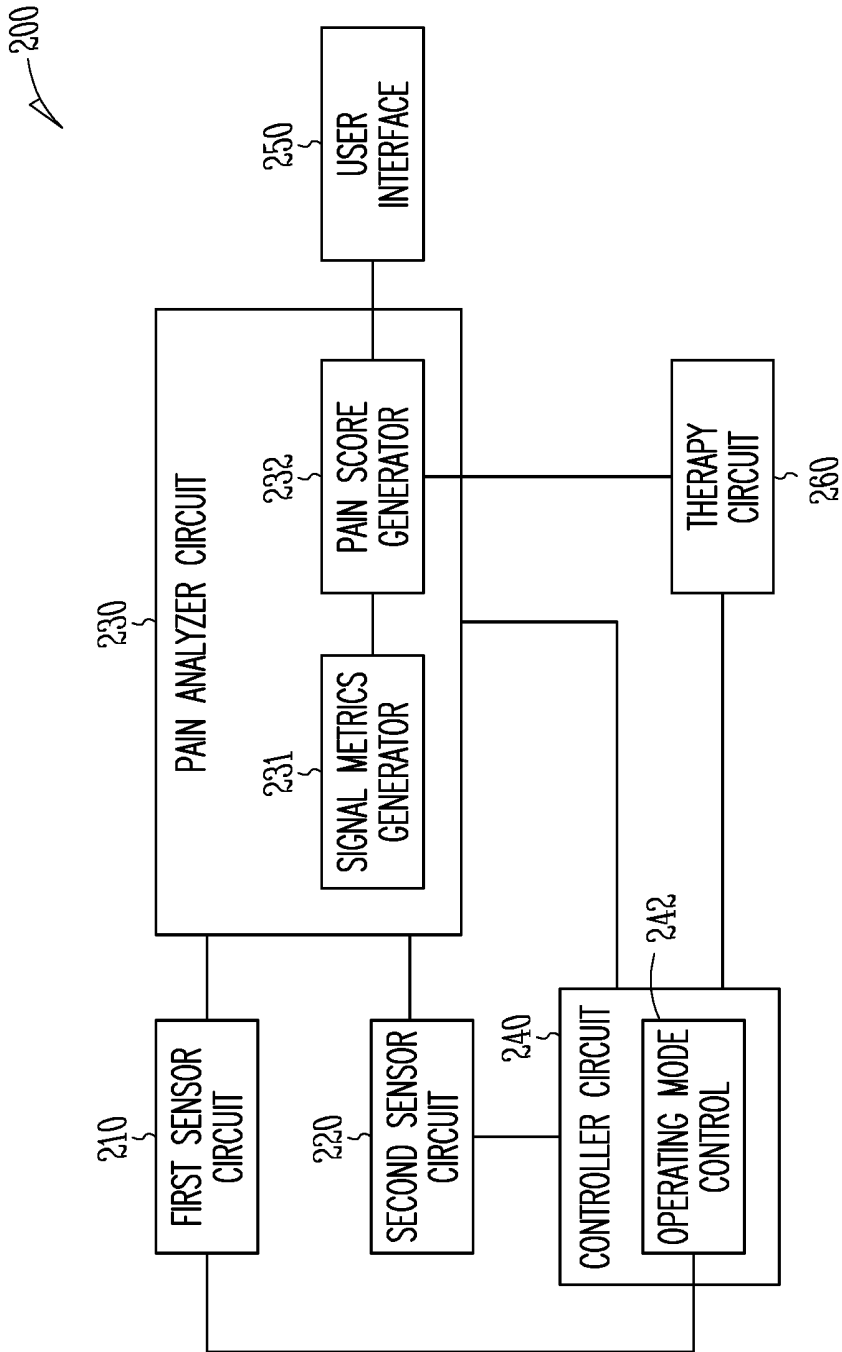

Fig. 2

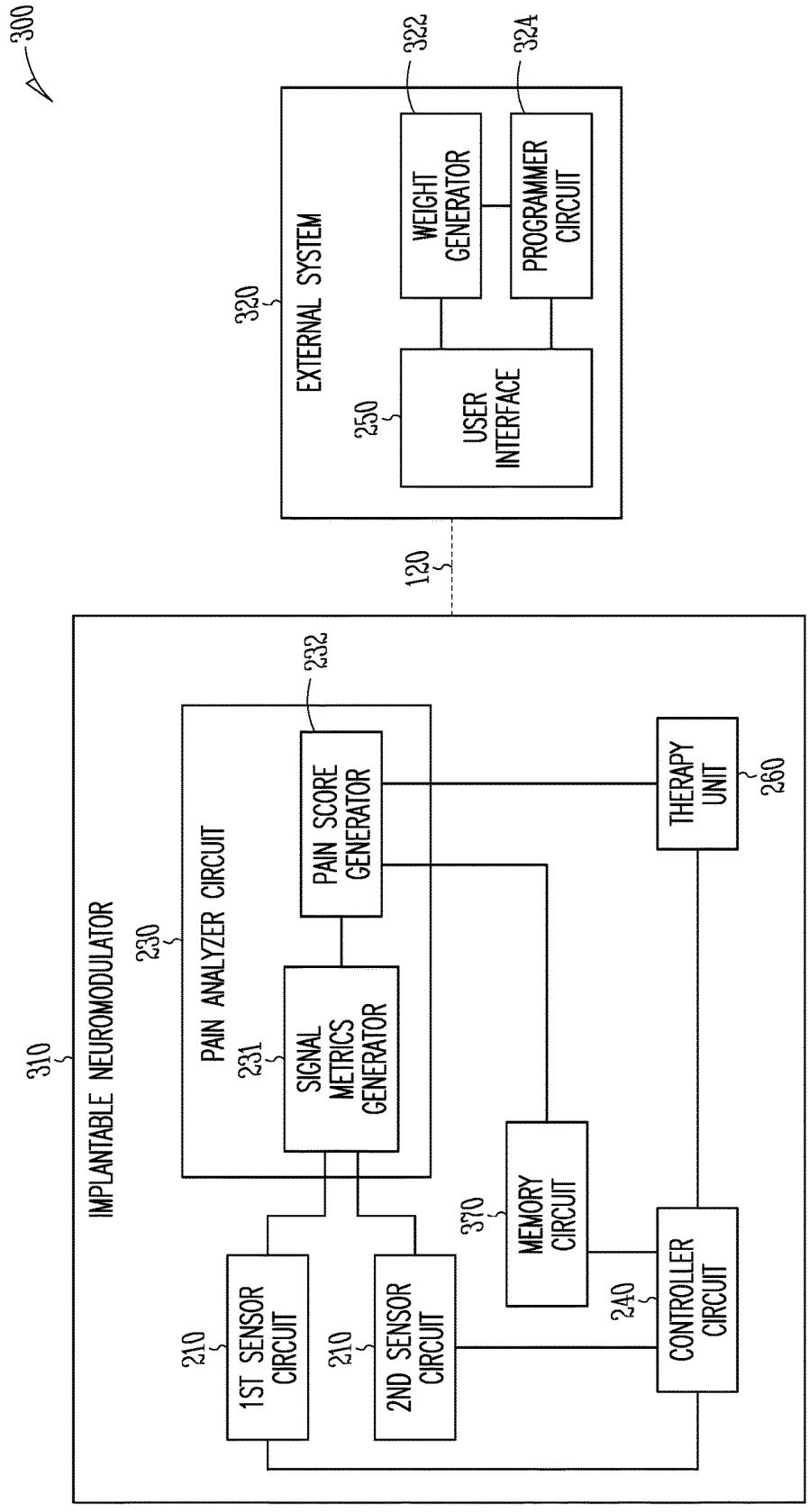

Fig. 3

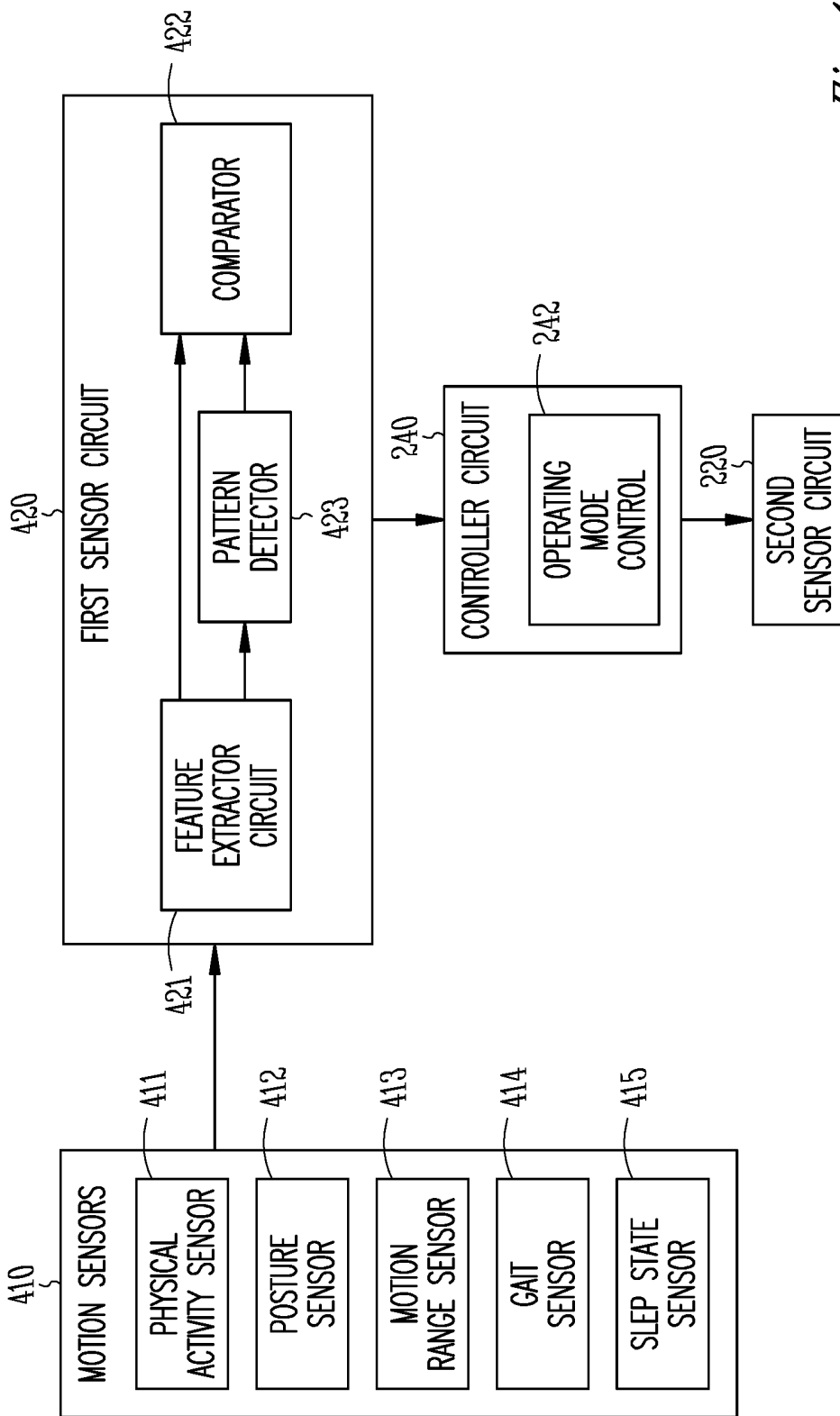
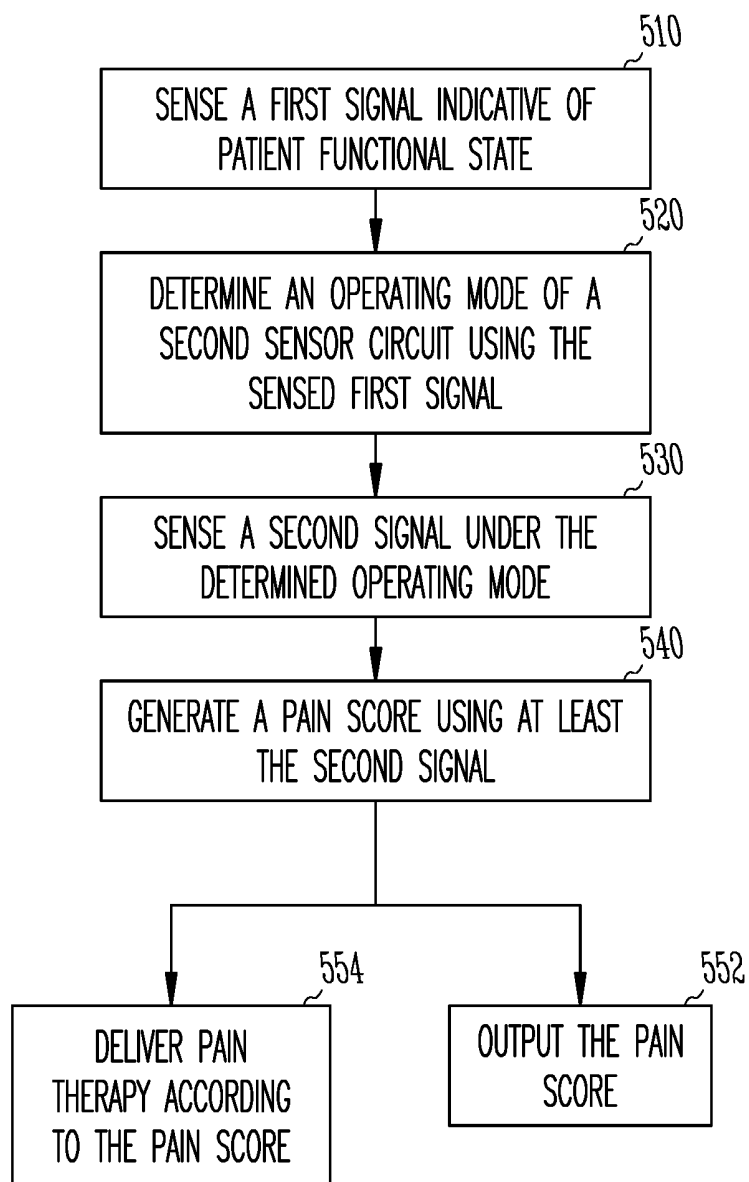

Fig. 4

500 ↗



*Fig. 5*

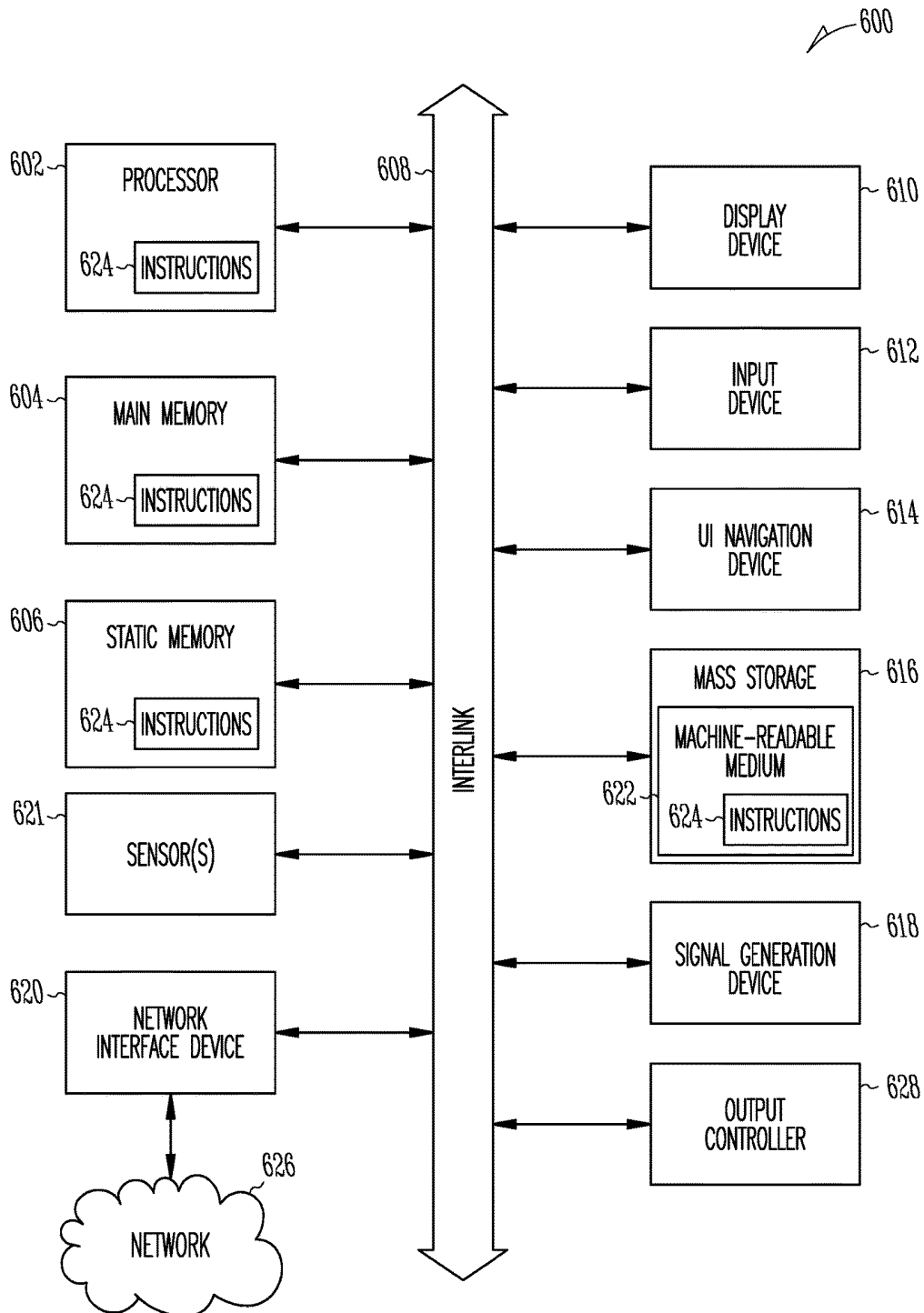

Fig. 6

## SENSOR-BASED PAIN MANAGEMENT SYSTEMS AND METHODS

### CLAIM OF PRIORITY

**[0001]** This application claims the benefit of priority under 35 U.S.C. § 119(e) of U.S. Provisional Patent Application Ser. No. 62/533,789, filed on Jul. 18, 2017, which is herein incorporated by reference in its entirety.

### CROSS REFERENCE TO RELATED APPLICATIONS

**[0002]** This application is related to commonly assigned U.S. Provisional Patent Application Ser. No. 62/445,075, entitled "PAIN MANAGEMENT BASED ON FUNCTIONAL MEASUREMENTS", filed on Jan. 11, 2017, which is incorporated by reference in their entirety.

### TECHNICAL FIELD

**[0003]** This document relates generally to medical systems and more particularly to systems, devices, and methods for pain management.

### BACKGROUND

**[0004]** Pain is one of the most common and among the most personally compelling reasons for seeking medical attention, and consumes considerable healthcare resources each year. The relation between etiology, underlying mechanisms and the specific symptoms and signs related to painful disorders is complex. Pain in an individual patient may be produced by more than one mechanism.

**[0005]** Chronic pain, such as pain present most of the time for a period of six months or longer during the prior year, is a highly pervasive complaint and consistently associated with psychological illness. Chronic pain may originate with a trauma, injury or infection, or there may be an ongoing cause of pain. Chronic pain may also present in the absence of any past injury or evidence of body damage. Common chronic pain can include headache, low back pain, cancer pain, arthritis pain, neurogenic pain (pain resulting from damage to the peripheral nerves or to the central nervous system), or psychogenic pain (pain not due to past disease or injury or any visible sign of damage inside or outside the nervous system).

**[0006]** Chronic pain may be treated or alleviated using medications, acupuncture, surgery, and neuromodulation therapy, among others. Examples of neuromodulation include Spinal Cord Stimulation (SCS), Deep Brain Stimulation (DBS), Peripheral Nerve Stimulation (PNS), and Functional Electrical Stimulation (FES). Implantable neuromodulation systems have been applied to deliver such a therapy. An implantable neuromodulation system may include an implantable neurostimulator, also referred to as an implantable pulse generator (IPG), which can electrically stimulate tissue or nerve centers to treat nervous or muscular disorders. In an example, an IPG can deliver electrical pulses to a specific region in a patient's spinal cord, such as particular spinal nerve roots or nerve bundles, to create an analgesic effect that masks pain sensation.

### SUMMARY

**[0007]** By way of example, chronic pain management may involve determining appropriate treatment regimens such as

SCS and evaluating therapy efficacy. Accurate pain assessment and characterization are desirable for managing patients with chronic pain. Currently, pain assessment generally relies on patient subjective report of pain symptoms, including severity, pattern, or duration of pain. Based on the patient reported pain sensation, a clinician may prescribe a pain therapy, such as to program an electrostimulator for delivering a neuromodulation therapy. However, the subjective description of pain sensation may be constrained by patient cognitive abilities. The subjective pain description may also be subject to intra-patient variation, such as due to a progression of a chronic disease, or a change in general health status or medication. Having a patient to report and describe each pain episode that he or she has experienced is not efficient, and may delay appropriate pain therapy. Additionally, for patients in an ambulatory setting who lacks immediate access to medical assistance, manual adjustment of pain therapy by a clinician may not be feasible especially if immediate therapy titration is required.

**[0008]** Some sensors may sense patient response to pain and detect onset of a pain episode or worsening of pain. Operating these sensors for pain detection and pain assessment, however, may consume a lot of power and require substantial computing resources, particularly when chronic pain monitoring and assessment is desired. In certain implementations, some sensors may be incorporated into an ambulatory monitor for ambulatory and chronic pain monitoring. The ambulatory monitor usually has limited battery power, storage space, information processing power, and communication bandwidth. These constraints may affect the performance of sensor-based ambulatory pain assessment. Additionally, patient pain may be associated with a patient context, such as when a patient engages in physical activities, or during a certain time of a day. Using the patient context may lead to more efficient sensor usage and improved pain monitoring and assessment. The present inventors have recognized that there remains a demand for apparatus and methods of ambulatory monitoring, sensor-based pain assessment, and automated pain therapy.

**[0009]** This document discusses, among other things, systems, devices, and methods for assessing pain of a subject. The system includes a first sensor circuit to sense from the patient a first signal indicative of a functional state of the patient, a second sensor circuit to sense a second signal different from the first signal, and a controller circuit. The second signal may include a physiological signal or a functional signal. The controller circuit may determine an operating mode of the second sensor circuit using the sensed first signal, trigger the second sensor circuit to sense the second signal under the determined operating mode, and generate a pain score using at least the second signal sensed under the determined operating mode. The pain score can be output to a patient or used for closed-loop control of a pain therapy.

**[0010]** Example 1 is a system for managing pain of a patient. The system comprises a first sensor circuit that may sense from the patient a first signal indicative of a functional state of the patient, a second sensor circuit that may sense from the patient a second signal different from the first signal, and a controller circuit. The controller circuit may determine an operating mode of the second sensor circuit using the sensed first signal, trigger the second sensor circuit to sense the second signal under the determined operating mode, and generate a pain score using at least the second

signal sensed under the determined operating mode. The system may output the pain score to a user or a process.

**[0011]** In Example 2, the subject matter of Example 1 optionally includes an electrostimulator coupled to the controller circuit that may generate electrostimulation energy to treat pain. The controller circuit may control the electrostimulator to deliver a pain therapy and to control the electrostimulation energy generated by the electrostimulator according to the pain score.

**[0012]** In Example 3, the subject matter of Example 2 optionally includes the electrostimulator that may deliver at least one of: a spinal cord stimulation; a brain stimulation; or a peripheral nerve stimulation.

**[0013]** In Example 4, the subject matter of any one or more of Examples 1-3 optionally includes the first sensor circuit that may be coupled to at least one ambulatory sensor to sense the first signal. The ambulatory sensor may include at least one of: an accelerometer; a gyroscope; a magnetometer; a strain gauge; or a global positioning system sensor.

**[0014]** In Example 5, the subject matter of any one or more of Examples 1-4 optionally includes the first signal that may include a physical activity signal. The controller circuit may trigger the second sensor circuit to sense the second signal under a first operating mode if the physical activity signal falls below an activity threshold, and trigger the second sensor circuit to sense the second signal under a second operating mode different from the first operating mode if the physical activity signal exceeds the activity threshold.

**[0015]** In Example 6, the subject matter of any one or more of Examples 1-4 optionally includes the first signal that may include a physical activity signal. The controller circuit may trigger the second sensor circuit to sense the second signal under a first operating mode if the physical activity signal corresponds to a physical activity template indicative of a physical activity pattern when the patient is free of pain, and trigger the second sensor circuit to sense the second signal under a second operating mode different from the first operating mode if the physical activity signal fails to correspond to the physical activity template.

**[0016]** In Example 7, the subject matter of any one or more of Examples 1-3 optionally includes the first signal that may include a posture signal.

**[0017]** In Example 8, the subject matter of any one or more of Examples 1-3 optionally includes the first signal that may include a gait or a balance signal.

**[0018]** In Example 9, the subject matter of any one or more of Examples 1-3 optionally includes the first signal that may include a range-of-motion signal.

**[0019]** In Example 10, the subject matter of any one or more of Examples 1-9 optionally includes the second signal that may include at least one of: a cardiac electrical activity signal; an electromyography signal; a photoplethysmography signal; a galvanic skin response signal; an electroencephalogram signal; or a hemodynamic signal.

**[0020]** In Example 11, the subject matter of any one or more of Examples 1-10 optionally includes the controller circuit that may determine the operating mode of the second sensor circuit including initiating data acquisition if the sensed first signal satisfies a condition.

**[0021]** In Example 12, the subject matter of any one or more of Examples 1-11 optionally includes the controller circuit that may determine the operating mode of the second

sensor circuit including adjusting data acquisition rate if the sensed first signal satisfies a condition.

**[0022]** In Example 13, the subject matter of any one or more of Examples 1-12 optionally includes the control circuit that may generate one or more signal metrics from the sensed second signal under the determined operating mode, and generate the pain score using the generated one or more signal metrics respectively weighted by weight factors.

**[0023]** In Example 14, the subject matter of any one or more of Examples 1-13 optionally includes the control circuit that may generate the pain score further using the sensed first signal.

**[0024]** In Example 15, the subject matter of any one or more of Examples 2-14 optionally includes an implantable neuromodulator device that may include one or more of the first sensor circuit, the second sensor circuit, the controller circuit, or the electrostimulator.

**[0025]** Example 16 is a method for managing pain of a patient using an implantable neuromodulator device. The method comprises steps of: sensing a first signal indicative of a functional state of the patient via a first sensor circuit; determining an operating mode of a second sensor circuit using the sensed first signal; sensing a second signal via the second sensor circuit under the determined operating mode, the second signal different from the first signal; generating a pain score using at least the second signal sensed under the determined operating mode; and outputting the pain score to a user or a process.

**[0026]** In Example 17, the subject matter of Example 16 optionally includes delivering a pain therapy via the implantable neuromodulator device. The pain therapy may include electrostimulation energy determined according to the pain score.

**[0027]** In Example 18, the subject matter of Example 16 optionally includes determining the operating mode of the second sensor circuit, which may include initiating data acquisition if the sensed first signal satisfies a condition.

**[0028]** In Example 19, the subject matter of Example 16 optionally includes determining the operating mode of the second sensor circuit, which may include adjusting data acquisition rate if the sensed first signal satisfies a condition.

**[0029]** In Example 20, the subject matter of Example 16 optionally includes the first signal that may include a physical activity signal. The determining the operating mode of the second sensor circuit may include steps of: comparing the sensed physical activity signal to an activity threshold or to an activity template; initiating data acquisition of the second signal or acquiring the second signal at a first data acquisition rate if the comparison satisfies a first condition; and withholding data acquisition of the second signal or acquiring the second signal at a second, lower data acquisition rate than the first data acquisition rate if the comparison satisfies a second condition indicating a higher physical activity level.

**[0030]** In Example 21, the subject matter of Example 16 optionally includes the first signal that may include at least one of a posture signal, a balance signal, or a range-of-motion signal.

**[0031]** In Example 22, the subject matter of Example 16 optionally includes the second signal that may include at least one of a cardiac electrical activity signal, an electromyography signal, a photoplethysmography signal, a galvanic skin response signal, an electroencephalogram signal, or a hemodynamic signal.

**[0032]** In Example 23, the subject matter of Example 16 optionally includes generating one or more signal metrics from the sensed second signal under the determined operating mode. The generating the pain score includes using the generated one or more signal metrics respectively weighted by weight factors.

**[0033]** The pain score generated based on the functional signals, such as based on the motor activity or sleep state signals as discussed in this document, may improve medical diagnostics of automated characterization of patient pain, as well as individualized therapies to alleviate pain and to reduce side effects. The systems, devices, and methods discussed in this document may also enhance the performance and functionality of a pain management system or device. A device or a system programmed with the sensor-based pain assessment methods improves the automaticity in pain assessment. More efficient device memory or communication bandwidth usage may be achieved by storing or transmitting medical information more relevant to clinical decisions.

**[0034]** The systems and methods for pain assessment that use a first sensor signal to trigger data acquisition and storage of a second sensor signal, as discussed in this document, provide a power- and resource-conservative solution to ambulatory pain monitoring. Operating multiple sensors for pain assessment may put a high demand for battery power, storage space, computing resources, and communication bandwidth on an ambulatory pain monitor. The triggered sensor activation and pain assessment may not only reduce active operation time of the corresponding device components, but also help ensure high-quality sensor data (e.g., a higher data resolution) be collected in a specific patient context (e.g., when the patient engage in a specific physical activity) and used for pain assessment. As such, the systems and methods discussed herein may improve pain assessment accuracy and system efficiency, but at lower operation cost. Additionally, through improved pain therapy based on patient individual need and therapy efficacy, battery longevity of an implantable device may be enhanced, or pain medication volume may be saved.

**[0035]** This summary is intended to provide an overview of subject matter of the present patent application. It is not intended to provide an exclusive or exhaustive explanation of the disclosure. The detailed description is included to provide further information about the present patent application. Other aspects of the disclosure will be apparent to persons skilled in the art upon reading and understanding the following detailed description and viewing the drawings that form a part thereof, each of which are not to be taken in a limiting sense.

#### BRIEF DESCRIPTION OF THE DRAWINGS

**[0036]** Various embodiments are illustrated by way of example in the figures of the accompanying drawings. Such embodiments are demonstrative and not intended to be exhaustive or exclusive embodiments of the present subject matter.

**[0037]** FIG. 1 illustrates, by way of example and not limitation, a neuromodulation system and portions of an environment in which the neuromodulation system may operate.

**[0038]** FIG. 2 illustrates, by way of example and not limitation, a block diagram of a pain management system.

**[0039]** FIG. 3 illustrates, by way of example and not limitation, a block diagram of another pain management system.

**[0040]** FIG. 4 illustrates, by way of example and not limitation, a portion of a pain management system for setting the operating mode of a second sensor circuit using a signal sensed from a first sensor circuit.

**[0041]** FIG. 5 illustrates, by way of example and not limitation, a method for managing pain of a patient.

**[0042]** FIG. 6 illustrates, by way of example and not limitation, a block diagram of an example machine upon which any one or more of the techniques discussed herein may perform.

#### DETAILED DESCRIPTION

**[0043]** In the following detailed description, reference is made to the accompanying drawings which form a part hereof, and in which is shown by way of illustration specific embodiments in which the invention may be practiced. These embodiments are described in sufficient detail to enable those skilled in the art to practice the invention, and it is to be understood that the embodiments may be combined, or that other embodiments may be utilized and that structural, logical and electrical changes may be made without departing from the spirit and scope of the present invention. References to “an”, “one”, or “various” embodiments in this disclosure are not necessarily to the same embodiment, and such references contemplate more than one embodiment. The following detailed description provides examples, and the scope of the present invention is defined by the appended claims and their legal equivalents.

**[0044]** Clinically, chronic pain may affect a patient's functional state such as motion control. Patient in pain may present with poor or unbalanced posture, abnormal gait pattern, restrained range-of-motion, or decreased intensity or duration of physical activities. Pain may also cause body to compensate, such that muscles, ligaments and nerves may move differently to adapt to the pain. Over time, some muscles may become chronically tight while other muscles weaken, and ligaments may stretch to accommodate uneven body motion. The compensatory changes in posture and the unbalanced motion pattern may gradually exacerbate the chronic pain and cause recurring injuries, resulting in a vicious pain cycle.

**[0045]** Chronic pain may also be associated with changes in patient physiological conditions. Pain may impair neuro-cardiac integrity. In the presence of pain, elevated sympathetic activity and/or withdrawal of parasympathetic activity may cause cardiovascular reactions, including constriction of peripheral blood vessels, increase in blood pressure, increase in heart rate, decrease in heart rate variability, and increase in cardiac force of contraction, among others. Alterations in autonomic function such as increased sympathetic tone may also affect cardiac electrical activity, such as changes in electrocardiography (ECG) morphology or timing. In another example, chronic pain may be associated with muscle tension. When muscles remain being contracted for an extended period of time, blood flow to the soft tissues, including muscles, tendons, and nerves in the back may be reduced. Close monitoring of patient muscle tension, such as detected from electromyography (EMG) or a mechanical contraction signal, may provide an objective assessment of pain, and may be used to improve pain therapy efficacy.

[0046] Disclosed herein are systems, devices, and methods for or assessing pain of a subject, and optionally programming pain therapy based on the pain assessment. In various embodiments, the present system may include a first sensor circuit to sense from the patient a first signal indicative of a functional state of the patient, a second sensor circuit to sense a second signal different from the first signal, and a controller circuit. The second signal may include a physiological signal or a functional signal. The controller circuit that may determine an operating mode of the second sensor circuit using the sensed first signal, trigger the second sensor circuit to sense the second signal under the determined operating mode, and generate a pain score using at least the second signal sensed under the determined operating mode. The pain score can be output to a patient or used for closed-loop control of a pain therapy.

[0047] The present system may be implemented using a combination of hardware and software designed to provide a closed-loop pain management regimen to increase therapeutic efficacy, increase patient satisfaction for neurostimulation therapies, reduce side effects, and/or increase device longevity. The present system may be applied in any neurostimulation (neuromodulation) therapies, including but not limited to SCS, DBS, PNS, FES, and Vagus Nerve Stimulation (VNS) therapies. In various examples, instead of providing closed-loop pain therapies, the systems, devices, and methods described herein may be used to monitor the patient and assess pain that either occurs intrinsically, or is induced by nerve block procedures or radiofrequency ablation therapies, among others. The patient monitoring may include generating recommendations to the patient or a clinician regarding pain treatment.

[0048] FIG. 1 illustrates, by way of example and not limitation, an example of a neuromodulation system 100 for managing pain of a subject such as a patient with chronic pain, and portions of an environment in which the neuromodulation system 100 may operate. The neuromodulation system 100 may include an implantable system 110 that may be associated with a body 199 of the subject, and an external system 130 in communication with the implantable system 110 via a communication link 120.

[0049] The implantable system 110 may include an ambulatory medical device (AMD), such as an implantable neuromodulator device (IND) 112, a lead system 114, and one or more electrodes 116. The IND 112 may be configured for subcutaneous implant in a patient's chest, abdomen, or other parts of the body 199. The IND 112 may be configured as a monitoring and diagnostic device. The IND 112 may include a hermetically sealed can that houses sensing circuitry to sense physiological or functional signals from the patient via sensing electrodes or ambulatory sensors associated with the patient and in communication with the IND 112. In some examples, the sensing electrodes or the ambulatory sensors may be included within the IND 112. The physiological or functional signals, when measured during a pain episode, may be correlative to severity of the pain. The IND 112 may characterize and quantify the pain, such as to determine onset, intensity, severity, duration, or patterns of the pain experienced by the subject. The IND 112 may generate an alert to indicate occurrence of a pain episode, pain exacerbation, or efficacy of pain therapy, and present the alert to a clinician.

[0050] The IND 112 may alternatively be configured as a therapeutic device for treating or alleviating the pain. In

addition to the pain monitoring circuitry, the IND 112 may further include a therapy unit that can generate and deliver energy or modulation agents to a target tissue. The energy may include electrical, magnetic, or other types of energy. In some examples, the IND 112 may include a drug delivery system such as a drug infusion pump that can deliver pain medication to the patient, such as morphine sulfate or ziconotide, among others.

[0051] The IND 112 may include electrostimulation circuitry that generates electrostimulation pulses to stimulate a neural target via the electrodes 116 operably connected to the IND 112. In an example, the electrodes 116 may be positioned on or near a spinal cord, and the electrostimulation circuitry may be configured to deliver SCS to treat pain. In another example, the electrodes 116 may be surgically placed at other neural targets such as a brain or a peripheral neural tissue, and the electrostimulation circuitry may be configured to deliver brain or peripheral stimulations. Examples of electrostimulation may include deep brain stimulation (DBS), trigeminal nerve stimulation, occipital nerve stimulation, vagus nerve stimulation (VNS), sacral nerve stimulation, sphenopalatine ganglion stimulation, sympathetic modulation, adrenal gland modulation, baroreceptor stimulation, or transcranial magnetic stimulation, among other peripheral nerve or organ stimulation.

[0052] In various examples, the electrodes 116 may be distributed in one or more leads of the lead system 114 electrically coupled to the IND 112. In an example, the lead system 114 may include a directional lead that includes at least some segmented electrodes circumferentially disposed about the directional lead. Two or more segmented electrodes may be distributed along a circumference of the lead. The actual number and shape of leads and electrodes may vary according to the intended application. Detailed description of construction and method of manufacturing percutaneous stimulation leads are disclosed in U.S. Pat. No. 8,019,439, entitled "Lead Assembly and Method of Making Same," and U.S. Pat. No. 7,650,184, entitled "Cylindrical Multi-Contact Electrode Lead for Neural Stimulation and Method of Making Same," the disclosures of which are incorporated herein by reference. The electrodes 116 may provide an electrically conductive contact providing for an electrical interface between the IND 112 and tissue of the patient. The neurostimulation pulses are each delivered from the IND 112 through a set of electrodes selected from the electrodes 116. In various examples, the neurostimulation pulses may include one or more individually defined pulses, and the set of electrodes may be individually definable by the user for each of the individually defined pulses.

[0053] Although the discussion herein with regard to the neuromodulation system 100 focuses on an implantable device such as the IND 112, this is meant only by way of example and not limitation. It is within the contemplation of the present inventors and within the scope of this document, that the systems, devices, and methods discussed herein may also be used for pain management via subcutaneous medical devices, wearable medical devices (e.g., wrist watch, patches, garment- or shoe-mounted device), or other external medical devices, or a combination of implantable, wearable, or other external devices. The therapy, such as electrostimulation or medical therapies, may be used to treat various neurological disorders other than pain, which by way of example and not limitation may include epilepsy,

obsessive compulsive disorder, tremor, Parkinson's disease, or dystonia, among other movement and affective disorders.

[0054] The external system 130 may be communicated with the IND 112 via a communication link 120. The external system 130 may include a dedicated hardware/software system such as a programmer, a remote server-based patient management system, or alternatively a system defined predominantly by software running on a standard personal computer. The external system 130 may be configured to control the operation of the IND 112, such as to program the IND 112 for delivering neuromodulation therapy. The external system 130 may additionally receive via the communication link 120 information acquired by IND 112, such as one or more physiological or functional signals. In an example, the external system 130 may determine a pain score based on the physiological or functional signals received from the IND 112, and program the IND 112 to deliver pain therapy in a closed-loop fashion. Examples of the external system and neurostimulation based on pain score are discussed below, such as with reference to FIGS. 2-3.

[0055] The communication link 120 may include one or more communication channels and intermediate devices between the external system and the IND, such as a wired link, a telecommunication link such as an internet connection, or a wireless link such as one or more of an inductive telemetry link, a radio-frequency telemetry link. The communication link 120 may provide for data transmission between the IND 112 and the external system 130. The transmitted data may include, for example, real-time physiological or functional signals acquired by and stored in the IND 112, therapy history data, data indicating device operational status of the IND 112, one or more programming instructions to the IND 112 which may include configurations for sensing physiologic signal or stimulation commands and stimulation parameters, or device self-diagnostic test, among others. In some examples, the IND 112 may be coupled to the external system 130 further via an intermediate control device, such as a handheld external remote control device to remotely instruct the IND 112 to generate electrical stimulation pulses in accordance with selected stimulation parameters produced by the external system 130.

[0056] Portions of the IND 112 or the external system 130 may be implemented using hardware, software, firmware, or combinations thereof. Portions of the IND 112 or the external system 130 may be implemented using an application-specific circuit that may be constructed or configured to perform one or more particular functions, or may be implemented using a general-purpose circuit that may be programmed or otherwise configured to perform one or more particular functions. Such a general-purpose circuit may include a microprocessor or a portion thereof, a microcontroller or a portion thereof, or a programmable logic circuit, or a portion thereof. For example, a "comparator" may include, among other things, an electronic circuit comparator that may be constructed to perform the specific function of a comparison between two signals or the comparator may be implemented as a portion of a general-purpose circuit that may be driven by a code instructing a portion of the general-purpose circuit to perform a comparison between the two signals.

[0057] FIG. 2 illustrates, by way of example and not limitation, an example of a pain management system 200, which may be an embodiment of the neuromodulation

system 100. The pain management system 200 may assess pain of a subject using functional or physiological signals. As illustrated in FIG. 2, the pain management system 200 may include a first sensor circuit 210, a second sensor circuit 220, a pain analyzer circuit 230, a controller circuit 240, and a user interface 250. In some examples, the pain analyzer circuit 230 may be part of the controller circuit 240. The pain management system 200 may additionally include a therapy circuit 260 to deliver pain therapy such as according to the pain assessment.

[0058] The first sensor circuit 210 may be configured to sense a first signal indicative of functional state of the subject. The first sensor circuit 210 may be coupled to a motion sensor to sense at least one functional signal. The motion sensor may be an ambulatory sensor, such as an implantable or wearable sensor associated with the patient. Additionally or alternatively, the motion sensor may be a stationary sensor, such as mounted in a room or attached to furniture, to detect one or more functional signals from the patient when the patient enters, or remains within, an environment of patient daily life.

[0059] The first sensor circuit 210 may include sense amplifier circuit that may pre-process the sensed signals, including, for example, amplification, digitization, filtering, or other signal conditioning operations. In an example, the functional signal may include a motor activity signal. Examples of the motor activity signal may include, but are not limited to, patient posture, gait, balance, or physical activity signals, among others. In another example, the functional signal may include a sleep state signal that contains information about sleep disturbance. Chronic pain patients may experience frequent disrupted sleep or change of sleep patterns. The motion sensor may detect frequency or duration of sleep position switch, sleep incline, or other indicators of sleep quality. Examples of the sensors for detecting various functional signals are discussed below, such as with reference to FIG. 4.

[0060] The second sensor circuit 220 may sense from the subject a second signal different from the first signal sensed from the first sensor circuit 210. The second sensor circuit 220 may be coupled to an ambulatory sensor or a stationary sensor to sense one or more physiological signals or one or more functional signals different from the first signal. The physiological signals may reveal characteristic signal properties in response to an onset, intensity, severity, duration, or patterns of pain. Information of physiological signal changes may be used to assess patient pain.

[0061] Pain may impair neuro-cardiac integrity. In the presence of pain, elevated sympathetic activity and/or withdrawal of parasympathetic activity may cause cardiovascular reactions, such as increased heart rate, enhanced cardiac force, and changes in electrical activity. Examples of the cardiac signals can include a heart rate signal, a pulse rate signal, a heart rate variability signal, electrocardiograph (ECG) or intracardiac electrogram, cardiovascular pressure signal, or heart sounds signal, among others.

[0062] In addition to or in lieu of the cardiac signals, the second sensor circuit 220 may sense one or more of a galvanic skin response (GSR) signal, an electrodermal activity (EDA) signal, a skin temperature signal, an electromyogram (EMG) signal, an electroencephalogram (EEG) signal, a magnetoencephalogram (MEG) signal, a hemodynamic signal such as a blood flow signal, a blood pressure signal, a blood perfusion signal, a photoplethysmography (PPG)

signal, a heart sound signal, or a saliva production signal indicating the change of amount of saliva production, among others. The physiological signals may additionally include pulmonary, neural, or biochemical signals. Examples of pulmonary signals may include a respiratory signal, a thoracic impedance signal, or a respiratory sounds signal. Examples of biochemical signals may include blood chemistry measurements or expression levels of one or more biomarkers, which may include, by way of example and not limitation, B-type natriuretic peptide (BNP) or N-terminal pro b-type natriuretic peptide (NT-proBNP), serum cytokine profiles, P2X4 receptor expression levels, gamma-aminobutyric acid (GABA) levels, TNF $\alpha$  and other inflammatory markers, cortisol, adenosine, Glial cell-derived neurotrophic factor (GDNF), Nav 1.3, Nav 1.7, or Tetrahydrobiopterin (BH4) levels, among other biomarkers.

[0063] The pain analyzer circuit 230 may generate a pain score using at least the second signal received from the second sensor circuit 220. In some examples, the pain analyzer circuit 230 generate the pain score further using the functional signal sensed from the first sensor circuit 210. The pain analyzer circuit 230 may be implemented as a part of a microprocessor circuit, which may be a dedicated processor such as a digital signal processor, application specific integrated circuit (ASIC), microprocessor, or other type of processor for processing information including physical activity information. Alternatively, the microprocessor circuit may be a general-purpose processor that may receive and execute a set of instructions of performing the functions, methods, or techniques described herein.

[0064] As illustrated in FIG. 2, the pain analyzer circuit 230 may be coupled to a controller circuit 240 that controls the sensor-based pain assessment. In some examples, the pain analyzer circuit 230 may be part of the controller circuit 240. The controller circuit 240 may receive the first signal sensed from the first sensor circuit 210. The controller circuit 240 includes an operating mode control 242 that may determine an operating mode of the second sensor circuit 220 using the received first signal. The operating mode controls the data acquisition and data processing at the second sensor circuit 220, and may include an activation or deactivation of sensor data acquisition, or a data acquisition rate such as a sampling rate or a digitization resolution. Using the first sensor signal to trigger activation and to set an operating mode of the second sensor may help improve system or device function of chronic and ambulatory. Activation and operation of multiple sensors for physiological data acquisition can be power- and memory-demanding, and pain assessment may require substantial amount of computing resource. The activation of and operating mode triggered by the first sensor, such as controlled by the controller circuit 240, may reduce the activation time of the second sensor, conserve the device power and computing resources, and thus reduces the operational cost.

[0065] The operating mode control 242 may compare the first signal to a condition, such as a threshold or a value range. Based on the comparison, the operating mode control 242 may determine the operating mode of the second sensor circuit 220, such as whether to activate or deactivate data acquisition, time of data acquisition, or a sampling rate for acquiring the second signal. The comparison may indicate an onset of a pain episode or worsening of pain. Activating the data acquisition of the second signal and pain assessment using the second signal may more reliably confirm the pain

episode or the worsening of pain. In some examples, the comparison may additionally or alternatively be used to prescreen the second sensor to determine a proper time to acquire data such as to avoid interferences or noise. This may allow for high-quality data being used in pain assessment. Examples of setting the operating mode of the second sensor circuit using the first sensed signal are discussed as follows, such as with reference to FIG. 4.

[0066] The pain analyzer circuit 230 and the controller circuit 240 may each include respective circuit sets comprising one or more other circuits or sub-circuits. In an example as illustrated in FIG. 2, the pain analyzer circuit 230 may comprise a signal metric generator 231 and a pain score generator 232. These circuits or sub-circuits may, alone or in combination, perform the functions, methods or techniques described herein. In an example, hardware of the circuit set may be immutably designed to carry out a specific operation (e.g., hardwired). In an example, the hardware of the circuit set may include variably connected physical components (e.g., execution units, transistors, simple circuits, etc.) including a computer readable medium physically modified (e.g., magnetically, electrically, moveable placement of invariant massed particles, etc.) to encode instructions of the specific operation. In connecting the physical components, the underlying electrical properties of a hardware constituent are changed, for example, from an insulator to a conductor or vice versa. The instructions enable embedded hardware (e.g., the execution units or a loading mechanism) to create members of the circuit set in hardware via the variable connections to carry out portions of the specific operation when in operation. Accordingly, the computer readable medium is communicatively coupled to the other components of the circuit set member when the device is operating. In an example, any of the physical components may be used in more than one member of more than one circuit set. For example, under operation, execution units may be used in a first circuit of a first circuit set at one point in time and reused by a second circuit in the first circuit set, or by a third circuit in a second circuit set at a different time.

[0067] The signal metric generator 231 may generate one or more signal metrics from the sensed second signal under the determined operating mode. The signal metrics may include statistical parameters extracted from the sensed signal, such as signal mean, median, or other central tendency measures or a histogram of the signal intensity, among others. The signal metrics may additionally or alternatively include morphological parameters such as maximum or minimum within a specific time period such as a cardiac cycle, positive or negative slope or higher order statistics, or signal power spectral density at a specific frequency range, among other morphological parameters. The signal metrics may additionally include timing information such as a time interval between a first characteristic point in one signal and a second characteristic point in another signal. In various examples, the signal metric generator 231 may extract from the second signal, sensed under the determined operating mode, one or more ECG metrics such as heart rate, heart rate variability, timing relationship between characteristic ECG components (e.g., P wave to R wave intervals), PPG metrics, blood pressure metrics, pulse wave transit metrics, EMG metrics, muscle tightness metrics, muscle shortening metrics, EEG metrics, GSR metrics, among others. In some examples, the signal metric generator circuit 231 may additionally generate from the sensed first signal a plurality of

functional signal metrics indicative of patient functional state such as motor control or kinetics. By way of example and not limitation, the motor activity metrics may include metrics of posture, gait, physical activity, balance, or range-of-motion.

**[0068]** The pain score generator **232** may generate a pain score using the signal metrics generated from the second signal sensed under the determined operating mode, or optionally along with the signal metrics generated from the first functional signal metrics. The pain score can be represented as a numerical or categorical value that quantifies the patient's overall pain symptom. In an example, a composite signal metric may be generated using a combination of a plurality of the signal metrics respectively weighted by weight factors. The combination can be linear or nonlinear. The pain score generator **232** may compare the composite signal metric to one or more threshold values or range values, and assign a corresponding pain score (such as numerical values from 0 to 10) based on the comparison.

**[0069]** In another example, the pain score generator **232** may compare the signal metrics to their respective threshold values or range values, assign corresponding signal metric-specific pain scores based on the comparison, and compute a composite pain score using a linear or nonlinear fusion of the signal metric-specific pain scores weighted by their respective weight factors. In an example, the threshold can be inversely proportional to signal metric's sensitivity to pain. A signal metric that is more sensitive to pain may have a corresponding lower threshold and a larger metric-specific pain score, thus plays a more dominant role in the composite pain score than another signal metric that is less sensitive to pain. Examples of the fusion algorithm may include weighted averages, voting, decision trees, or neural networks, among others. The pain score generated by the pain score generator **232** may be output to a system user or a process.

**[0070]** The user interface **250** may include an input circuit and an output circuit. In an example, at least a portion of the user interface **250** may be implemented in the external system **130**. The input circuit may enable a system user to program the parameters used for sensing the physiological signals, generating signal metrics, or generating the pain score. The input circuit may be coupled to one or more input devices such as a keyboard, on-screen keyboard, mouse, trackball, touchpad, touch-screen, or other pointing or navigating devices. In some example, the input device may be incorporated in a mobile device such as a smart phone or other portable electronic device with a mobile application ("App"). The mobile App may enable a patient to provide pain description or quantified pain scales during the pain episodes. In an example, the input circuit may enable a user to confirm, reject, or edit the programming of the therapy circuit **260**, such as parameters for electrostimulation, as to be discussed in the following.

**[0071]** The output circuit may be coupled to a display to present to a system user such as a clinician the pain score, physiological and functional signals sensed from the sensor circuits **210** and **220**, trends of the signal metric, or any intermediary results for pain score calculation such as the signal metric-specific pain scores. In some examples, a clinician may assess efficacy of pain treatment using the sensed physiological and functional signals. For example, a patient may become too active too quickly after improvement in pain symptoms or having pain relief. The output of

the functional signal such as physical activity trend may aid a clinician in advising the patient to decrease activity or to track an acceptable activity routine through the treatment process. The information may be presented in a table, a chart, a diagram, or any other types of textual, tabular, or graphical presentation formats, for displaying to a system user. The presentation of the output information may include audio or other human-perceptible media format. In an example, the output circuit may generate alerts, alarms, emergency calls, or other means of warnings to signal the system user about the detected pain score.

**[0072]** The therapy circuit **260** may be configured to deliver a therapy to the patient based on the pain score generated by the pain score generator **232**. The therapy circuit **260** may include an electrostimulator configured to generate electrostimulation energy to treat pain, or to alleviate side effects introduced by the electrostimulation of the target tissue. In an example, the electrostimulator may deliver spinal cord stimulation (SCS) via electrodes electrically coupled to the electrostimulator. The electrodes may be surgically placed at a region at or near a spinal cord tissue, which may include, by way of example and not limitation, dorsal column, dorsal horn, spinal nerve roots such as the dorsal nerve root, and dorsal root ganglia. The SCS may be in a form of stimulation pulses that are characterized by pulse amplitude, pulse width, stimulation frequency, duration, on-off cycle, pulse shape or waveform, temporal pattern of the stimulation, among other stimulation parameters. Examples of the stimulation pattern may include burst stimulation with substantially identical inter-pulse intervals, or ramp stimulation with incremental inter-pulse intervals or with decremental inter-pulse intervals. In some examples, the frequency or the pulse width may change from pulse to pulse. The electrostimulator may additionally or alternatively deliver electrostimulation to other target tissues such as peripheral nerves tissues. In an example, the electrostimulator may deliver transcutaneous electrical nerve stimulation (TENS) via detachable electrodes that are affixed to the skin. Other examples of electrostimulation may include deep brain stimulation (DBS), trigeminal nerve stimulation, occipital nerve stimulation, vagus nerve stimulation (VNS), sacral nerve stimulation, sphenopalatine ganglion stimulation, sympathetic modulation, adrenal gland modulation, baroreceptor stimulation, or transcranial magnetic stimulation, among other peripheral nerve or organ stimulation.

**[0073]** The therapy circuit **260** may additionally or alternatively include a drug delivery system, such as an intrathecal drug delivery pump that may be surgically placed under the skin, which may be programmed to inject medication through a catheter to the area around the spinal cord. Other examples of drug delivery system may include a computerized patient-controlled analgesia pump that may deliver the prescribed pain medication to the patient such as via an intravenous line.

**[0074]** The controller circuit **240** may control the therapy circuit **260** to generate and deliver pain therapy, such as neurostimulation energy, according to the pain score received from the pain score generator **232**. The controller circuit **240** may control the generation of electrostimulation pulses according to specific stimulation parameters. Additionally or alternatively, the controller circuit **240** may control the therapy circuit **260** to deliver electrostimulation pulses via specific electrodes. In an example of pain management via SCS, a plurality of segmented electrodes, such

as the electrodes 116, may be distributed in one or more leads. The controller circuit 240 may configure the therapy circuit 260 to deliver electrostimulation pulses via a set of electrodes selected from the plurality of electrodes. The electrodes may be manually selected by a system user or automatically selected based on the pain score.

[0075] FIG. 3 illustrates, by way of example and not limitation, another example of a pain management system 300, which may be an embodiment of the neuromodulation system 100 or the pain management system 200. The pain management system 300 may include an implantable neuromodulator 310 and an external system 320, which may be, respectively, embodiments of the IND 112 and the external system 130 as illustrated in FIG. 1. The external system 320 may be communicatively coupled to the implantable neuromodulator 310 via the communication link 120.

[0076] The implantable neuromodulator 310 may include several components of the pain management system 200 as illustrated in FIG. 2, including the first sensor circuit 210, the second sensor circuit 220, the pain analyzer circuit 230, the controller circuit 240, and the therapy circuit 260. As previously discussed, in some examples, the pain analyzer circuit 230 may be part of the controller circuit 240. The implantable neuromodulator 310 may include a memory circuit 370 configured to store sensor signals or signal metrics such as generated by the first sensor circuit 210, the second sensor circuit 220, the signal metric generator 231, and the pain scores such as generated by the pain score generator 232. Data storage at the memory circuit 370 may be continuous, periodic, or triggered by a user command or a specific event. The memory circuit 370 may store weight factors used for generating the composite pain score, such as at the pain score generator 232. The weight factors may be provided by a system user, or alternatively be automatically determined or adjusted such as based on the corresponding signal metrics' reliability in representing an intensity of the pain.

[0077] The controller circuit 240 may control the generation of electrostimulation pulses according to specific stimulation parameters. The stimulation parameters may be provided by a system user. Alternatively, the stimulation parameters may be automatically determined based on the intensity, severity, duration, or pattern of pain, which may be subjectively described by the patient, or automatically quantified based on the signals sensed by the sensor circuits 210 and 220. For example, when a patient-described or sensor-indicated pain quantification exceeds a respective threshold value or falls within a specific range indicating elevated pain, the electrostimulation energy may be increased to provide stronger pain relief. Increased electrostimulation energy may be achieved by programming a higher pulse intensity, a higher frequency, or a longer stimulation duration or "on" cycle, among others. Conversely, when a patient-described or sensor-indicated pain quantification falls below a respective threshold value or falls within a specific range indicating no pain or mild pain, the electrostimulation energy may be decreased.

[0078] The implantable neuromodulator 310 may receive the information about electrostimulation parameters and the electrode configuration from the external system 320 via the communication link 120. Additional parameters associated with operation of the therapy circuit 260, such as battery status, lead impedance and integrity, or device diagnostic of the implantable neuromodulator 310, may be transmitted to

the external system 320. The controller circuit 240 may control the generation and delivery of electrostimulation using the information about electrostimulation parameters and the electrode configuration from the external system 320. Examples of the electrostimulation parameters and electrode configuration may include: temporal modulation parameters such as pulse amplitude, pulse width, pulse rate, or burst intensity; morphological modulation parameters respectively defining one or more portions of stimulation waveform morphology such as amplitude of different phases or pulses included in a stimulation burst; or spatial modulation parameters such as selection of active electrodes, electrode combinations which define the electrodes that are activated as anodes (positive), cathodes (negative), and turned off (zero), and stimulation energy fractionalization which defines amount of current, voltage, or energy assigned to each active electrode and thereby determines spatial distribution of the modulation field.

[0079] In an example, the controller circuit 240 may control the generation and delivery of electrostimulation in a closed-loop fashion by adaptively adjusting one or more stimulation parameters or stimulation electrode configuration based on the pain score. For example, if the score exceeds the pain threshold (or falls within a specific range indicating an elevated pain), then the first electrostimulation may be delivered. Conversely, if the composite pain score falls below a respective threshold value (or falls within a specific range indicating no pain or mild pain), then a second pain therapy, such as second electrostimulation may be delivered. The first electrostimulation may differ from the second electrostimulation with respect to at least one of the stimulation energy, pulse amplitude, pulse width, stimulation frequency, duration, on-off cycle, pulse shape or waveform, electrostimulation pattern such as electrode configuration or energy fractionalization among active electrodes, among other stimulation parameters. In an example, the first electrostimulation may have higher energy than the second electrostimulation, such as to provide stronger effect of pain relief. Examples of increased electrostimulation energy may include a higher pulse intensity, a higher frequency, or a longer stimulation duration or "on" cycle, among others.

[0080] The parameter adjustment or stimulation electrode configuration may be executed continuously, periodically at specific time, duration, or frequency, or in a commanded mode upon receiving from a system user a command or confirmation of parameter adjustment. In some examples, the closed-loop control of the electrostimulation may be further based on the type of the pain, such as chronic or acute pain. In an example, the pain analyzer circuit 230 may trend the signal metric over time to compute an indication of abruptness of change of the signal metrics, such as a rate of change over a time period. The pain episode may be characterized as acute pain if the signal metric changes abruptly (e.g., the rate of change of the signal metric exceeding a threshold), or as chronic pain if the signal metric changes gradually (e.g., the rate of change of the signal metric falling below a threshold). The controller circuit 240 may control the therapy circuit 260 to deliver, withhold, or otherwise modify the pain therapy in accordance with the pain type. For example, incidents such as toe stubbing or bodily injuries may cause abrupt changes in certain signal metrics, but no adjustment of the closed-loop pain therapy is deemed necessary. On the contrary, if the pain analyzer

circuit 230 detects chronic pain characterized by gradual signal metric change, then the closed-loop pain therapy may be delivered accordingly.

[0081] The external system 320 may include the user interface 250, a weight generator 322, and a programmer circuit 324. The weight generator 322 may generate weight factors used by the pain score generator 232 to generate the pain score. The weight factors may indicate the signal metrics' reliability in representing an intensity of the pain. A sensor metric that is more reliable, or more sensitive or specific to the pain, would be assigned a larger weight than another sensor metric that is less reliable, or less sensitive or specific to the pain. In an example, the weight factors may be proportional to correlations between a plurality of quantified pain scales (such as reported by a patient) and measurements of the measurements of the signal metrics corresponding to the plurality of quantified pain scales. A signal metric that correlates with the pain scales is deemed a more reliable signal metric for pain quantification, and is assigned a larger weight factor than another signal metric less correlated with the quantified pain scales. In another example, the weight generator 322 may determine weight factors using the signal sensitivity to pain. The signal metrics may be trended over time, such as over approximately six months. The signal sensitivity to pain may be represented by a rate of change of the signal metrics over time during a pain episode. The signal sensitivity to pain may be evaluated under a controlled condition such as when the patient posture or activity is at a specific level or during specific time of the day. The weight generator 322 may determine weight factors to be proportional to signal metric's sensitivity to pain.

[0082] The programmer circuit 324 may produce parameter values for operating the implantable neuromodulator 310, including parameters for sensing the signals and generating signal metrics, and parameters or electrode configurations for electrostimulation. In an example, the programmer circuit 324 may generate the stimulation parameters or electrode configurations for SCS based on the pain score produced by the pain score generator 232. Through the communication link 120, the programmer circuit 324 may continuously or periodically provide adjusted stimulation parameters or electrode configuration to the implantable neuromodulator 210. By way of non-limiting example and as illustrated in FIG. 3, the programmer circuit 324 may be coupled to the user interface 250 to allow a user to confirm, reject, or edit the stimulation parameters, sensing parameters, or other parameters controlling the operation of the implantable neuromodulator 210. The programmer circuit 324 may also adjust the stimulation parameter or electrode configuration in a commanded mode upon receiving from a system user a command or confirmation of parameter adjustment.

[0083] The programmer circuit 324, which may be coupled to the weight generator 322, may initiate a transmission of the weight factors generated by the weight generator 322 to the implantable neuromodulator 310, and store the weight factors in the memory circuit 370. In an example, the weight factors received from the external system 320 may be compared to previously stored weight factors in the memory circuit 370. The controller circuit 240 may update the weight factors stored in the memory circuit 370 if the received weight factors are different from the stored weights. The pain analyzer circuit 230 may use the

updated weight factors to generate a pain score. In an example, the update of the stored weight factors may be performed continuously, periodically, or in a commanded mode upon receiving a command from a user.

[0084] In some examples, the pain score may be used by a therapy unit (such as an electrostimulator) separated from the pain management system 300. In various examples, the pain management system 300 may be configured as a monitoring system for pain characterization and quantification without delivering closed-loop electrostimulation or other modalities of pain therapy. The pain characterization and quantification may be provided to a system user such as the patient or a clinician, or to a process including, for example, an instance of a computer program executable in a microprocessor. In an example, the process includes computer-implemented generation of recommendations or an alert to the system user regarding pain medication (e.g., medication dosage and time for taking a dose), electrostimulation therapy, or other pain management regimens. The therapy recommendations or alert may be based on the pain score, and may be presented to the patient or the clinician in various settings including in-office assessments (e.g. spinal cord stimulation programming optimization), in-hospital monitoring (e.g. opioid dosing during surgery), or ambulatory monitoring (e.g. pharmaceutical dosing recommendations).

[0085] In an example, in response to the pain score exceeding a threshold that indicates an elevated pain symptom, an alert may be generated and presented at the user interface 250 to remind the patient to take pain medication. In another example, therapy recommendations or alerts may be based on information about wearing-off effect of pain medication, which may be stored in the memory circuit 370 or received from the user interface 250. When the drug effect has worn off, an alert may be generated to remind the patient to take another dose or to request a clinician review of the pain prescription. In yet another example, before a pain therapy such as neurostimulation therapy is adjusted (such as based on the pain score) and delivered to the patient, an alert may be generated to forewarn the patient or the clinician of any impending adverse events. This may be useful as some pain medication may have fatal or debilitating side effects. In some examples, the pain management system 300 may identify effect of pain medication addiction such as based on functional and physiological signals. An alert may be generated to warn the patient about effects of medication addiction and thus allow medical intervention.

[0086] FIG. 4 illustrates, by way of example and not limitation, an example of a portion of a pain management system for setting the operating mode of the second sensor circuit 220 using a signal sensed from a first sensor circuit 420. The system portion may include one or more motion sensors 410, a first sensor circuit 420 which an embodiment of the first sensor circuit 210, the controller circuit 240, and the signal second sensor circuit 220. The signals acquired at the second sensor circuit 220 under the operating mode may be used by the pain management system 200 or 300 to characterize and quantify patient.

[0087] By way of example and not limitation, the motion sensors 410 may include one or more of sensors 411-415 that may sense patient functional state. The physical activity sensor 411 may include an accelerometer configured to sense a physical activity signal. The accelerometer may be single-axis or multi-axis accelerometer. The posture sensor

**412** may include a tilt switch or a single- or multi-axis accelerometer associated with the patient. For example, the posture sensor may be disposed external to the body or implanted inside the body. Posture may be represented by, for example, a tilt angle. In some examples, posture or physical activity information may be derived from thoracic impedance information. The motion range sensor **413** may include an accelerometer positioned on patient extremities or patient body trunk to detect a range-of-motion. The gait sensor **414** may detect patient gait or a state of balance. Examples of the gait sensors may include accelerometer, gyroscope (which may be a one-, two-, or three-axis gyroscope), magnetometer (e.g., a compass), inclinometers, goniometers, electromagnetic tracking system (ETS), a global positioning system (GPS) sensor, sensing fabric, force sensor, strain gauges, and sensors for electromyography (EMG). The sensors may be configured for wearing at, or attaching to, patient foot, ankle, leg, waist, or other parts on the torso or the extremities. In an example, the gait sensor **414** may include an insole force sensor for placement inside a shoe or a boot. The insole force sensor may take the form of a strain gauge, a piezoelectric sensor, or a capacitive sensor, among others. The insole force sensor may be wirelessly coupled to the IND **310** or the pain analyzer circuit **230**. The first sensor circuit **210** may analyze force distribution on a patient's foot, and generate an indicator of gait. The sleep state sensor **415** may include an accelerometer, a piezoelectric sensor, biopotential electrodes and sensors, or other sensors to detect the sleep state of the patient.

**[0088]** The motion sensors **410** may be associated with a patient in various manners. In an example, one or more of the motion sensors **410** may be implantable sensors configured for subcutaneous implantation at various body locations. One or more of the motion sensors **410** may be wearable sensors configured to be worn on the head, wrist, hand, foot, ankle, waist, or other parts of the body, or apparel-mounted sensor that may be mounted on a garment, a footwear, a headwear, or one or more accessories carried by the patient, such as a pendant, a necklace, or a bracelet. In another example, one or more of the motion sensors **410** may be stationary sensors configured for placement in patient environment, such as at a bedside, in a room at patient home, or in a testing room at a clinic or medical facility. In an example, the motion sensors may be mounted on a chair, a bed (e.g., under or attached to a mattress), or a fixture in a patient's environment. Unlike the implantable, wearable, or apparel-mounted sensors which are ambulatory in nature, the stationary sensors are configured to detect one or more functional signals when the patient enters, or remains within, an environment within the scope of surveillance of the stationary sensor. In an example, the stationary sensors may include a camera or a video recorder configured to capture an image, an image sequence, or a video of the patient at a specific physical state, such as sitting, standing, walking, or doing physical activities. In an example, the camera may be an infrared camera. In an example, the camera is a digital camera that may generate digital data representation of an image or a video sequence.

**[0089]** In some examples, one or more of the motion sensors **410** may be incorporated in a mobile device, such as a smart phone, a wearable device, a fitness band, a portable health monitor, a tablet, a laptop computer, among other portable computerized device. For example, one or more of an accelerometer, a gyroscope, a magnetometer, a GPS sensor,

or a camera that sense motor activity signals may be embedded in a mobile device. The mobile device may be communicatively coupled to the IND **310** or the pain analyzer circuit **230** via a communication link such as a universal serial bus connection, a Bluetooth protocol, Ethernet, IEEE 802.11 wireless, an inductive telemetry link, or a radio-frequency telemetry link, among others.

**[0090]** The first sensor circuit **420**, an embodiment of the first sensor circuit **210**, may be coupled to the motion sensors **410** via wired or wireless connections. The first sensor circuit **420** may include a sense amplifier circuit that may pre-process the sensed functional signal, and a feature extractor circuit **421** that may extract one or more motor activity features from the processed functional signals. In an example, features extracted from the physical activity signal may include one or more of activity intensity, activity duration, or a transition time between different types of activities. A decrease in activity intensity or duration from an activity baseline such as established using patient historical activity signals, or less frequent transition or an increase in transition time from one activity to another may indicate pain suffered by the patient. In another example, features extracted from the posture signal may include body position during sitting, standing, or walking. A decrease in activity intensity or duration from an activity baseline such as established using patient historical activity signals, or less frequent transition or an increase in transition time from one activity to another may indicate pain suffered by the patient. In an example, features extracted from the motion range signal may include lumbar forward flexion, shoulder flexion, elbow flexion, rotation of arm and elbow joint, trunk-pelvis rotation, or other motor control and kinematic features. The motion range feature may include indication of smoothness of motion, such as a rate or a pattern of change in motion with respect to time, or with respect to angular velocity, etc. In another example, features extracted from the gait signal or balance signal may include velocity, time to peak velocity, step length, stride length, stride width, swing time, single limb support time, double limb stance, gait autonomy, cadence, among other measurements. In yet another example, features extracted from the sleep state signal may include sleep incline, sleep sidedness, frequency of sleep position switch, or other sleep quality or sleep disturbance metrics. For example, an increase in sleep incline, or enhanced frequency of body position switches during sleep, or reduced sleep duration are indicators of increase pain. The sleep state features, when satisfying a condition that indicates occurrence or aggravation of a pain episode, may trigger one or more other sensors to sense physiological or functional signals. In an example, if the frequency of sleep position switch exceeds a threshold, or if the sleep duration at a sleep position falls below a threshold (e.g., less than 5-15 seconds), sleep disturbance is indicated, which may trigger other sensors for sensing heart rate, respiration rate, jaw clench, or other physiological or functional responses. The sensed response may be used to distinguish between normal sleep patterns (e.g., sleep position change) and abnormal sleep patterns caused by or otherwise associated with acute pain.

**[0091]** Measurements of the extracted feature may be trended over time. The comparator **422** may compare the extracted feature trend to one or more thresholds or one or more value ranges to determine patient functional state. The operating mode control **242** in the controller circuit **240** may

determine an operating mode for the second sensor circuit 220 according to the comparison. In an example, the comparator 422 may compare one or more features extracted from the physical activity signal to determine patient physical activity level. Physical activity level may indicate presence or severity of pain. Patient in pain are generally less active, such that periods of activity are generally shorter and activity intensity is generally lower. If the comparison at the comparator 422 indicates a low physical activity level (in activity intensity or duration), then a pain episode or precursor of pain has likely occurred. The operating mode control 242 may activate the second sensor circuit 220 to initiate sensing signals such as cardiac, pulmonary, muscular, or neurological signals. However, if the comparison at the comparator 422 indicates a high physical activity level, then the patient is not likely experiencing pain. The operating mode control 242 may at least temporarily deactivate the second sensor circuit 220 from sensing data if the second sensor circuit 220 is in an active data-acquisition mode, or control the second sensor circuit 220 to withhold data acquisition.

[0092] In some examples, the extracted feature of physical activity may be measured during a specified time period of daytime or nighttime, or in a specific context such as when the patient is asleep. For example, if a high physical activity level is detected by the comparator 422 using the physical activity features extracted during a period of nighttime, or the high physical activity level is accompanied a detection of sleep such as detected by the sleep state sensor 415, the detected high physical activity level may indicate an onset of pain, worsening of pain, or undesirable pain treatment. The operating mode control 242 may activate the second sensor circuit 220 or acquire the data at a high data acquisition rate.

[0093] The first sensor circuit 422 may include a pattern detector 423 to detect a physical activity pattern using measurements of the extracted feature over time, such as collected within a specific time period during daytime or nighttime. The activity pattern may indicate the temporal variation of the physical activity during the specific time period. The comparator 422 may compare the detected physical activity pattern to a physical activity template representing a physical activity pattern under a known, controlled condition, such as a baseline pain-free condition. The physical activity template may be generated using the historical activity data from the same patient, or using activity data from a patient population. The comparator 422 may compute a dissimilarity measure, such as a distance measure, between the detected physical activity pattern and the physical activity template representing activity pattern during a pain-free condition. For example, pain patients tend to decrease activity during the course of a day, while healthy subjects generally have more stable daily activity levels. The pattern detector 423 may compute a decay rate of activity level during a time period (such as during a 12-hour period from morning to evening), and the comparator 422 may determine a dissimilarity of the decay rate of the detected physical activity and the decay rate of the physical activity template. If the dissimilarity exceeds a threshold, then the detected physical activity pattern indicates a high likelihood of pain. The operating mode control 242 may activate the second sensor circuit 220, or acquire the data at a high data rate mode. In some examples, the physical activity template may represent physical activity pattern under other known conditions, such as when the patient is in pain, walking,

sitting still, or any other form of activity. In another example, the physical activity template may represent patient regular activity (e.g. daily jog) during a particular period of day. If the comparator 422 determines a dissimilarity measure indicating that the regularly activity is missing from the detected physical activity pattern at the particular period of day, it may indicate that the patient is experiencing pain, which causes an absence of regular activity. The operating mode control 242 may activate the second sensor circuit 220, or acquire the data at a high data rate mode.

[0094] In addition to or in lieu of activation or deactivation of the second sensor circuit 220, the operating mode control 242 may adjust data acquisition rate of the second sensor circuit 220 based on the comparison at the comparator 422, which may include, by way of example and not limitation, sampling rate, digitization resolution, or time and duration of data acquisition period. For example, if the comparison at the comparator 422 indicates a decreased physical activity level indicating a likelihood of pain onset or worsening pain, the operating mode control 242 may control the second sensor circuit 220 to acquire data at a higher sampling rate or a higher digitization resolution, or with a longer data acquisition time period. This may help preserve the information of patient response to pain, and may improve pain assessment accuracy at the pain analyzer circuit 230. In an example, the second sensor circuit 220 may remain active acquiring data, or remain in high sampling rate or high resolution mode until the physical activity level stabilizes or exceeds a threshold indicating a pain relief or improvement. If the comparison at the comparator 422 indicates a high physical activity level, then the operating mode control 242 may reduce the sampling rate or the digitization resolution for the second sensor circuit 220, or control the second sensor circuit 220 to acquire data during a shorter data acquisition period. The operating mode control 242 may additionally or alternatively adjust data pre-processing of the data acquired by the second sensor circuit 220 based on the physical activity level, such as adjusting one or more parameters of signal filters including cutoff frequencies of a passband.

[0095] Operating mode of the second sensor as controlled by the physical activity level or other functional signals such as gait, balance, posture, range-of-motion, or sleep state may offer several benefits. Power and computing resources may be conserved by reducing the total activation time of second sensor, such as when the physical activity or other functional signals indicating a low likelihood of pain. The device power and computing resources may be reserved for sensor data collection and analysis in case of an elevated likelihood of pain such as indicated by reduced activity level. This may improve accuracy of pain quantification at the pain analyzer circuit 230, while reduce the overall operational cost of a pain management system such as an ambulatory pain monitor.

[0096] In some examples, the operating mode control 242 may determine operating modes associated with different sensors further based on sensor sensitivity to physical activity. The second sensor circuit 220 may acquire data from the different sensors according to their respectively determined operating modes. For example, some sensors, such as heart sound sensor, are sensitive to physical activity and may be susceptible to motion artifacts and other interferences during high activity periods, and thus become less reliable for use

in pain quantification. The second sensor circuit **220** may withhold data acquisition from these sensors when a high activity level is detected at the first sensor circuit **420**. On the other hand, certain sensors, such as EMG sensor, may not require a high sampling rate during periods of low activity (e.g., during sleep), while some other sensors, such as PPG or galvanic skin response (GSR) sensor, are not sensitive to changes in physical activity level. The second sensor circuit **220**, in response to a low physical activity detected at the first sensor circuit **420**, may withhold data acquisition or set a lower data acquisition rate for the EMG sensor, and set a high sampling rate for the PPG sensor or the GSR sensor.

[0097] The data sensed at the second sensor circuit **220** according to the determined operating mode may be used to assess pain at the pain analyzer circuit **230**. In some examples, the extracted feature from the feature extractor circuit **421**, such as features of posture, gait, physical activity, balance, or range-of-motion, may also be used to assess pain and generate a pain score at the pain analyzer circuit **230**.

[0098] FIG. 5 illustrates, by way of example and not limitation, a method **500** for managing pain of a patient. The method **500** may be implemented in a medical system, such as the pain management system **200** or **300**. In an example, at least a portion of the method **500** may be executed by a neuromodulator device (IND) such as the implantable neuromodulator **310**. In an example, at least a portion of the method **500** may be executed by an external programmer or remote server-based patient management system, such as the external system **320** that are communicatively coupled to the IND. The method **500** may be used to provide neuromodulation therapy to treat chronic pain or other disorders.

[0099] The method **500** begins at step **510**, where a first signal indicative of patient functional state may be sensed from the patient. The functional state signal may include a motor activity signal. By way of example and not limitation, motor activity signal may include patient posture, gait, balance, range-of-motion, or physical activity signals, among others. In some examples, the functional state signal may include a sleep state signal that contains information about sleep disturbance. Examples of the sleep state signals may include pain indicators during sleep, such as frequency or duration of sleep position switch, sleep incline, or other indicators of sleep quality or change of sleep pattern. Chronic pain patients may present with poor or unbalanced posture, abnormal gait pattern, restrained range-of-motion, or decreased intensity or duration of physical activities. Pain may also cause frequent sleep disturbance and poor sleep quality. Monitoring patient motor control or sleep disturbance may provide an objective assessment of pain, and may be used to improve pain therapy efficacy. The functional signals may be sensed using electrodes or ambulatory sensors, such as one or more motion sensors **411-415** associated with patient in different manners, as illustrated in FIG. 4.

[0100] At **520**, an operating mode of a second sensor circuit may be determined using the received first signal. The second sensor circuit, such as that illustrated in FIGS. 2 and 4, may be configured to sense a second signal different from the first signal sensed at **510** under a specified operating mode. The operating mode may include an activation or deactivation of sensor data acquisition by the second sensor circuit, or data sampling rate that the second sensor circuit uses for sampling the second signal. The operating mode may be determined using the control circuit **240** as

illustrated in FIG. 2. The first signal sensed at **510** may be compared to a specific criterion, such as a threshold or a value range, to determine whether to activate the data acquisition, time of data acquisition, or sampling rate of data acquisition of the second signal based on the comparison. Using the first sensor signal to trigger activation and set operating mode of the second sensor may offer several benefits in pain management, particularly in ambulatory pain monitor and quantification. It may reduce power consumption and optimize device memory usage. The functional state as indicated by the first sensed signal may indicate a precursor of pain episode, and activation of data acquisition and analysis of the second signal may generate a reliable confirmation of pain episode or worsening of pain. Additionally, the functional signal may be used to prescreen the second sensor such as to determine proper time for data acquisition to avoid interferences or noise and thus allowing for a higher quality data for use in pain assessment.

[0101] In an example, the operating mode of the second sensor circuit may be determined using one or more functional signal features of the first signal, such as extracted by the feature extractor circuit **421**. Examples of the functional signal features may include physical activity features such as activity intensity, activity duration, or a transition time between different types of activities; body position features during sitting, standing, or walking; motor control and kinematic features such as lumbar forward flexion, shoulder flexion, elbow flexion, rotation of arm and elbow joint, trunk-pelvis rotation, or a rate or a pattern of change in motion with respect to time or with respect to angular velocity; gait features such as time to peak velocity, step length, stride length, stride width, swing time, single limb support time, double limb stance, gait autonomy, cadence; or sleep state features such as sleep incline, sleep sidedness, frequency of sleep position switch, or other sleep quality or sleep disturbance metrics, among other signal features.

[0102] The extracted functional signal feature may be measured and trended over time. In some examples, the functional signal features may be measured during a specified time period of daytime or nighttime, or in a specific context such as when the patient is asleep. The functional signal feature trend may be compared to one or more thresholds or one or more value ranges to determine patient functional state. The operating mode of the second sensor circuit may be determined based on the patient functional state. In some examples, a physical activity pattern may be detected, such as via the pattern detector **423**, using measurements of the extracted feature over time. The detected physical activity pattern may be compared to a physical activity template representing a physical activity pattern under a known, controlled condition, such as a baseline pain-free condition. The operating mode of the second sensor circuit may be determined based on the comparison between the detected physical activity pattern and the physical activity template.

[0103] At **530**, a second signal different from the first signal may be sensed, such as via the second sensor circuit **220**, under the operating mode as determined at **520**. The second signal may include cardiac, pulmonary, neural, biochemical, or other physiological signals. Some of these signals may reveal characteristic signal properties in response to an onset, intensity, severity, duration, or patterns of pain. Examples of the second signal may include cardiac signals such as a heart rate signal, a pulse rate signal, a heart

rate variability signal, electrocardiograph (ECG) or intracardiac electrogram, cardiovascular pressure signal, or heart sounds signal, among others. The second signal may additionally or alternatively include a galvanic skin response (GSR) signal, an electrodermal activity (EDA) signal, a skin temperature signal, an electromyogram (EMG) signal, an electroencephalogram (EEG) signal, a magnetoencephalogram (MEG) signal, a hemodynamic signal such as a blood flow signal, a blood pressure signal, a blood perfusion signal, a photoplethysmography (PPG) signal, or a saliva production signal indicating the change of amount of saliva production, among others.

[0104] In an example, the operating mode of the second sensor circuit may be determined at 520 using a physical activity signal. Physical activity level may indicate presence or severity of pain. Patient in pain are generally less active, such that periods of activity are generally shorter and the activity intensity is generally lower. Therefore, a low physical activity level (in activity intensity or duration) may indicate a pain episode or precursor of pain has likely occurred, and a high physical activity level may indicate that the patient is not likely experiencing pain. In some examples, the physical activity may be measured during a specified time period of daytime or nighttime, or in a specific context such as when the patient is asleep. For example, a high physical activity level during a period of nighttime or during sleep may indicate onset of pain or undesirable pain treatment.

[0105] If the physical activity indicates that a pain episode or precursor of pain has likely occurred, then at 530, the data acquisition of the second signal, such as a cardiac, pulmonary, muscular, or neurological signal, may be initiated. Additionally, a higher data acquisition rate may be used in response to the detection of the low physical activity level, including one or more of a higher sampling rate, a higher digitization resolution, or a longer data acquisition time period, among others. This may preserve the information of patient response to pain, and thus improve the accuracy of pain quantification.

[0106] However, if the physical activity indicates that the patient is not likely experiencing pain, then at 530, the data acquisition of the second signal may be withheld, or the sensor circuit for sensing the second signal may be at least temporarily deactivated. The operating mode corresponding to the high physical activity level may additionally or alternatively include a lower data acquisition rate, including one or more of a lower sampling rate, a lower digitization resolution, or a shorter data acquisition time period, among others. When the physical activity or other functional signals indicate a low likelihood of pain, by reducing the activation time or acquiring data at lower data rate may save power and computing resources. Power and computing resources may be reserved for sensor data collection and analysis in case of an elevated likelihood of pain such as indicated by reduced activity level.

[0107] In some examples, at 520, operating modes associated with different sensors may be determined further based on a sensor's sensitivity to physical activity. Some sensors, such as heart sound sensor, are more sensitive to physical activity and susceptible to motion artifacts and other interferences during high activity periods, and thus become less reliable for use in pain quantification. On the other hand, certain sensors, such as EMG sensor, may not require a high sampling rate during periods of low activity

(e.g., during sleep), while some other sensors, such as PPG or galvanic skin response (GSR) sensor, are not sensitive to changes in physical activity level. At 530, sensor data may be acquired from different sensors according to their respectively determined operating modes. For example, when a high activity level is detected, the sensors that are more susceptible to interferences and noises are at least temporarily deactivated, the data acquisition from these sensors can be withheld. When a low physical activity detected, data acquisition of EMG may be withheld or set a lower data acquisition rate, and the PPG or the GSR signal may be acquired at a higher data acquisition rate.

[0108] At 540, a pain score may be generated using at least the second signal sensed under the determined operating mode, such as via the pain score generator 232. The pain score may be generated using signal metrics generated from the second signal sensed under the determined operating mode. The signal metrics may include statistical parameters, morphological parameters, or timing information such as a time interval between a first characteristic point in one signal and a second characteristic point in another signal. In an example, a composite signal metric may be generated using a combination of a plurality of the signal metrics respectively weighted by weight factors. The combination can be linear or nonlinear. The composite signal metric may be categorized as one of a number of degrees of pain by comparing the composite signal metric to one or more threshold values or range values, and a corresponding pain score may be assigned based on the comparison. In another example, the signal metrics may be compared to their respective threshold values or range values and a corresponding signal metric-specific pain score may be determined. A composite pain score may be generated using a linear or nonlinear fusion of the signal metric-specific pain scores each weighted by their respective weight factors. In some examples, the pain score may be computed using a subset of the signal metrics selected based on their temporal profile of pain response. Signal metrics with quick pain response (or a shorter transient state of response) may be selected to compute the pain score during a pain episode. Signal metrics with slow or delayed pain response (or a longer transient state of response before reaching a steady state) may be used to compute the pain score after an extended period following the onset of pain such as to allow the signal metrics to reach steady state of response. In some examples, patient demographic information such as patient age or gender may be used in computing the pain score. A higher pain threshold for the composite signal metric may be selected for male patients than for female patients. Additionally or alternatively, the respective weight factors may be determined based on patient demographic information. The weight factors for the signal metrics may be tuned to a lower value than the weight factors for the same signal metric in a female patient.

[0109] At 552, the pain score may be output to a user or to a process, such as via the output circuit as illustrated in FIG. 2. The pain score, including the composite pain score and optionally together with metric-specific pain scores, may be displayed on a display screen. Other information such as the functional signals and the signal metrics extracted from the functional signals may also be output for display or for further processing. In some examples, alerts, alarms, emergency calls, or other forms of warnings may be

generated to signal the system user about occurrence of a pain episode or aggravation of pain as indicated by the pain score.

[0110] The method **500** may include, at **554**, an additional step of delivering a pain therapy to the patient according to the pain score. The pain therapy may include electrostimulation therapy, such as spinal cord stimulation (SCS) via electrodes electrically coupled to the electrostimulator. The SCS may be in a form of stimulation pulses that are characterized by pulse amplitude, pulse width, stimulation frequency, duration, on-off cycle, waveform, among other stimulation parameters. Other electrostimulation therapy, such as one or a combination of DBS, FES, VNS, TENS, or PNS at various locations, may be delivered for pain management. The pain therapy may additionally or alternatively include a drug therapy such as delivered by using an intrathecal drug delivery pump.

[0111] In various examples, the pain therapy (such as in the form of electrostimulation or drug therapy) may be delivered in a closed-loop fashion. Therapy parameters, such as stimulation waveform parameters, stimulation electrode combination and fractionalization, drug dosage, may be adaptively adjusted based at least on the pain score. The pain-relief effect of the delivered pain therapy may be assessed based on the signal metrics such as the cardiovascular parameters, and the therapy may be adjusted to achieve desirable pain relief. The therapy adjustment may be executed continuously, periodically at specific time, duration, or frequency, or in a commanded mode upon receiving from a system user a command or confirmation of parameter adjustment. In an example, if the pain score exceeds the pain threshold (or falls within a specific range indicating an elevated pain), then the first electrostimulation may be delivered. Conversely, if the composite pain score falls below a respective threshold value (or falls within a specific range indicating no pain or mild pain), then a second pain therapy, such as second electrostimulation may be delivered. The first electrostimulation may differ from the second electrostimulation with respect to at least one of the stimulation energy, pulse amplitude, pulse width, stimulation frequency, duration, on-off cycle, pulse shape or waveform, electrostimulation pattern such as electrode configuration or energy fractionalization among active electrodes, among other stimulation parameters. In some examples, the responses of the signal metrics to pain therapy delivered at **544** may be used to gauge composite pain score computation such as by adjusting the weight factors. In an example, weight factors may be determined and adjusted via the weight generator **322** as illustrated in FIG. 3, to be proportional to signal metric's sensitivity to pain.

[0112] FIG. 6 illustrates generally a block diagram of an example machine **600** upon which any one or more of the techniques (e.g., methodologies) discussed herein may perform. Portions of this description may apply to the computing framework of various portions of the LCP device, the IMD, or the external programmer.

[0113] In alternative embodiments, the machine **600** may operate as a standalone device or may be connected (e.g., networked) to other machines. In a networked deployment, the machine **600** may operate in the capacity of a server machine, a client machine, or both in server-client network environments. In an example, the machine **600** may act as a peer machine in peer-to-peer (P2P) (or other distributed) network environment. The machine **600** may be a personal

computer (PC), a tablet PC, a set-top box (STB), a personal digital assistant (PDA), a mobile telephone, a web appliance, a network router, switch or bridge, or any machine capable of executing instructions (sequential or otherwise) that specify actions to be taken by that machine. Further, while only a single machine is illustrated, the term "machine" shall also be taken to include any collection of machines that individually or jointly execute a set (or multiple sets) of instructions to perform any one or more of the methodologies discussed herein, such as cloud computing, software as a service (SaaS), other computer cluster configurations.

[0114] Examples, as described herein, may include, or may operate by, logic or a number of components, or mechanisms. Circuit sets are a collection of circuits implemented in tangible entities that include hardware (e.g., simple circuits, gates, logic, etc.). Circuit set membership may be flexible over time and underlying hardware variability. Circuit sets include members that may, alone or in combination, perform specific operations when operating. In an example, hardware of the circuit set may be immutably designed to carry out a specific operation (e.g., hardwired). In an example, the hardware of the circuit set may include variably connected physical components (e.g., execution units, transistors, simple circuits, etc.) including a computer readable medium physically modified (e.g., magnetically, electrically, moveable placement of invariant massed particles, etc.) to encode instructions of the specific operation. In connecting the physical components, the underlying electrical properties of a hardware constituent are changed, for example, from an insulator to a conductor or vice versa. The instructions enable embedded hardware (e.g., the execution units or a loading mechanism) to create members of the circuit set in hardware via the variable connections to carry out portions of the specific operation when in operation. Accordingly, the computer readable medium is communicatively coupled to the other components of the circuit set member when the device is operating. In an example, any of the physical components may be used in more than one member of more than one circuit set. For example, under operation, execution units may be used in a first circuit of a first circuit set at one point in time and reused by a second circuit in the first circuit set, or by a third circuit in a second circuit set at a different time.

[0115] Machine (e.g., computer system) **600** may include a hardware processor **602** (e.g., a central processing unit (CPU), a graphics processing unit (GPU), a hardware processor core, or any combination thereof), a main memory **604** and a static memory **606**, some or all of which may communicate with each other via an interlink (e.g., bus) **608**. The machine **600** may further include a display unit **610** (e.g., a raster display, vector display, holographic display, etc.), an alphanumeric input device **612** (e.g., a keyboard), and a user interface (UI) navigation device **614** (e.g., a mouse). In an example, the display unit **610**, input device **612** and UI navigation device **614** may be a touch screen display. The machine **600** may additionally include a storage device (e.g., drive unit) **616**, a signal generation device **618** (e.g., a speaker), a network interface device **620**, and one or more sensors **621**, such as a global positioning system (GPS) sensor, compass, accelerometer, or other sensor. The machine **600** may include an output controller **628**, such as a serial (e.g., universal serial bus (USB), parallel, or other wired or wireless (e.g., infrared (IR), near field communi-

ation (NFC), etc.) connection to communicate or control one or more peripheral devices (e.g., a printer, card reader, etc.).

[0116] The storage device 616 may include a machine readable medium 622 on which is stored one or more sets of data structures or instructions 624 (e.g., software) embodying or utilized by any one or more of the techniques or functions described herein. The instructions 624 may also reside, completely or at least partially, within the main memory 604, within static memory 606, or within the hardware processor 602 during execution thereof by the machine 600. In an example, one or any combination of the hardware processor 602, the main memory 604, the static memory 606, or the storage device 616 may constitute machine readable media.

[0117] While the machine readable medium 622 is illustrated as a single medium, the term “machine readable medium” may include a single medium or multiple media (e.g., a centralized or distributed database, and/or associated caches and servers) configured to store the one or more instructions 624.

[0118] The term “machine readable medium” may include any medium that is capable of storing, encoding, or carrying instructions for execution by the machine 600 and that cause the machine 600 to perform any one or more of the techniques of the present disclosure, or that is capable of storing, encoding or carrying data structures used by or associated with such instructions. Non-limiting machine readable medium examples may include solid-state memories, and optical and magnetic media. In an example, a massed machine readable medium comprises a machine readable medium with a plurality of particles having invariant (e.g., rest) mass. Accordingly, massed machine-readable media are not transitory propagating signals. Specific examples of massed machine readable media may include: non-volatile memory, such as semiconductor memory devices (e.g., Electrically Programmable Read-Only Memory (EPROM), Electrically Erasable Programmable Read-Only Memory (EEPROM)) and flash memory devices; magnetic disks, such as internal hard disks and removable disks; magneto-optical disks; and CD-ROM and DVD-ROM disks.

[0119] The instructions 624 may further be transmitted or received over a communications network 626 using a transmission medium via the network interface device 620 utilizing any one of a number of transfer protocols (e.g., frame relay, internet protocol (IP), transmission control protocol (TCP), user datagram protocol (UDP), hypertext transfer protocol (HTTP), etc.). Example communication networks may include a local area network (LAN), a wide area network (WAN), a packet data network (e.g., the Internet), mobile telephone networks (e.g., cellular networks), Plain Old Telephone (POTS) networks, and wireless data networks (e.g., Institute of Electrical and Electronics Engineers (IEEE) 802.11 family of standards known as WiFi®, IEEE 802.16 family of standards known as WiMax®, IEEE 802.15.4 family of standards, peer-to-peer (P2P) networks, among others. In an example, the network interface device 620 may include one or more physical jacks (e.g., Ethernet, coaxial, or phone jacks) or one or more antennas to connect to the communications network 626. In an example, the network interface device 620 may include a plurality of antennas to wirelessly communicate using at least one of single-input multiple-output (SIMO), multiple-input multiple-output (MIMO), or multiple-input single-output

(MISO) techniques. The term “transmission medium” shall be taken to include any intangible medium that is capable of storing, encoding or carrying instructions for execution by the machine 600, and includes digital or analog communications signals or other intangible medium to facilitate communication of such software.

[0120] Various embodiments are illustrated in the figures above. One or more features from one or more of these embodiments may be combined to form other embodiments.

[0121] The method examples described herein can be machine or computer-implemented at least in part. Some examples may include a computer-readable medium or machine-readable medium encoded with instructions operable to configure an electronic device or system to perform methods as described in the above examples. An implementation of such methods may include code, such as micro-code, assembly language code, a higher-level language code, or the like. Such code may include computer readable instructions for performing various methods. The code can form portions of computer program products. Further, the code can be tangibly stored on one or more volatile or non-volatile computer-readable media during execution or at other times.

[0122] The above detailed description is intended to be illustrative, and not restrictive. The scope of the disclosure should, therefore, be determined with references to the appended claims, along with the full scope of equivalents to which such claims are entitled.

What is claimed is:

1. A system for managing pain of a patient, the system comprising:
  - a first sensor circuit configured to sense from the patient a first signal indicative of a functional state of the patient;
  - a second sensor circuit configured to sense from the patient a second signal different from the first signal; and
  - a controller circuit configured to:
    - determine an operating mode of the second sensor circuit using the sensed first signal;
    - trigger the second sensor circuit to sense the second signal under the determined operating mode;
    - generate a pain score using at least the second signal sensed under the determined operating mode; and
    - output the pain score to a user or a process.
2. The system of claim 1, further comprising an electrostimulator coupled to the controller circuit and configured to generate electrostimulation energy to treat pain,
  - wherein the controller circuit is further configured to control the electrostimulator to deliver a pain therapy and to control the electrostimulation energy generated by the electrostimulator according to the pain score.
3. The system of claim 2, wherein the electrostimulator is further configured to deliver at least one of:
  - a spinal cord stimulation;
  - a brain stimulation; or
  - a peripheral nerve stimulation.

4. The system of claim 1, wherein the first sensor circuit is coupled to at least one ambulatory sensor to sense the first signal, the ambulatory sensor including at least one of:

- an accelerometer;
- a gyroscope;
- a magnetometer;
- a strain gauge; or
- a global positioning system sensor.

5. The system of claim 1, wherein the first signal includes a physical activity signal, and the controller circuit is further configured to:

- trigger the second sensor circuit to sense the second signal under a first operating mode if the physical activity signal falls below an activity threshold; and
- trigger the second sensor circuit to sense the second signal under a second operating mode different from the first operating mode if the physical activity signal exceeds the activity threshold.

6. The system of claim 1, wherein the first signal includes a physical activity signal, and the controller circuit is further configured to:

- trigger the second sensor circuit to sense the second signal under a first operating mode if the physical activity signal corresponds to a physical activity template indicative of a physical activity pattern when the patient is free of pain; and
- trigger the second sensor circuit to sense the second signal under a second operating mode different from the first operating mode if the physical activity signal fails to correspond to the physical activity template.

7. The system of claim 1, wherein the first signal includes at least one of:

- a posture signal;
- a balance signal; or
- a range-of-motion signal.

8. The system of claim 1, wherein the controller circuit is further configured to determine the operating mode of the second sensor circuit including initiating data acquisition if the sensed first signal satisfies a condition.

9. The system of claim 1, wherein the controller circuit is further configured to determine the operating mode of the second sensor circuit including adjusting data acquisition rate if the sensed first signal satisfies a condition.

10. The system of claim 1, wherein the controller circuit is further configured to:

- generate one or more signal metrics from the sensed second signal under the determined operating mode; and
- generate the pain score using the generated one or more signal metrics respectively weighted by weight factors.

11. The system of claim 1, wherein the controller circuit is further configured to generate the pain score further using the sensed first signal.

12. The system of claim 2, further comprising an implantable neuromodulator device that includes one or more of the first sensor circuit, the second sensor circuit, the controller circuit, or the electrostimulator.

13. A method for managing pain of a patient using an implantable neuromodulator device, the method comprising: sensing a first signal indicative of a functional state of the patient via a first sensor circuit; determining an operating mode of a second sensor circuit using the sensed first signal; sensing a second signal via the second sensor circuit under the determined operating mode, the second signal different from the first signal; generating a pain score using at least the second signal sensed under the determined operating mode; and outputting the pain score to a user or a process.

14. The method of claim 13, further comprising delivering a pain therapy via the implantable neuromodulator device, the pain therapy including electrostimulation energy determined according to the pain score.

15. The method of claim 13, wherein determining the operating mode of the second sensor circuit includes initiating data acquisition if the sensed first signal satisfies a condition.

16. The method of claim 14, wherein determining the operating mode of the second sensor circuit includes adjusting data acquisition rate if the sensed first signal satisfies a condition.

17. The method of claim 14, wherein the first signal includes a physical activity signal, and wherein determining the operating mode of the second sensor circuit includes:

- comparing the sensed physical activity signal to an activity threshold or to an activity template;
- initiating data acquisition of the second signal or acquiring the second signal at a first data acquisition rate if the comparison satisfies a first condition; and
- withholding data acquisition of the second signal or acquiring the second signal at a second, lower data acquisition rate than the first data acquisition rate if the comparison satisfies a second condition indicating a higher physical activity level.

18. The method of claim 13, wherein the first signal includes at least one of:

- a posture signal;
- a balance signal; or
- a range-of-motion signal.

19. The method of claim 13, wherein the second signal includes at least one of:

- a cardiac electrical activity signal;
- an electromyography signal;
- a photoplethysmography signal;
- a galvanic skin response signal;
- an electroencephalogram signal; or
- a hemodynamic signal.

20. The method of claim 13, further comprising generating one or more signal metrics from the sensed second signal under the determined operating mode, wherein generating the pain score includes using the generated one or more signal metrics respectively weighted by weight factors.

\* \* \* \* \*

专利名称(译)	基于传感器的疼痛管理系统和方法		
公开(公告)号	<a href="#">US20190022397A1</a>	公开(公告)日	2019-01-24
申请号	US16/034304	申请日	2018-07-12
[标]申请(专利权)人(译)	波士顿科学神经调制公司		
申请(专利权)人(译)	波士顿科学神经调节CORPORATION		
当前申请(专利权)人(译)	波士顿科学神经调节CORPORATION		
[标]发明人	SRIVASTAVA KYLE HARISH THAKUR PRAMODSINGH HIRASINGH HUYNH DAT THANH CLARK BRYAN ALLEN GU JIANWEN		
发明人	SRIVASTAVA, KYLE HARISH THAKUR, PRAMODSINGH HIRASINGH HUYNH, DAT THANH CLARK, BRYAN ALLEN GU, JIANWEN		
IPC分类号	A61N1/36 A61B5/00 A61B5/11 A61B5/0402 A61B5/0488 A61B5/0476 A61B5/053 A61B5/02 A61B5/024		
CPC分类号	A61B5/1112 A61B2562/0223 A61B5/1116 A61B5/1121 A61B5/0402 A61B5/0488 A61B5/0476 A61B5/0533 A61B5/02028 A61B5/02416 A61N1/36071 A61B2562/0219 A61B2562/0261 A61B5/4824 A61N1/36139 A61B5/1118 A61B5/01 A61B5/021 A61B5/024 A61B5/0816 A61B5/4806 A61N1/0529 A61N1/0551 A61N1/36053 A61N1/36057 A61N1/36062 A61B5/112		
优先权	62/533789 2017-07-18 US		
外部链接	<a href="#">Espacenet</a> <a href="#">USPTO</a>		

摘要(译)

该文件尤其讨论了用于管理受试者疼痛的系统和方法。一种系统包括：第一传感器电路，用于感测指示对象的功能状态的第一信号；第二传感器电路，用于感测与第一信号不同的第二信号；以及控制器电路。控制器电路可以根据感测到的第一信号确定第二传感器电路的操作模式，触发第二传感器电路以在确定的操作模式下感测第二信号，并且至少使用在第二信号下感测到的第二信号产生疼痛评分。确定的运行模式。疼痛评分可以输出给患者或用于疼痛治疗的闭环控制。

