



US 20180008155A1

(19) **United States**

(12) **Patent Application Publication**  
**Melker et al.**

(10) **Pub. No.: US 2018/0008155 A1**  
(43) **Pub. Date: Jan. 11, 2018**

(54) **METHODS AND DEVICES FOR CENTRAL  
PHOTOPLETHYSMOGRAPHIC  
MONITORING**

**Publication Classification**

(71) Applicant: **University of Florida Research  
Foundation, Inc.**, Gainesville, FL (US)

(51) **Int. Cl.**  
*A61B 5/0295* (2006.01)  
*A61B 5/02* (2006.01)  
*A61B 5/1455* (2006.01)  
*A61M 16/06* (2006.01)  
*A61B 5/00* (2006.01)  
*A61B 5/026* (2006.01)  
*A61B 5/024* (2006.01)

(72) Inventors: **Richard J. Melker**, Gainesville, FL  
(US); **Neil Euliano**, Gainesville, FL  
(US); **Brian Fuerhlein**, Gainesville, FL  
(US)

(52) **U.S. Cl.**  
CPC ..... *A61B 5/0295* (2013.01); *A61B 5/6817*  
(2013.01); *A61B 5/02* (2013.01); *A61B 5/0261*  
(2013.01); *A61B 5/14552* (2013.01); *A61M*  
*16/06* (2013.01); *A61B 5/6838* (2013.01);  
*A61B 5/6819* (2013.01); *A61M 16/0627*  
(2014.02); *A61B 5/6815* (2013.01); *A61B*  
*5/6803* (2013.01); *A61B 5/02416* (2013.01);  
*A61M 16/0683* (2013.01); *A61M 2230/205*  
(2013.01); *A61M 2230/432* (2013.01)

(21) Appl. No.: **15/651,697**

(22) Filed: **Jul. 17, 2017**

**Related U.S. Application Data**

(60) Division of application No. 14/171,154, filed on Feb.  
3, 2014, which is a continuation of application No.  
12/377,706, filed on Feb. 23, 2009, now Pat. No.  
8,641,635, which is a continuation-in-part of appli-  
cation No. PCT/US05/28355, filed on Aug. 10, 2005.

(60) Provisional application No. 60/600,548, filed on Aug.  
11, 2004.

**Foreign Application Priority Data**

Aug. 10, 2005 (US) ..... PCT/US05/28355

(57) **ABSTRACT**

Provided according to embodiments of the present invention are methods of monitoring individuals that include securing a photoplethysmography probe to at least one of a pre-auricular region and a post-auricular region of the individual and obtaining photoplethysmography signals from the photoplethysmography probe. Photoplethysmography probes and helmets related to such methods are also described herein.

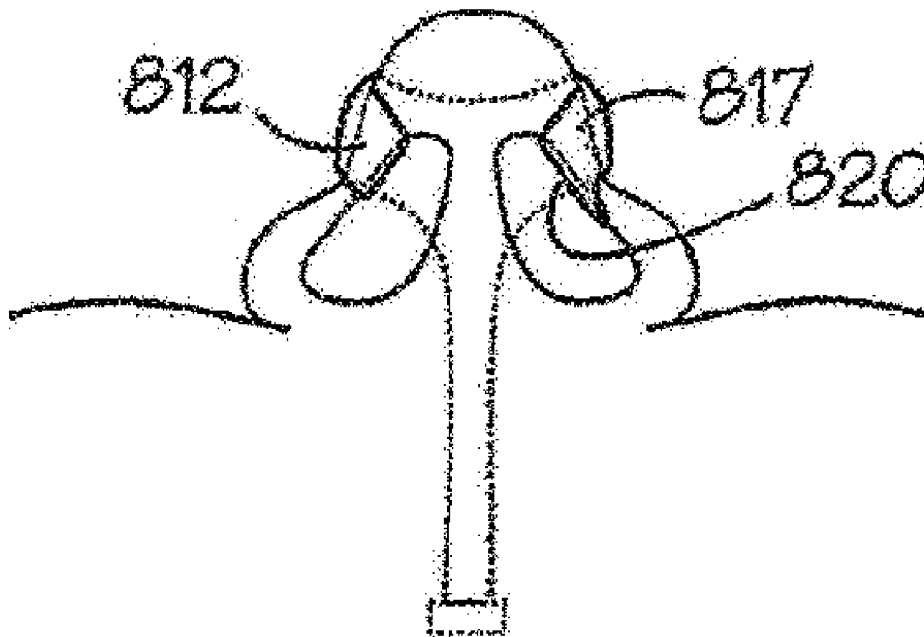

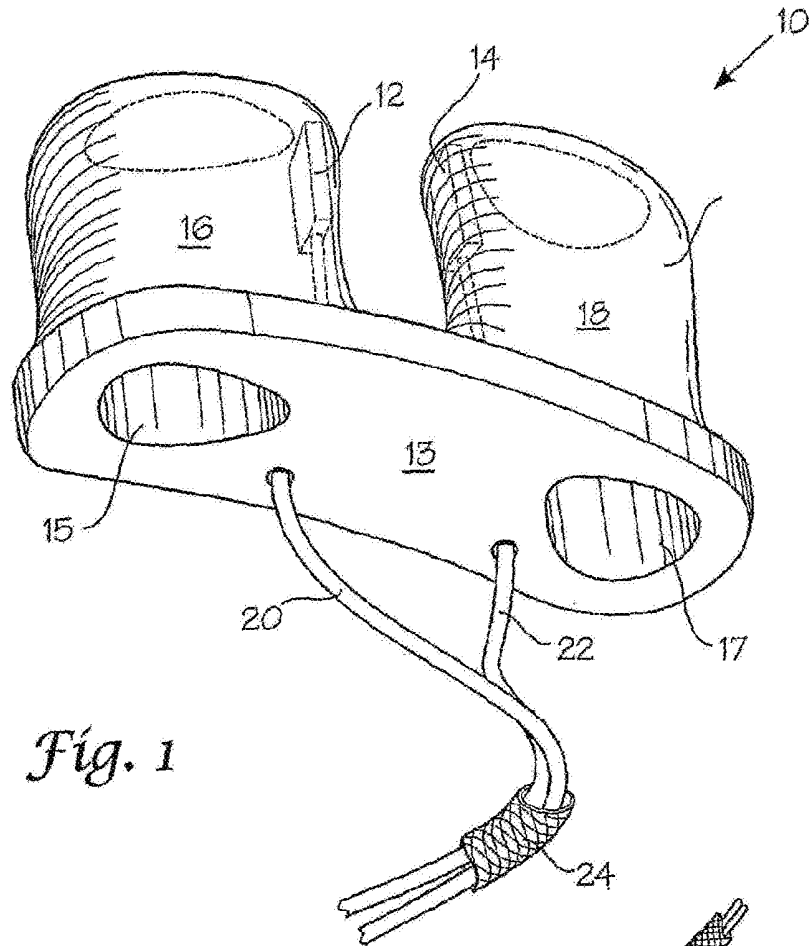

Fig. 1

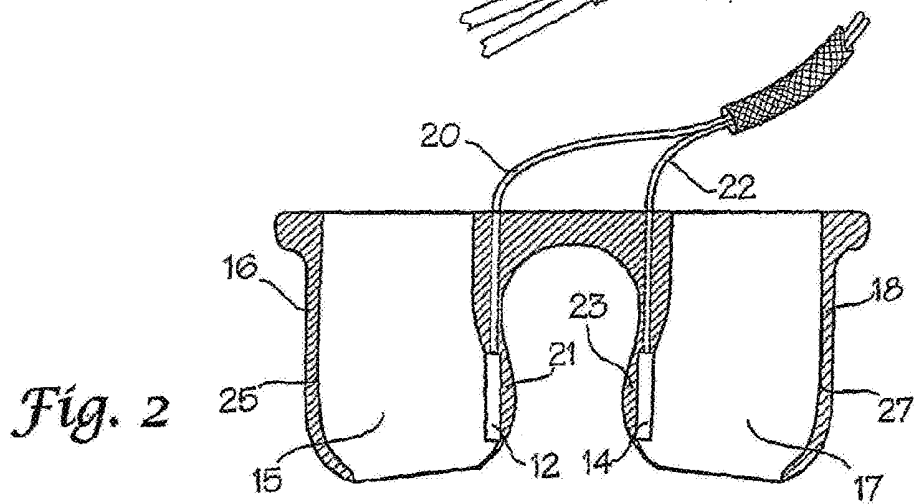
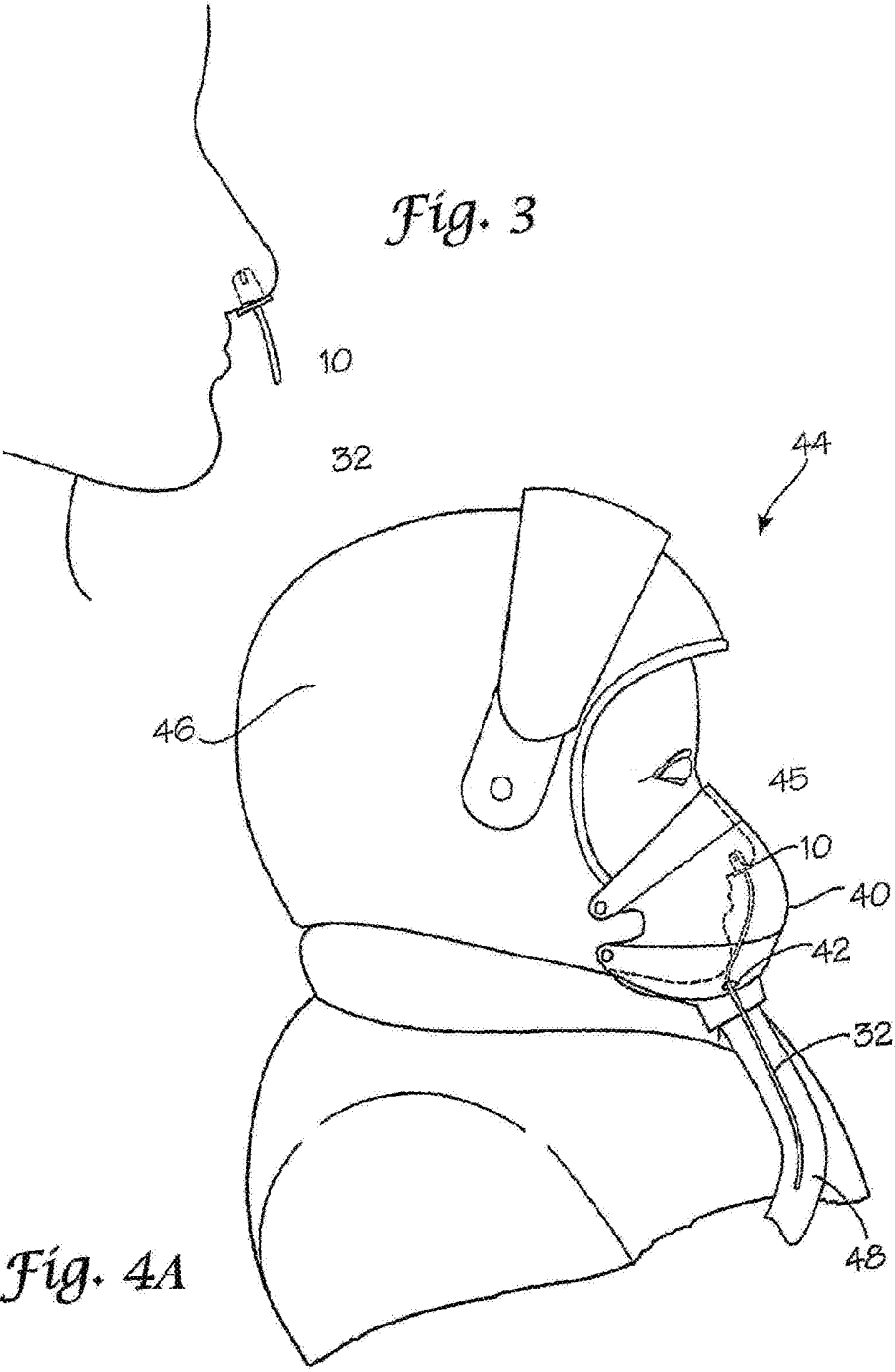

Fig. 2



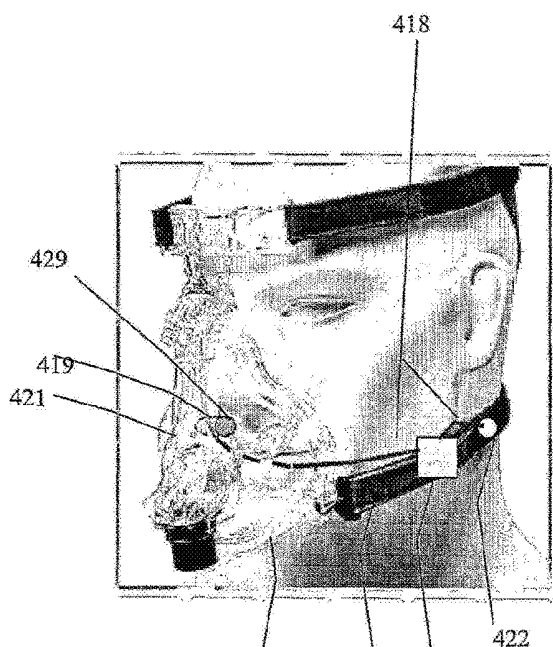

FIG. 4B

410

411

420

422

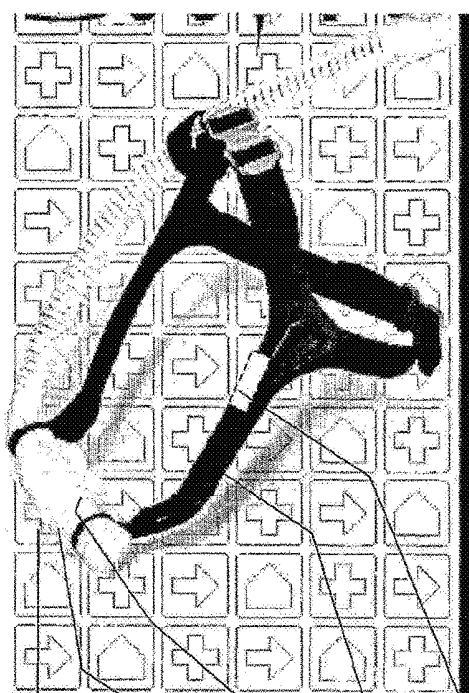

FIG. 4C

412

423

425

413

427

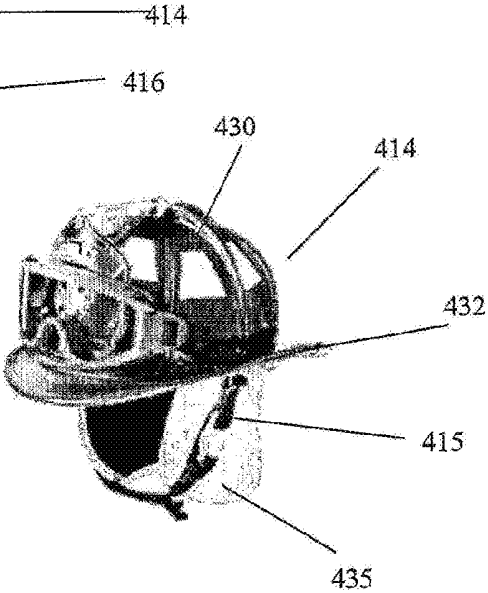
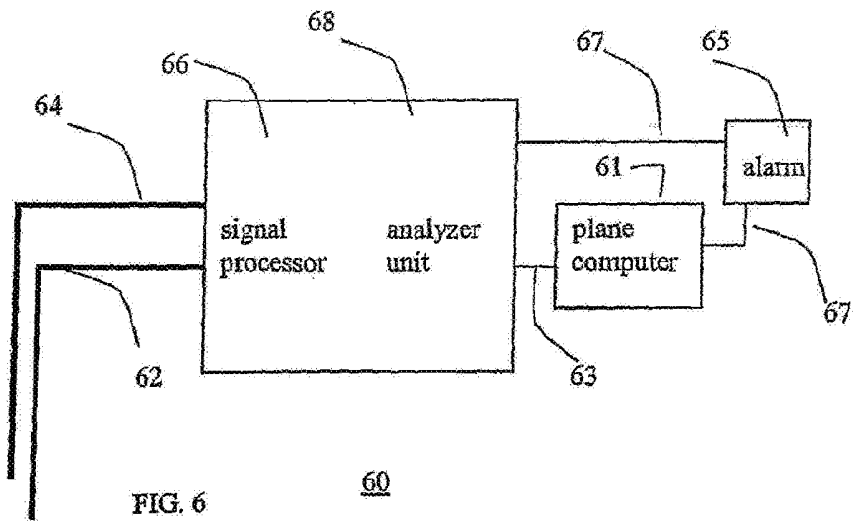
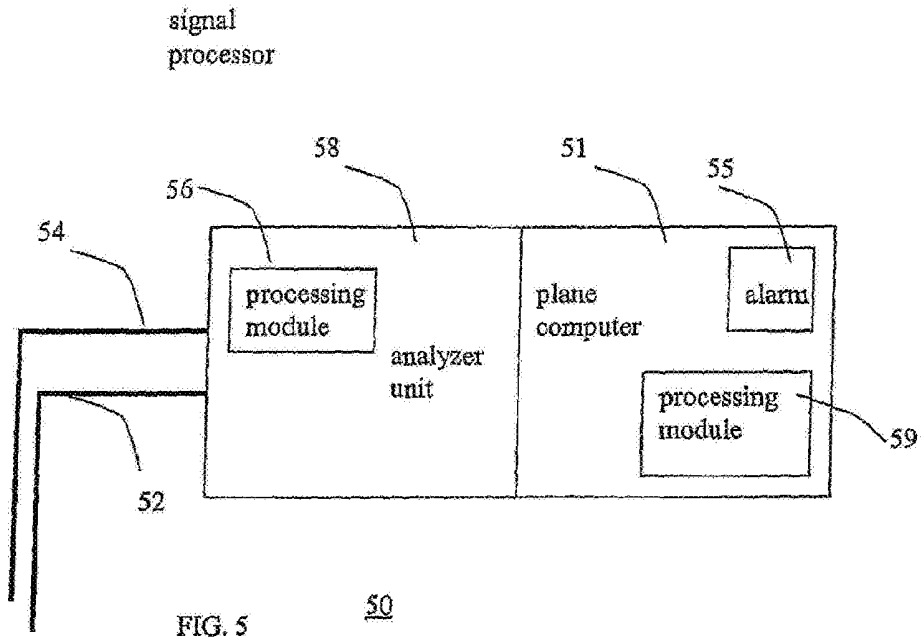
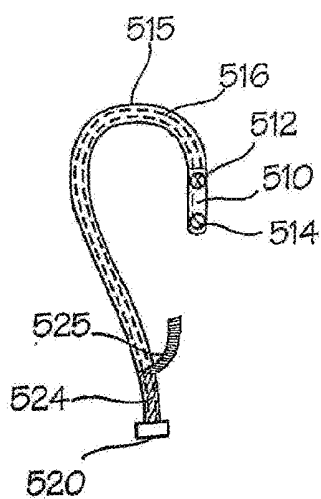
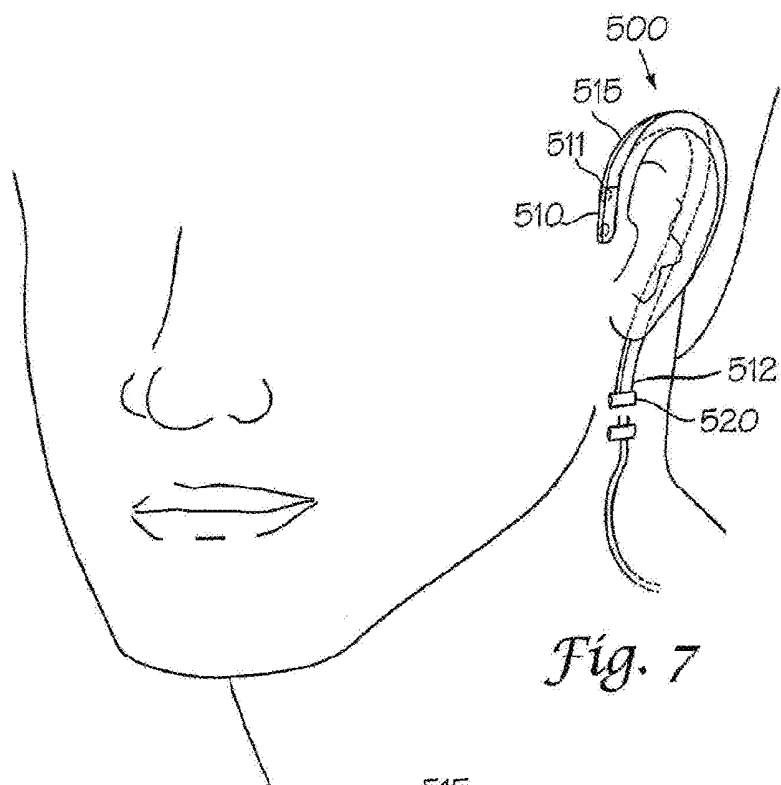

FIG. 4D

FIG. 4E





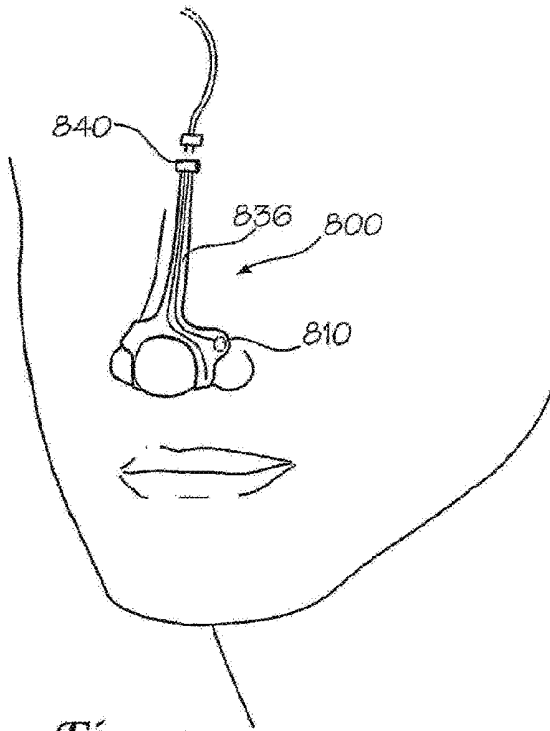

Fig. 9

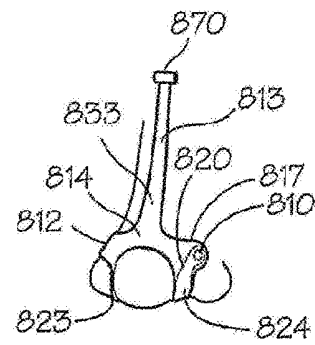

Fig. 10

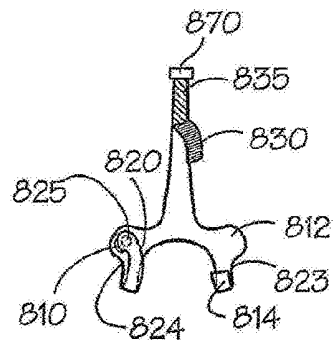

Fig. 11

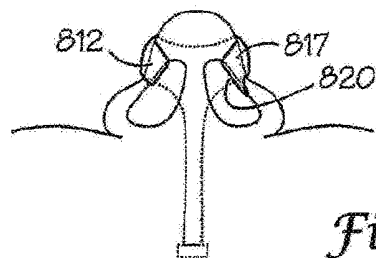

Fig. 12

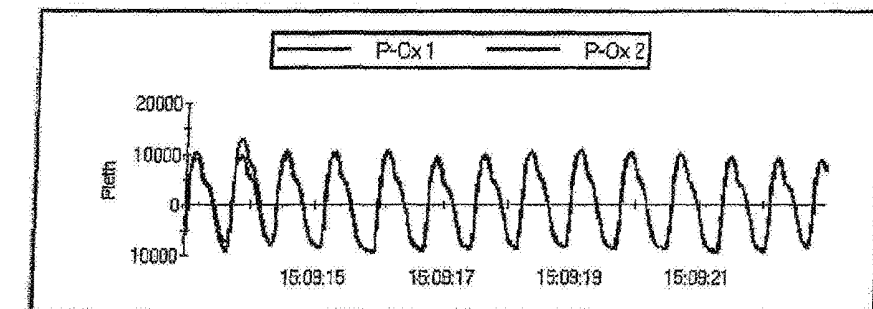

Fig. 13A

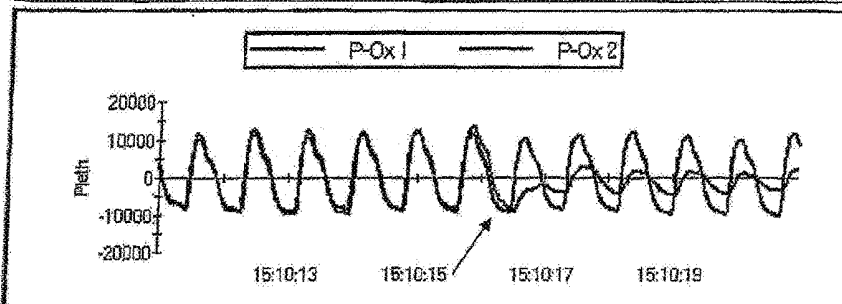

Fig. 13B

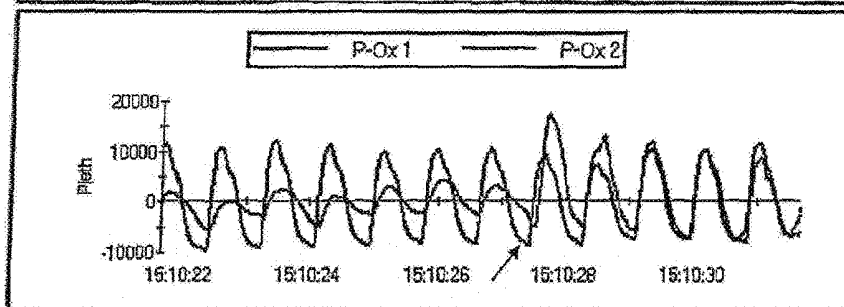

Fig. 13C

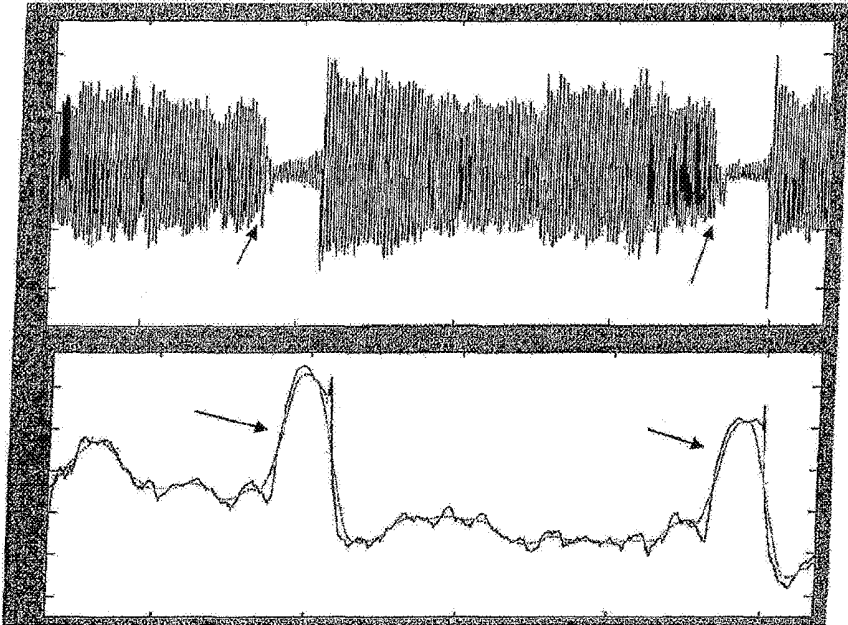

Fig. 14A

Fig. 14B

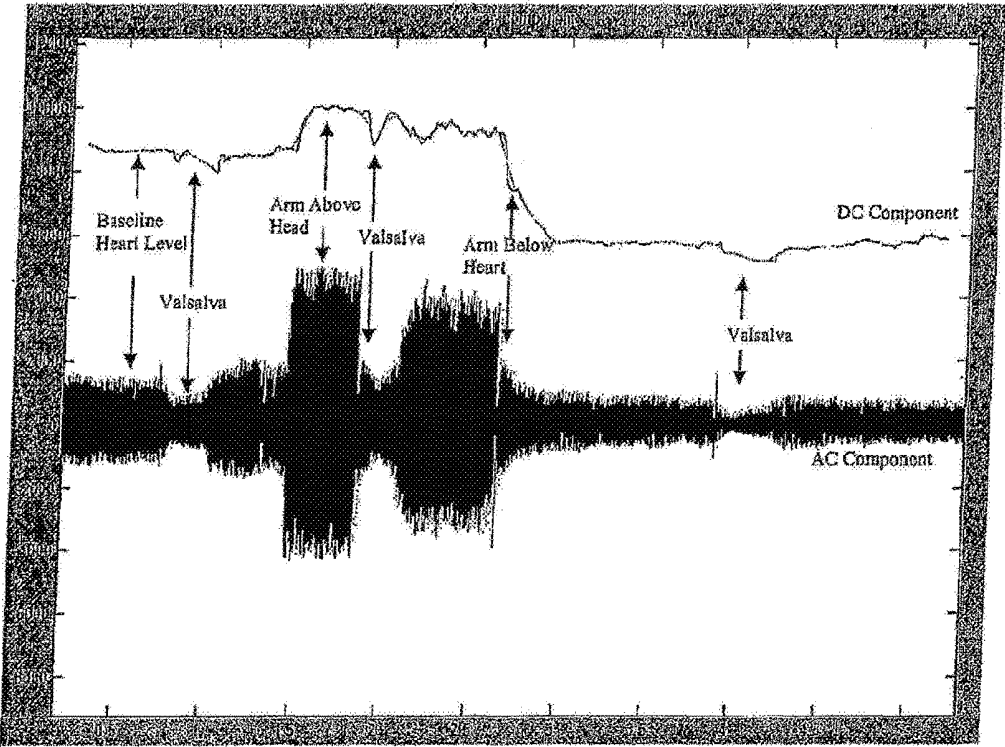

FIG. 15

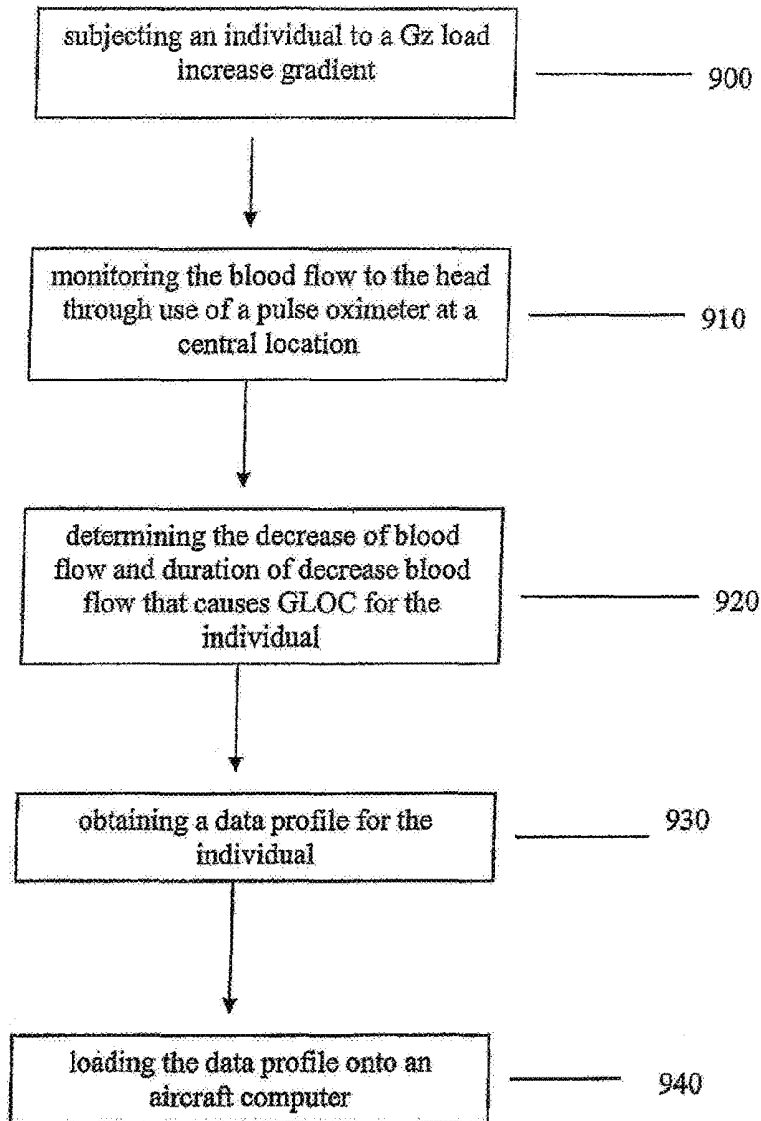

FIG. 16

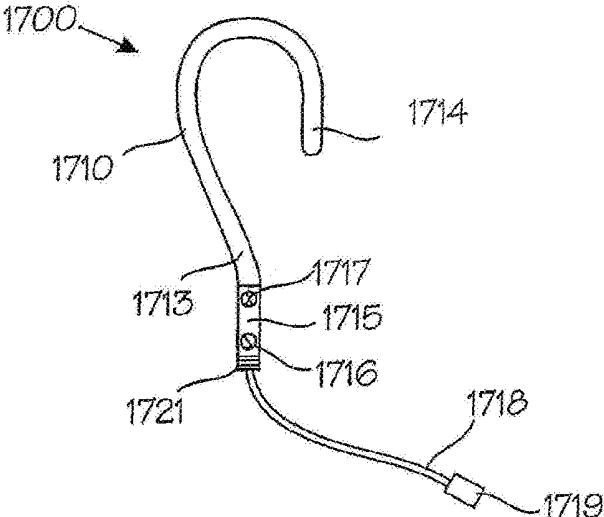
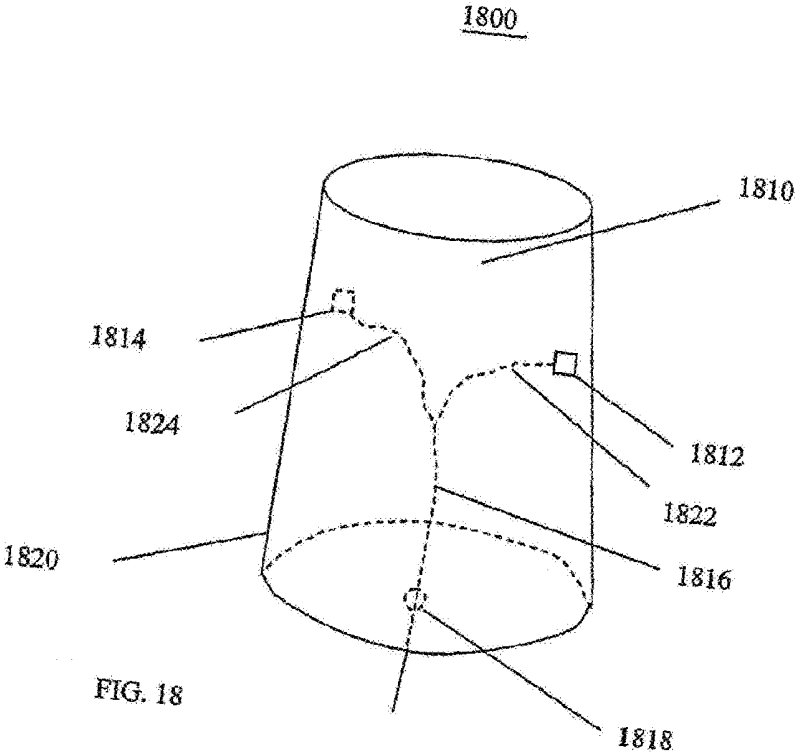

Fig. 17



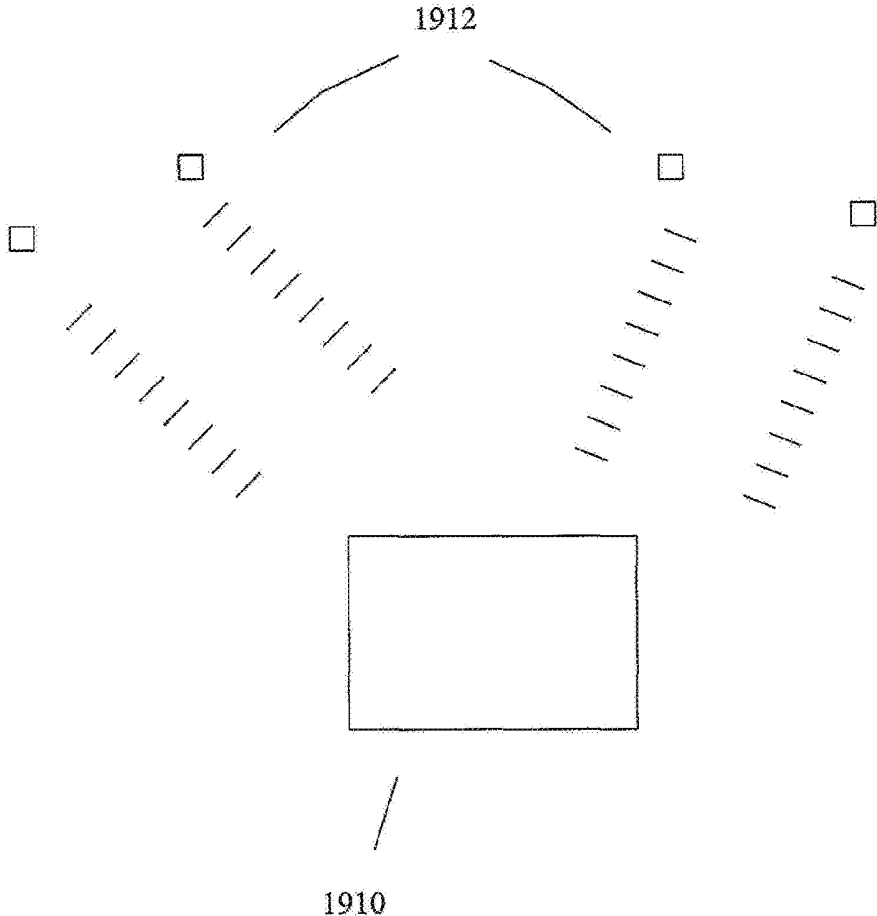

FIG. 19

## METHODS AND DEVICES FOR CENTRAL PHOTOPLETHYSMOGRAPHIC MONITORING

### CROSS-REFERENCE TO RELATED APPLICATIONS

[0001] This application is a continuation of U.S. patent application Ser. No. 12/377,706, filed Feb. 17, 2009, which is a continuation in part of International Application No. PCT/US05/28355 filed Aug. 10, 2005, whose teaching are incorporated herein by reference, and which claims priority to U.S. Provisional Application No. 60/600,548, filed Aug. 11, 2004.

### BACKGROUND OF THE INVENTION

[0002] Gravity-induced loss of consciousness (“GLOC”) is a prototypical example of a phenomenon of reduced cerebral blood flow that occurs when someone is subjected to substantially increased gravitational loads (+Gz) for a sustained period. High-performance aircraft, such as fighters, allow maneuvers that generate +Gz that exceed the limits of the human body. This predisposes to GLOC and a serious degrading of physiological and cognitive performance. GLOC is one of the primary physiological threats to pilots and crews of high-performance aircraft. Since the mid 1980s, one branch of the US military, the United States Air Force, has lost 29 aircraft and 22 pilots to GLOC. (The Effect of Negative Gz Recovery from GLOC on Cerebral Oximetry, Broughton, presentation at USAF School of Aerospace Medicine, Brooks AFB, Texas (2003).) Similar loss rates can be expected for the other services flying high performance aircraft. In addition to the loss of life, the cost of training and lost aircraft is staggering.

[0003] Almost loss of consciousness (ALOC) is even more common than GLOC. Symptoms include euphoria, apathy, displacement, depersonalization, poor response to auditory stimuli, immediate memory difficulties, sensory abnormalities, motor abnormalities, confusion, and dream-like state without loss of consciousness, which are considered precursors of GLOC, which is defined as “A state of altered perception wherein one’s awareness of reality is absent as a result of sudden, critical reduction of critical blood circulation caused by increased G forces”. (Morrisette K L, McGowan D G. Further support for the concept of a G-LOC syndrome: a survey of military high-performance aviators. *Aviat Space Environ Med.* 2000; 71:496-500.; Burton RR, G-Induced Loss of Consciousness: Definition, History, Current Status. *Aviat Space Environ Med.* 1988; 59:2-5.)

[0004] Some methods have been developed to increase G-level tolerances, including centrifuge training, weight training, the anti-G suit, positive pressure breathing, anti-G straining maneuvers and postural modification in the cockpit. The current capabilities of trained individuals to maintain clear vision during sustained exposures to +9 Gz, an increase in protected +Gz tolerance of about +4 Gz over World War II fighter pilots, is largely a result of combined use of a G suit and self-protective straining maneuvers such as the M-1, L-1 and pressure breathing, all of which are variants of the Valsalva maneuver developed in the 1940s. (*G-induced Loss of Consciousness and its Prevention*, Earl Wood, (1988) Mayo Clinic, Rochester, Minn.) However, despite such training, a review of ten fatal crashes attributed

to GLOC shows that such measures fall short of addressing the problem. Id. The Wood review notes that the likely causes of such failures were: (1) increased capability of jet powered fighters to sustain, with minimal pilot effort, accelerations in the 7-10+Gz range for periods longer than the symptom-free 3-8 second cerebral ischemic anoxic period which precedes GLOC, (2) an improperly performed Valsalva-type straining maneuver, and (3) development of a hypotensive vasovagal type reaction.

[0005] The inventors believe that currently used techniques do not adequately address the detection of reduced cerebral blood flow. For example, the problem of GLOC (which for the purposes of this document pertains to both ALOC and GLOC) puts the burden on the pilot to realize when he/she is about to sustain GLOC. Further, reduced cerebral blood flow is a serious medical condition which can lead to irreversible brain injury. At present there are no simple and reliable technologies for measuring cerebral blood flow noninvasively. For example, decreased cerebral perfusion may occur during surgery, trauma, sleep disorders, cerebral vascular insufficiency (eg. Ischemic stroke), hypotension from a wide variety of causes or during ventilatory management

### SUMMARY OF THE INVENTION

[0006] The subject invention pertains to methods, devices and systems of obtaining plethysmography readings and utilizing plethysmography to identify reduced cerebral blood flow both when pilots are about to experience GLOC and for training pilots to recognize signs and symptoms of impending GLOC. And in the medical environment where it can serve as an early warning system of impending cerebral ischemia and as a monitor to determine the presence and degree of cerebral flow. Clinicians can be warned that the cerebral blood flow is decreasing and/or the system can be integrated into closed loop system to optimize therapies that can improve flow to the brain (such as ventilator management techniques, fluid resuscitation or drug delivery systems). Furthermore, in other embodiments, the invention pertains to methods and devices designed to warn a pilot that he/she is about to sustain GLOC and/or automatically averting catastrophic damage or injuries by directing the plane to take predetermined corrective actions. In addition to airlight applications, the methods and devices herein can be used to monitor workers whose jobs require high stress situations or harsh environments, such as emergency response teams. Finally, the subject invention allows measurements made during training in centrifuges and aircraft to be displayed for real-time feedback to teach the pilot to optimize GLOC prevention maneuvers and to be stored and used to provide an individual pilot’s plethysmographic data for developing GLOC “profiles” which can be programmed into flight systems to determine when an individual pilot is entering the early stages of GLOC based on previously collected data.

[0007] According to other aspects, the subject invention pertains to novel pulse oximeter probes. The term “pulse oximeter probe” as used herein refers to probes that can be used for pulse oximetry determination of arterial blood oxygen saturation and/or used for plethysmography.

### BRIEF DESCRIPTION OF THE DRAWINGS

[0008] FIG. 1 shows a perspective view of a pulse oximeter/plethysmography probe designed for securement in the nose of the user.

[0009] FIG. 2 shows a side cross-sectional view of the embodiment shown in FIG. 1.

[0010] FIG. 3 shows a side view of a user having a pulse oximeter probe as shown in FIG. 1 inserted and secured in their nose.

[0011] FIGS. 4A-4E show mask and helmet embodiments having a probe associated therewith.

[0012] FIG. 4A shows a side view of a pilot wearing a mask with a probe. FIG. 4B shows a ventilation mask suitable for association of a probe. FIG. 4C shows a nasal mask. FIG. 4D shows a mask for emergency responders and helmet. FIG. 4E shows a helmet suitable for association with a probe.

[0013] FIG. 5 is a schematic of an embodiment of the subject invention that comprises an analyzer unit integrated with an aircraft computer.

[0014] FIG. 6 is a diagram showing a schematic of an embodiment of the subject invention comprising an analyzer unit operationally coupled to an aircraft computer.

[0015] FIG. 7 shows a perspective view of a pre-auricular reflectance probe embodiment of the subject invention.

[0016] FIG. 8 shows a side view of a pre-auricular reflectance probe embodiment of the subject invention.

[0017] FIG. 9 shows a perspective view of an alar pulse oximeter probe embodiment.

[0018] FIG. 10 shows a front perspective view of the alar pulse oximeter probe embodiment shown in FIG. 9.

[0019] FIG. 11 shows a rear perspective view of the alar pulse oximeter probe embodiment shown in FIG. 9.

[0020] FIG. 12 shows a bottom view of the alar pulse oximeter probe embodiment shown in FIG. 9.

[0021] FIG. 13A-C shows a plethysmograph obtained from the right and left cheek of an individual. FIG. 13A shows the right and left plethysmograph without depressing the carotid artery. FIG. 13B shows the right and left plethysmograph with pressing the right carotid artery.

[0022] FIG. 13C shows the right and left plethysmograph after releasing the right carotid artery.

[0023] FIG. 14A-B represents a plethysmograph from a pulse oximeter probe positioned on the cheek. The AC component (or cardiac component for purposes of this example) is provided in FIG. 14A and the DC offset (or non-cardiac component for purposes of this example) is provided in FIG. 14B. Pressing on the carotid diminishes blood flow, as seen in the AC component (see arrow). Conversely, the DC offset goes up when the carotid is depressed (see arrows).

[0024] FIG. 15 represents a plethysmograph obtained from the finger. The DC offset is plotted at the top and the AC component at the bottom.

[0025] FIG. 16 represents a diagram illustrating a method embodiment of the subject invention for obtaining a personalized data profile for an individual with information for determining whether individual is about to enter GLOC.

[0026] FIG. 17 represents a perspective view of a post-auricular probe embodiment.

[0027] FIG. 18 represents a perspective view of an ear canal probe embodiment for obtaining plethysmography readings from a user's ear canal.

[0028] FIG. 19 represents a remote monitoring station to monitor one or more subjects.

## DESCRIPTION OF THE ILLUSTRATED EMBODIMENTS OF THE INVENTION

[0029] Turning to FIG. 1, a nasal pulse oximeter probe 10 is shown designed for the comfortable placement in the nostrils of a human or non-human. The nasal probe 10 may be made of a wide array of materials, including, but not limited to, silicon, rubber, plastic or other polymer-based materials, or other suitable materials. Preferably, the nasal probe is comprised, at least in part, of materials (similar to hearing aid ear molds) that are soft and flexible as to allow proper comfort by the user, but possess enough rigidity to properly conform to the inner walls of the nose and provide frictional resistance to secure the probe in the user's nose. The nasal probe 10 comprises a first insert 16 having defined therein a channel 15 and a second insert 18 having defined therein a channel 17. Channels 15 and 17 are of a dimension to allow for the free-flowing passage of air as the user inhales and exhales in and out of the user's nose. Positioned in or on the medial wall of insert 16 is a light generating source, such as a light emitting diode (LED). A photodetector 14 is positioned on or in the medial region of insert 18. Wires 20 and 22 are connected to the light generating source 12 in photodetector 14, respectively. To assist in the management of wires 20 and 22, wires 20 and 22 may be secured together by fastener 24, such as a sleeve. Those skilled in the art will appreciate than any means for holding together wires may be used for this purpose, including, but not limited to, a clip, tie, ring, band, etc. Additionally, positioning the photodetector and LED on the same wall of the same insert such that the sensor functions in a reflectance mode is also contemplated. A nasal probe with a single insert (reflectance on either the alar wall on nasal septal wall) is contemplated as well. Additionally a nasal insert—transmissive with a flap/clip portion on the exterior of the nare is contemplated as well. Since reflective pulse-oximetry requires light to return to approximately the same location as it was transmitted, a variety of reflective surfaces could be envisioned in this scenario as well. For example, the transmitter and receiver could be co-located on one wall of the insert and the second insert could be made of a photo-reflective material or contain a reflective surface. It is also envisioned that the reflective material could be made to focus (like a lens) scattered light back at the photo detector to: a) increase signal to noise ratio, b) help reduce motion artifacts, or c) reduce the LED power requirements (thus allowing longer battery operating times). This same technique could be used in various other orientations such as the LED and photodiode on the external side of the nare of the nose and a simple reflective material on the inside of the nose (or vice versa). This technique could allow more comfortable and less obtrusive materials to be used in certain key locations. Further, if sensors are to be worn continuously, especially in an ambulatory environment, less conspicuous sensors would improve acceptance and compliance with wearing the devices.

[0030] In addition, the inventors do not intend to be limited to the type of probe that may be used. U.S. application Ser. Nos. 10/176,310; 10/751,308; and 10/749,471 disclose various probe embodiments that may be implemented for use in accord with the teachings herein. These applications also teach the functional and technical aspects of the LED and photodetector.

[0031] As used herein, the term "central source site" refers to a site above a user's neck, wherein information regarding

blood flow at such site correlates with blood flow to the user's brain. Examples of central source sites, include, but are not limited to, the tongue, lip, cheek, nasal nares, nasal septum, nasal alar, pre-auricular region, post-auricular region and ears.

[0032] FIG. 2 shows a cross-sectional side view of the nasal probe embodiment 10 shown in FIG. 1. The LED(s) 12 and photodetector 14 are positioned across from each other. To monitor oxygen saturation, two or more LEDs are typically required. For plethysmography, only one IR LED is needed. However, multiple LEDs are contemplated as well for increased reliability, or for reliable measurement of dyshemoglobin, carbon monoxide, other inhaled pollutants, or blood analytes such as glucose and electrolytes. In addition, various types of CO<sub>2</sub> sensors could be incorporated in the nasal probe. These sensors could include infrared spectroscopy, raman spectroscopy, colorimetry, and various nanotechnology sensors. The CO<sub>2</sub> sensor provides important ventilation information that could be used in hazardous material scenarios, ventilatory support, or sleep disorders. Further, without being limited to any specific mechanism or theory, it is the belief of the inventors that the plethysmogram will show signs of reduced blood flow to the head such as GLOC far earlier than changes in oxygen saturation. However, it is contemplated that the probes and methods of the subject invention may be designed and used to monitor both plethysmography and oxygen saturation of the user.

[0033] Insert 16 comprises a medial region 21 and a lateral region 25. Insert 18 also comprises a medial region 23 and a lateral region 27. The user's nasal septum would lie in the space defined by the medial regions 21, 23 of inserts 16, 18, respectively. Accordingly, the medial region represents that portion of the insert that contacts the user's nasal septum. The lateral region represents that portion of the insert that is proximate to the user's nares. Though the disclosed embodiment shows that the inserts completely define an inner channel, with the insert having a medial region and a lateral region, the insert may be fashioned to define less than the full circumference around an inner channel. Wires 20 and 22 are connected to the LED 12 and the photodetector 14, respectively.

[0034] FIG. 3 shows a side view of a person having the nasal probe embodiment 10 placed in their nostrils. Wires 20 and 22 are covered and fastened together by a sleeve, which together form wire 32.

[0035] FIG. 4A shows a pilot 44 wearing a helmet b attached to a mask 40. The mask 40 comprises an air hose 48 attached to the mask compartment 43. The pilot has positioned in his nose 45 the nasal probe 10 shown in FIG. 1. Wire 32 containing wires 20 and 22 passes through hole 42 defined in the mask compartment 43. It will be appreciated by those skilled in the art that the wire may be secured a number of different ways in the mask and/or air hose 48. For example, the hose 48 may have a channel defined therein through which the wire 32 may pass. The embodiment shown in FIG. 4 would most likely comprise fastening the wire 32 to the outside of the hose 48 so that it does not obstruct the actions of the pilot 44. The wire 32 carries the signals from the photodetector to a signal processor and analyzer unit to be discussed in further detail herein. It is important to reiterate that the probe used in conjunction with the mask, nasal, cheek or otherwise, is not limited to the embodiment specifically shown. The mask 410 shown in

FIG. 4B is a typical mask designed for non-invasive ventilation and the mask 412 shown FIG. 4C is a nasal only mask commonly used for sleep disorders and/or used for therapies such as oxygen and noninvasive positive pressure ventilation therapies. These masks may be modified to incorporate a probe for obtaining photoplethysmography readings from a central source site (such as the nasal alar or nasal septum similar to that described and shown in FIG. 1). Mask 410 comprises a compartment portion 421 configured for covering the nose and mouth comprising a compartment that defines a space into which gas is disposed. The compartment portion 421 is held to the face by strap 411. A probe 419, with alternative CO<sub>2</sub> sensor attached or integrated (429), is shown present in the compartment portion 421 which may take the form of any of the probe designs discussed herein. Note that CO<sub>2</sub> sensor may be separate from probe 419 but nonetheless associated with mask 410. Wiring 418 from the probe 419 associated with the mask 410 may be used to attach a small battery pack 420 for extended monitoring life and/or to attach a wireless transmitter 422 for remote monitoring of the users status. Such features may also be implemented with other masks and/or helmets. Mask 412 comprises a nasal gas delivery portion 423 which is configured with two nasal projections 425 configured for delivering gas to the nasal passages. The mask 412 is held to the face with strap 413.

[0036] In addition, masks for protection from hazardous vapors or smoke (e.g. emergency care providers, firemen, or other hazardous environments, scuba, etc.) can also be modified to incorporate a probe for obtaining photoplethysmography readings. In many of these situations, it is envisioned that the masks could be wirelessly connected to a control or central location for continuous monitoring of the health and wellbeing of the emergency provider, pilot, or hazardous material crew. In one embodiment the probe, could be built into an emergency responder's helmet 414 or mask 416 such as that shown in FIGS. 4D and/or 4E. The helmet 414 comprises a head cover portion 430, preferably, though not necessarily, made of a rigid material to protect the head from falling debris. Integrated with the head cover portion 430 could be a tail portion 432 designed to extend protection to the neck and upper back. A probe (not shown) designed for obtaining photoplethysmography readings from a central source site is associated with the helmet 414 and mask 416, optionally with cabling (not shown) to a battery pack and/or wireless transmitter. The term 'associated' or 'associating' as used herein means that the probe is attached, tethered such as via a cable, or integrated such as being embedded, to one or more parts of the helmet or mask. Also contemplated herein are probe embodiments comprising a wireless transmitter and battery supply as one enclosed unit thereby alleviating the need for wiring to separate components. The helmet is also secured to the head via strap 415. Typically, a protective pad portion 435 lies between the strap 415 and the user. The mask 416 may also comprise a strap like that shown in FIG. 1 which holds the mask 416 to the user's face. A preauricular or postauricular probe could be associated with such strap or protective pad portion 435.

[0037] In an alternative embodiment, a pre-auricular probe (or post-auricular probe) could be associated into a mask system as well. In this embodiment, as shown in FIG. 4C, a probe 427 is attached to the strap 413. The straps can provide an advantageous means for associating the cabling as well as

for securing the probe in the proper position. It is contemplated that an auricular probe may be implemented into straps **411** or **415** as well.

**[0038]** Furthermore, the mask and/or helmet embodiments may include a CO<sub>2</sub> sensor that is associated with the mask or helmet. The CO<sub>2</sub> sensor may be a part of the pulse oximeter probe or as a separate sensor. Alternatively, a sampling apparatus to obtain exhaled gases for determination of carbon dioxide content, may be associated with the mask and/or helmet. See PCT/US2004/043610.

**[0039]** It is contemplated that one or more subjects may need to be monitored remotely. For example, it is contemplated that a team of firemen working in a dangerous environment may be monitored to increase their safety. In such example, the masks worn by the firemen comprise wireless transmitters that are communicatingly connected to a remote computer. The remote computer has processing module(s) and program code module(s) enabling the analysis of signals from the probe to evaluate blood flow and/or respiration so as to warn a user of when a fireman is approaching a dangerous physiological condition. A similar system may be implemented for remotely monitoring one or more subjects in other contexts as well, including a military environment or a hospital environment with a nurse station to remotely monitor patients. A basic system embodiment is shown in FIG. **19**. In this embodiment, a remote monitoring computer **1910** is communicatingly connected to a plurality of probes **1912**. A user at the remote station is able to monitor signals of blood flow, respiration, CO<sub>2</sub>, and/or oxygen saturation of one or more subjects. This increases the safety of the subjects as the remote station can provide an early warning for when the subject is experiencing dangerous physiological circumstances.

**[0040]** Turning to FIG. **5**, there is shown a system **50** for processing signals obtained from a pulse oximeter probe being worn by a pilot and conducting a reaction responsive to certain information received from said pulse oximeter probe. The system comprises an analyzer unit **58** that is configured to receive and process signals from lines **52** and **54**. Those skilled in art will appreciate that the signals may be preprocessed to some degree by a separate signal processor and subsequently sent as one signal stream to said analyzer unit **58**. Thus, the analyzer unit **58** is configured to receive signals from either lines **52** or **54** or a combination of both. The analyzer unit **58** comprises a processing module **56** comprising software and/or electrical/circuitry components to determine whether the signals received from the pulse oximeter probe correlate to a loss in blood volume indicative of inducing GLOC. The analyzer unit **58** may also comprise a second processing module configured to generate a warning signal.

**[0041]** During a typical high +Gz maneuver, a pilot is trained to take in a maximal deep breath as quickly as possible and to either hold it for a short period of time while bearing down and then performing a rapid forced exhalation, or alternatively, to take in a deep breath and force the air out continuously against pursed lips. With either maneuver, the idea is to “trap” oxygenated blood in the head temporarily (3-5 seconds) and then rapidly allow the blood to return to the lungs. These maneuvers are repeated at 5-10 second intervals throughout the high +Gz period. It is both important to take in a maximal inspiration and then also to bear down and release the breath against resistance. Taking in a deep breath and bearing down forces blood to the head, but

if the maneuver is held for too long, venous return to the heart is impeded, flow to the brain decreases and GLOC ensues. Thus, maneuvers to prevent GLOC are a “double edged sword” and must be performed correctly or they can actually exacerbate GLOC.

**[0042]** The disclosed system can be used during centrifuge and aircraft training to provide real time feedback via visual and/or auditory cues to help the pilot optimize these maneuvers. Additionally, when optimal maneuvers are obtained, the system can store the plethysmogram that signals the onset of GLOC. This may be a system that evaluates the amplitude of the pre-+Gz plethysmogram and then recognizes when the plethysmography signals have decreased by a predetermined percentage of the pre-+Gz value which is individualized for each pilot and determines when GLOC is impending (as defined herein a pre-GLOC condition). Numerous factors including the physical characteristics of the pilot influence their ability to withstand sustained +Gz loads. The individualized information can be loaded into a computer system that continually evaluates the plethysmogram (and therefore blood flow to the head) both during level flight and during +Gz maneuvers and based on predetermined data can determine that the pilot is about to experience forces and declines in blood flow to the head which will result in GLOC if the high +Gz load is maintained. Previous research indicates that unconsciousness ensues approximately 5-8 seconds after cerebral blood flow (CBF) decreases by 72-80% from baseline flow. (Florence G, Bonnier R, Riondet L, Plagnes D, Lagarde D, Van Beers P, Serra A, Etienne X, Tran D. Cerebral cortical blood flow during loss of consciousness induced by gravitational stress in rhesus monkeys. *Neurosci Lett.* 2001; 305:99-102.).

**[0043]** The GLOC warning system could be designed to evaluate the amplitude of the plethysmograph just as +Gz acceleration begins and monitor the amplitude of the plethysmograph during the +Gz maneuver. At a preset percentage of the pre +Gz amplitude an alarm can be actuated. If the pilot does not respond to the alarm and the amplitude continues to drop towards the critical decrease in CBF (e.g., 65-85% below baseline flow) the autopilot could take control and decrease the +Gz load until the plethysmograph amplitude increases above a critical level.

**[0044]** Thus, according to another embodiment, as shown in FIG. **16**, the subject invention pertains to a method of obtaining an individualized profile concerning the amount of Gz load and duration likely to effect a lowering of head blood flow of an individual to cause GLOC, the method comprising subjecting the individual to a Gz load increase gradient **900**, monitoring the blood flow to the head through use of a pulse oximeter at a central location **910**; determining the decrease of blood flow and duration of decrease blood flow that causes GLOC for the individual **920**; obtaining a data profile for the individual **930**; and loading the data profile onto an aircraft computer **940**. The implementation of a personalized data profile increases the accuracy of predicting when an individual will undergo GLOC, and can therefore be used to better avert GLOC for the individual. In particular, the processing module containing the data profile can establish a pre-GLOC condition for the individual that when triggered will actuate an alarm and/or direct the aircraft computer to take corrective maneuvers. The terms “pre-GLOC condition” or “condition(s)” represent an empirically determined blood flow and duration conditions preceding GLOC for an individual, and likely to lead to

GLOC, but which are established at a predetermined time sufficiently in advance of GLOC so as to allow a pilot to react to avoid GLOC. Use of the personalized profile also will avoid unnecessary false alarms for the individual, which will give the pilot more control over the aircraft, as the physiological conditions sufficient to induce GLOC will vary from pilot to pilot. The pilot can be subjected to Gz loads through use of a centrifuge, air flight maneuvers, or other Gz load producing means. The centrifuge is the most preferred means, as it can be closely controlled and monitored.

**[0045]** In an alternative embodiment, GLOC avoidance training can be implemented using the methods of the subject invention. By closely monitoring the physiological conditions leading up to GLOC for the individual pilot, each pilot can be trained to sense when they are about to enter GLOC and properly react with the valsalva maneuver or other corrective actions. In a preferred embodiment, as part of the training process, the pilot is given a feedback signal to inform the pilot when he is entering a pre-GLOC condition. This will assist in the pilot correlating internal feelings and sensations associated with the pre-GLOC condition in order to more quickly recognize the condition. Furthermore, as is discussed, infra, holding the valsalva maneuver too long can have a counterproductive effect. Utilizing the subject training methods will allow the pilot to practice and refine the optimal valsalva maneuver techniques. Feedback signals may be implemented which will assist the pilot in properly timing the valsalva maneuver techniques.

**[0046]** Referring back to FIG. 5, in the system embodiment 50, the analyzer unit 58 is shown as integrated into the aircraft computer 51. The aircraft computer 51 comprises a processing module 59 configured to automatically conduct a corrective flight maneuver with and/or without input from the pilot. The aircraft computer 51 is also connected to an alarm 55 that is actuated upon analyzer unit 58 sending a signal to said aircraft computer 51 indicating a predetermined low-level blood flow. In a specific embodiment the detection and monitoring of changes in blood flow comprises establishing a baseline value of plethysmography signals under normal Gz conditions, and then comparing later obtained plethysmography signals to said baseline value. In a typical embodiment, the analyzer unit comprises a processing module configured to establish the baseline value, continuously monitor the signals and compare to the baseline value.

**[0047]** FIG. 6 shows an alternative embodiment system 60 for processing signals obtained from a pulse oximeter probe being worn by a pilot and conducting a reaction responsive to certain information received from said pulse oximeter probe. The system 60 comprises an analyzer unit 68 is a stand-alone unit connected to wires 52 and 54. The analyzer unit 68 is connected to an aircraft computer 61 through line 63 and directly to an alarm 65 through line 67. Upon the analyzer unit 68 determining low blood flow, the analyzer unit 68 may actuate an alarm 65 in conjunction with sending the low blood volume signal the aircraft computer 61. For the sake of redundancy, the aircraft computer 61 may also be connected to the alarm 65 via wire 69. Like system embodiment 50, the aircraft computer 61 comprises at least one processing module (not shown) configured to conduct a corrective flight maneuver. It is also contemplated that such a system may also be used for the identifying reduced blood flow to the head in patients and provide appropriate alarms.

It may also serve as input into a control system. The control system could adjust positive end expiratory pressure (PEEP), CPAP, or other ventilatory mode to ensure adequate blood flow, adjust oxygen delivery to ensure adequate central oxygenation, adjust drug or fluid delivery systems, or automatically adjust certain controllable aspects of the environment that may help alleviate decreased blood flow (e.g. decrease aircraft turn rate to decrease induced gravitational forces). See PCT application PCT/US06/15763.

**[0048]** The alarm 55 or 65 may be visual and/or audible in nature, such as a light being actuated on the flight panel or a speaker sounding an alarm such as a buzzer. The aircraft computer may also comprise at least one processing module for directing the plane to take corrective flight maneuvers designed to unload the wings of the aircraft so as to decrease the Gz loads on the pilot. One example of such a maneuver includes, but is not limited to, leveling the plane to a steady attitude and altitude decreasing the pitch to level flight attitude. Another example includes immediately leveling the wings while in a steep (60-90 degrees bank angle) high speed turn. The wings' level attitude is designed to induce blood flow to the brain.

**[0049]** The term "aircraft" as used herein refers to any type of craft designed for traveling above the ground. Aircraft is also used in a broader and uncommon sense as to refer to any traveling vehicle that, by the nature of its speed, acceleration and maneuvering, generates force that may induce GLOC in the operator of such aircraft, including vehicles designed for operation on the ground.

**[0050]** The term "wire(s)" as used herein refers to any structure having conductive properties to carry electrical signals. The term wire also is used in an uncommon fashion to denote that the two structures the term wire is used to connect may be substituted by a wireless means of transmitting electrical signals between the two structures. Alternatively, where wires are used to carry signals from the probes to another component, such wires may be substituted with a wireless means of transferring the signals. For example, conventional transmitter/receiver devices could be implemented in the probe and the component to which the probe sends it signals.

**[0051]** The term "communicatingly connected" as used herein refers to any connection either via wires or wireless connection, that is sufficient to convey electrical signals to and/or from at least two components that are communicatingly connected.

**[0052]** As used herein, the terms "signals indicative of blood flow" refers to signals corresponding to blood volume changes in tissue caused by passage of blood, i.e., signals indicative of perfusion or blood flow. See Murray and Foster, *The Peripheral Pulse Wave: Information Overlooked*, *Journal of Clinical Monitoring*, 12:365-377 (1996). Typically, these signals are derived from a pulse oximeter probe which produces a waveform produced as a result of absorption of delivered energy (e.g. via a light source) by hemoglobin in red blood cells. Such signals are referred to herein as plethysmography signals.

**[0053]** The term "processing module" may include a single processing device or a plurality of processing devices. Such a processing device may be a microprocessor, microcontroller, digital signal processor, microcomputer, central processing unit, field programmable gate array, programmable logic device, state machine, logic circuitry, analog circuitry, digital circuitry, and/or any device that manipu-

lates signals (analog and/or digital) based on operational instructions. The processing module may have operationally coupled thereto, or integrated therewith, a memory device. The memory device may be a single memory device or a plurality of memory devices. Such a memory device may be a read-only memory, random access memory, volatile memory, non-volatile memory, static memory, dynamic memory, flash memory, and/or any device that stores digital information.

[0054] Turning to FIG. 7, a pre-auricular reflectance probe 500 is shown. The pre-auricular region is the region in front of the ear. This probe 500 comprises a wiring harness 515 having at its distal end 511 a probe base structure 510 and at its proximal end 512 a connector 520. The pre-auricular reflectance probe embodiment 500 is designed to be secured around the user's ear with the probe base structure 510 typically secured just in front of the tragus of the ear. The probe base structure 510 may be flexible but is preferably rigid or substantially rigid, so as to not bend or deform during use of the probe 500. In a preferred embodiment, the wiring harness is made of a flex circuit such as, but not limited to, those offered by Minco Products, Inc., 7300 Commerce Lane, Minneapolis, Minn. 55432-3177 U.S.A. or NorthPoint Technologies, 207 E. Park Ave., Mundelein, Ill. 60060. The connector 520 may be any suitable connector so as to bring the wires of the wiring harness 515 into electrical communication with a corresponding receptacle with another wire connected to the analyzer unit, or directly onto a receptacle on the analyzer unit.

[0055] As shown in FIG. 8, the wiring harness 515 comprise wires 516 made of a conductive substance sufficiently insulated. Wires in the wiring harness 515 are connected to the LED 514 and the photo detector 512 (e.g., a photodiode) of the probe base structure 510. The wiring harness 515 may be provided with an adhesive material 524 that assists with the securement of the probe embodiment in place around the ear and in front of the tragus. Before securing the probe 500 in place, a peel-back layer 525 is removed and the adhesive material 524 adheres the probe to the skin of the user.

[0056] The pre-auricular reflectance probe 500 is designed to obtain plethysmography readings and/or oxygen saturation measurements of the temporal artery. The temporal artery is an ideal target since it directly branches off the carotid artery (which is the primary artery to one hemisphere of the brain). The LED 514 directs light to the temporal artery, and depending on the amount of blood flow, or oxygen saturation, the blood in the temporal artery will absorb a quantum of the emitted light. Some of the light is reflected out from the temporal artery and sensed by the photo-detector 512. The amount of light reflected is directly correlated with the amount of blood and/or oxygen saturation of the blood present in the artery. The spacing between the LED 514 and photo detector 512 is critical for obtaining accurate measurements. The space between the LED 514 and photo-detector 512 is typically in the range of about 5 mm to about 35 mm. Preferably, the space is in the range of about 10 mm to about 20 mm. The most preferred range is of the space is about 12 mm to about 16 mm.

[0057] In an alternative embodiment, the subject invention is directed to a probe embodiment similar to the pre-auricular reflectance probe, or just the probe base structure with the at least one LED and photodetector, which is embedded into a pilot's helmet, such as in the padding of the helmet. The probe is embedded into the pilot's helmet at a

location such that the probe is positioned and stabilized at the pre-auricular region, upon placement of the helmet on the user's head. Accordingly, in a typical embodiment, the probe is embedded in the padding of a helmet that covers or is proximate to the user's ear. Similarly, the probe may be embedded into or otherwise associated with a fireman's helmet such as that shown in FIGS. 4D and 4E.

[0058] FIGS. 9-12 show a nasal probe embodiment 800 configured for obtaining plethysmography readings and/or oxygen saturation readings from the user's nasal alar region. The nasal probe embodiment 800 comprises a base portion 813 which runs along the longitudinal ridge of the nose. At the distal end 833 of the base portion 813 is a bridge portion 819. The bridge portion 819 runs transversely across the nose and comprises a right flap portion 812 at one end and a left flap portion 817 at its left end. The right and left flap portions 812, 817, respectively, are positioned above the right and left nares of the user. The left flap 817 has attached thereto or integrated therewith at least one LED 810 or other light source. Extending down from the right and left flaps 812, 817 are a right extension 823 and a left extension 824. Attached to or integrated with the left extension 824 is a wing fold 820 that is configured to be inserted into the user's left nostril. The wing fold 820 has at its distal end a photodiode 825 attached thereto or integrated therewith. The wing fold 820 is designed to bend over and be inserted into the user's nostril such that the photo diode 825 is positioned directly across from the LED 810 located on the exterior of the user's nose. Extension 823 comprises wing fold 814 which is designed to be inserted into the user's right nostril. The positioning of wing fold 814 in the user's right nostril provides a counter force to the wing fold 820 which would tend to pull the probe 800 towards the left. Thus, the right flap 812, right extension 823, and right wing fold 814 act together to assist in securing the nasal probe 800 in place. As shown in FIG. 11, the nasal probe 800 is provided with an adhesive material 835 and a peel-back layer 830. Before use, the peel-back layer 830 is removed and the adhesive 835 assists in securing the nasal probe 800 to the skin of the user's nose. At the proximal end 834 of the base 813, a connector 840 is provided. Wires 836 are provided in the nasal probe embodiment and run from the LED 810 and photodiode 825 up to connector 840. Furthermore, a flex circuit as described above may be attached to or integrated with the probe embodiment 800 so as to provide the necessary wiring to the LED 810 and photodiode 825.

[0059] Through use of the novel alar probe design described above, the inventors discovered an unexpectedly superior probe position on the lateral side of the nostril just behind the prominent part, which is referred to as the fibro-areolar tissue. The inventors have surmised that this part of the lateral nostril is supplied by the lateral nasal branch of the facial artery, but there are several branches (similar to Kiesselbach's plexus found on the nasal septum). This position also includes the branches of the anterior ethmoidal artery anastomoses (lateral nasal branches), which is a branch off the internal carotid. Accordingly, the fibro-areolar tissue site is an unexpectedly optimal site for positioned a probe for use to prevent GLOC. Thus, in a preferred embodiment, the alar probe 800 is dimensioned so that placement onto the fibro-areolar region is optimized for the user. Other embodiments are contemplated as well, including clips, hooks; and reflectance designs for either inside or

outside nose, which could be inconspicuous and would be especially advantageous for ambulatory and long term use.

[0060] According to an additional embodiment, the subject invention pertains to a probe designed for obtaining readings from the post-auricular region. As shown in FIG. 17, the post-auricular region 1711 is the region behind the ear. The posterior auricular artery is a small branch directly off the external carotid. It runs posterior to the auricle and superficial to the mastoid process of the temporal bone. The proximity to the external carotid means that readings from the post-auricular region can provide improved insight to carotid blood flow than a probe on the forehead. Additionally, since collateral flow is not likely at this location it gives a good indication of unilateral flow through the carotid. The other immediate advantage is the superficial nature of the artery coupled with the relative thin layer of skin covering it. The foregoing features, plus the fact that the solid temporal bone is directly below, make the post-auricular region an ideal site for reflectance monitoring.

[0061] Another distinct advantage of the reflectance monitoring at the post-auricular region is the lack of venous blood to interfere with saturation readings, as sometimes experienced with forehead models. The thin layer of skin and strong pulsation from the artery allows for correct arterial saturations to be calculated. Other benefits include the lack of hair and fewer sebaceous and sweat glands to interfere with readings. Finally, the area behind the ear is easy to secure a probe to and it is normally out of the way of other devices. Thus, according to another embodiment, the subject invention pertains to a post-auricular reflectance probe 1700 comprising an elongated body portion 1710. The elongated body portion 1710 is curved to wrap around at least a portion of the user's ear. The elongated body portion 1710 comprises a distal end 1713 and a proximal end 1714. At the proximal end 1714, the elongated body has attached thereto or integrated therewith a probe base structure 1715. The probe base structure 1715 comprises at least one LED 1716 and at least one photodetector 1717. The at least one LED 1716 and at least one photo detector 1717 are connected to and in electrical communication with wires 1718. The wires 1718 may extend from the probe base structure 1715 and end in a connector 1719. The wires may be of varied length depending on the application. For example, the wires may end at the proximal end 1721 of the probe base structure 1715, or may run for length out of the probe base structure 1715 and connect to the aircraft computer, or components thereof (e.g. signal processing unit, analyzer unit, etc.).

[0062] In an alternative embodiment, the subject invention is directed to a probe embodiment similar to the post-auricular reflectance probe 1700, or just the probe base structure 1715 with the at least one LED and photo detector, which is embedded into a pilot's helmet, such as in the padding of the helmet. The probe is embedded into the pilot's helmet at a location such that the probe is positioned and stabilized at the post-auricular region, upon placement of the helmet on the user's head.

[0063] According to an additional embodiment, as shown in FIG. 18, the subject invention pertains to an ear canal probe embodiment 1800 for obtaining plethysmography readings from the ear canal, and more specifically the tympanic artery. The probe 1800 is tapered to assist in placement in the ear, but may alternatively not be tapered. The probe comprises an inner end 1810 which is inserted into the ear canal first, and an outer end 1820. An LED is

1812 is provided on one side of the probe 1800 with a photo detector 1814 provided on the opposite side. Those skilled in the art will appreciate that the spatial arrangement and placement of the LED 1812 and photodetector 1814 may be optimized by routine experimentation. Connected to the LED 1812 and photodetector 1814 are wires 1822 and 1824, respectively, which come together to form wire 1816. Wire 1816 exits out the outer end 1820 via exit 1818. The probe 1800 is similar to that described in U.S. Pat. No. 5,213,099, but is specifically tailored and used to obtain plethysmography readings from the ear canal. The '099 patent teaches use of an ear canal probe to obtain oxygen saturation and pulse readings, but does not contemplate or teach use of plethysmography to monitor blood flow and as a method to diminish the risk of GLOC. The inventors have found that plethysmography readings are particularly advantageous in accurately monitoring blood flow (or perfusion), and more accurately and quickly determining pre-GLOC conditions.

[0064] All of the probes described above can utilize wireless technology. The wireless technology can be used for telemetry which allows for remote monitoring of multiple patients/personnel, or also to create a cableless system for improved patient comfort. Numerous wireless protocols and systems have been developed for sensor networks including Zigbee, 802.14.5, 802.11 WiFi networks, and point-to-point networks like wireless USB, etc. Many of these new technologies are enabling very small integrated circuits and low power that could be embedded into the probes themselves. The probes would contain small rechargeable or replaceable batteries that would power the probe electronics as well as the transmission back to a base station or central station for monitoring. The processing required on the data could be done largely at the front-end (probe) or at the back-end (station) or some combination thereof. A tradeoff between computing power and transmission power would be required at the front end to minimize probe size, weight, and power consumption. For instance, higher processing power at the front end would allow for reduced bandwidth and communication power in the probe. In another embodiment, an ultra low-power sensor could be powered via capacitive coupling or RF power, thus removing the requirement for a battery pack.

[0065] An alternative embodiment would include a small cable from the sensor to a processing subsystem with power and either wired or wireless communication capability. For instance, this processing subsystem could be placed behind the ear similar to a hearing aid. It could also be attached in various "dead" spaces of the helmet or mask system or attached in a convenient location using the straps that support the mask or helmet.

#### Example 1

[0066] A pulse oximeter probe was positioned on the right cheek and left cheek of an individual. FIG. 13a shows the right and left plethysmograph readings of the individual. At a point in time, the right carotid artery of the individual was depressed thereby stopping blood flow. FIG. 13b shows the effects of pressing on one carotid artery while monitoring from both cheeks. The amplitude of the signal from the right cheek probe dramatically decreases (see arrow). FIG. 13c shows that when the carotid artery is released, the plethysmography signal from the right cheek spikes (hyperemic response, see arrow) and then returns to normal amplitude. During GLOC, the same or greater decrease in the

amplitude of the plethysmograph would be experienced from any probe monitoring from the head. It is believed that the amount of Gz load sufficient to reduce blood flow to the brain, and/or induce GLOC, varies. By knowing what percentage of pre +Gz blood flow leads to GLOC in any individual pilot a personal profile for the pilot may be produced that optimizes the alarm for that individual.

#### Example 2

**[0067]** The inventors have developed a new processing of the plethysmography signal such that important information may be extrapolated from the signal. This novel processing reveals information not before realized to be obtainable from a plethysmography signal stream. In the past, the plethysmography signal stream was typically obtained from a peripheral site such as the finger, or other extremity. It is the inventors' belief that obtaining the plethysmograph from a central site lacks much of the background noise found in the plethysmograph from a peripheral site, and it is the obtention of this "less noisy" signal that eventually led to the realization that information such as respiration rate and venous impedance can be extrapolated.

**[0068]** The raw signal stream obtained from a pulse-oximeter probe is related to the amount of light from the LED that hits the photo detector of the pulse-oximeter probe. The magnitude of the signal from the photo detector is inversely proportional to the amount of absorption of the light between the LED and the photodetector (greater absorption results in less light exciting the photodetector). The absorbed light is due to multiple factors, including absorption due to tissue, absorption due to venous blood, absorption due to arterial blood, and absorption due to the pulsation of arterial blood with each heart beat. Typically, the raw signal from the photodetector is processed (e.g. removal of artifacts and autogain of the signal) and also separated into two components. The two components are intended to be the time varying signals that are related to the beat-to-beat variations caused by the pulsation and flow of blood in the arteries (typically called the AC component), and the slowly varying components that is related to the other physiologic and physical properties of the signal, typically called the DC component (including non-pulsatile arterial blood, pulsatile and non-pulsatile venous blood and tissue and bone). The AC signal has been typically called the plethysmography and the DC component overlooked. This is explained in further detail below.

**[0069]** Typically, photoplethysmography is conducted using one pulse oximeter probe. The raw signal stream obtained from a pulse oximeter probe is related to the amount of light from the LED that hits the photodetector of the pulse oximeter probe. The magnitude of the signal from the photodetector is inversely proportional to the amount of absorption of the light between the LED and the photodetector (greater absorption results in less light exciting the photodetector). The absorbed light is due to multiple factors, including absorption due to tissue, absorption due to venous blood, absorption due to arterial blood, and absorption due to the pulsation of arterial blood with each heart beat. Typically, the raw signal from the photodetector is processed (e.g. removal of artifacts and auto gain of the signal) in order to obtain an arterial oxygen saturation value and the plethysmograph is largely ignored. Significant confusion and overlap exists in the terminology used in describing various aspects of pulse oximetry. On one hand, the terms AC

component and DC component are used to describe the anatomical structures responsible for the photoplethysmograph (AC component—pulsatile blood flow in arteries, arterioles and possibly capillaries) and the components responsible for attenuating the signal (DC component—venous blood, tissue, bone, etc.) The terms are also used to describe the phasic rapid pulsatile flow in the arteries and arterioles as seen in the plethysmography (AC component) as contrasted with slower (DC) components of the plethysmograph.

**[0070]** As the AC component and DC component can have different meanings in the art depending on the context of the situation, for the sake of further clarity, the AC component will also be referred to herein as the "pulsatile arterial" component (PAC), and the DC component will also be referred to herein as the "venous impedance" component (VIC). Thus, we use the term AC component to describe a component of a processed plethysmographic signal that represents the pulsatile blood flow that is present in the vascular bed being monitored. The DC component, as used herein, is a phasic slower frequency signal that represents the venous impedance of blood in the vascular bed being monitored and is influenced by variations in intrathoracic pressure and venous blood volume. The pulsatile arterial signal has been typically called the plethysmograph and the VIC overlooked, although it is present in the signal and can be isolated as described later. A further distinction must be made between the term "DC component" and the term "DC offset". The popular usage of the term DC component has been described above. The term "DC offset" refers to the amount that the plethysmographic signal is shifted from a baseline that would be present if no light excited the photo diode. The plethysmographic signal is small relative to the magnitude of the DC offset, and "rides" on the DC offset signal. The DC offset varies with the intensity of the LEDs and the amount of light absorbed by the tissues. Thus, if the light path through tissue remains constant, the DC offset increases with increasing LED power, and decreased with less LED power. Alternatively, the DC offset increases as the path of light through the tissues decreases and decreases as the path of light through the tissues increases. Manufacturers usually have circuits built into the pulse oximeter to keep the LED power in a range in which the DC offset will be an adequate signal to discern the photoplethysmograph, but less than that which will oversaturate the photodiode.

**[0071]** According to one signal processing method embodiment of the subject invention, the effects of the individual heart beats in the plethysmograph are separated out from the other information, which is fundamentally a different goal than conventional processing, which is basically to obtain an adequate arterial component and discarding the venous impedance component. Standard practice is to implement a DC removal technique that involves removing the venous impedance component by a low pass filter. This technique, however, does not sufficiently separate all of the data from the two sources of information. The subject processing method obtains a higher fidelity signal, which is critical when dealing with precise measurements of variables for determining, for example, respiratory events in a patient.

**[0072]** In a specific embodiment, the high fidelity pulsatile arterial component and the venous impedance component of

the plethysmography signal (previously ignored by those in the art) are achieved by unique signal processing, comprising:

**[0073]** 1) discretely selecting the peaks and troughs of the signal (improved noise/artifact rejection can be achieved by looking for peaks and troughs that exist at the expected heart rate, estimated by Fourier or autocorrelation analysis, or from past good data)

**[0074]** 2) finding the midpoints between peaks and troughs or extreme values and interpolating between these values (possibly including smoothing or splining this interpolated signal)

**[0075]** 3) extracting the venous impedance component as the interpolated and possibly smoothed line

**[0076]** 4) extracting the pulsatile arterial component as the raw signal subtracted from the venous impedance component.

**[0077]** This processing is preferably implemented from signals obtained from a central source site, but it could be applied to signals obtained from other sites so long as the fidelity of the signal is sufficiently high and reliable. This technique achieves a nonlinear filter with zero delay and optimally separates the two signals of interest. In view of the teachings herein, those skilled in the art will appreciate that similar techniques for achieving these objectives could also be adapted, and are differentiated from the conventional processing of plethysmography signals due to their goal of optimally separating the two signals of interest on a beat-to-beat, zero delay basis (unlike standard linear filtering, DC removal techniques, and averaging techniques).

**[0078]** The AC and DC components, as described herein, are intended to be the time varying signals that are related to the beat-to-beat variations caused by the pulsation and therefore, when recorded over time, the flow of blood in the arteries (the AC component, although different from the AC component described by others), and the slowly varying components that are related to the other physiologic and physical properties of the signal related to the impedance of the venous vessels and the changes in intrathoracic pressure, the venous (DC) component which differs from the "classical" description of the DC component which is said to include non-pulsatile arterial blood, pulsatile and non-pulsatile venous blood and tissue and bone. The amplitude and area under the curve (AUC) of the AC component contains information about the amount of arterial blood flowing past the detector. In order to correctly interpret this information, the AC and DC components must be separated more rigorously than with the algorithms in standard monitors and previously described in the literature. In particular, the pulsatile arterial component should contain only that information that relates to beat-to-beat variations of the heart. The DC component should contain lower frequency effects from physiology (such as the respiratory effects, blood pooling, venous impedance, etc.) and physical sensor changes (e.g. changes in the orientation of the probe, etc.).

**[0079]** Accordingly, the inventors have discovered and characterized for the first time at least three separate components of the plethysmograph signal: (a) blood pulsation signal, (b) time-varying DC signal or venous impedance signal, and (c) the classical DC component signal which is a function of the tissue (muscle, bone, etc) at the probe site, and is the baseline DC component on which the venous impedance signal rides.

**[0080]** Pulse oximeter probes useful in accordance with the teachings herein include, but are not limited to, those described in co-pending U.S. application Ser. Nos. 10/176,310; 10/751,308; 10/749,471; and 60/600,548, the disclosures of which are all incorporated herein in their entirety.

**[0081]** As referred to above, the VIC of the photoplethysmograph is an indicator of venous impedance, while the PAC is a measure of regional blood flow. During forced airway maneuvers, intrathoracic pressure changes dramatically. These pressure changes are transmitted directly to the veins in the head, because there are no anatomical valves in veins leading to the head. Changes in intrathoracic pressure have direct effects on both the beat to beat pulsatile arterial blood flow (PAC), and the amount of venous blood in the vascular bed being monitored on a breath to breath basis. These effects are present even during quiet breathing, but are far more pronounced with "airway maneuvers" such as the Valsalva and Mueller maneuvers, and during exacerbation of respiratory conditions which increase airway resistance and/or decrease lung compliance. These pronounced changes are often referred to as "pulsus paradoxus" when measured by arterial blood pressure or direct arterial blood monitoring. All conditions which affect airway resistance (increase) and lung compliance (decrease) increase the respiratory muscle work (work of breathing for each breath, or power of breathing for the amount of work performed in one minute). As the work or power of breathing increases, there are wider swings in intrathoracic pressure which in turn lead to phasic variations in pulsatile arterial blood flow and venous impedance. Respiratory rate can be easily determined when monitoring at "central source sites" and the degree of change in both the AC and DC components are related to the degree of airway obstruction and/or lung compliance. At a given level of resistance and or compliance, variations in the amplitude and AUC of both components can also be an indication of volume status. Thus, a plethora of information on both respiratory and cardiopulmonary mechanics can be ascertained from the processed plethysmograph, especially when it is obtained from a "central source site".

**[0082]** Algorithms to evaluate the PAC and VIC include, but are not limited to, separating the high frequency information in the PAC (heart rate and above, typically above 0.75 Hz) information, the low frequency information in the VIC (e.g. respiratory rate and changes in blood flow, typically from 0.05 Hz to 0.75 Hz) and the very low frequency information in the DC offset (e.g. changes in pulse oximeter path length (positioning), typically less than 0.05 Hz). Separating these waveforms without delays or significant averaging is required to optimally extract information from the photoplethysmograph (PPG). The PPG typically has only 2-3 heart beats (the major feature of the signal) for each breath (the second largest signal). If significant averaging or delays exist, the secondary signal (VIC) cannot be reliably separated from the primary signal (PAC). Other methods exist that can be utilized to extract these signals. Wavelets allow for finer resolution at low frequencies than the more standard Fourier spectral analysis methods. Adaptive filtering may also be used to optimally adjust the cutoff frequency between the breathing rate and heart rate. If coarse information is all that is required, many standard methods can be used to separate the signals, including linear filtering, frequency domain filtering, time domain analysis such as zero-crossings and moving averages, nonlinear filtering,

modeling such as kalman filtering and ARMA modeling, and other methods known to those skilled in the art.

**[0083]** Quantification of the PAC and VIC changes can include peak or trough counting, peak-peak timing, peak-trough height, area under the curve, shape of the curves, frequency characteristics of the curves, entropy of the curves, changes in the positions of the peaks, troughs, or midpoints from heart beat to heart beat or breath to breath. Some of these parameters may need to be normalized by the LED signal power, DC offset, or the physiology of the probe placement.

**[0084]** Further, noise reduction techniques can be derived that will provide more robust detection of blood flow as well as standard pulse-oximetry techniques. Signal processing techniques such as blind source separation, adaptive noise cancellation, or other techniques that can isolate signals from difference sources can be applied to produce usable signals in the presence of large artifacts. Two different approaches can be applied. First, is to detect similarities in the artifacts for each channel and subtract the similar artifact (or prediction of the artifact from one sensor output to the other) from the raw sensor outputs. This would leave a cleaner signal with less motion artifacts. This approach will be preferred when the artifacts in multiple sensors are highly correlated, like when the sensors are attached to a single rigid structure and motion in one causes motion in the other.

**[0085]** The second approach assumes that the noise/artifacts are different but the underlying desired signal is similar. In this case, the algorithms would search for the common characteristics in each sensor output and remove signals that are highly variable between the channels. This approach could be very successful if the sensors are not collocated on the same rigid structure (e.g. you have independent noise sources) or if the noise/artifacts are highly dependent on the exact path that the light travels.

**[0086]** The above listed methods do not require that the signals come from similar sensors. For instance, auxiliary sensors can be used to determine motion artifacts are present and assist in the removal of such artifacts. One approach is to use one or more accelerometers that can detect rapid positional changes of the probe and correlate these changes with the PPG signals. Other sensors that detect or suffer from similar motion artifacts can also be used.

**[0087]** In another embodiment, an approach with multiple LEDs/photodiodes could be implemented where multiple LED/photodiode pairs are utilized and frequent testing of the signal quality produced by each pair is used. The highest quality signal could then be used and this selection could be changed over time. This would allow for more easily producing good quality signals without requiring accurate placement or ensuring that the sensors do not move over time. As described above, it is also possible to use multiple sensors simultaneously for improved data quality and these sensors could be selected from the set of available pairs. For example, multiple pairs of reflectance probes could be placed on the structure of FIG. 8, including multiple locations in the pre-auricular and post-auricular area. This would allow for physiologic variability from subject to subject and motion and non-optimal fit of the appliance to the subject.

**[0088]** FIG. 14 represents a plethysmograph from a pulse oximeter probe positioned on the cheek. The AC component is provided on the top and the DC component is provided on the bottom. Pressing on the carotid diminishes blood flow, as seen in the AC component (see arrow). Conversely, the DC

component goes up when the carotid is depressed (see arrows). This confirms the inventors' beliefs of the physiological phenomenon that is represented in the DC component. That is, for this example, the DC component increasing demonstrates that there is both less blood flowing to the cheek, and because only the artery is occluded but not venous return there is low venous impedance. The effect is that less blood is flowing to the cheek, but that blood is able to leave the cheek. Since there is less blood between the LED and photo detector, there is less absorption of the signal, resulting in a higher DC component signal.

**[0089]** By separating the AC and DC components the effects on arterial blood flow and venous return can both be evaluated, a desirable feature when monitoring variables for GLOC.

### Example 3

**[0090]** In FIG. 15, the DC component is plotted at the top and the AC component at the bottom. A finger probe was initially placed at heart level and a "baseline" AC component amplitude was obtained. The individual performed a Valsalva maneuver similar to what pilots are taught to do during sustained +Gz in order to prevent GLOC. However, the Valsalva was held for over 10 seconds and this resulted in a decrease in blood flow (reduction in AC component amplitude), a common problem causing GLOC (holding the positive pressure for too long).

**[0091]** Next, the individual placed his finger above the level of his head (while standing up). This results in the amplitude of the AC component increasing. This contradicts convention teaching regarding the AC component, which would predict the exact opposite result and demonstrates the effects of local vessel reactivity to a change in position relative to the heart. The AC component increases because there is LESS venous impedance and more blood flow probably due to local vasodilatation in arterioles in the finger between the LED and the detector and there is less venous blood in the finger as demonstrated by the increase in the DC component. The individual again performed a Valsalva maneuver and the blood flow (AC component) decreased and did the DC component due to diminished venous return.

**[0092]** Finally, the individual held his hand below the level of his heart. As the present new understanding of the different components of plethysmography signals would predict, the AC component decreased because of increased venous impedance and a decreased pressure gradient between the arterioles and the venules and the DC component decreased because there was more blood pooled on the venous side between the LED and the photodetector. The same result as above occurred during the Valsalva maneuver. Also note that there is a small, but detectable, decrease in the DC component with each Valsalva. The foregoing further demonstrates that the DC component must be adequately separated in order to obtain a highly accurate AC component signal and to demonstrate effects of the venous side (i.e. venous return).

**[0093]** The subject invention can serve as an early warning system in the clinical environment and provide the clinician with a warning that the blood flow is decreasing and can also be integrated into closed loop system. The control system could adjust positive end expiratory pressure (PEEP), CPAP, or other ventilatory mode to ensure adequate blood flow, adjust oxygen delivery to ensure adequate central oxygenation, adjust drug and fluid delivery systems, or automati-

cally adjust certain controllable aspects of the environment that may help alleviate decreased blood flow (e.g. decrease aircraft turn rate to decrease induced gravitational forces).

[0094] While various embodiments of the present invention have been shown and described herein, it will be obvious that such embodiments are provided by way of example only. Numerous variations, changes and substitutions may be made without departing from the invention herein. Accordingly, it is intended that the invention be limited only by the spirit and scope of the appended claims. The teachings of all patents and other references cited herein are incorporated herein by reference to the extent they are not inconsistent with the teachings herein.

We claim:

1. A method of monitoring an individual comprising securing a photoplethysmography probe to a post-auricular region of the individual; obtaining photoplethysmography signals from the photoplethysmography probe; and processing the photoplethysmography signals with a processing module.
2. The method of claim 1, wherein the processed photoplethysmography signals are analyzed to determine at least one of a blood flow and a blood oxygen saturation of the individual.

3. The method of claim 1, wherein the photoplethysmography probe is embedded into a helmet.

4. The method of claim 1, wherein processing the photoplethysmography signals comprises separating the photoplethysmography signals into an isolated AC component signal stream and an isolated DC component signal stream.

5. The method of claim 4, wherein at least one of the isolated AC component signal stream and the isolated DC component signal stream are analyzed to monitor the individual.

6. The method of claim 1, wherein the photoplethysmography probe is a reflectance probe.

7. The method of claim 1, wherein the photoplethysmography probe comprises

a wiring harness, and a probe base structure comprising an LED and a photodetector on the wiring harness,

wherein the wiring harness is configured to secure around a user's ear and the probe base structure is at a proximal end of the wiring harness and configured to secure to a post-auricular region of the user.

8. The method of claim 1, wherein the photoplethysmography probe obtains photoplethysmography signals from the post-auricular artery.

\* \* \* \* \*

专利名称(译)	中心光电容积脉搏波监测方法和装置		
公开(公告)号	<a href="#">US20180008155A1</a>	公开(公告)日	2018-01-11
申请号	US15/651697	申请日	2017-07-17
[标]申请(专利权)人(译)	佛罗里达大学研究基金会有限公司		
申请(专利权)人(译)	佛罗里达州研究基金会, Inc.的大学.		
当前申请(专利权)人(译)	佛罗里达州研究基金会, Inc.的大学.		
[标]发明人	MELKER RICHARD J EULIANO NEIL FUERHLEIN BRIAN		
发明人	MELKER, RICHARD J. EULIANO, NEIL FUERHLEIN, BRIAN		
IPC分类号	A61B5/0295 A61B5/02 A61B5/1455 A61M16/06 A61B5/00 A61B5/026 A61B5/024		
CPC分类号	A61M16/0683 A61B5/0295 A61M16/06 A61B5/6803 A61M16/0627 A61B5/14552 A61B5/0261 A61B5/6815 A61B5/6838 A61M2230/205 A61M2230/432 A61B5/02416 A61B5/6817 A61B5/6819 A61B5/02 A61M16/0051		
优先权	12/377706 2009-02-23 US 60/600548 2004-08-11 US		
其他公开文献	US10368758		
外部链接	<a href="#">Espacenet</a> <a href="#">USPTO</a>		

摘要(译)

根据本发明的实施方案提供了监测个体的方法，所述方法包括将光电容积脉搏波描记器探针固定到个体的耳前区域和耳后区域中的至少一个，并从光电容积脉搏波描记器探针获得光电容积脉搏波描记信号。本文还描述了与这些方法相关的光电容积描记器探针和头盔。

