



US 20170007198A1

(19) **United States**

(12) **Patent Application Publication**
AL-ALI et al.

(10) **Pub. No.: US 2017/0007198 A1**
(43) **Pub. Date: Jan. 12, 2017**

(54) **PHYSIOLOGICAL ACOUSTIC MONITORING SYSTEM**

A61B 5/024 (2006.01)
A61B 7/04 (2006.01)
A61B 5/00 (2006.01)

(71) Applicant: **MASIMO CORPORATION**, Irvine, CA (US)

(52) **U.S. Cl.**
CPC *A61B 7/003* (2013.01); *A61B 7/04* (2013.01); *A61B 5/7278* (2013.01); *A61B 5/7415* (2013.01); *A61B 5/02416* (2013.01); *A61B 5/0022* (2013.01); *A61B 5/6822* (2013.01); *A61B 5/0816* (2013.01); *A61B 5/7232* (2013.01); *A61B 5/742* (2013.01); *A61B 5/746* (2013.01)

(72) Inventors: **AMMAR AL-ALI**, SAN JUAN CAPISTRANO, CA (US); **SUNG UK LEE**, IRVINE, CA (US)

(21) Appl. No.: **15/184,951**

(22) Filed: **Jun. 16, 2016**

Related U.S. Application Data

(63) Continuation of application No. 14/522,474, filed on Oct. 23, 2014, now Pat. No. 9,370,335, which is a continuation of application No. 13/650,775, filed on Oct. 12, 2012, now Pat. No. 8,870,792, which is a continuation-in-part of application No. 12/905,036, filed on Oct. 14, 2010, now Pat. No. 8,821,415.

(60) Provisional application No. 61/547,007, filed on Oct. 13, 2011, provisional application No. 61/252,099, filed on Oct. 15, 2009, provisional application No. 61/391,098, filed on Oct. 8, 2010.

Publication Classification

(51) **Int. Cl.**
A61B 7/00 (2006.01)
A61B 5/08 (2006.01)

(57) **ABSTRACT**

A physiological acoustic monitoring system receives physiological data from an acoustic sensor, down-samples the data to generate raw audio of breathing sounds and compresses the raw audio. The acoustic monitoring system has an acoustic sensor signal responsive to tracheal sounds in a person. An A/D converter is responsive to the sensor signal so as to generate breathing sound data. A decimation filter and mixer down-samples the breathing sound data to raw audio data. A coder/compressor generates compressed audio data from the raw audio data. A decoder/decompressor decodes and decompresses the compressed audio data into decompressed audio data. The decompressed audio data is utilized to generate respiration-related parameters in real-time. The compressed audio data is stored and retrieved so as to generate respiration-related parameters in non-real-time. The real-time and non-real-time parameters are compared to verify matching results across multiple monitors.

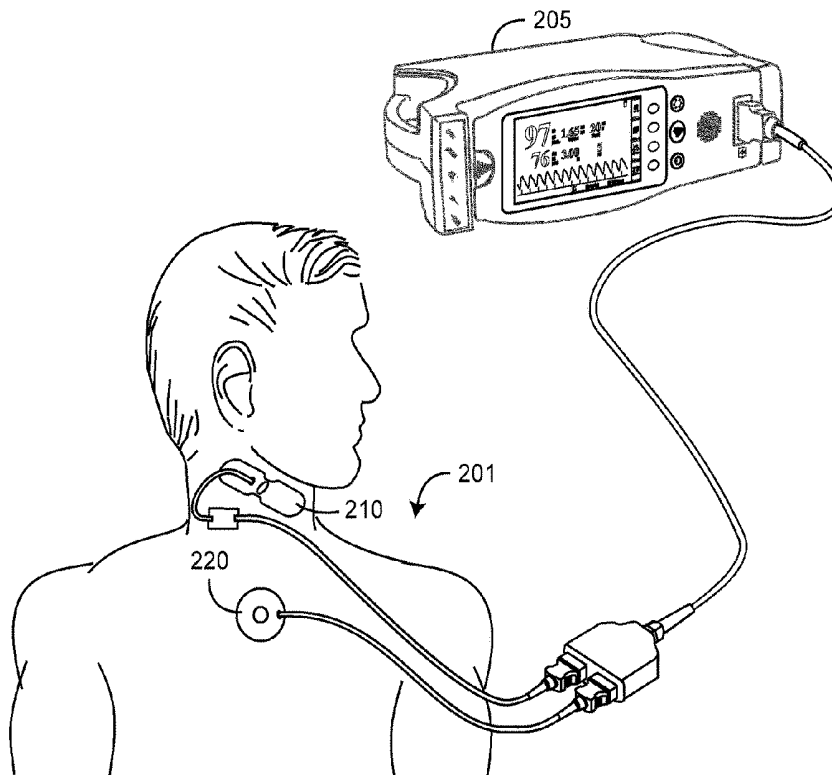

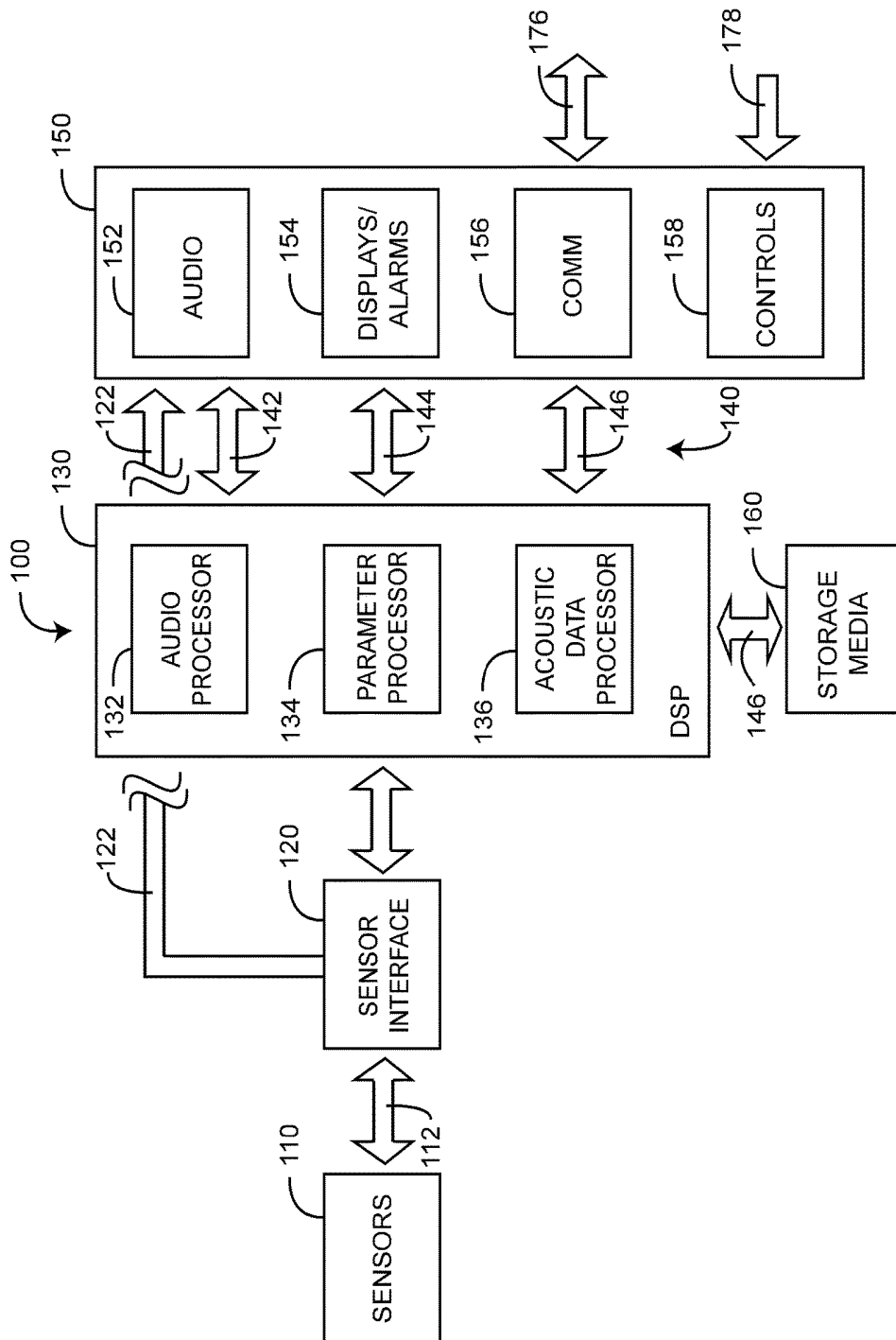

FIG. 1

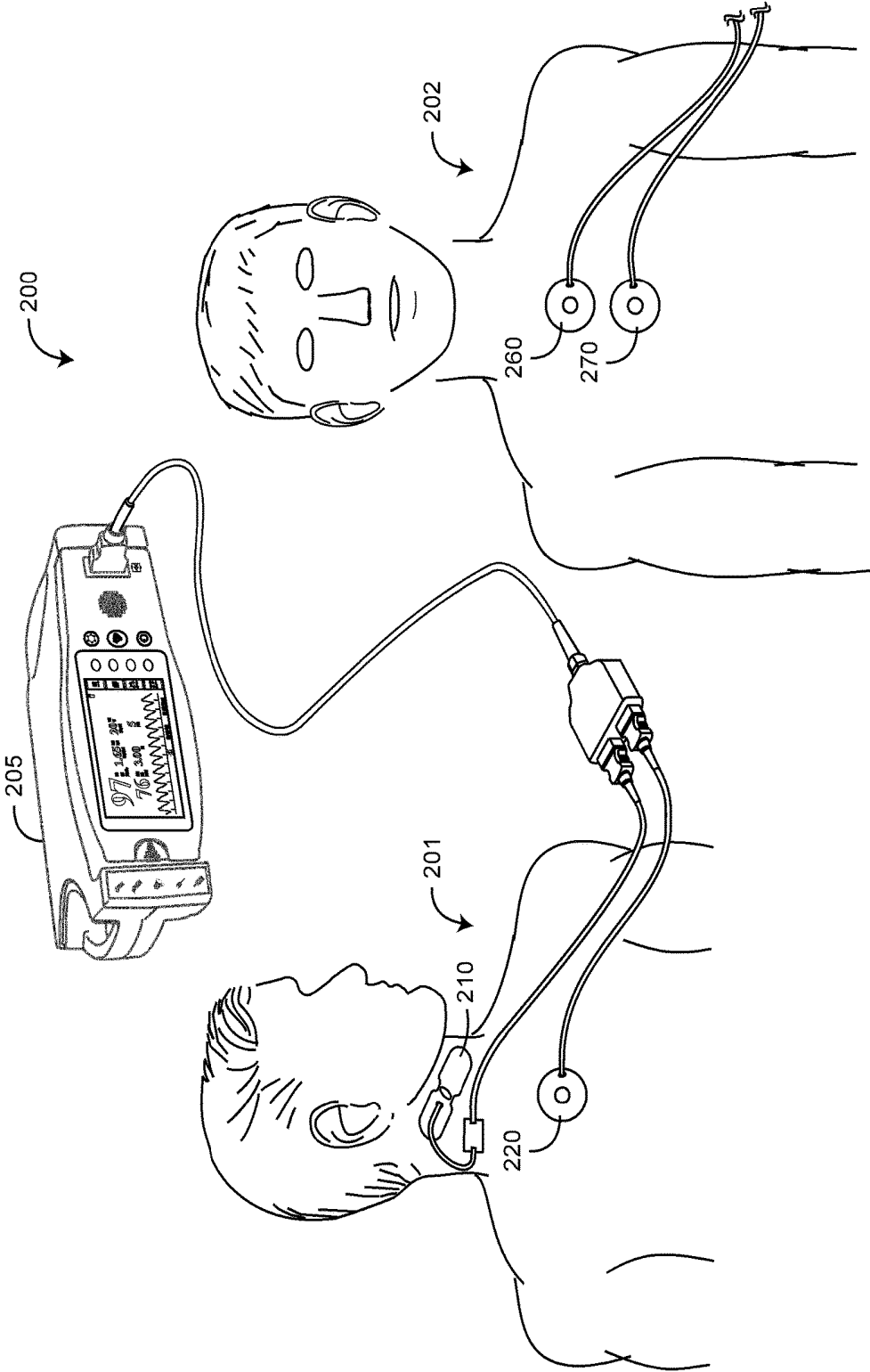

FIG. 2B

FIG. 2A

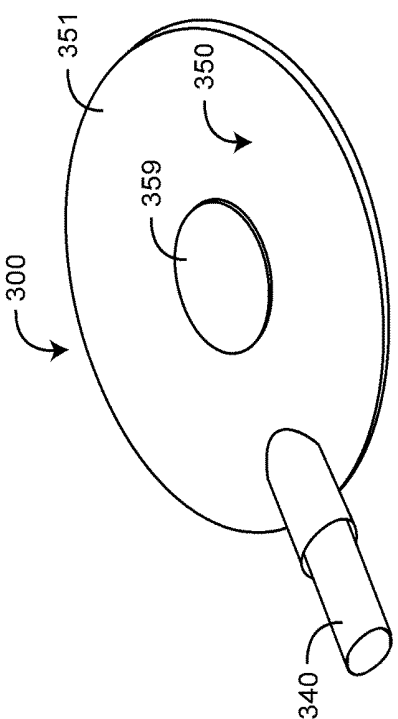

FIG. 3A

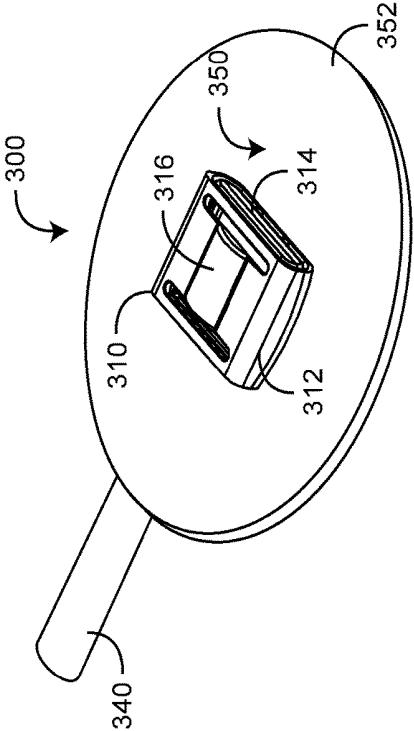

FIG. 3B

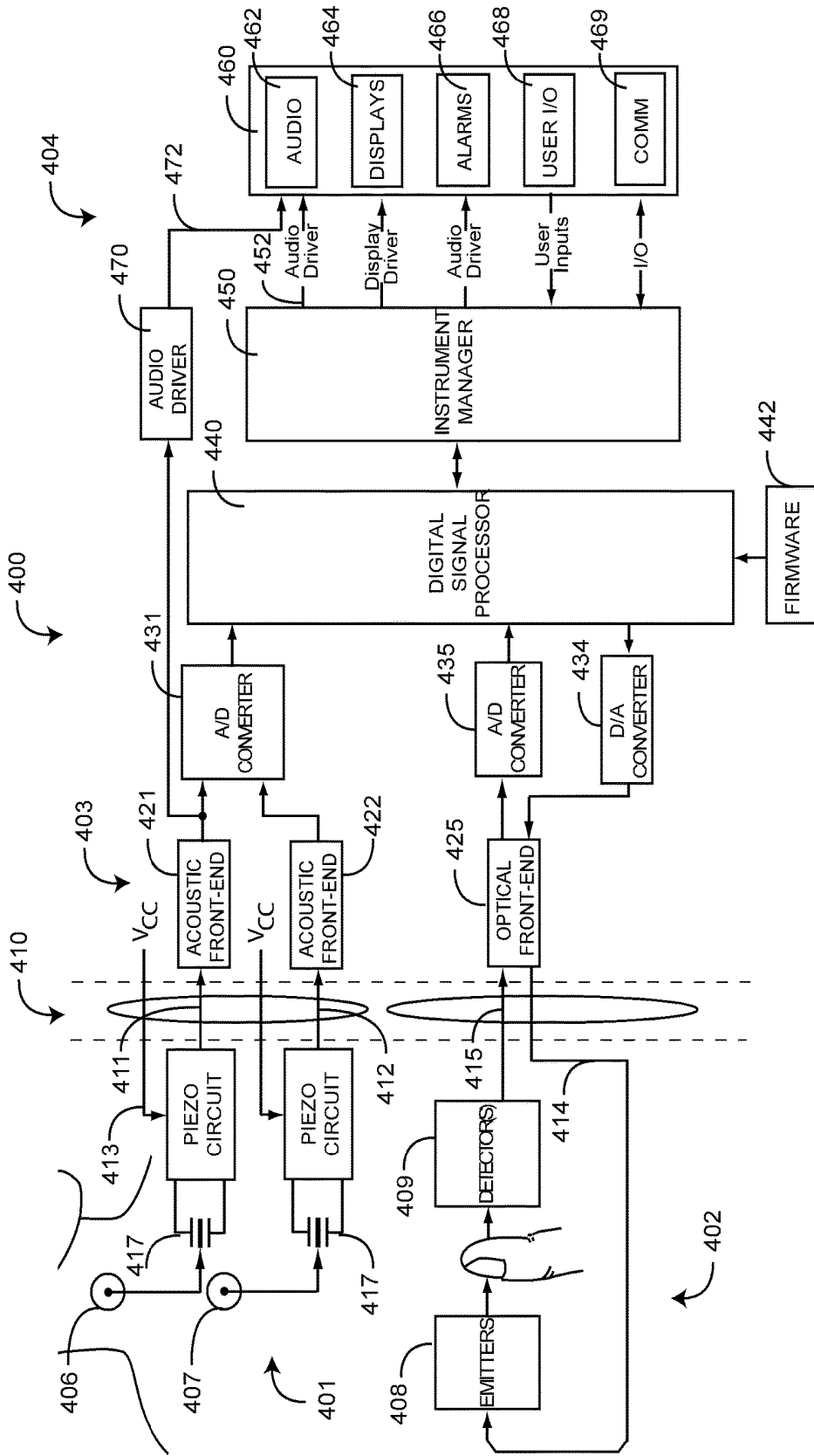

FIG. 4

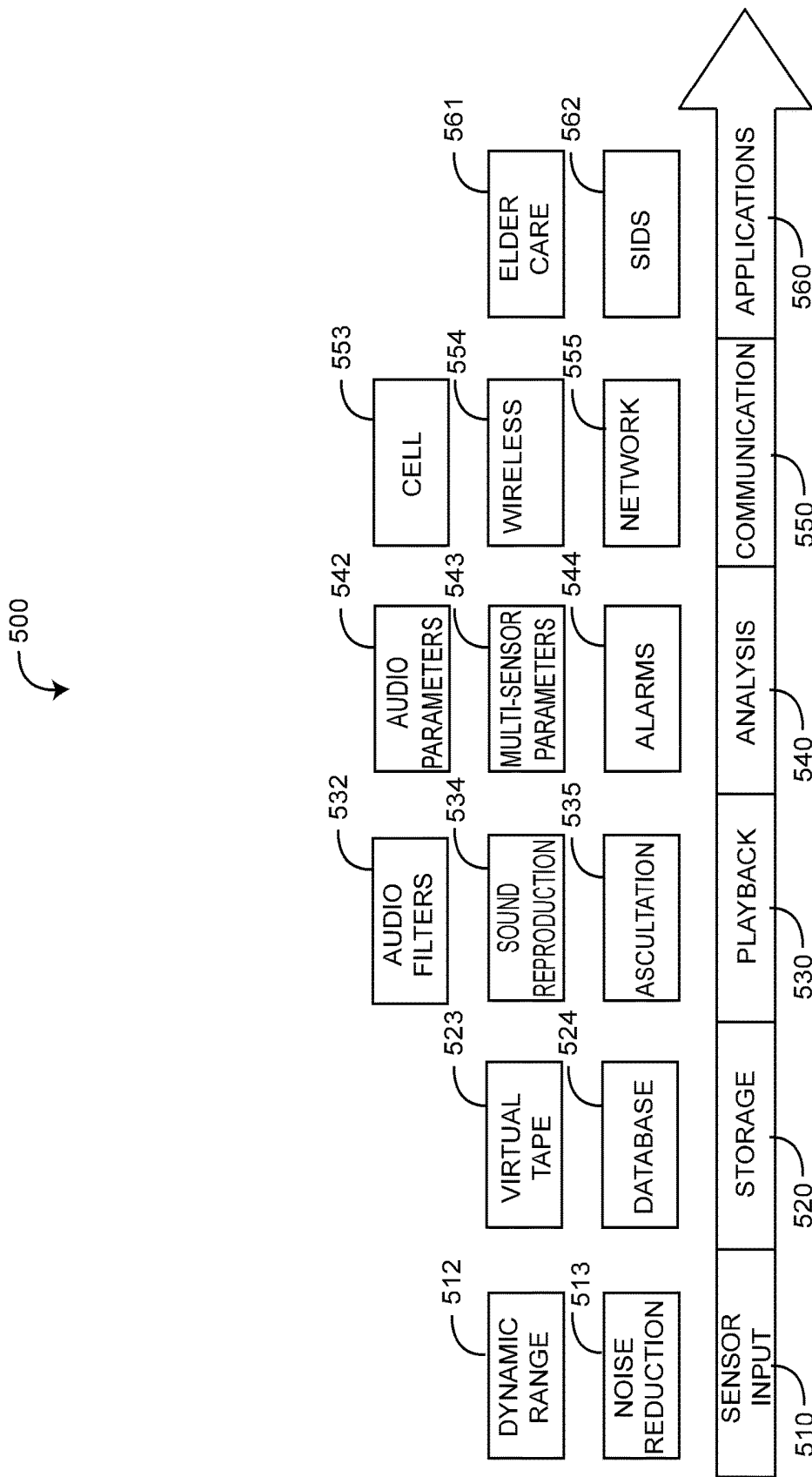

FIG. 5

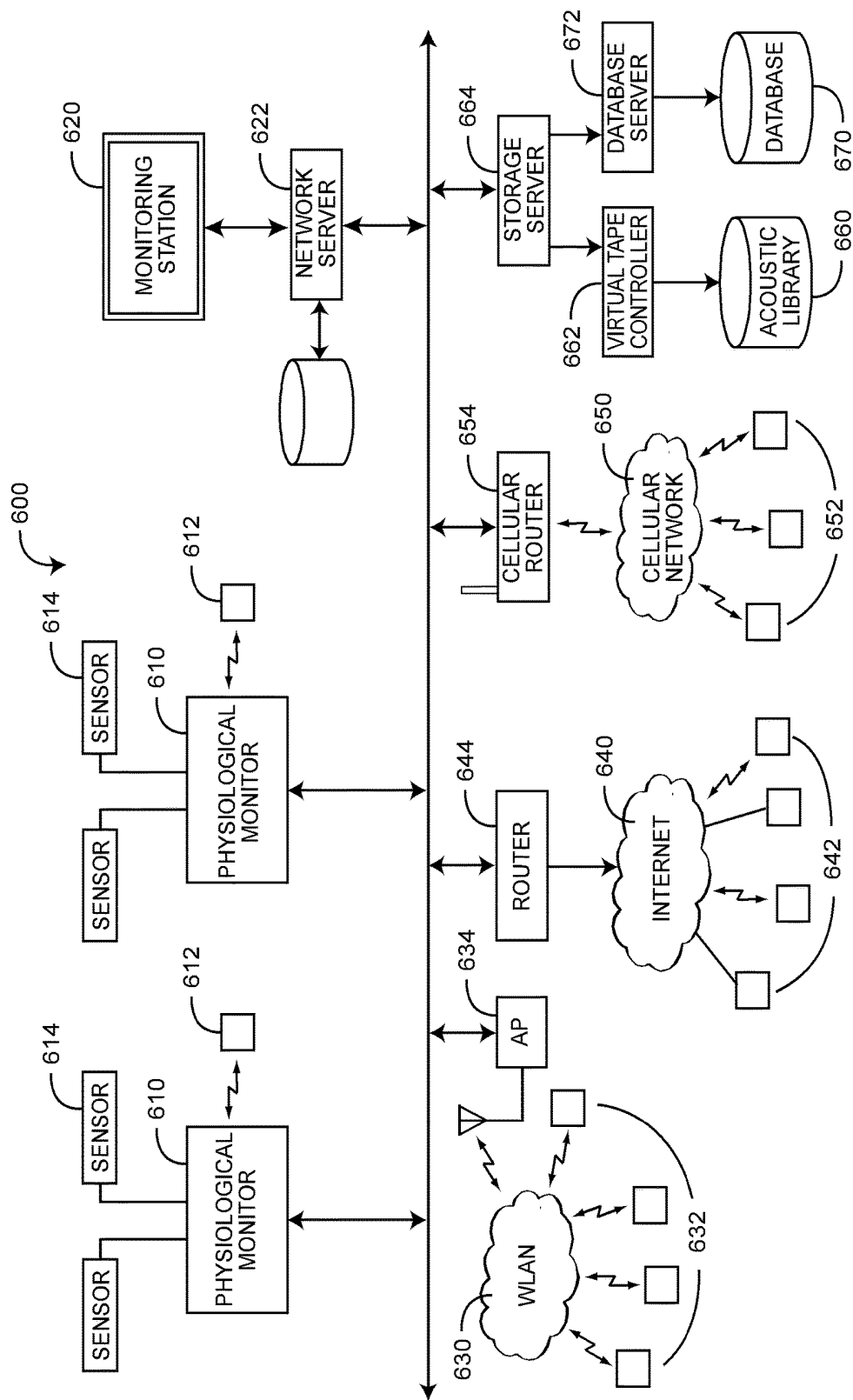

FIG. 6

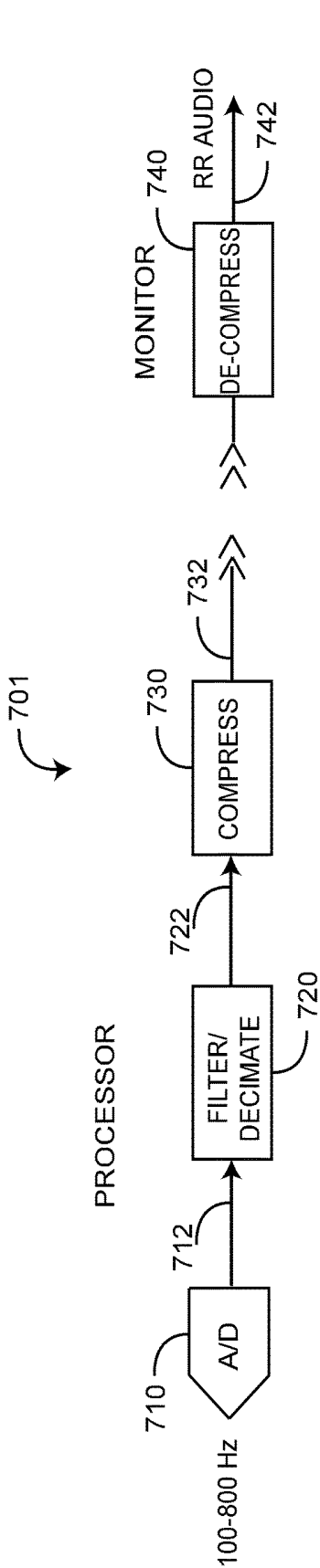

FIG. 7A

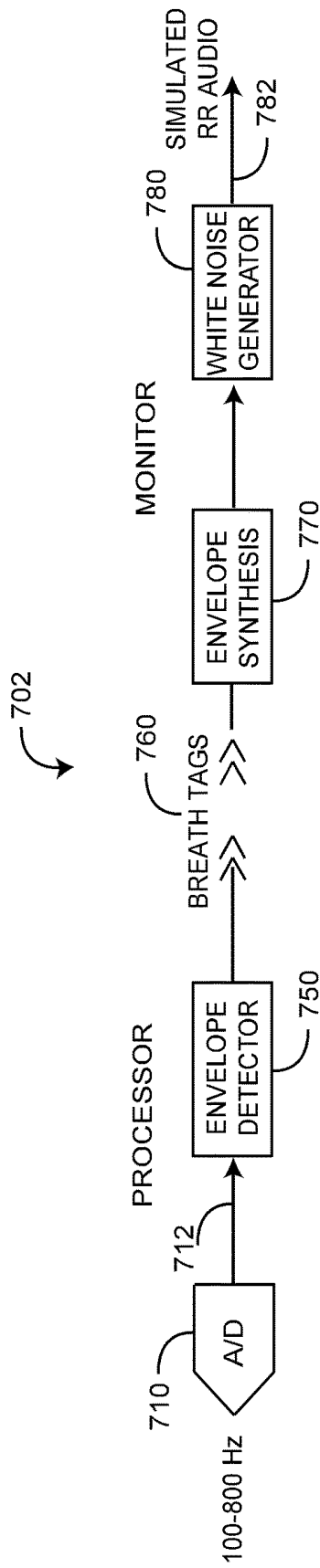

FIG. 7B

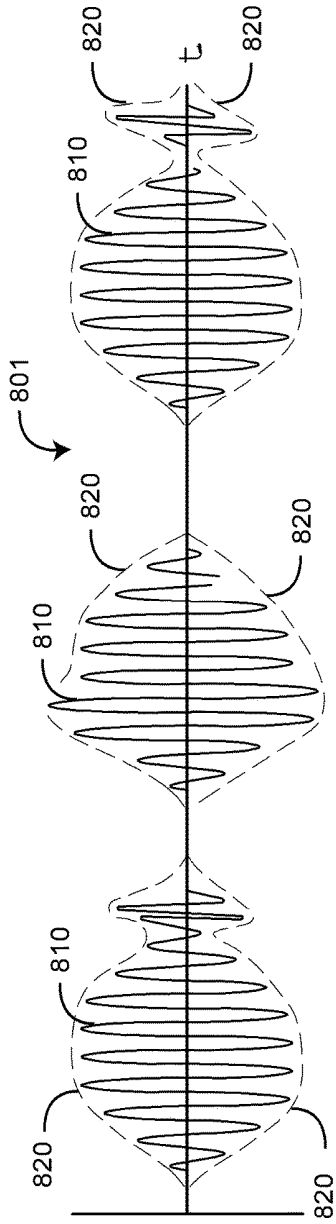

FIG. 8A

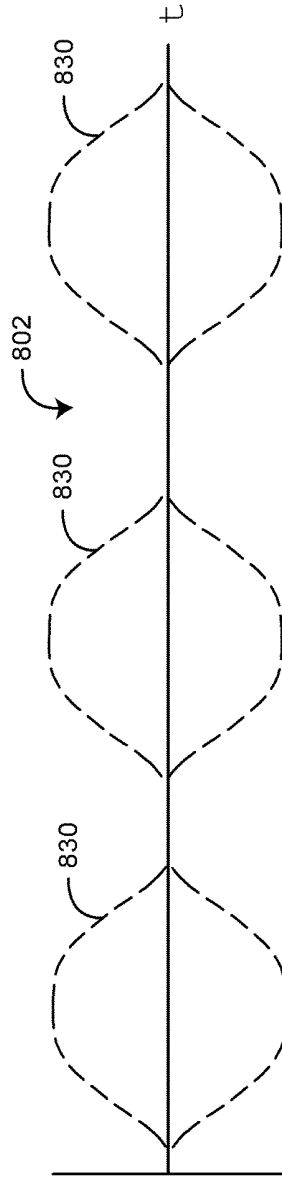

FIG. 8B

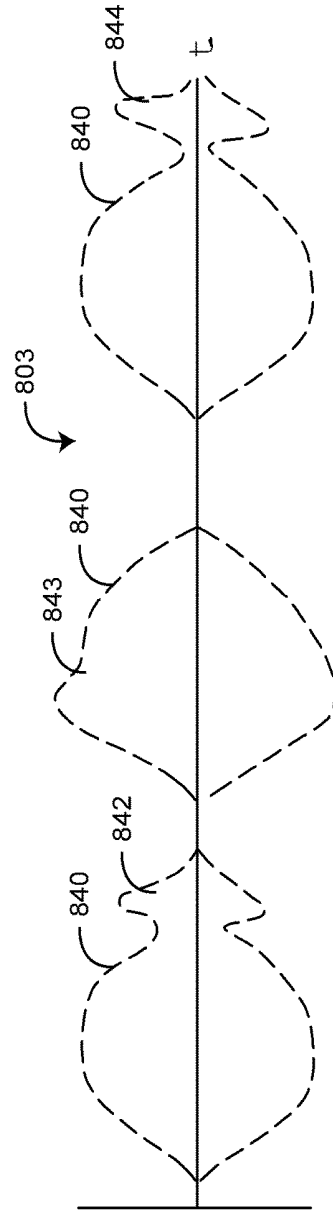

FIG. 8C

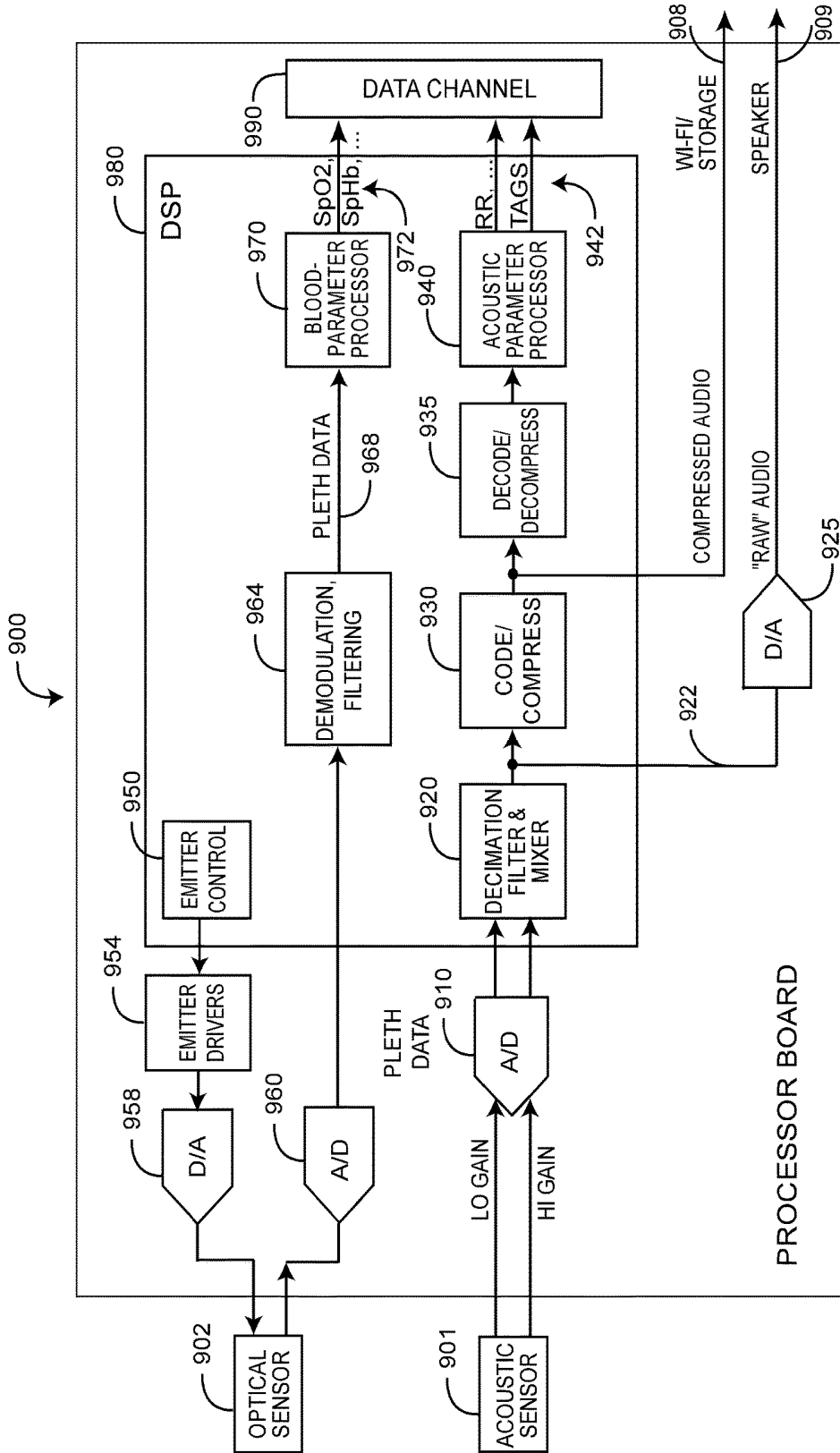

FIG. 9

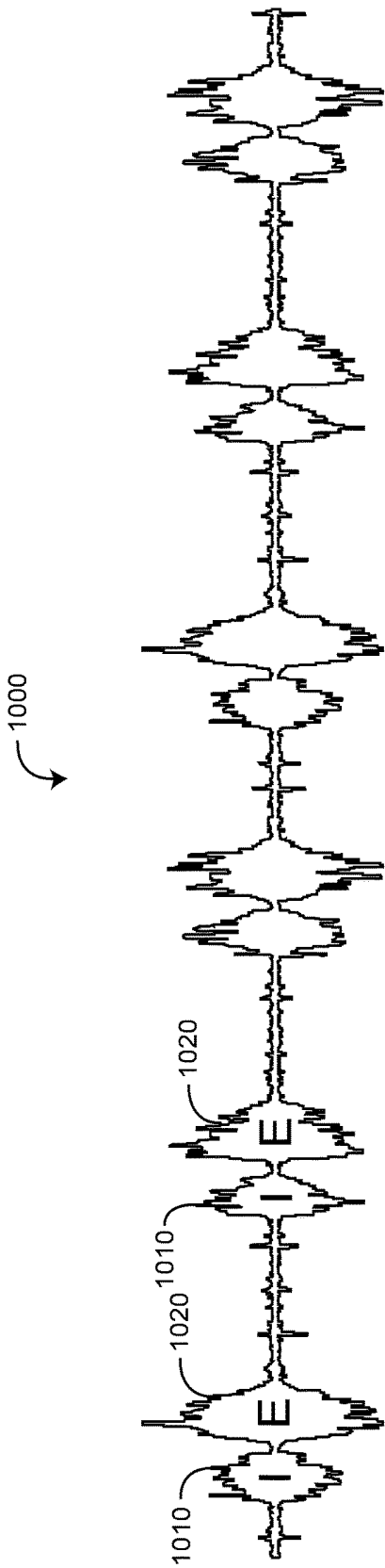

FIG. 10A

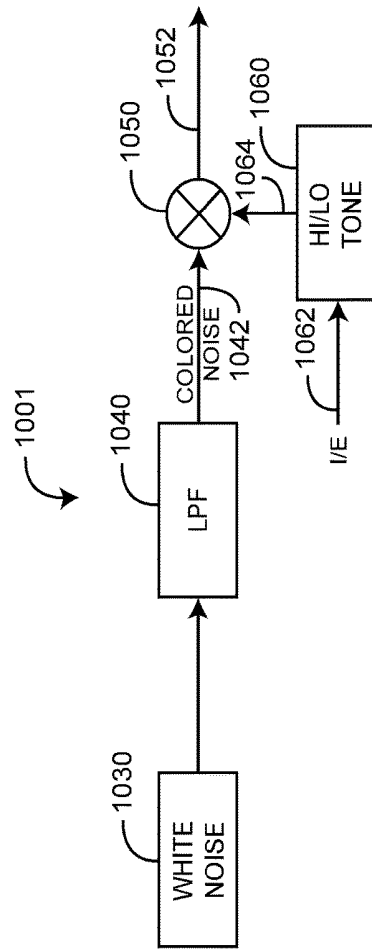

FIG. 10B

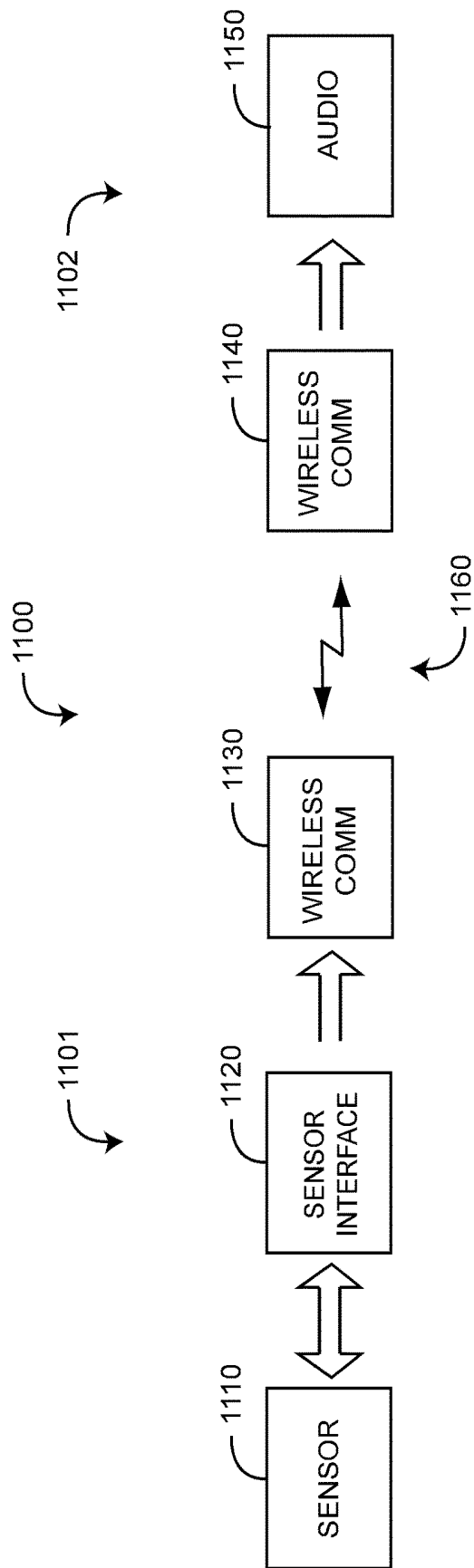

FIG. 11

**PHYSIOLOGICAL ACOUSTIC MONITORING
SYSTEM**

[0001] This application is a continuation of U.S. patent application Ser. No. 14/522,474, filed Oct. 23, 2014, titled PHYSIOLOGICAL ACOUSTIC MONITORING SYSTEM, which is a continuation of U.S. patent application Ser. No. 13/650,775, filed Oct. 12, 2012, now U.S. Pat. No. 8,870,792, titled PHYSIOLOGICAL ACOUSTIC MONITORING SYSTEM, which claims the benefit of priority under 35 U.S.C. §119(e) of U.S. Provisional Patent Application No. 61/547,007, filed Oct. 13, 2011, titled Physiological Acoustic Monitoring System, and is a continuation-in-part of U.S. patent application Ser. No. 12/905,036, filed Oct. 14, 2010, now U.S. Pat. No. 8,821,415, titled Physiological Acoustic Monitoring System, which claims the benefit of priority under 35 U.S.C. §119(e) of U.S. Provisional Patent Application No. 61/252,099, filed Oct. 15, 2009, and U.S. Provisional Patent Application No. 61/391,098, filed Oct. 8, 2010, the disclosures of which are hereby incorporated in their entirety by reference herein. Additionally, this application relates to the following U.S. patent applications, the disclosures of which are incorporated in their entirety by reference herein:

App. No.	Filing Date	Title
60/893,853	Mar. 8, 2007	MULTI-PARAMETER PHYSIOLOGICAL MONITOR
60/893,850	Mar. 8, 2007	BACKWARD COMPATIBLE PHYSIOLOGICAL SENSOR WITH INFORMATION ELEMENT
60/893,858	Mar. 8, 2007	MULTI-PARAMETER SENSOR FOR PHYSIOLOGICAL MONITORING
60/893,856	Mar. 8, 2007	PHYSIOLOGICAL MONITOR WITH FAST GAIN ADJUST DATA ACQUISITION
12/044,883	Mar. 8, 2008	SYSTEMS AND METHODS FOR DETERMINING A PHYSIOLOGICAL CONDITION USING AN ACOUSTIC MONITOR
61/252,083	Oct. 15, 2009	DISPLAYING PHYSIOLOGICAL INFORMATION
12/904,823	Oct. 14, 2010	BIDIRECTIONAL PHYSIOLOGICAL INFORMATION DISPLAY
61/141,584	Dec. 30, 2008	ACOUSTIC SENSOR ASSEMBLY
61/252,076	Oct. 15, 2009	ACOUSTIC SENSOR ASSEMBLY
12/643,939	Dec. 21, 2009	ACOUSTIC SENSOR ASSEMBLY
61/313,645	Mar. 12, 2010	ACOUSTIC RESPIRATORY MONITORING SENSOR HAVING MULTIPLE SENSING ELEMENTS
12/904,890	Oct. 14, 2010	ACOUSTIC RESPIRATORY MONITORING SENSOR HAVING MULTIPLE SENSING ELEMENTS
12/904,931	Oct. 14, 2010	ACOUSTIC RESPIRATORY MONITORING SENSOR HAVING MULTIPLE SENSING ELEMENTS
12/904,938	Oct. 14, 2010	ACOUSTIC RESPIRATORY MONITORING SENSOR HAVING MULTIPLE SENSING ELEMENTS
12/904,907	Oct. 14, 2010	ACOUSTIC PATIENT SENSOR
12/904,789	Oct. 14, 2010	ACOUSTIC RESPIRATORY MONITORING SYSTEMS AND METHODS
61/252,062	Oct. 15, 2009	PULSE OXIMETRY SYSTEM WITH LOW NOISE CABLE HUB
61/265,730	Dec. 1, 2009	PULSE OXIMETRY SYSTEM WITH ACOUSTIC SENSOR
12/904,775	Oct. 14, 2010	PULSE OXIMETRY SYSTEM WITH LOW NOISE CABLE HUB
12/905,036	Oct. 14, 2010	PHYSIOLOGICAL ACOUSTIC MONITORING SYSTEM

-continued

App. No.	Filing Date	Title
61/331,087	May 4, 2010	ACOUSTIC RESPIRATION DISPLAY
14/473,831	Aug. 29, 2014	PHYSIOLOGICAL ACOUSTIC MONITORING SYSTEM

[0002] Many of the embodiments described herein are compatible with embodiments described in the above related applications. Moreover, some or all of the features described herein can be used or otherwise combined with many of the features described in the applications listed above.

BACKGROUND OF THE INVENTION

[0003] The “piezoelectric effect” is the appearance of an electric potential and current across certain faces of a crystal when it is subjected to mechanical stresses. Due to their capacity to convert mechanical deformation into an electric voltage, piezoelectric crystals have been broadly used in devices such as transducers, strain gauges and microphones. However, before the crystals can be used in many of these applications they must be rendered into a form which suits the requirements of the application. In many applications, especially those involving the conversion of acoustic waves into a corresponding electric signal, piezoelectric membranes have been used.

[0004] Piezoelectric membranes are typically manufactured from polyvinylidene fluoride plastic film. The film is endowed with piezoelectric properties by stretching the plastic while it is placed under a high-poling voltage. By stretching the film, the film is polarized and the molecular structure of the plastic aligned. A thin layer of conductive metal (typically nickel-copper) is deposited on each side of the film to form electrode coatings to which connectors can be attached.

[0005] Piezoelectric membranes have a number of attributes that make them interesting for use in sound detection, including: a wide frequency range of between 0.001 Hz to 1 GHz; a low acoustical impedance close to water and human tissue; a high dielectric strength; a good mechanical strength; and piezoelectric membranes are moisture resistant and inert to many chemicals.

[0006] Due in large part to the above attributes, piezoelectric membranes are particularly suited for the capture of acoustic waves and the conversion thereof into electric signals and, accordingly, have found application in the detection of body sounds. However, there is still a need for a reliable acoustic sensor, particularly one suited for measuring bodily sounds in noisy environments.

SUMMARY OF THE INVENTION

[0007] An aspect of a physiological acoustic monitoring system receives physiological data from an acoustic sensor, down-samples the data to generate raw audio of breathing sounds and compresses the raw audio. The acoustic monitoring system has an acoustic sensor signal responsive to tracheal sounds in a person. An A/D converter is responsive to the sensor signal so as to generate breathing sound data. A decimation filter and mixer down-samples the breathing sound data to raw audio data. A coder/compressor generates compressed audio data from the raw audio data. A decoder/decompressor decodes and decompresses the compressed audio data into decompressed audio data. The decompressed

audio data is utilized to generate respiration-related parameters in real-time. The compressed audio data is stored and retrieved so as to generate respiration-related parameters in non-real-time. The real-time and non-real-time parameters are compared to verify matching results across multiple monitors.

[0008] Another aspect of a physiological acoustic monitoring system inputs an acoustic sensor signal responsive to tracheal sounds of a person and generates breath tags and a respiration rate. The breath tags represent the acoustic envelope of the tracheal sound, and the respiration rate represents the inverse period of the acoustic envelope. The breath tags and respiration rate have a sufficiently low bandwidth to share a data channel with other physiological parameters. In an embodiment, the acoustic monitor has an acoustic sensor input and an A/D converter that digitizes the sensor input and outputs a digitized sensor signal. A decimation filter and mixer reduces the data rate of the digitized sensor signal and outputs a digitized raw audio. An acoustic parameter processor generates a respiration rate and breath tags in response to the digitized raw audio.

[0009] In various embodiments, the acoustic monitoring system has a coder/compressor that compresses the digitized raw audio to generate compressed audio data, which is stored and retrieved so as to generate respiration-related parameters in non-real-time. A decoder/decompressor decompresses the compressed audio data for the acoustic parameter processor. A D/A converter inputs the digitized raw audio and generates a raw audio analog signal for local playback and listening to the acoustic sensor signal. The compressed audio is transmitted to a remote location as a troubleshooting aid at a remote monitor.

[0010] A further aspect of a physiological acoustic monitoring system inputs a sensor signal responsive to respiratory sounds of a living being, digitizes the sensor signal so as to generate acoustic data, extracts an envelope from the acoustic data, defines an idealized envelope from the extracted envelope, describes the idealized envelope as breath tags and transmits the breath tags over a data channel. In various embodiments, the breath tags are received from the data channel, a reconstructed envelope is synthesized in response to the breath tags and reconstructed acoustic data is generated by filling the envelope with an artificial waveform. In an embodiment, the artificial waveform is white noise.

[0011] An additional aspect of a physiological acoustic monitoring system detects a physiological feature in the extracted envelope and includes the physiological feature in the breath tags. The reconstructed envelope is modified with the detected physiological feature, which may be wheezing or coughing, as examples. The respiratory sounds are approximately reproduced by playing the reconstructed acoustic data on an audio transducer.

[0012] Yet another aspect of a physiological acoustic monitoring system is a sensor signal responsive to respiratory sounds of a living being. An A/D converter digitizes the sensor signal into acoustic data. A parameter generator extracts a respiratory sound envelope from the acoustic data so as to generate a breath tag, which is transmitted over a data channel as a representation of the respiratory sounds. In various embodiments, a remote monitoring station receives the breath tag and a corresponding respiration rate. The monitoring station synthesizes an envelope from the breath tag and the respiration rate and fills the envelope with an

artificial waveform so as to generate reconstituted respiratory sounds. In an embodiment, the artificial waveform is white noise.

[0013] In various other embodiments, a decimation filter and mixer down-samples the acoustic data to raw audio data, a D/A converter converts the raw audio data to a raw audio signal and a speaker that plays the raw audio signal. The parameter generator detects a physiological feature in the extracted envelope and includes the physiological feature in the breath tag. The remote monitor modifies the reconstructed envelope with the detected physiological feature. An audio transducer approximately reproduces the reconstructed acoustic data as compared to the raw audio signal. A compressor generates compressed audio data, which is stored and retrieved so as to generate respiration-related parameters in non-real-time.

BRIEF DESCRIPTION OF THE DRAWINGS

[0014] FIG. 1 is a general block diagram of a physiological acoustic monitoring system;

[0015] FIGS. 2A-B are illustrations of dual channel acoustic sensors;

[0016] FIG. 2A illustrates a neck sensor for physiological measurements and a chest sensor for monaural body sound monitoring;

[0017] FIG. 2B illustrates a dual acoustic sensor for stereo body sound monitoring;

[0018] FIGS. 3A-B are top and bottom perspective views of a body sound sensor;

[0019] FIG. 4 is a general schematic diagram of acoustic and optical sensors and sensor drive elements and a corresponding digital signal processor and I/O drive elements;

[0020] FIG. 5 is a matrix diagram of processor modules and corresponding functionality;

[0021] FIG. 6 is a network diagram for a physiological acoustic monitoring system;

[0022] FIGS. 7A-B are block diagrams of respiration sound generator embodiments;

[0023] FIGS. 8A-C are graphs illustrating breath tag generator embodiments;

[0024] FIG. 9 is a block diagram illustrating a physiological parameter processor embodiment for generating acoustic and optical sensor parameters, breath tags and compressed and raw audio outputs;

[0025] FIGS. 10A-B are a waveform and a block diagram illustrating a respiration beep generator embodiment; and

[0026] FIG. 11 is a block diagram of a physiological acoustic monitoring system for wireless monitoring applications.

DETAILED DESCRIPTION OF THE PREFERRED EMBODIMENTS

[0027] FIG. 1 generally illustrates a physiological acoustic monitoring system 100 embodiment having one or more sensors 110 in communications with one or more processors 130 via a sensor interface 120. The processors 130 both initiate and respond to input/output 150, including audio output 152, displays and alarms 154, communications 156 and controls 158. In an embodiment, the processors 130 are implemented in firmware executing on one or more digital signal processors (DSP), as described with respect to FIGS. 4-5, below. At least a portion of the sensors 110 generate

acoustic signals, which may be directly utilized by the processors 130 or recorded onto or played back from storage media 160 or both.

[0028] The processors 130 include an audio processor 132 that outputs audio waveforms 142, a parameter processor 134 that derives physiological parameters 144 from sensor signals 112 and an acoustic data processor 136 that stores, retrieves and communicates acoustic data 146. Parameters include, as examples, respiration rate, heart rate and pulse rate. Audio waveforms include body sounds from the heart, lungs, gastrointestinal system and other organs. These body sounds may include tracheal air flow, heart beats and pulsatile blood flow, to name a few. Displays allow parameters 144 and acoustic data 146 to be visually presented to a user in various forms such as numbers, waveforms and graphs, as examples. Audio 152 allows audio waveforms to be reproduced through speakers, headphones or similar transducers. Raw audio 122 allows acoustic sensor signals 112 to be continuously reproduced through speakers, headphones or similar transducers, bypassing A/D conversion 120 and digital signal processing 130.

[0029] Storage media 160 allows acoustic data 146 to be recorded, organized, searched, retrieved and played back via the processors 130, communications 156 and audio output 152. Communications 156 transmit or receive acoustic data or audio waveforms via local area or wide area data networks or cellular networks 176. Controls 158 may cause the audio processor 132 to amplify, filter, shape or otherwise process audio waveforms 142 so as to emphasize, isolate, deemphasize or otherwise modify various features of an audio waveform or spectrum. In addition, controls 158 include buttons and switches 178, such as a “push to play” button that initiates local audio output 152 or remote transmission 176 of live or recorded acoustic waveforms.

[0030] As shown in FIG. 1, acoustic data 146 is initially derived from one or more acoustic sensor signals 112, along with, perhaps, other data inputs, such as from optical, blood pressure, EEG and ECG sensors, to name a few. The acoustic data 146 provides audio outputs 142, including audio respiration indicators, described with respect to FIGS. 7-10, below. The acoustic data 146, when analyzed, provides physiological parameters 144 that provide an indication of patient status, such as respiration rate or heart rate. Such analyses may result in visual or audible alerts or alarms 154 that are viewed locally or via notifications transmitted over local or wide area networks 176 to medical staff or other persons. Acoustic data 146 is utilized in real time or stored and retrieved for later use. Acoustic data 146 may be written on various storage media 160, such as a hard drive, and organized for convenient search and retrieval. In an embodiment, acoustic data 146 is advantageously organized on one or more hard drives as virtual magnetic tape so as to more easily manage, search, retrieve and playback acoustic data volumes. Further, the virtual tape volumes and/or the acoustic data itself may be entered into a database and organized as an acoustic library according to various search parameters including patient information, dates, corresponding physiological parameters and acoustic waveform features, to name a few. Applications for a physiological acoustic monitoring system include auscultation of body sounds by medical staff or by audio processors or both; SIDS monitoring; heart distress monitoring including the early detection and mitigation of myocardial infarction and cardiopulmonary arrest, as examples; and elder care, to name a few.

[0031] In an embodiment, sensor sounds 142 may be continuously “piped” to a remote device/listener or a central monitor or both. Listening devices may variously include pagers, cell phones, PDAs, electronic pads or tablets and laptops or other computers to name a few. Medical staff or other remote listeners are notified by the acoustic monitoring system according to flexible pre-programmed protocols to respond to the notification so as to hear breathing sounds, voice, heart sounds or other body sounds.

[0032] FIGS. 2A-B illustrate physiological acoustic monitoring system 200 embodiments each having dual channel acoustic sensors 201, 202 in communications with a physiological monitor 205. As shown in FIG. 2A, a first acoustic sensor 210 is utilized for deriving one or more physiological parameters, such as respiration rate. A second acoustic sensor 220 is utilized to continuously monitor body sounds. In an embodiment, the second acoustic sensor 220 has a different color or shape than the first acoustic sensor 210 so as to identify the sensor as a body sound listening device rather than an acoustic sensing device for determining a physiological parameter. In an embodiment, the body sound sensor 220 is placed over the heart to allow the monitoring of heart sounds or for determination of heart rate. In an embodiment, the body sound sensor 220 generates a signal that bypasses monitor digitization and signal processing so as to allow continuous listening of the unprocessed or “raw” body sounds. In particular, the first acoustic sensor 210 is neck-mounted so as to determine one or more physiological parameters, such as respiration rate. The second acoustic sensor 220 is chest-mounted for monaural heart sound monitoring. As shown in FIG. 2B, first and second acoustic sensors 260, 270 are mounted proximate the same body site but with sufficient spatial separation to allow for stereo sensor reception. In this manner, the listener can more easily distinguish and identify the source of body sounds.

[0033] FIGS. 3A-B illustrate a body sound sensor 300 having acoustic 310, interconnect (not visible) and attachment 350 assemblies. The acoustic assembly 310 has an acoustic coupler 312 and a piezoelectric subassembly 314. The acoustic coupler 312 generally envelops or at least partially covers some or all of the piezoelectric subassembly 314. The piezoelectric subassembly 314 includes a piezoelectric membrane and a support frame (not visible). The piezoelectric membrane is configured to move on the frame in response to acoustic vibrations, thereby generating electrical signals indicative of body sounds. The acoustic coupler 312 advantageously improves the coupling between the acoustic signal measured at a skin site and the piezoelectric membrane. The acoustic coupler 312 includes a contact portion 316 placed against a person's skin.

[0034] Further shown in FIGS. 3A-B, the acoustic assembly 310 communicates with the sensor cable 340 via the interconnect assembly. In an embodiment, the interconnect assembly is a flex circuit having multiple conductors that are adhesively bonded to the attachment assembly 350. The interconnect assembly has a solder pad or other interconnect to interface with the sensor cable 340, and the attachment assembly 350 has a molded strain relief for the sensor cable. In an embodiment, the attachment assembly 350 is a generally circular, planar member having a top side 3511, a bottom side 352, and a center. A button 359 mechanically couples the acoustic assembly 310 to the attachment assembly center so that the acoustic assembly 310 extends from the bottom side 352. The sensor cable 340 extends from one

end of the interconnect and attachment assemblies to a sensor connector at an opposite end so as to provide communications between the sensor and a monitor, as described in further detail with respect to, below. In an embodiment, an adhesive along the bottom side 352 secures the acoustic assembly 310 to a person's skin, such as at a neck, chest, back, abdomen site. A removable backing can be provided with the adhesive to protect the adhesive surface prior to affixing to a person's skin. In other embodiments, the attachment assembly 350 has a square, oval or oblong shape, so as to allow a uniform adhesion of the sensor to a measurement site. In a resposable embodiment, the attachment assembly 350 or portions thereof are removably detachable and attachable to the acoustic assembly 310 for disposal and replacement. The acoustic assembly 310 is reusable accordingly.

[0035] FIG. 4 illustrates acoustic 401 and optical 402 sensors and sensor drive elements 403 and a corresponding digital signal processor 440 and I/O drive elements 404. A multi-acoustic sensor configuration 401 includes a power interface 413, piezo circuits 416 and a piezoelectric membrane 417 corresponding to each sensor head 406, 407. The piezoelectric membrane 417 senses vibrations and generates a voltage in response to the vibrations, as described with respect to the sensor of FIGS. 3A-B, above. The signal generated by the piezoelectric membrane is communicated to the piezo circuit 416, described immediately below, and transmits the signal to the monitor 205 (FIG. 2A) for signal conditioning and processing. The piezo circuit 416 decouples the power supply 413 and performs preliminary signal conditioning. In an embodiment, the piezo circuit 416 includes clamping diodes to provide electrostatic discharge (ESD) protection and a mid-level voltage DC offset for the piezoelectric signal to ride on, to be superimposed on or to be added to. The piezo circuit may also have a high pass filter to eliminate unwanted low frequencies such as below about 100 Hz for breath sound applications, and an op amp to provide gain to the piezoelectric signal. The piezo circuit 416 may also have a low pass filter on the output of the op amp to filter out unwanted high frequencies. In an embodiment, a high pass filter is also provided on the output in addition to or instead of the low pass filter. The piezo circuit may also provide impedance compensation to the piezoelectric membrane, such as a series/parallel combination used to control the signal level strength and frequency of interest that is input to the op amp. In one embodiment, the impedance compensation is used to minimize the variation of the piezoelectric element output. The impedance compensation can be constructed of any combination of resistive, capacitive and inductive elements, such as RC or RLC circuits.

[0036] As shown in FIG. 4, a physiological acoustic monitor 400 embodiment drives and processes signals from a multi-acoustic sensor 401 and an optical sensor 402. The monitor 400 includes one or more acoustic front-ends 421, 422, an analog-to-digital (ND) converter 431, an audio driver 470 and a digital signal processor (DSP) 440. The DSP 440 can comprise a wide variety of data and/or signal processors capable of executing programs for determining physiological parameters from input data. An optical front-end 425, digital-to-analog (D/A) converters 434 and an A/D converter 435 drive emitters 408 and transform resulting composite analog intensity signal(s) from light sensitive detector(s) 409 received via a sensor cable 410 into digital data input to the DSP 440. The acoustic front-ends 421, 422

and A/D converter 431 transform analog acoustic signals from piezoelectric elements 401 into digital data input to the DSP 440. The A/D converter 431 is shown as having a two-channel analog input and a multiplexed digital output to the DSP. In another embodiment, each front-end, communicates with a dedicated single channel A/D converter generating two independent digital outputs to the DSP. An acoustic front-end 421 can also feed an acoustic sensor signal 411 directly into an audio driver 470 for direct and continuous acoustic reproduction of an unprocessed (raw) sensor signal by a speaker, earphones or other audio transducer 462, as described with respect to FIG. 9, below.

[0037] Also shown in FIG. 4, the physiological acoustic monitor 400 may also have an instrument manager 450 that communicates between the DSP 440 and input/output 460. One or more I/O devices 460 have communications with the instrument manager 450 including displays, alarms, user I/O and instrument communication ports. Alarms 466 may be audible or visual indicators or both. The user I/O 468 may be, as examples, keypads, touch screens, pointing devices or voice recognition devices, to name a few. The displays 464 may be indicators, numerics or graphics for displaying one or more of various physiological parameters or acoustic data. The instrument manager 450 may also be capable of storing or displaying historical or trending data related to one or more of parameters or acoustic data.

[0038] Further shown in FIG. 4, the physiological acoustic monitor 400 may also have a "push-to-talk" feature that provides a "listen on demand" capability. That is, a button 468 on the monitor is pushed or otherwise actuated so as to initiate acoustic sounds to be sent to a speaker, handheld device, or other listening device, either directly or via a network. The monitor 400 may also has a "mode selector" button or switch 468 that determines the acoustic content provided to a listener, either local or remote. These controls may be actuated local or at a distance by a remote listener. In an embodiment, push on demand audio occurs on an alarm condition in lieu of or in addition to an audio alarm. Controls 468 may include output filters like on a high quality stereo system so that a clinician or other user could selectively emphasize or deemphasize certain frequencies so as to hone-in on particular body sounds or characteristics.

[0039] In various embodiments, the monitor 400 may be one or more processor boards installed within and communicating with a host instrument. Generally, a processor board incorporates the front-end, drivers, converters and DSP. Accordingly, the processor board derives physiological parameters and communicates values for those parameters to the host instrument. Correspondingly, the host instrument incorporates the instrument manager and I/O devices. A processor board may also have one or more microcontrollers (not shown) for board management, including, for example, communications of calculated parameter data and the like to the host instrument. A processor board embodiment is described with respect to FIG. 9, below.

[0040] Communications 469 may transmit or receive acoustic data or audio waveforms via local area or wide area data networks or cellular networks. Controls may cause the audio processor to amplify, filter, shape or otherwise process audio waveforms so as to emphasize, isolate, deemphasize or otherwise modify various features of the audio waveform or spectrum. In addition, switches, such as a "push to play" button can initiate audio output of live or recorded acoustic data. Controls may also initiate or direct communications.

[0041] FIG. 5 illustrates processor modules 500 that may execute on a DSP 440 (FIG. 4) and/or instrument manager 450 (FIG. 4) in various physiological acoustic monitoring system embodiments and the corresponding functionality of these modules. Module functionality includes processing sensor input 510, storage 520 and playback 530 of acoustic data, acoustic data analysis 540, communication of acoustic data and derived physiological parameters 550 and specific applications 560. Sensor input 510 related modules include dynamic range 512 and noise reduction 513. Dynamic range 512 functionality is described with respect to the processor board codec and FIG. 9, below. Storage 520 related modules include virtual tape 523 and database 524 functionality, described with respect to FIG. 6, below. Playback 530 functionality includes audio filters 532, sound reproduction 534 including mono/stereo/quadrasonic 533 modes and auscultation 535 enhancement. Analysis 540 related modules include audio parameters 542, multi-sensor parameters 543 and corresponding alarms 544. Communications 550 related modules include cellular 553, wireless 554 and network 555 modes. Wireless is described with respect to FIG. 11, below, and cellular 553 and networks 555 are described with respect to FIG. 6, below. Applications 560 include elder care 561 and SIDS 562, described with respect to FIG. 12, below.

[0042] FIG. 6 illustrates a physiological acoustic monitoring system 600 embodiment having a shared or open network architecture interconnecting one or more physiological monitors 610, monitoring stations 620 and mass storage 660. This interconnection includes proximity wireless devices 612 in direct wireless communication with a particular physiological monitor 610; local wireless devices 632 in communications with the monitors 610 via a wireless LAN 630; and distant wired or wireless devices 642, 652 in communications with the monitors 610 via WAN, such as Internet 640 or cellular networks 650. Communication devices may include local and remote monitoring stations 620 and wired or wireless communications and/or computing devices including cell phones, lap tops, pagers, PDAs, tablets and pads, to name a few. Physiological information is transmitted/received directly to/from end users over LAN or WAN. End users such as clinicians may carry wireless devices 632 in communications with the WLAN 630 so as to view in real-time physiological parameters or listen to audio data and waveforms on demand or in the event of an alarm or alert.

[0043] The network server 622 in certain embodiments provides logic and management tools to maintain connectivity between physiological monitors, clinician notification devices and external systems, such as EMRs. The network server 622 also provides a web based interface to allow installation (provisioning) of software related to the physiological monitoring system, adding new devices to the system, assigning notifiers to individual clinicians for alarm notification, escalation algorithms in cases where a primary caregiver does not respond to an alarm, interfaces to provide management reporting on alarm occurrences and internal journaling of system performance metrics such as overall system uptime. The network server 622 in certain embodiments also provides a platform for advanced rules engines and signal processing algorithms that provide early alerts in anticipation of a clinical alarm.

[0044] As shown in FIG. 6, audio data and corresponding audio files are advantageously stored on virtual tape 662,

which provides the storage organization of tape cartridges without the slow, bulky, physical storage of magnetic tape and the corresponding human-operator intervention to physically locate and load physical cartridges into an actual tape-drive. A virtual tape controller 662 emulates standard tape cartridges and drives on modern, high capacity disk drive systems, as is well-known in the art. Accordingly, virtual "audio tapes" appear the same as physical tapes to applications, allowing the use of many existing cartridge tape storage, retrieval and archival applications. Further, while the upper-limit of a physical tape cartridge may be a few hundred megabytes, a virtual tape server 662 can be configured to provide considerably larger "tape" capacity. Mount-time is near-zero for a virtual tape and the data is available immediately. Also, while traditional physical tape systems have to read a tape from the beginning, moving sequentially through the files on the tape, a virtual drive can randomly access data at hard-disk speeds, providing tape I/O at disk access speeds.

[0045] Additionally shown in FIG. 6, a sound processing firmware module of certain embodiments accesses a database 670 of sound signatures 660 and compares the received signal with the entries in the database to characterize or identify sounds in the received signal. In another embodiment, the sound processing module generates and/or accesses a database 670 of sound signatures specific to a patient, or specific to a particular type of patient (e.g., male/female, pediatric/adult/geriatric, etc.). Samples from a person may be recorded and used to generate the sound signatures. In some embodiments, certain signal characteristics are used to identify particular sounds or classes of sounds. For example, in one embodiment, signal deviations of relatively high amplitude and or sharp slope may be identified by the sound processing module. Sounds identified in various embodiments by the sound processing module include, but are not limited to, breathing, speech, choking, swallowing, spasms such as larynx spasms, coughing, gasping, etc.

[0046] Once the sound processing module characterizes a particular type of sound, the acoustic monitoring system can, depending on the identified sound, use the characterization to generate an appropriate response. For example, the system may alert the appropriate medical personnel to modify treatment. In one embodiment, medical personnel may be alerted via an audio alarm, mobile phone call or text message, or other appropriate means. In one example scenario, the breathing of the patient can become stressed or the patient may begin to choke due to saliva, mucosal, or other build up around an endotracheal tube. In an embodiment, the sound processing module can identify the stressed breathing sounds indicative of such a situation and alert medical personnel to the situation so that a muscle relaxant medication can be given to alleviate the stressed breathing or choking.

[0047] According to some embodiments, acoustic sensors described herein can be used in a variety of other beneficial applications. For example, an auscultation firmware module may process a signal received by the acoustic sensor and provide an audio output indicative of internal body sounds of the patient, such as heart sounds, breathing sounds, gastrointestinal sounds, and the like. Medical personnel may listen to the audio output, such as by using a headset or speakers. In some embodiments the auscultation module allows medical personnel to remotely listen for patient

diagnosis, communication, etc. For example, medical personnel may listen to the audio output in a different room in a hospital than the patient's room, in another building, etc. The audio output may be transmitted wirelessly (e.g., via Bluetooth, IEEE 802.11, over the Internet, etc.) in some embodiments such that medical personnel may listen to the audio output from generally any location.

[0048] FIGS. 7A-B illustrate sound processing embodiments **701**, **702** for generating an audio output for an acoustic sensor. As shown in FIG. 7A, in one embodiment, acoustic sensor data is A/D converted **710**, down-sampled with a decimation filter **720** and compressed **730**. The compressed audio data **732** is transmitted to a monitor, which decompresses the data **740** and outputs it to a speaker **742** or similar audio transducer. However, compressed audio data **732** from a physiological acoustic sensor has too high a bit rate to transmit over monitor data channels shared with other physiological processors or patient networks shared by multiple patient monitors all communicating physiological parameters, waveforms and other real-time medical data. Acoustic sensor data rates are described in further detail with respect to FIG. 9, below.

[0049] As shown in FIG. 7B, an envelope-based sound processing **702** embodiment advantageously allows respiration-related acoustic data to be transmitted at significantly reduced data rates compared with data compression so as to allow shared transmission over monitor data channels (**990** FIG. 9) and patient networks. Respiration-related acoustic data is A/D converted **710** and input to an envelope detector **750**. The detected envelopes are idealized and represented by a small number set or "tag" corresponding to each breath. In an embodiment, a breath tag represents the time-of-occurrence of the breath envelope peak for each inspiration and expiration cycle. These breath tags **760** are then transmitted over standard multiple parameter patient monitor data channels and/or patient networks. At the receiving end, a patient monitor, multiple patient monitoring system or like monitoring device synthesizes the envelopes **770** from the breath tags **760** according to the respiration rate (RR). The envelopes **770** are then filled with white noise **780** so as to simulate the original respiration acoustic data **782**.

[0050] FIGS. 8A-C further illustrate envelope processing for acoustic sensor data. FIG. 8A illustrates a representative acoustic signal **801** derived by a neck sensor detecting vibrations resulting from tracheal air flow during respiration. A breath sound **810** has an envelope **820** "pulse" corresponding to either inhalation or exhalation. An envelope detector **750** (FIG. 7B) generates breath tags that numerically describe the envelope **820**. As shown in FIG. 8B, in one embodiment, breath tags describe an idealized envelope **830**. For example, a breath tag may be an amplitude value and a duration value for each idealized pulse. In other embodiments, a breath tag may include leading/trailing slope values for a pulse **830**. As shown in FIG. 8C, in other embodiments, breath tags include detected envelope features **842**, **843**, **844** that are characteristic of known acoustically-related phenomena such as wheezing or coughing, as examples. At a receiving device, envelop synthesis **770** (FIG. 7B) reproduces an envelope **830**, **840** and fills the envelope with an artificial waveform, such as white noise. This reconstructed or simulated breath signal is then output to a speaker or similar device. In other embodiments, breath tags are transmitted over a network to a remote device, which reconstructs breathing waveforms from the breath tags in like manner.

[0051] In various other embodiments, acoustic breathing waveforms are detected by an acoustic sensor, processed, transmitted and played on a local or remote speaker or other audio output from actual (raw) data, synthetic data and artificial data. Actual data may be compressed, but is a nearly complete or totally complete reproduction of the actual acoustic sounds at the sensor. Synthetic data may be a synthetic version of the breathing sound with the option of the remote listener to request additional resolution. Artificial data may simulate an acoustic sensor sound with minimal data rate or bandwidth, but is not as clinically useful as synthetic or actual data. Artificial data may be, for example, white noise bursts generated in sync with sensed respiration. Synthetic data is something between actual data and artificial data, such as the acoustic envelope process described above that incorporates some information from the actual sensor signal. In an embodiment breath sounds are artificially hi/lo frequency shifted or hi/lo volume amplified to distinguish inhalation/exhalation. In an embodiment, dual acoustic sensors placed along the neck are responsive to the relative time of arrival of tracheal sounds so as to distinguish inhalation and exhalation in order to appropriately generate the hi/lo frequency shifts. Raw and compressed acoustic respiration data is described with respect to FIG. 9, below. Artificial data "breath beeps" are described with respect to FIGS. 10A-B, below.

[0052] FIG. 9 illustrates a processor board **900** embodiment of an acoustic monitoring system that generates both optical and acoustic data. An optical portion has D/A converters **958** responsive to emitter drives **954** and an emitter control **950** so as to alternately activate optical sensor **902** LEDs of multiple wavelengths so as to illuminate blood perfused tissue. An A/D converter **960** and demodulator **964** are responsive to sensor **902** detectors so as to generate plethysmographic data **968** to a digital signal processor (DSP) **980**. Corresponding blood parameter algorithms **970** generate blood parameter outputs **972**, such as oxygen saturation (SpO₂), to a data channel **990**.

[0053] Also shown in FIG. 9, an acoustic portion has an A/D converter **910**, a decimation filter and mixer **920**, a coder/compressor **930** and a decoder/decompressor **935** so as to generate acoustic data to the DSP **980**. The A/D **910**, decimation filter/mixer **920** and a D/A converter **925** are responsive to an acoustic sensor **901** so as to generate an analog "raw" audio **909** output. In an embodiment, the A/D **910** is a 48 KHz, 16-bit, 2-channel variable gain device that provides higher resolution at lower signal amplitudes and lower resolution and higher signal amplitudes. In an embodiment, the decimation filter/mixer generates 2 KHz, 32-bit (64 Kbps) digitized raw audio **922**. Advantageously, the raw audio **909** is routed to a proximate amplifier/speaker **122** (FIG. 1). The digitized raw audio **922** is also input to the coder/compressor **930**. A 3:1 (approx.) compression generates a 20 Kbps compressed (digitized) audio **908** output. The compressed audio **908** is immediately input into a decoder/decompressor **935** for use by acoustic algorithms **940** to generate respiration rate (RR) and breath tag **942** outputs to a data channel **990**, as described above, among other acoustic-related parameters. Advantageously, the compression and immediate decompression of the digitized raw audio **922** provides a compressed audio output **908** that can be stored and retrieved for accurate off-line reproduction and troubleshooting of device behavior. Also, the compressed audio output **908** can be advantageously transmitted via

Wi-Fi or other communication links to remote locations for processing and patient analysis.

[0054] FIGS. 10A-B illustrate a “respiration beep” embodiment 1001 for communicating reduced-rate respiration data over relatively low bandwidth monitor data channels and patient networks. As shown in FIG. 10A, in some situations, acoustic respiration data 1000 presents an inspiration (I) 1010 pulse relatively closely followed by an expiration (E) 1020 pulse, where each I/E pair is separated by a relatively longer pulseless interval. That is, these I/E pairs are relatively easily distinguished. As such, I/E pairs can be transmitted as simply time-of-occurrence values.

[0055] As shown in FIG. 10B, at an inspiration time 1062, a high (HI) frequency tone 1064 is generated. At an expiration time 1062, a low (LO) frequency tone 1064 is generated. A mixer 1050 combines colored noise 1042 with the HI/LO tones 1064 to generate higher-pitched followed by lower-pitched noise pulses representative of the original acoustic waveform 1000. These respiration “beeps” are roughly analogous to pulse oximeter-generated “beeps” that coincide with optical sensor detected arterial blood pulses. In an advantageous embodiment, a processor board 900 (FIG. 9) having optical and acoustic sensors generates simultaneously occurring respiration beeps and pulse beeps, where the pulse beep tone is easily distinguished from the respiration beep HI/LO noise pulses. These combined pulse/respiration beeps advantageously allow a care provider to “monitor” a patient’s respiration and pulse by sound alone.

[0056] FIG. 11 illustrates a wireless physiological acoustic monitor 1100 embodiment, which is particular advantageous for out-patient applications, such as sudden infant death syndrome (SIDS) prevention and elder care. The monitor 1100 has a sensor section 1101 and a remote section 1102. The sensor section 1101 has a sensor 1110, a sensor interface 1120 and a communications element 1130. In an embodiment, the sensor 1110 is an adhesive substrate integrated with a piezoelectric assembly and interconnect cable, such as described with respect to FIGS. 3A-B, above. The sensor interface 1120 provides power to and receives the sensor signal from the sensor piezo circuit, as described with respect to FIG. 4, above. The wireless communications element 1130 receives the sensor signal from the sensor interface 1120 and transmits the signal to the corresponding communications element 1140 in the remote section 1102, which provides an amplified sensor signal sufficient to drive a small speaker. In an embodiment, the communications link 1160 conforms with IEEE 802.15 (Bluetooth).

[0057] A physiological acoustic monitoring system has been disclosed in detail in connection with various embodiments. These embodiments are disclosed by way of examples only and are not to limit the scope of the claims that follow. One of ordinary skill in art will appreciate many variations and modifications.

1. (canceled)

2. A method for simulating physiological sounds of a patient responsive to measurements from one or more sensors attached to the patient, the method comprising:

- detecting a first portion in an acoustic signal corresponding to a physiological process of inspiration;
- detecting a second portion in the acoustic signal corresponding to a physiological process of expiration;
- generating a first sound corresponding to the inspiration process based on the detected first portion;

- generating a second sound including a different characteristic than the first sound corresponding to the expiration process based on the detected second portion;
- mixing the first sound and the second sound with a noise sound; and
- output the mixed sound corresponding to physiological sounds of respiration.

3. The method of claim 2, further comprising adding a third sound corresponding to a pulse detected from an optical sensor to the mixed sound, wherein the third sound is different than the first sound and the second sound.

4. The method of claim 2, further comprising transmitting breath tags corresponding to the first portion and the second portion over a network.

5. The method of claim 2, wherein the different characteristic comprises a pitch.

6. The method of claim 2, wherein the acoustic signal is received from an acoustic sensor comprising a piezoelectric element configured to detect electrical signals.

7. The method of claim 2, further comprising transmitting the mixed sound over a network.

8. The method of claim 2, wherein the acoustic signal comprises two separate acoustics signals received respectively from a first acoustic sensor and a second acoustic sensor, the first acoustic sensor at a first location on a neck of a patient and the second sensor at a different location than the first location.

9. The method of claim 2, further comprising detecting a pulse from a third acoustic signal received from an acoustic sensor attached near a heart of the patient.

10. The method of claim 9, further comprising adding a third sound corresponding to the pulse detected to the mixed sound, wherein the third sound is different than the first sound and the second sound.

11. A system for simulating physiological sounds of a patient responsive to measurements from one or more sensors attached to the patient, the method comprising:

- one or more acoustic sensors configured to detect acoustic signals; and

- one or more hardware processors configured to:

- detect a first time of occurrence of a physiological process of inspiration from the acoustic signals;
- detect a second time of occurrence of a physiological process of expiration from the acoustic signals;
- generating a first sound based on the detected first time of occurrence of the physiological process of inspiration;
- generating a second sound based on the detected second time of occurrence of the physiological process of expiration;
- mixing the first sound and the second sound with a noise sound; and
- output the mixed sound corresponding to physiological sounds of respiration including the physiological process of inspiration and the physiological process of expiration.

12. The system of claim 11, further comprising an optical sensor configured to detect a plethysmograph signal and the one or more hardware processors are configured to add a third sound corresponding to a pulse detected from the plethysmograph signal to the mixed sound, wherein the third sound is different than the first sound and the second sound.

13. The system of claim **11**, wherein the one or more hardware processors are further configured to transmit breath tags corresponding to the first time and the second time over a network.

14. The system of claim **11**, wherein the different characteristic comprises a pitch.

15. The system of claim **11**, wherein the one or more acoustic sensors comprise a piezoelectric element configured to detect electrical signals.

16. The system of claim **11**, wherein the one or more hardware processors are further configured to transmit the mixed sound over a network.

17. The system of claim **11**, wherein the one or more acoustic sensors comprise a first acoustic sensor and a second acoustic sensor, the first acoustic sensor at a first location on a neck of a patient and the second sensor at a different location than the first location.

18. The system of claim **17**, wherein the one or more acoustic sensors comprise a third acoustic sensor attached near a heart of the patient.

19. The system of claim **18**, wherein the one or more hardware processors are further configured to add a third sound corresponding to the pulse detected to the mixed sound, wherein the third sound is different than the first sound and the second sound.

20. A system for simulating physiological sounds of a patient responsive to measurements from one or more sensors attached to the patient, the method comprising:

means for detecting a physiological process of inspiration from acoustic signals;

means for detecting a physiological process of expiration from the acoustic signals;

means for generating sounds corresponding to the detected physiological process of inspiration and the physiological process of expiration; and

means for mixing the first sound and the second sound with a noise sound.

* * * * *

专利名称(译)	生理声学监测系统		
公开(公告)号	US20170007198A1	公开(公告)日	2017-01-12
申请号	US15/184951	申请日	2016-06-16
[标]申请(专利权)人(译)	梅西莫股份有限公司		
申请(专利权)人(译)	Masimo公司		
当前申请(专利权)人(译)	Masimo公司		
[标]发明人	AL ALI AMMAR LEE SUNG UK		
发明人	AL-ALI, AMMAR LEE, SUNG UK		
IPC分类号	A61B7/00 A61B5/08 A61B5/024 A61B7/04 A61B5/00		
CPC分类号	A61B7/003 A61B7/04 A61B5/7278 A61B5/7415 A61B5/02416 A61B5/746 A61B5/6822 A61B5/0816 A61B5/7232 A61B5/742 A61B5/0022 A61B5/0004 A61B5/0803 A61B5/082 A61B5/0823 A61B5/7225 A61B5/7405 G10L19/00 A61B5/725		
优先权	61/547007 2011-10-13 US 61/252099 2009-10-15 US 61/391098 2010-10-08 US		
其他公开文献	US10098610		
外部链接	Espacenet USPTO		

摘要(译)

生理声学监测系统从声学传感器接收生理数据，对数据进行下采样以生成呼吸声音的原始音频并压缩原始音频。声学监测系统具有响应于人的气管声音的声学传感器信号。A/D转换器响应传感器信号以产生呼吸声数据。抽取滤波器和混频器将呼吸声音数据下采样到原始音频数据。编码器/压缩器从原始音频数据生成压缩音频数据。解码器/解压缩器将压缩的音频数据解码和解压缩成解压缩的音频数据。解压缩的音频数据用于实时生成呼吸相关参数。存储和检索压缩的音频数据，以便非实时地生成与呼吸相关的参数。比较实时和非实时参数以验证跨多个监视器的匹配结果。

