



US 20160262629A1

(19) **United States**

(12) **Patent Application Publication**  
**ABREU**

(10) **Pub. No.: US 2016/0262629 A1**

(43) **Pub. Date: Sep. 15, 2016**

(54) **DEVICES, APPARATUSES, SYSTEMS, AND METHODS FOR MEASURING TEMPERATURE OF AN ABTT TERMINUS**

**Publication Classification**

(71) Applicant: **GEELUX HOLDINGS, LTD.**, Tortola (VG)

(51) **Int. Cl.**  
*A61B 5/01* (2006.01)  
*A61B 5/1172* (2006.01)  
*A61B 5/00* (2006.01)

(72) Inventor: **Marcio Marc ABREU**, Bridgeport, CT (US)

(52) **U.S. Cl.**  
CPC ..... *A61B 5/01* (2013.01); *A61B 5/0079* (2013.01); *A61B 5/0042* (2013.01); *A61B 5/7425* (2013.01); *A61B 5/0008* (2013.01); *A61B 5/1172* (2013.01); *A61B 5/6898* (2013.01); *A61B 5/0013* (2013.01); *A61B 2562/16* (2013.01); *A61B 2562/0247* (2013.01); *A61B 2562/08* (2013.01); *A61B 2562/0271* (2013.01); *A61B 2090/065* (2016.02)

(73) Assignee: **GEELUX HOLDINGS, LTD.**, Tortola (VG)

(21) Appl. No.: **15/066,779**

(22) Filed: **Mar. 10, 2016**

**Related U.S. Application Data**

(60) Provisional application No. 62/131,131, filed on Mar. 10, 2015.

(57) **ABSTRACT**

Apparatuses, systems, devices, mechanisms, and methods are used to locate an ABTT terminus and then to measure the temperature of the ABTT terminus.

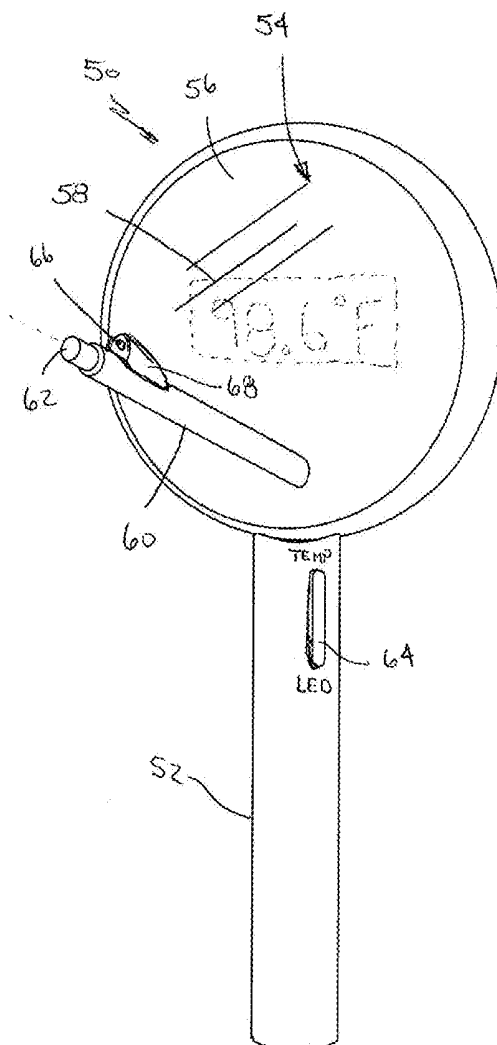


FIG. 1

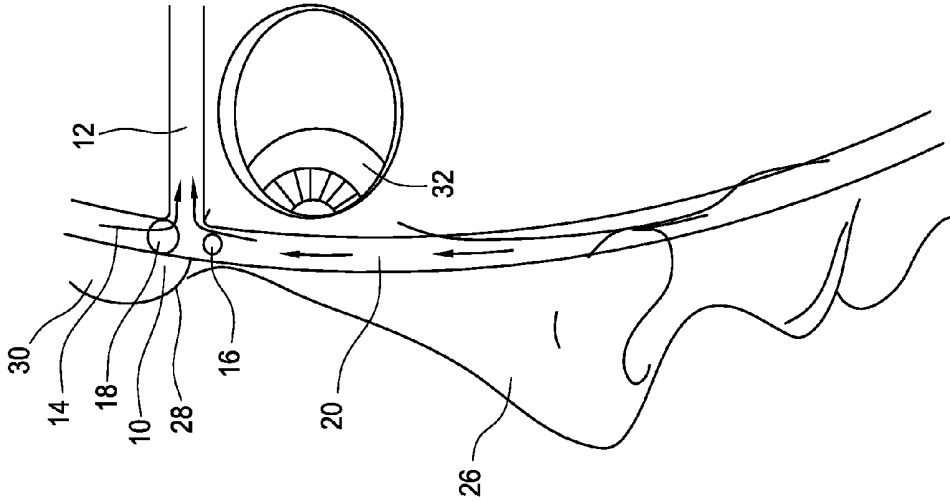
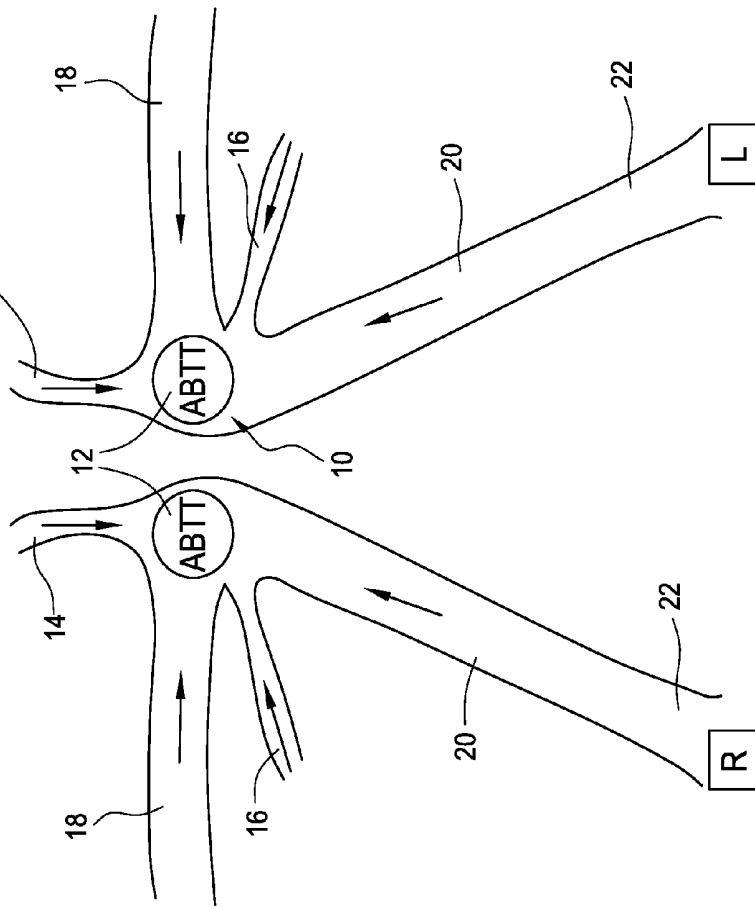


FIG. 2

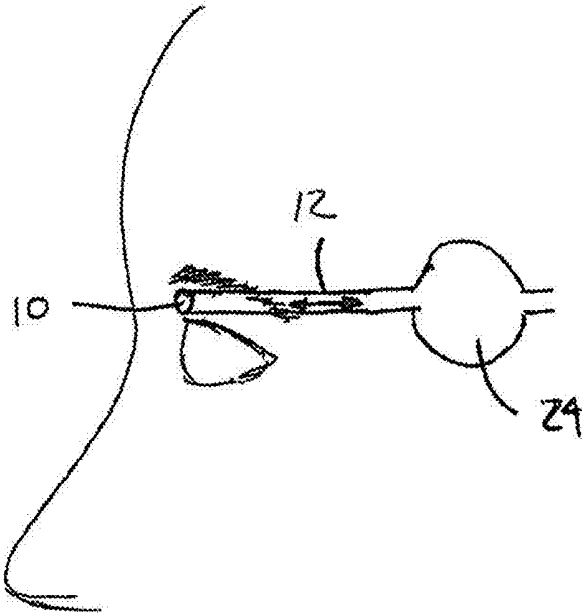


FIG. 3

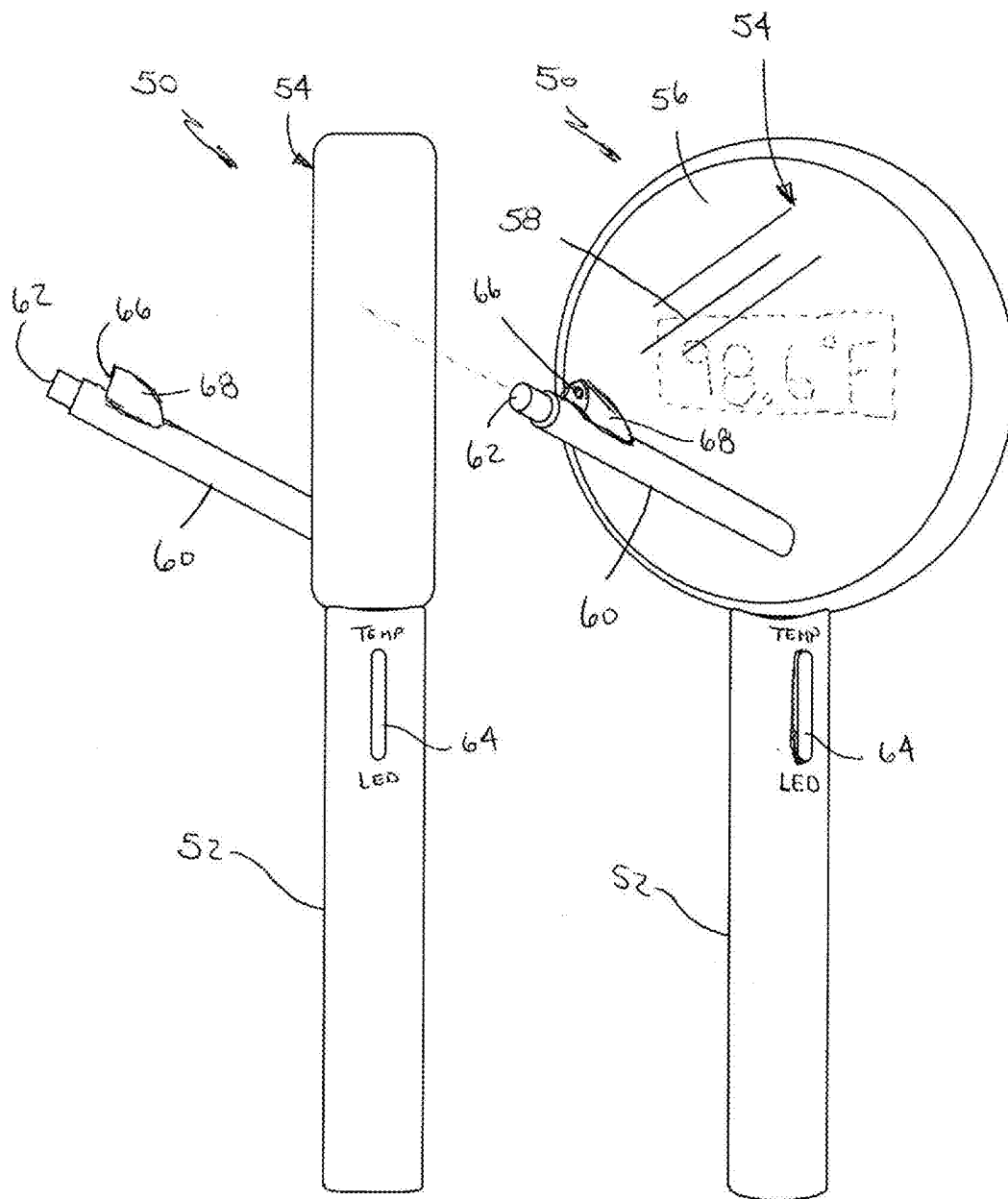


FIG. A

FIG. 5

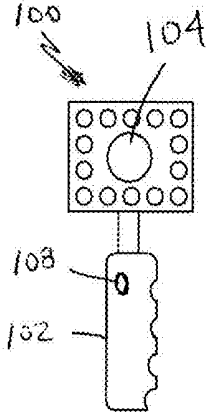


FIG. 6

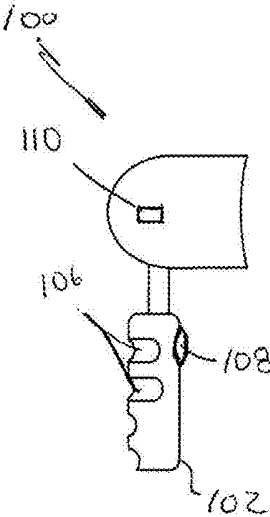


FIG. 7

FIG. 7A

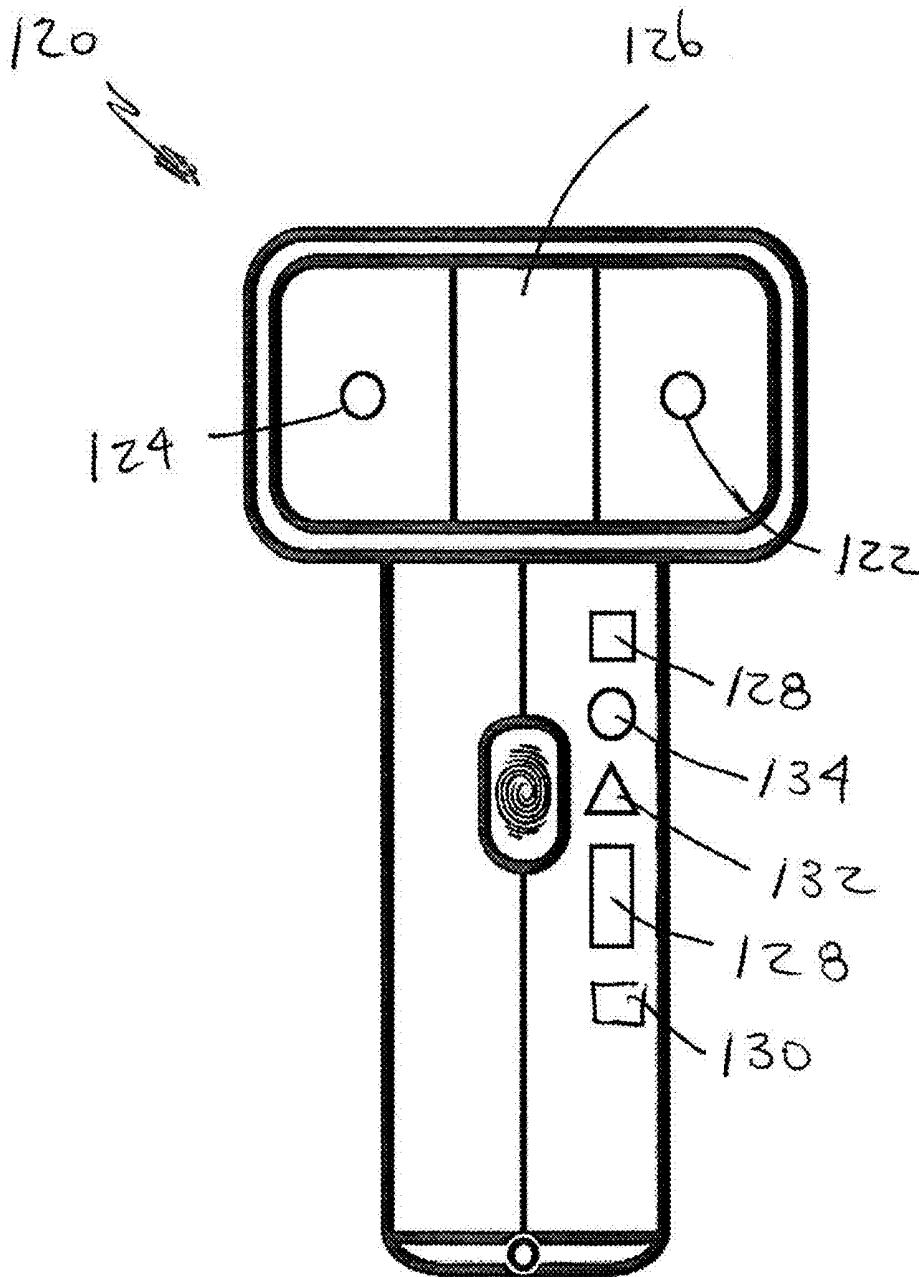


FIG. 7B

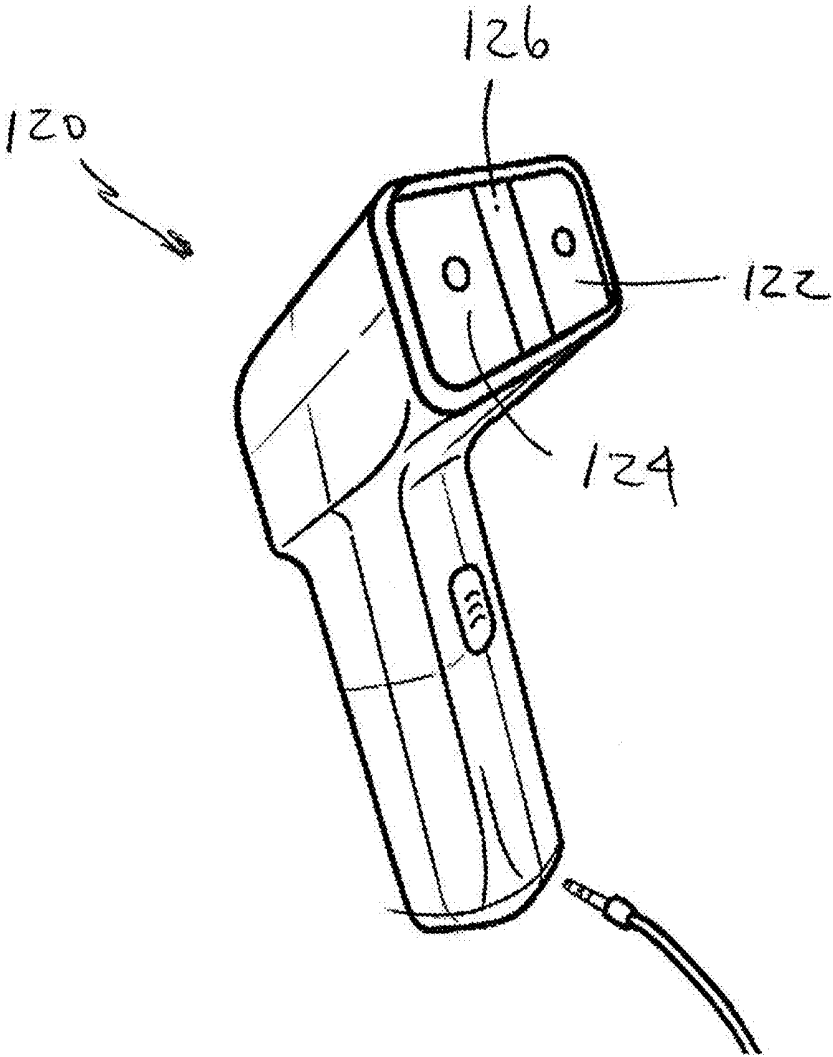


FIG. 7C

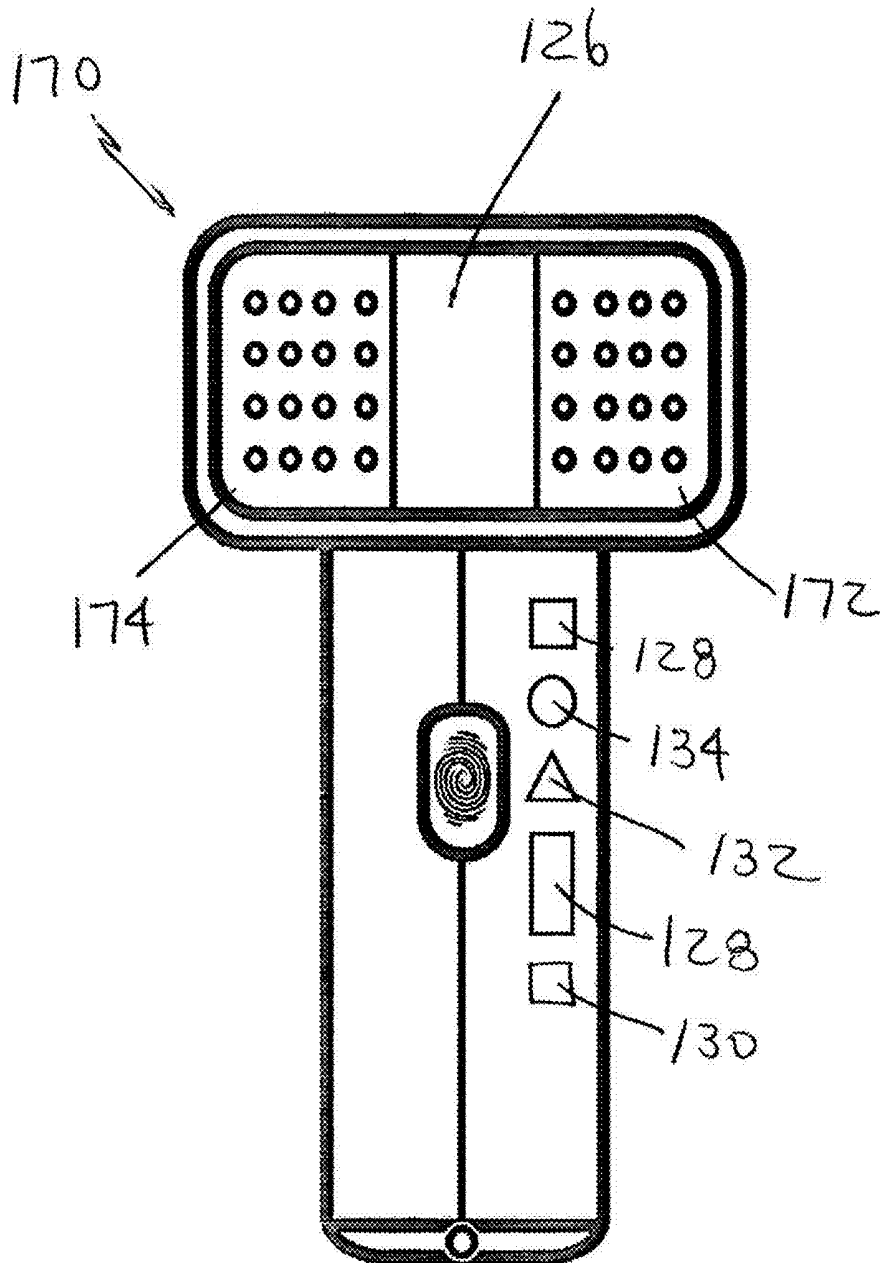


FIG. 7D

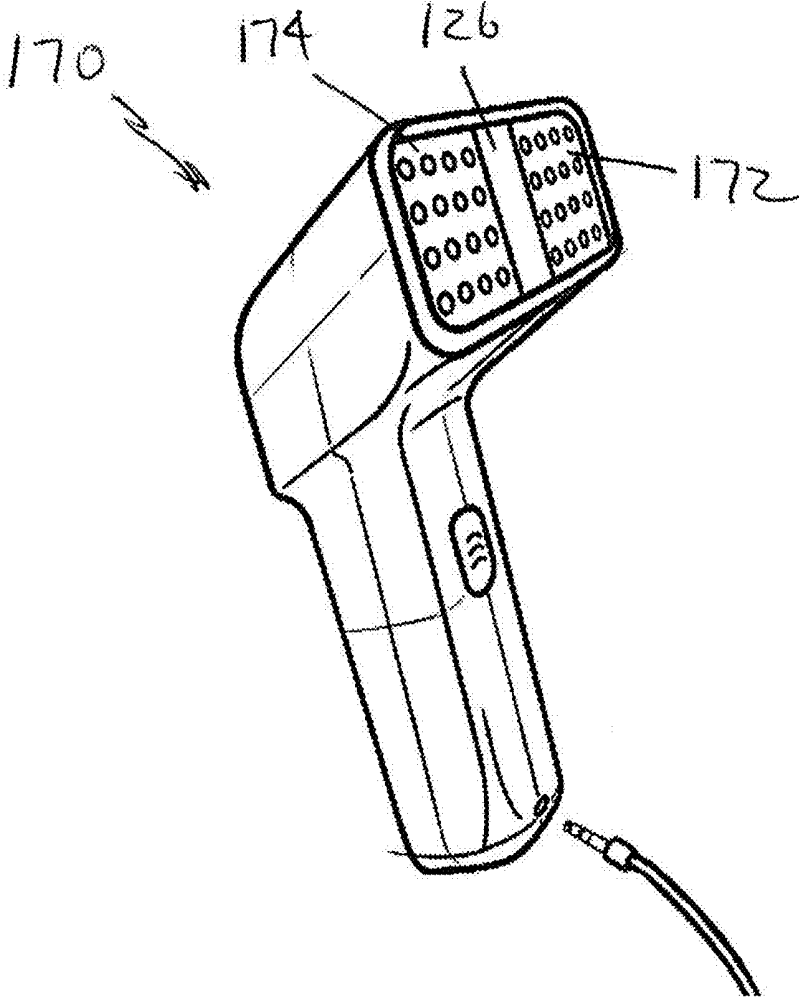


FIG. 7E

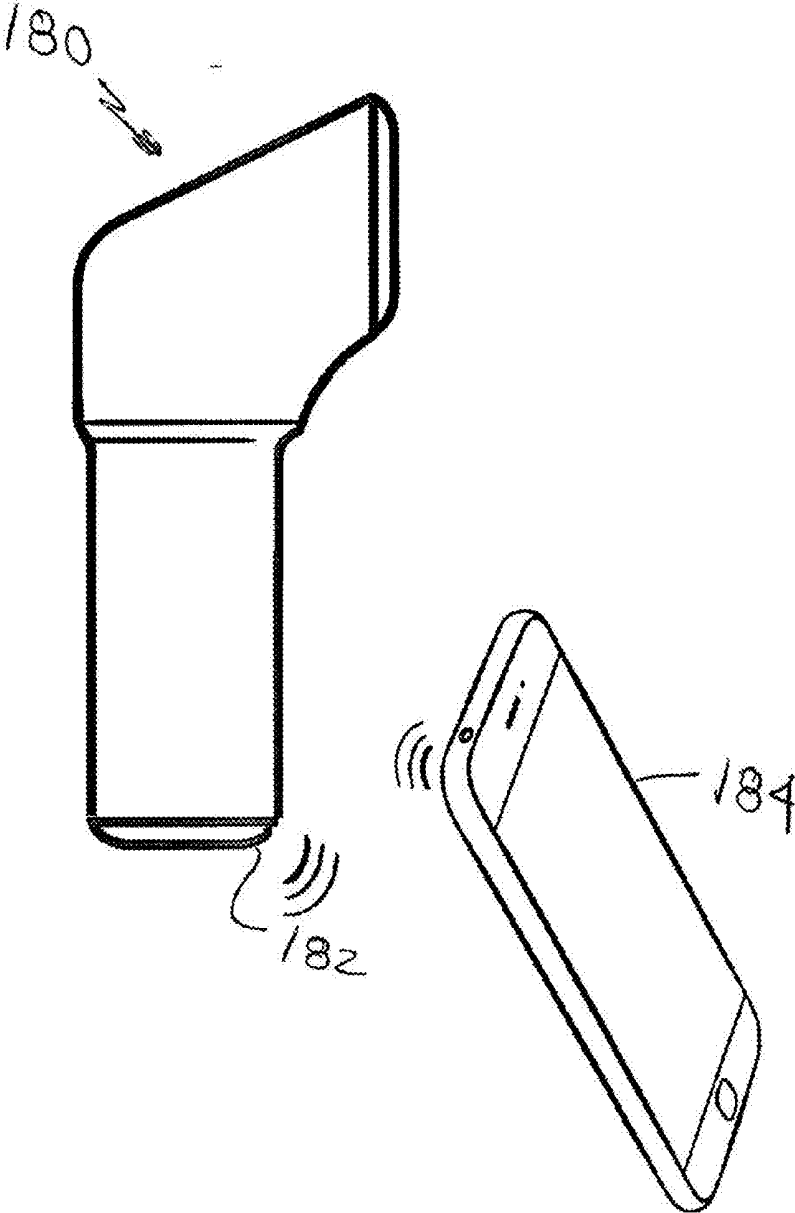


FIG. 7F

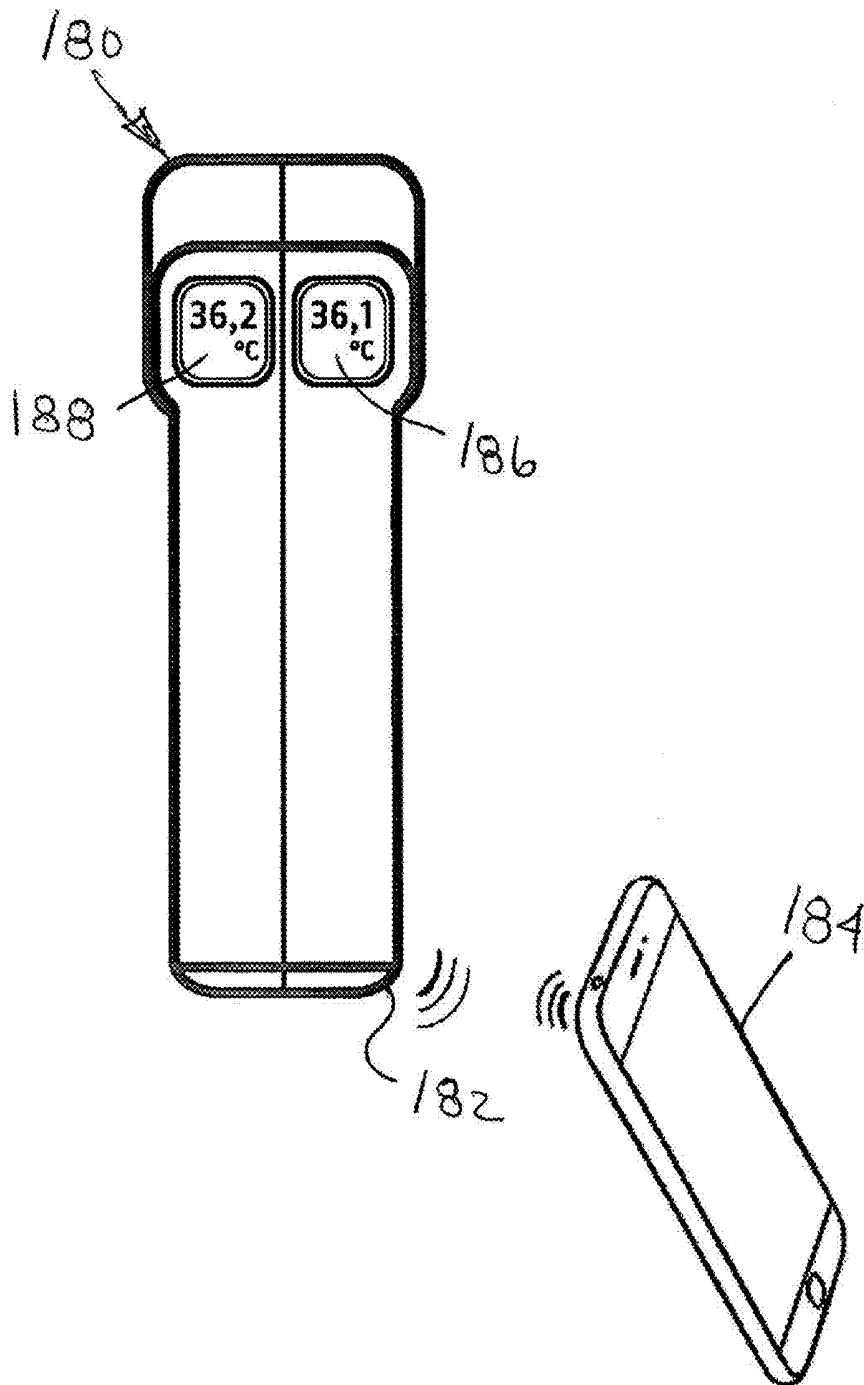
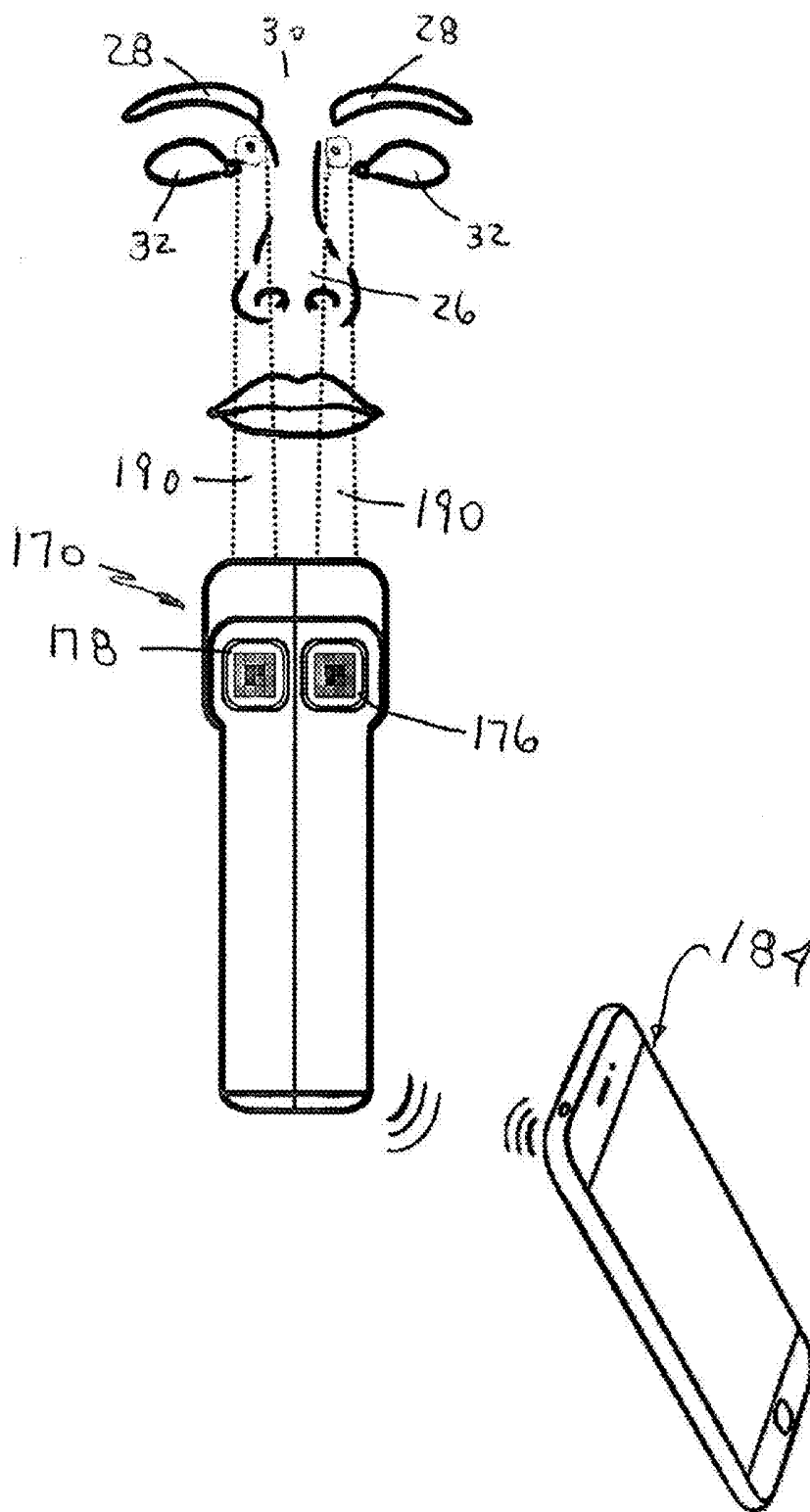


FIG. 7G



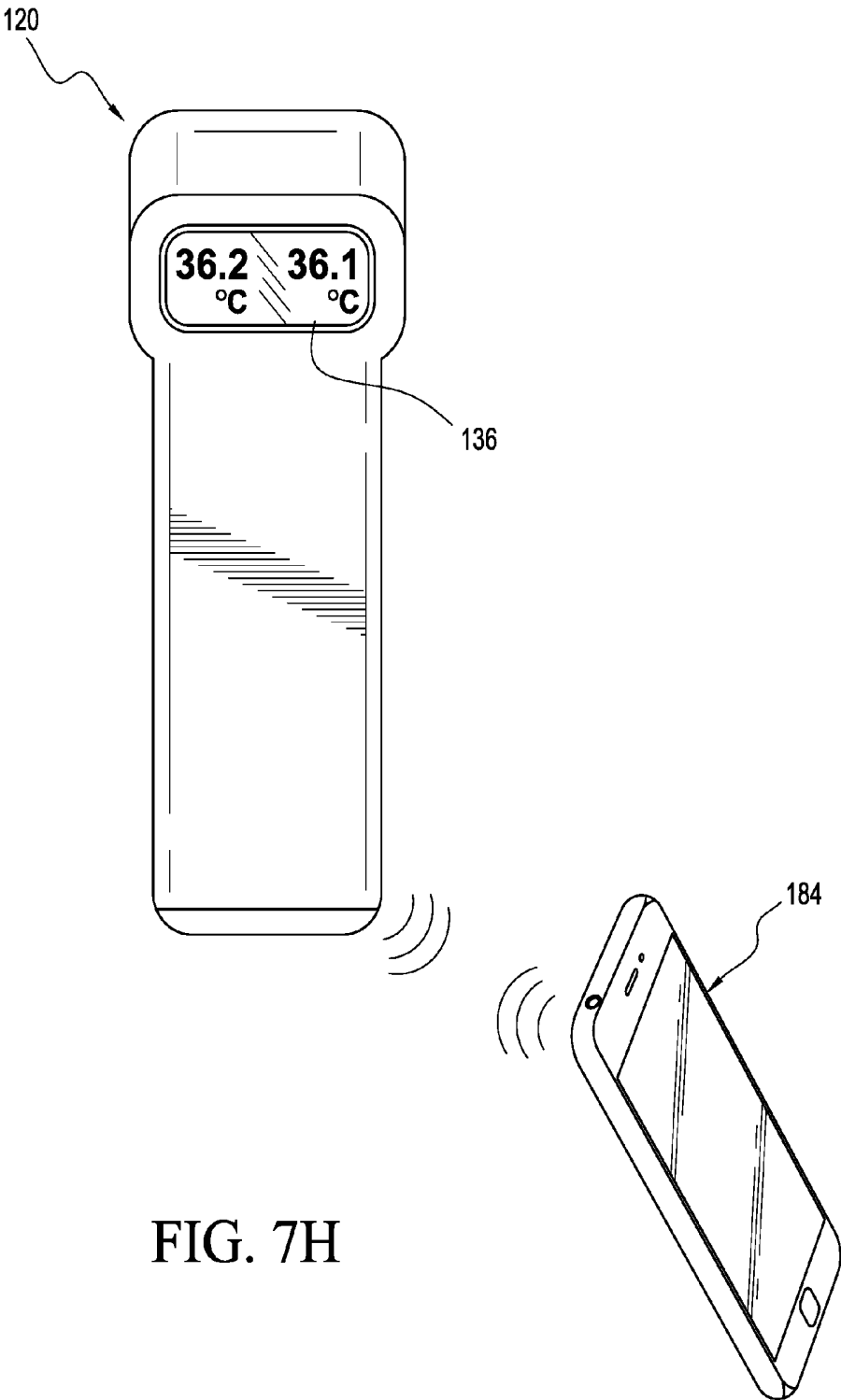


FIG. 7H

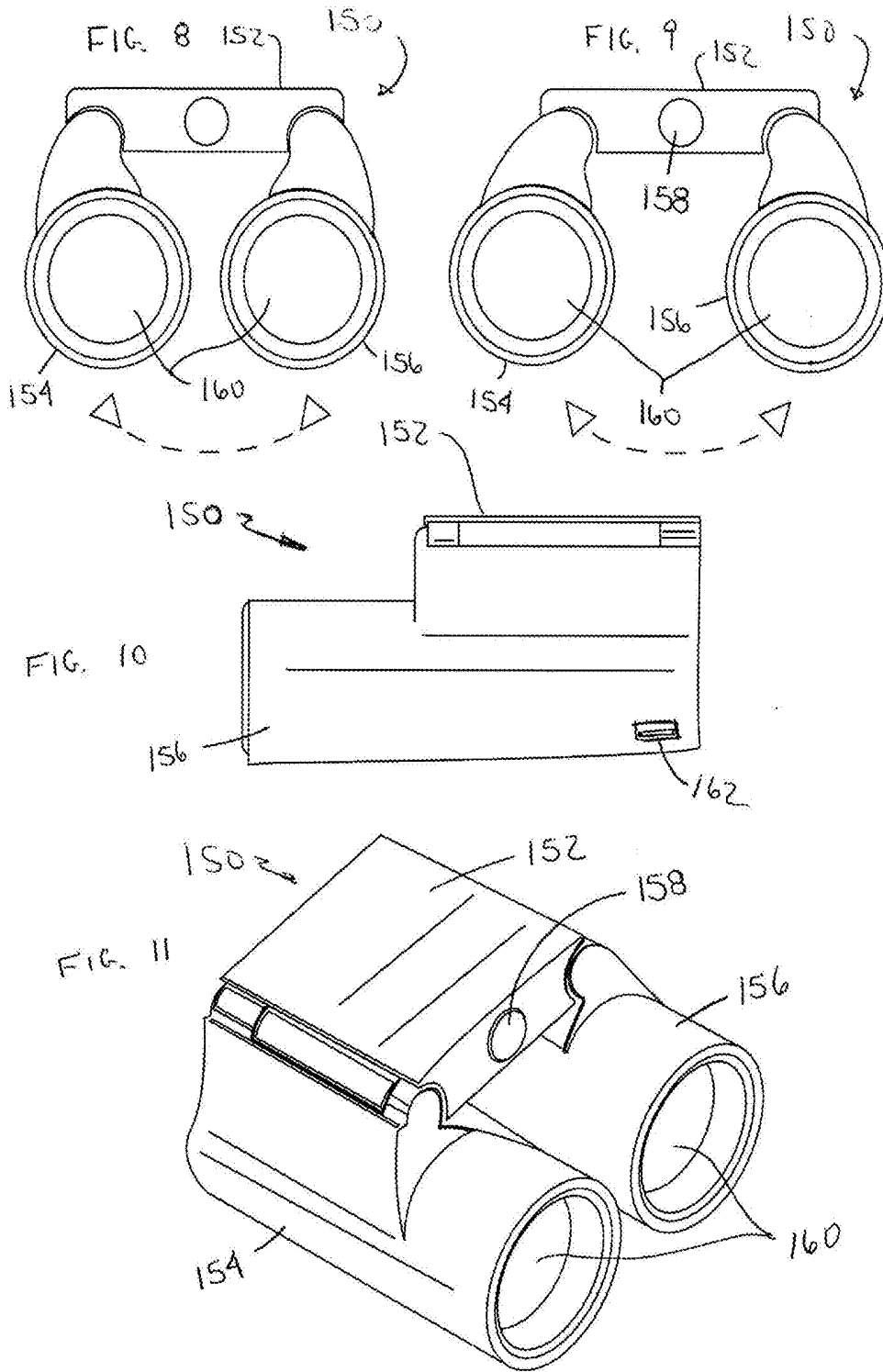


FIG. 8A

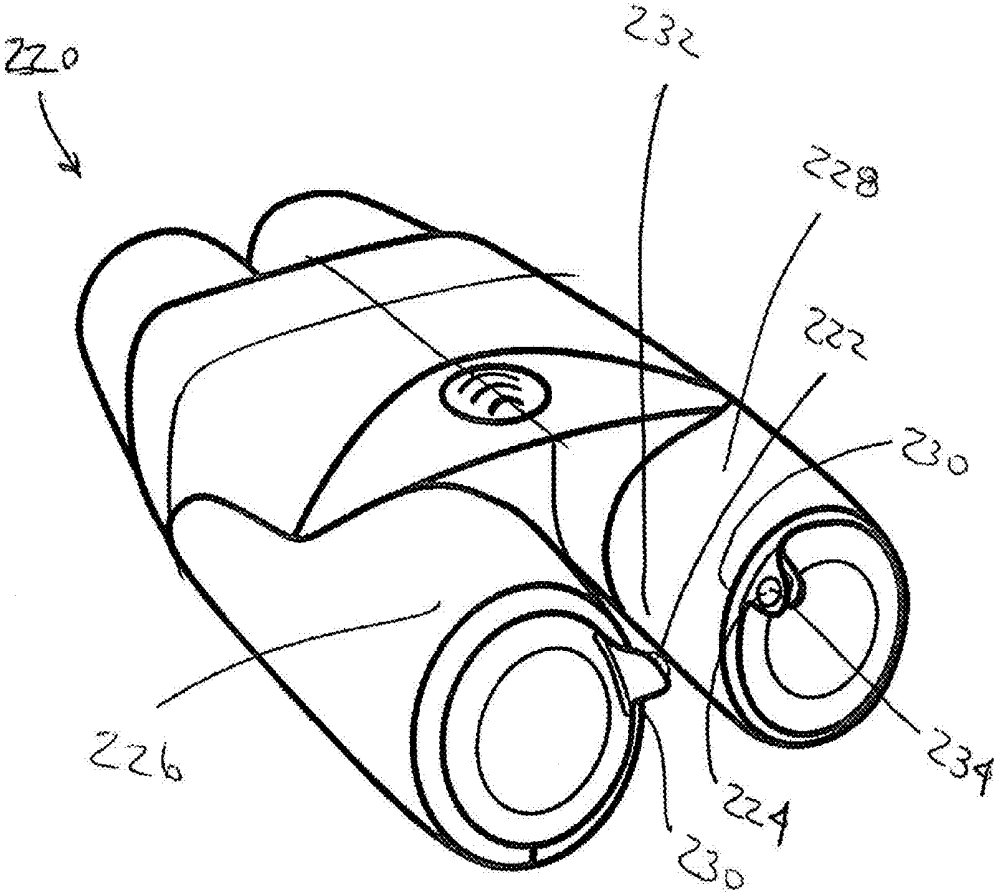
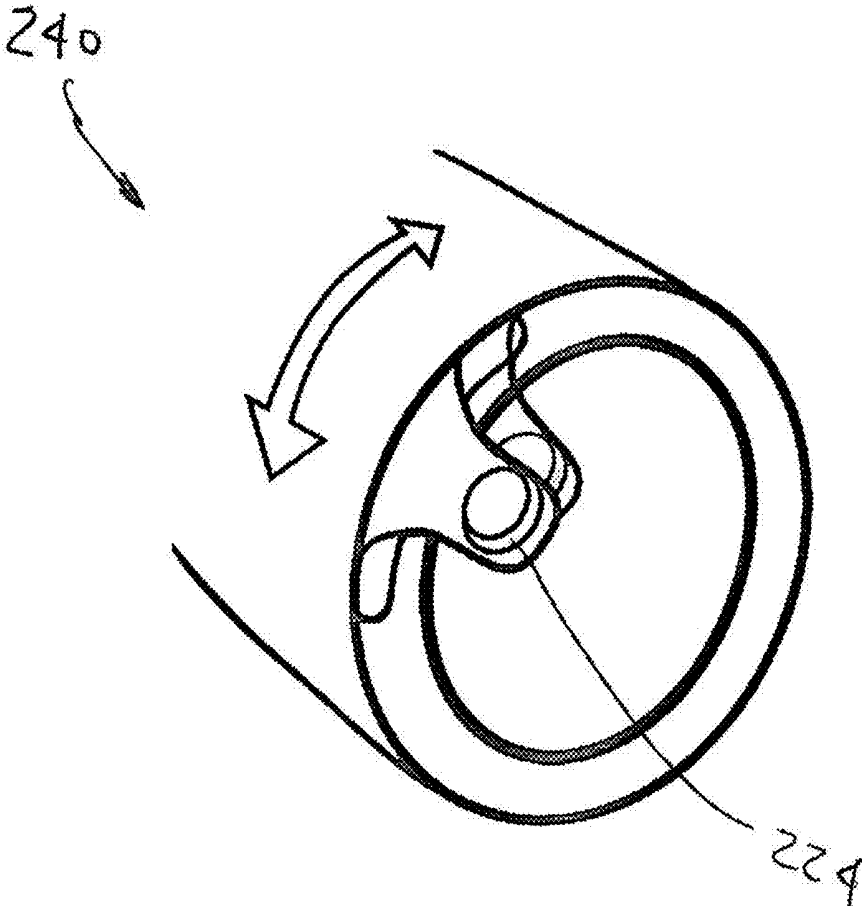
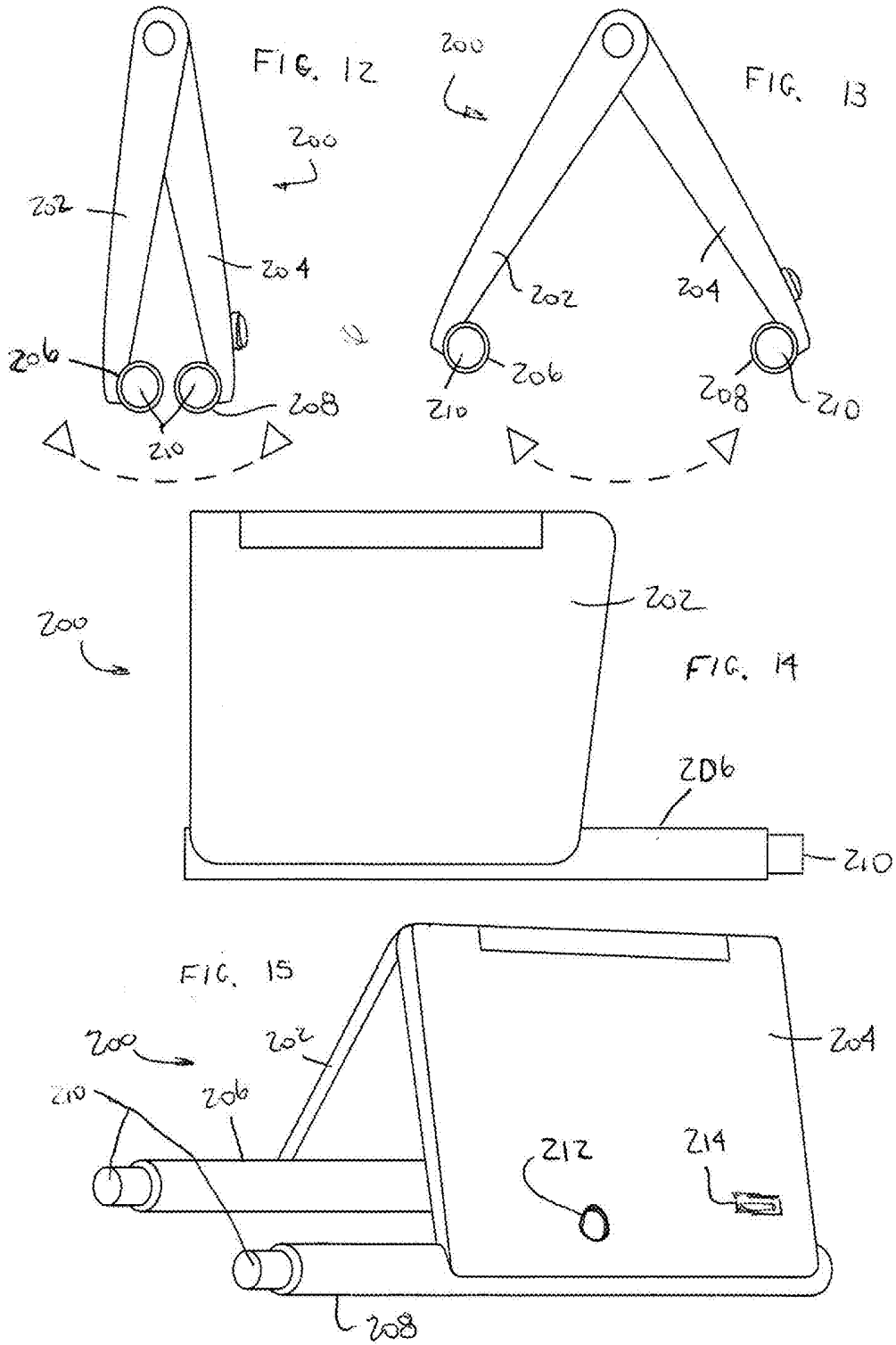


FIG. 8B





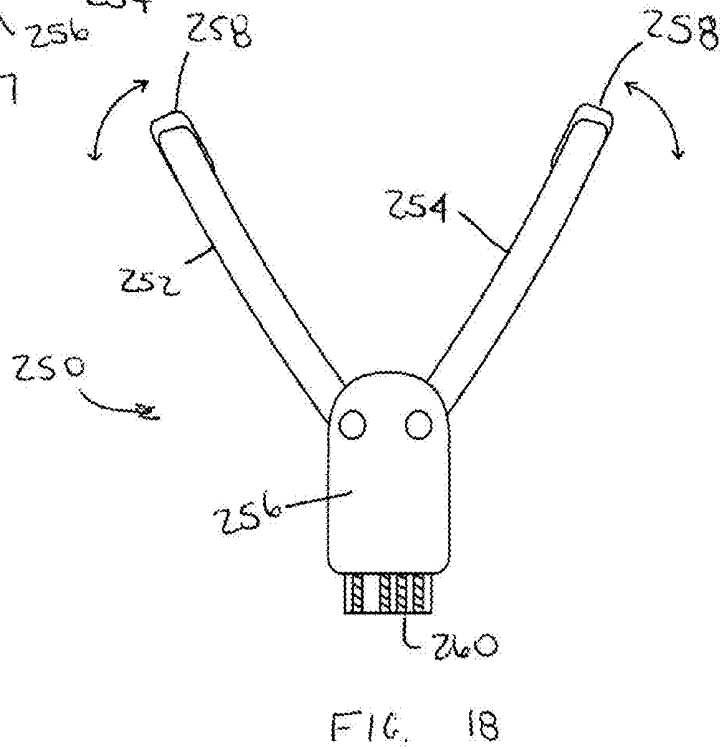
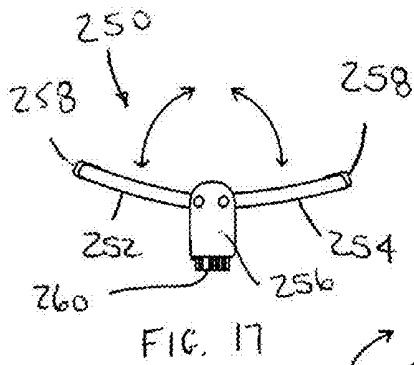
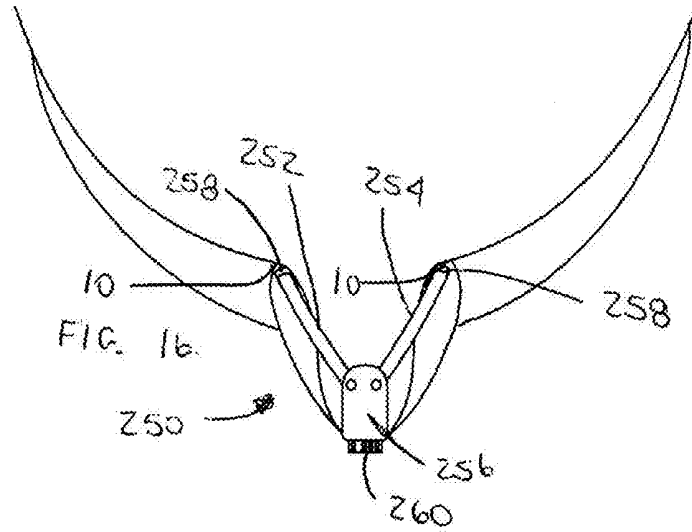


FIG. 19

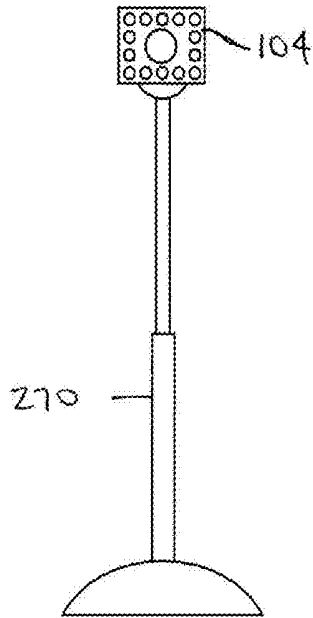


FIG. 20

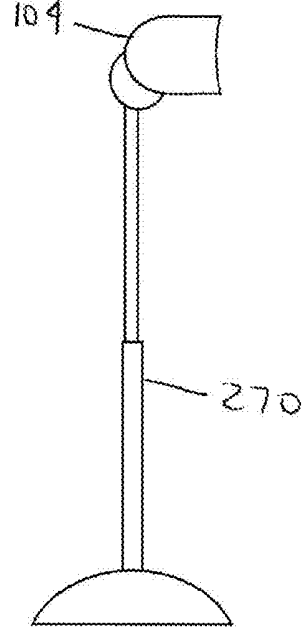


FIG. 21

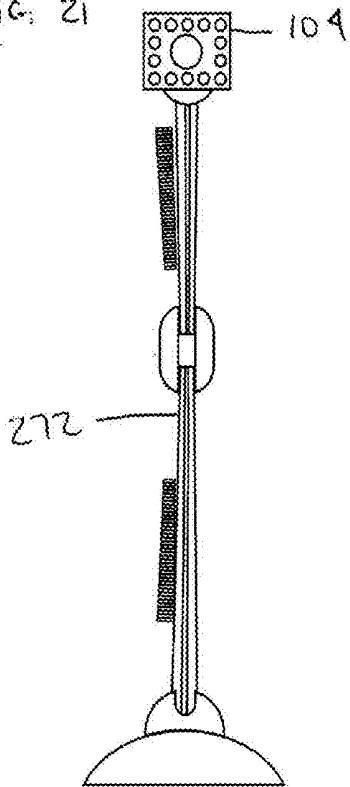


FIG. 22

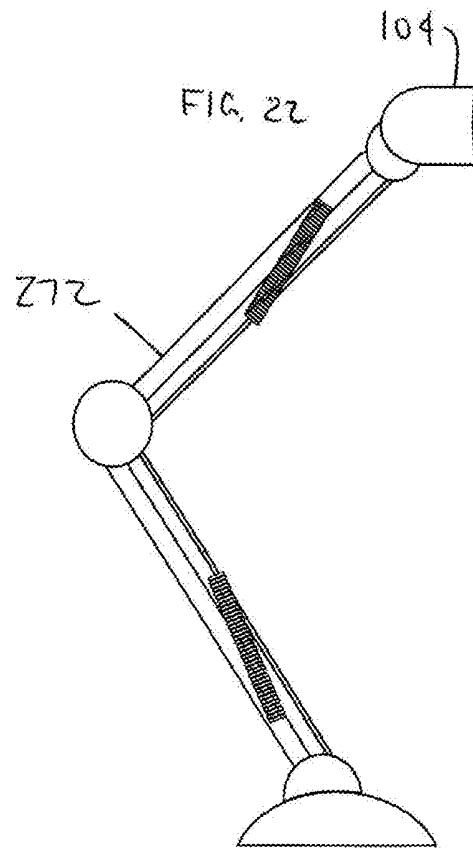


FIG. 23

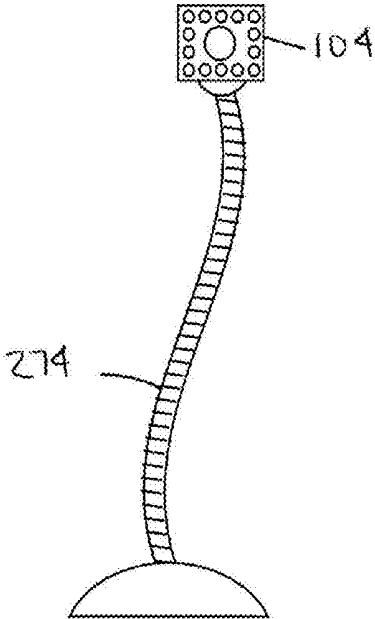


FIG. 24

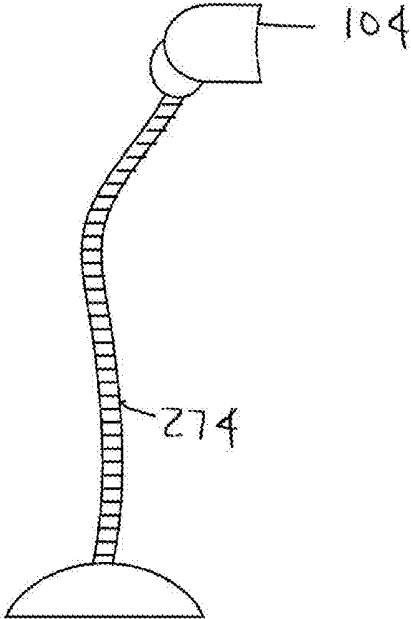


FIG. 25

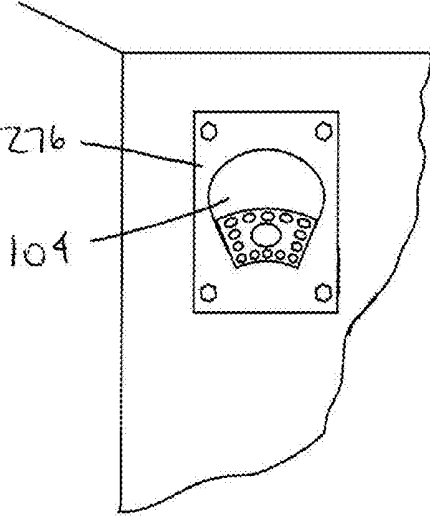


FIG. 26

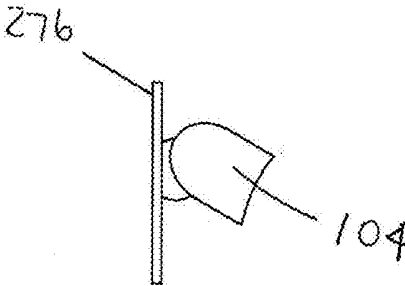


FIG. 27

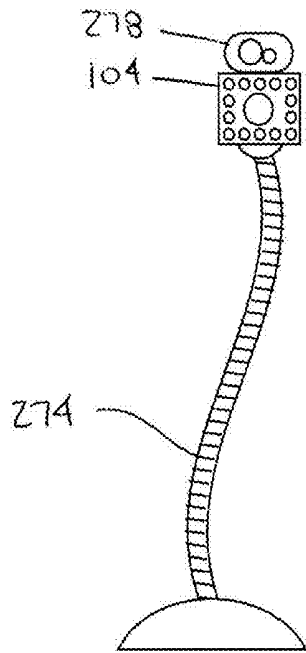


FIG. 28

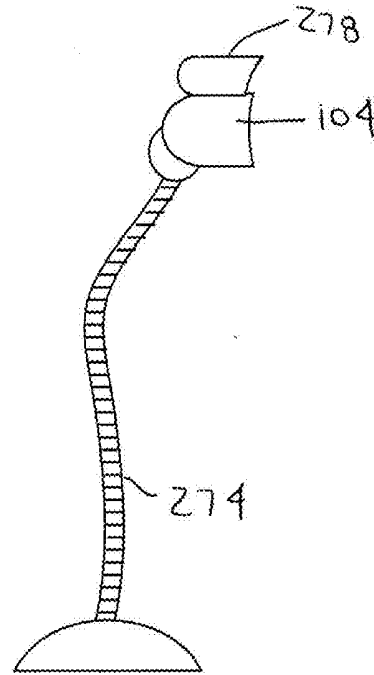


FIG. 29

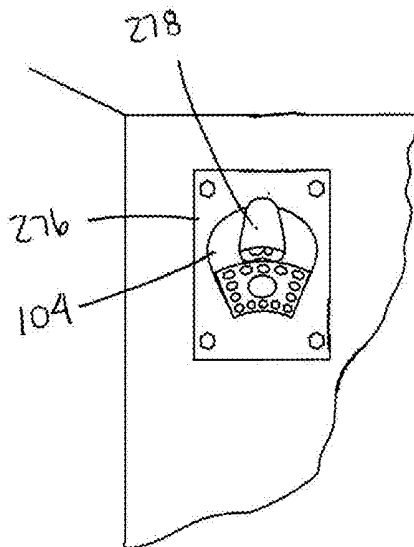


FIG. 30

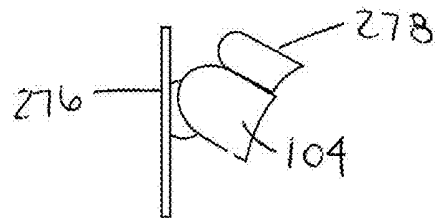


FIG. 30A

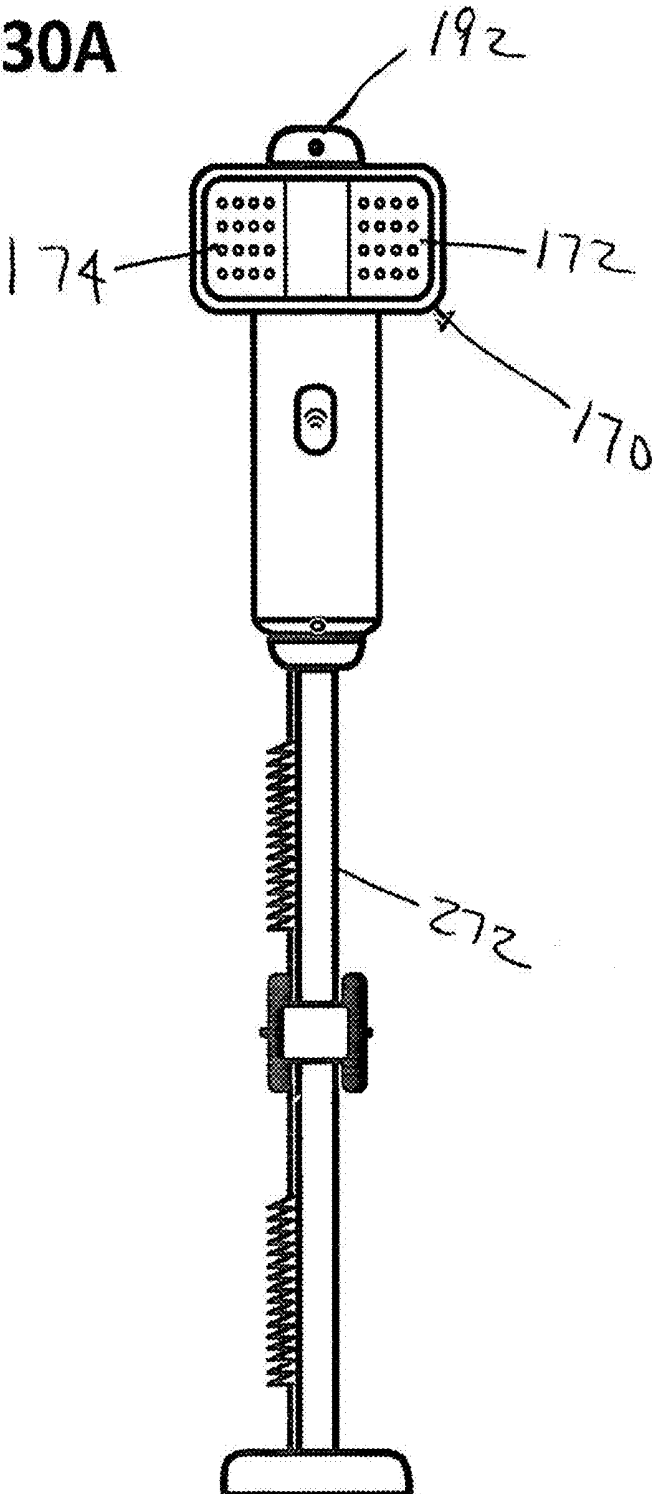


FIG. 30B

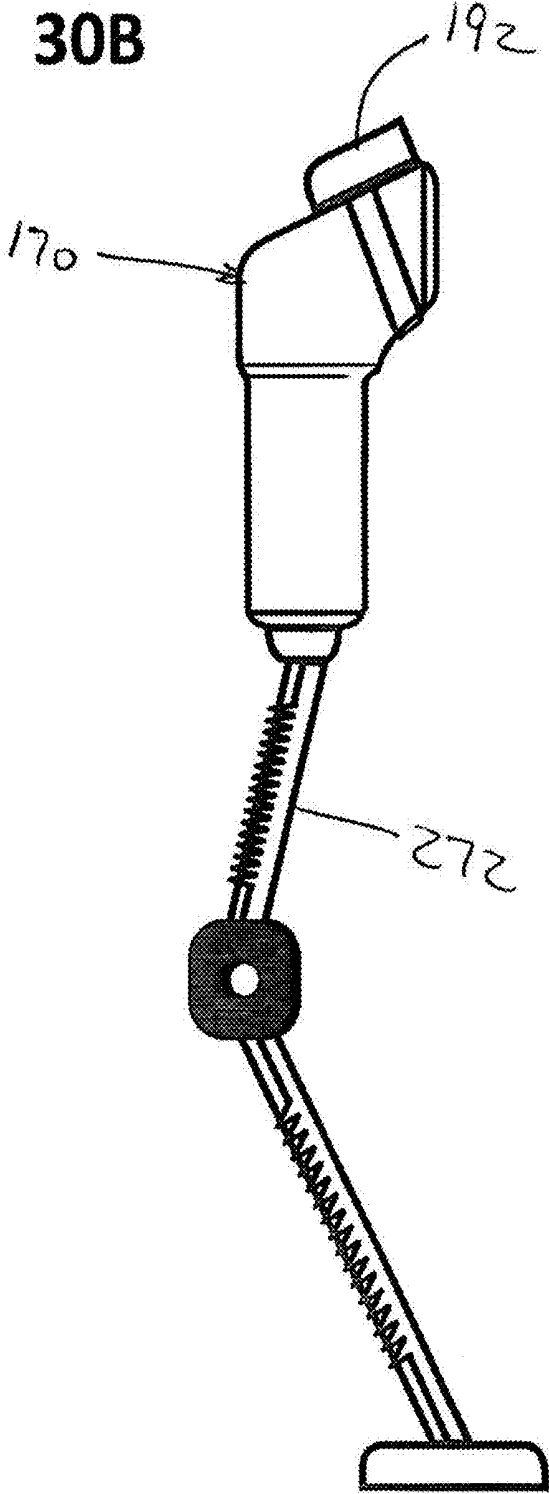
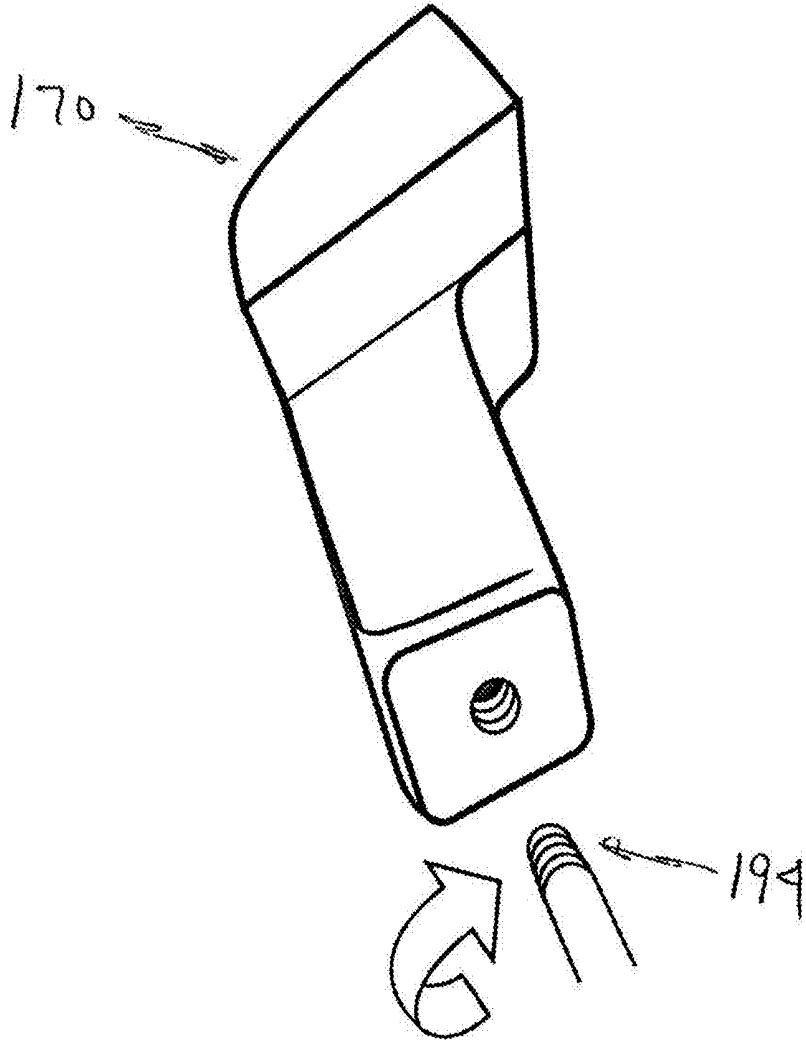


FIG. 30C



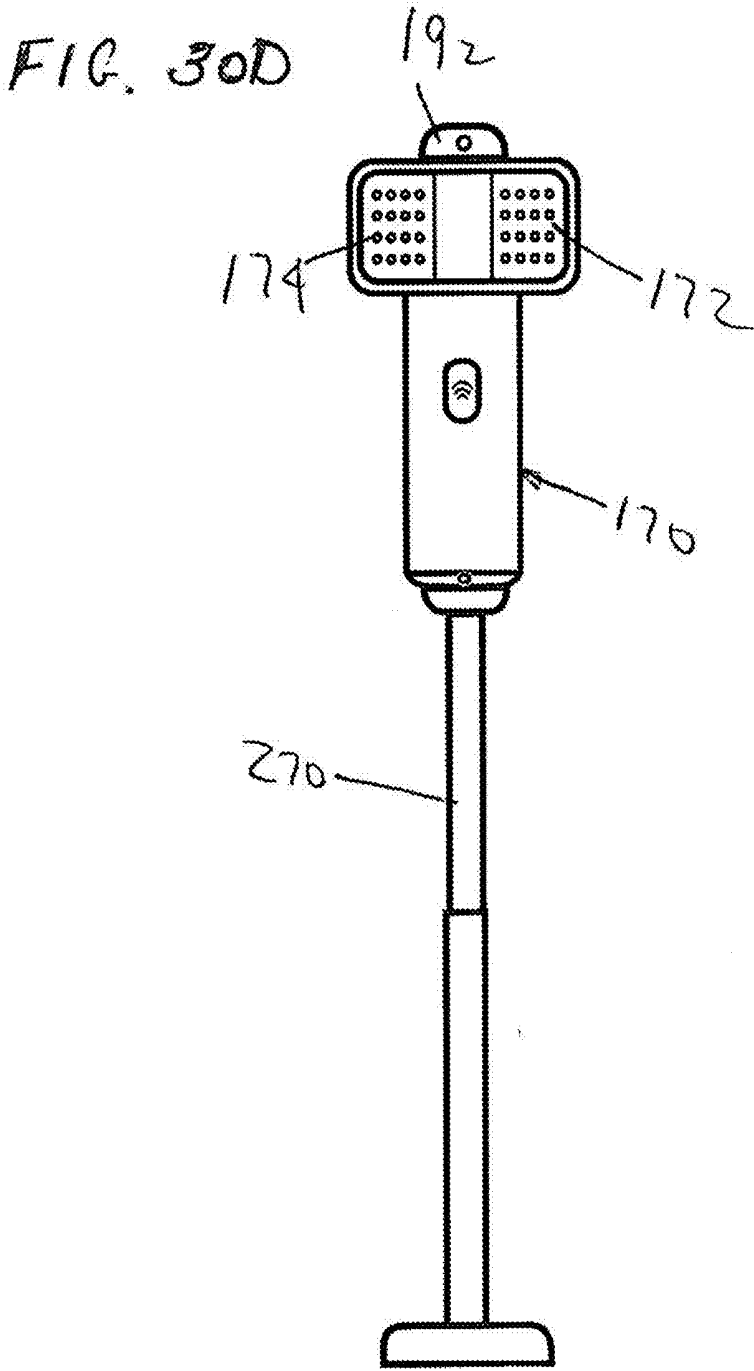
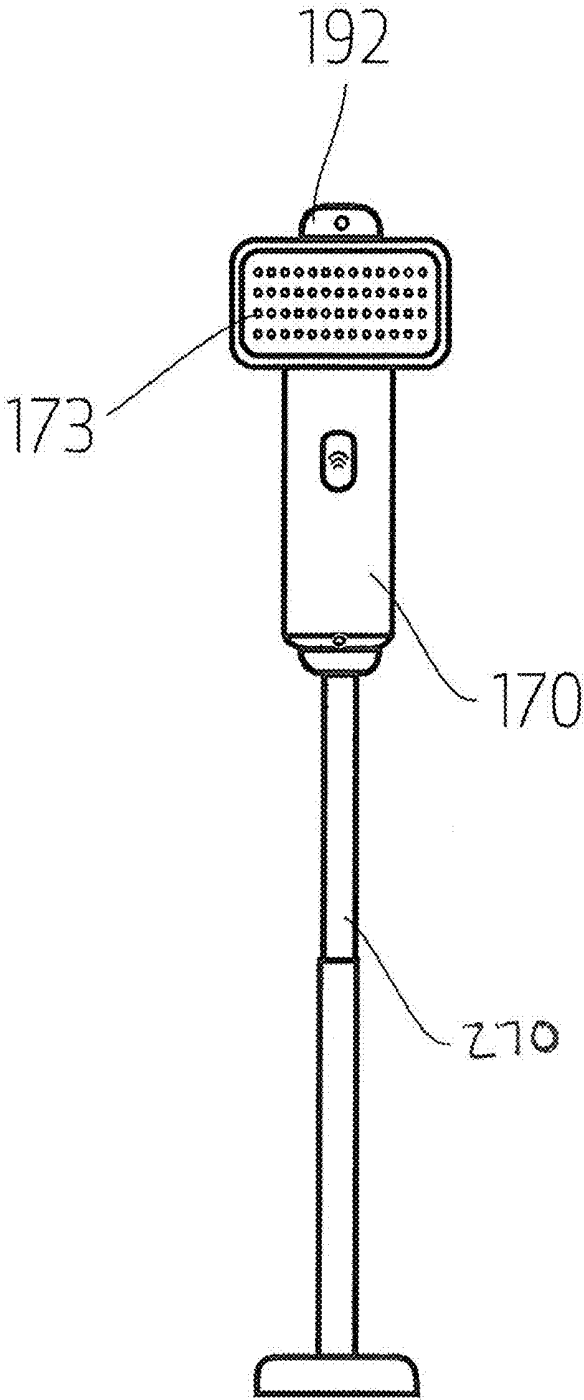
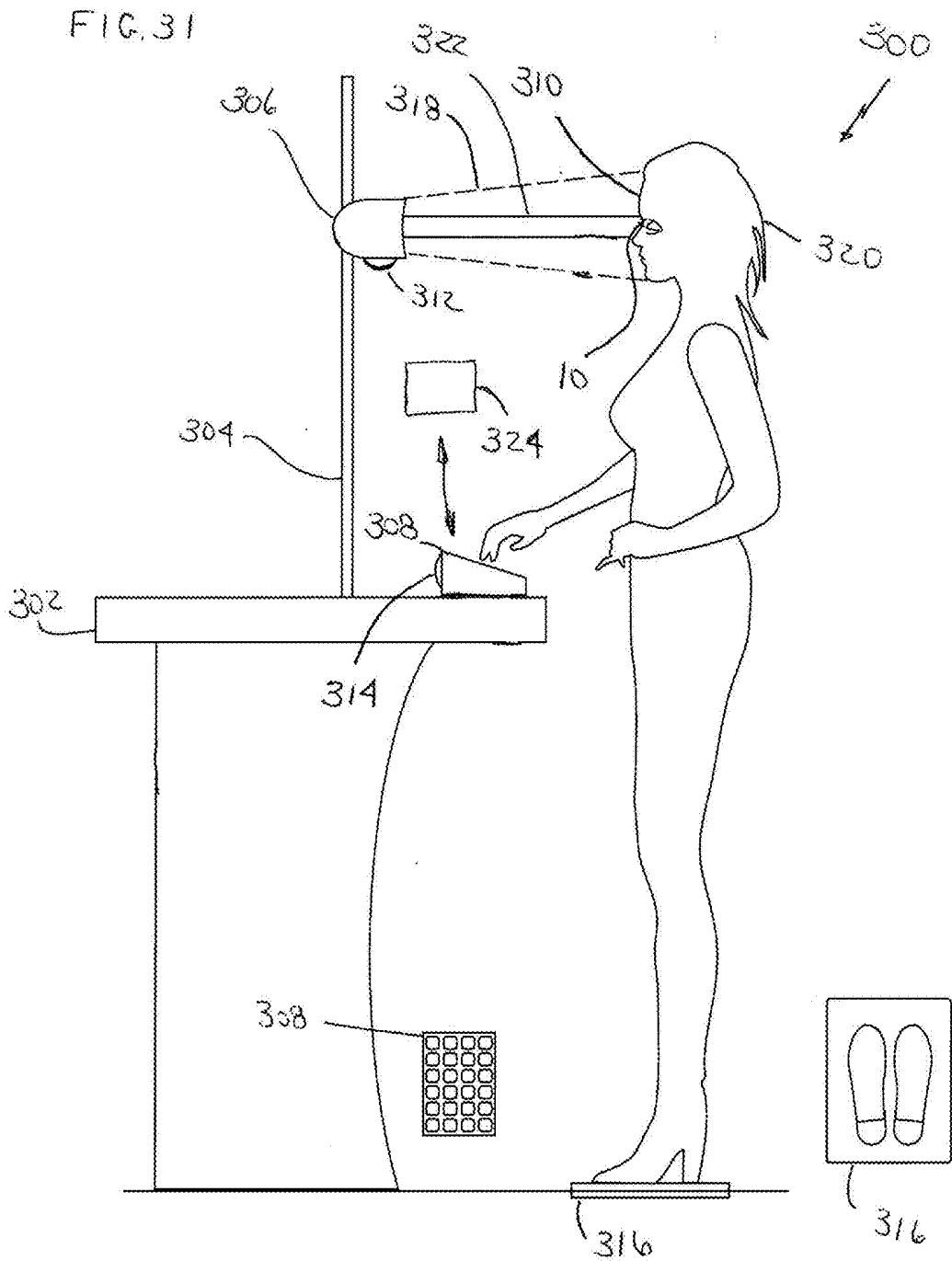


Fig. 30E





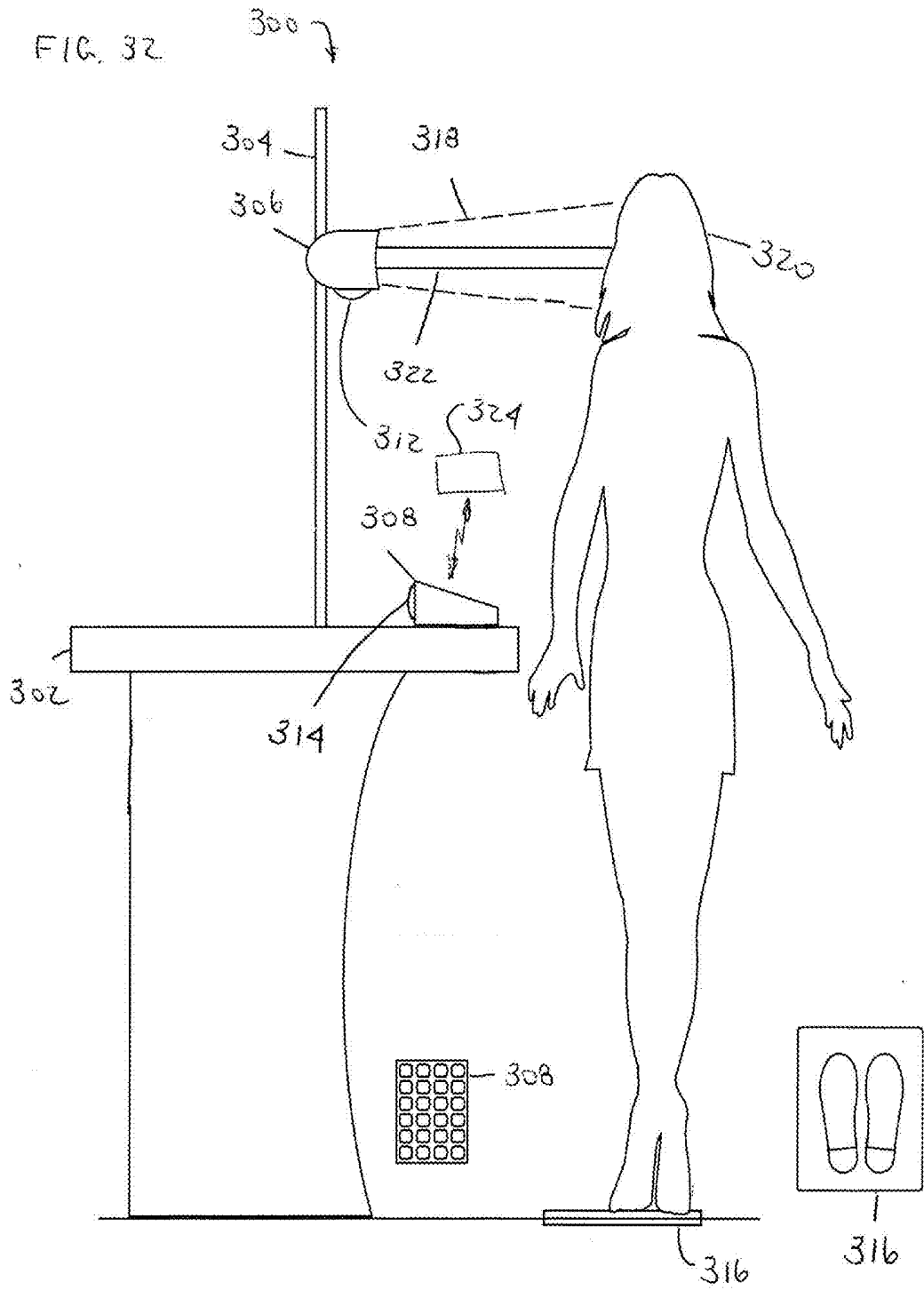
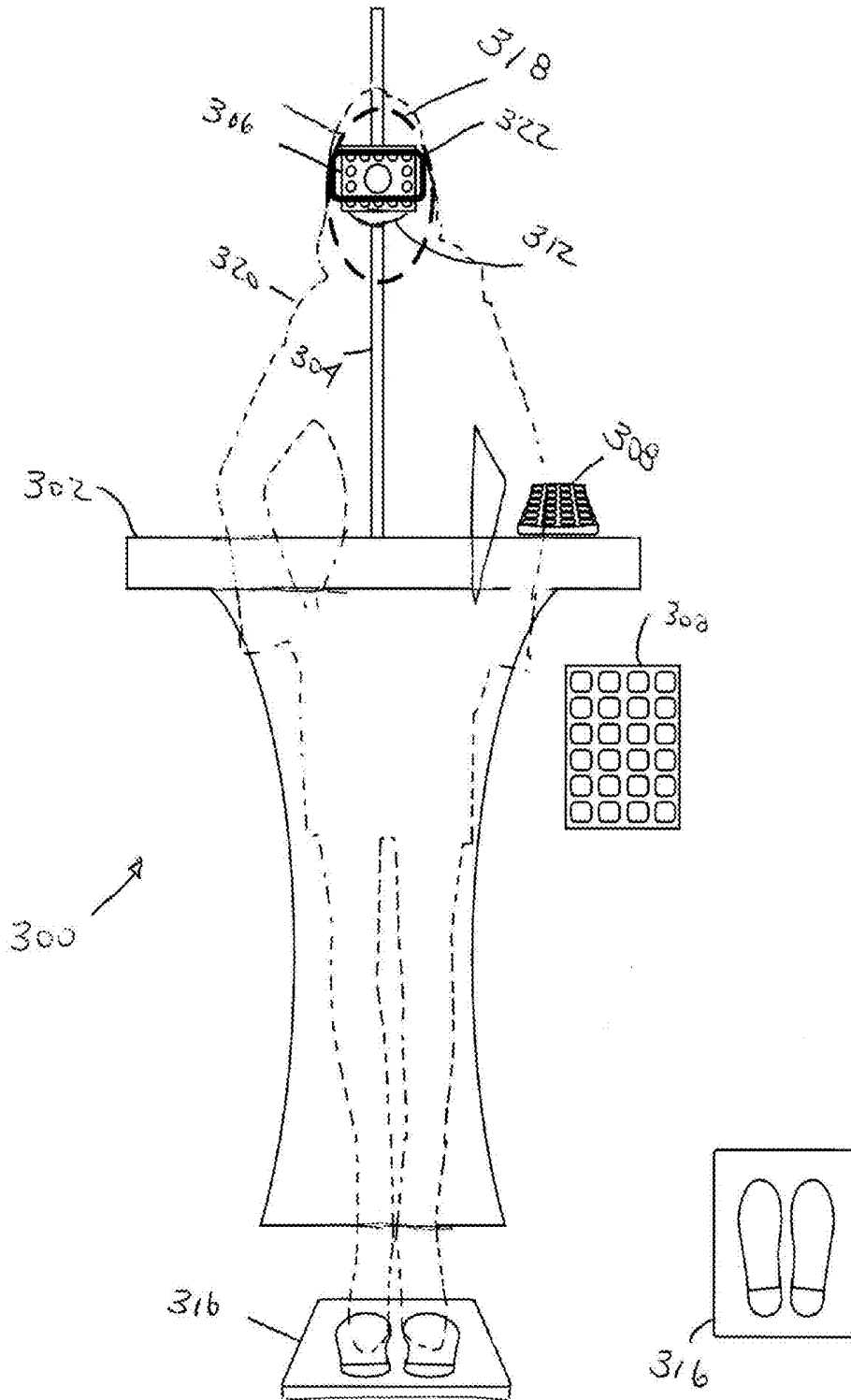


FIG. 33



**Fig. 33A**

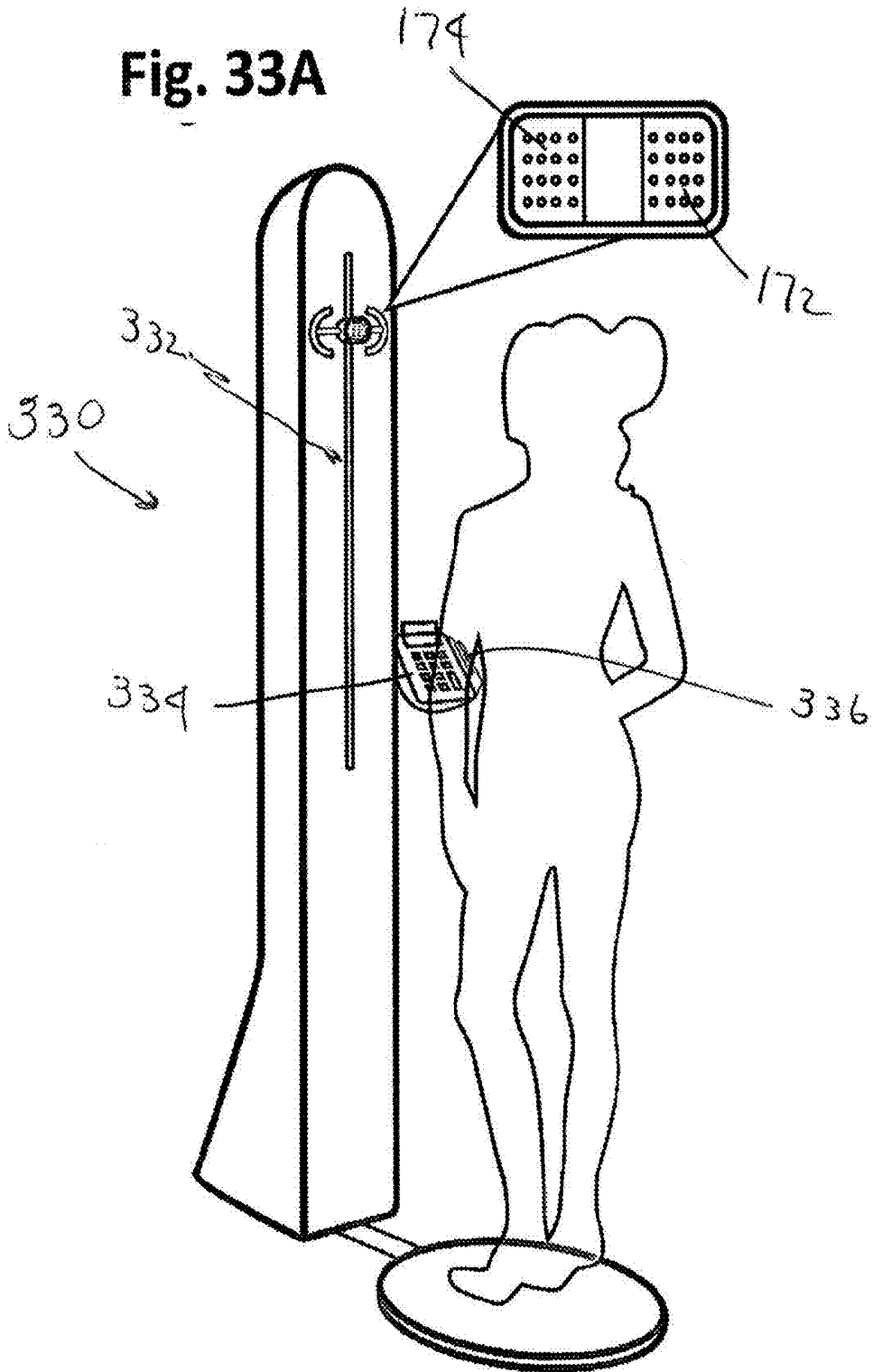
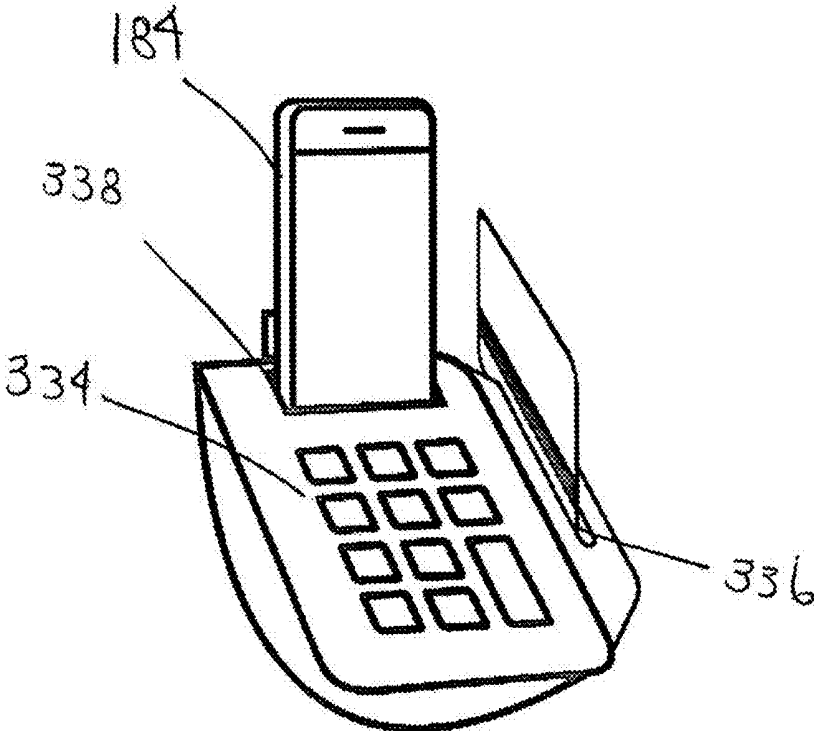
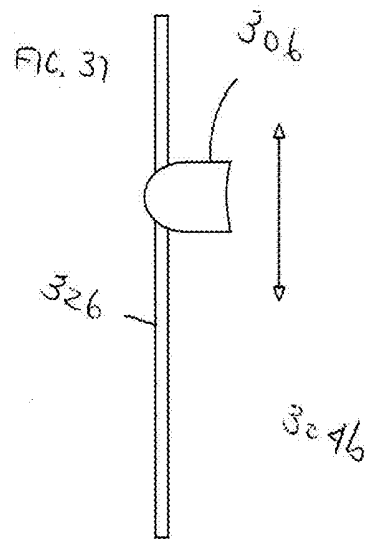
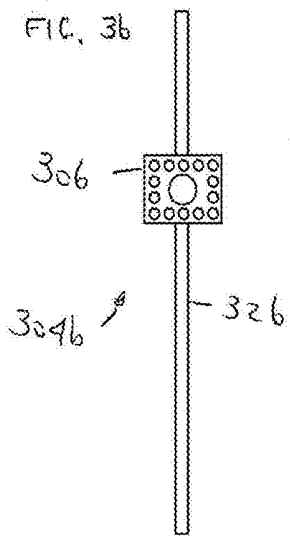
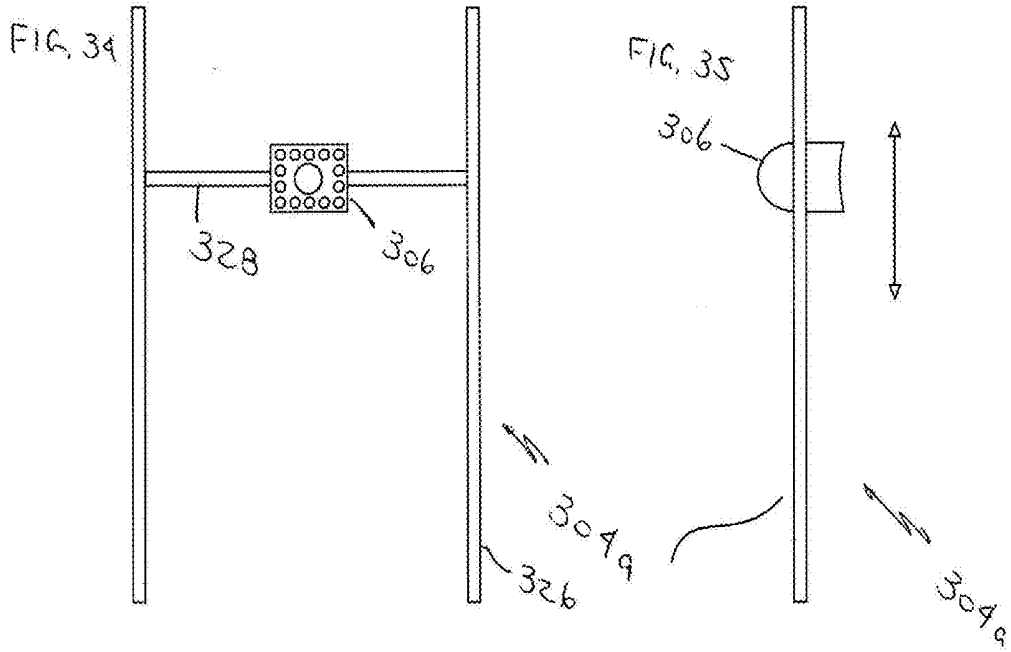


FIG. 33B





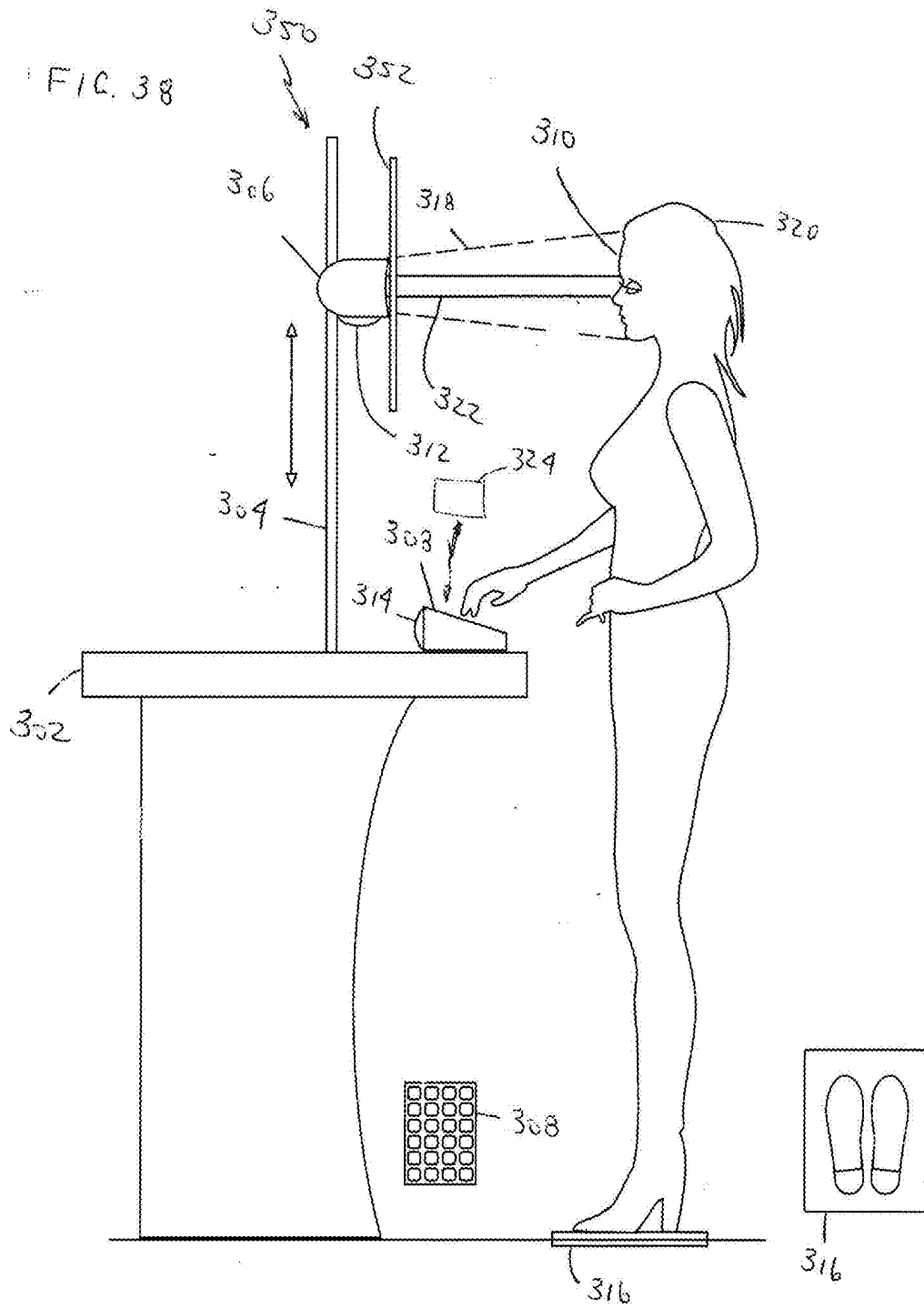
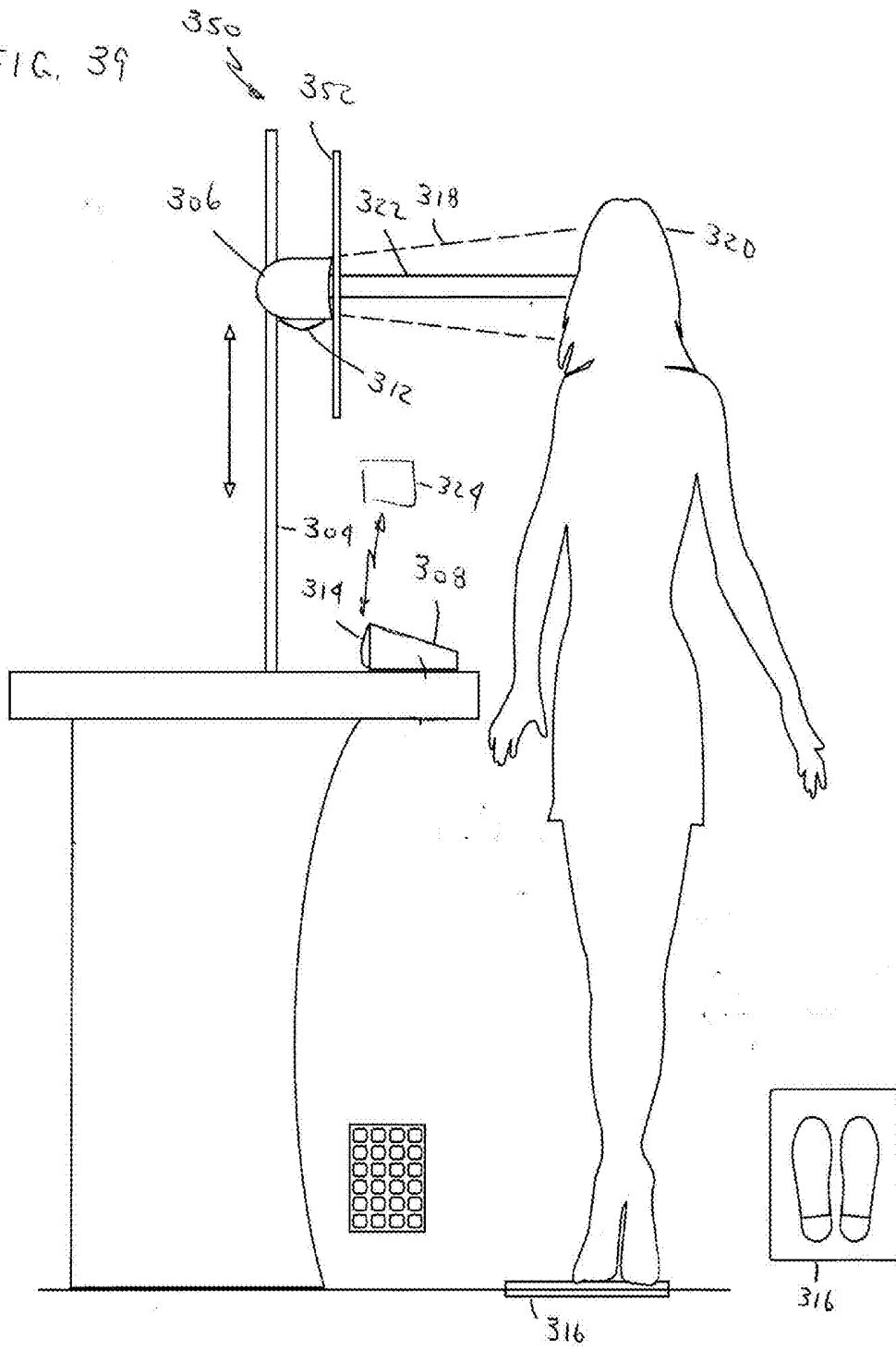
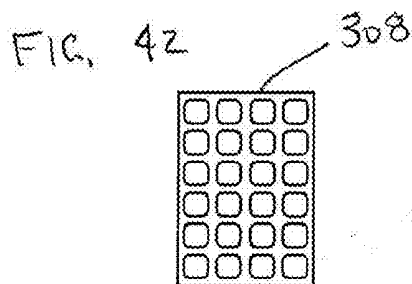
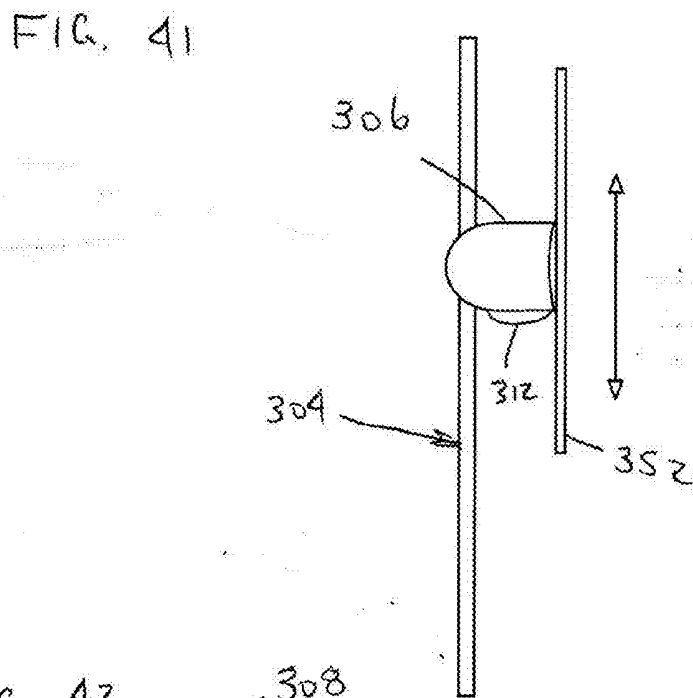
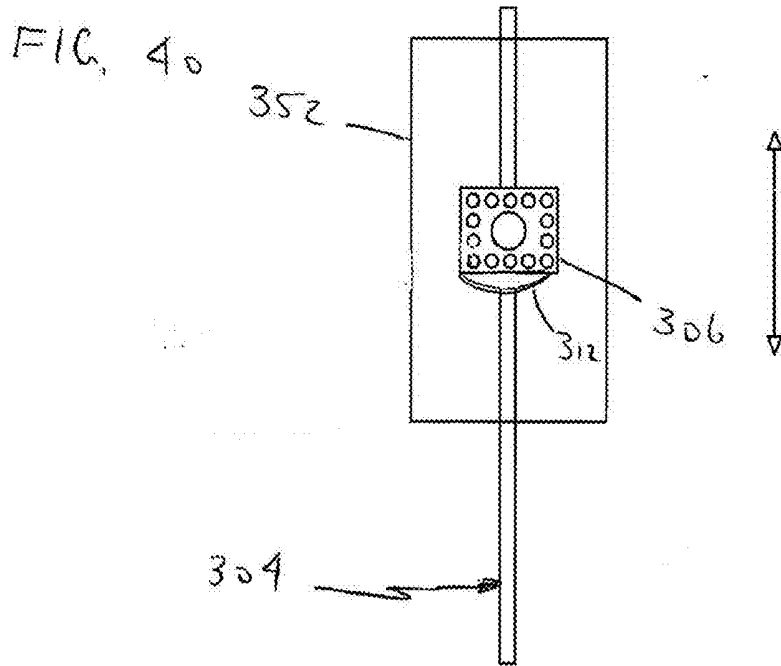
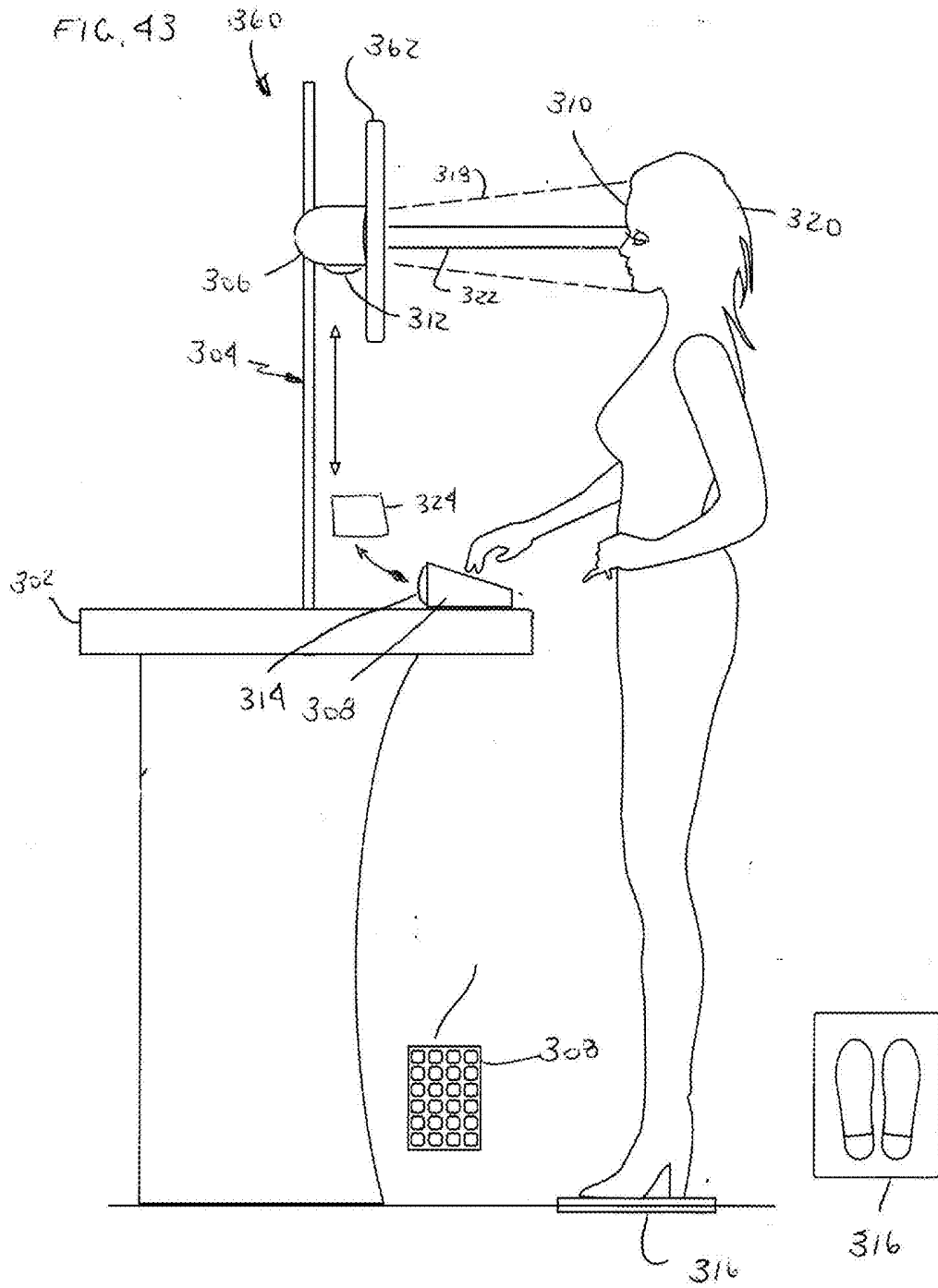


FIG. 39







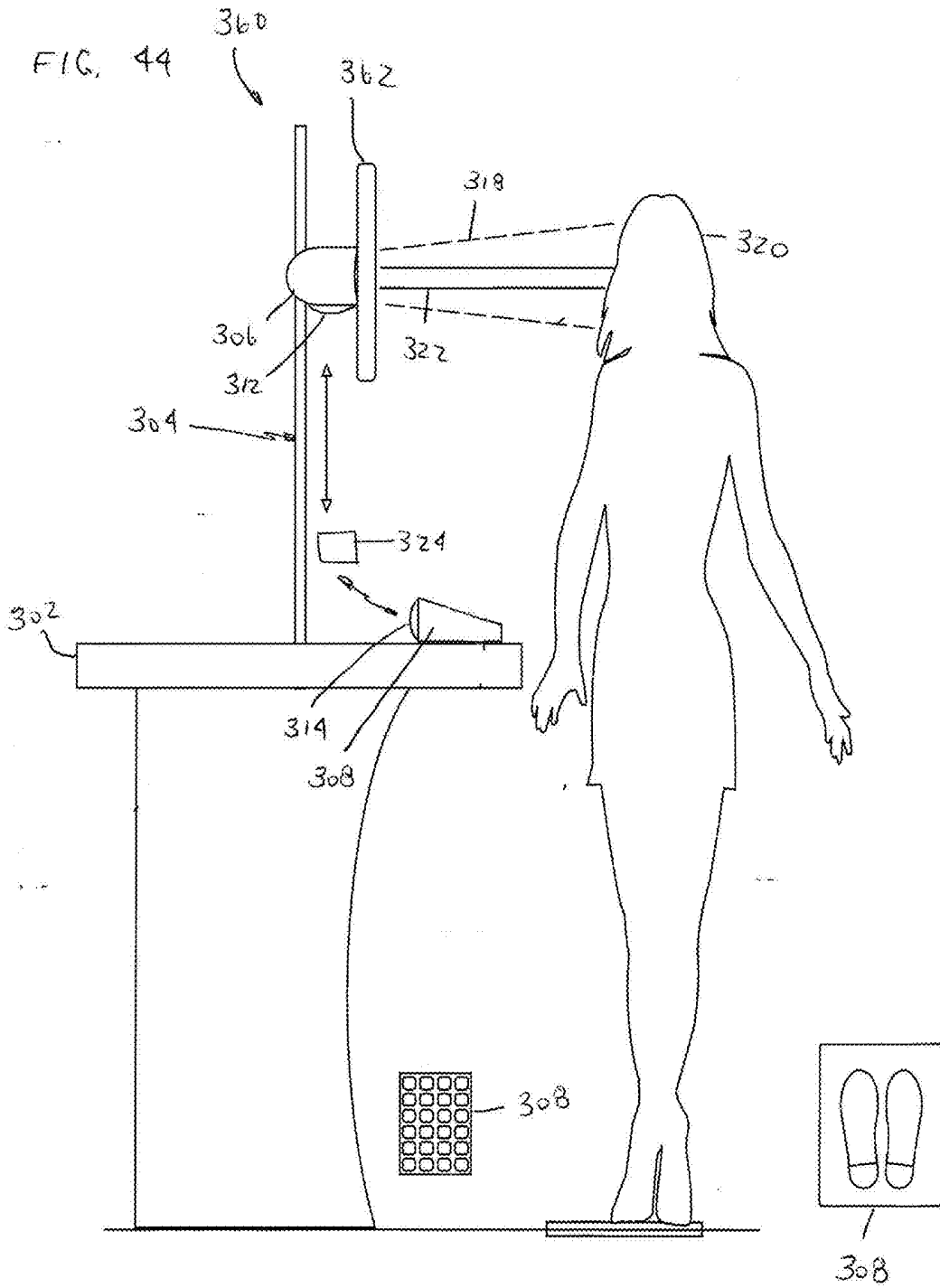


FIG. 45

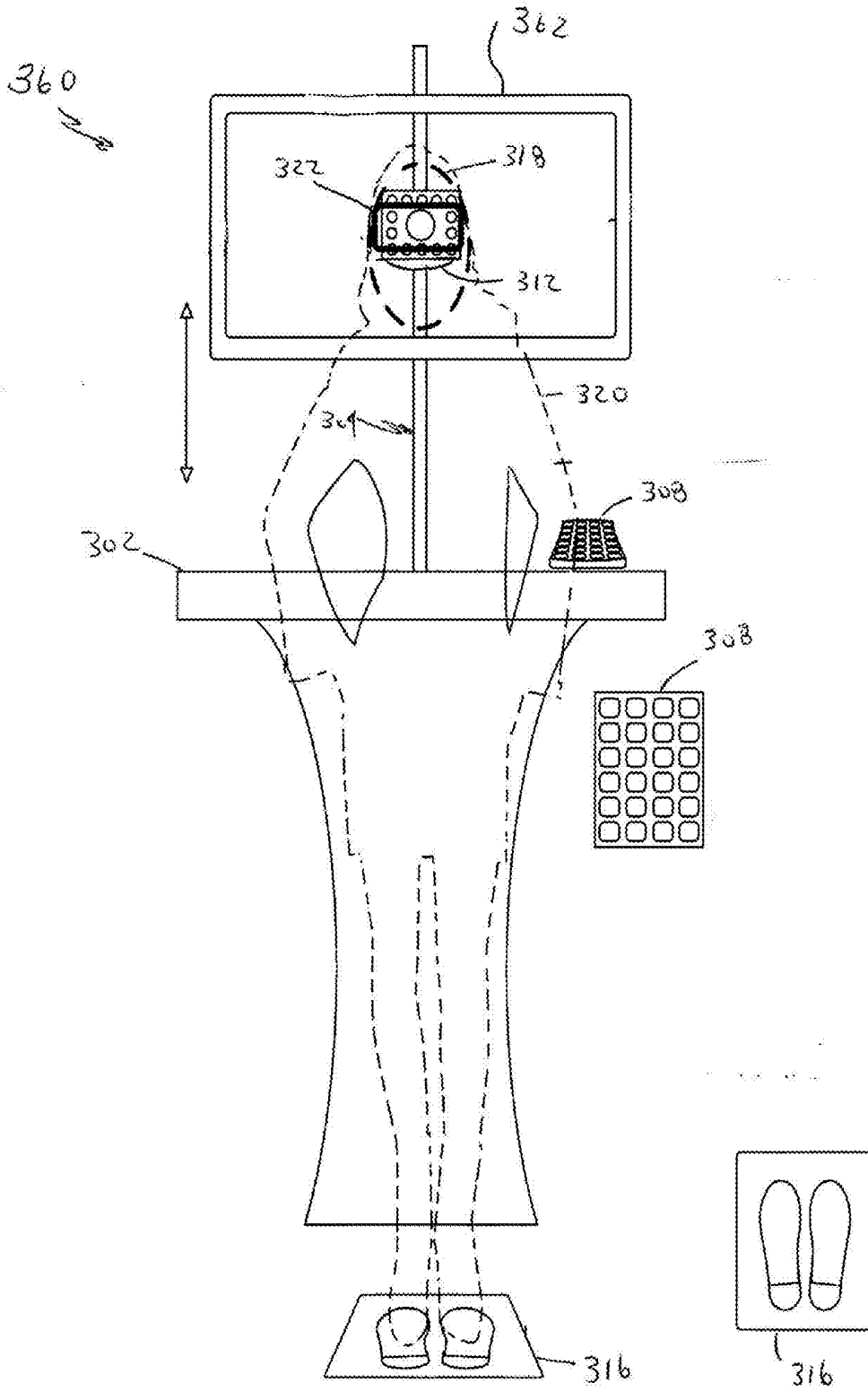


FIG. 46

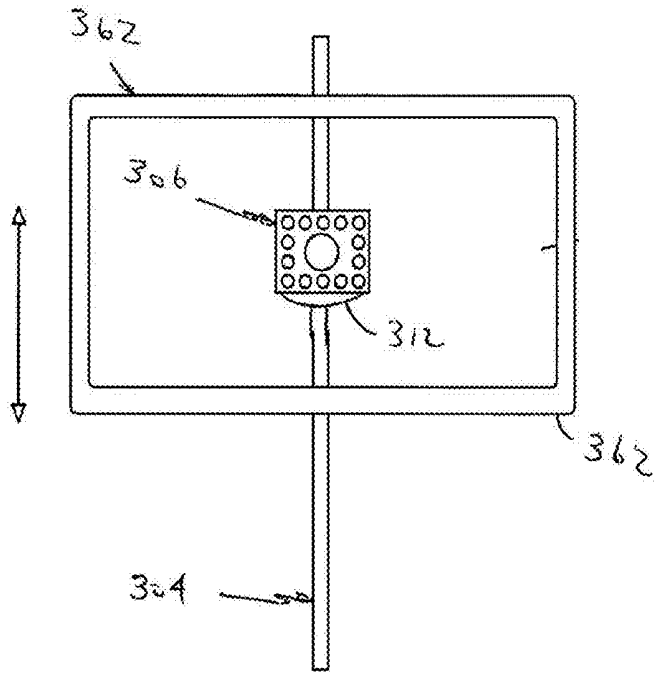


FIG. 47

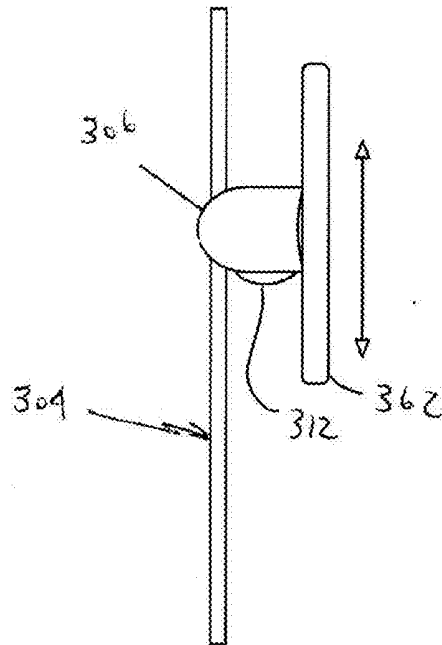
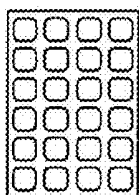
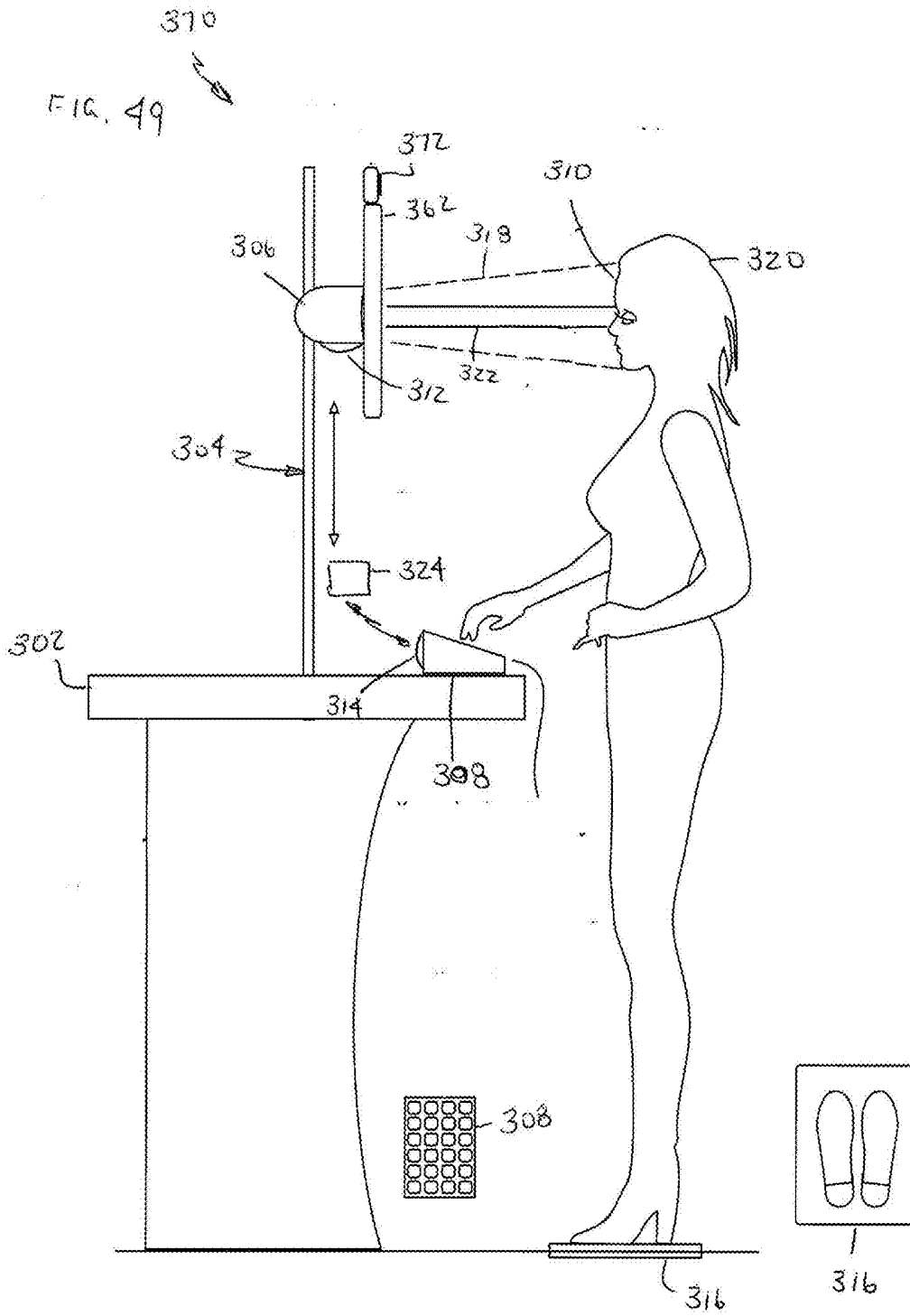
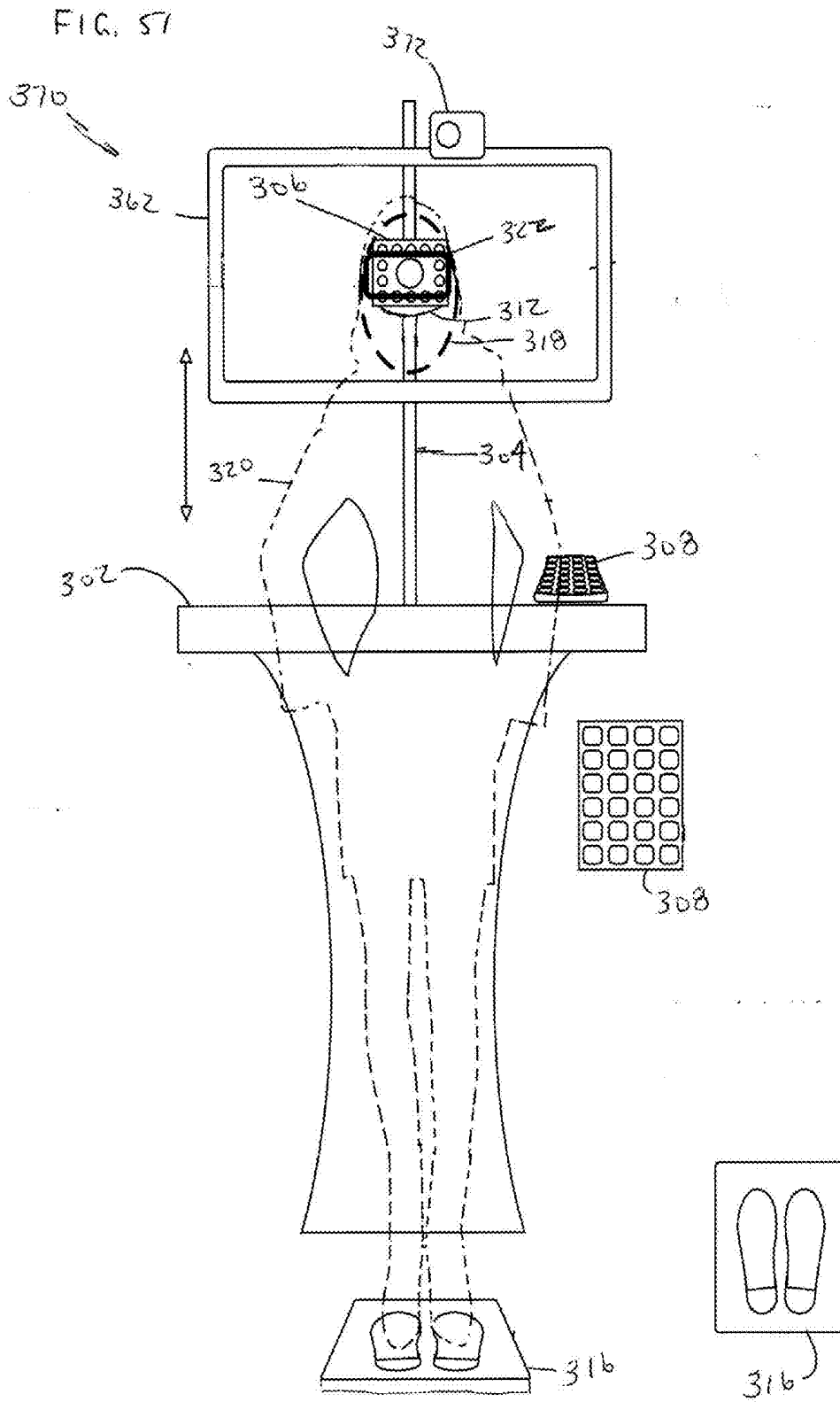


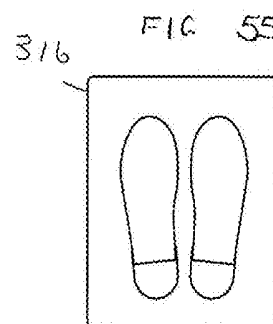
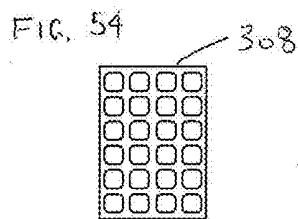
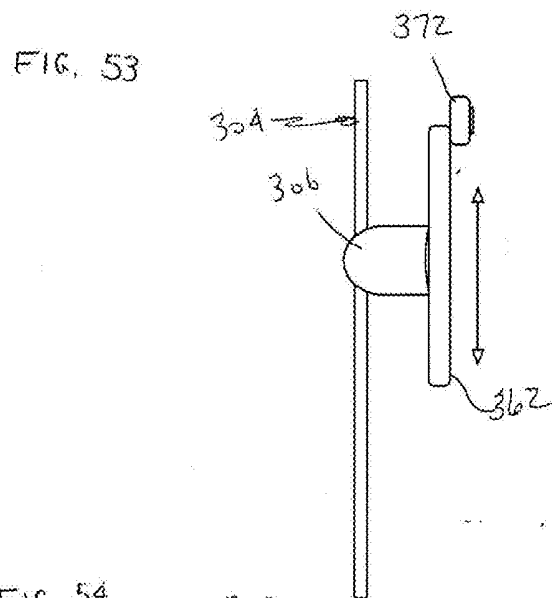
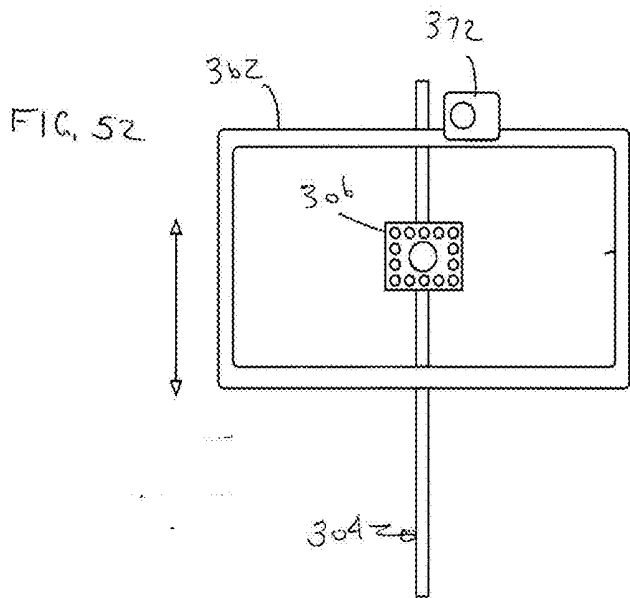
FIG. 48

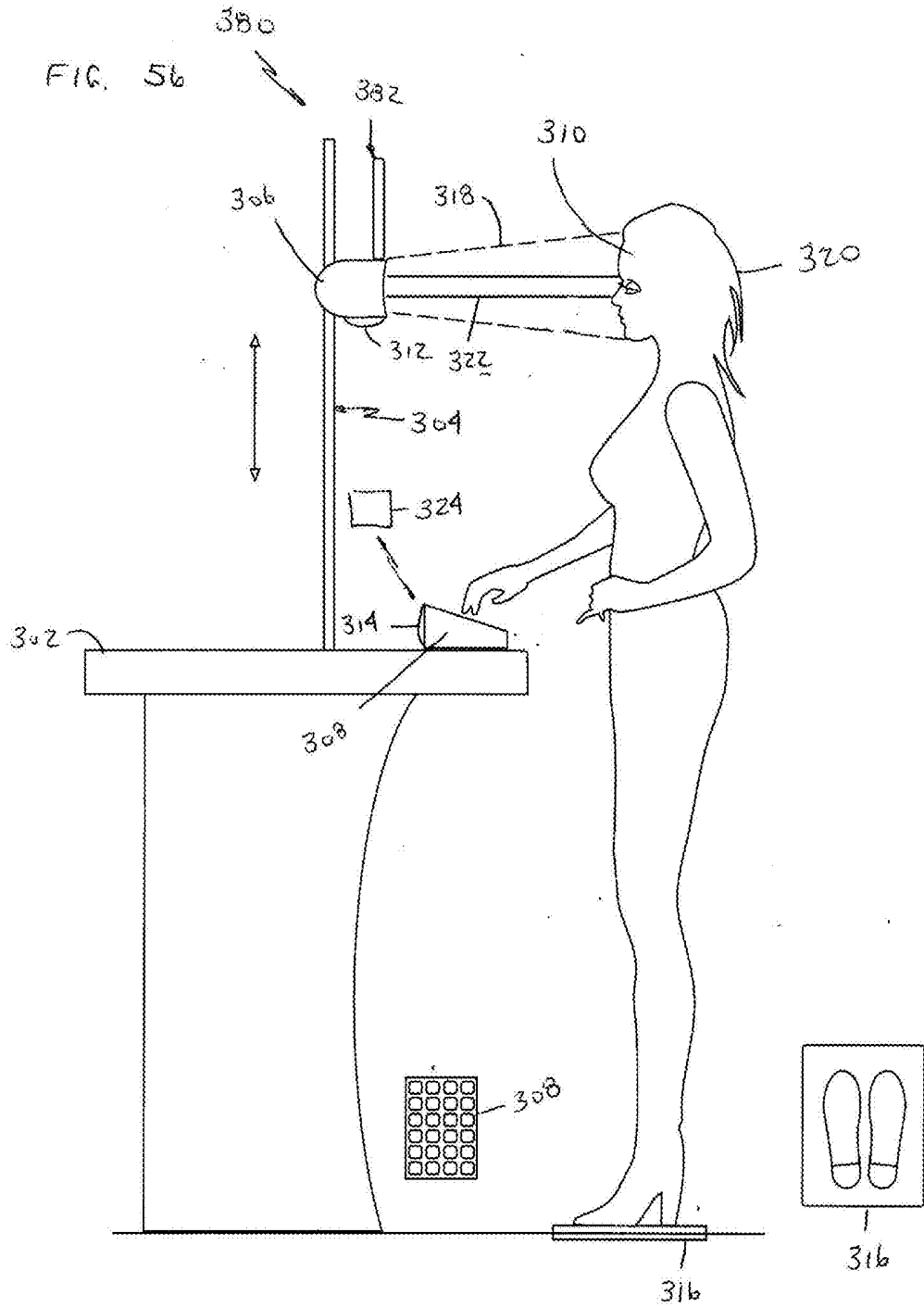












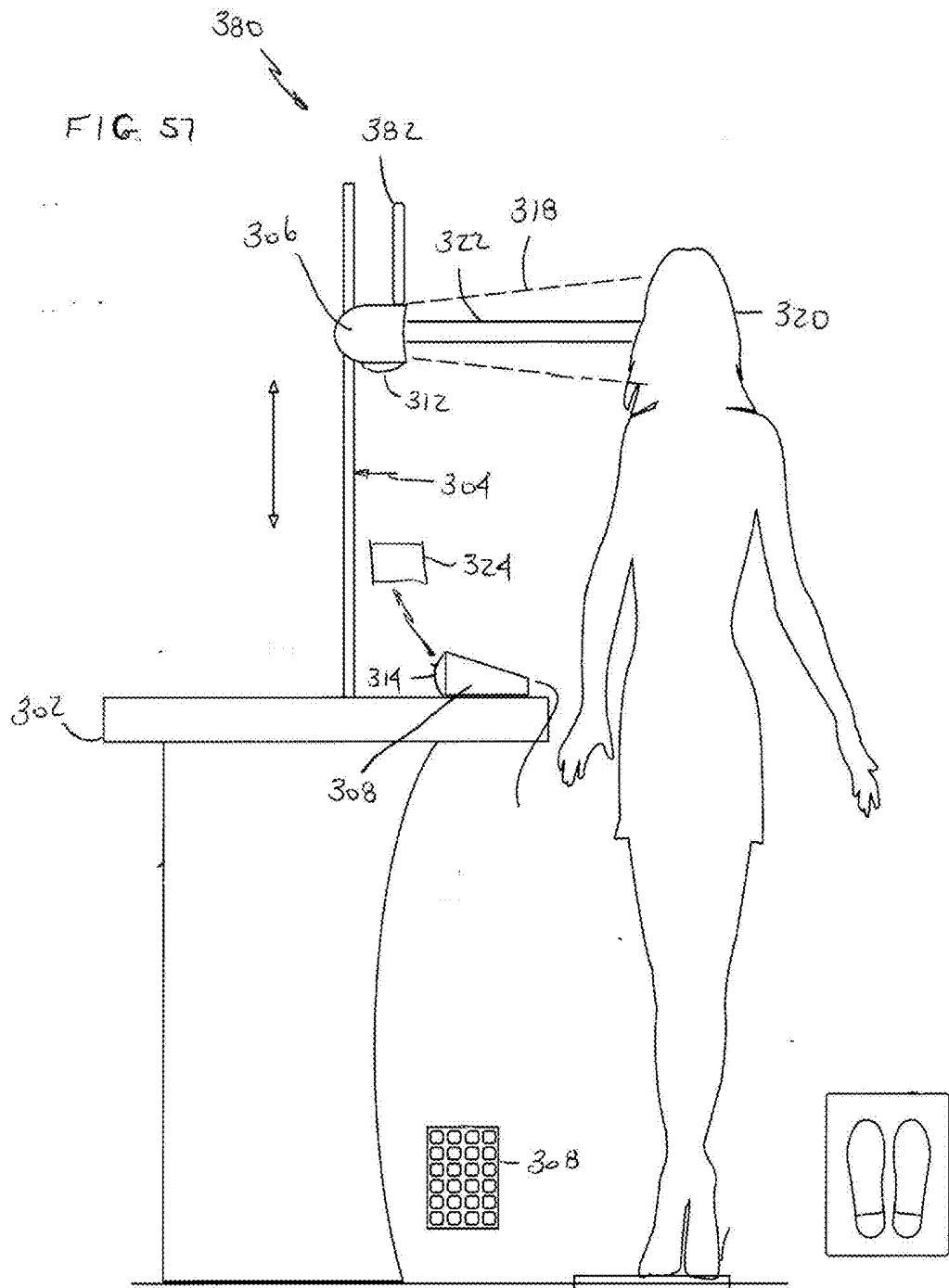
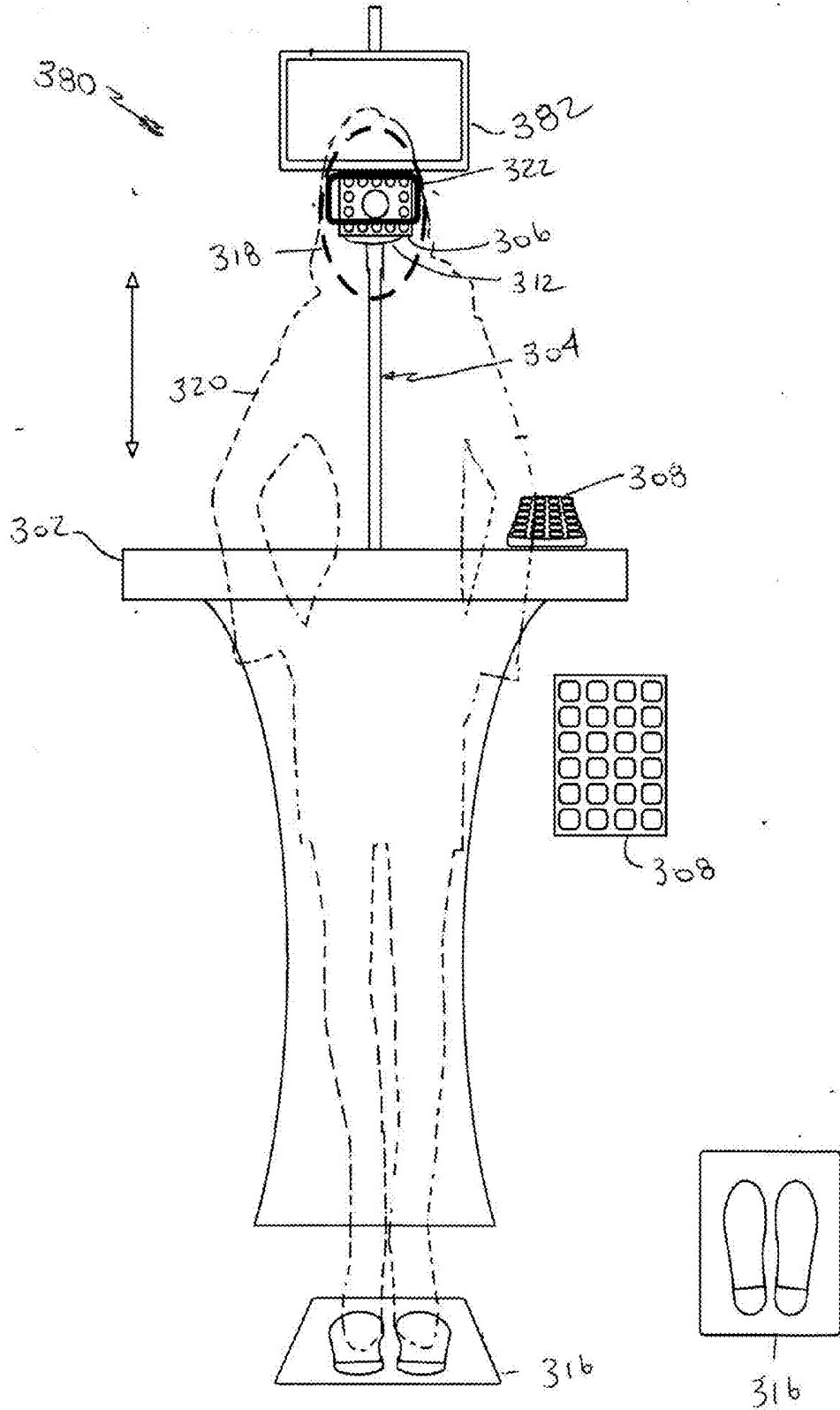


FIG. 58



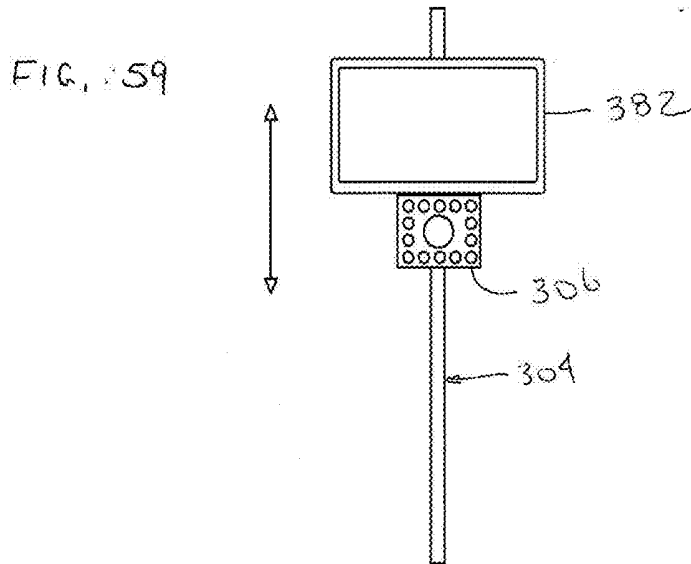


FIG. 60

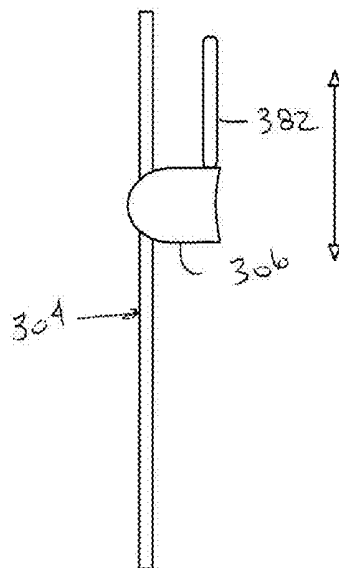


FIG. 61

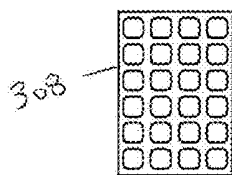
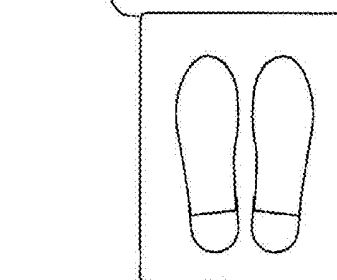


FIG. 62





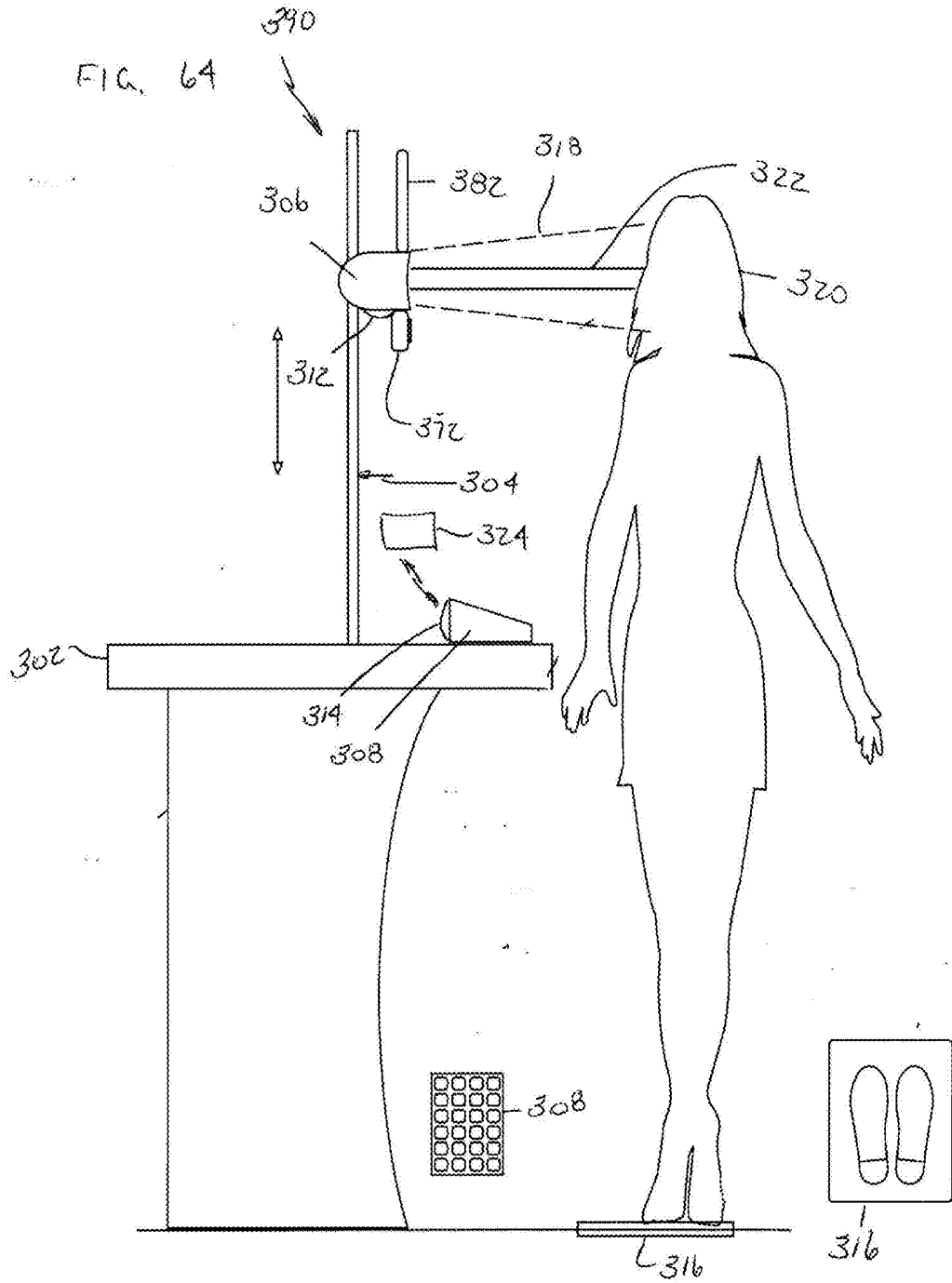
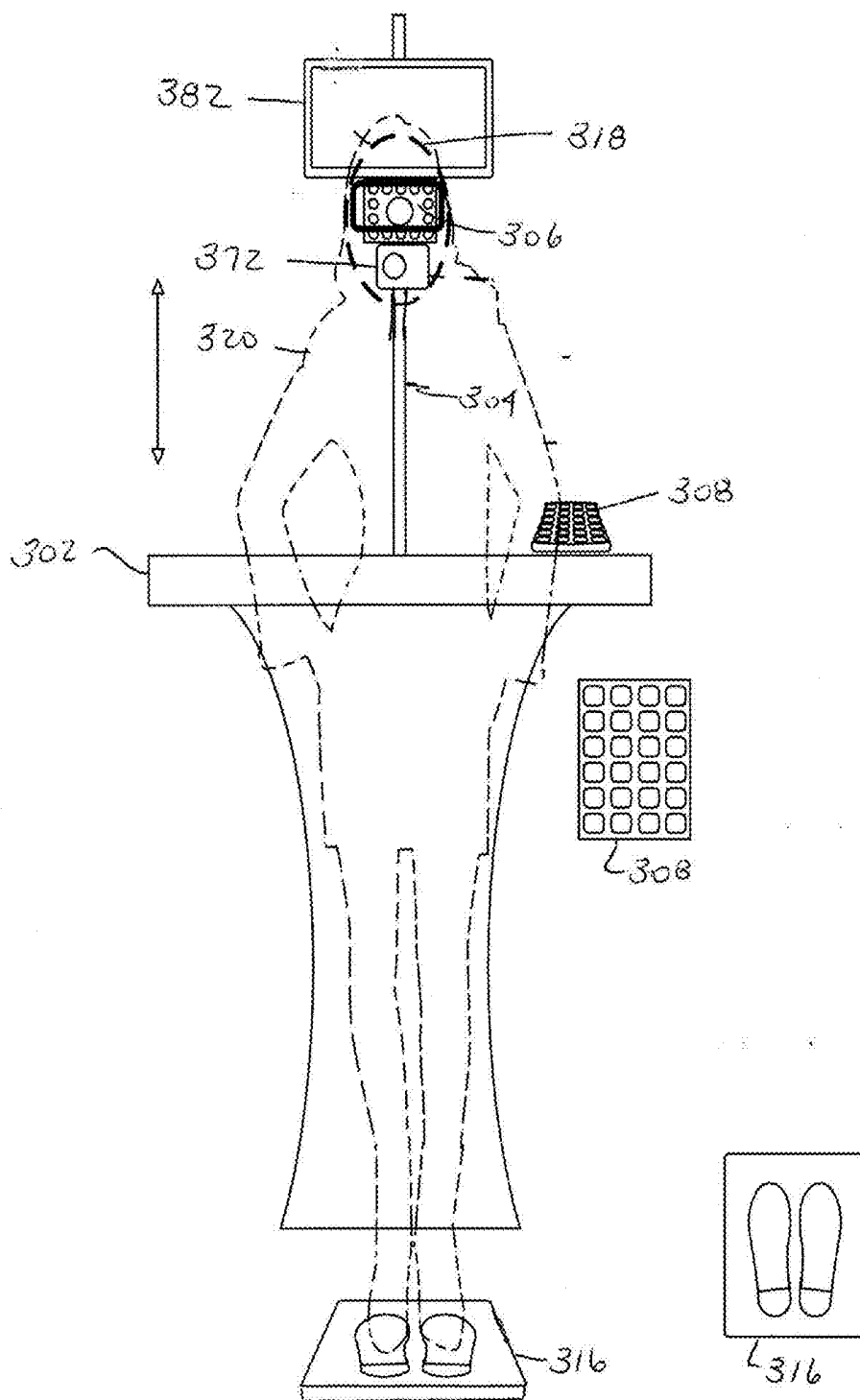
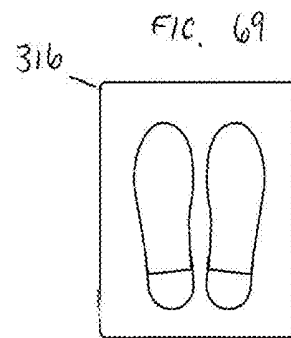
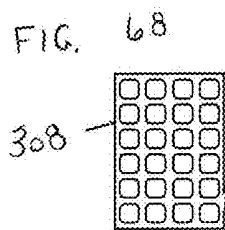
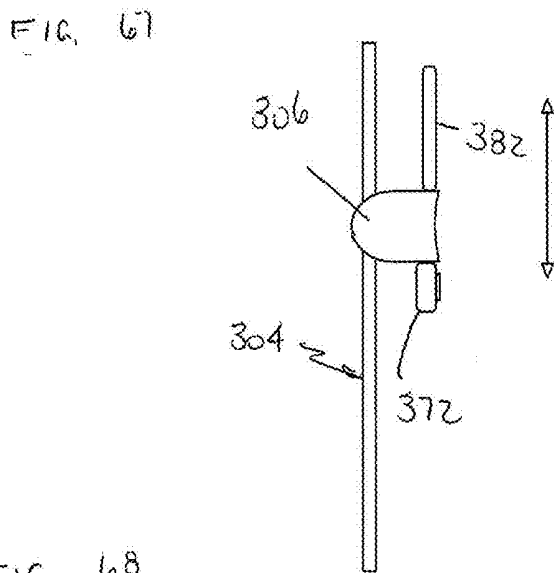
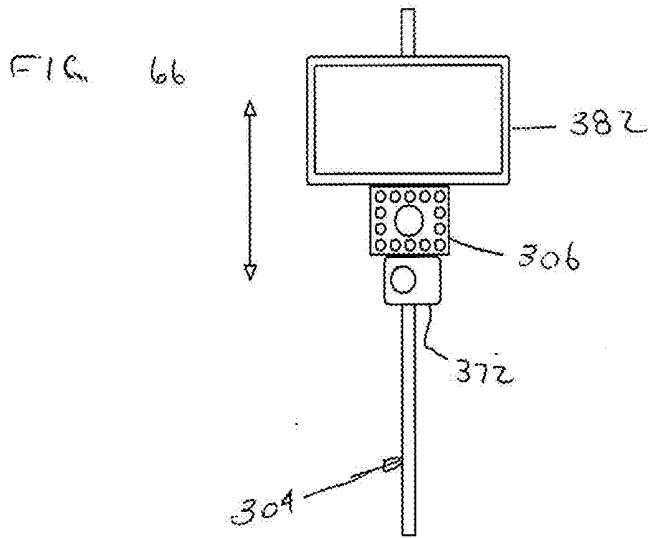


FIG. 65





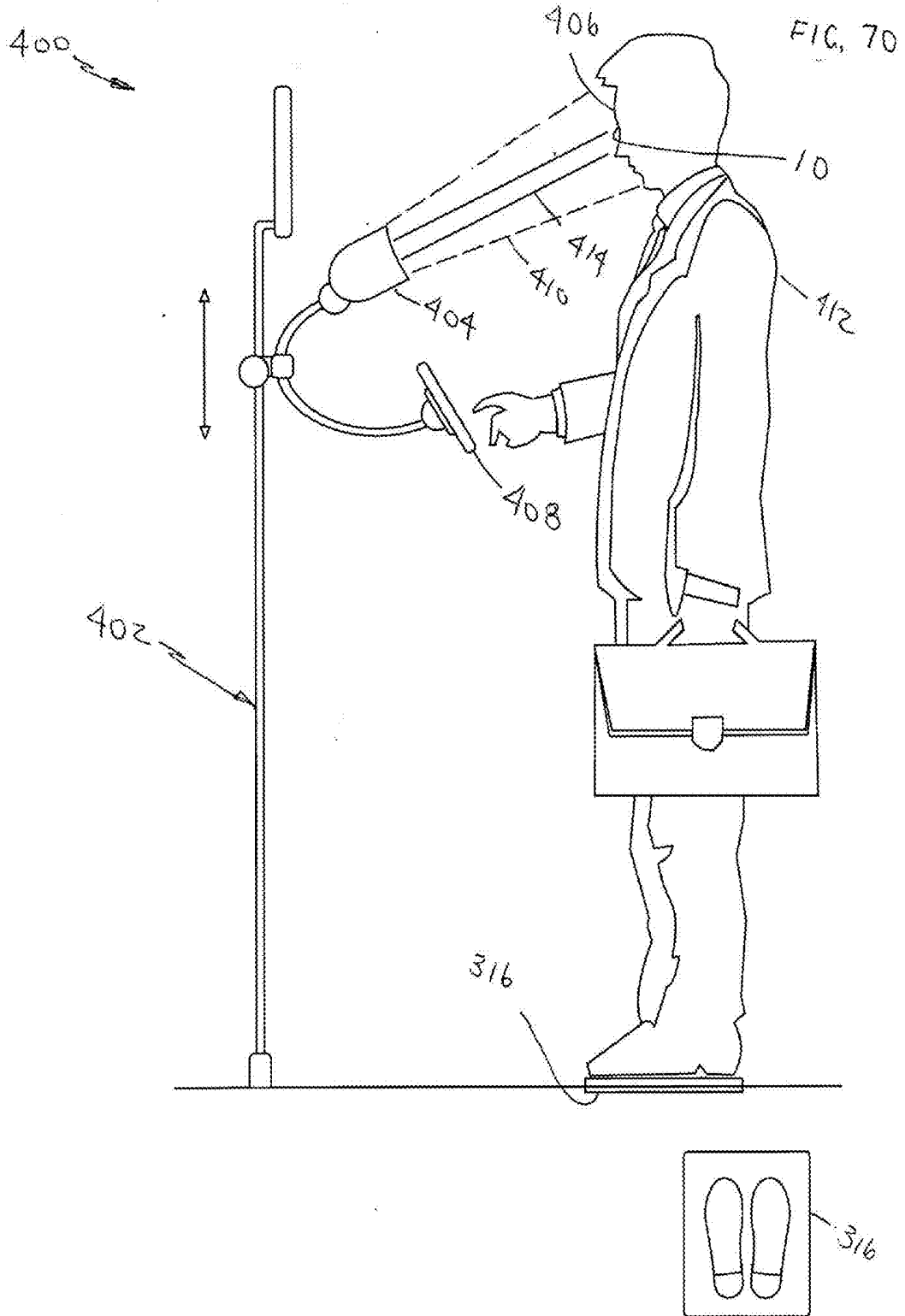


FIG. 70A

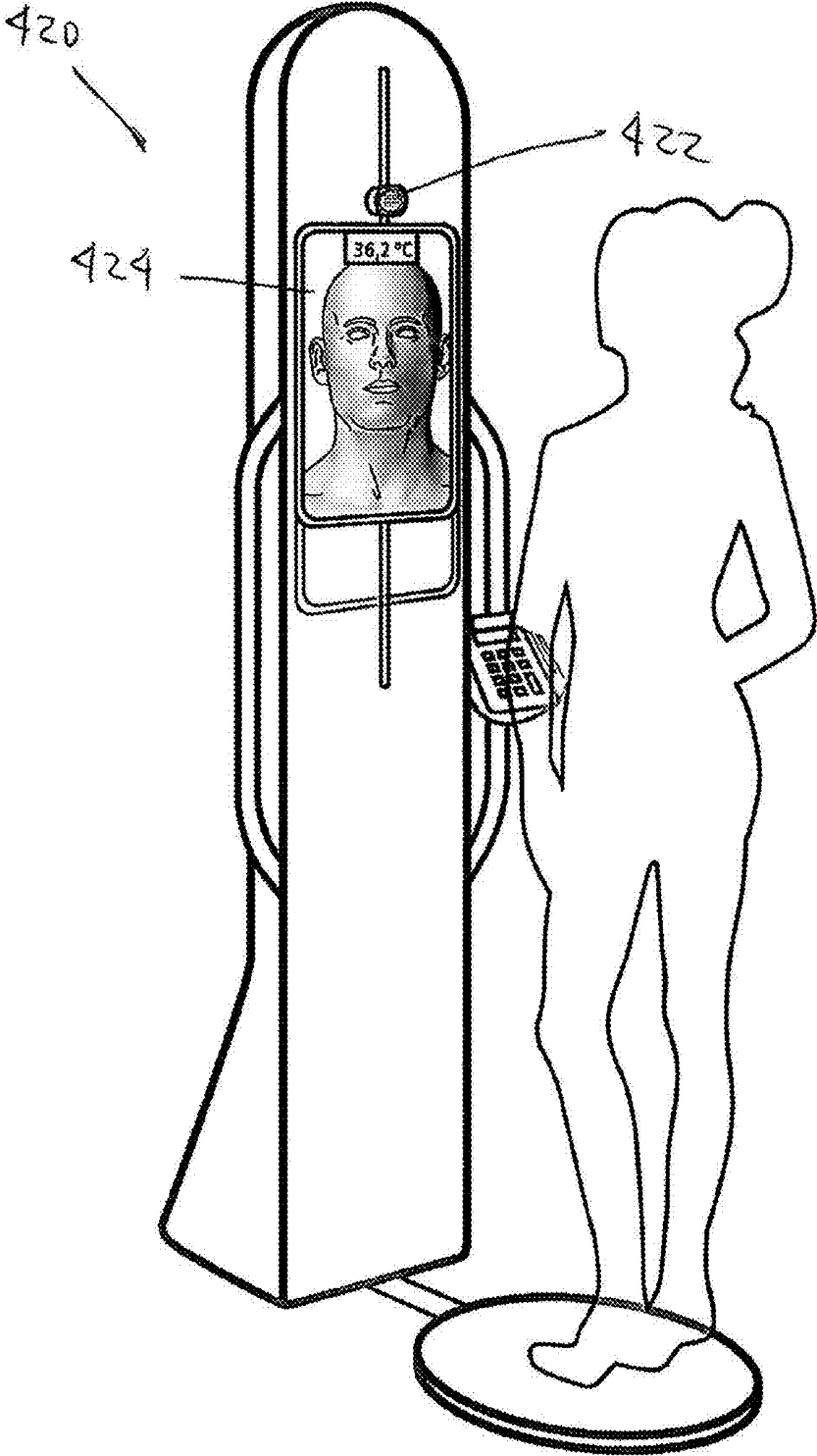


FIG. 70B

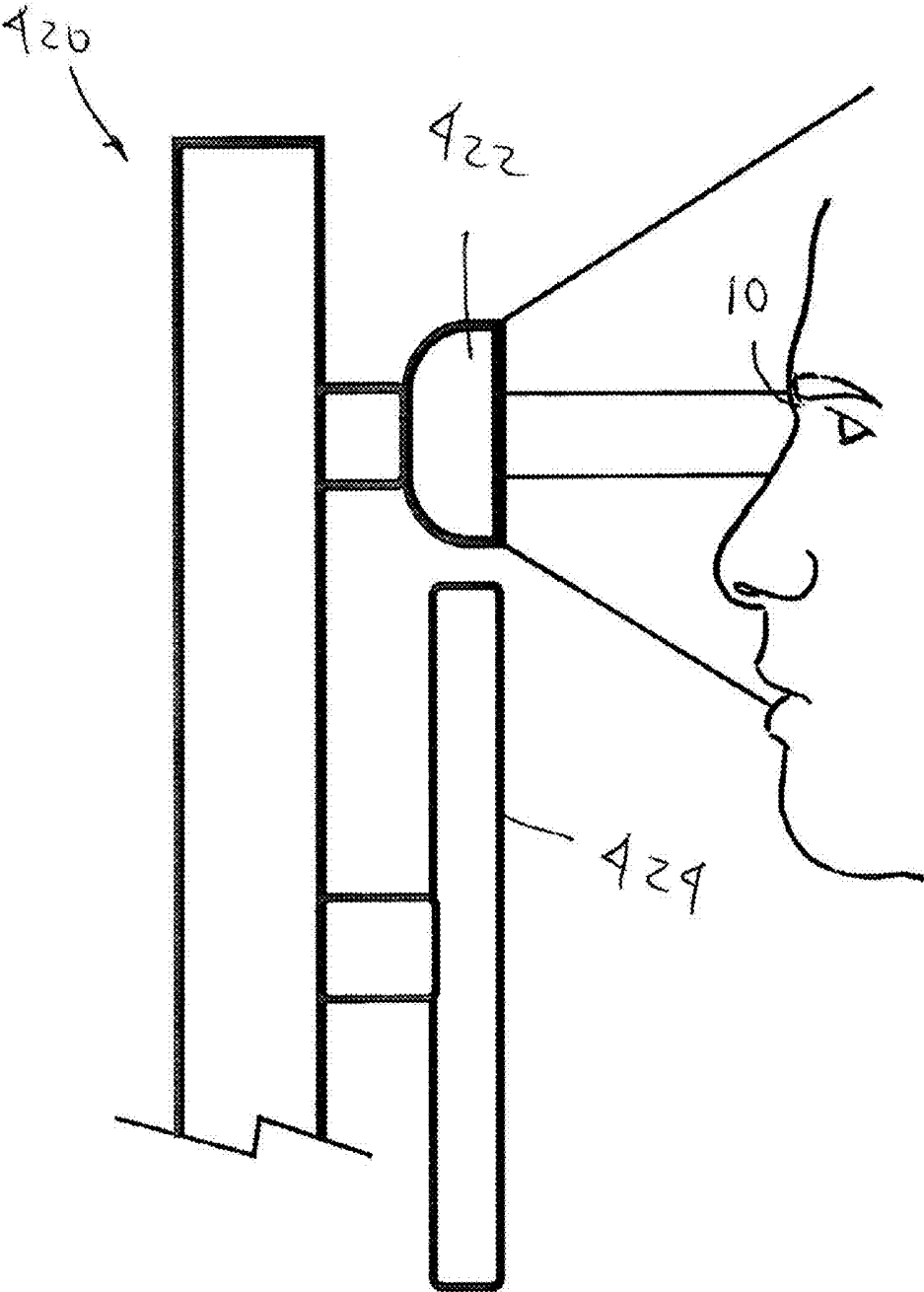


FIG. 70C

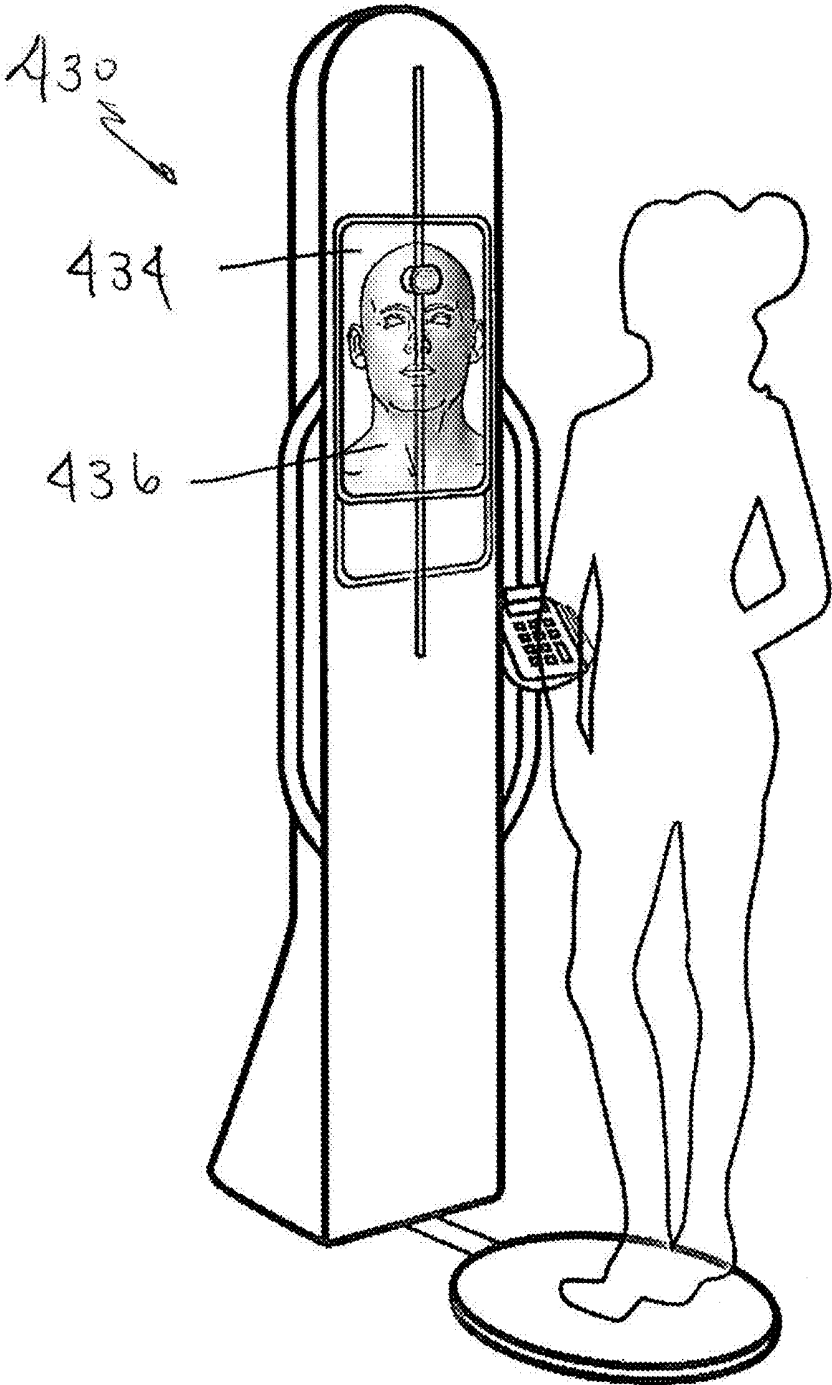


FIG. 70D

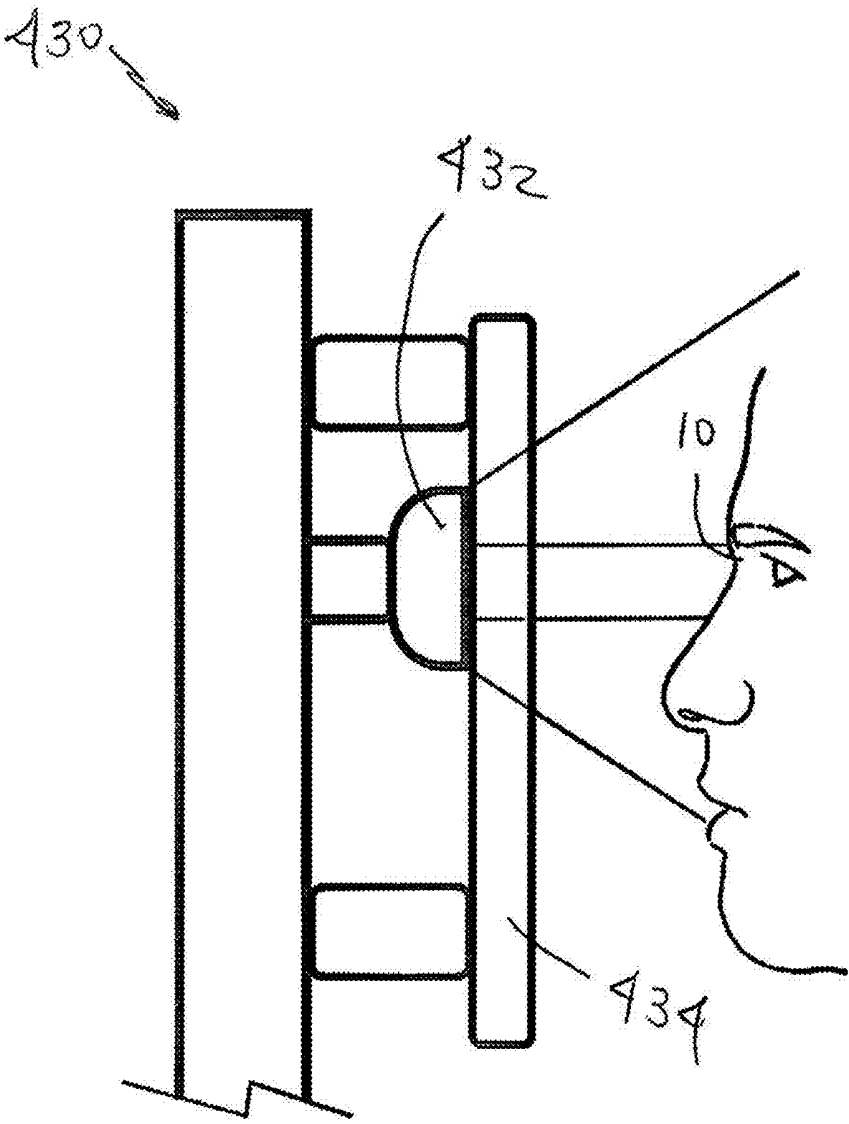


FIG. 70E

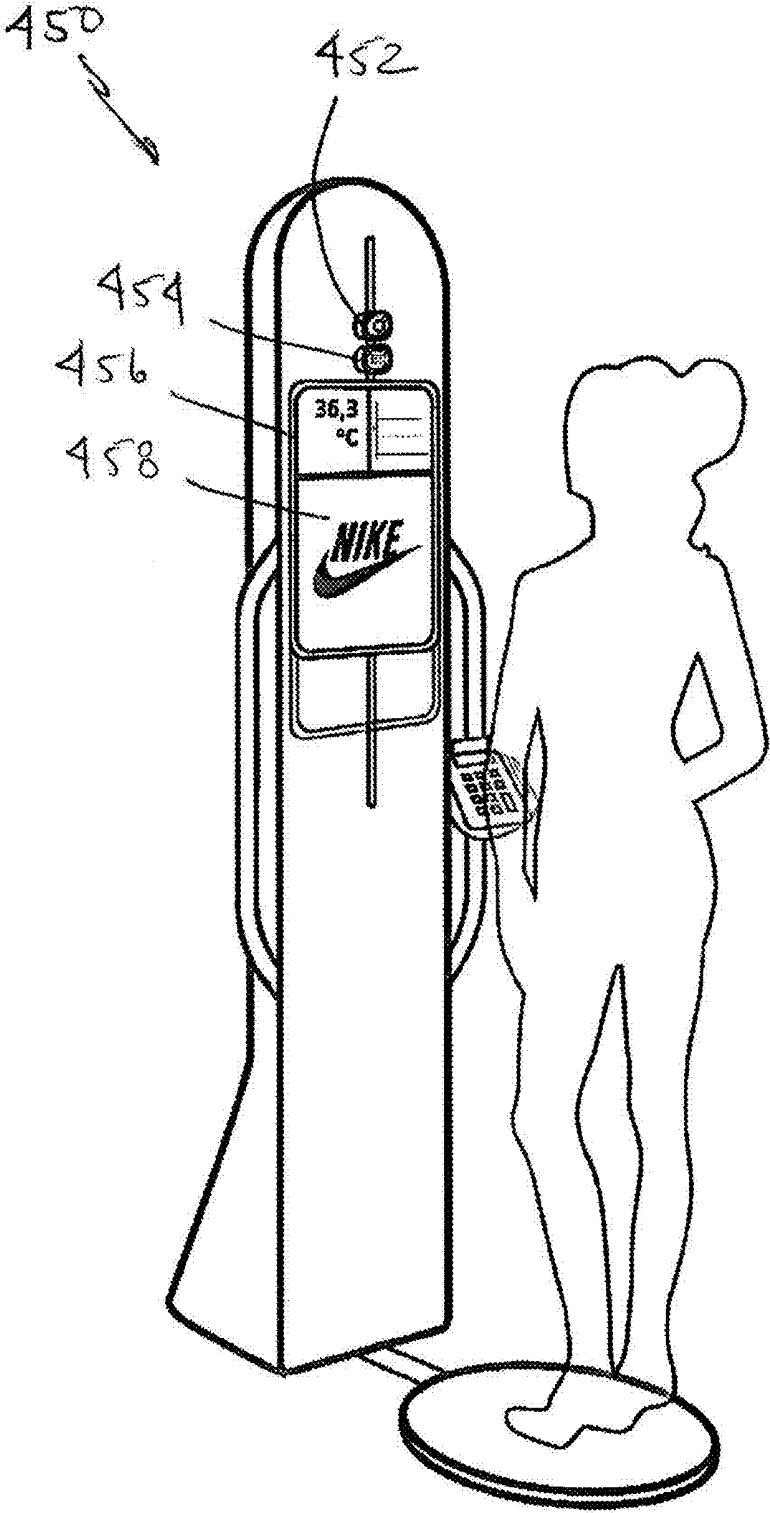


FIG. 70F

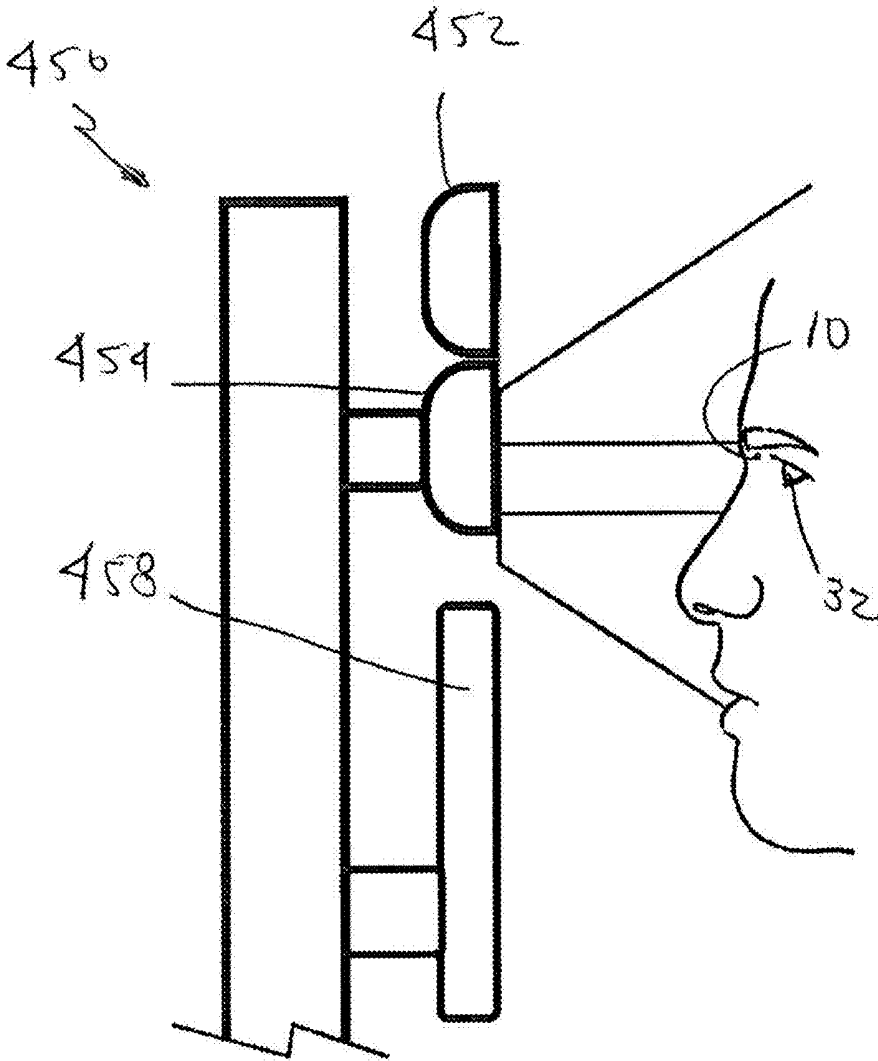


FIG. 70G

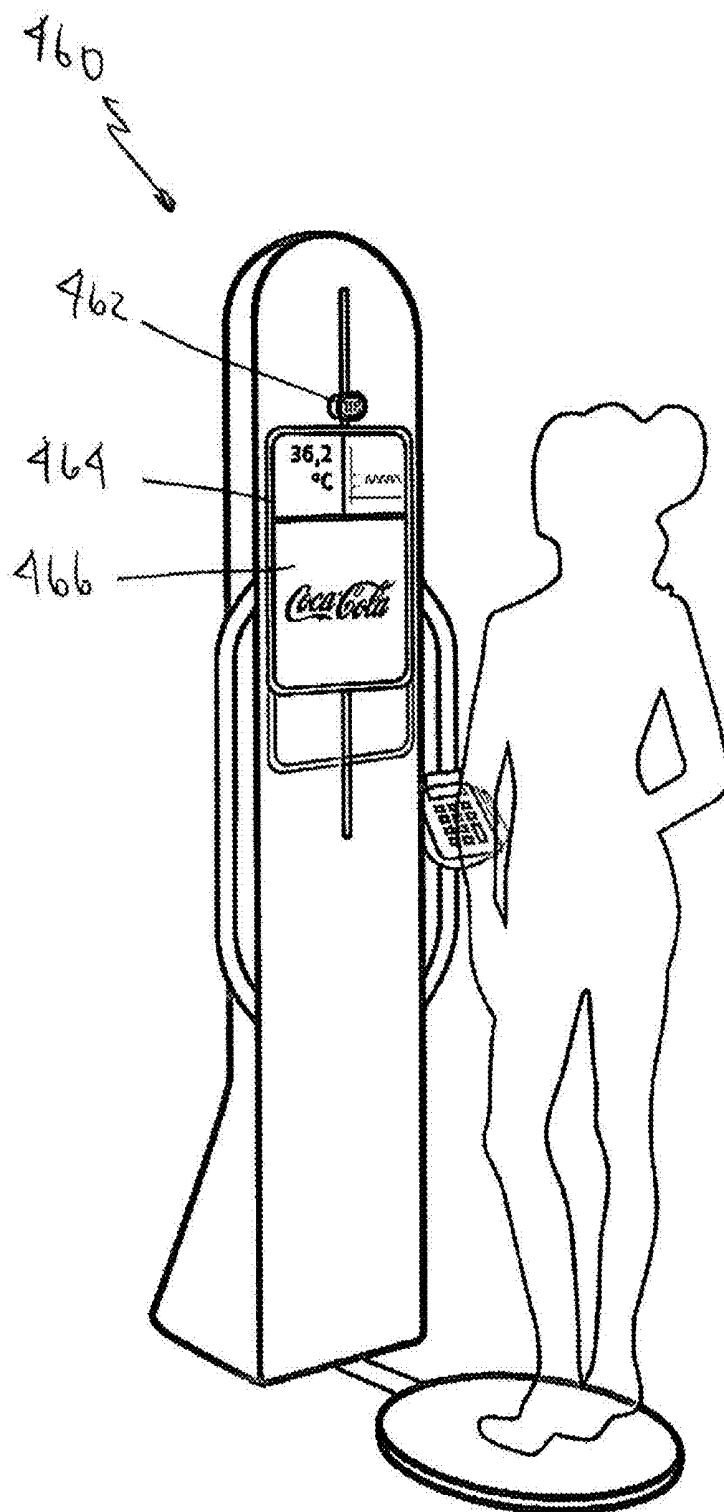


FIG. 70H

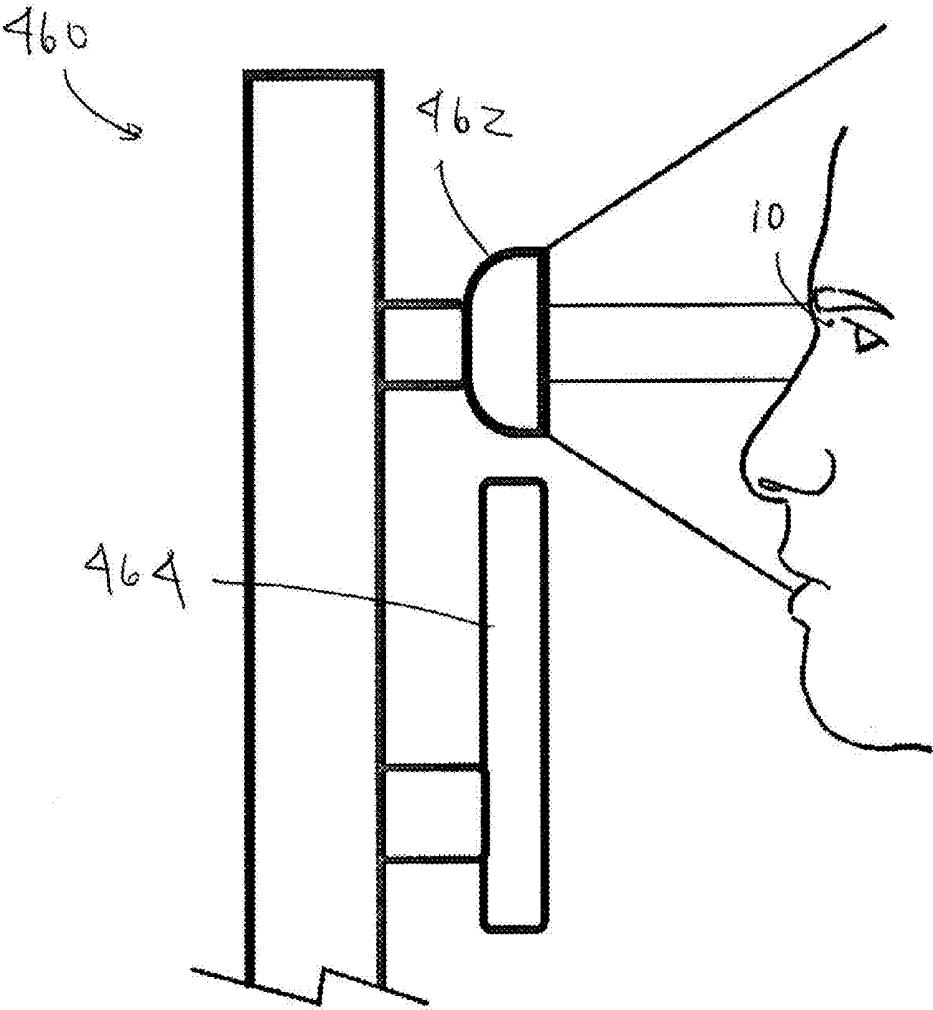


FIG. 70I

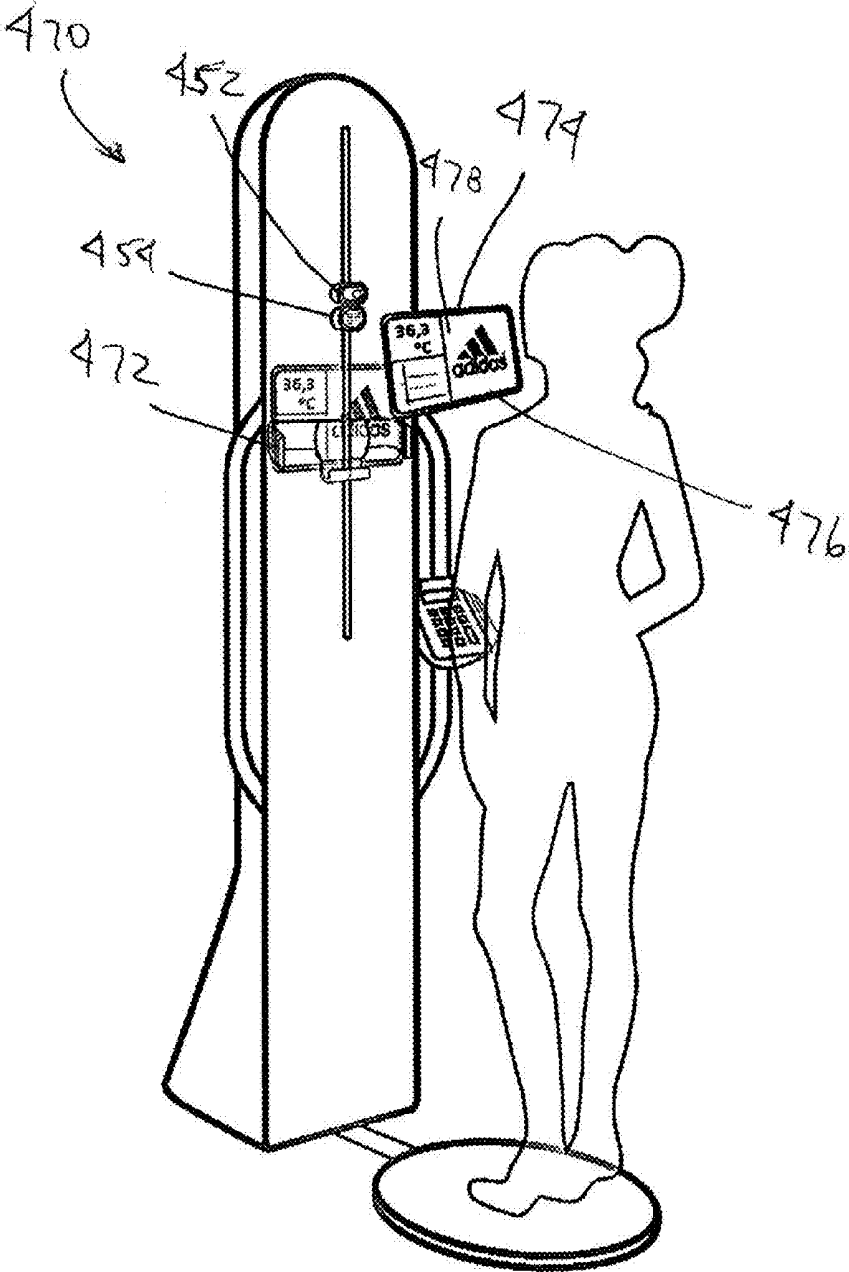


FIG. 70J

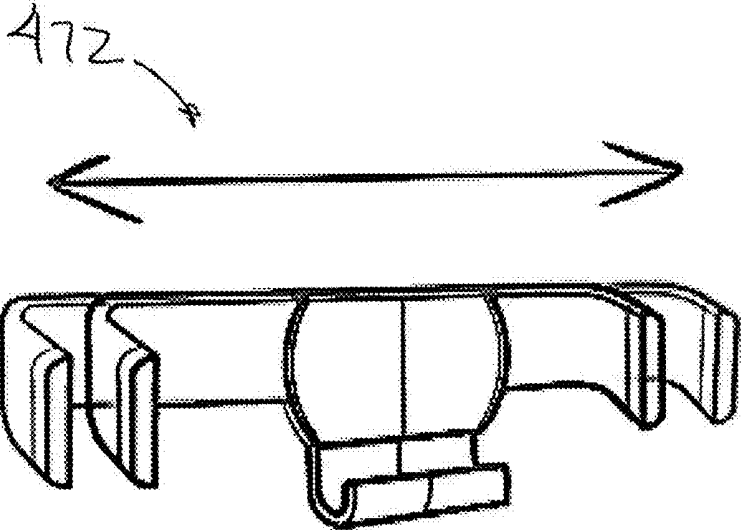
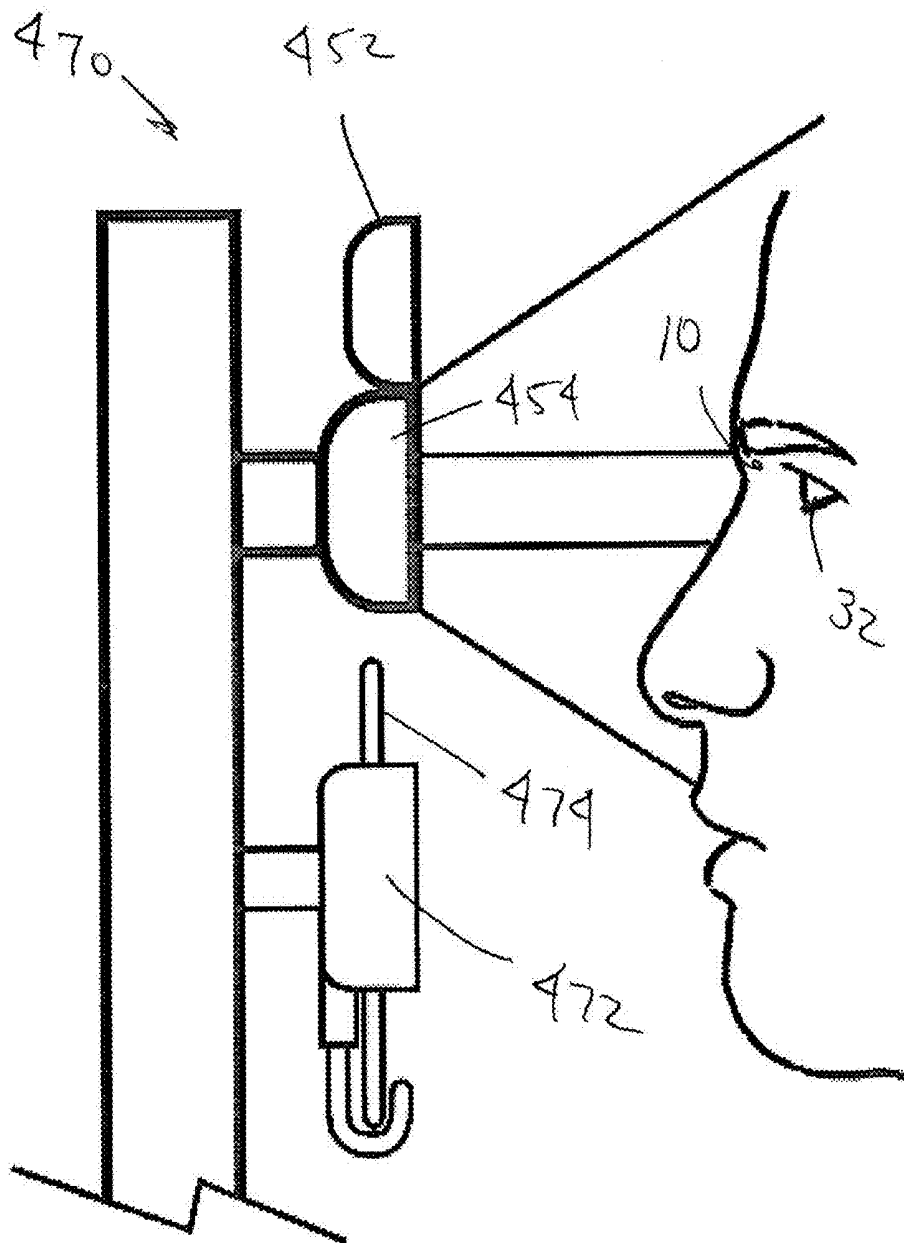
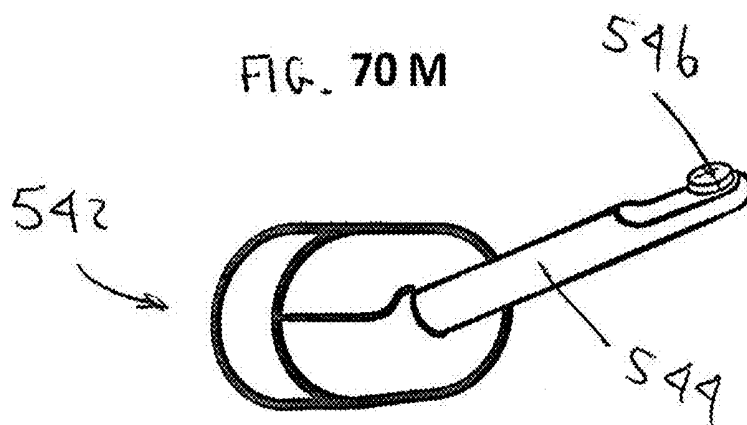
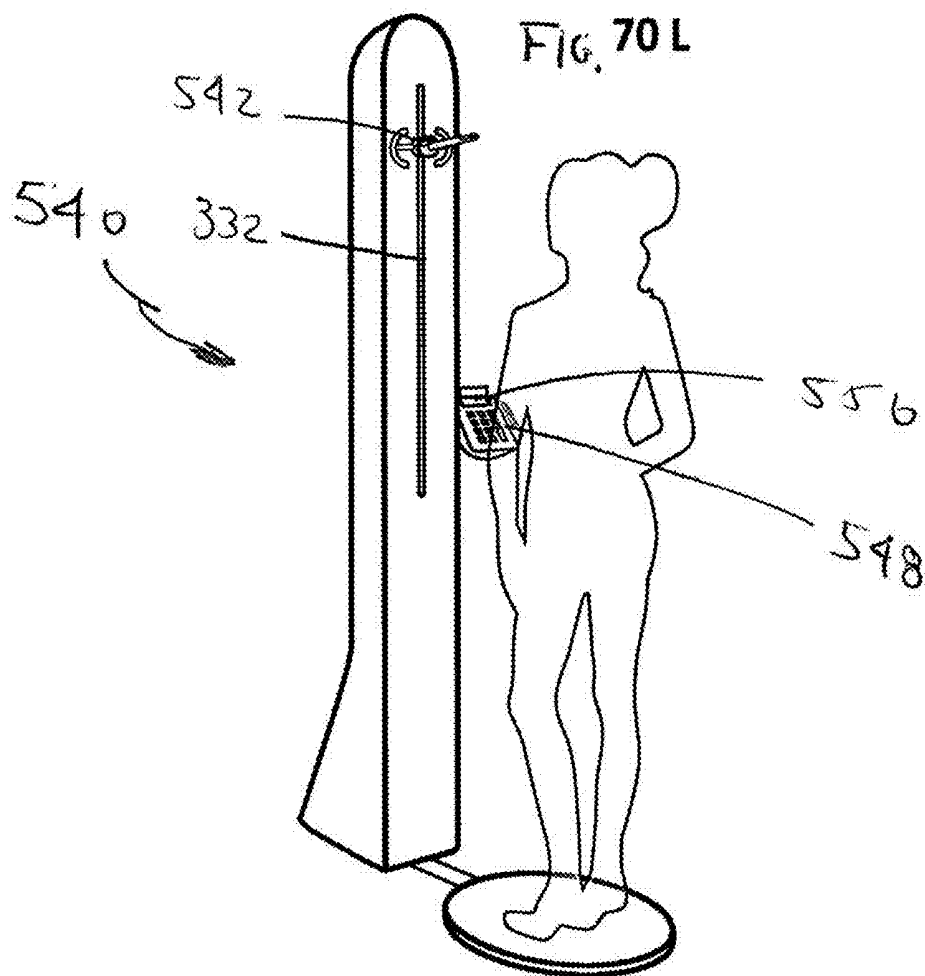
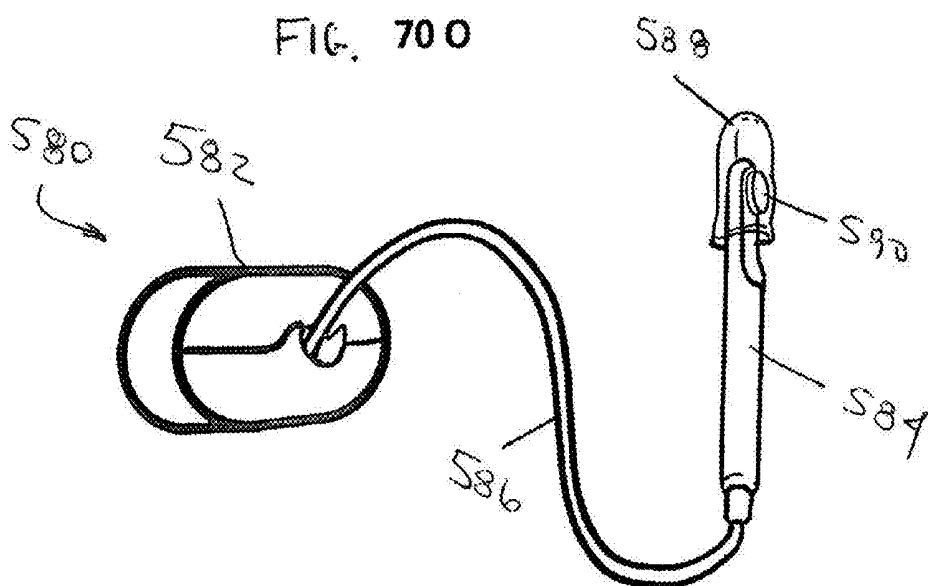
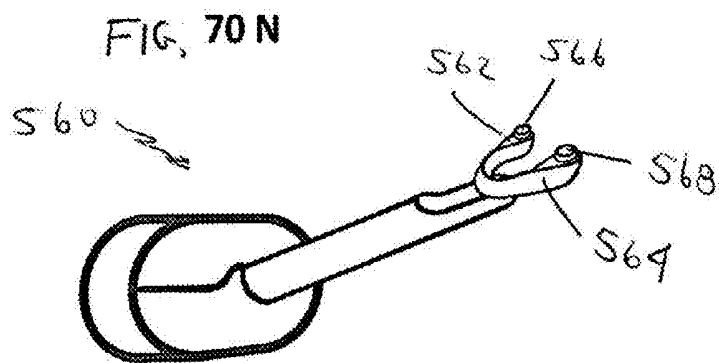


FIG. 70K







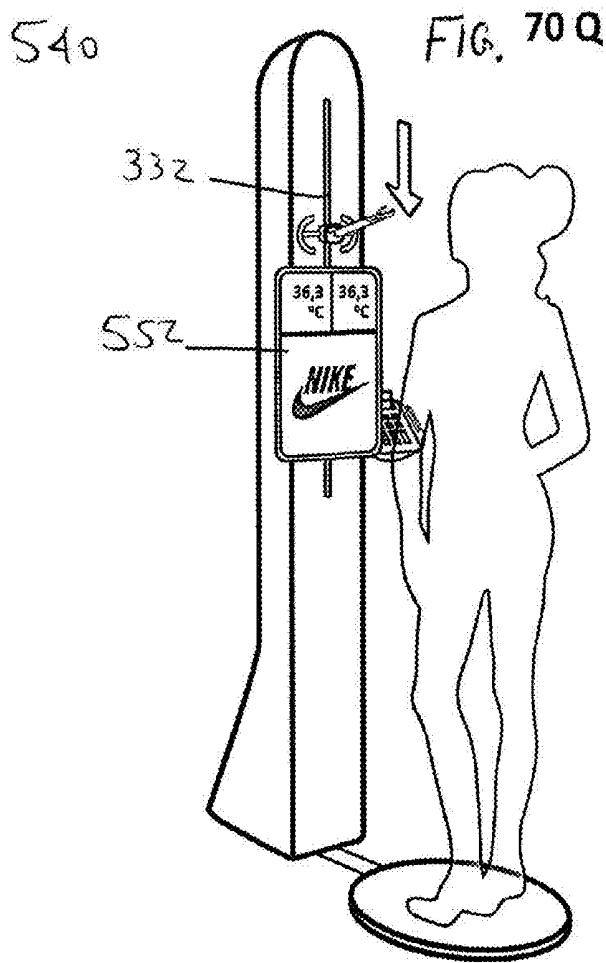
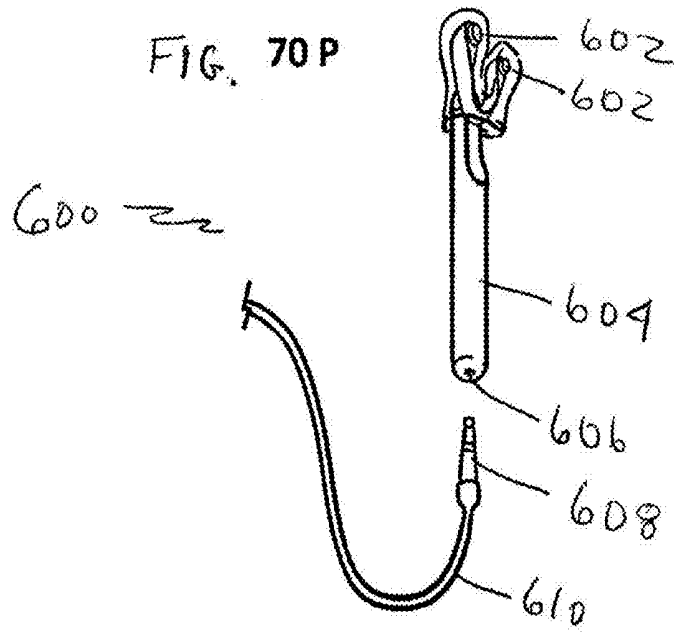
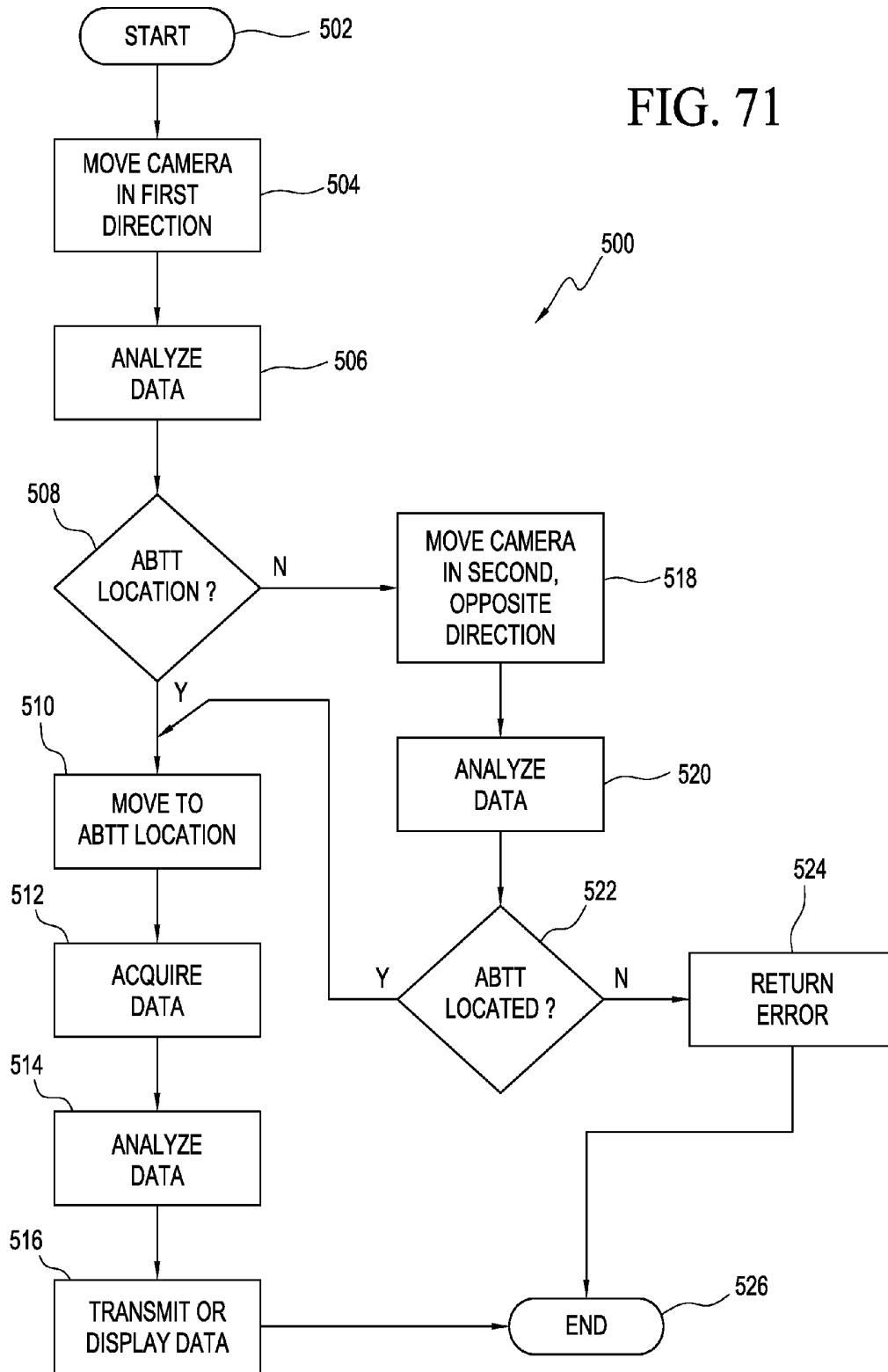


FIG. 71



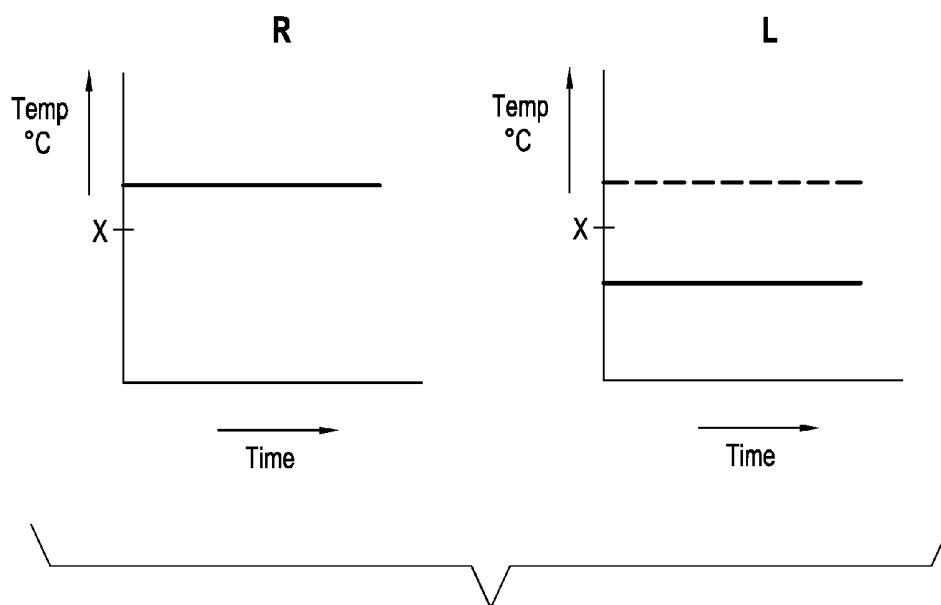


FIG. 72

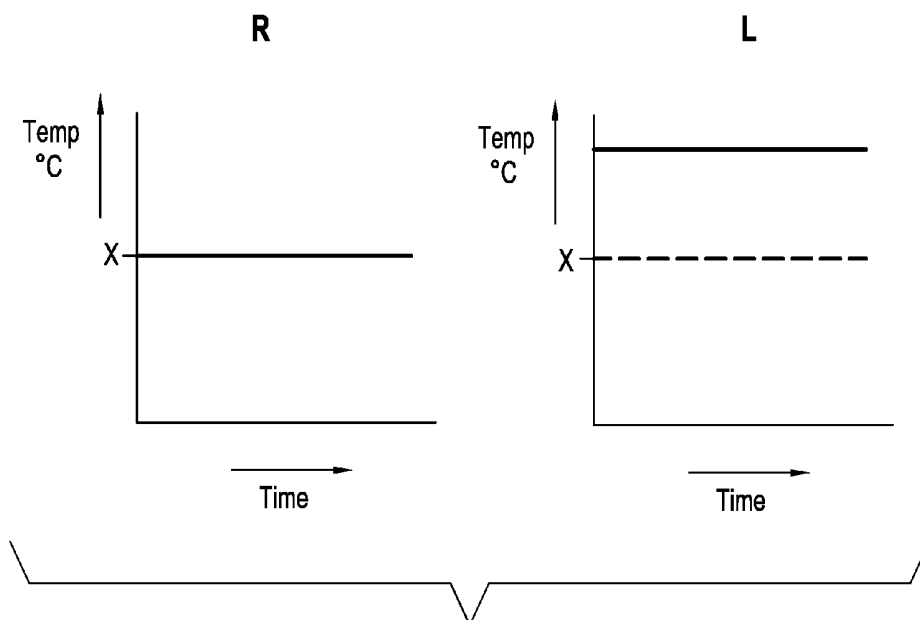


FIG. 73

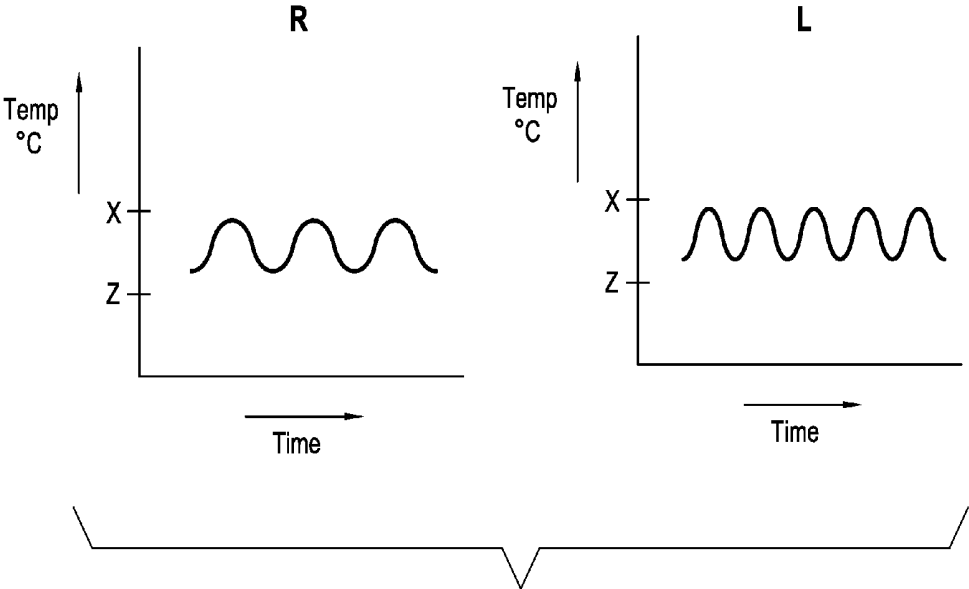


FIG. 74

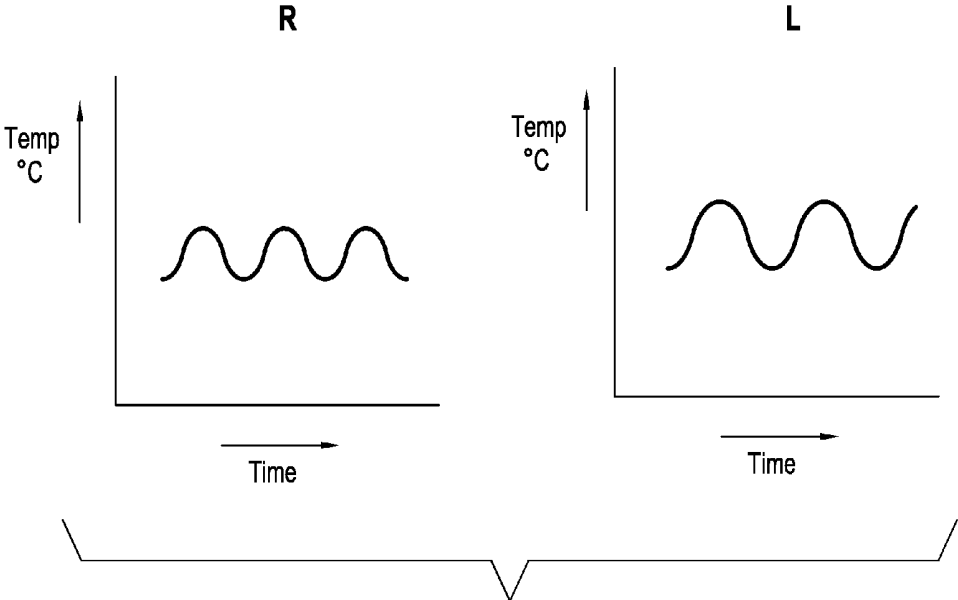


FIG. 75

FIG. 76

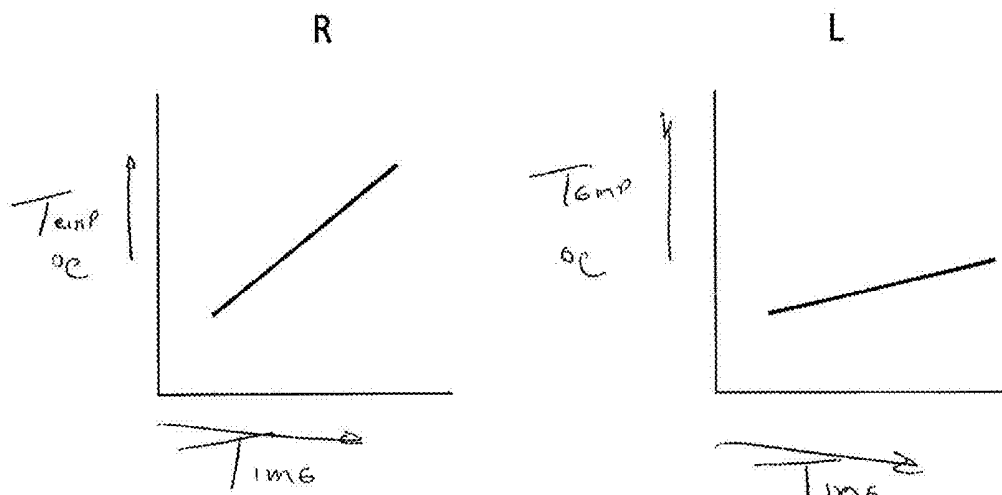
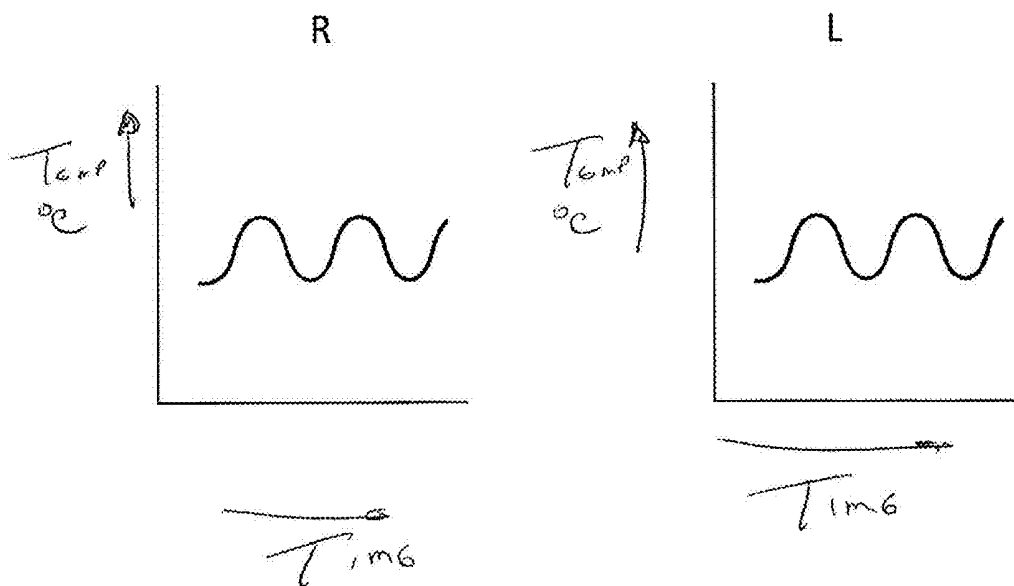


FIG. 77



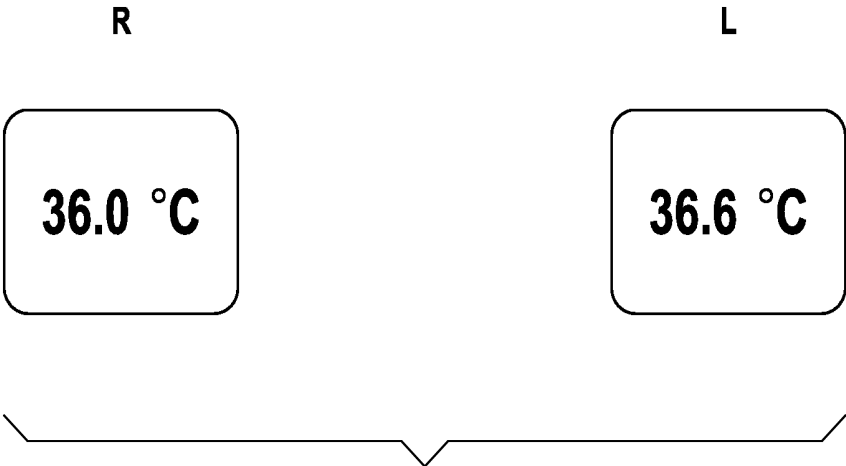


FIG. 78

**DEVICES, APPARATUSES, SYSTEMS, AND  
METHODS FOR MEASURING  
TEMPERATURE OF AN ABTT TERMINUS**

CROSS-REFERENCE TO RELATED  
APPLICATIONS

[0001] This application claims the benefit of priority to U.S. Provisional Patent Application No. 62/131,131, filed Mar. 10, 2015, which is incorporated herein by reference in its entirety.

TECHNICAL FIELD

[0002] This disclosure relates to devices configured to measure the temperature of one or more Abreu brain thermal tunnel (ABTT) terminuses.

BACKGROUND

[0003] Measurement of body temperature is conventionally accomplished by way of oral, axillary, forehead, or rectal thermometers.

SUMMARY

[0004] This disclosure provides a device for measuring a temperature of an Abreu brain thermal tunnel (ABTT). The device comprises a handle, a mirror, an arm, a temperature sensor positioned on the arm, and a display. The mirror includes a mirrored surface supported by the handle. The arm extends in a direction that is away from the mirror. The temperature sensor is sized and dimensioned to measure the temperature of an ABTT terminus. The temperature sensor is positioned on an end of the arm that is opposite from the mirror, and the temperature sensor is configured to provide a temperature measurement. The display is configured to receive and display the temperature measurement.

[0005] This disclosure also provides a device for locating an Abreu brain thermal tunnel (ABTT) and measuring thermal data from the ABTT. The device comprises a thermal imaging camera, a processor, and a display. The thermal imaging camera is configured to acquire a thermal image of a human face and to transmit the thermal image. The processor is configured to receive the transmitted thermal image, to analyze the thermal image to determine a location of an ABTT terminus, to then acquire thermal data from the ABTT terminus, to analyze the acquired thermal data, and to transmit the results of the analysis. The display is configured to receive the results of the analysis and to display the results of the analysis.

[0006] This disclosure also provides a device for measuring a temperature of two Abreu brain thermal tunnels (ABTT's). The device comprises a first rotatable member, a first thermal sensor, and a rotatable member. The first thermal sensor is positioned on the device and sized and dimensioned to measure a thermal output of a first ABTT terminus. The first thermal sensor is oriented in a first direction. The second thermal sensor is supported by the device and sized and dimensioned to measure a thermal output of a second ABTT terminus. The second thermal sensor is oriented in a second direction. The first rotatable member is configured to support the first thermal sensor and the first rotatable member is movable to vary the distance between the first thermal sensor and the second thermal sensor.

[0007] This disclosure also provides a system for measuring the emission of at least one Abreu brain thermal tunnel

terminus, the system comprising a sensor, a display, and a processor. The sensor is configured to receive the emissions and to transmit signals representative of the emissions during an interval of time. The processor is configured to receive the signal, to analyze the signal, and to provide an output representative of at least one of the signal and the analysis of the signal to the display. The processor is further configured to provide an output that includes an advertisement during the interval of time and during a time to receive the signal and to analyze the signal.

[0008] This disclosure also provides a method of acquiring, analyzing, and displaying data acquired from at least one Abreu brain thermal tunnel terminus. The method comprises receiving emissions from the at least one Abreu brain thermal tunnel terminus during an interval of time; transmitting signals representative of the emissions to a processor; analyzing the transmitted signals and presenting the results on a display; and displaying an advertisement during the interval of time.

[0009] Advantages and features of the embodiments of this disclosure will become more apparent from the following detailed description of exemplary embodiments when viewed in conjunction with the accompanying drawings.

BRIEF DESCRIPTION OF THE DRAWINGS

[0010] FIG. 1 shows a simplified view of the ABTT and facial veins associated with the ABTT.

[0011] FIG. 2 shows a simplified partial cross-sectional view through a human skull in a vertical direction, showing the Abreu brain thermal tunnel and certain other facial features.

[0012] FIG. 3 shows a stylized representation of the flow of blood into a brain core.

[0013] FIG. 4 shows a side view of a device configured to assist in locating an ABTT terminus and then measure the temperature at the ABTT terminus in accordance with an exemplary embodiment of the present disclosure.

[0014] FIG. 5 shows a perspective view of the device of FIG. 4.

[0015] FIG. 6 shows a front view of another device configured to assist in locating an ABTT terminus and then to measure the temperature of the ABTT terminus in accordance with an exemplary embodiment of the present disclosure.

[0016] FIG. 7 shows a side view of the device of FIG. 6.

[0017] FIG. 7A shows a view of yet another device configured to assist in locating the ABTT terminus and then to measure the temperature of the ABTT terminus in accordance with an exemplary embodiment of the present disclosure.

[0018] FIG. 7B shows another view of the device of FIG. 7A.

[0019] FIG. 7C shows a view of still yet another device configured to assist in locating the ABTT terminus and then to measure the temperature of the ABTT terminus in accordance with an exemplary embodiment of the present disclosure.

[0020] FIG. 7D shows another view of the device of FIG. 7C.

[0021] FIG. 7E shows a view of an even further device configured to assist in locating the ABTT terminus and then to measure the temperature of the ABTT terminus in accordance with an exemplary embodiment of the present disclosure.

[0022] FIG. 7F shows another view of the device of FIG. 7E.

[0023] FIG. 7G shows another view of the device of FIG. 7C.

[0024] FIG. 7H shows another view of the device of FIG. 7A.

[0025] FIG. 8 shows a view of yet another device configured to locate at least one ABTT terminus and then to measure the temperature of the at least one ABTT terminus, with the device in a first configuration, in accordance with an exemplary embodiment of the present disclosure.

[0026] FIG. 8A shows a view of yet an even further device configured to locate at least one ABTT terminus and then to measure the temperature of the at least one ABTT terminus in accordance with an exemplary embodiment of the present disclosure.

[0027] FIG. 8B shows a view of still an even further device configured to locate at least one ABTT terminus and then to measure the temperature of the at least one ABTT terminus in accordance with an exemplary embodiment of the present disclosure.

[0028] FIG. 9 shows another view of the device of FIG. 8, with the device in a second configuration.

[0029] FIG. 10 shows a side view of the device of FIG. 8.

[0030] FIG. 11 shows a perspective view of the device of FIG. 8.

[0031] FIG. 12 shows a view of a device configured to measure the temperature of at least one ABTT terminus, with the device in a first position, in accordance with an exemplary embodiment of the present disclosure.

[0032] FIG. 13 shows another view of the device of FIG. 12, with the device in a second position.

[0033] FIG. 14 shows a side view of the device of FIG. 12.

[0034] FIG. 15 shows a perspective view of the device of FIG. 12.

[0035] FIG. 16 shows a top view of another device configured to measure the temperature of at least one ABTT terminus, with the device positioned adjacent to a user's face, in accordance with an exemplary embodiment of the present disclosure.

[0036] FIG. 17 shows another view of the device of FIG. 16, showing a range of motion for portions of the device.

[0037] FIG. 18 shows a back view of the device of FIG. 16.

[0038] FIG. 19 shows a view of an apparatus configured to locate an ABTT terminus and then to measure the temperature of the ABTT terminus, in accordance with an exemplary embodiment of the present disclosure.

[0039] FIG. 20 shows a side view of the apparatus of FIG. 19.

[0040] FIG. 21 shows a view of another apparatus configured to locate an ABTT terminus and then to measure the temperature of the ABTT terminus, in accordance with an exemplary embodiment of the present disclosure.

[0041] FIG. 22 shows a side view of the apparatus of FIG. 21.

[0042] FIG. 23 shows a front view of yet another apparatus configured to locate an ABTT terminus and then to measure the temperature of the ABTT terminus, in accordance with an exemplary embodiment of the present disclosure.

[0043] FIG. 24 shows a side view of the apparatus of FIG. 23.

[0044] FIG. 25 shows a front view of a further apparatus configured to locate an ABTT terminus and then to measure the temperature of the ABTT terminus, in accordance with an exemplary embodiment of the present disclosure.

[0045] FIG. 26 shows a side view of the apparatus of FIG. 25.

[0046] FIG. 27 shows a front view of a still further apparatus configured to locate an ABTT terminus and then to measure the temperature of the ABTT terminus, in accordance with an exemplary embodiment of the present disclosure.

[0047] FIG. 28 shows a side view of the apparatus of FIG. 27.

[0048] FIG. 29 shows a front view of an even further apparatus configured to locate an ABTT terminus and then to measure the temperature of the ABTT terminus, in accordance with an exemplary embodiment of the present disclosure.

[0049] FIG. 30 shows a side view of the apparatus of FIG. 29.

[0050] FIG. 30A shows a view of the device of FIGS. 7C and 7D positioned on a swing arm support apparatus.

[0051] FIG. 30B shows another view of the device of FIG. 30A.

[0052] FIG. 30C shows a view of a screw-based mounting mechanism for the apparatus of FIG. 30A.

[0053] FIG. 30D shows a view of the device of FIGS. 7C and 7D positioned on a telescoping support.

[0054] FIG. 30E shows a view of another device positioned on the telescoping support in accordance with an exemplary embodiment of the present disclosure.

[0055] FIG. 31 shows a view of a system configured to locate an ABTT terminus and then to measure the temperature of the ABTT terminus, in accordance with an exemplary embodiment of the present disclosure.

[0056] FIG. 32 shows another view of the system of FIG. 31.

[0057] FIG. 33 shows a further view of the system of FIG. 31.

[0058] FIG. 33A shows a view of another system configured to locate an ABTT terminus and then to measure the temperature of the ABTT terminus, in accordance with an exemplary embodiment of the present disclosure.

[0059] FIG. 33B shows a view of a card reader of the system of FIG. 33A.

[0060] FIG. 34 shows a view of a support structure for the system of FIG. 31, in accordance with an exemplary embodiment of the present disclosure.

[0061] FIG. 35 shows a side view of the support structure of FIG. 34.

[0062] FIG. 36 shows a view of an alternative embodiment support structure for the system of FIG. 31, in accordance with an exemplary embodiment of the present disclosure.

[0063] FIG. 37 shows a side view of the support structure of FIG. 36.

[0064] FIG. 38 shows a view of another system configured to locate an ABTT terminus and then to measure the temperature of the ABTT terminus, in accordance with an exemplary embodiment of the present disclosure.

[0065] FIG. 39 shows another view of the system of FIG. 38.

[0066] FIG. 40 shows a view of a support structure for the system of FIG. 38, in accordance with an exemplary embodiment of the present disclosure.

[0067] FIG. 41 shows a side view of the support structure of FIG. 40.

[0068] FIG. 42 shows a view of a device to control a camera position of the system of FIG. 38.

[0069] FIG. 43 shows a view of a further system configured to locate an ABTT terminus and then to measure the tempera-

ture of the ABTT terminus, in accordance with an exemplary embodiment of the present disclosure.

[0070] FIG. 44 shows another view of the system of FIG. 43.

[0071] FIG. 45 shows a further view of the system of FIG. 43.

[0072] FIG. 46 shows a view of a support structure for the system of FIG. 43, in accordance with an exemplary embodiment of the present disclosure.

[0073] FIG. 47 shows a side view of the support structure of FIG. 46.

[0074] FIG. 48 shows a view of a device to control a camera position of the system of FIG. 43.

[0075] FIG. 49 shows a view of an even further system configured to locate an ABTT terminus and then to measure the temperature of the ABTT terminus, in accordance with an exemplary embodiment of the present disclosure.

[0076] FIG. 50 shows another view of the system of FIG. 49.

[0077] FIG. 51 shows a further view of the system of FIG. 49.

[0078] FIG. 52 shows a view of a support structure for the system of FIG. 49, in accordance with an exemplary embodiment of the present disclosure.

[0079] FIG. 53 shows a side view of the support structure of FIG. 52.

[0080] FIG. 54 shows a view of a device to control a camera position of the system of FIG. 49.

[0081] FIG. 55 shows a view of an activation device of the system of FIG. 49.

[0082] FIG. 56 shows a view of a still further system configured to locate an ABTT terminus and then to measure the temperature of the ABTT terminus, in accordance with an exemplary embodiment of the present disclosure.

[0083] FIG. 57 shows another view of the system of FIG. 56.

[0084] FIG. 58 shows a further view of the system of FIG. 56.

[0085] FIG. 59 shows a view of a support structure for the system of FIG. 56, in accordance with an exemplary embodiment of the present disclosure.

[0086] FIG. 60 shows a side view of the support structure of FIG. 59.

[0087] FIG. 61 shows a view of a device to control a camera position of the system of FIG. 56.

[0088] FIG. 62 shows a view of an activation device of the system of FIG. 56.

[0089] FIG. 63 shows a view of yet an even further system configured to locate an ABTT terminus and then to measure the temperature of the ABTT terminus, in accordance with an exemplary embodiment of the present disclosure.

[0090] FIG. 64 shows another view of the system of FIG. 63.

[0091] FIG. 65 shows a further view of the system of FIG. 63.

[0092] FIG. 66 shows a view of a support structure for the system of FIG. 63, in accordance with an exemplary embodiment of the present disclosure.

[0093] FIG. 67 shows a side view of the support structure of FIG. 66.

[0094] FIG. 68 shows a view of a device to control a camera position of the system of FIG. 63.

[0095] FIG. 69 shows a view of an activation device of the system of FIG. 63.

[0096] FIG. 70 shows a view of another system configured to locate an ABTT terminus and then to measure the temperature of the ABTT terminus, in accordance with an exemplary embodiment of the present disclosure.

[0097] FIG. 70A shows a view of yet another system configured to locate an ABTT terminus and then to measure the temperature of the ABTT terminus, in accordance with an exemplary embodiment of the present disclosure.

[0098] FIG. 70B shows a view of a portion of the system of FIG. 70A.

[0099] FIG. 70C shows a view of still yet another system configured to locate an ABTT terminus and then to measure the temperature of the ABTT terminus, in accordance with an exemplary embodiment of the present disclosure.

[0100] FIG. 70D shows a view of a portion of the system of FIG. 70C.

[0101] FIG. 70E shows a view of an even further system configured to locate an ABTT terminus and then to measure the temperature of the ABTT terminus, in accordance with an exemplary embodiment of the present disclosure.

[0102] FIG. 70F shows a view of a portion of the system of FIG. 70E.

[0103] FIG. 70G shows a view of an even further system configured to locate an ABTT terminus and then to measure the temperature of the ABTT terminus, in accordance with an exemplary embodiment of the present disclosure.

[0104] FIG. 70H shows a view of a portion of the system of FIG. 70G.

[0105] FIG. 70I shows a view of an even further system configured to locate an ABTT terminus and then to measure the temperature of the ABTT terminus, in accordance with an exemplary embodiment of the present disclosure.

[0106] FIG. 70J shows a view of a clamp of FIG. 70I.

[0107] FIG. 70K shows a view of a portion of the system of FIG. 70I.

[0108] FIG. 70L shows a view of a system configured to locate an ABTT terminus and then to measure the temperature of the ABTT terminus, in accordance with an exemplary embodiment of the present disclosure.

[0109] FIG. 70M shows a view of a sensor device of the system of FIG. 70L.

[0110] FIG. 70N shows a view of another sensor device in accordance with an exemplary embodiment of the present disclosure.

[0111] FIG. 70O shows a view of a further sensor device in accordance with an exemplary embodiment of the present disclosure.

[0112] FIG. 70P shows a view of an even further sensor device in accordance with an exemplary embodiment of the present disclosure.

[0113] FIG. 70Q shows a view of the system of FIG. 70L with modified features.

[0114] FIG. 71 shows an ABTT acquisition process in accordance with an exemplary embodiment of the present disclosure.

[0115] FIG. 72 shows a graph of ABTT temperatures showing a risk of aneurysm.

[0116] FIG. 73 shows a graph of ABTT temperatures showing a risk of cancer.

[0117] FIG. 74 shows a graph of ABTT temperatures showing a risk of seizures.

[0118] FIG. 75 shows a graph of ABTT temperatures showing a progression of infection.

[0119] FIG. 76 shows a graph of ABTT temperatures indicating Alzheimer's disease or spread of Alzheimer's disease beyond the hippocampus.

[0120] FIG. 77 shows a graph of ABTT temperatures indicating a risk of abscess.

[0121] FIG. 78 shows a numerical display of ABTT temperatures indicating a risk of stroke.

#### SUMMARY

[0122] The present disclosure arises from the discovery that an Abreu brain thermal tunnel or ABTT provides the first known means of vascular communication directly with the center of the brain. Anatomically and physiologically speaking, and as shown in FIGS. 1-3, ABTT 12 includes a continuous, direct, and undisturbed connection between a brain core 24 at the control center of the brain and an ABTT terminus 10. The physical and physiological events at one end of the tunnel are reproduced at the opposite end. ABTT 12 enables the direct communication of thermal energy between ABTT terminus 10 and brain core 24 without significant barriers. Accordingly, the present disclosure describes apparatus, systems, devices, mechanisms, and methods that are used to locate ABTT terminus 10 and then to measure the temperature of ABTT terminus 10.

[0123] Applicant has disclosed other devices, apparatuses, and systems for the measurement of temperature at ABTT terminus 10 in co-pending U.S. patent application Ser. Nos. 14/512,421, 14/593,848, 14/594,122, and 14/603,353. The present apparatuses, systems, devices, mechanisms, and methods described herein provide additional features and advantages, as will be understood by a person of skill in the art from reading the description provided herein.

[0124] The facial end of ABTT 12, herein referred to as target area, or terminus 10 on the skin on, over, or adjacent to ABTT 12, measures about 11 mm in diameter measured from the medial corner of an eye 32 at the medial canthal tendon and extends superiorly for about 6 mm, and then extends into the upper eyelid in a horn-like projection for another 22 mm.

[0125] Anatomy shows the convergence of four veins at ABTT target area 10: frontal 14, superior palpebral 16, supraorbital 18, and angular 20. As angular vein 20 extends further from ABTT 12, it transitions into facial vein 22. Having converged, the blood from these veins flows toward brain core 24 from ABTT target area 10 near the canthal corner of eye 32 into the center of the brain, which is the temperature center or thermal storage area of the body. FIGS. 1 and 2 show the approximate location of these veins in relation to other facial features. Angular/facial vein 20/22 runs up alongside nose 26, superior palpebral vein 16 runs along eyebrow 28, and frontal vein 14 and supraorbital vein 18 run through forehead 30.

[0126] As described herein, veins 14, 16, 18, 20, and 22 converge in the medial canthal area between the corner of eye 32 and the bridge of the nose and connect directly, without inhibition, to the center of the brain. These vessels lack valves, which are typically an important barrier to measurement of temperature in a core location of the brain in the hypothalamic region of the brain. The hypothalamic region of the brain is the link between the central nervous system and the endocrine system and, as such, acts as the center of control for many basic bodily functions such as, for example, hunger, thirst, body temperature, fatigue, blood pressure, immune responses, circadian cycles, hormone production and secretion, and many others.

[0127] Referring to FIGS. 4 and 5, an ABTT temperature measurement device in accordance with an exemplary embodiment of the present disclosure is shown and indicated generally at 50. Device 50 includes a handle 52 that is configured to support a mirror 54, which includes a partially reflecting mirrored or reflective surface 56. Device 50 is further configured to include a display 58, which can be positioned behind reflective surface 56, which is partially reflecting to permit light to travel through reflective surface 56 to enable display 58 to be seen by a user, when display 58 is illuminated.

[0128] Device 50 is also configured to include an arm 60 that extends in a direction that is away from mirrored or reflective surface 56, and is preferably at an angle with respect to surface 56 that matches an angle of ABTT terminus 10. While arm 60 is shown extending from surface 56 in FIGS. 4 and 5, in another exemplary embodiment arm 60 is configured to extend from handle 52. Arm 60 is configured to include a temperature sensor 62 at an end thereof, and the size and dimension of arm 60 is such that temperature sensor 62 is positioned near a center of mirrored surface 56 to enable the user to more easily use mirrored surface 56 to assist in positioning temperature sensor 62 at, near, on, adjacent, close, or alongside ABTT terminus 10. Device 50 further includes a switch 64, which can be located on handle 52. Switch 64 is configured to operate temperature sensor 62, with a resulting temperature measurement being presented on display 58. It should be understood that other sensors besides temperature can be used including infrared detector coupled to an emitter.

[0129] Device 50 can also be configured to include a light source such as a collimated LED 66 configured to emit visible light; i.e., a visible output. LED 66 is located in an LED housing 68, which can be positioned on arm 60. Switch 64 can be configured as a rocker-type switch that operates LED 66 in a first position, and operates LED 66 and temperature sensor 62 in a second position. Display 58 is operated automatically as a result of the operation of LED 66 and temperature sensor 62.

[0130] In operation, a user grasps handle 52, and by using mirror 54, positions temperature sensor 62 in an area that is adjacent to, meaning over or next to, ABTT terminus 10. In an exemplary embodiment, temperature sensor 62 can be a non-contact sensor, such as an infrared sensor, or can be a contact sensor, such as a thermocouple or thermopile, or an optical sensor or a dielectric sensor. If optional LED 66 is available, the user can press switch 64 to activate LED 66, which is boresighted or aligned with arm 60 such that light output from LED 66, as seen via mirror 54, can serve as a guide for positioning temperature sensor 62. Once temperature sensor 62 is properly placed, switch 64 may be moved to actuate temperature sensor 62. LED 66 can remain on during temperature measurement to assist in maintaining the position of temperature sensor 62. Device 50 may be configured to permit "scanning" of temperature sensor 62 to find the location of ABTT terminus 10. If device 50 includes this capability, once device 50 locates ABTT terminus 10, display 58 can be configured to display an appropriate indication, such as "ON TARGET." Once device 50 acquires a temperature measurement from ABTT terminus 10, the temperature result is presented on display 58, and the temperature result can remain on display 58 for a predetermined period, or can shut off with release of switch 64.

[0131] Other devices to capture temperature from ABTT terminus 10 can include an infrared (IR) array configured to

capture and analyze a face, and to automatically identify ABTT terminus 10 as well as provide the temperature at ABTT terminus 10. Such a temperature measurement device configured in accordance with an exemplary embodiment of the present disclosure is shown in FIGS. 6 and 7 and indicated generally at 100.

[0132] Device 100 is configured to include a handle 102 that is configured to support an IR imaging camera 104. Handle 102 can be configured to include a fingerprint recognition apparatus 106 as well as an operating switch 108. Device 100 can further be configured with an integral display (not shown), or can include a connector 110 that is configured to provide communication with an external electronic device, such as a laptop, cell phone, tablet, etc. (not shown). Device 100 can also include a transceiver, transmitter, or receiver to transmit information to an external electronic device. In an exemplary embodiment, infrared sensor array or IR imaging camera 104 can be configured to detect infrared light in the wavelength range of 8,200 to 11,200 nanometers.

[0133] Device 100 is operated by first grasping handle 102. If fingerprint recognition apparatus 106 is active, device 100 identifies the user to associate measured temperature data with a particular patient, and may also identify an authorized user. Once device 100 has provided the proper recognition, which may be indicated audibly, by display on a separate electronic device, or by illumination of an indicator (not shown) on device 100, acquisition of IR signals by camera 104 is available. Infrared light emitted from the ABTT carries brain diagnostic information within certain wavelengths, and IR imaging camera of the present disclosure is configured to preferably detect infrared light in the wavelength between 6,000 nanometers and 14,000 nanometers, and most preferably in the wavelength between 8,000 nanometers and 12,000 nanometers, and yet most preferably in the wavelength between 8,500 nanometers and 11,500 nanometers, and further yet most preferably between 8,200 nanometers and 11,200.

[0134] A user holds device 100 to aim at the area of the face that includes ABTT terminus 10, and presses operating switch 108. Because IR camera 104 has a relatively large field of view (FOV), camera 104 is able to image ABTT terminus 10 in addition to surrounding areas of the face. The image received by IR camera 104 may be transmitted to and processed within device 100 by a processor or controller (not shown), or the image may be transmitted as signals by a cable (not shown) attached to connector 110 to a separate electronic device, where the image data is processed to determine the temperature of ABTT terminus 10, as well as time varying temperature data. Additionally, the separate electronic device, which can be, for example, a laptop, tablet, cell phone, etc., can be configured to display the image, which can be useful for optimizing the position of device 100 as well as analyzing the image for thermal abnormalities, such as infection, poor blood flow, etc.

[0135] FIGS. 7A, 7B, and 7H show views of yet another device, indicated generally at 120, configured to assist in locating ABTT terminus 10 and then to measure the temperature of ABTT terminus 10 in accordance with an exemplary embodiment of the present disclosure. Device 120 includes a right sensor 120 and a left sensor 122 separated by an extendable connecting portion 126 to adjust for different nose sizes. Temperature measurement device 120 also includes a processor 128, a transmitter (or transceiver) 130, a non-transitory memory 132, a power source 134, such as a battery, and a

display 136. Display 136 is positioned on an opposite side of device 120 from right sensor 120 and left sensor 122. FIG. 7B shows device 120 with connecting portion 126 retracted to exemplarily adjust to a smaller nose size (or interpupillary distance). FIG. 7H shows simple display 136 displaying the temperature of right ABTT terminus 10 and of left ABTT terminus 10.

[0136] FIGS. 7C, 7D, and 7G show views of still yet another device, indicated generally at 170, configured to assist in locating ABTT terminus 10 and then to measure the temperature of ABTT terminus 10 in accordance with an exemplary embodiment of the present disclosure. Temperature measurement device 170 also includes processor 128 (which can be incorporated into any of the devices, apparatus, systems, etc., described herein), transmitter (or transceiver) 130, non-transitory memory 132, power source 134, such as a battery, a right display 176, and a left display 178. Right display 176 and left display 178 are positioned on an opposite side of device 170 from the sensors of device 170. FIG. 7D shows device 170 with connecting portion 126 retracted to exemplarily adjust to a smaller nose size (or interpupillary distance). FIG. 7G shows right display 176 and left display 178 on the back of device 170 capturing emissions from ABTT terminus 10, after device 170 has been adjusted and positioned to place sensor fields of view 190 on ABTT terminus 10. Right display 176 and left display 178 depict multiple pixels with stylized temperatures in the region of ABTT terminus 10, which includes a maximal temperature at ABTT terminus 10. It should be understood that a single display can be used in accordance to the principles of the present disclosure.

[0137] FIGS. 7E and 7F show views of an even further device, indicated generally at 180, configured to assist in locating ABTT terminus 10 and then to measure the temperature of ABTT terminus 10 in accordance with an exemplary embodiment of the present disclosure. Temperature measurement device 180 includes a transceiver 182 for communication with separate electronic device 184 (such as a cell phone), a right display 186, and a left array 188 positioned on an opposite side of device 180 from the sensors of device 180.

[0138] FIGS. 8-11 (excluding FIGS. 8A and 8B) show a temperature measurement device in accordance with an exemplary embodiment of the present disclosure, indicated generally at 150. Device 150 is configured with a device support 152, which rotatably supports a first device member 154 and a second device member 156. Device 150 is configured with at least one switch 158 to actuate a temperature measurement process by actuating temperature sensors (not shown) located within first device member 154 and second device member 156. Each device member 154 and 156 includes optics 160 such as lenses that are configured to gather a large FOV to make it easier to include ABTT terminus 10 as part of the FOV; i.e., when device 150 is held to a face, the diameter of optics 160 is such that when eyes 32 are centered on optics 160, optics 160 can also see ABTT terminus 10. Because first device member 154 and second device member 156 are configured to swivel or rotate, first device member 154 and second device member 156 can be adjusted to accommodate the variation in spacing of eyes 32 from each other. Device 150 may further include a connector 162 that is configured to permit connection of signals from device 150 to a separate electronic device (not shown), such as a laptop, tablet, cell phone, or the like. The separate electronic device can be configured to analyze the signals from device 150 and

to display the results of the analysis, including display of temperature maps or images acquired by temperature sensors located within device 150.

[0139] FIG. 8A shows a view of yet an even further device, indicated generally at 220, configured to locate at least one ABTT terminus 10 and then to measure the temperature of the at least one ABTT terminus 10 in accordance with an exemplary embodiment of the present disclosure. Temperature measurement device 220 includes left sensor 222 and right sensor 224, each rotatably mounted on a front portion of device 220. Device 220 further includes a first optical member 226 and a second optical member 228, each having an outer periphery or edge 230. First optical member 226 and second optical member 228 are configured such that an open space or volume 232 is formed between first optical member 226 and second optical member 228. Each of first sensor 222 and second sensor 224 extend or protrude past outer periphery or edge 230 into space or volume 232 so as to be positioned to view ABTT terminus 10 when device 220 is placed on the face of a subject. Each of right sensor 222 and left sensor 224 include a sensor surface 234 that is adapted to view ABTT terminus 10, allowing eyes of user to see an image, hologram, virtual reality, and/or augmented reality displayed by way of first optical member 226 and second optical member 228, thereby allowing capturing a signal from ABTT terminus 10 while viewing an image provided by first optical member 226 and second optical member 228.

[0140] FIG. 8B shows a view of a portion of still an even further device, indicated generally at 240, configured to locate at least one ABTT terminus and then to measure the temperature of the at least one ABTT terminus in accordance with an exemplary embodiment of the present disclosure. Device 240 includes a single sensor, such as right sensor 224. In addition, device 240 indicates two of the plurality of optional positions available for right sensor 224 by way of the rotational mounting of right sensor 224. It should be understood that a variety of mechanisms including sliding and rotating can be used to align right sensor 224 with ABTT terminus 10.

[0141] FIGS. 12-15 show another temperature measurement device in accordance with an exemplary embodiment of the present disclosure, indicated generally at 200. Device 200 is configured with a first device member 202 and a second device member 204, which are rotatably connected to each other. First device member 202 includes a first arm 206 and second device member 204 includes a second arm 208. Each of first arm 206 and second arm 208 include a temperature sensor 210 positioned at an end thereof. Each temperature sensor 210 is oriented to face the same direction. Temperature sensors 210 are oriented to be parallel to each other. In addition, the outermost surface of temperature sensors 210 that measure the thermal output of ABTT terminus 10 is approximately co-planar. Each temperature sensor 210 is a spaced distance away from respective first device member 202 and second device member 204 to permit each temperature sensor 210 to be positioned adjacent to an ABTT terminus 10 without interference of first device member 202 and second device member 204 with an associated face. Device 200 is configured with at least one switch 212 to actuate a temperature measurement process by actuating temperature sensors 210. Because first device member 202 and second device member 204 are configured to swivel or rotate with respect to each other, first device member 202 and second device member 204 can be adjusted to accommodate the variation in spacing

of eyes 32 from each other. Device 200 may further include a connector 214 that is configured to permit connection of signals from device 200 that originate from temperature sensors 210 to a separate electronic device (not shown), such as a laptop, tablet, cell phone, or the like. The separate electronic device can be configured to analyze the signals from device 200 and to display the results of the analysis.

[0142] FIGS. 16-18 show another temperature measurement device in accordance with an exemplary embodiment of the present disclosure, indicated generally at 250. Device 250 is configured with a first device member 252 and a second device member 254, both of which are rotatably supported on a device support 256. As with devices 150 and 200, first device member 252 and second device member 254 are configured to swivel or rotate with respect to each other, such that first device member 252 and second device member 254 can be adjusted to accommodate the variation in spacing of eyes 32 from each other. First device member 252 and second device member 254 are each configured to support a temperature sensor 258. In the exemplary embodiment of FIGS. 16-18, first device member 252 and second device member 254 are configured to move independently with respect to each other. In another embodiment, first device member 252 and second device member 254 can be configured to move each other through a frictional or gear arrangement. In yet another embodiment, first device member 252 and second device member can be configured to slide laterally or transversely to change the spacing between first device member 252 and second device member 254. Device 250 is further configured to include a connector 260 that is configured to permit connection of signals from device 250 that originate from temperature sensors 258 to a separate electronic device (not shown), such as a laptop, tablet, cell phone, or the like. The separate electronic device can be configured to analyze the signals from device 250 and to display the results of the analysis.

[0143] IR camera imaging camera 104, shown positioned on a handle in FIGS. 6 and 7, can be mounted in other ways, such as are shown in FIGS. 19-26. FIGS. 19 and 20 show camera 104 positioned or located on a telescoping support 270 suitable to be positioned on a desk or table. FIGS. 21 and 22 show camera 104 positioned or located on a swing arm support 272. FIGS. 23 and 24 show camera 104 positioned or located on a goose neck support 274. FIGS. 25 and 26 show camera 104 positioned or located on a wall mount support 276.

[0144] Other devices may be collocated with camera 104. For example, FIGS. 27-30 show a configuration of camera 104 that includes a transceiver, transmitter, or receiver 278 configured to communicate with a separate electronic device, e.g., a laptop, cell phone, tablet, non-transitory storage medium, etc.

[0145] FIGS. 30A and 30B show device 170 of FIGS. 7C and 7D positioned on swing arm support 272 for adjustment to different heights of subjects being measured. In the embodiment of FIG. 30A, a digital camera 192 is positioned above right sensor array 172 and left sensor array 174, and said camera is adapted to superimpose a digital image on top of an infrared image to allow identification of certain anatomic landmarks in relation to the amount of thermal emission of said anatomic landmarks. FIG. 30B is a side view of the elements shown in FIG. 30A and shows shortening.

[0146] FIGS. 30C and 30D show a screw-based mounting mechanism 194 for device 170. FIG. 30D shows device 170

positioned on telescoping support 270 for adjustment to different height of subjects being measured. Device 170 is configured similar to the arrangement of FIGS. 30A and 30B and includes digital camera 192 positioned above right sensor array 172 and left sensor array 174. Although infrared detector was shown as a dual detector or dual sensor array, right and left sensor arrays, it should be understood that one single array adapted to detect signal from both the right ABTT and the left ABTT can be used, and are shown in FIG. 30E as one single sensor array 173. It should also be understood that a single sensor array can be used in any embodiment of the present invention.

[0147] FIGS. 31-33 show a system configured to locate ABTT terminus 10 and then to measure the temperature of ABTT terminus 10, in accordance with an exemplary embodiment of the present disclosure, indicated generally at 300. System 300 is configured to include a desk, table, or platform 302 that is further configured to support element of system 300. System 300 is further configured to include a support system 304 configured to support a movable IR camera 306. Support system 304 is configured to allow camera 306 to be movable or adjustable to a plurality of vertical positions to be able to locate at least one ABTT terminus 10. In an exemplary embodiment, camera 306 is moved manually. In another exemplary embodiment, camera 306 is moved by way of a controller, described in more detail herein. In a further exemplary embodiment, camera 306 is automatically moveable to locate a face and at least one ABTT terminus 10.

[0148] System 300 is further configured to include a control device 308 that can be configured to include a keypad, microphone, USB or other port, card scanner, or other device to provide various control functions for system 300. Such control functions can include movement of IR camera 306 along support system 304 to align IR camera 306 with a face 310. IR camera 306 can be configured to include a connector (not shown), a transceiver 312, or both. Similarly, control device 308 can be configured to include a connector (not shown), a transceiver 314, or both. Thus, control device 308 can communicate with IR camera 306 by way of a cable (not shown) or by way of transceivers 312 and 314. System 300 can further be configured to include a pressure or presence detection device 316 that includes a pressure or presence sensor and is configured to communicate with control device 308 either through a cable (not shown) or wirelessly.

[0149] It should be understood that IR camera 306 includes a FOV 318 of a certain angle. In an exemplary embodiment, the configuration and position of IR camera 306 is such that FOV 318 is sufficiently large to include most or all of a subject or patient's face 310 when a subject 320 is standing at a location of pressure or presence detection device 316. It should be understood that within FOV 318 is a smaller two-dimensional area 322 that corresponds to the area of ABTT terminus 10 and an area directly adjacent or next to ABTT terminus 10.

[0150] To operate system 300, subject 320 stands on pressure or presence detection device 316, which initiates or actuates system 300. Pressure or presence detection device 316 can immediately provide the weight of subject 320. In an exemplary embodiment, subject 320 can begin a temperature measurement operation by pressing a key on control device 308. Alternatively, the presence of subject 320 on pressure detection device 316 can initiate a temperature measurement operation. As yet another alternative, a separate electronic device 324, such as a cell phone, laptop, tablet, etc., can be

configured to communicate with system 300 and to initiate system 300 operation as well as control the functions of system 300.

[0151] In an exemplary embodiment, subject 320 either manually moves IR camera 306 to be at an eye level, or uses controls on control device 308 to position IR camera 306 vertically along support system 304. In another exemplary embodiment, IR camera 306 moves along support system 304, scanning for a hot spot represented by ABTT terminus 10. In this latter embodiment, once IR camera 306 identifies the hot spot represented by ABTT terminus 10, IR camera 306 positions itself to acquire temperature signals from ABTT terminus 10. It should be noted that the movement of IR camera 306 also provides system 300 with the ability to measure the height of subject 320, since IR camera 306 can determine the location of the top of a head of subject 320 through its thermal imaging capability. Alternatively, once IR camera 306 has located ABTT terminus 10, system 300 can estimate the height of subject 320 given that the average distance from ABTT terminus 10 to the top of a typical person's head is a previously measured distance.

[0152] Once IR camera 306 is positioned to measure the temperature of ABTT terminus 10, acquisition and analysis of temperature data begins, which may be accomplished in control device 308 or in separate electronic device 324. The data acquisition process can be configured to include a plurality of time intervals, depending on the type of data analysis required. For simple temperature measurements, the length of data acquisition is typically seconds, e.g., 10 to 20 seconds. For complex measurements, the length of data acquisition can be minutes. Some data acquisition intervals may be very lengthy and it can be beneficial to provide a chair for subject 320.

[0153] FIGS. 33A and 33B show views of another system, indicated generally at 330, configured to locate ABTT terminus 10 and then to measure the temperature of ABTT terminus 10, in accordance with an exemplary embodiment of the present disclosure. ABTT temperature measurement system includes right sensor array 172, left sensor array 174, a sliding mechanism 332 to change the position of right sensor array 172 and left sensor array 174, and a combination keypad and card reader 334 having a card slot 336. In this embodiment there is no display, such as might be used for advertisements, and measurement is done by inserting an ID card in card slot 336 or inserting a credit card in card slot 336 for payment. As shown in FIG. 33B, keypad and card reader 334 includes a second slot 338 for connecting with electronic device 184 being operatively coupled with system 330 during measurement, in which electronic device 184, for example a cell phone, when placed in electronic device slot 338 provides height information to system 330 allowing thereby automatic height adjustment by sliding mechanism 332. Keypad and card reader 334 can include a reader for a credit card in the event a user is purchasing measurement, an identification card, and the like.

[0154] Support system 304 can be configured in a variety of arrangements. FIGS. 34 and 35 show an exemplary support system 304a that includes an "H" configuration, including two vertically extending poles 326 and a cross bar 328. IR camera 306 is configured to move left and right along cross bar 328, and cross bar 328 is configured to move vertically along poles 326, with both movements permitting movement of IR camera 306 to align with a subject or patient's face. FIGS. 36 and 37 show another exemplary support system

**304b** that includes a single pole **326** configured to permit movement of IR camera **306** vertically along pole **326**. To achieve left-right or horizontal positioning, a patient or subject would move left or right.

[0155] FIGS. **38-42** show another ABTT temperature measurement system in accordance with an exemplary embodiment of the present disclosure, indicated generally at **350**. System **350** is similar to system **300** in many respects, but system **350** further includes a mirror **352**.

[0156] FIGS. **43-48** show another ABTT temperature measurement system in accordance with an exemplary embodiment of the present disclosure, indicated generally at **360**. System **360** is similar to systems **300** and **350** in many respects, but system **360** further includes a display **362** configured to present the output of IR camera **306** to subject **320**. Display **362** is transparent to IR energy, so camera **306** receives IR energy transmitted through display **362**.

[0157] FIGS. **49-55** show another ABTT temperature measurement system in accordance with an exemplary embodiment of the present disclosure, indicated generally at **370**. System **370** is similar to system **360** in many respects, but system **370** further includes a digital camera **372** configured to capture an image of face **310** at visible optical wavelengths and to present face **310** on display **362** to aid in aligning IR camera **306**.

[0158] FIGS. **56-62** show another ABTT temperature measurement system in accordance with an exemplary embodiment of the present disclosure, indicated generally at **380**. System **380** is similar to systems **360** and **370** in many respects, but system **380** further includes a display device **382** positioned adjacent to IR camera **306**. Display device **382** can be configured to include a digital camera, the output of which is presented on display device **382** to aid in aligning IR camera **306** with respect to face **310**.

[0159] FIGS. **63-69** show another ABTT temperature measurement system in accordance with an exemplary embodiment of the present disclosure, indicated generally at **390**. System **390** includes selective features from systems **370** and **380**. Display device **382** is configured to present visual data provided by digital camera **372** to aid in aligning IR camera **306** with respect to face **310**.

[0160] FIG. **70** shows another system configured to locate ABTT terminus **10** and then to measure the temperature of ABTT terminus **10**, in accordance with an exemplary embodiment of the present disclosure, indicated generally at **400**. System **400** is configured to include a support system **402** configured to support a movable IR camera **404**. Support system **402** is configured to allow IR camera **404** to be movable or adjustable to a plurality of vertical positions to be able to locate at least one ABTT terminus **10**. In an exemplary embodiment, camera **404** is moved manually. In another exemplary embodiment, camera **404** is moved by way of a controller. In a further exemplary embodiment, camera **404** is automatically moveable to locate a face **406** and at least one ABTT terminus **10**.

[0161] FIGS. **70A** and **70B** show views of yet another system, indicated generally at **420**, configured to locate ABTT terminus **10** and then to measure the temperature of the ABTT terminus **10**, in accordance with an exemplary embodiment of the present disclosure. System **420** includes an infrared sensor array **422**, which may include a thermopile array, positioned above a display **424** and being operatively coupled with display **424**. Display **424** can be configured to display an advertisement during measurement of emissions from ABTT

terminus **10**, and measurement results can be configured to appear on display **424** at random times during the advertisement. FIG. **70B** shows view of a portion of system **420** during measurement of a subject, with sensor array **422** capturing thermal signals from ABTT terminus **10** of the subject.

[0162] FIGS. **70C** and **70D** show views of still yet another system, indicated generally at **430**, configured to locate ABTT terminus **10** and then to measure the temperature of ABTT terminus **10**, in accordance with an exemplary embodiment of the present disclosure. ABTT temperature measurement system **430** includes thermal sensors **432** positioned behind a screen **434**, thermal sensors **432** include at least one of infrared sensors and a thermal imaging device, and screen **434** being preferably an LED display to facilitate calculating thermal energy generated by screen **434**, since LED's have a rather stable temperature, and the temperature of LED screen **434** can be used to adjust or correct the temperature measured by sensors **432** to determine the temperature of ABTT terminus **10**. Screen **434** can also be transparent to IR energy, so infrared sensors **432** receive IR energy transmitted through screen **434**. System **430** is configured to measure thermal signals from ABTT terminus **10** while an image **436**, such as an advertisement, is being shown on screen **434**, and the subject must look at screen **434** to be measured. In addition, the measurement results are shown on screen **434**. FIG. **70D** shows system **430** during measurement of the subject, with sensor array **432** capturing thermal signals from ABTT terminus **10** of the subject.

[0163] FIGS. **70E** and **70F** show views of an even further system, indicated generally at **450**, configured to locate ABTT terminus **10** and then to measure the temperature of ABTT terminus **10**, in accordance with an exemplary embodiment of the present disclosure. ABTT temperature measurement system **450** includes a digital camera **452**, an infrared sensor array **454**, and a screen **456** showing advertisement **458** or other information while measurement of emissions from ABTT terminus **10** is conducted. FIG. **70F** shows system **450** during measurement of the subject, with sensor array capturing thermal signal from ABTT of a subject. Digital camera **452** captures an image of ABTT terminus **10** and eyes **32**, and uses this image information to align infrared sensor array **454** with ABTT terminus **10**. Then the digital image is superimposed on the displayed thermal image.

[0164] FIGS. **70G** and **70H** show views of an even further system, indicated generally at **460**, configured to locate ABTT terminus **10** and then to measure the temperature of ABTT terminus **10**, in accordance with an exemplary embodiment of the present disclosure. ABTT temperature measurement system **460** includes a thermal image camera **462** and a screen **464** showing advertisement **466** or other information while measurements are being taken of thermal emissions of ABTT terminus **10**. FIG. **70H** shows a view of system **460** during measurement of the subject, with sensor array **462** capturing thermal signals from ABTT terminus **10** of the subject.

[0165] FIGS. **70I-K** show views of an even further system, indicated generally at **470**, configured to locate ABTT terminus **10** and then to measure the temperature of ABTT terminus **10**, in accordance with an exemplary embodiment of the present disclosure. ABTT temperature measurement system **470** includes digital camera **452**, infrared sensor array **454**, and a clamp mechanism **472** being configured to secure an electronic device **474**, electronic device **474** including a dis-

play 476 and showing on its display 476 an advertisement 478 or other information while measurement is being taken. FIG. 70J shows details of clamp mechanism 472 for securing electronic device 474, such as a cell phone, tablet, computer, and the like. FIG. 70I shows a view of system 470 during measurement of the subject, with sensor array 454 capturing thermal signals from ABTT terminus 10 of the subject. Digital camera 452 captures an image of ABTT terminus 10 and eyes 32, and uses this image information to align infrared sensor 454 with ABTT terminus 10. The digital image is then superimposed on the thermal image.

[0166] FIGS. 70L-70M show views of an even further system, indicated generally at 540, configured to locate ABTT terminus 10 and then to measure the temperature of ABTT terminus 10, in accordance with an exemplary embodiment of the present disclosure. System 540, and other systems of the present disclosure, can alternatively be described as being measuring stations. ABTT temperature measurement system 540 includes sensor device 542, which includes a rod 544 having a contact sensor 546 at its free end, such as a thermistor, a keypad 548, and a display 550 adjacent to keypad 548, display 550 reporting the value measured by sensor device 542. Display 550 is operatively coupled with electronics of sensor device 542, display 550 displaying an advertisement after the measurement is done, and display 550 displaying simultaneously the measurement results. Pen-like sensor device 542 is connected to sliding mechanism 332 of system 540 for alignment of sensor 546 with ABTT terminus 10 of people with different height. In this embodiment, the results are calculated and reported after the measurement is done, and there is no movable display, as it was shown in FIGS. 70A to 70H. The measuring device, illustrated as a pen-like sensor device and a dual sensor device in FIGS. 70L to 70N have been described in co-pending U.S. patent application Ser. No. 15/\_\_\_\_\_, filed Mar. 10, 2016, incorporated by reference herein in its entirety. FIG. 70M shows one single sensor device 542, which includes a mechanical connector (not shown) for connecting with sliding mechanism 332 of system 540 and includes a rotating mechanism for alignment of contact sensor 546 with ABTT terminus 10.

[0167] FIG. 70N shows a dual sensor device, indicated generally at 560, in accordance with an exemplary embodiment of the present disclosure. Device 560 includes a connector (not shown) for connecting with sliding mechanism 332 of system 540. Device 560 includes a right arm 562 and a left arm 564. Right arm 562 includes a right sensor 566 and left arm 564 includes a left sensor 568.

[0168] FIG. 70O shows a sensor device, indicated generally at 580, in accordance with an exemplary embodiment of the present disclosure. Device 580 includes a sensor body 582, and a sensor rod 584 connected to sensor body 582 by a retractable cable or wire 586. Sensor body 582 is configured to mount on and interface with sliding mechanism 332 of system 540. Device 580 further includes sensor 590 positioned on sensor rod 584 at a distal end thereof and a cover 588 to protect sensor 590 to avoid cross-contamination during measurement.

[0169] FIG. 70P shows a sensor device, indicated generally at 600, in accordance with an exemplary embodiment of the present disclosure. Device 600 includes dual sensors 602 and a sensor rod 604 on which sensors 602 are positioned. Sensor rod 604 includes a connector 606 for mating with a connector or jack 608 of a retractable cable or wire 610 of, for example,

system 540. Sensor device 600 further includes a cover 612 for sensors 602 to avoid cross-contamination during measurement.

[0170] FIG. 70Q shows system 540 with the addition of a display 552 connected to sliding mechanism 332, with display 553 the temperature of right ABTT terminus 10 and left ABTT terminus 10.

[0171] Clinical experiments by Applicant, who is a medical doctor, showed that measuring right ABTT terminus 10 and left ABTT terminus, preferably simultaneously, provides key clinical information on the risk of several diseases and the diagnosis of several diseases. The measurements can include the absolute number (for instance, 36.6 degrees Celsius on the right and 36.0 Celsius on the left) and differences between the left and right side, or variations of temperature with time. The following graphs, which plot temperature vs. time for right ABTT terminus 10 ("R") and left ABTT terminus 10 ("L"), describe hitherto unrecognized characteristics of diseases and conditions based on analysis of the output of ABTT terminus 10.

[0172] FIG. 72 shows right ABTT terminus 10 having a higher temperature than left ABTT terminus 10, indicating risk of aneurysm rupture on the right side.

[0173] FIG. 73 shows normal temperature in right ABTT terminus 10 and higher temperature in left ABTT terminus 10 indicating risk of brain cancer in the left side.

[0174] FIG. 74 shows an oscillatory pattern with higher frequency on left ABTT terminus 10 and lower frequency on right ABTT terminus 10 indicating risk of seizures on the left side.

[0175] FIG. 75 shows an oscillatory pattern with frequency lower than normal in both sides, but higher frequency in right ABTT terminus 10, indicating progression of infection on the left side of the brain or nervous system.

[0176] FIG. 76 shows a higher velocity of temperature change in right ABTT terminus 10 as compared to the lower ABTT indicating risk of abscess in the right side.

[0177] FIG. 77 shows an oscillatory pattern with lower frequency on both, right ABTT terminus 10 and left ABTT terminus 10, indicating Alzheimer's disease or spread of Alzheimer's disease beyond the hippocampus.

[0178] FIG. 78 shows a display indicating numerical absolute value with lower temperature in right ABTT terminus 10 (36.0 degrees Celsius) and normal temperature in left ABTT terminus 10 (36.7 degrees Celsius) indicating risk of stroke in the right side.

[0179] System 400 is further configured to include a control device 408 that can be configured to include a keypad, microphone, USB or other port, card scanner, or other device to provide various control functions for system 400. Such control functions can include movement of IR camera 404 along support system 402 to align IR camera 404 with face 406. IR camera 404 can be configured to include a connector (not shown), a transceiver (not shown), or both. Similarly, control device 408 can be configured to include a connector (not shown), a transceiver (not shown), or both. Thus, control device 408 can communicate with IR camera 404 by way of a cable (not shown) or wirelessly. System 400 can further be configured to include pressure or presence detection device 316 that includes a pressure or presence sensor and is configured to communicate with control device 408 either through a cable (not shown) or wirelessly.

[0180] It should be understood that IR camera 404 includes a FOV 410 of a certain angle. In an exemplary embodiment,

the configuration and position of IR camera 404 is such that FOV 410 is sufficiently large to include most or all of face 406 when a subject 412 is standing at a location of pressure or presence detection device 316. It should be understood that within FOV 410 is a smaller two-dimensional area 414 that corresponds to the area of ABTT terminus 10 and an area directly adjacent or next to ABTT terminus 10.

[0181] To operate system 400, subject 412 stands on pressure or presence detection device 316, which initiates or actuates system 400. Pressure or presence detection device 316 can immediately provide the weight of subject 412. In an exemplary embodiment, subject 412 can begin a temperature measurement operation by pressing a key on control device 408. Alternatively, the presence of subject 412 on pressure detection device 316 can initiate a temperature measurement operation. As yet another alternative, a separate electronic device (not shown), such as a cell phone, laptop, tablet, etc., can be configured to communicate with system 400 and to initiate system 400 operation as well as control the functions of system 400.

[0182] In an exemplary embodiment, subject 412 either manually moves IR camera 404 to aim toward an eye of subject 412, or uses controls on control device 408 to position IR camera 404 vertically along support system 402. In another exemplary embodiment, IR camera 404 moves along support system 402, scanning for the hot spot represented by ABTT terminus 10. In this latter embodiment, once IR camera 404 identifies the hot spot represented by ABTT terminus 10, IR camera 404 positions itself to acquire temperature signals from ABTT terminus 10. It should be noted that the movement of IR camera 404 also provides system 400 with the ability to measure the height of subject 412, since IR camera 404 can determine the location of the top of a head of subject 412 through its thermal imaging capability. Alternatively, once IR camera 404 has located ABTT terminus 10, system 400 can estimate the height of subject 412 given that the average distance from ABTT terminus 10 to the top of a typical person's head is a previously measured distance.

[0183] Once IR camera 404 is positioned to measure the temperature of ABTT terminus 10, acquisition and analysis of temperature data begins, which may be accomplished in control device 408 or in separate electronic device (not shown). The data acquisition process can be configured to include a plurality of time intervals, depending on the type of data analysis required. For simple temperature measurements, the length of data acquisition is typically seconds, e.g., 10 to 20 seconds. For complex measurements, the length of data acquisition can be minutes. Some data acquisition intervals may be very lengthy and it can be beneficial to provide a chair for subject 412.

[0184] FIG. 71 shows an ABTT acquisition process in accordance with an exemplary embodiment of the present disclosure, indicated generally at 500. The function of process 500 is to drive an IR camera, such as IR camera 306, to a location where the temperature output of ABTT terminus 10 can be measured. Process 500 begins with a start process 502, during which various elements of an ABTT temperature measurement system are powered and initialized. Once the ABTT temperature measurement system is initialized, control passes from start process 502 to a first direction movement process 504.

[0185] In first direction movement process 504, the IR camera is moved vertically along a support system. While the IR camera is moving, it is acquiring IR imagery. In an exemplary

embodiment, the data from the IR camera is being analyzed, for example at an analyze data process 506, as the data is acquired. In another exemplary embodiment, the data is analyzed after the IR camera reaches a first limit of travel. If the data is analyzed in near real time, as the data is acquired, control moves to an ABTT terminus located decision process 508 once a location of ABTT terminus 10 has been identified. Otherwise, the IR camera is permitted to reach the first limit before control is passed to ABTT terminus located decision process 508.

[0186] At ABTT terminus located decision process 508, a decision as to whether ABTT terminus 10 has been located is made. Such a decision may be made if a predetermined temperature of a face is identified, such as a temperature in a range of 97.5 to 106 degrees Fahrenheit. In certain circumstances, skin surrounding ABTT terminus 10 may be hotter than ABTT terminus 10. The ABTT temperature measurement systems of the present disclosure are able to handle this situation by recognizing that all temperatures surrounding ABTT terminus 10 are hotter than ABTT terminus 10, thus recognizing that ABTT terminus 10 is cooler than skin surrounding ABTT terminus 10. In a very rare circumstance, the temperature of surrounding skin is approximately the same temperature of ABTT terminus 10, which may require additional measures to cool the surrounding skin to gain valid temperature measurements. If ABTT terminus 10 can be identified, control passes to a move to an ABTT terminus location process 510. If ABTT terminus 10 cannot be identified, control passes to a second direction movement process 518.

[0187] In move to ABTT terminus location process 510, the IR camera is driven to the height or location at which ABTT terminus 10 was identified. Once the IR camera reaches the determined location, control passes from ABTT terminus location process 510 to an acquire data process 512.

[0188] In acquire data process 512, temperature data from ABTT terminus 10 is acquired for a predetermined period. Such data acquisition can be for seconds to many minutes. A typical range of data acquisition for temperature readings only is approximately 10 to 20 seconds. For more detailed data acquisition to diagnose medical conditions, data acquisition can be from 30 seconds to 20 minutes or even more. Once the predetermined period for data acquisition has been reached, control passes from acquire data process 512 to an analyze data process 514.

[0189] The data received in acquire data process 512 is analyzed in analyze data process 514. Once analysis is complete, control moves from analyze data process 514 to a transmit or display data process 516, where the analyzed data is transmitted to an electronic device, such as a laptop, tablet, cell phone, etc., or the data is displayed on a system display, or both. Control then passes to an end process 526, which can place all hardware into a standby mode or an off mode after a predetermined period to permit review of the analyzed data.

[0190] Returning to second direction movement process 518, the IR camera is moved vertically along the support system in a second direction that is opposite to the first direction. While the IR camera is moving, it is acquiring IR imagery. In an exemplary embodiment, the data from the IR camera is being analyzed, for example at an analyze data process 520, as the data is acquired. In another exemplary embodiment, the data is analyzed after the IR camera reaches a second limit of travel. If the data is analyzed in near real time, as the data is acquired, control moves to an ABTT terminus

located decision process 522 once a location of ABTT terminus 10 has been identified. Otherwise, the IR camera is permitted to reach the first limit before control is passed to ABTT terminus located decision process 522.

[0191] At ABTT terminus located decision process 522, a decision as to whether ABTT terminus 10 has been located is made. Such a decision may be made if a predetermined temperature of a face is identified, such as a temperature in a range of 97.5 to 106 degrees Fahrenheit. In certain circumstances, skin surrounding ABTT terminus 10 may be hotter than ABTT terminus 10. The ABTT temperature measurement systems of the present disclosure are able to handle this situation by recognizing that all temperatures surrounding ABTT terminus 10 are hotter than ABTT terminus 10, thus recognizing that ABTT terminus 10 is cooler than skin surrounding ABTT terminus 10. In a very rare circumstance, the temperature of surrounding skin is approximately the same temperature of ABTT terminus 10, which may require additional measures to cool the surrounding skin to gain valid temperature measurements. If ABTT terminus 10 can be identified, control passes to a move to ABTT terminus location process 510, which operates as previously described herein. If ABTT terminus 10 cannot be identified, control passes to a return error process 524.

[0192] In return error process 524, a notification is provided to the subject, patient, or other individual that ABTT terminus 10 was not located. Control then passes from return error process 524 to end process 526, which functions as previously described.

[0193] While some embodiments herein describe thermal imaging such that an entirety of a face is acquired, it should be apparent that full face imaging is not required to locate and identify a horn-shaped region between the eye and the nose where ABTT terminus 10 is located. Thus, in some embodiments the thermal imaging camera may only need a field of view sufficient to identify the unique location on the face where ABTT terminus 10 is located rather than an entire face.

[0194] While various embodiments of the disclosure have been shown and described, it is understood that these embodiments are not limited thereto. The embodiments can be changed, modified, and further applied by those skilled in the art. Therefore, these embodiments are not limited to the detail shown and described previously, but also include all such changes and modifications. Any part of any embodiment can be used in combination to create a single embodiment, and any part of any embodiment can be used as a replacement or addition to another embodiment, and all resultant embodiments are within the scope of the present disclosure.

I claim:

1. A device for measuring a temperature of an Abreu brain thermal tunnel (ABTT), the device comprising:

- a handle;
- a mirror including a mirrored surface supported by the handle;
- an arm extending from one of the handle and the mirror in a direction that is away from the mirror;
- a temperature sensor sized and dimensioned to measure the temperature of an ABTT terminus, the temperature sensor positioned on an end of the arm, the temperature sensor configured to provide a temperature measurement; and
- a display configured to receive and display the temperature measurement.

2. The device of claim 1, further including a light source positioned on the arm.

3. A device for locating an Abreu brain thermal tunnel (ABTT) and measuring thermal data from the ABTT, the device comprising:

- a thermal imaging camera configured to acquire a thermal image of a human face and to transmit the thermal image;
- a processor configured to receive the transmitted thermal image, to analyze the thermal image to determine a location of an ABTT terminus, and to transmit the result of the analysis of the thermal image; and
- a display configured to receive the results of the analysis of the thermal image and to display the results of the analysis.

4. The device of claim 3, wherein the thermal imaging camera is configured to automatically move to locate the human face.

5. The device of claim 3, wherein the display is a display of an electronic device that is separate from the device.

6. The device of claim 5, wherein the separate electronic device is a cell phone and the transmission from the processor to the cell phone is wireless transmission.

7. The device of claim 3, wherein the thermal imaging camera is configured to measure light in the range 8,000 nanometers to 12,000 nanometers.

8. The device of claim 3, further including a fingerprint identification device configured to detect a fingerprint and to use the results of the detection to actuate the device.

9. The device of claim 3, wherein the thermal imaging camera is positioned on a flexible support mount.

10. The device of claim 3, wherein the thermal imaging camera is positioned on a swing arm mount.

11. The device of claim 3, further including at least one of a pressure sensor and a presence sensor, and actuation of the at least one pressure sensor and presence sensor causes the device to be actuated.

12. The device of claim 3, wherein the display is positioned adjacent to the thermal imaging camera.

13. The device of claim 3, wherein the thermal imaging camera is configured to acquire a thermal image of an entirety of the human face.

14. The device of claim 3, further including a camera configured to acquire an image of the human face at visible wavelengths and to present the acquired image on the display.

15. The device of claim 3, wherein the thermal imaging camera comprises an array of thermopiles.

16. The device of claim 3, wherein a mirror is positioned between the thermal imaging camera and the human face.

17. The device of claim 3, wherein a display is positioned between the thermal imaging camera and the human face.

18. The device of claim 3, wherein the thermal image is taken of an area between the eyebrow and the eye.

19. The device of claim 3, wherein a digital image is superimposed on the thermal image.

20. A device for measuring a temperature of two Abreu brain thermal tunnels (ABTT's), the device comprising:

- a first thermal sensor positioned on a first member and sized and dimensioned to measure a thermal output of a first ABTT terminus, the first thermal sensor oriented in a first direction;
- a second thermal sensor supported by a second member and sized and dimensioned to measure a thermal output

of a second ABTT terminus, the second thermal sensor oriented in a second direction; and

the first member is movable to vary the distance between the first thermal sensor and the second thermal sensor.

**21.** The device of claim **20**, wherein the second member is rotatable.

**22.** The device of claim **21**, wherein the first member is rotatable and the first and second member are individually rotatable with respect to each other.

**23.** The device of claim **21**, wherein the first thermal sensor and the second thermal sensor are parallel and approximately co-planar.

**24.** The device of claim **21**, wherein the first direction and the second direction are parallel directions.

**25.** The device of claim **21**, further including at least one optic lens.

**26.** The device of claim **20**, wherein the sensors are contact sensors.

**27.** The device of claim **20**, wherein the sensors are non-contact sensors.

**28.** A system for measuring emissions of at least one Abreu brain thermal tunnel terminus, the system comprising:

a sensor configured to receive the emissions and to transmit signals representative of the emissions during an interval of time;

a display; and

a processor configured to receive the signal, to analyze the signal, and to provide an output representative of at least one of the signal and the analysis of the signal to the display, the processor further configured to provide an output that includes an advertisement during the interval of time and during a time to receive the signal and to analyze the signal.

**29.** The system of claim **28**, wherein the display simultaneously presents data during the advertisement.

**30.** The system of claim **29**, wherein the data is presented at random times during the advertisement.

**31.** The system of claim **28**, wherein the sensor is a sensor array.

**32.** The system of claim **28**, wherein the sensor is a thermal imaging sensor.

**33.** The system of claim **28**, wherein the sensor is a contact sensor.

**34.** The system of claim **28**, wherein the sensor is a non-contact sensor.

**35.** A method of acquiring, analyzing, and displaying data acquired from at least one Abreu brain thermal tunnel terminus, the method comprising:

receiving emissions from the at least one Abreu brain thermal tunnel terminus during an interval of time;

transmitting signals representative of the emissions to a processor;

analyzing the transmitted signals and presenting the results on a display; and

displaying an advertisement during the interval of time.

**36.** The method of claim **35**, wherein the advertisement is displayed during a time required to analyze the transmitted signals.

**37.** The method of claim **35**, wherein data is displayed while the advertisement is displayed.

**38.** The method of claim **35**, wherein data is displayed at random times during the advertisement.

\* \* \* \* \*

专利名称(译)	用于测量ABTT末端温度的装置，设备，系统和方法		
公开(公告)号	<a href="#">US20160262629A1</a>	公开(公告)日	2016-09-15
申请号	US15/066779	申请日	2016-03-10
申请(专利权)人(译)	GEELUX HOLDINGS , LTD.		
当前申请(专利权)人(译)	GEELUX HOLDINGS , LTD.		
[标]发明人	ABREU MARCIO MARC		
发明人	ABREU, MARCIO MARC		
IPC分类号	A61B5/01 A61B5/1172 A61B5/00		
CPC分类号	A61B5/01 A61B5/0079 A61B5/0042 A61B5/7425 A61B5/0008 A61B5/1172 A61B2503/12 A61B5/0013 A61B2562/16 A61B2562/0247 A61B2562/08 A61B2562/0271 A61B2090/065 A61B5/6898 A61B5/4064		
优先权	62/131131 2015-03-10 US		
外部链接	<a href="#">Espacenet</a> <a href="#">USPTO</a>		

摘要(译)

设备，系统，装置，机制和方法用来定位ABTT末端，然后测量ABTT末端的温度。

